

**STATE OF NORTH CAROLINA
DEPARTMENT OF TRANSPORTATION**

TIP NO. B-4028	SHEET NO. SIGN-1
APPROVED: <i>[Signature]</i>	
DATE: 4/26/12	
SEAL	



**SIGNING PLAN
BLADEN COUNTY**

**LOCATION: BRIDGE NOS. 12, 18, AND 42 OVER CAPE FEAR
RIVER ABD OVERFLOW ON NC 11**

CONTRACT: C202878 T.I.P.: B-4028

SUMMARY OF QUANTITIES

ITEM NO.		ITEM DESCRIPTION	QUANTITY	UNIT
DESC. NO.	SECT. NO.			
4072000000	903	SUPPORTS, 3 LB STEEL U-CHANNEL	200	L.F.
4096000000	904	SIGN ERECTION, TYPE D	5	EA.
4102000000	904	SIGN ERECTION, TYPE E	1	EA.
4108000000	904	SIGN ERECTION, TYPE F	1	EA.
4116100000	904	SIGN ERECTION, RELOCATE SIGN TYPE D	1	EA.
4116100000	904	SIGN ERECTION, RELOCATE SIGN TYPE E	2	EA.
4155000000	907	DISPOSAL OF SIGN SYSTEM, U-CHANNEL	18	EA.
4192000000	907	DISPOSAL OF SUPPORT, U-CHANNEL	2	EA.

GENERAL NOTES

- . SIGNS FURNISHED BY STATE
- . ALL TYPE 'D' SIGNS SHALL BE MOUNTED ON TWO U-CHANNEL POSTS UNLESS OTHERWISE INDICATED ON THE PLANS.
- . IF REMOVAL OR RELOCATION OF SIGNS ON PRIVATE STREET (NON-STATE MAINTAINED) IS REQUIRED DUE TO CONSTRUCTION, THE CONTRACTOR SHALL INFORM THE ENGINEER. THE WORK WILL BE COMPLETED BY OTHERS.
- . ALL EXISTING SIGNS ON "U" CHANNEL POST WITHIN THE PROJECT LIMITS SHALL BE REMOVED AND DISPOSED OF UNLESS OTHERWISE NOTED ON PLANS.
- . WHEN EXISTING SIGNS ARE REMOVED AND INSTALLED ON NEW SUPPORTS, THE RE-ERECTION SHALL IMMEDIATELY FOLLOW THE REMOVAL.
- . THE BACKGROUND FOR TYPE E & F SIGNS SHALL BE TYPE C REFLECTIVE SHEETING.
- . SEE ROADWAY PLANS FOR GUARD/GUIDE RAIL DETAILS.

ROADWAY STANDARD DRAWING

THE FOLLOWING ROADWAY STANDARDS AS APPEAR IN "ROADWAY STANDARD DRAWINGS" - PROJECT SERVICES UNIT - N.C. DEPARTMENT OF TRANSPORTATION - RALEIGH, N.C., DATED JANUARY 2012 ARE APPLICABLE TO THIS PROJECT AND BY REFERENCE HEREBY ARE CONSIDERED A PART OF THESE PLANS:

STD. NO.	TITLE
904.10	ORIENTATION OF GROUND MOUNTED SIGNS
904.50	MOUNTING OF TYPE 'D', 'E' AND 'F' SIGNS ON 'U' CHANNEL POSTS

PROJECT NOTES

1. DISPOSAL OF SIGN SYSTEM, U-CHANNEL
2. DISPOSAL OF SUPPORT, U-CHANNEL
3. RELOCATE SIGN, TYPE D
4. RELOCATE SIGN, TYPE E

INDEX

SHEET NO.	DESCRIPTION
SIGN-1	TITLE SHEET
SIGN-2	TYPE D SIGNS
SIGN-3	TYPE E AND F SIGNS
SIGN-4 thru 8	SIGN DETAIL SHEETS

PLAN PREPARED BY: N.C.D.O.T. SIGNING AND DELINEATION UNIT

A.I. Alqudwah, P.E. SIGNING & DELINEATION REGIONAL ENGINEER

D.M. Eaton SIGNING & DELINEATION PROJECT DESIGN ENGINEER

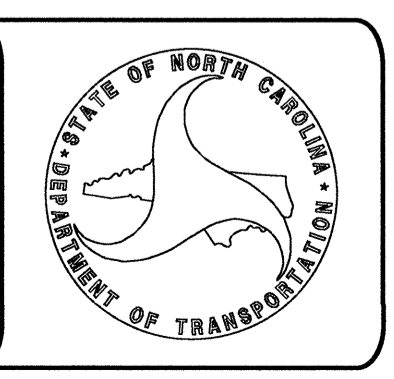

3/24/12 13:45 B4028-Traffic\Signing\CADD\Signing Layout Plans\B4028-Sgn-tsh.dgn

[Handwritten initials]

TIP NO. B-4028	SHEET NO. SIGN-2
APPROVED: <i>[Signature]</i>	
DATE: 4/26/12	
SEAL	



SIGN NUMR: 302,303 TYPE: D Ground QUANTITY: 2
 BACKG. COLOR: Green COPY COLOR: White
 DESIGN BY: DME PROJECT ID: B-4028
 CHK BY: AIA DIV: 6
 STD #: SSTN DATE: Apr 25, 2012

SIGN WIDTH: 3'-6" HEIGHT: 1'-6" TOTAL AREA: 5.3 Sq.Ft.
 MAT'L: 0.080" ALUMINUM
 BORDER TYPE: FLUSH RECESS: 0" WIDTH: 0.5" RADII: 1.5" NO. Z BARS: LENGTH:

SYMBOL	X	Y	WID	HT

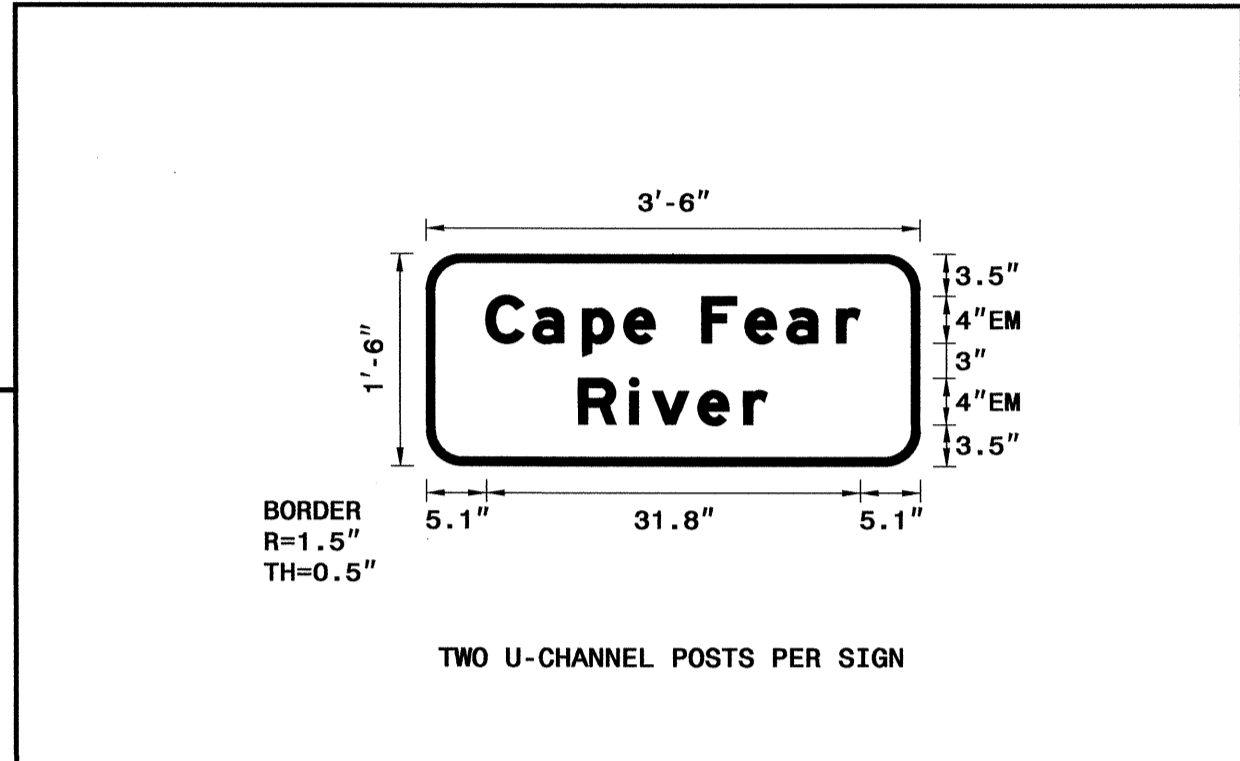

USE NOTES: 2,5
 1. Legend and border shall be direct applied Grade A reflective sheeting.
 2. Legend and border shall be direct applied Grade C reflective sheeting.
 3. Shields shall be Grade A reflective sheeting on 0.032" aluminum and demountable.
 4. Background shall be Grade B reflective sheeting.
 5. Background shall be Grade C reflective sheeting.
 6. Center arrow(s) vertically on sign.

Letter spacings are to start of next letter											Series/Size	Text Length
C	a	p	e	F	e	a	r				EM 2000	31.8
5.1	4	4.2	3.5	2.6	4	3.7	3.5	4.2	2	5.1	EM 2000	16
R i v e r											EM 2000	16

Spacing Factor is 1 unless specified otherwise
 FILENAME: GSENG

SIGN NUMR: 301 TYPE: D Ground QUANTITY: 1
 BACKG. COLOR: Green COPY COLOR: White
 DESIGN BY: DME PROJECT ID: B-4028
 CHK BY: AIA DIV: 6
 STD #: SSTN DATE: Mar 28, 2012

SIGN WIDTH: 4'-0" HEIGHT: 2'-0" TOTAL AREA: 8.0 Sq.Ft.
 MAT'L: 0.125" ALUMINUM
 BORDER TYPE: FLUSH RECESS: 0" WIDTH: 0.5" RADII: 3" NO. Z BARS: LENGTH:

SYMBOL	X	Y	WID	HT

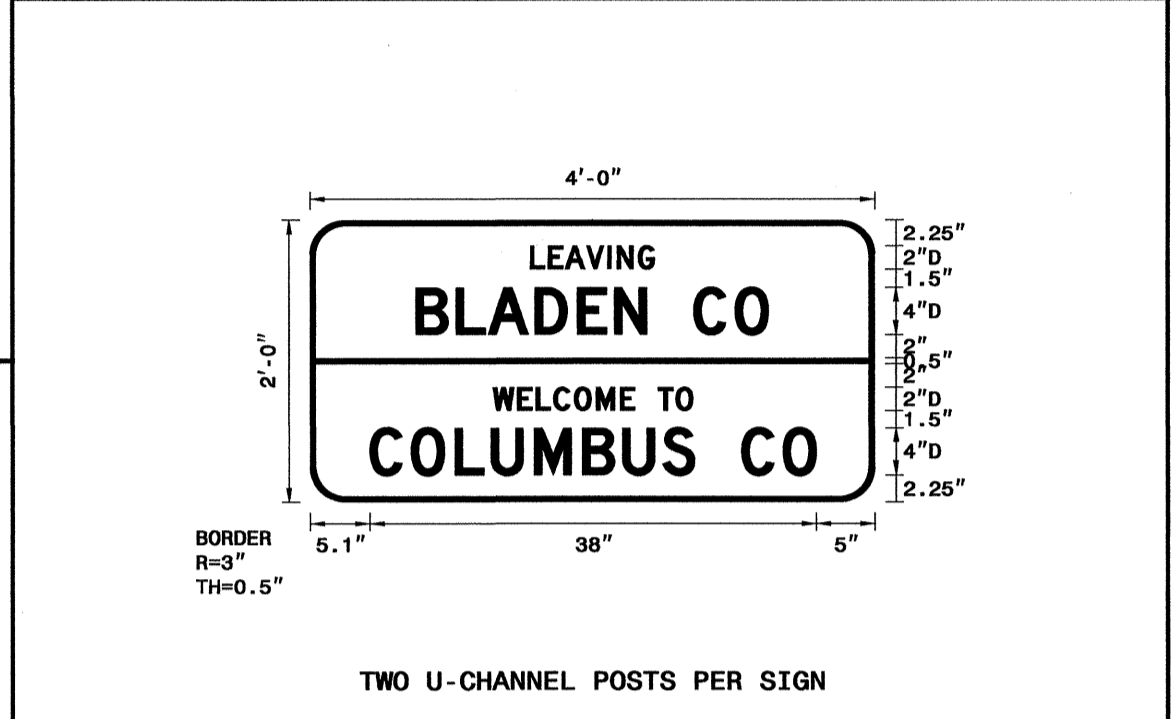

USE NOTES: 2,5
 1. Legend and border shall be direct applied Grade A reflective sheeting.
 2. Legend and border shall be direct applied Grade C reflective sheeting.
 3. Shields shall be Grade A reflective sheeting on 0.032" aluminum and demountable.
 4. Background shall be Grade B reflective sheeting.
 5. Background shall be Grade C reflective sheeting.
 6. Center arrow(s) vertically on sign.

Letter spacings are to start of next letter											Series/Size	Text Length	
L	E	A	V	I	N	G					D 2000	10.5	
18.7	1.5	1.4	1.8	1.8	0.8	1.8	1.4	18.7			D 2000	30	
9	3.4	2.7	4	3.6	3.2	2.7	4	3.5	2.8	9	D 2000	17	
15.6	2.1	1.6	1.5	1.8	1.9	2	1.2	2	1.5	1.4	15.6	D 2000	38
5.1	3.5	3.7	3.1	3.7	4.1	3.4	3.4	2.7	4	3.5	2.8	5	

Spacing Factor is 1 unless specified otherwise
 FILENAME: GSENG

SIGN NUMR: 305 TYPE: D Ground QUANTITY: 1
 BACKG. COLOR: Green COPY COLOR: White
 DESIGN BY: DME PROJECT ID: B-4028
 CHK BY: AIA DIV: 6
 STD #: SSTN DATE: Apr 25, 2012

SIGN WIDTH: 3'-6" HEIGHT: 1'-6" TOTAL AREA: 5.3 Sq.Ft.
 MAT'L: 0.080" ALUMINUM
 BORDER TYPE: FLUSH RECESS: 0" WIDTH: 0.5" RADII: 1.5" NO. Z BARS: LENGTH:

SYMBOL	X	Y	WID	HT

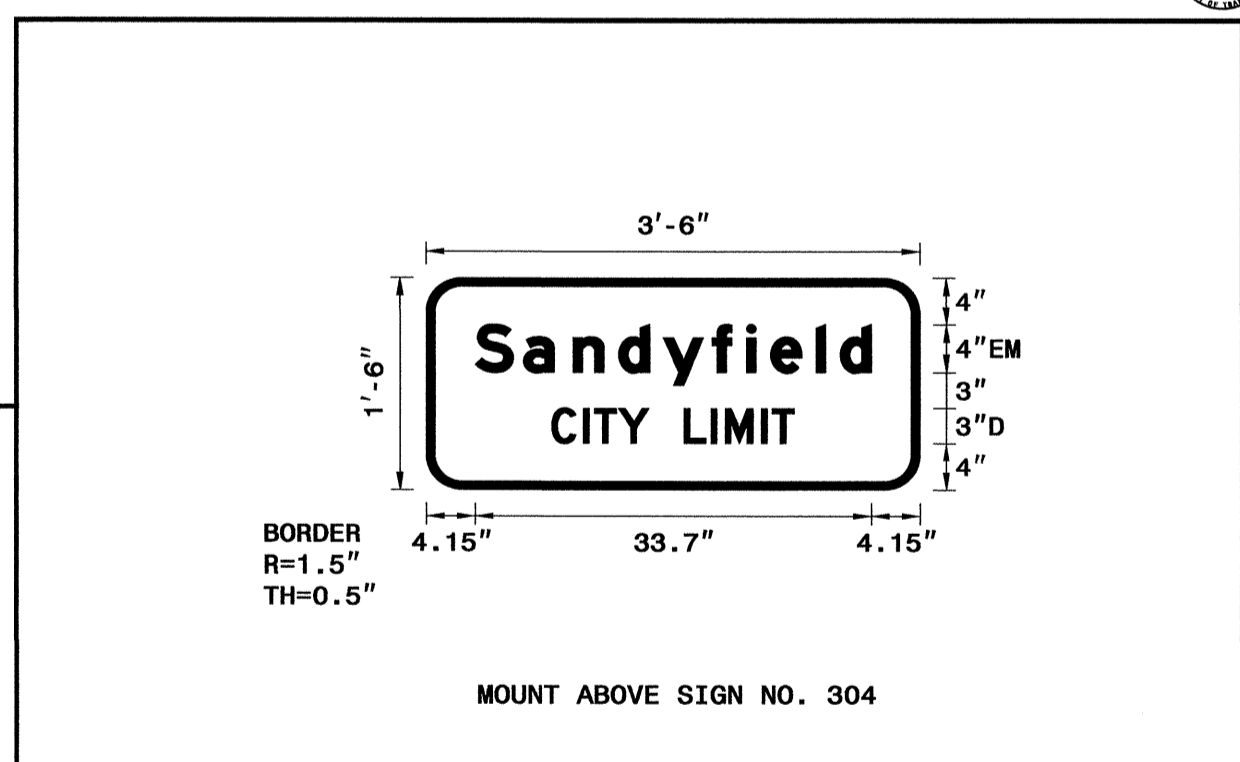

USE NOTES: 2,5
 1. Legend and border shall be direct applied Grade A reflective sheeting.
 2. Legend and border shall be direct applied Grade C reflective sheeting.
 3. Shields shall be Grade A reflective sheeting on 0.032" aluminum and demountable.
 4. Background shall be Grade B reflective sheeting.
 5. Background shall be Grade C reflective sheeting.
 6. Center arrow(s) vertically on sign.

Letter spacings are to start of next letter											Series/Size	Text Length	
S	a	n	d	y	f	i	e	l	d		EM 2000	33.7	
4.1	4.1	4.2	3.9	3.8	4.2	2.9	2	3.9	2	2.6	4.1	D 2000	20.6
C I T Y L I M I T											D 2000	20.6	
10.7	2.7	0.9	2	2.6	3	2.3	1.2	3.1	0.9	1.9	10.7		

Spacing Factor is 1 unless specified otherwise
 FILENAME: GSENG

SIGN NUMR: 304 TYPE: D Ground QUANTITY: 1
 BACKG. COLOR: Green COPY COLOR: White
 DESIGN BY: DME PROJECT ID: B-4028
 CHK BY: AIA DIV: 6
 STD #: SSTN DATE: Mar 28, 2012

SIGN WIDTH: 4'-0" HEIGHT: 2'-0" TOTAL AREA: 8.0 Sq.Ft.
 MAT'L: 0.125" ALUMINUM
 BORDER TYPE: FLUSH RECESS: 0" WIDTH: 0.5" RADII: 3" NO. Z BARS: LENGTH:

SYMBOL	X	Y	WID	HT

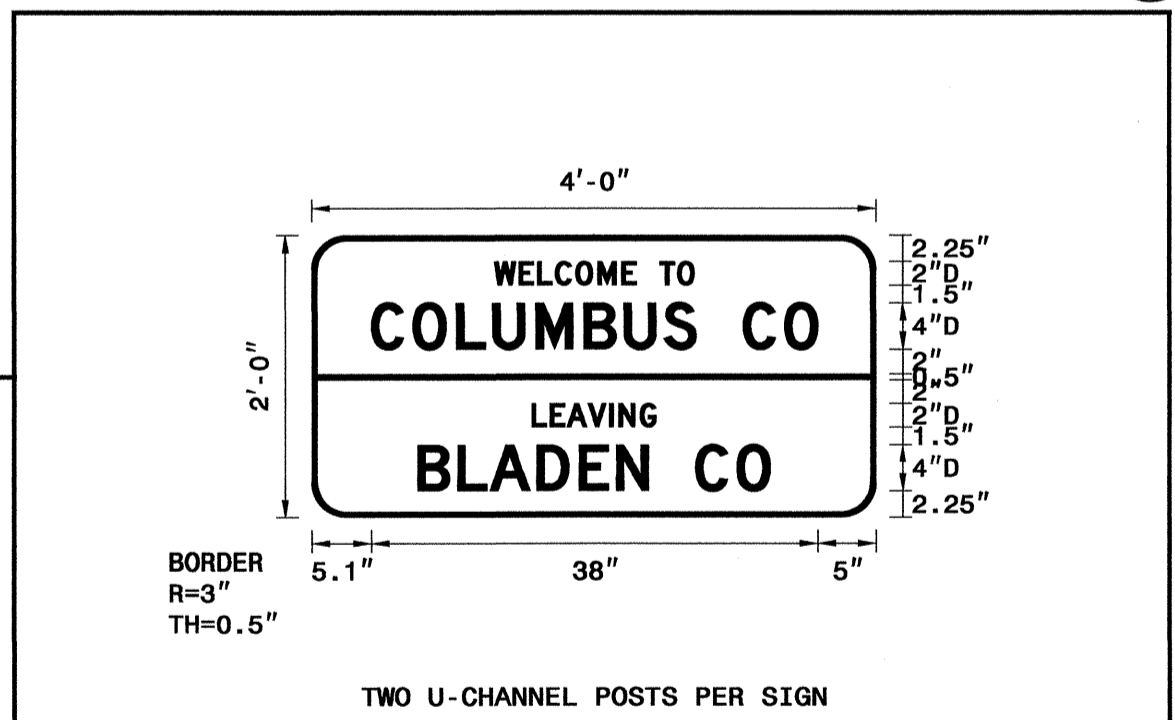

USE NOTES: 2,5
 1. Legend and border shall be direct applied Grade A reflective sheeting.
 2. Legend and border shall be direct applied Grade C reflective sheeting.
 3. Shields shall be Grade A reflective sheeting on 0.032" aluminum and demountable.
 4. Background shall be Grade B reflective sheeting.
 5. Background shall be Grade C reflective sheeting.
 6. Center arrow(s) vertically on sign.

Letter spacings are to start of next letter											Series/Size	Text Length	
W	E	L	C	O	M	E	T	O			D 2000	17	
15.6	2.1	1.6	1.5	1.8	1.9	2	1.2	2	1.5	1.4	15.6	D 2000	38
5.1	3.5	3.7	3.1	3.7	4.1	3.4	3.4	2.7	4	3.5	2.8	5	
18.7	1.5	1.4	1.8	1.8	0.8	1.8	1.4	18.7			D 2000	10.5	
9	3.4	2.7	4	3.6	3.2	2.7	4	3.5	2.8	9	D 2000	30	

Spacing Factor is 1 unless specified otherwise
 FILENAME: GSENG

25-APP-2012 14:49
 PK:\IPR\Projects\B-4028\Traffic\Signing\CA00\Sign Designs\B-4028_sgn_sgn_desi.gns.dgn
 meator AI 12/17/08

TYPE D SIGNS

APPROVED: *[Signature]*
 DATE: 4/26/12

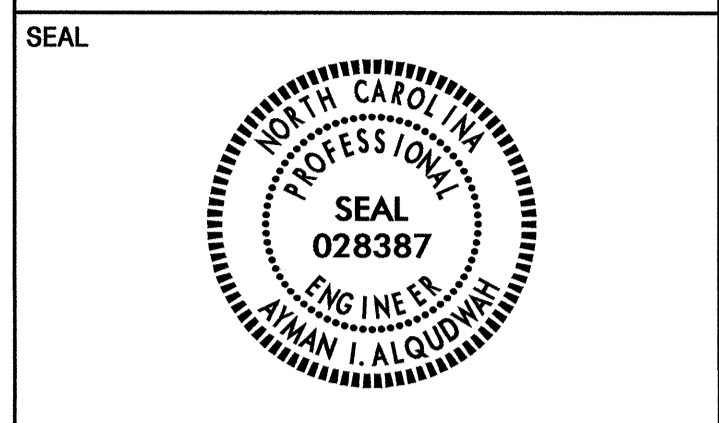

401 QUANTITY REQ'D 1

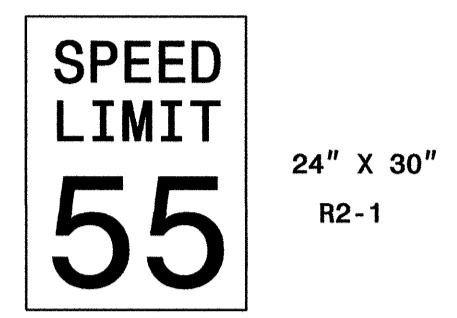

ONE "U" POST PER SIGN

501 QUANTITY REQ'D 1

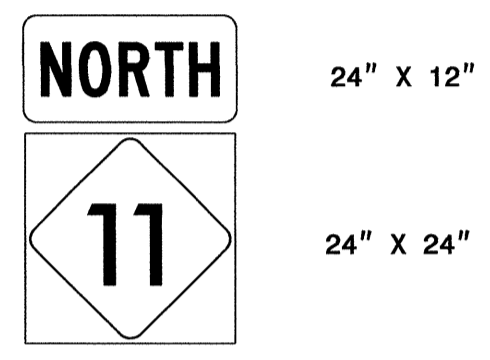

ONE "U" POST PER SIGN

TYPE "E" or "F" SIGNS

TIP NO. B-4028	SHEET NO. SIGN-4
APPROVED: <i>[Signature]</i>	
DATE: 4/26/12	
SEAL	
	

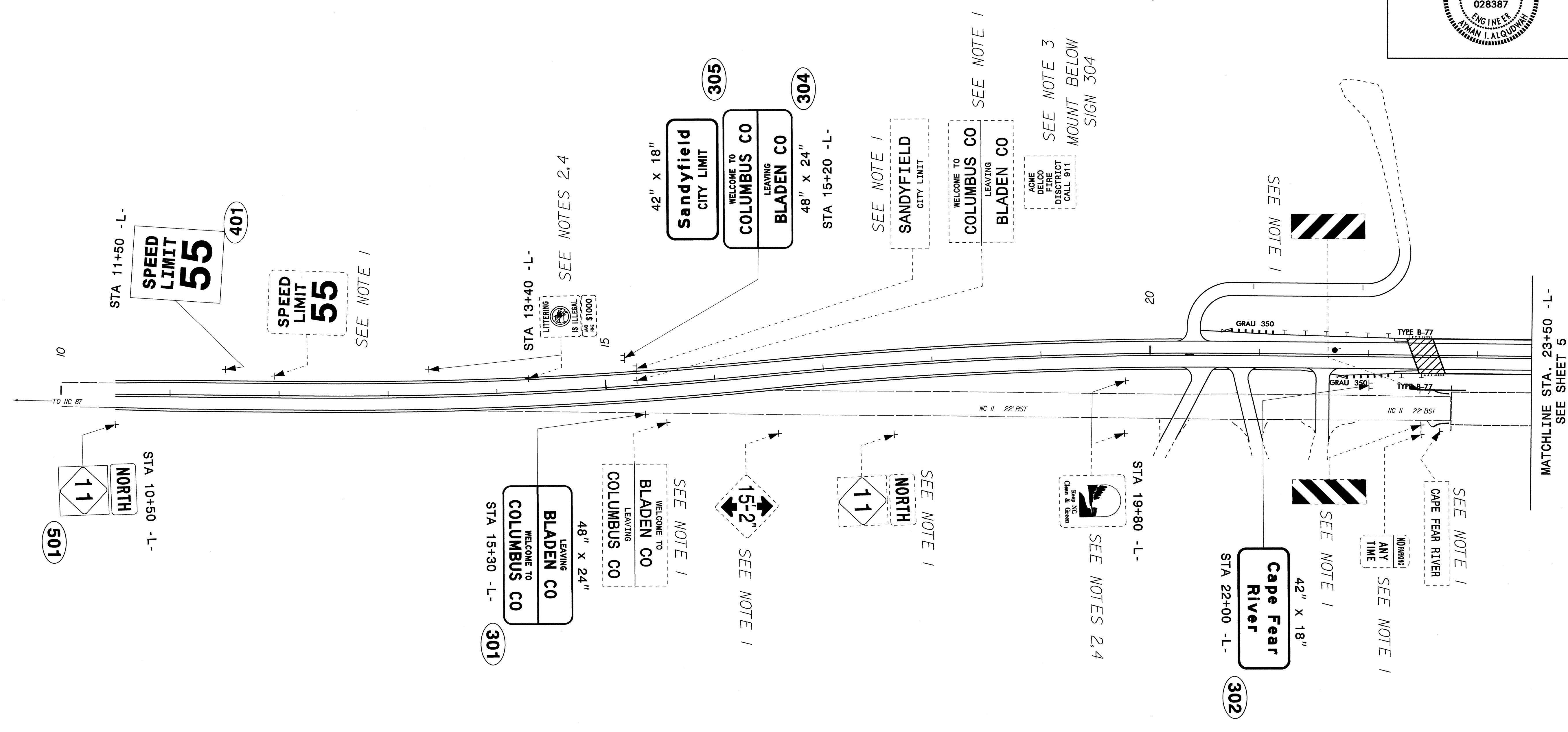
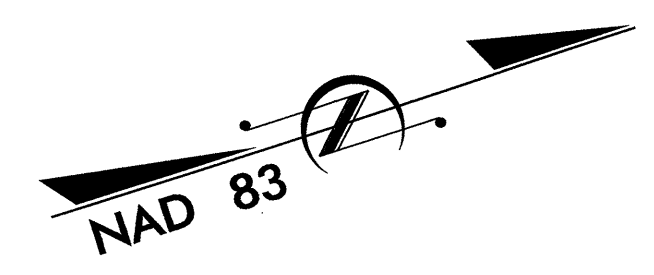

PROJECT NOTES

1. DISPOSAL OF SIGN SYSTEM, U-CHANNEL
2. DISPOSAL OF SUPPORT, U-CHANNEL
3. RELOCATE SIGN, TYPE D
4. RELOCATE SIGN, TYPE E

EXISTING AND PROPOSED SIGNS

25-APR-2012 14:50
 P:\TIP-projects\B4028\Traffic\Signing\CADD\Signing_Layout_Plans\B4028_Sgn_psh.dgn
 meaton

TIP NO. B-4028	SHEET NO. SIGN-5
APPROVED: <i>[Signature]</i>	
DATE: 4/26/12	
SEAL	

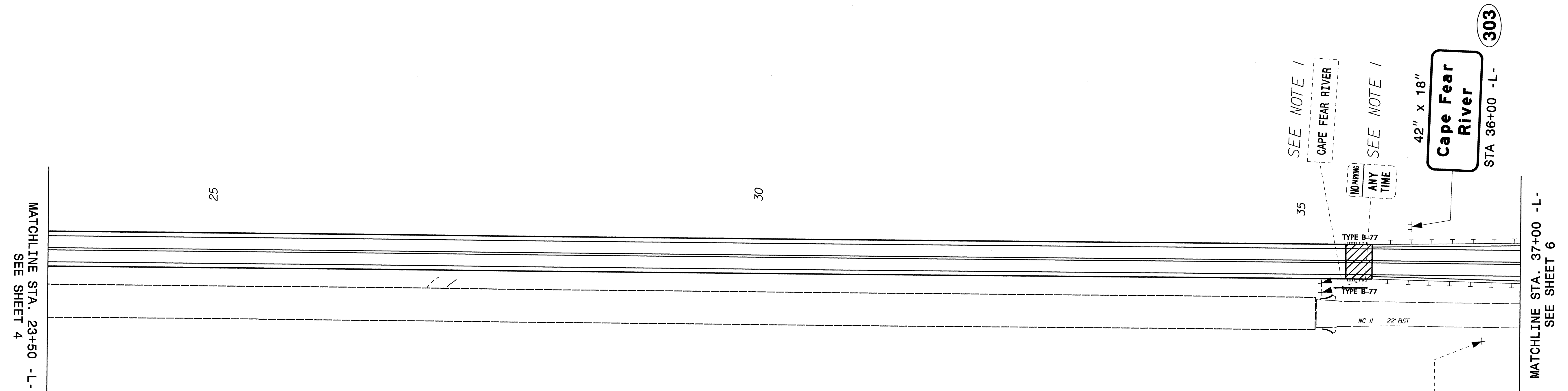
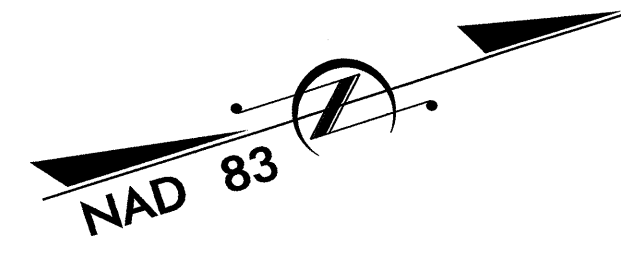

PROJECT NOTES

1. DISPOSAL OF SIGN SYSTEM, U-CHANNEL
2. DISPOSAL OF SUPPORT, U-CHANNEL
3. RELOCATE SIGN, TYPE D
4. RELOCATE SIGN, TYPE E

EXISTING AND PROPOSED SIGNS

25-APP-2012 14452
 P:\TIP-Proj\0428\B-4028\Traffic\Signing\CA00\Signing Layout\Plans\B4028_Sgn_psh2.dgn
 meason AT 11/27/08

TIP NO. B-4028	SHEET NO. SIGN-6
APPROVED: <i>Alman Alquodhi</i>	
DATE: 4/26/12	
SEAL	

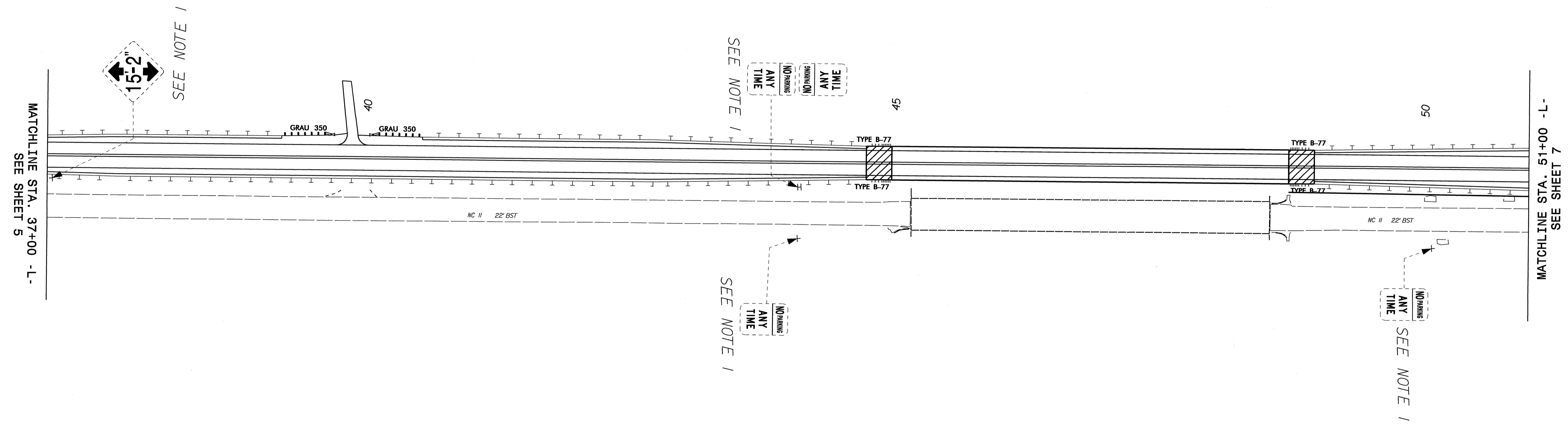
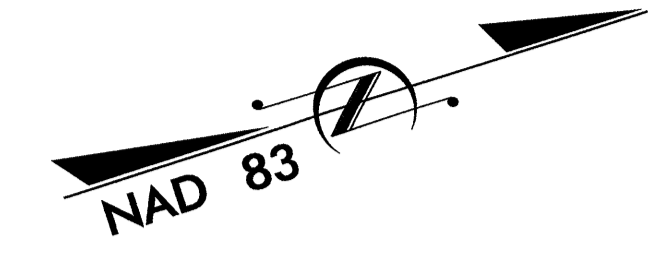

PROJECT NOTES

1. DISPOSAL OF SIGN SYSTEM, U-CHANNEL
2. DISPOSAL OF SUPPORT, U-CHANNEL
3. RELOCATE SIGN, TYPE D
4. RELOCATE SIGN, TYPE E

EXISTING AND PROPOSED SIGNS

23-APR-2012 13:46 B:\B4028\Traffic\Signing\CADD\Signing Layout Plans\B4028_Sgn_psh3.dgn
 meatorn AT LE 27908

TIP NO. B-4028	SHEET NO. SIGN-7
APPROVED: <i>Alman Al-Qudus</i>	
DATE: 4/26/12	
SEAL	
	

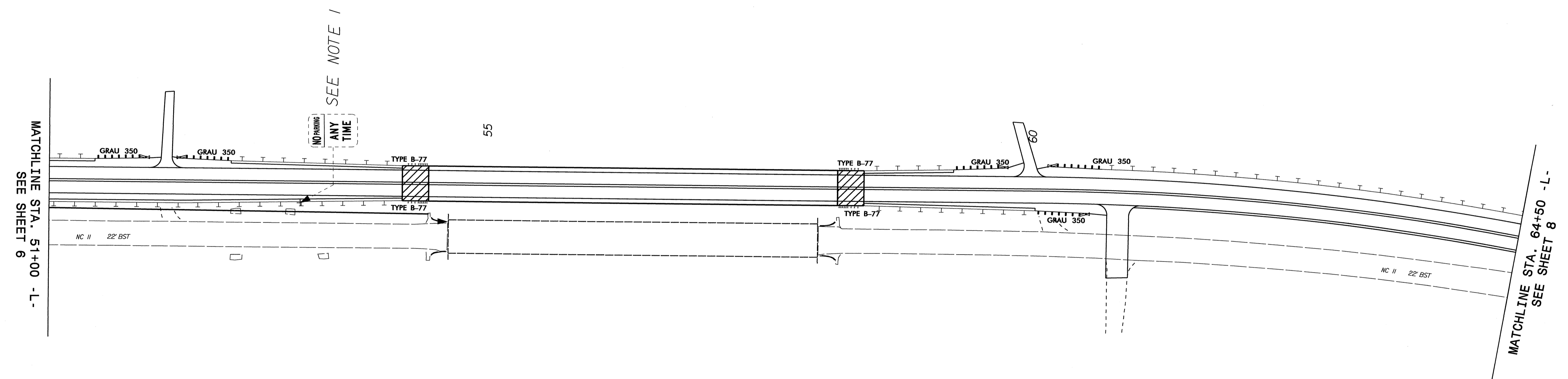
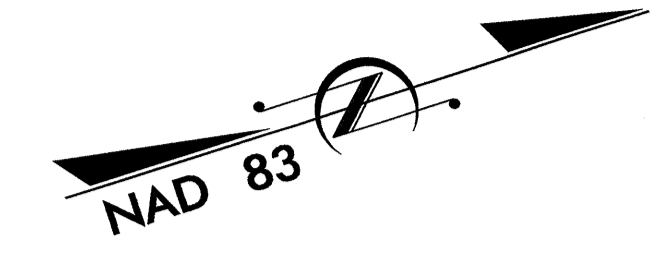



PROJECT NOTES

1. DISPOSAL OF SIGN SYSTEM, U-CHANNEL
2. DISPOSAL OF SUPPORT, U-CHANNEL
3. RELOCATE SIGN, TYPE D
4. RELOCATE SIGN, TYPE E

EXISTING AND PROPOSED SIGNS

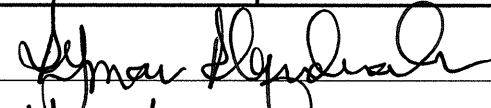
27 APR 2012 13:55
 C:\p1\p1\p1\B4028\Traffic\Signing\CADD\Signing Layout Plans\B4028_Sgn_psh4.dgn
 neaton PA E27308

TIP NO. B-4028	SHEET NO. SIGN-8
APPROVED: 	
DATE: 4/26/12	
SEAL 	

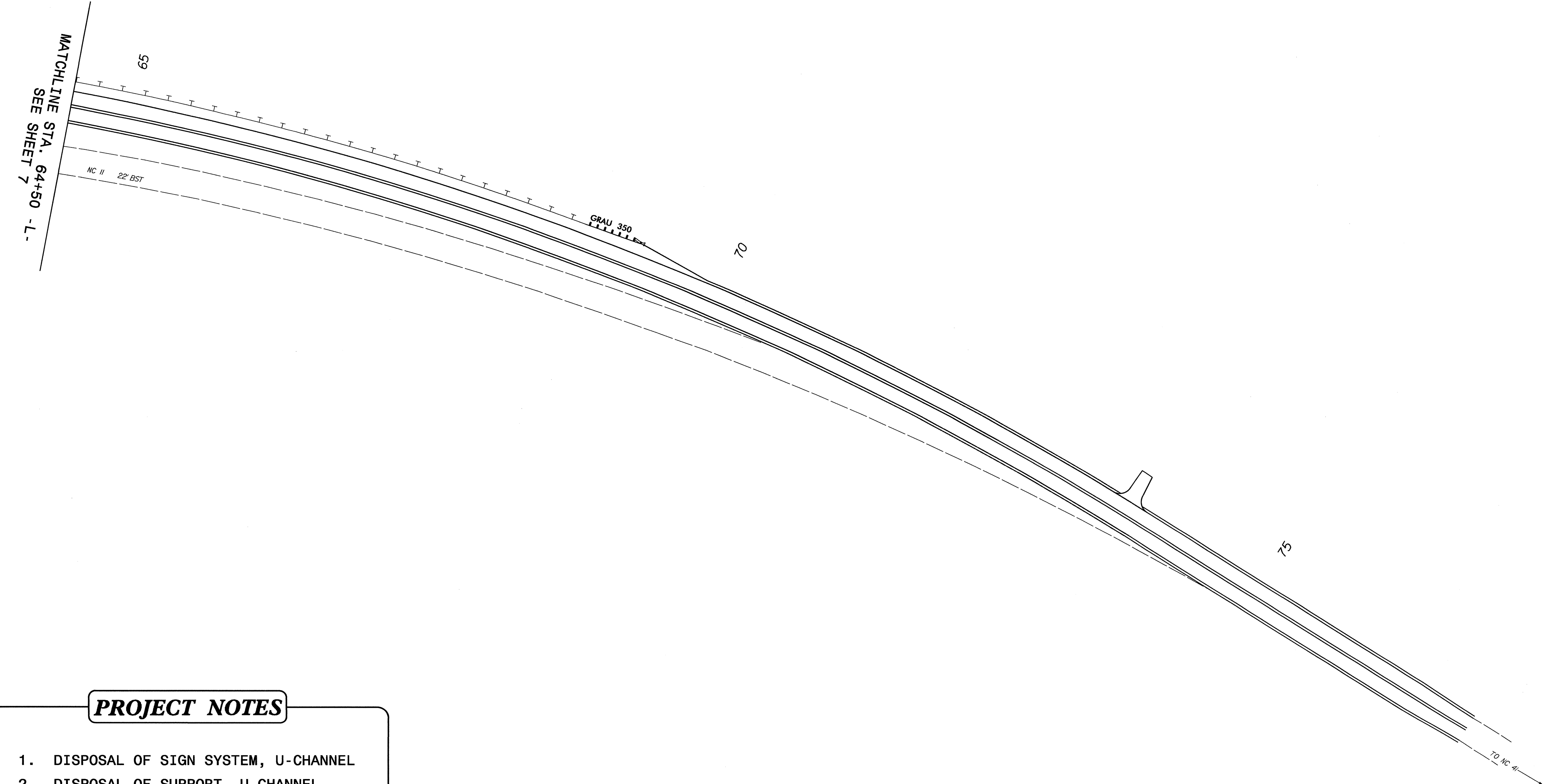
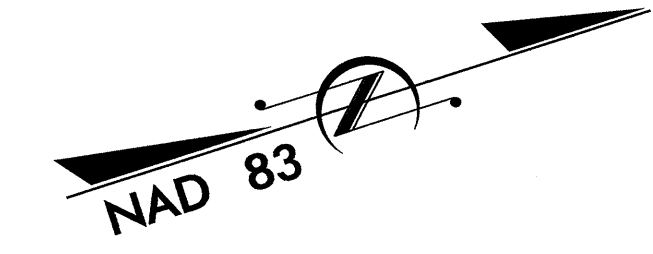

PROJECT NOTES

- 1. DISPOSAL OF SIGN SYSTEM, U-CHANNEL
- 2. DISPOSAL OF SUPPORT, U-CHANNEL
- 3. RELOCATE SIGN, TYPE D
- 4. RELOCATE SIGN, TYPE E

EXISTING AND PROPOSED SIGNS