

PROJECT REFERENCE NO.	SHEET NO.
5CR.10921.41	1
5CR.20921.41	

1

2

WAKE COUNTY

6/2/99

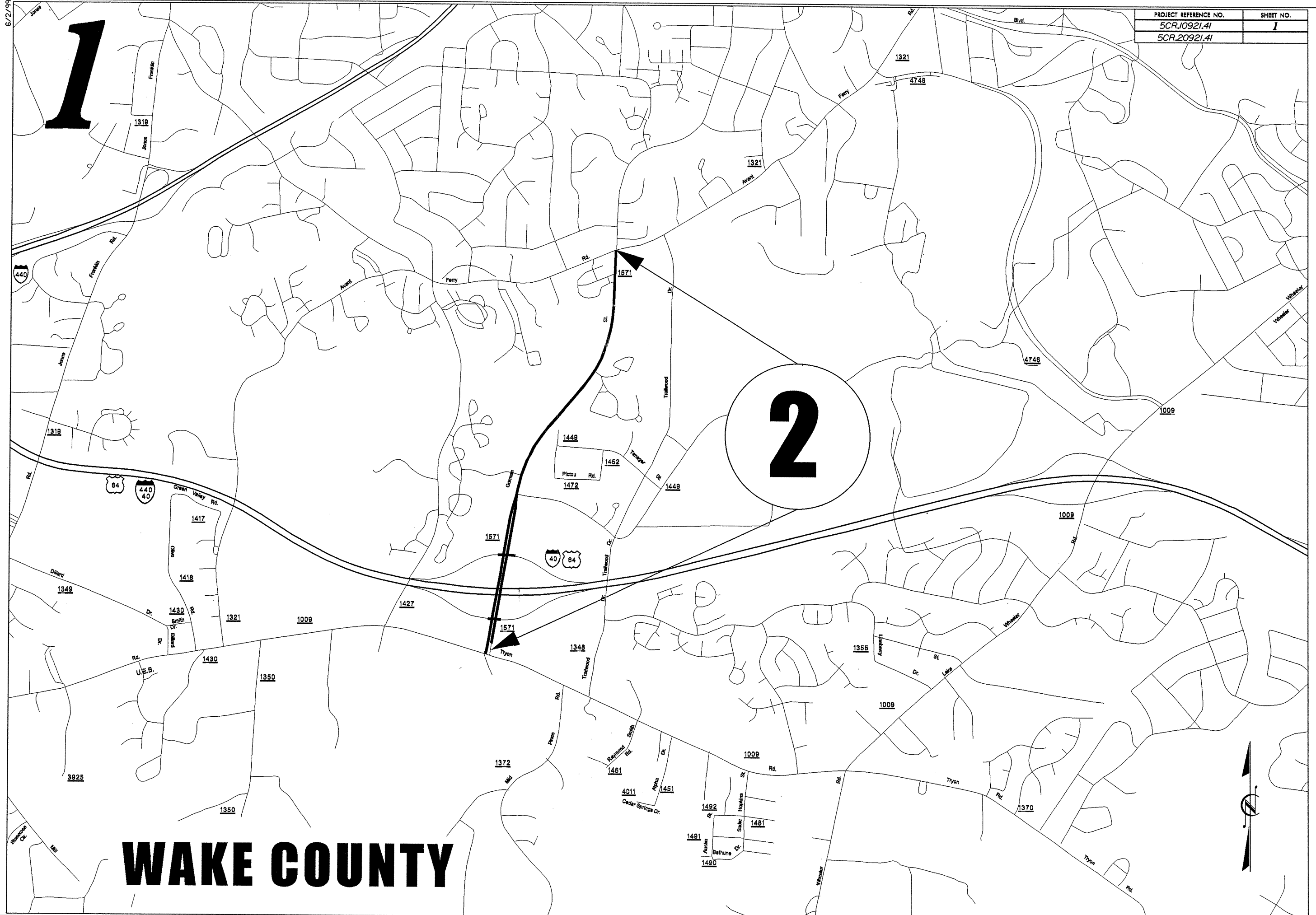

3

1A

1B

RALEIGH
POP. 338,669

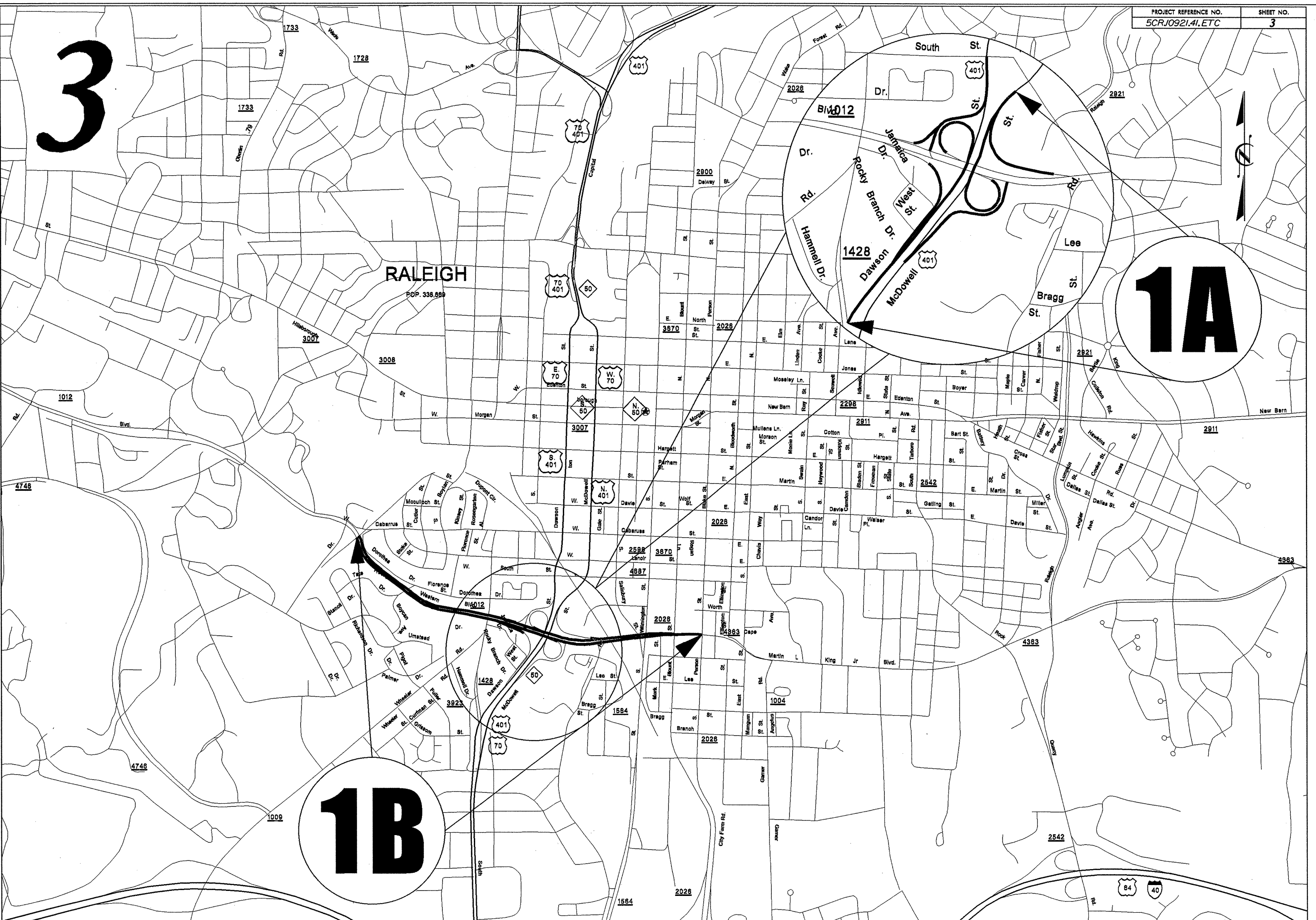

6/2/99

5

6

7

6

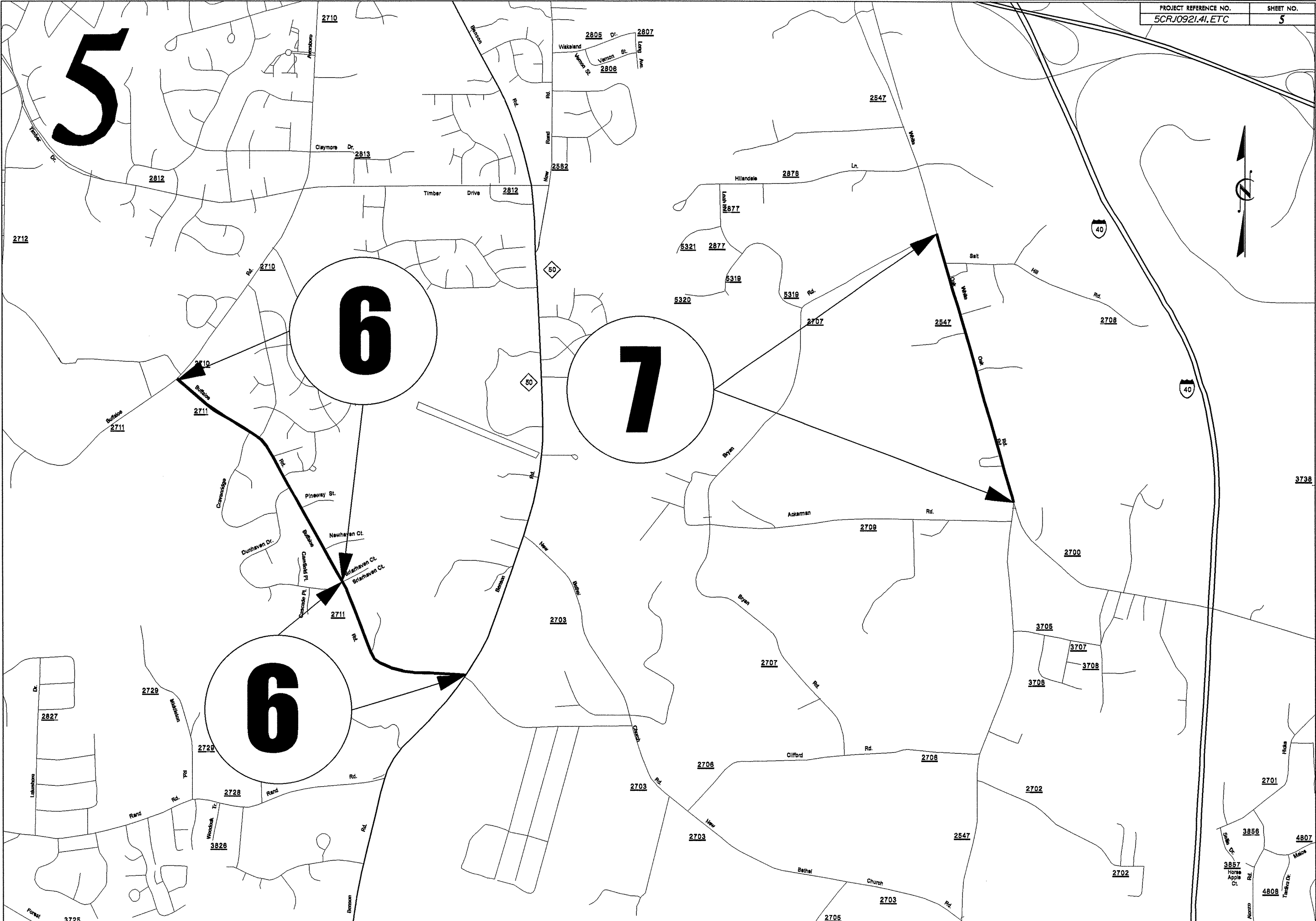

3738

3856
3857 Horse Apple Ct
4807
4808
4809

2712

2812

2710

2813

2812

2582

2805

2807

2808

2547

2878

2877

5321

2877

5319

5320

5319

2707

2547

2708

2710

2711

2711

Rt 2710

Cornwall

Piney St.

Durham Dr.

Stables

Newman Ct.

Camfield Pt.

Brathaven Ct.

Brathaven Ct.

2711

50

7

Bryan

Ackerman

2709

2700

2707

3705

3707

3708

3706

2729

2827

2729

2728

2728

3826

2703

2703

2706

2706

2703

2547

2702

2701

2702

2703

2705

3725

6/2/99

6

8

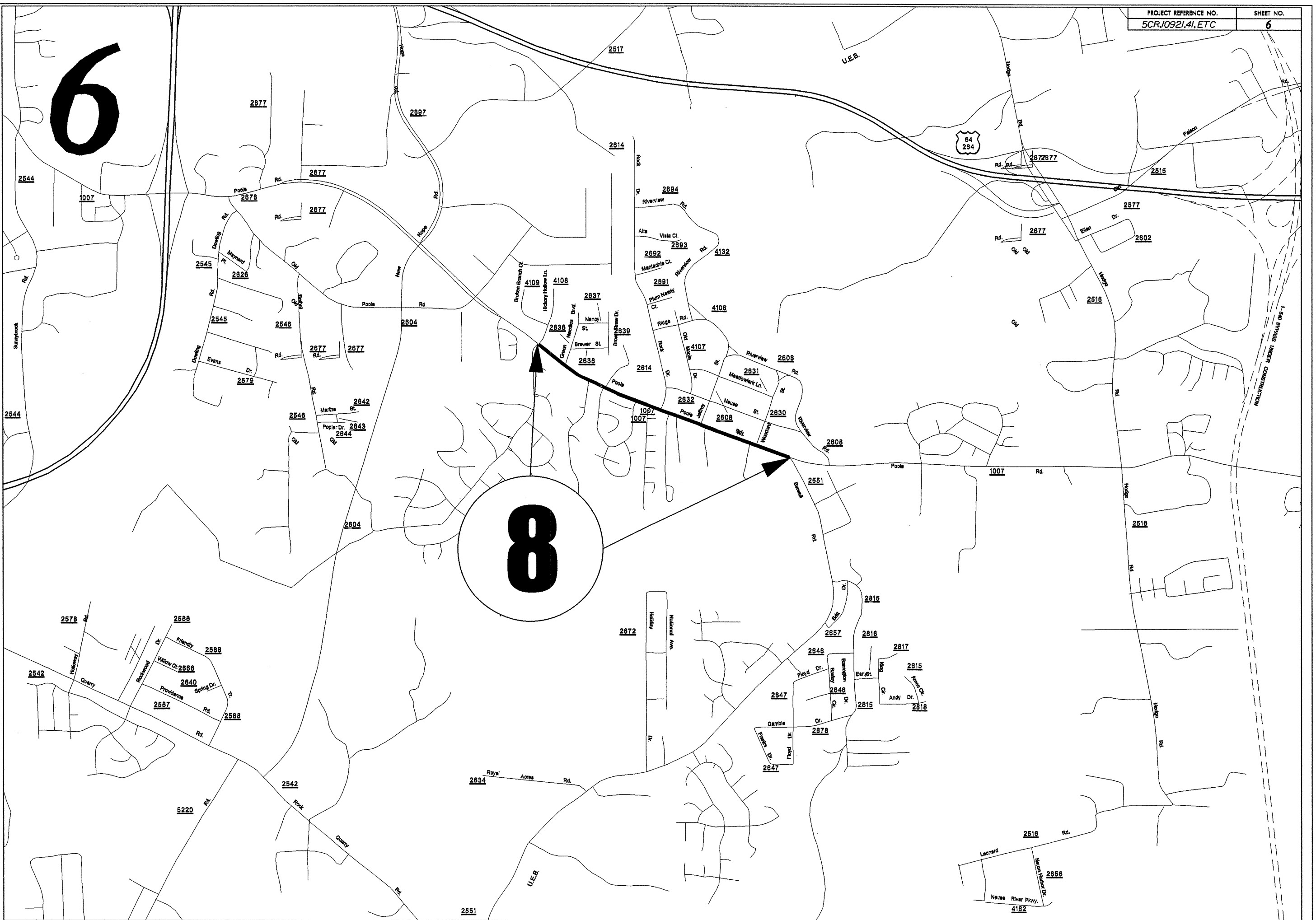

PAVEMENT SCHEDULE

C1	1½" ASPHALT CONCRETE SURFACE COURSE, TYPE S9.5B, AT AN AVERAGE RATE OF 168 LBS. PER SQ. YD.
C2	1¼" ASPHALT CONCRETE SURFACE COURSE, TYPE SF9.5A, AT AN AVERAGE RATE OF 137.5 LBS. PER SQ. YD.
D	2½" ASPHALT CONCRETE INTERMEDIATE COURSE, TYPE I19.0B, AT AN AVERAGE RATE OF 285 LBS. PER SQ. YD.
E	5.5" ASPHALT CONCRETE BASE COURSE, TYPE B25.0B, AT AN AVERAGE RATE OF 627 LBS. PER SQ. YD.
S	PROP. SHOULDER GRADING
U	EXISTING PAVEMENT
V1	1½" MILLING
V2	2½" MILLING
V3	2½" - 4" MILLING NEW ASPHALT TO BE PAVED BACK FLUSH
V4	0" - 1½" MILLING NEW ASPHALT TO BE PAVED BACK FLUSH

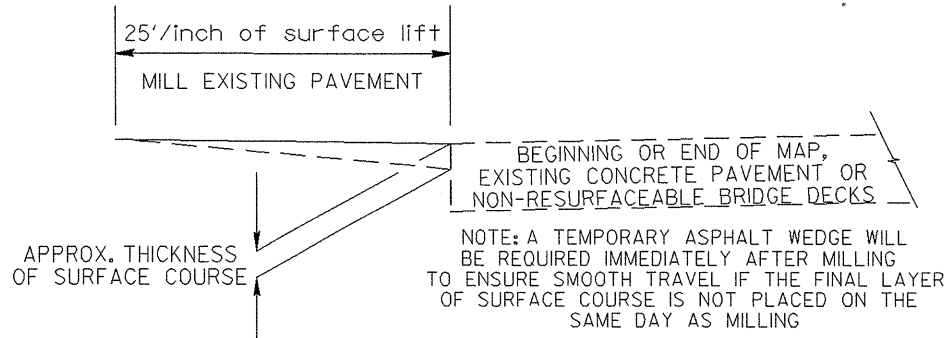

INCIDENTAL MILLING

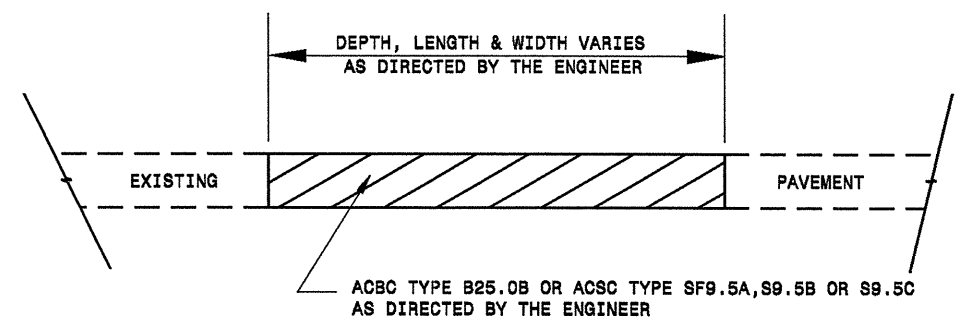

PATCHING EXISTING PAVEMENT

PATCHING TO BE PERFORMED PRIOR TO MILL AND FILL OPERATION

NOTES

ALL UNPAVED S.R. ROADS TO BE RESURFACED 50' FROM EDGE OF PAVEMENT OF MAIN PROJECT

ALL PAVED S.R. ROADS TO BE RESURFACED TO THE ENDS OF THE RADII, OR AS DIRECTED BY THE ENGINEER.

EDGES, PAVEMENT WIDENING, INTERSECTIONS AND BRIDGE FLARES ARE INCLUDED IN THE TABLE OF QUANTITIES.

BRIDGES TO BE RESURFACED AT LOCATIONS AND TO DEPTH AS DIRECTED BY THE ENGINEER.

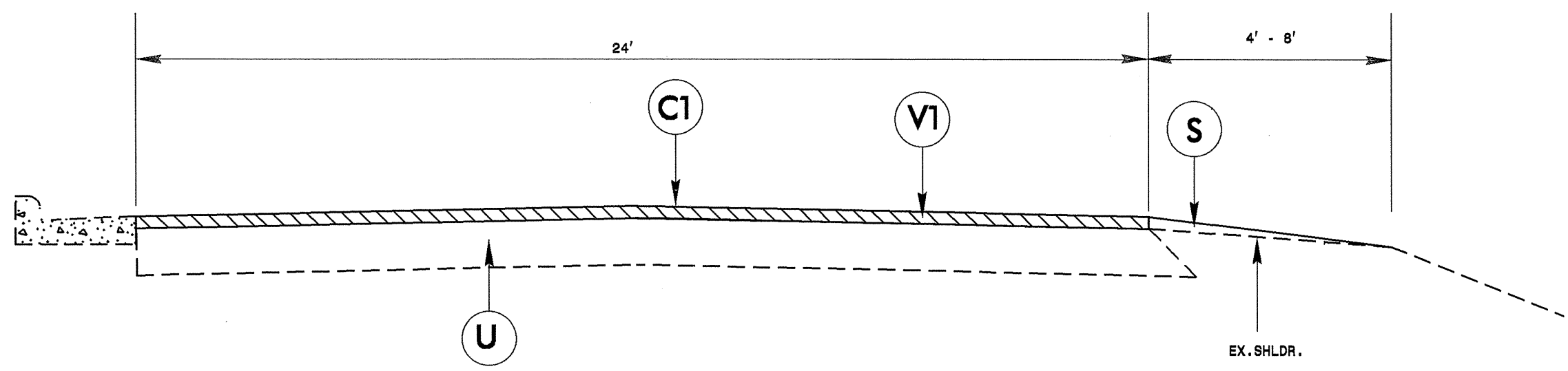

TYPICAL SECTION NO. 1

PAVEMENT SCHEDULE

C1	1½" ASPHALT CONCRETE SURFACE COURSE, TYPE S9.5B, AT AN AVERAGE RATE OF 168 LBS. PER SQ. YD.
C2	1¼" ASPHALT CONCRETE SURFACE COURSE, TYPE SF9.5A, AT AN AVERAGE RATE OF 137.5 LBS. PER SQ. YD.
D	2½" ASPHALT CONCRETE INTERMEDIATE COURSE, TYPE I19.0B, AT AN AVERAGE RATE OF 285 LBS. PER SQ. YD.
E	5.5" ASPHALT CONCRETE BASE COURSE, TYPE B25.0B, AT AN AVERAGE RATE OF 627 LBS. PER SQ. YD.
S	PROP. SHOULDER GRADING
U	EXISTING PAVEMENT
V1	1½" MILLING
V2	2½" MILLING
V3	2½" - 4" MILLING NEW ASPHALT TO BE PAVED BACK FLUSH
V4	0" - 1½" MILLING NEW ASPHALT TO BE PAVED BACK FLUSH

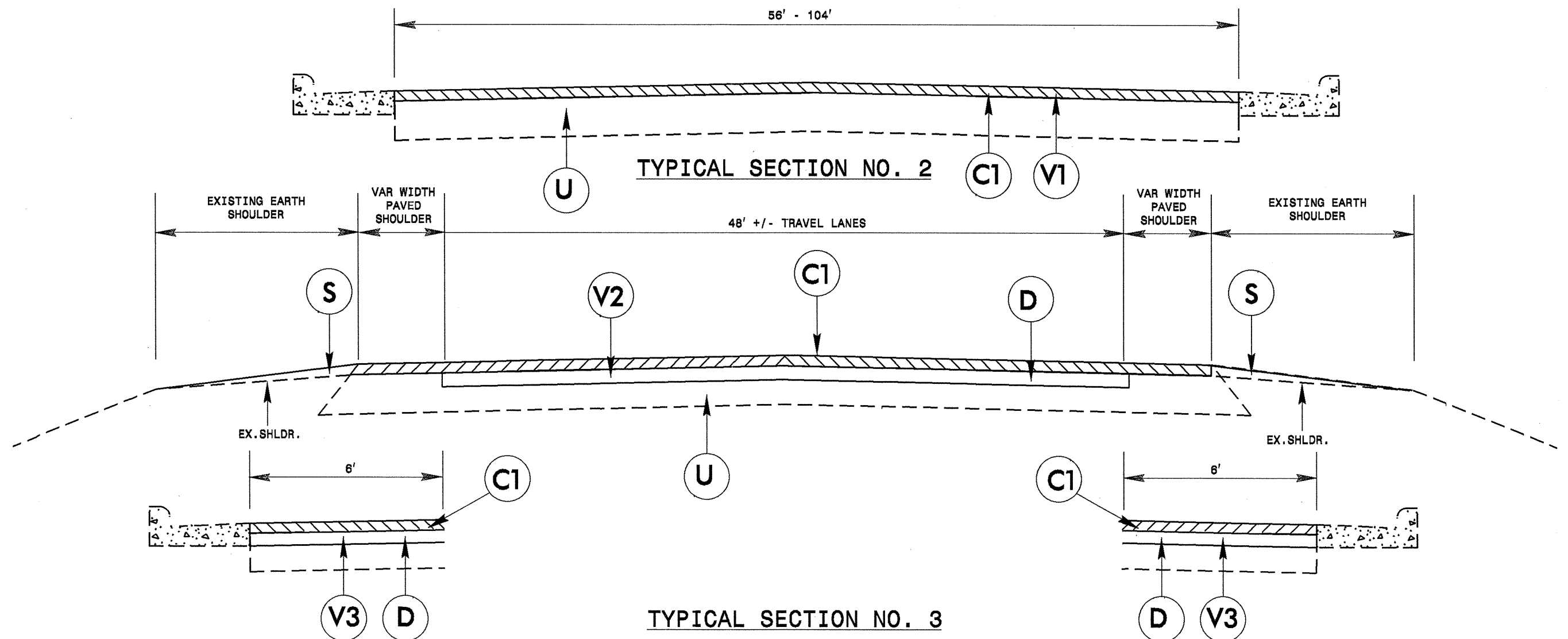

PAVEMENT SCHEDULE

C1	1½" ASPHALT CONCRETE SURFACE COURSE, TYPE S9.5B, AT AN AVERAGE RATE OF 168 LBS. PER SQ. YD.
C2	1¼" ASPHALT CONCRETE SURFACE COURSE, TYPE SF9.5A, AT AN AVERAGE RATE OF 137.5 LBS. PER SQ. YD.
D	2½" ASPHALT CONCRETE INTERMEDIATE COURSE, TYPE I19.0B, AT AN AVERAGE RATE OF 285 LBS. PER SQ. YD.
E	5.5" ASPHALT CONCRETE BASE COURSE, TYPE B25.0B, AT AN AVERAGE RATE OF 627 LBS. PER SQ. YD.
S	PROP. SHOULDER GRADING
U	EXISTING PAVEMENT
V1	1½" MILLING
V2	2½" MILLING
V3	2½" - 4" MILLING NEW ASPHALT TO BE PAVED BACK FLUSH
V4	0" - 1½" MILLING NEW ASPHALT TO BE PAVED BACK FLUSH

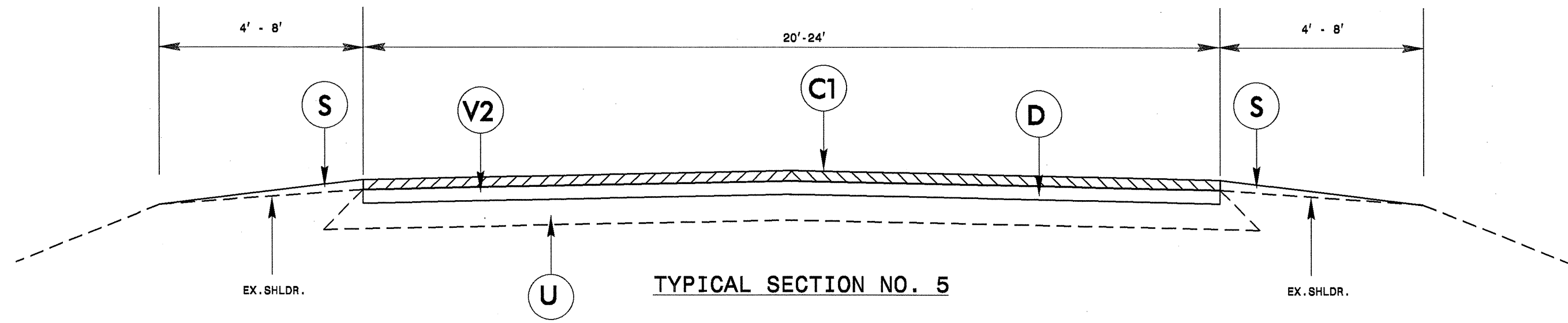
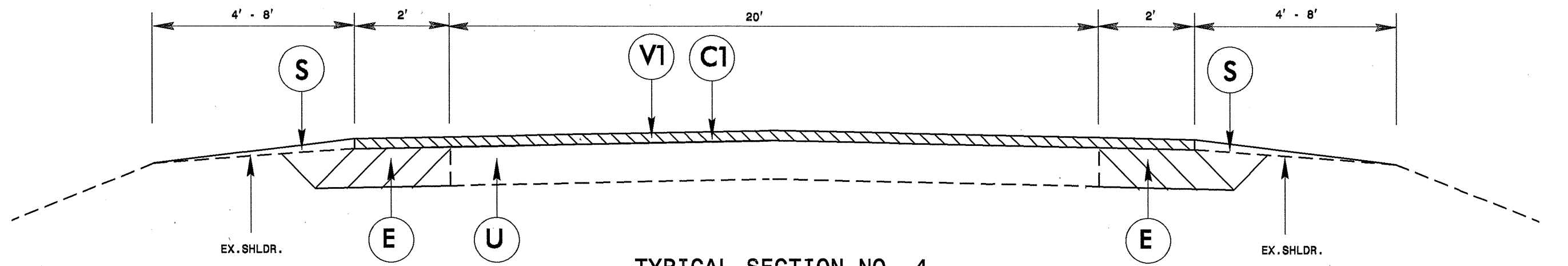

PAVEMENT SCHEDULE

C1	1½" ASPHALT CONCRETE SURFACE COURSE, TYPE S9.5B, AT AN AVERAGE RATE OF 188 LBS. PER SQ. YD.
C2	1¼" ASPHALT CONCRETE SURFACE COURSE, TYPE SF9.5A, AT AN AVERAGE RATE OF 137.5 LBS. PER SQ. YD.
D	2½" ASPHALT CONCRETE INTERMEDIATE COURSE, TYPE I19.0B, AT AN AVERAGE RATE OF 285 LBS. PER SQ. YD.
E	5.5" ASPHALT CONCRETE BASE COURSE, TYPE B25.0B, AT AN AVERAGE RATE OF 627 LBS. PER SQ. YD.
S	PROP. SHOULDER GRADING
U	EXISTING PAVEMENT
V1	1½" MILLING
V2	2½" MILLING
V3	2½" - 4" MILLING NEW ASPHALT TO BE PAVED BACK FLUSH
V4	0" - 1½" MILLING NEW ASPHALT TO BE PAVED BACK FLUSH

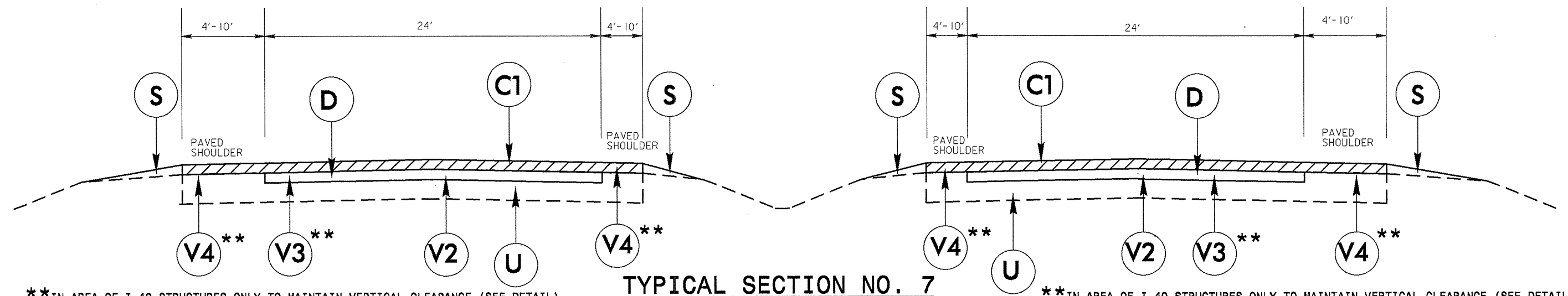
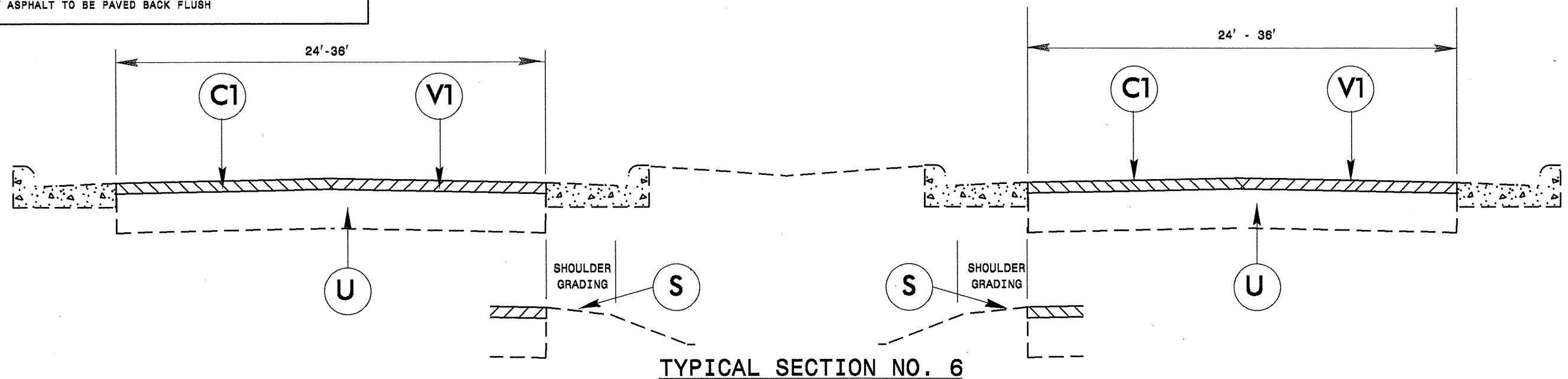
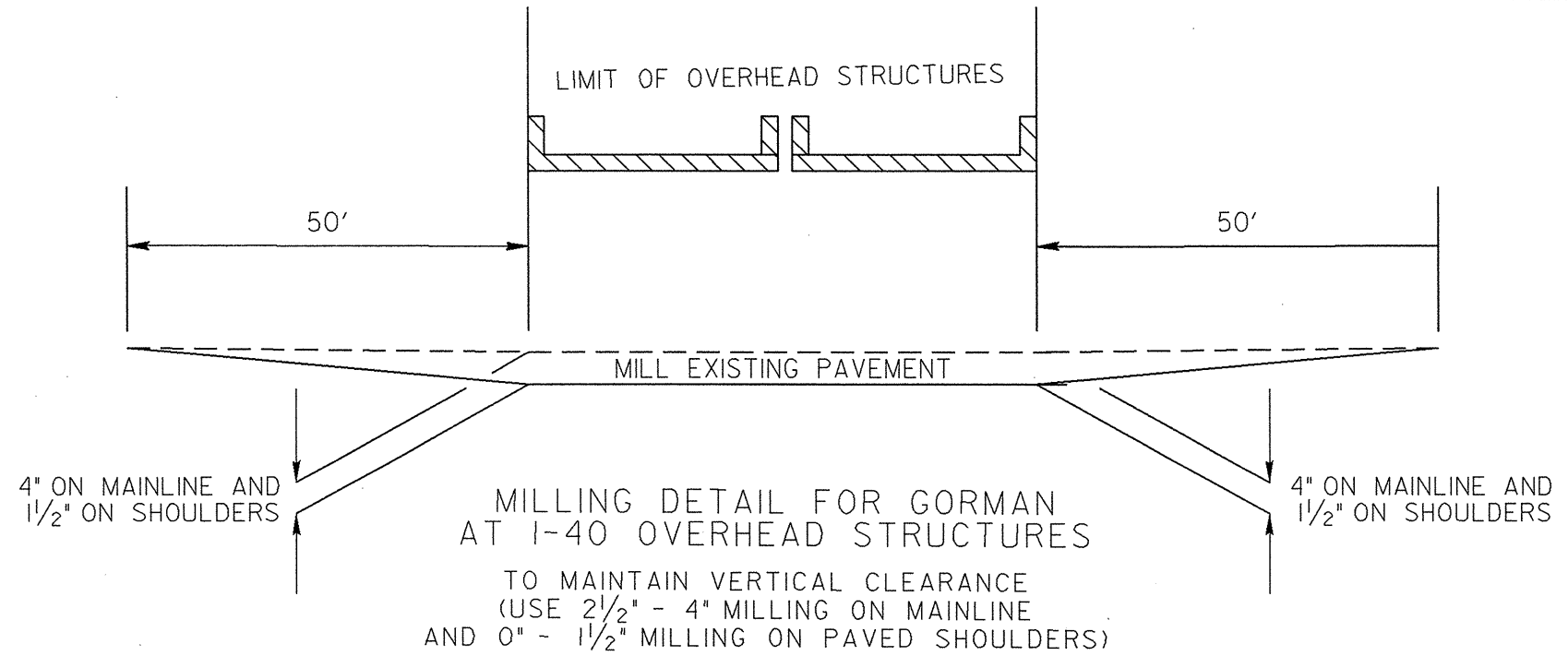

**IN AREA OF I-40 STRUCTURES ONLY TO MAINTAIN VERTICAL CLEARANCE (SEE DETAIL)

**IN AREA OF I-40 STRUCTURES ONLY TO MAINTAIN VERTICAL CLEARANCE (SEE DETAIL)

PAVEMENT SCHEDULE

C1	1½" ASPHALT CONCRETE SURFACE COURSE, TYPE S9.5B, AT AN AVERAGE RATE OF 168 LBS. PER SQ. YD.
C2	1¼" ASPHALT CONCRETE SURFACE COURSE, TYPE SF9.5A, AT AN AVERAGE RATE OF 137.5 LBS. PER SQ. YD.
D	2½" ASPHALT CONCRETE INTERMEDIATE COURSE, TYPE I19.0B, AT AN AVERAGE RATE OF 285 LBS. PER SQ. YD.
E	5.5" ASPHALT CONCRETE BASE COURSE, TYPE B25.0B, AT AN AVERAGE RATE OF 627 LBS. PER SQ. YD.
S	PROP. SHOULDER GRADING
U	EXISTING PAVEMENT
V1	1½" MILLING
V2	2½" MILLING
V3	2½" - 4" MILLING NEW ASPHALT TO BE PAVED BACK FLUSH
V4	0" - 1½" MILLING NEW ASPHALT TO BE PAVED BACK FLUSH

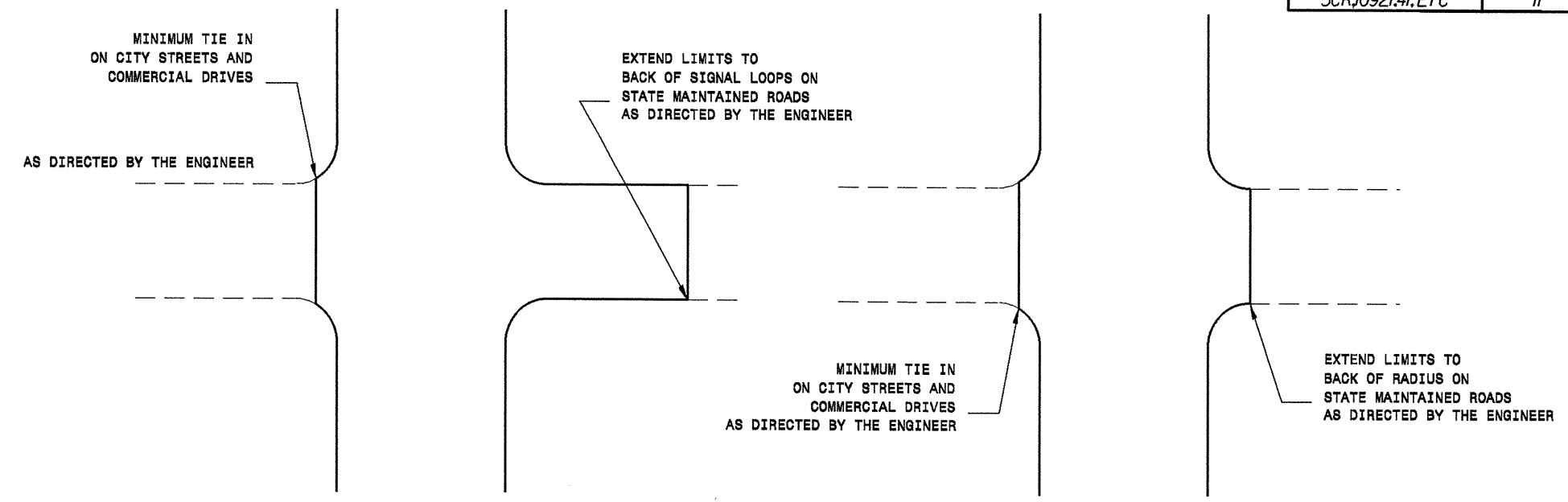

DETAIL OF PROJECT LIMITS AT SIGNALIZED Y LINES

DETAIL OF PROJECT LIMITS AT UNSIGNALIZED Y LINES

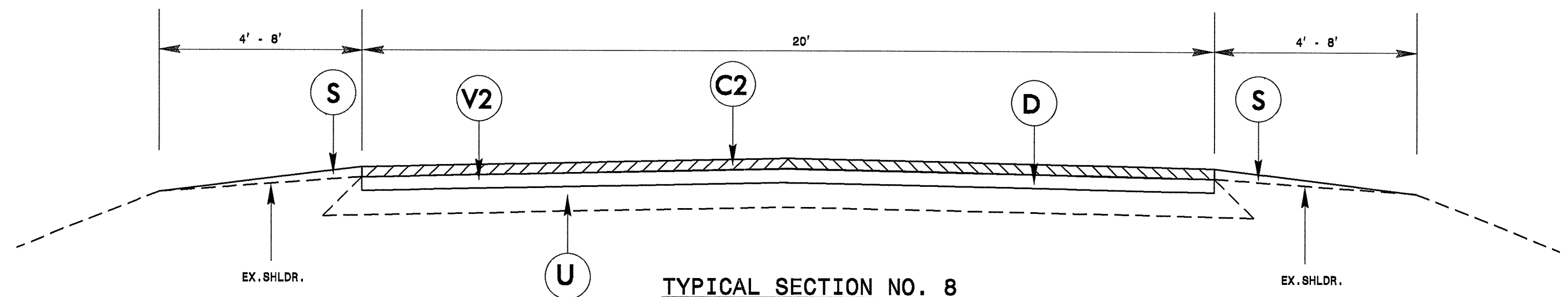

TYPICAL SECTION NO. 8

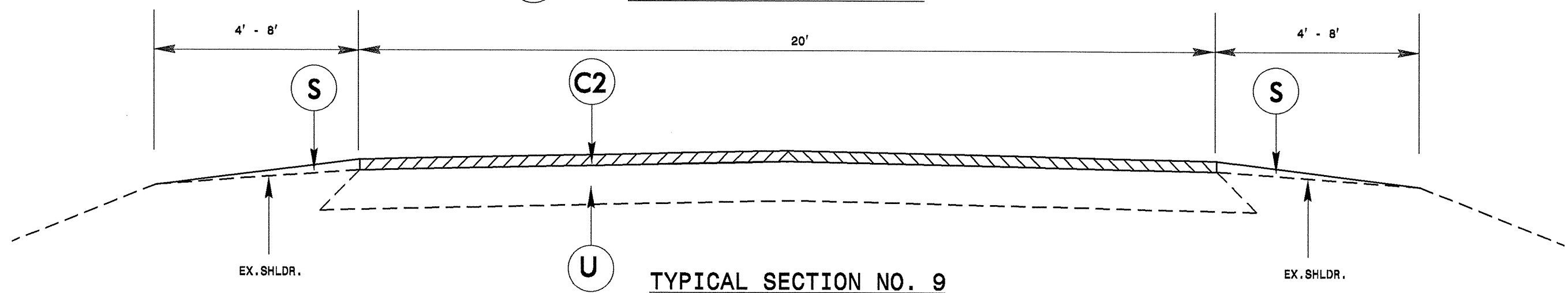

TYPICAL SECTION NO. 9

PAVEMENT SCHEDULE

C1	1½" ASPHALT CONCRETE SURFACE COURSE, TYPE S9.5B, AT AN AVERAGE RATE OF 168 LBS. PER SQ. YD.
C2	1¼" ASPHALT CONCRETE SURFACE COURSE, TYPE SF9.5A, AT AN AVERAGE RATE OF 137.5 LBS. PER SQ. YD.
D	2½" ASPHALT CONCRETE INTERMEDIATE COURSE, TYPE I19.0B, AT AN AVERAGE RATE OF 285 LBS. PER SQ. YD.
E	5.5" ASPHALT CONCRETE BASE COURSE, TYPE B25.0B, AT AN AVERAGE RATE OF 627 LBS. PER SQ. YD.
S	PROP. SHOULDER GRADING
U	EXISTING PAVEMENT
V1	1½" MILLING
V2	2½" MILLING
V3	2½" - 4" MILLING NEW ASPHALT TO BE PAVED BACK FLUSH
V4	0" - 1½" MILLING NEW ASPHALT TO BE PAVED BACK FLUSH

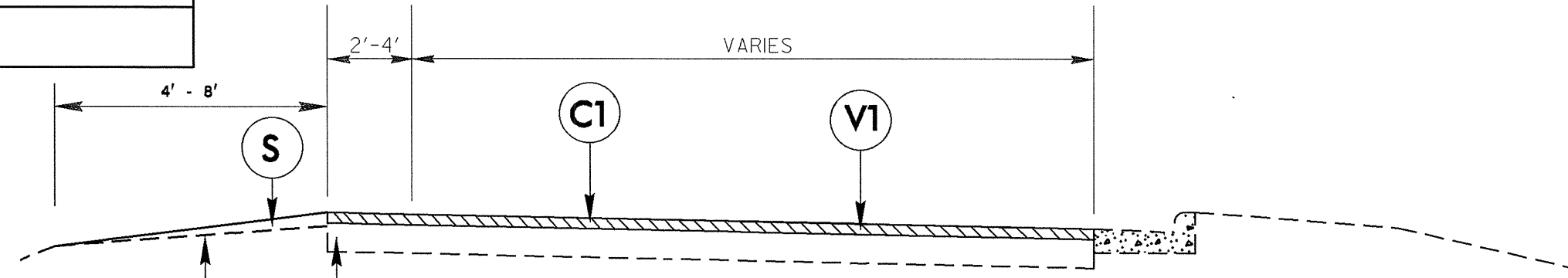

TYPICAL SECTION NO. 10

*CONTRACTOR SHALL USE THIS TYPICAL FOR THE LOOPS

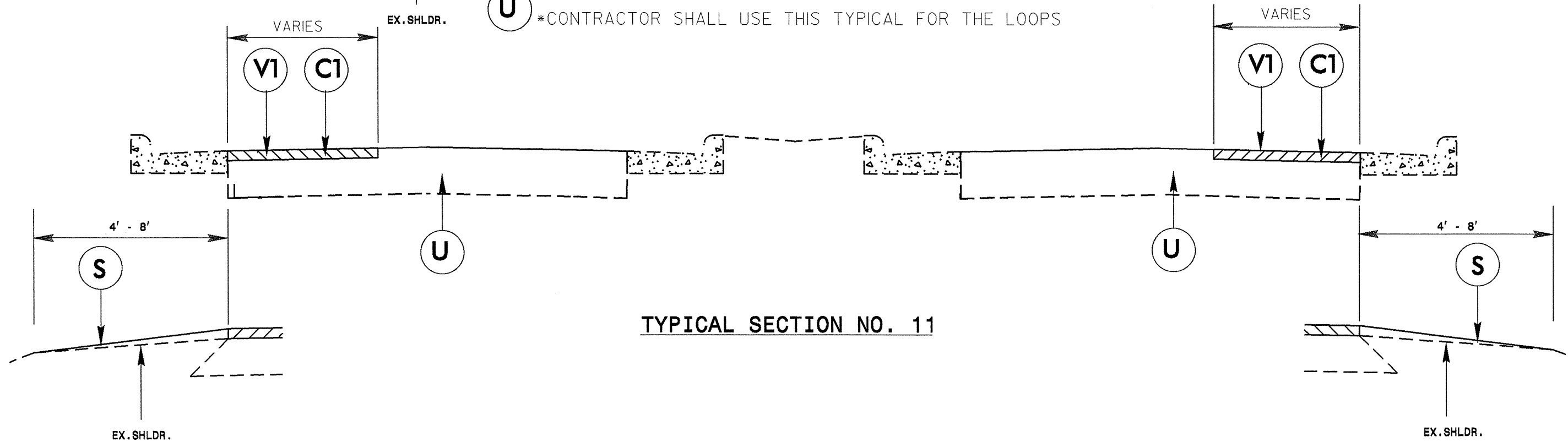

TYPICAL SECTION NO. 11

**DIVISION OF HIGHWAYS
STATE OF NORTH CAROLINA**

SOIL STABILIZATION TIMEFRAMES

<i>SITE DESCRIPTION</i>	<i>STABILIZATION TIME</i>	<i>TIMEFRAME EXCEPTIONS</i>
PERIMETER DIKES, SWALES, DITCHES AND SLOPES	7 DAYS	NONE
HIGH QUALITY WATER (HOW) ZONES	7 DAYS	NONE
SLOPES STEEPER THAN 3:1	7 DAYS	IF SLOPES ARE 10' OR LESS IN LENGTH AND ARE NOT STEEPER THAN 2:1, 14 DAYS ARE ALLOWED.
SLOPES 3:1 OR FLATTER	14 DAYS	7 DAYS FOR SLOPES GREATER THAN 50' IN LENGTH.
ALL OTHER AREAS WITH SLOPES FLATTER THAN 4:1	14 DAYS	NONE, EXCEPT FOR PERIMETERS AND HOW ZONES.

NOTES: Less than 5' - 10' undisturbed buffer from ROW, ditchline, water feature, or drainage inlet, add BMP.

BMP Options: Wattle, Silt Fence, or Hardened Aggregate.

EROSION CONTROL DETAIL

PROJECT REFERENCE NO.	SHEET NO.
SCR.10921.41, SCR.20921.41	14

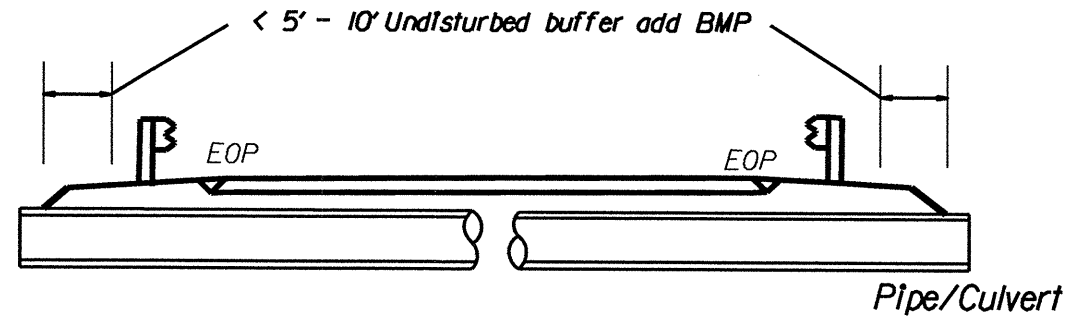

< 5' - 10' Undisturbed buffer from jurisdictional feature add BMP

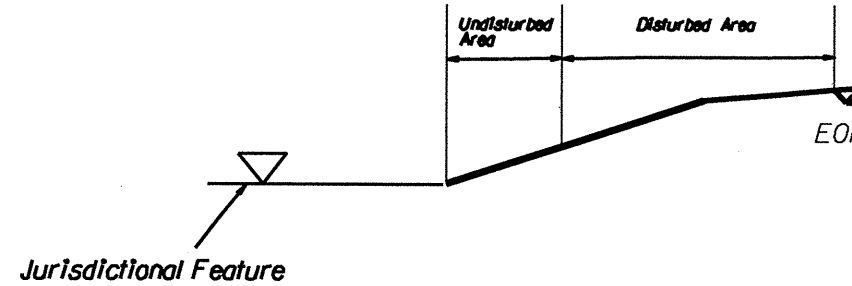

< 5' - 10' Undisturbed buffer from ditchline, add BMP

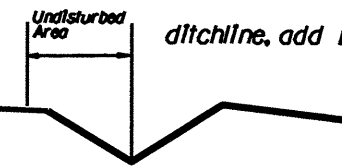

Use BMP's if shoulders and/or frontslopes and/or ditchline and/or backslopes are disturbed

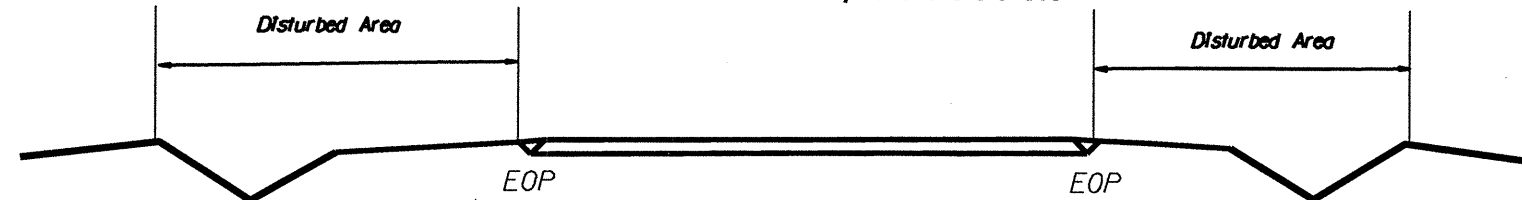

< 5' - 10' Undisturbed buffer from Inlet, add wattle

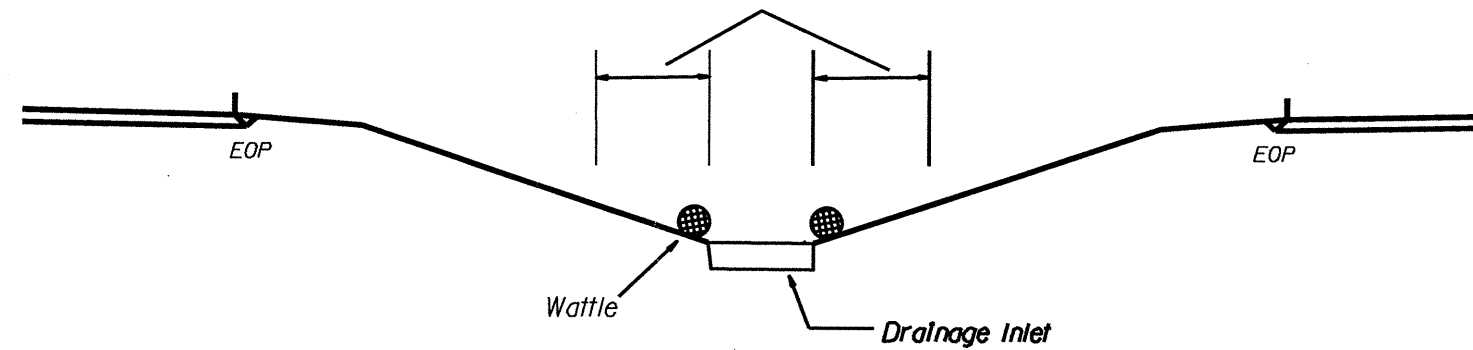

NOT TO SCALE

WATTLE DETAIL

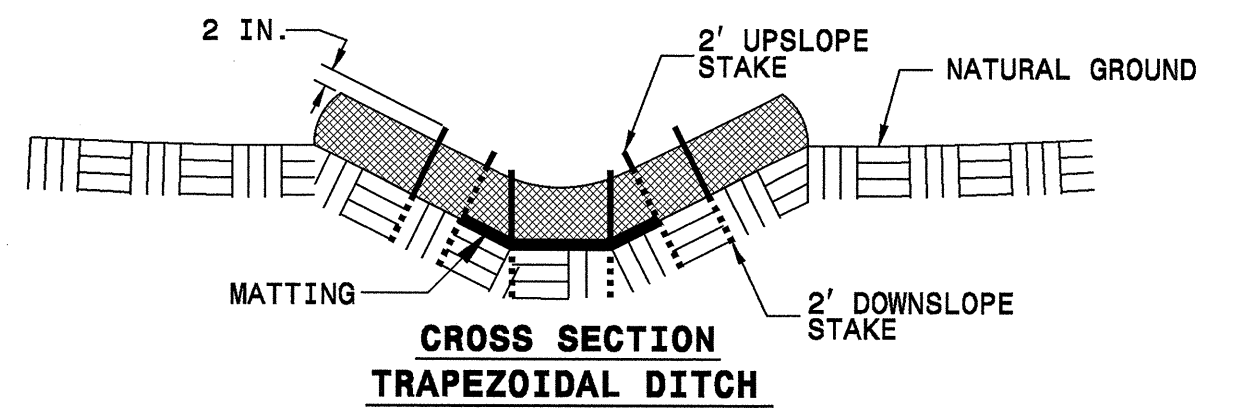
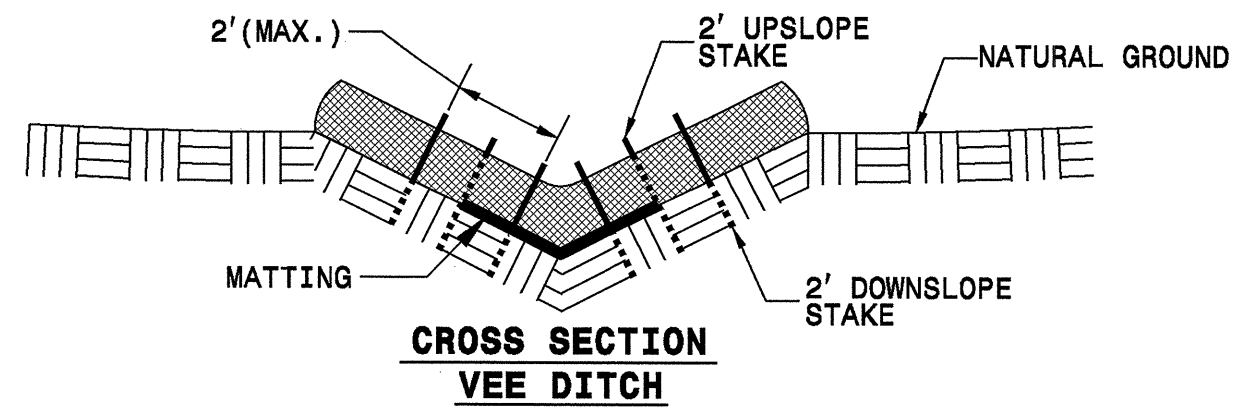
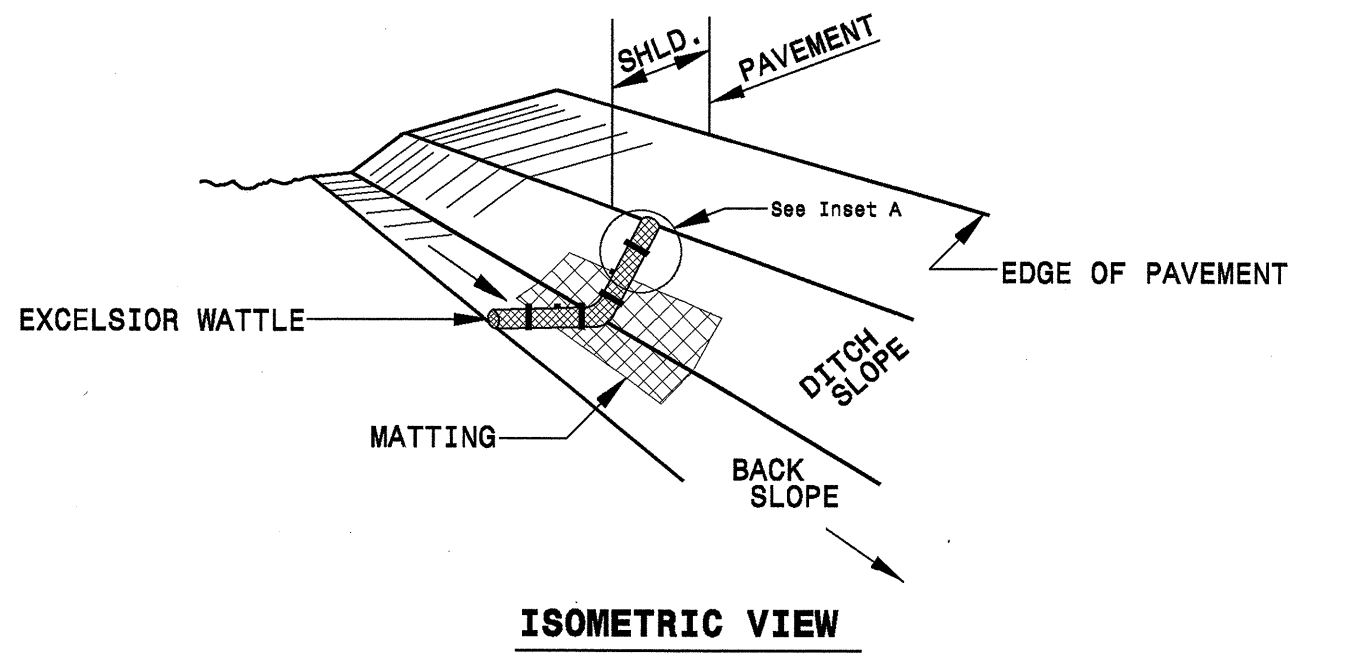

NOTES:

USE MINIMUM 12 IN. DIAMETER EXCELSIOR WATTLE.

USE 2 FT. WOODEN STAKES WITH A 2 IN. BY 2 IN. NOMINAL CROSS SECTION.

ONLY INSTALL WATTLE(S) TO A HEIGHT IN DITCH SO FLOW WILL NOT WASH AROUND WATTLE AND SCOUR DITCH SLOPES AND AS DIRECTED.

INSTALL A MINIMUM OF 2 UPSLOPE STAKES AND 4 DOWNSLOPE STAKES AT AN ANGLE TO WEDGE WATTLE TO BOTTOM OF DITCH.

PROVIDE STAPLES MADE OF 0.125 IN. DIAMETER STEEL WIRE FORMED INTO A U SHAPE NOT LESS THAN 12" IN LENGTH.

INSTALL STAPLES APPROXIMATELY EVERY 1 LINEAR FOOT ON BOTH SIDES OF WATTLE AND AT EACH END TO SECURE IT TO THE SOIL.

INSTALL MATTING IN ACCORDANCE WITH SECTION 1631 OF THE STANDARD SPECIFICATIONS.

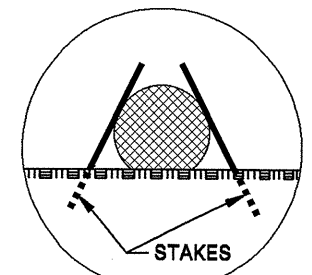

INSET A

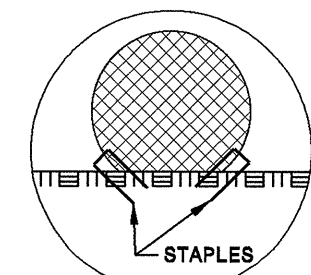

INSET B

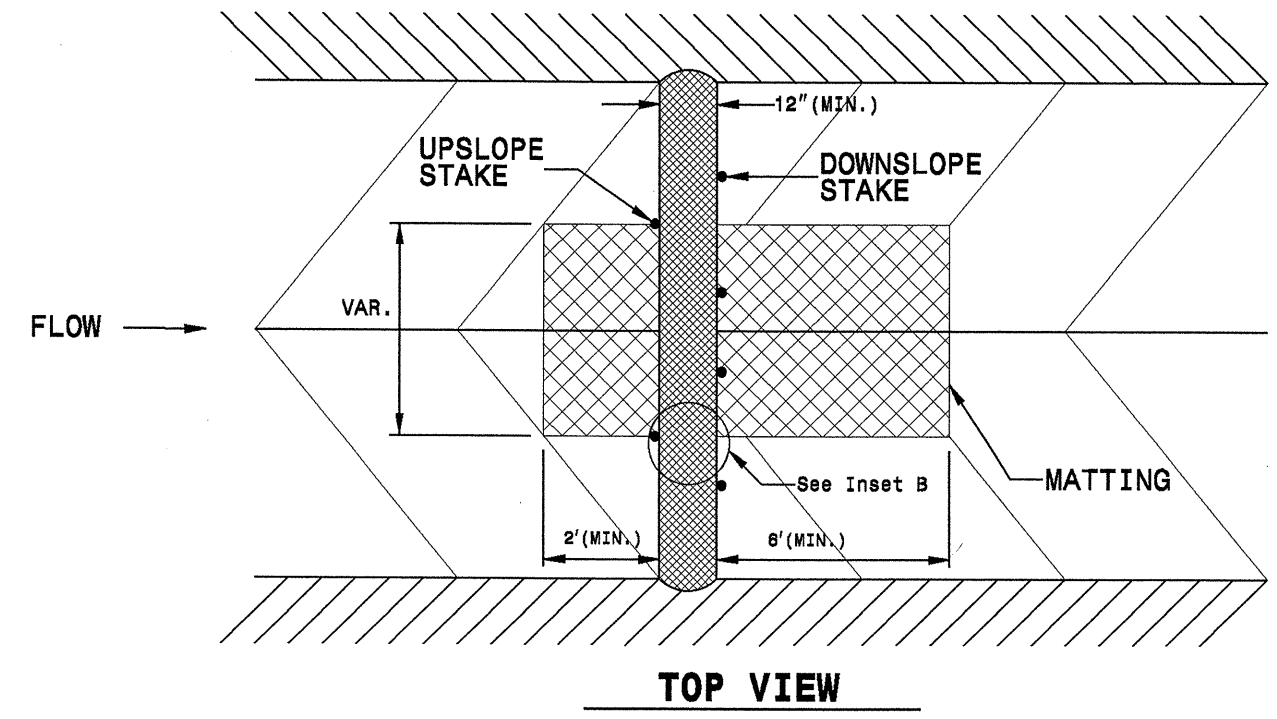

PROJECT NO.	SHEET NO.	TOTAL NO.
SCR.10921.41, SCR.20921.41	16	17

SUMMARY OF QUANTITIES

PROJECT NO	COUNTY	MAP NO	ROUTE	DESCRIPTION	TYP NO	FINAL SURFACE TESTING REQUIRED	LENGTH MI	WIDTH FT	BORROW CY	SHOULDER GRADING SMI	INCIDENTAL STONE BASE TONS	1 1/4" MILLING SY	2.5" MILLING SY	2.5" TO 4" MILLING SY	0" TO 1.5" MILLING SY	INCIDENTAL MILLING SY	BASE COURSE, B25.0B TONS	INTER-MEDIATE COURSE, I19.0B TONS	SURFACE COURSE, S9.5B TONS	SURFACE COURSE, SF9.5A TON	ASPHALT BINDER FOR PLANT MIX TON	PATCHING EXISTING PAVEMENT TONS	ADJUST MANHOLES EA	ADJUST METER OR VALVE BOX EA	PORTABLE LIGHTING LS	TEMPORARY SILT FENCE LF	WATTLE LF	SEED & MULCHING AC	INDUCTIVE LOOP LF		
5CR.10921.41	Wake	1A	US 401 - S DAWSON ST AND MCDOWELL ST	RAMPS AND MERGE LANES AT INTERSECTION WITH MLK BLVD	1, 10, 11	NO	0.142	12-26	124	1.24	73	17,841						1,649		99	75			0.50	90	230	0.90				
TOTAL FOR MAP NO. 1							0.142		124	1.24	73	17,841						1,649		99	75			0.50	90	230	0.90				
TOTAL FOR PROJ NO. 5CR.10921.41							0.142		124	1.24	73	17,841						1,649		99	75			0.50	90	230	0.90				
5CR.20921.41	Wake	1B	SR 1012 - WESTERN BLVD./MLK JR. BLVD.	EAST OF HUNT DR TO PERSON ST	2,6	NO	1.55	56-104	24	0.24	12	66,874						5,908		354	700	7	2	0.50	18	50	0.18	2,268			
TOTAL FOR MAP NO. 1							1.55		24	0.24	12	66,874							5,908		354	700	7	2	0.50	18	50	0.18	2,268		
5CR.20921.41	Wake	2	SR 1571 - GORMAN ST.	SR 1009 - TRYON RD TO SR 1321 - AVENT FERRY RD	3,7	NO	1.45	40-64	342	3.41	145		46,032	3,408	950	960		7,247	5,849	699	100	1			249	630	2.49	2,470			
TOTAL FOR MAP NO. 2							1.45		342	3.41	145			46,032	3,408	950	960		7,247	5,849	699	100	1			249	630	2.49	2,470		
5CR.20921.41	Wake	3	SR 1382 - OLDE SOUTH RD	SR 1381 - YATES MILL POND RD TO SR 1379 - PENNY RD	4	NO	1.06	24	213	2.12	106	13,091				775	940	1,461		129	400				154	390	1.54				
TOTAL FOR MAP NO. 3							1.06		213	2.12	106	13,091				775	940	1,461		129	400		129	400				154	390	1.54	
5CR.20921.41	Wake	4	SR 2538 - MECHANICAL BLVD	SR 2539 - YEARGAN RD TO W OF DYNAMIC DR	5	NO	0.71	20	141	1.41	71		9,003			208		1,369	842	116	50		5		102	260	1.03				
TOTAL FOR MAP NO. 4							0.71		141	1.41	71			9,003			208		1,369	842	116	50		5		102	260	1.03			
5CR.20921.41	Wake	5	SR 2539 - YEARGAN RD	SR 1004 - WEST GARNER RD TO US 70	5	NO	0.35	20	70	0.70	35		4,235			330		642	395	54	50		1		51	130	0.51	198			
TOTAL FOR MAP NO. 5							0.35		70	0.70	35			4,235			330		642	395	54	50		1		51	130	0.51	198		
5CR.20921.41	Wake	6	SR 2711 - BUFFALO RD	SR 2710 - AVERSBO RD TO BRIARHAVEN CT	8	NO	0.87	20	173	1.74	87		10,196			165		1,543		776	126	50		6		126	320	1.26			
TOTAL FOR MAP NO. 6							0.87		173	1.74	87			10,196			165		1,543		776	126	50		6		126	320	1.26		
5CR.20921.41	Wake	7	SR 2547 - WHITE OAK RD	SR 2707 - BRYAN RD TO N OF HEBRON CH RD	5	NO	0.95	22-24	188	1.90	94		13,235			122		2,019	1,242	171	50				136	340	1.38				
TOTAL FOR MAP NO. 7							0.95		188	1.90	94			13,235			122		2,019	1,242	171	50				136	340	1.38			
5CR.20921.41	Wake	8	SR 1007 - POOLE RD	SR 4108 - HICKORY HOLLOW LN TO SR 2551 - BARWELL RD	1	NO	0.95	24	161	1.61	81	16,979						1,575		95	150		5		117	300	1.17	210			
TOTAL FOR MAP NO. 8							0.95		161	1.61	81	16,979							1,575		95	150		5		117	300	1.17	210		
TOTAL FOR PROJ NO. 5CR.20921.41							8.38		1,410	14.11	680	96,944		82,701	3,408	950	2,671	940	12,820	17,272	1,213	1,773	1,650	9	21	0.50	1,024	2,600	10.27	5,146	
GRAND TOTAL							8.522		1,534	15.35	753	114,785		82,701	3,408	950	2,671	940	12,820	18,921	1,213	1,872	1,725	9	21	1.00	1,114	2,830	11.17	5,146	

PROJECT NO.	SHEET NO.	TOTAL NO.
SCR.10921.41, SCR.20921.41	17	17

THERMOPLASTIC AND PAINT QUANTITIES

PROJECT NO	COUNTY	MAP NO	ROUTE	DESCRIPTION	LENGTH	WIDTH	468500000-E		468600000-E		469500000-E		469700000-E		470500000-E		471000000-E		472100000-E					472610000-E		477000000-E		480000000-N					
							4" X 90 M YELLOW THERMO	4" X 90 M WHITE THERMO	4" X 120 M WHITE THERMO	4" X 120 M YELLOW THERMO	8" X 90 M WHITE THERMO	8" X 90 M YELLOW THERMO	8" X 120 M WHITE THERMO	16" X 120 M WHITE THERMO	24" X 120 M WHITE THERMO	THERMO MSG ONLY 120 M	THERMO MSG LANE 120 M	THERMO MSG BUS 120 M	THERMO MSG ENDS 120 M	THERMO MSG 1500 FT 120 M	THERMO RXR 120 M	THERMO LT ARROW 90 M	THERMO RT ARROW 90 M	THERMO MERGE ARROW 90 M	THERMO STR ARROW 90 M	THERMO STR & RT ARROW 90 M	THERMO STR & LT ARROW 90 M	HEATED-IN-PLACE THERMO SYMBOL 90 M (HELMETED BICYCLIST)	HEATED-IN-PLACE THERMO SYMBOL 90 M (BIKE STR ARROW)	4" YELLOW COLD APPLIED PLASTIC, TYPE III	4" WHITE COLD APPLIED PLASTIC, TYPE III	COLD APPLIED MSG ONLY, TYPE III	
SCR.10921.41	Wake	1	US 401 - S DAWSON ST AND MCDOWELL ST	RAMP AND MERGE LANES AT INTERSECTION WITH MLK BLVD	0.142	24	3,680	4,360	780		2,180				102	8				6	7	6											
TOTAL FOR MAP NO. 1							0.142	3,680	4,360	780	2,180			102	8				6	7	6												
TOTAL FOR PROJ NO. SCR.10921.41							0.142	3,680	4,360	780	2,180			102	8				6	7	6												
GRAND TOTAL							8.522	9,102	78,030	15,833	72,145	4,415	178	1,227	150	1,882	40	12	6	4	6	6	58	35	12	70	11	5	30	30	810	1,170	4

PROJECT NO	COUNTY	MAP NO	ROUTE	DESCRIPTION	LENGTH	WIDTH	489500000-N		481000000-E		482000000-E		483000000-E		483500000-E		484000000-N					485000000-E		490000000-N								
							COLD APPLIED PLASTIC RT ARROW, TYPE III	COLD APPLIED PLASTIC MERGE ARROW, TYPE III	4" WHITE PAINT	4" YELLOW PAINT	8" WHITE PAINT	8" YELLOW PAINT	16" WHITE PAINT	24" WHITE PAINT	PAINT MSG ONLY	PAINT MSG LANE	PAINT MSG BUS	PAINT MSG ENDS	PAINT MSG 1500 FT	PAINT MSG RXR	PAINT LT ARROW	PAINT RT ARROW	PAINT STR ARROW	PAINT STR & RT ARROW	PAINT MERGE ARROW	PAINT STR & LT ARROW	4" LINE REMOVAL	REML OF PVMT MRKG SYMBOLS & CHARACTERS	CRYSTAL & RED MARKERS	YELLOW & YELLOW MARKERS		
SCR.10921.41	Wake	1	US 401 - S DAWSON ST AND MCDOWELL ST	RAMP AND MERGE LANES AT INTERSECTION WITH MLK BLVD	0.142	24																										
TOTAL FOR MAP NO. 1							0.142																									
TOTAL FOR PROJ NO. SCR.10921.41							0.142																									
GRAND TOTAL							8.522	3	1	61,548	48,981	3,047	148	150	1,692	32	12	6	4	6	6	52	22	70	11	6	5	1,980	8	856	556	

High Speed Detection [≥40 mph (64 km/hr)]

Low Speed Detection [≤35 mph (56 km/hr)]

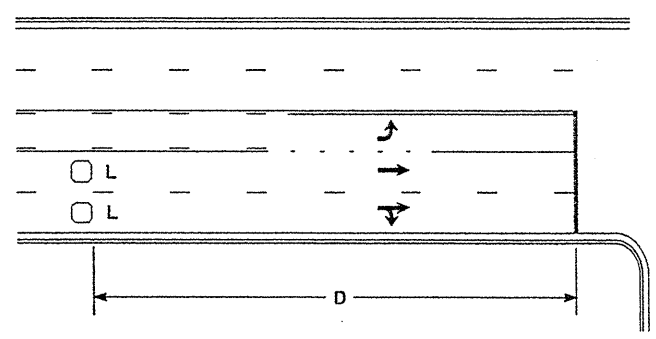

OR

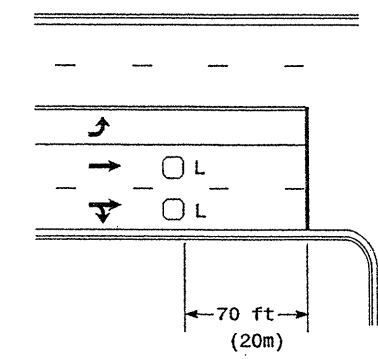
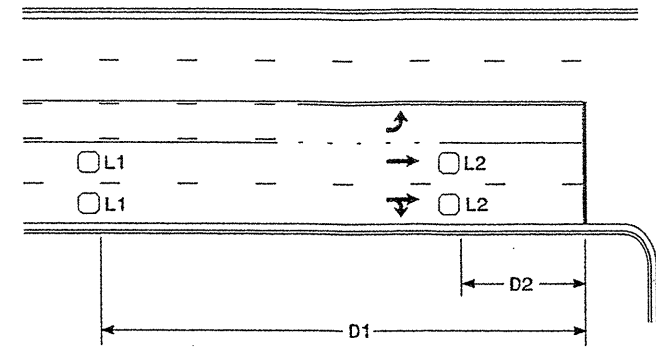

OR

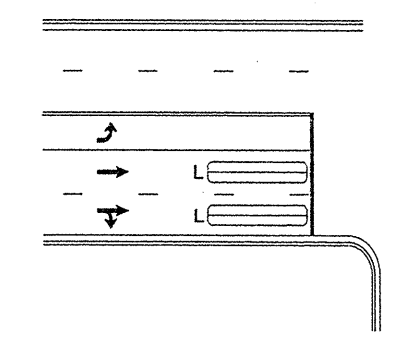

Speed Limit mph (km/hr)	D ft (m)
40 (64)	250 (75)
45 (72)	300 (90)
50 (80)	355 (110)
55 (88)	420 (130)

L = 6ft X 6ft (1.8m X 1.8m)
Wired in series for TS1
Controllers
Wired separately for TS2,
170, and 2070L Controllers

Speed Limit mph (km/hr)	D1 ft (m)	D2 ft (m)
40 (64)	250 (75)	80 (25)
45 (72)	300 (90)	90 (27)
50 (80)	355 (110)	100 (30)
55 (88)	420 (130)	110 (35)

L1 = 6ft X 6ft
(1.8m X 1.8m)
Wired in series
L2 = 6ft X 6ft
(1.8m X 1.8m)
Wired in series

L = 6ft X 6ft (1.8m X 1.8m)
Wired in series

L = 6ft X 40ft (1.8m X 12.0m)
Quadrupole loop, wired separately

Volume Density Operation

"Stretch" Operation

Left Turn Lane Detection

Right Turn Lane Detection

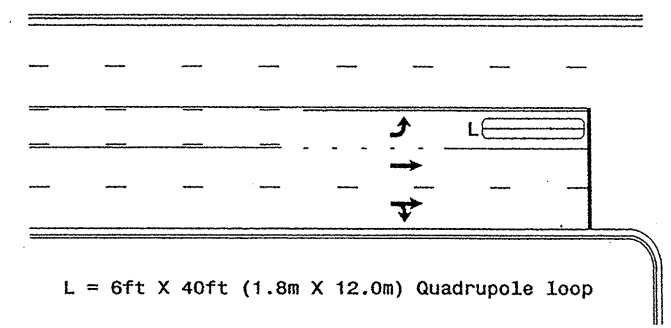

L = 6ft X 40ft (1.8m X 12.0m) Quadrupole loop

Presence Loop Detection

OR

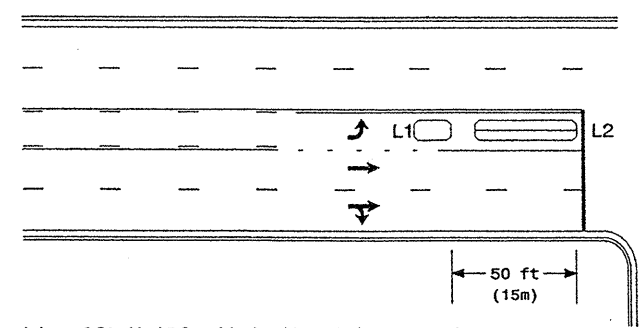

L1 = 6ft X 15ft (1.8m X 4.6m) Queue detector
L2 = 6ft X 40ft (1.8m X 12.0m) Quadrupole loop

Queue Loop Detection

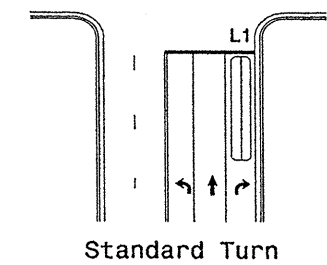

Standard Turn

L1 = 6ft X 40ft (1.8m X 12.0m) Quadrupole loop
L2 = 6ft X 6ft (1.8m X 1.8m) [Minimum] Presence loop
Wired separately
L3 = 6ft X 20ft (1.8m X 6.0m) Quadrupole loop
Wired in series

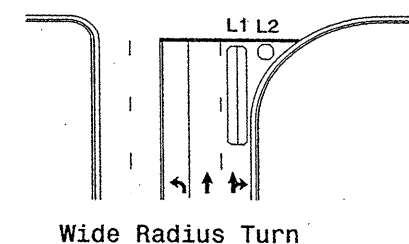

Wide Radius Turn

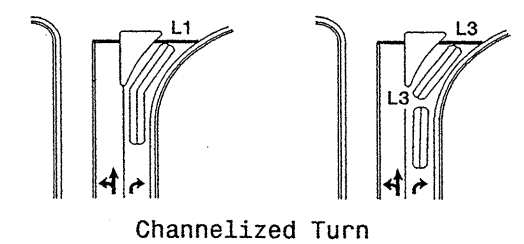

Channelized Turn

Side Street Detection

Presence Loop Placement at Stop Lines

Recommended Number of Turns

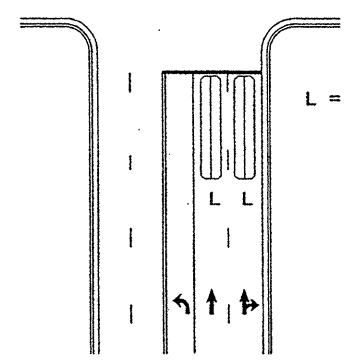

L = 6ft X 40ft (1.8m X 12.0m)
Quadrupole loop
Wired to separate
detectors/channels

Side Street Detection

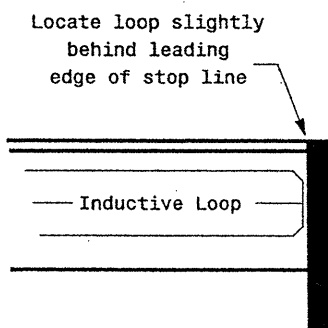

Locate loop slightly
behind leading
edge of stop line

Inductive Loop

Note:
Loop may be located in advance
of stop line when stop line is
greater than 15' (4.5m) from edge
of intersecting roadway; or, when
loop detects a permissive or
protected/permissive left turn.

Single 6' X 6' (1.8m X 1.8m)
loop (wired separately):

Length of Lead-in ft (m)	Number of Turns
< 250 (75)	3
250-375 (75-115)	4
375-525 (115-160)	5
> 525 (160)	6

Quadrupole loops: Use 2-4-2 turns
6' X 15' (1.8m X 4.6m) Loops:
Lead-in < 150' (45 m), use 2 turns
Lead-in > 150' (45 m), use 3 turns

19-DEC-2006 14:29 5:41:15 signal\sig1\turn_innemiace\loop\typical\2006.dgn p.l.alexander

Typical Loop Locations

PLAN DATE: June 2006	REVIEWED BY:
PREPARED BY: P. L. Alexander	REVIEWED BY:
SCALE: N/A	INITIALS: AC
DATE: 12/19/06	DATE:

SIGNATURE: P. L. Alexander DATE: 12/19/06 SIG. INVENTORY NO.: