

**STATE OF NORTH CAROLINA
DEPARTMENT OF TRANSPORTATION**

TIP NO. I - 4413	SHEET NO. SIGN - 1A
APPROVED: <i>[Signature]</i>	
DATE: 3/29/12	
SEAL	

**SIGNING PLANS
ROBESON COUNTY**

LOCATION: BRIDGE NO. 36 ON US 301 (FAYETTEVILLE ROAD) OVER I-95 (EXIT 23)

T.I.P.: I-4413

CONTRACT: C202847

PAY ITEM NOTES

1	DISPOSAL OF SIGN SYSTEM, U-CHANNEL
2	DISPOSAL OF SIGN SYSTEM, WOOD
3	DISPOSAL OF SIGN SYSTEM, STEEL BEAM
4	SIGN ERECTION, RELOCATE SIGN TYPE A (GROUND MOUNTED) * WHEN VERIFYING "S" DROPS ALSO VERIFY EXISTING SIGN DIMENSIONS
5	SIGN ERECTION, RELOCATE SIGN TYPE E
6	DISPOSAL OF SUPPORT, STEEL BEAM
7	DISPOSAL OF SUPPORT, U-CHANNEL

PROJECT NOTE

- LUMBERTON TOWN FORCES TO REMOVE SIGN AND REPLACE AS NEEDED
- LOCATE AND REPLACE MILE MARKER IN EXISTING LOCATION

GENERAL NOTES

- SIGNS FURNISHED BY STATE
- ALL TYPE 'D' SIGNS SHALL BE MOUNTED ON TWO U-CHANNEL POSTS UNLESS OTHERWISE INDICATED ON THE PLANS.
- IF REMOVAL OR RELOCATION OF SIGNS ON PRIVATE STREET (NON-STATE MAINTAINED) IS REQUIRED DUE TO CONSTRUCTION, THE CONTRACTOR SHALL INFORM THE ENGINEER. THE WORK WILL BE COMPLETED BY OTHERS.
- WHEN NOT STATIONED OR DIMENSIONED ON PLANS, ALL 'E' AND 'F' SIGNS SHALL BE FIELD LOCATED BY THE ENGINEER
- ALL EXISTING SIGNS ON "U" CHANNEL POST WITHIN THE PROJECT LIMITS SHALL BE REMOVED AND DISPOSED OF UNLESS OTHERWISE NOTED ON PLANS.
- WHEN EXISTING SIGNS ARE REMOVED AND INSTALLED ON NEW SUPPORTS, THE RE-ERECTION SHALL IMMEDIATELY FOLLOW THE REMOVAL.
- THE BACKGROUND FOR TYPE E & F SIGNS SHALL BE TYPE C REFLECTIVE SHEETING.
- DO NOT BEGIN FABRICATION FOR TYPES A & B SIGNS MOUNTED ON OVERHEAD STRUCTURES OR STEEL SUPPORTS UNTIL "S" DIMENSIONS HAVE BEEN FIELD VERIFIED.
- SEE ROADWAY PLANS FOR GUARD/GUIDE RAIL DETAILS.

PLAN PREPARED BY: N.C.D.O.T. SIGNING AND DELINEATION UNIT

AYMAN I. ALQUDWAH, P.E.	SIGNING & DELINEATION REGIONAL ENGINEER
ERIC WARD	SIGNING & DELINEATION DESIGN ENGINEER

SUMMARY OF QUANTITIES

ITEM NO.	DESC. NO.	SECT. NO.	ITEM DESCRIPTION	QUANTITY	UNIT
4057000000		SP	OVERHEAD FOOTING	60	C.Y.
4048000000		902	REINFORCED CONCRETE SIGN FOUNDATION	27	C.Y.
4054000000		902	PLAIN CONCRETE SIGN FOUNDATION	1	C.Y.
4060000000		903	SUPPORTS, BREAKAWAY STEEL BEAM	21,210	LB.
4072000000		903	SUPPORTS, 3 LB U-CHANNEL	1,507	L.F.
4078000000		903	SUPPORTS, 2 LB STEEL U-CHANNEL	4	EA.
4082100000		SP	SUPPORTS, OVERHEAD SIGN STRUCTURE AT STATION -L- 15+50	1	LS
4082100000		SP	SUPPORTS, OVERHEAD SIGN STRUCTURE AT STATION -L- 28+45	1	LS
4082100000		SP	SUPPORTS, OVERHEAD SIGN STRUCTURE AT STATION -RP D- 19+57	1	LS
4082100000		SP	SUPPORTS, OVERHEAD SIGN STRUCTURE AT STATION -RP B- 19+50	1	LS
4096000000		904	SIGN ERECTION, TYPE D	2	EA.
4102000000		904	SIGN ERECTION, TYPE E	69	EA.
4108000000		904	SIGN ERECTION, TYPE F	7	EA.
4110000000		904	SIGN ERECTION, TYPE A (GROUND MOUNTED)	14	EA.
4110000000		904	SIGN ERECTION, TYPE B (GROUND MOUNTED)	8	EA.
4114000000		904	SIGN ERECTION, MILEMARKERS	4	EA.
4116100000		904	SIGN ERECTION, RELOCATE SIGN TYPE E	2	EA.
4116100000		904	SIGN ERECTION, RELOCATE SIGN TYPE A (GROUND MOUNTED)	7	EA.
4138000000		907	DISPOSAL OF SUPPORT, STEEL BEAM	7	EA.
4152000000		907	DISPOSAL OF SIGN SYSTEM, STEEL BEAM	15	EA.
4155000000		907	DISPOSAL OF SIGN SYSTEM, U-CHANNEL	49	EA.
4158000000		907	DISPOSAL OF SIGN SYSTEM, WOOD	1	EA.
4192000000		907	DISPOSAL OF SUPPORT, U-CHANNEL	2	EA.

ROADWAY STANDARD DRAWING

THE FOLLOWING ROADWAY STANDARDS AS APPEAR IN "ROADWAY STANDARD DRAWINGS" - PROJECT SERVICES UNIT - N.C. DEPARTMENT OF TRANSPORTATION - RALEIGH, N.C., DATED JANUARY 2012 ARE APPLICABLE TO THIS PROJECT AND BY REFERENCE HEREBY ARE CONSIDERED A PART OF THESE PLANS:

STD. NO.	TITLE
901.10	TYPE 'A' SIGNS
901.20	TYPE 'B' SIGNS
901.50	ARROWS AND SHIELDS
901.70	SIGN STRINGERS AND SUPPORT SPACING
901.80	SIGN MOUNTING DETAILS - FOR TYPE A AND TYPE B SIGNS
903.10	GROUND MOUNTED SIGN SUPPORTS (SHEETS 1 OF 1 & 3 OF 3 ONLY)
904.10	ORIENTATION OF GROUND MOUNTED SIGNS
904.20	SECONDARY SIGN MOUNTING
904.40	MILEPOST AND PLACEMENT
904.50	MOUNTING OF TYPE 'D', 'E' AND 'F' SIGNS ON 'U' CHANNEL POSTS

INDEX

SHEET NO.	DESCRIPTION
SIGN - 1A	TITLE SHEET - SUMMARY OF QUANTITIES, INDEX ROADWAY STANDARD DRAWINGS, & NOTES
SIGN - 1B	REVISED GROUND MOUNTED SIGN SUPPORTS SHEET 2 OF 3
SIGN - 2A - 2E	SUPPORT CHART, OVERHEAD STRUCTURE LINE DRAWINGS
SIGN - 3A - 3I	SIGN DESIGN, "E" AND "F" SHEETS
SIGN - 4 - 12	SIGNING DETAIL SHEETS

27-MAR-2012 09:28 P:\TIP\Projects\I-4413\I-4413-1\of\c\Signing\CADD\Signing Layout Plans\I-4413_sgn_psh1.dgn ericward AT 12/27/05

TIP NO.	SHEET NO.
I - 4413	SIGN - 1B
APPROVED: <i>[Signature]</i>	
DATE: 3/29/12	
SEAL	
	

STATE OF NORTH CAROLINA
 DEPT. OF TRANSPORTATION
 DIVISION OF HIGHWAYS
 RALEIGH, N.C.

BEAM SHAPE	SLIP BASE PLATE DATA							KEEPER PLATE DATA							HINGE CONNECTION DATA							BREAK AWAY SUPPORT WEIGHT CONSTANT LBS.				
	BOLT SIZE	A ₁	B ₁	C ₁	D ₁	E ₁	T ₁	R ₁	A ₂	B ₂	C ₂	D ₂	E ₂	R ₂	T ₂	BOLT SIZE	F	G	H	I	J		K	L	R ₃	T ₃
S3X5.7	1/2"DIA. X 3"	7"	4"	1"	3/4"	2 1/2"	1"	9/32"	7"	4"	1"	3/4"	2 1/2"	9/32"	28 GAUGE	1/2"DIA. X 1 1/4"	2 1/4"	3 1/2"	4"	1 1/2"	1"	1 1/2"	2"	9/32"	3/8"	18
S4X7.7	1/2"DIA. X 3"	8"	4"	1"	3/4"	2 1/2"	1"	9/32"	8"	4"	1"	3/4"	2 1/2"	9/32"	28 GAUGE	1/2"DIA. X 1 1/4"	2 5/8"	3 1/2"	4"	1 1/2"	1"	1 1/2"	2"	9/32"	3/8"	20
W6X9	1/2"DIA. X 3"	10"	5"	1"	3/4"	3 1/2"	1"	9/32"	10"	5"	1"	3/4"	3 1/2"	9/32"	28 GAUGE	1/2"DIA. X 1 1/4"	4"	3 1/2"	4"	3/4"	1"	1 1/2"	2"	9/32"	3/8"	32
W6X12	5/8"DIA. X 3 3/4"	11"	5"	1 1/4"	7/8"	3 1/4"	1 1/4"	11/32"	11"	5"	1 1/4"	7/8"	3 1/4"	11/32"	28 GAUGE	5/8"DIA. X 2 1/4"	4"	4"	4 1/2"	3/4"	1 1/8"	5/8"	2 1/4"	11/32"	3/8"	39
W6X16	5/8"DIA. X 3 3/4"	12"	6"	1 1/4"	7/8"	4 1/4"	1 1/2"	11/32"	12"	6"	1 1/4"	7/8"	4 1/4"	11/32"	28 GAUGE	5/8"DIA. X 2 1/2"	4"	4"	4 1/2"	3/4"	1 1/8"	5/8"	2 1/4"	11/32"	1/2"	47
W8X18	5/8"DIA. X 4 1/4"	13 1/2"	6 1/2"	1 1/4"	7/8"	4 3/4"	1 1/2"	11/32"	13 1/2"	6 1/2"	1 1/4"	7/8"	4 3/4"	11/32"	28 GAUGE	5/8"DIA. X 2 1/2"	5 1/4"	4"	4 1/2"	1"	1 1/8"	5/8"	2 1/4"	11/32"	1/2"	70
W8X21	3/4"DIA. X 4 1/4"	14"	7"	1 1/2"	1"	5"	1 1/2"	13/32"	14"	7"	1 1/2"	1"	5"	13/32"	28 GAUGE	3/4"DIA. X 2 3/4"	5 1/4"	6"	7"	1"	1 3/4"	3/4"	3 1/2"	13/32"	1/2"	73
W10X22	3/4"DIA. X 4 1/4"	16"	8"	1 1/2"	1"	6"	1 1/2"	13/32"	16"	8"	1 1/2"	1"	6"	13/32"	28 GAUGE	3/4"DIA. X 2 3/4"	5 3/4"	6"	7"	1"	1 3/4"	3/4"	3 1/2"	13/32"	1/2"	119
W10X26	3/4"DIA. X 4 3/4"	16 1/2"	8"	1 1/2"	1"	6"	1 3/4"	13/32"	16 1/2"	8"	1 1/2"	1"	6"	13/32"	28 GAUGE	3/4"DIA. X 2 3/4"	5 3/4"	6"	7"	1"	1 3/4"	3/4"	3 1/2"	13/32"	5/8"	140
W12X26	3/4"DIA. X 4 3/4"	18 1/2"	9"	1 1/2"	1"	7"	1 3/4"	13/32"	18 1/2"	9"	1 1/2"	1"	7"	13/32"	28 GAUGE	3/4"DIA. X 2 3/4"	6 1/2"	6"	7"	1"	1 3/4"	3/4"	3 1/2"	13/32"	5/8"	176
W14X30	1"DIA. X 5"	22"	9"	2"	1 1/2"	6"	2"	17/32"	22"	9"	2"	1 1/2"	6"	17/32"	28 GAUGE	1"DIA. X 3"	6 3/4"	7"	8"	1 1/4"	2"	1"	4"	17/32"	5/8"	205
W16X31	1"DIA. X 5"	24"	9"	2"	1 1/2"	6"	2"	17/32"	24"	9"	2"	1 1/2"	6"	17/32"	28 GAUGE	1"DIA. X 3 1/4"	5 1/2"	7"	8"	1 1/4"	2"	1"	4"	17/32"	3/4"	223
W18X35	1"DIA. X 5"	25"	9"	2"	1 1/2"	6"	2"	17/32"	25"	9"	2"	1 1/2"	6"	17/32"	28 GAUGE	1"DIA. X 3 1/4"	6"	7"	8"	1 1/4"	2"	1"	4"	17/32"	3/4"	243
W18X40	1"DIA. X 5 1/2"	26"	9"	2"	1 1/2"	6"	2 1/4"	17/32"	26"	9"	2"	1 1/2"	6"	17/32"	28 GAUGE	1"DIA. X 3 3/4"	6"	7"	8"	1 1/4"	2"	1"	4"	17/32"	7/8"	278
W21X44	1"DIA. X 5 1/2"	29"	9"	2"	1 1/2"	6"	2 1/2"	17/32"	29"	9"	2"	1 1/2"	6"	17/32"	28 GAUGE	1"DIA. X 3 3/4"	6 1/2"	7"	8"	1 1/4"	2"	1"	4"	17/32"	7/8"	310

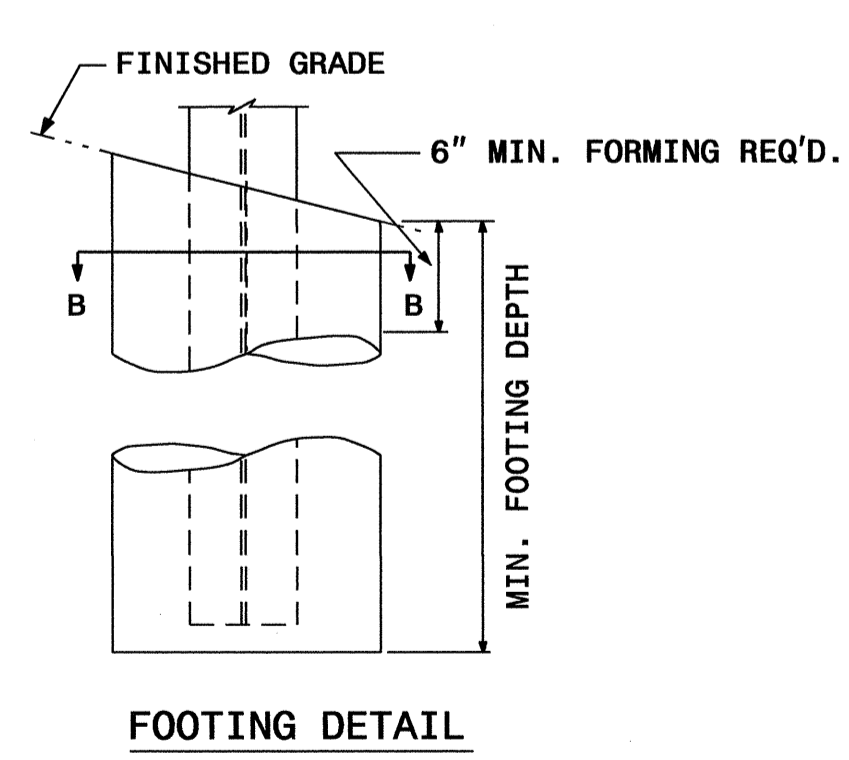
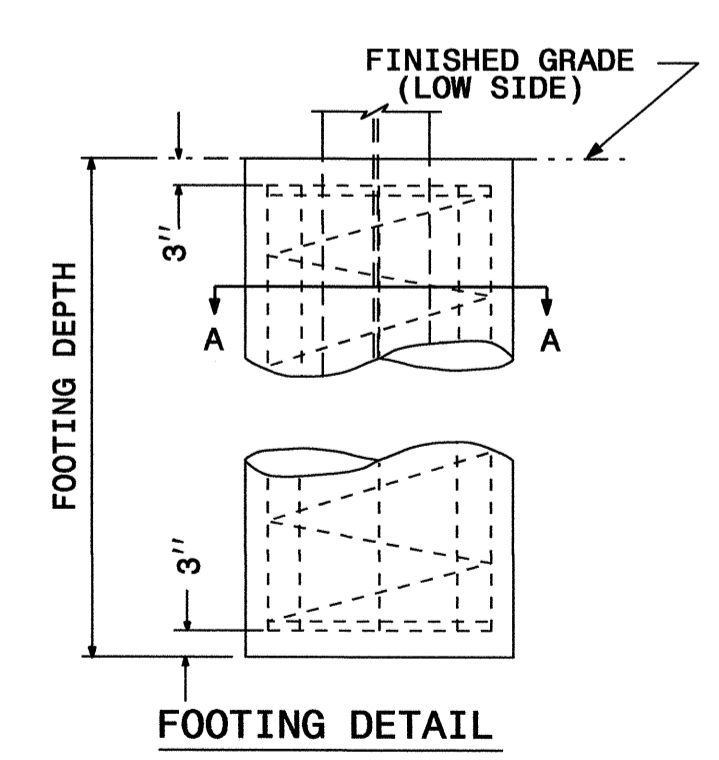
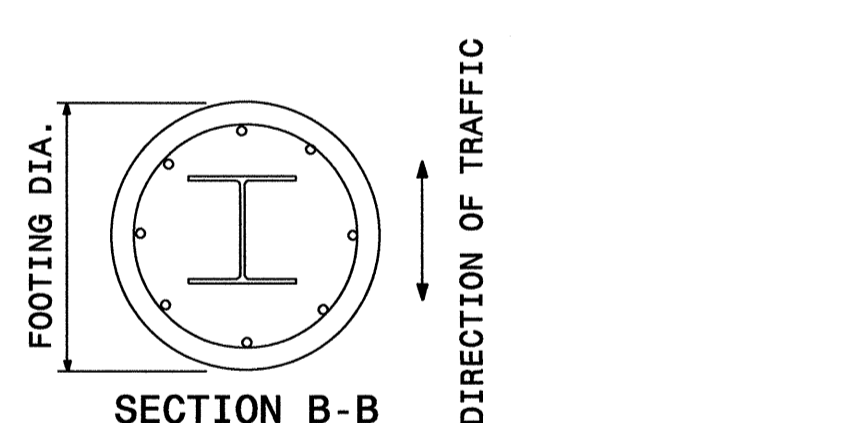
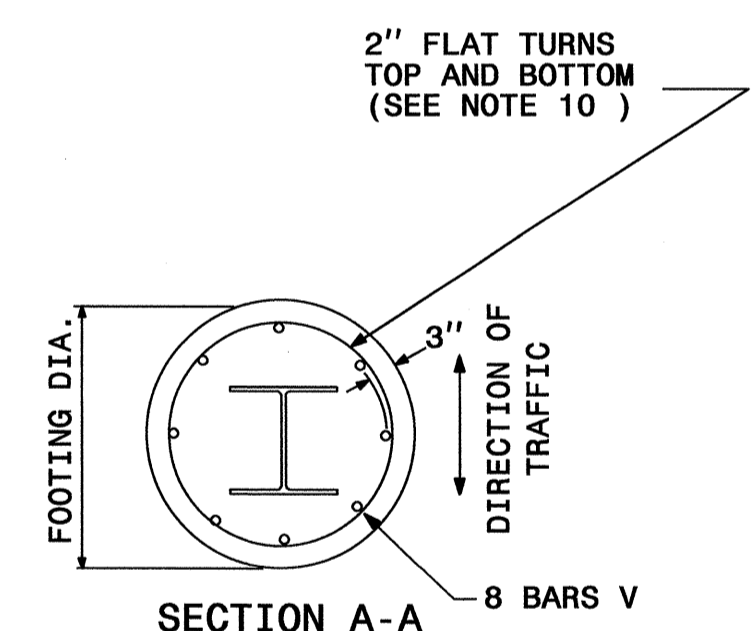

FOUNDATION DATA *		
FOOTING DIAMETER	REINFORCEMENT	SPIRAL BAR
1' 6"	8 # 6 BARS	#3 BAR, 6" PITCH
2'	8 # 7 BARS	#3 BAR, 6" PITCH
2' 6"	8 # 9 BARS	#3 BAR, 6" PITCH
3'	8 # 11 BARS	#3 BAR, 6" PITCH
3' 6"	8 # 12 BARS	#3 BAR, 6" PITCH
4'	8 # 14 BARS	#3 BAR, 6" PITCH

* FOUNDATION DIMENSIONS ARE SHOWN IN PLANS

STATE OF NORTH CAROLINA
 DEPT. OF TRANSPORTATION
 DIVISION OF HIGHWAYS
 RALEIGH, N.C.

ENGLISH DETAIL DRAWING FOR
GROUND MOUNTED SIGN SUPPORTS

SHEET 2 OF 3
903D10

SHEET 2 OF 3
903D10

**REVISED SIGNING
 ROADWAY STANDARD DRAWING**



SIGN NO.	SIGN TYPE	SIGN SIZE (in.)		ROADWAY STATION	NO. OF SUP.	BEAM SECTION	SUPPORT TYPE BA or S	ATTACH METHOD	MOUNTING METHOD	HORIZ. CLR. (ft.)	LENGTH (ft)			LEFT SUPPORT (ft)			CENTER SUPPORT (ft)			RIGHT SUPPORT (ft)			FOOTING DIAMETER (ft.)	FOOTING DEPTH (ft.)	B/A SUPPORT WEIGHTS (lbs.)	SIMPLE SUPPORT WEIGHTS (lbs.)	REINF. FTGS. (c.y.)	PLAIN FTGS. (c.y.)	FIELD VERIFIED SEE NOTE 2 (mm/dd/yy)
		w	x								h	SNS	HT	MTG HT	EMBED-MENT	S	L	TOTAL LENGTH	S	L	TOTAL LENGTH	S							
101	A	102	X120	7+50 - L-	2	W6x12	BA	N/A	N/A	9.00	10.00	7.47	5	-0.35	17.12	22.12	0.00	0.00	0.00	-0.47	17.00	22.00	1.5	5.5	614.80	0.00	0.72	0.00	
102	A	120	X78	21+78 -L-	2	W6x12	BA	N/A	N/A	18.00	6.50	7.00	4.5	1.15	14.65	19.15	0.00	0.00	0.00	3.73	17.23	21.73	1.5	5	575.92	0.00	0.65	0.00	
103	A	138	X102	22+93 -L-	2	W6x16	BA	N/A	N/A	18.00	8.50	7.00	5.5	0.90	16.40	21.90	0.00	0.00	0.00	2.90	18.40	23.90	1.5	6	865.18	0.00	0.79	0.00	
104	B	138	X42	17+65 RP D	2	W6x9	BA	N/A	N/A	18.00	3.50	7.00	4	2.57	13.07	17.07	0.00	0.00	0.00	4.26	14.76	18.76	1.5	4.5	385.59	0.00	0.59	0.00	
105	A	90	X120	33+65 -L-	2	W6x12	BA	N/A	N/A	8.00	10.00	7.53	4.5	-0.13	17.40	21.90	0.00	0.00	0.00	-0.53	17.00	21.50	1.5	5	606.16	0.00	0.65	0.00	
106A	B	114	X30																										
106B	A	168	X108	5280' from g	2	W10x26	BA	1-R	N/A	30.00	9.00	7.00	6	4.91	20.91	26.91	0.00	0.00	0.00	4.80	20.80	26.80	2.5	6.5	1684.60	0.00	2.36	0.00	
107	A	198	X114	3640' from g	2	W8x18	BA	N/A	N/A	30.00	9.50	7.00	6	2.33	18.83	24.83	0.00	0.00	0.00	1.78	18.28	24.28	2	6.5	1046.12	0.00	1.51	0.00	
108A	B	114	X30																										
108B	A	168	X108	3+75 -Y1-	2	W8x21	BA	1-R	N/A	30.00	9.00	7.00	6	3.13	19.13	25.13	0.00	0.00	0.00	2.90	18.90	24.90	2	6.5	1236.25	0.00	1.51	0.00	
109A	B	114	X30																										
109B	A	168	X126	25+61 -Y1-	2	W10x26	BA	1-R	N/A	21.00	10.50	7.00	6	2.90	20.40	26.40	0.00	0.00	0.00	1.99	19.49	25.49	2.5	6.5	1637.28	0.00	2.36	0.00	
110	B	138	X42	17+95 RP B	2	S4x7.7	BA	N/A	N/A	18.00	3.50	7.00	4	1.60	12.10	16.10	0.00	0.00	0.00	2.71	13.21	17.21	1	4.5	297.10	0.00	0.00	0.26	
111A	B	114	X30																										
111B	A	168	X126	62+90 -Y1-	2	W14x30	BA	1-R	N/A	27.00	10.50	7.00	6	5.04	22.54	28.54	0.00	0.00	0.00	6.70	24.20	30.20	3	6.5	2247.19	0.00	3.40	0.00	
112A	B	114	X30																										
112B	A	168	X108	83+40 -Y1-	2	W10x26	BA	1-R	N/A	30.00	9.00	7.00	6	5.30	21.30	27.30	0.00	0.00	0.00	6.47	22.47	28.47	2.5	6.5	1738.16	0.00	2.36	0.00	
113	A	198	X114	93+50 -Y1-	2	W10x26	BA	N/A	N/A	30.00	9.50	7.00	6	5.22	21.72	27.72	0.00	0.00	0.00	6.90	23.40	29.40	2.5	6.5	1773.26	0.00	2.36	0.00	
114A	B	114	X30																										
114B	A	168	X108	162+60 -Y1-	2	W10x26	BA	1-R	N/A	30.00	9.00	7.00	6	5.11	21.11	27.11	0.00	0.00	0.00	6.63	22.63	28.63	2.5	6.5	1737.46	0.00	2.36	0.00	
201	A	78	X60	35+30 -Y1-	2	S4x7.7	BA	N/A	N/A	5.00	7.00	7.00	4	1.00	13.00	17.00	0.00	0.00	0.00	1.00	13.00	17.00	1	4.5	302.41	0.00	0.00	0.26	
202	A	78	X60	51+92 -Y1-	2	S4x7.7	BA	N/A	N/A	5.00	7.00	7.00	4	1.00	13.00	17.00	0.00	0.00	0.00	1.00	13.00	17.00	1	4.5	302.41	0.00	0.00	0.26	
901	A	90	X108	18+05 RP D	2	W6x16	BA	N/A	N/A	18.00	9.00	7.00	5	2.89	18.89	23.89	0.00	0.00	0.00	2.15	18.15	23.15	1.5	5.5	885.02	0.00	0.72	0.00	
902	A	90	X102	16+80 RP D	2	W6x12	BA	N/A	N/A	18.00	8.50	7.00	4.5	2.43	17.93	22.43	0.00	0.00	0.00	3.31	18.81	23.31	1.5	5	634.24	0.00	0.65	0.00	
903	A	90	X72	16+05 RP D	2	W6x9	BA	N/A	N/A	18.00	6.00	7.00	4	2.23	15.23	19.23	0.00	0.00	0.00	1.74	14.74	18.74	1.5	4.5	404.85	0.00	0.59	0.00	
904	A	90	X102	17+35 RP B	2	W6x12	BA	N/A	N/A	18.00	8.50	7.00	4.5	2.89	18.39	22.89	0.00	0.00	0.00	2.15	17.65	22.15	1.5	5	625.84	0.00	0.65	0.00	
905	A	90	X102	16+65 RP B	2	W6x12	BA	N/A	N/A	18.00	8.50	7.00	4.5	1.87	17.37	21.87	0.00	0.00	0.00	2.60	18.10	22.60	1.5	5	619.00	0.00	0.65	0.00	
906	A	90	X72	15+80 RP B	2	W6x9	BA	N/A	N/A	18.00	6.00	7.00	4	2.38	15.38	19.38	0.00	0.00	0.00	1.87	14.87	18.87	1.5	4.5	407.37	0.00	0.59	0.00	
907	B	144	X42	65+00 -Y1-	2	W6x12	BA	N/A	N/A	30.00	3.50	7.00	4	5.46	15.96	19.96	0.00	0.00	0.00	7.00	17.50	21.50	1.5	4.5	582.88	0.00	0.59	0.00	

TOTAL 21209.13 TOTAL 0.00 TOTAL 26.10 TOTAL 0.79

USE: 21210 0 27 1

NOTES

- DIMENSION "S" REPRESENTS AN INCREASE (+), OR A DECREASE (-) IN POLE LENGTH, RELATIVE TO THE ELEVATION OF THE EDGE OF PAVEMENT.
- FIELD VERIFICATIONS SHALL BE REQUIRED FOR ALL SUPPORTS, SEE (*) ARTICLE 903-3. FABRICATORS SHALL BE AISC CERTIFIED IN CATEGORY 1, SEE (*) ARTICLE 1072-1. (*) = N.C.D.O.T. STANDARD SPECIFICATIONS FOR ROADS AND STRUCTURES
- PLAN LOCATIONS FOR EXISTING UTILITIES ARE BASED ON THE BEST AVAILABLE INFORMATION AND, THEREFORE MAY NOT BE PRECISELY ACCURATE. THEREFORE, IT IS INCUMBENT UPON THE CONTRACTOR TO DETERMINE THE EXACT LOCATION OF UTILITIES BEFORE BEGINNING WORK IN A LOCATION.

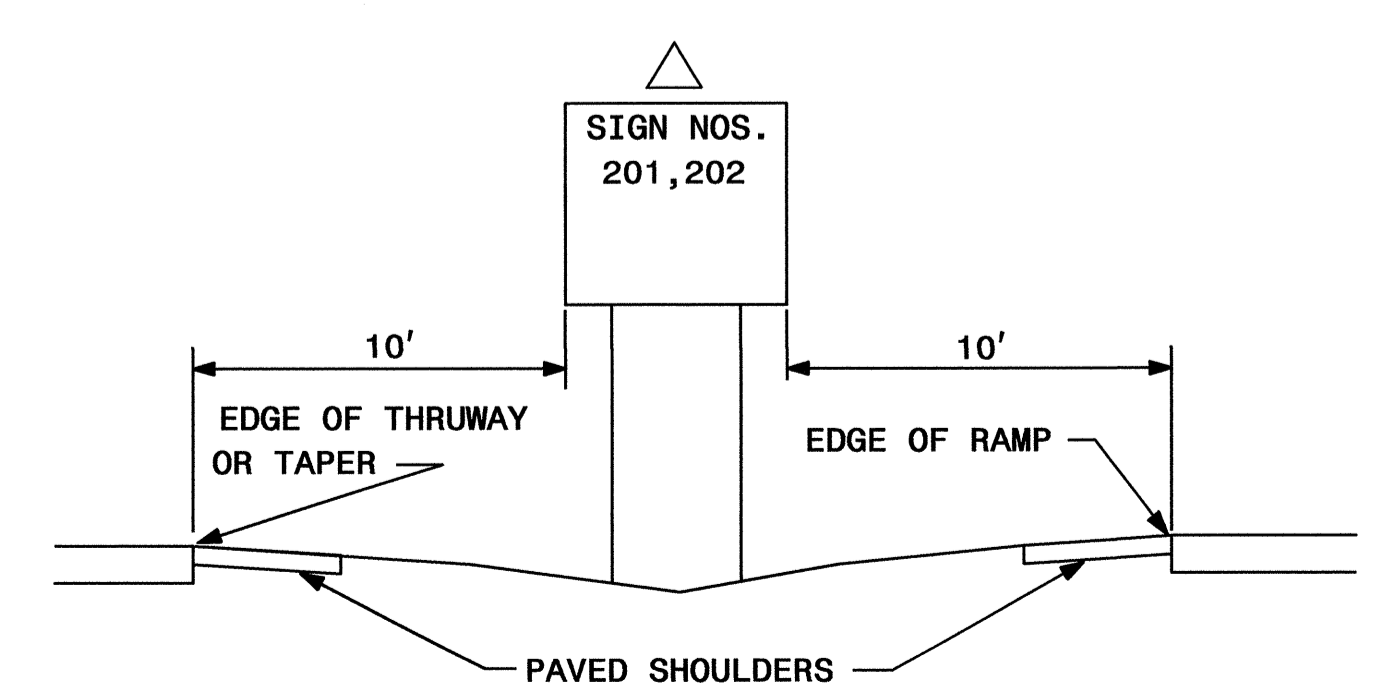
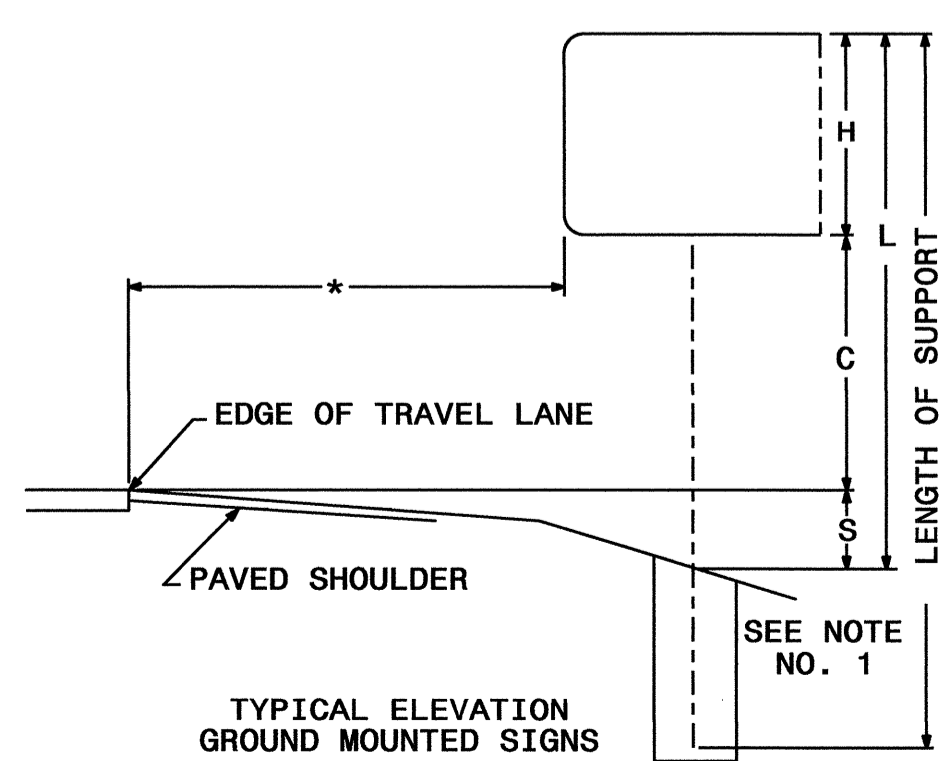

TYPE "A"
GROUND MOUNTED SIGNS

STATE	PROJECT NO.	SHEET NO.	TOTAL SHTS.
N.C.	I-4413	SIGN-2B	

APPROVED: *[Signature]*
DATE: 3/29/12

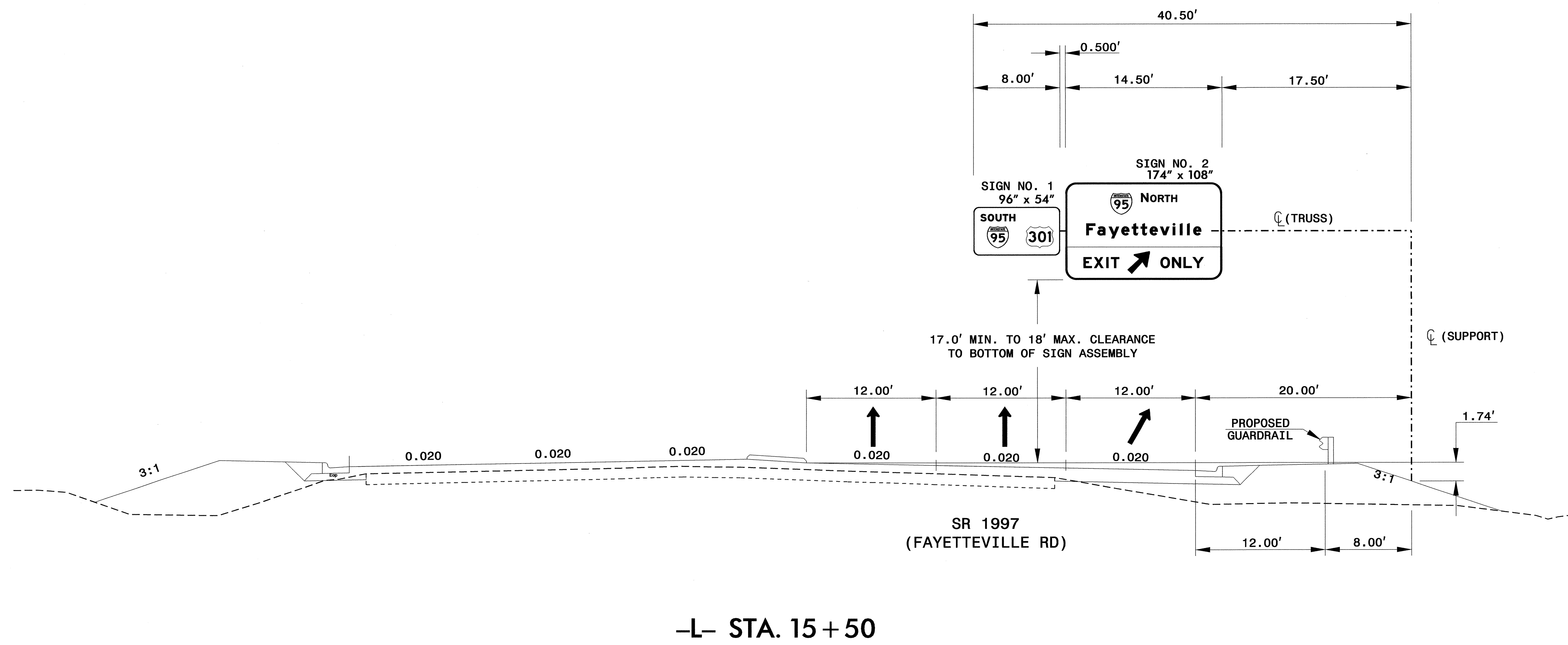

-L- STA. 15+50

NOTES:

- IF THE CONTRACTOR BIDS ALUMINUM SIGN STRUCTURE, EACH SHALL BE PROVIDED WITH AN APPROVED HIGHWAY TRUSS DAMPER DEVICE IN ACCORDANCE WITH AASHTO SPECIFICATIONS.
- MOUNT SIGNS VERTICALLY CENTERED ON HORIZONTAL MEMBER OF STRUCTURE.
- FIELD VERIFICATION SHALL BE REQUIRED FOR ALL FOOTING ELEVATIONS, PER THE LATEST NCDOT STANDARD SPECIFICATIONS FOR ROADS AND STRUCTURES. PROVIDE FIELD VERIFICATION TO THE SIGNING SECTION.
- THE TOP OF THE FOOTING SHALL EXTEND AT LEAST 4 INCHES AND NOT MORE THAN 24 INCHES ABOVE THE HIGHEST POINT OF THE GROUND SURFACE AT THE FOOTING.
- SIGN HANGERS AND ATTACHMENT HARDWARE SHALL BE PROVIDED AND INSTALLED ON THE ASSEMBLY TO ACCOMMODATE ALL SIGNS SHOWN IN THIS PLAN SHEET.
- DESIGN AND CONSTRUCTION REQUIREMENTS FOR SIGN STRUCTURES SHALL ACCOMMODATE WIND VELOCITY OF 110 M.P.H.

OVERHEAD SIGN ASSEMBLY
AT -L- STA. 15+50

STATE	PROJECT NO.	SHEET NO.	TOTAL SHTS.
N.C.	I-4413	SIGN-2C	
APPROVED: <i>[Signature]</i>			
DATE: 3/29/12			
SEAL			
			

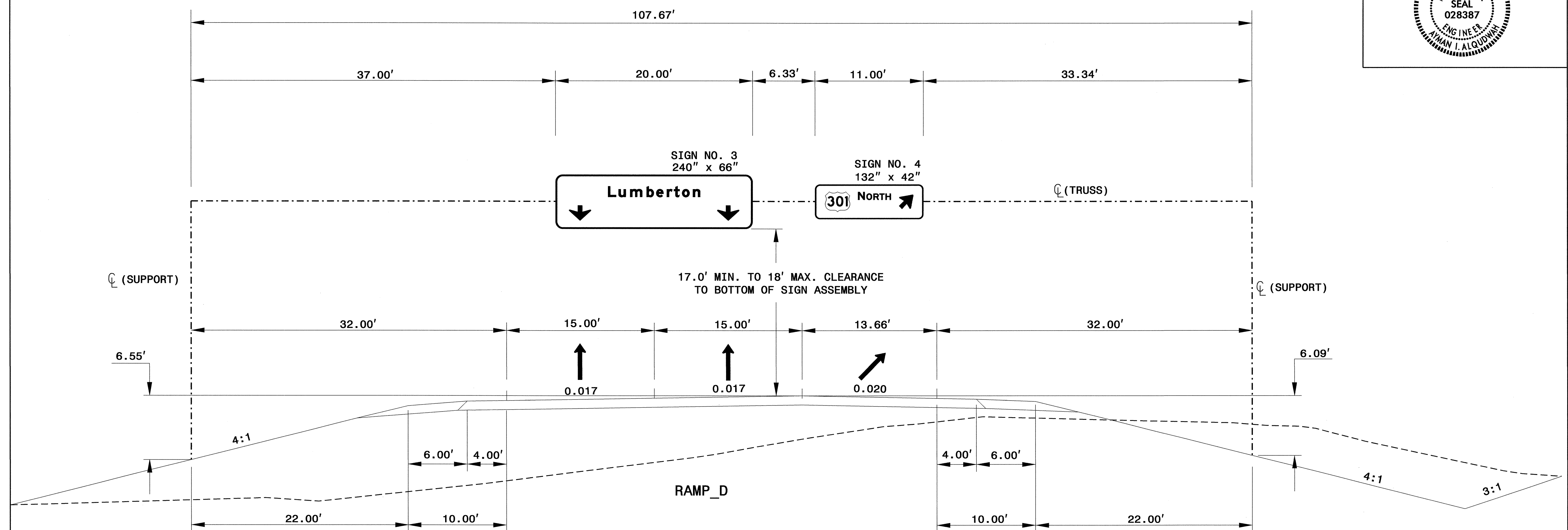

-RAMP D- STA. 19+57

NOTES:

1. IF THE CONTRACTOR BIDS ALUMINUM SIGN STRUCTURE, EACH SHALL BE PROVIDED WITH AN APPROVED HIGHWAY TRUSS DAMPER DEVICE IN ACCORDANCE WITH AASHTO SPECIFICATIONS.
2. MOUNT SIGNS VERTICALLY CENTERED ON HORIZONTAL MEMBER OF STRUCTURE.
3. FIELD VERIFICATION SHALL BE REQUIRED FOR ALL FOOTING ELEVATIONS, PER THE LATEST NCDOT STANDARD SPECIFICATIONS FOR ROADS AND STRUCTURES. PROVIDE FIELD VERIFICATION TO THE SIGNING SECTION.
4. THE TOP OF THE FOOTING SHALL EXTEND AT LEAST 4 INCHES AND NOT MORE THAN 24 INCHES ABOVE THE HIGHEST POINT OF THE GROUND SURFACE AT THE FOOTING.
5. SIGN HANGERS AND ATTACHMENT HARDWARE SHALL BE PROVIDED AND INSTALLED ON THE ASSEMBLY TO ACCOMMODATE ALL SIGNS SHOWN IN THIS PLAN SHEET.
6. DESIGN AND CONSTRUCTION REQUIREMENTS FOR SIGN STRUCTURES SHALL ACCOMMODATE WIND VELOCITY OF 110 M.P.H.

**OVERHEAD SIGN ASSEMBLY
AT -RAMP D- STA. 19+57**

APPROVED: *[Signature]*
 DATE: 3/29/12

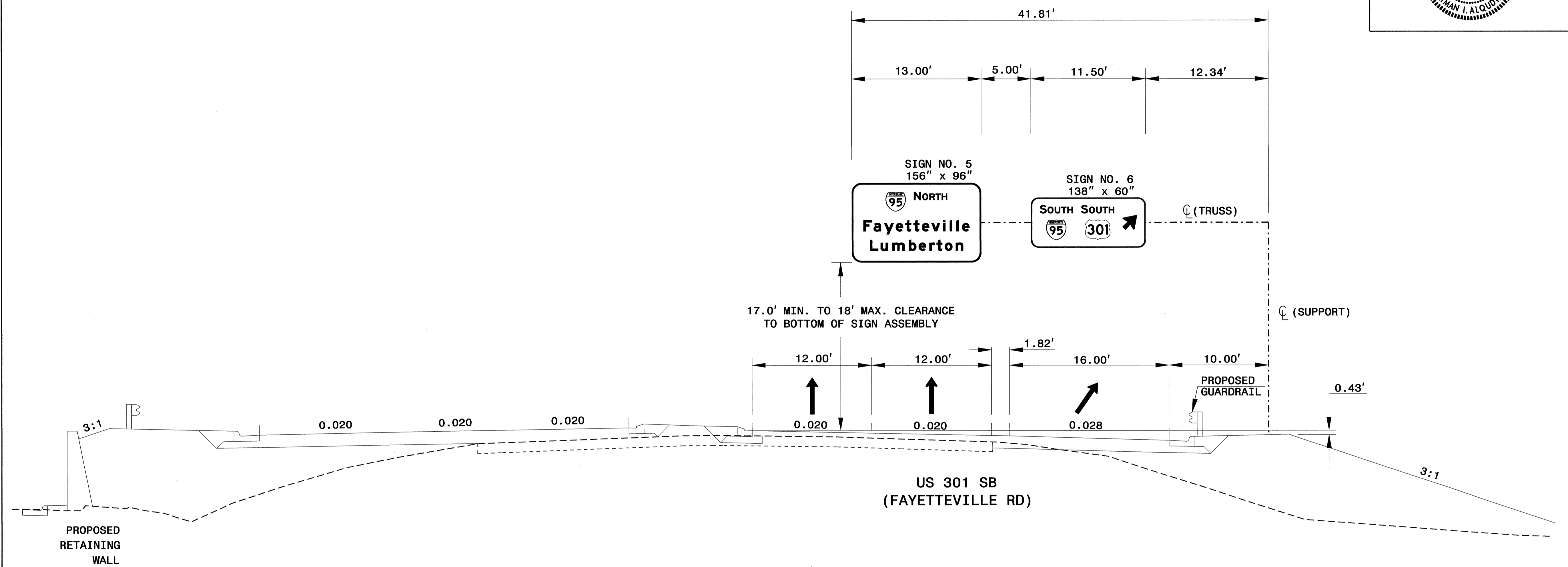

-L- STA. 28 + 45

NOTES:

- IF THE CONTRACTOR BIDS ALUMINUM SIGN STRUCTURE, EACH SHALL BE PROVIDED WITH AN APPROVED HIGHWAY TRUSS DAMPER DEVICE IN ACCORDANCE WITH AASHTO SPECIFICATIONS.
- MOUNT SIGNS VERTICALLY CENTERED ON HORIZONTAL MEMBER OF STRUCTURE.
- FIELD VERIFICATION SHALL BE REQUIRED FOR ALL FOOTING ELEVATIONS, PER THE LATEST NCDOT STANDARD SPECIFICATIONS FOR ROADS AND STRUCTURES. PROVIDE FIELD VERIFICATION TO THE SIGNING SECTION.
- THE TOP OF THE FOOTING SHALL EXTEND AT LEAST 4 INCHES AND NOT MORE THAN 24 INCHES ABOVE THE HIGHEST POINT OF THE GROUND SURFACE AT THE FOOTING.
- SIGN HANGERS AND ATTACHMENT HARDWARE SHALL BE PROVIDED AND INSTALLED ON THE ASSEMBLY TO ACCOMMODATE ALL SIGNS SHOWN IN THIS PLAN SHEET.
- DESIGN AND CONSTRUCTION REQUIREMENTS FOR SIGN STRUCTURES SHALL ACCOMMODATE WIND VELOCITY OF 110 M.P.H.

OVERHEAD SIGN ASSEMBLY
 AT -L- STA. 28+45

STATE	PROJECT NO.	SHEET NO.	TOTAL SHTS.
N.C.	I-4413	SIGN-2E	

APPROVED: *[Signature]*
DATE: 3/29/12

SEAL

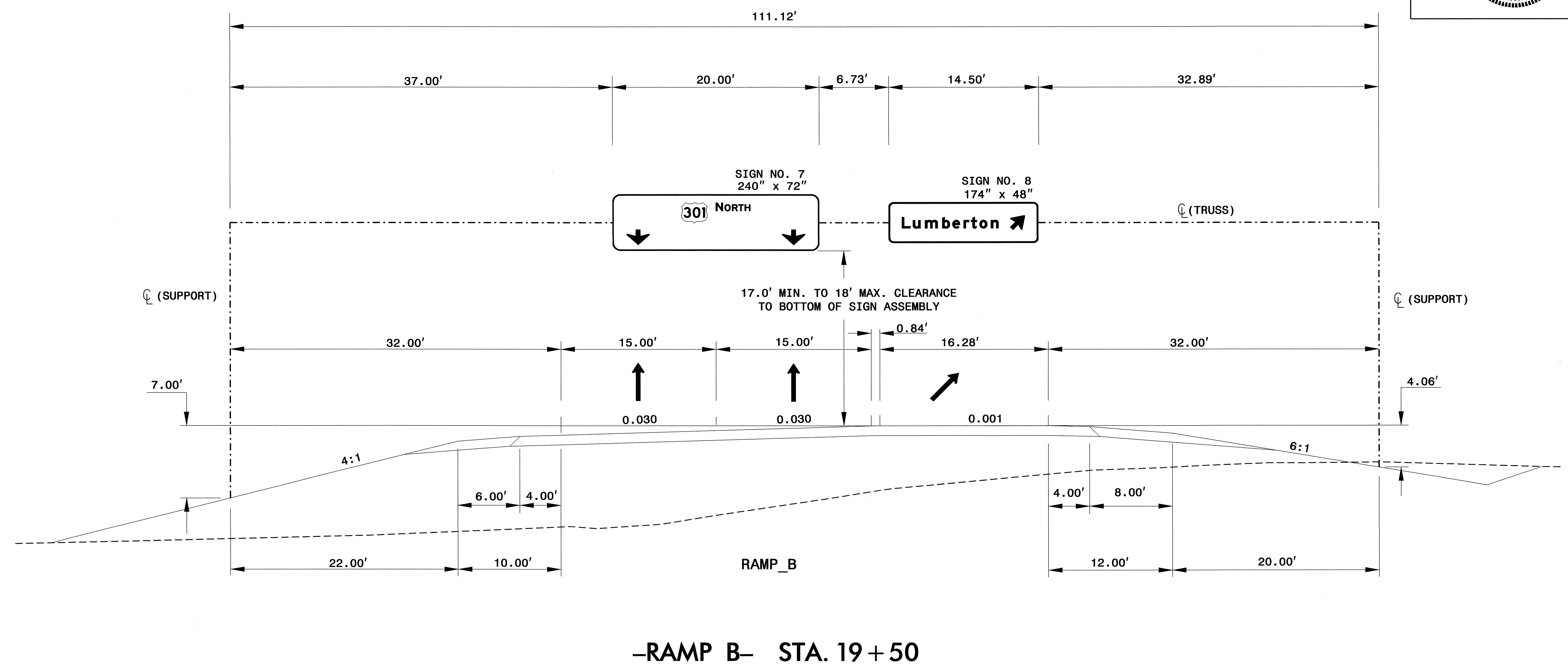

NOTES:

1. IF THE CONTRACTOR BIDS ALUMINUM SIGN STRUCTURE, EACH SHALL BE PROVIDED WITH AN APPROVED HIGHWAY TRUSS DAMPER DEVICE IN ACCORDANCE WITH AASHTO SPECIFICATIONS.
2. MOUNT SIGNS VERTICALLY CENTERED ON HORIZONTAL MEMBER OF STRUCTURE.
3. FIELD VERIFICATION SHALL BE REQUIRED FOR ALL FOOTING ELEVATIONS, PER THE LATEST NCDOT STANDARD SPECIFICATIONS FOR ROADS AND STRUCTURES. PROVIDE FIELD VERIFICATION TO THE SIGNING SECTION.
4. THE TOP OF THE FOOTING SHALL EXTEND AT LEAST 4 INCHES AND NOT MORE THAN 24 INCHES ABOVE THE HIGHEST POINT OF THE GROUND SURFACE AT THE FOOTING.
5. SIGN HANGERS AND ATTACHMENT HARDWARE SHALL BE PROVIDED AND INSTALLED ON THE ASSEMBLY TO ACCOMMODATE ALL SIGNS SHOWN IN THIS PLAN SHEET.
6. DESIGN AND CONSTRUCTION REQUIREMENTS FOR SIGN STRUCTURES SHALL ACCOMMODATE WIND VELOCITY OF 110 M.P.H.

**OVERHEAD SIGN ASSEMBLY
AT -RAMP B- STA. 19+50**

TIP NO. I-4413	SHEET NO. SIGN-3A
APPROVED: <i>[Signature]</i>	
DATE: 3/29/12	
SEAL	



SIGN NUMBER: 1 TYPE: B QUANTITY: 1	BACKG COLOR: Green COPY COLOR: White	DESIGN BY: EEW PROJECT ID: I-4413	CHECKED BY: DIV: 6	DATE: Nov 16, 2011
--	---	--------------------------------------	-----------------------	--------------------

SYMBOL	X	Y	WID	HT
M1_1	14.9	8	24	24
M1_4	58.3	8	30	24

SIGN WIDTH: 8'-0"
HEIGHT: 4'-6"
TOTAL AREA: 36.0 Sq.Ft.

BORDER TYPE: FLUSH
RECESS: 0"
WIDTH: 1"
RADIUS: 6"

NO. Z BARS: 2
LENGTH: 88.0

MAT'L: 0.125" (3.2 mm) ALUMINUM

USE NOTES: 1,2,3

- Legend and border (except those that are colored black) shall be direct applied Grade A sheeting.
- Background shall be Grade C reflective sheeting.
- Shields: A, B, and C type arrows shall be on 0.032" (0.8mm) aluminum and demountable.
- Bottom panel shall be yellow Grade C sheeting. Legend shall be direct applied black non-reflective sheeting. Yellow panel is:

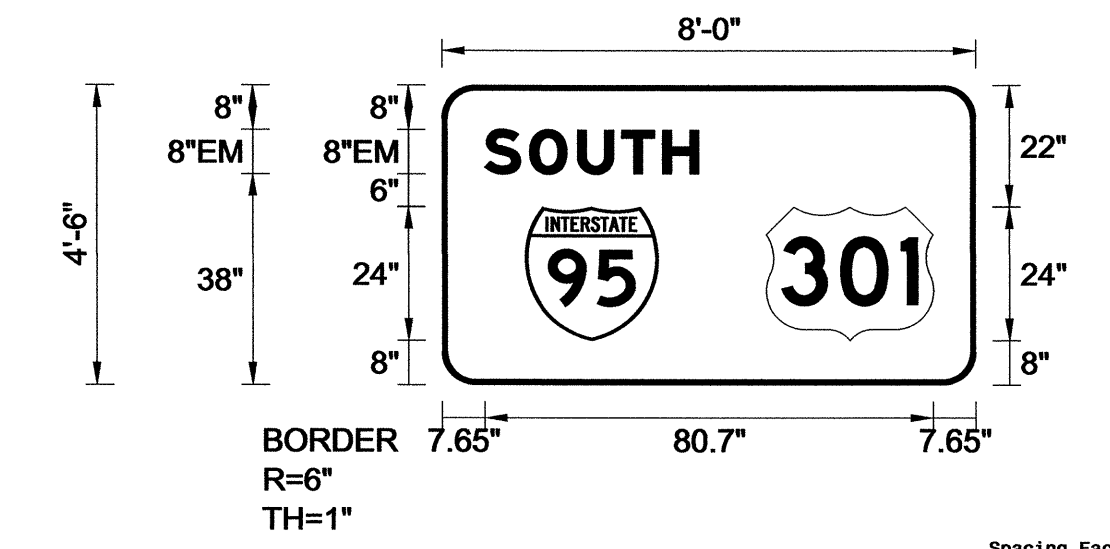

LETTER POSITIONS

Letter spacings are to start of next letter										Series/Size
										Text Length
S	O	U	T	H						EM 2000
7.7	6.5	1.7	8.6	7.9	7.4	6.5	49.8			38.6

FILENAME: I-4413 Guidesign NORTH CAROLINA D.O.T. SIGN DETAIL

SIGN NUMBER: 2 TYPE: A QUANTITY: 1	BACKG COLOR: Green/Yellow COPY COLOR: White/Black	DESIGN BY: EEW PROJECT ID: I-4413	CHECKED BY: DIV: 6	DATE: Mar 16, 2012
--	--	--------------------------------------	-----------------------	--------------------

SYMBOL	X	Y	WID	HT
M1_1	50	72.4	24	24
AR_Type A	69	6.6	20	31.5

SIGN WIDTH: 14'-6"
HEIGHT: 9'-0"
TOTAL AREA: 130.5 Sq.Ft.

BORDER TYPE: FLUSH
RECESS: 0"
WIDTH: 2"
RADIUS: 12"

NO. Z BARS: 3
LENGTH: 166.0

MAT'L: 0.125" (3.2 mm) ALUMINUM

USE NOTES: 1,2,3,4

- Legend and border (except those that are colored black) shall be direct applied Grade A sheeting.
- Background shall be Grade C reflective sheeting.
- Shields: A, B, and C type arrows shall be on 0.032" (0.8mm) aluminum and demountable.
- Bottom panel shall be yellow Grade C sheeting. Legend shall be direct applied black non-reflective sheeting. Yellow panel is: 174" X 30"

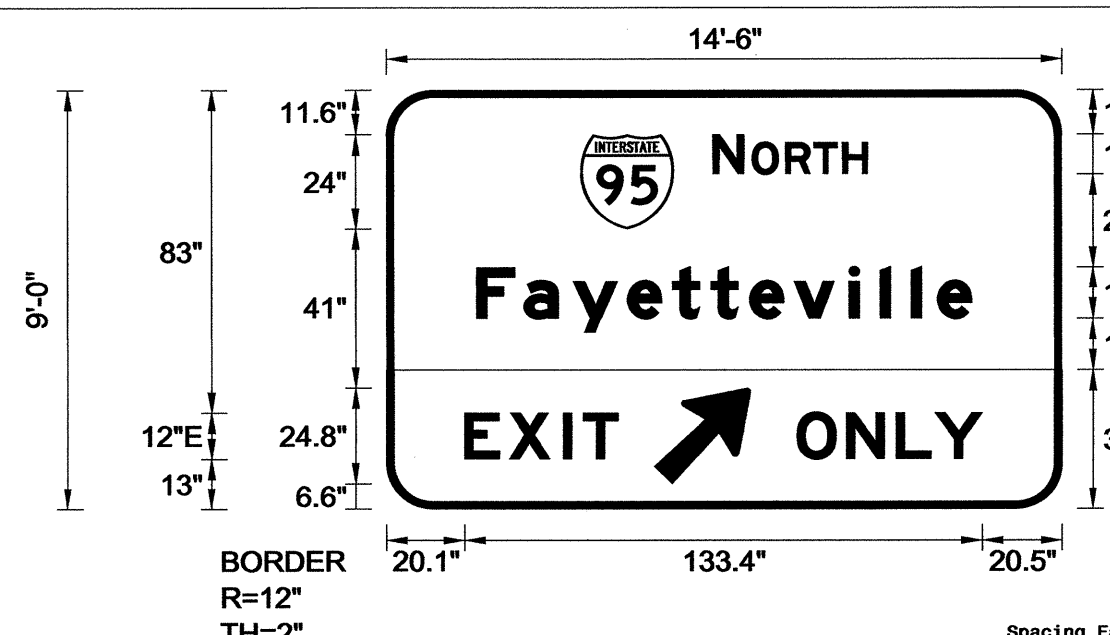

LETTER POSITIONS

Letter spacings are to start of next letter										Series/Size				
										Text Length				
N	O	R	T	H						EM 2000				
84	8.1	2.1	8.6	7.4	7.4	6.5	50			40				
F	a	y	e	t	e	v	i	l	e	EM 2000				
23.2	12.3	12.7	14	11.6	9.9	10	11.5	14.1	8	8	6.8	8.8	23.2	127.6
E	X	I	T								EM 2000			
20.1	11.4	13.9	5.1	9	114.4							39.5		
O	N	L	Y								E 2000			
105.7	12.8	12.8	9.9	12.2	20.5							47.8		

FILENAME: I-4413 Guidesign NORTH CAROLINA D.O.T. SIGN DETAIL

SIGN NUMBER: 3 TYPE: A QUANTITY: 1	BACKG COLOR: Green COPY COLOR: White	DESIGN BY: EEW PROJECT ID: I-4413	CHECKED BY: DIV: 6	DATE: Mar 16, 2012
--	---	--------------------------------------	-----------------------	--------------------

SYMBOL	X	Y	WID	HT
ARDOWN	18	10.1	24	16.5
ARDOWN	198	10.1	24	16.5

SIGN WIDTH: 20'-0"
HEIGHT: 5'-6"
TOTAL AREA: 110.0 Sq.Ft.

BORDER TYPE: FLUSH
RECESS: 0"
WIDTH: 2"
RADIUS: 9"

NO. Z BARS: 2
LENGTH: 232.0

MAT'L: 0.125" (3.2 mm) ALUMINUM

USE NOTES: 1,2,3

- Legend and border (except those that are colored black) shall be direct applied Grade A sheeting.
- Background shall be Grade C reflective sheeting.
- Shields: A, B, and C type arrows shall be on 0.032" (0.8mm) aluminum and demountable.
- Bottom panel shall be yellow Grade C sheeting. Legend shall be direct applied black non-reflective sheeting. Yellow panel is:

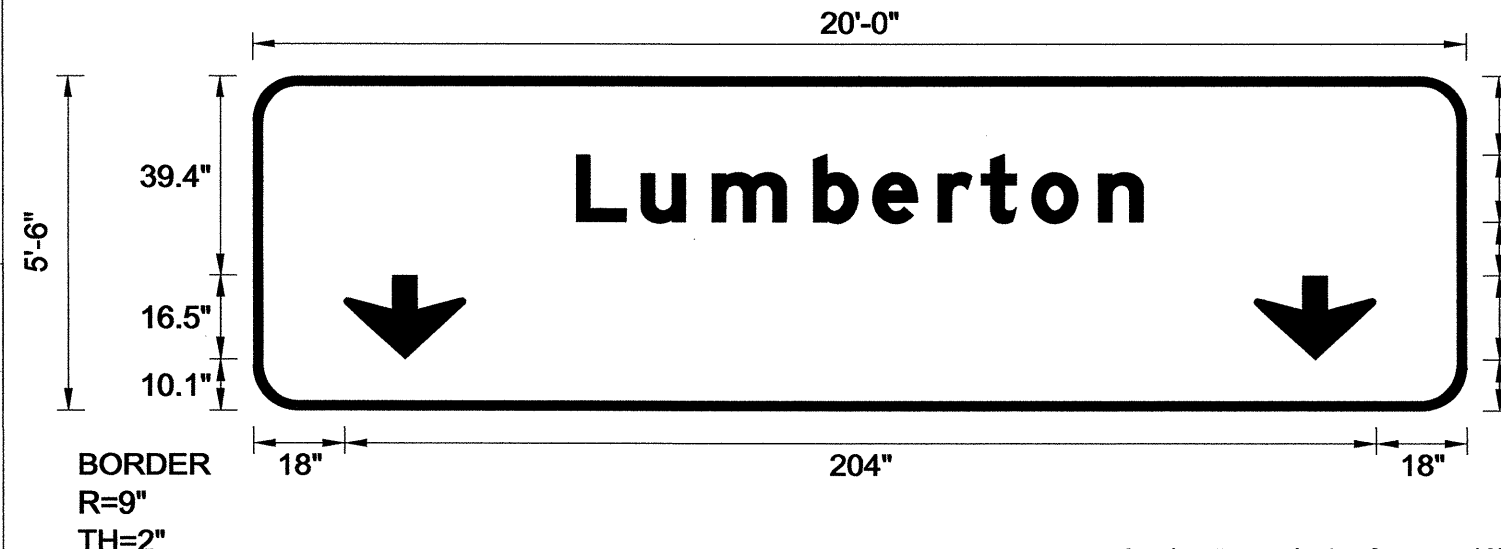

LETTER POSITIONS

Letter spacings are to start of next letter										Series/Size	
										Text Length	
L	u	m	b	e	r	t	o	n			EM 2000
63.9	12.8	14.1	20	11.7	12.9	8.5	10	13.2	8.8	63.9	112.1

FILENAME: I-4413 Guidesign NORTH CAROLINA D.O.T. SIGN DETAIL

SIGN NUMBER: 4 TYPE: B QUANTITY: 1	BACKG COLOR: Green COPY COLOR: White	DESIGN BY: EEW PROJECT ID: I-4413	CHECKED BY: DIV: 6	DATE: Nov 16, 2011
--	---	--------------------------------------	-----------------------	--------------------

SYMBOL	X	Y	WID	HT
ARSHRT	102.4	12.4	19.2	21.6
M1_4	12.4	9	30	24

SIGN WIDTH: 11'-0"
HEIGHT: 3'-6"
TOTAL AREA: 38.5 Sq.Ft.

BORDER TYPE: FLUSH
RECESS: 0"
WIDTH: 1.5"
RADIUS: 6"

NO. Z BARS: 2
LENGTH: 124.0

MAT'L: 0.125" (3.2 mm) ALUMINUM

USE NOTES: 1,2,3

- Legend and border (except those that are colored black) shall be direct applied Grade A sheeting.
- Background shall be Grade C reflective sheeting.
- Shields: A, B, and C type arrows shall be on 0.032" (0.8mm) aluminum and demountable.
- Bottom panel shall be yellow Grade C sheeting. Legend shall be direct applied black non-reflective sheeting. Yellow panel is:

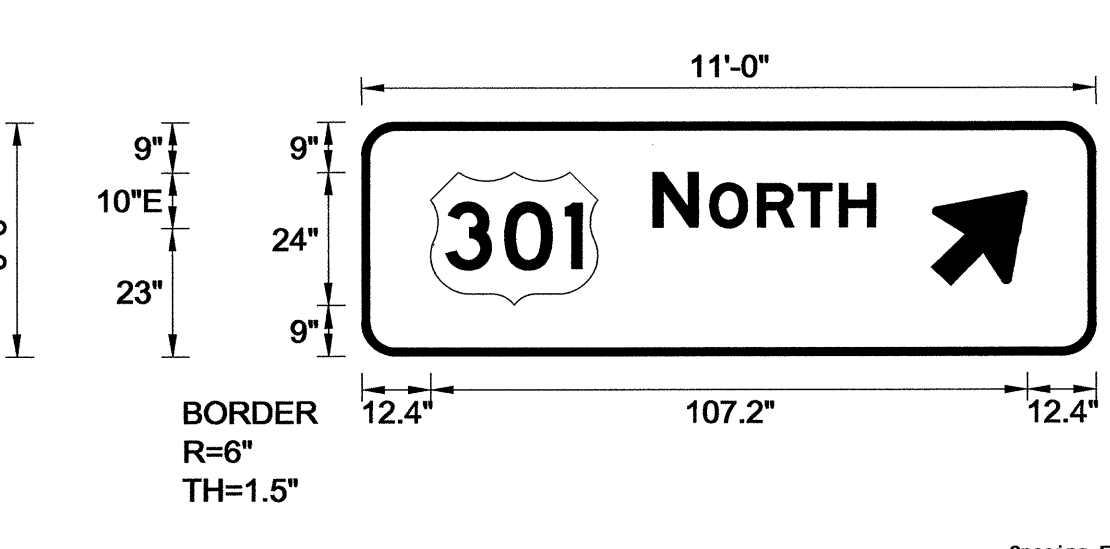

LETTER POSITIONS

Letter spacings are to start of next letter										Series/Size
										Text Length
N	O	R	T	H						EM 2000
52.4	8.1	2.1	8.6	7.4	7.4	6.5	39.6			40

FILENAME: I-4413 Guidesign NORTH CAROLINA D.O.T. SIGN DETAIL

20-MAR-2012 10:28 P:\IP\Projects\I-4413\I-4413\Sign Designs\I-4413 Guidesign.dgn

TYPE "A" & "B" SIGNS

TIP NO. I-4413	SHEET NO. SIGN-3B
APPROVED: <i>[Signature]</i>	
DATE: 3/27/12	
SEAL	



SIGN NUMBER: 5 TYPE: A QUANTITY: 1 SIGN WIDTH: 13'-0" HEIGHT: 8'-0" TOTAL AREA: 104.0 Sq.Ft. BORDER TYPE: FLUSH RECESS: 0" WIDTH: 2" RADII: 12" NO. Z BARS: 3 LENGTH: 148.0	BACKG COLOR: Green COPY COLOR: White SYMBOL X Y WID HT M1_1 41 61.1 24 24	DESIGN BY: EEW PROJECT ID: I-4413 CHECKED BY: DIV: 6 DATE: Nov 16, 2011
--	--	--

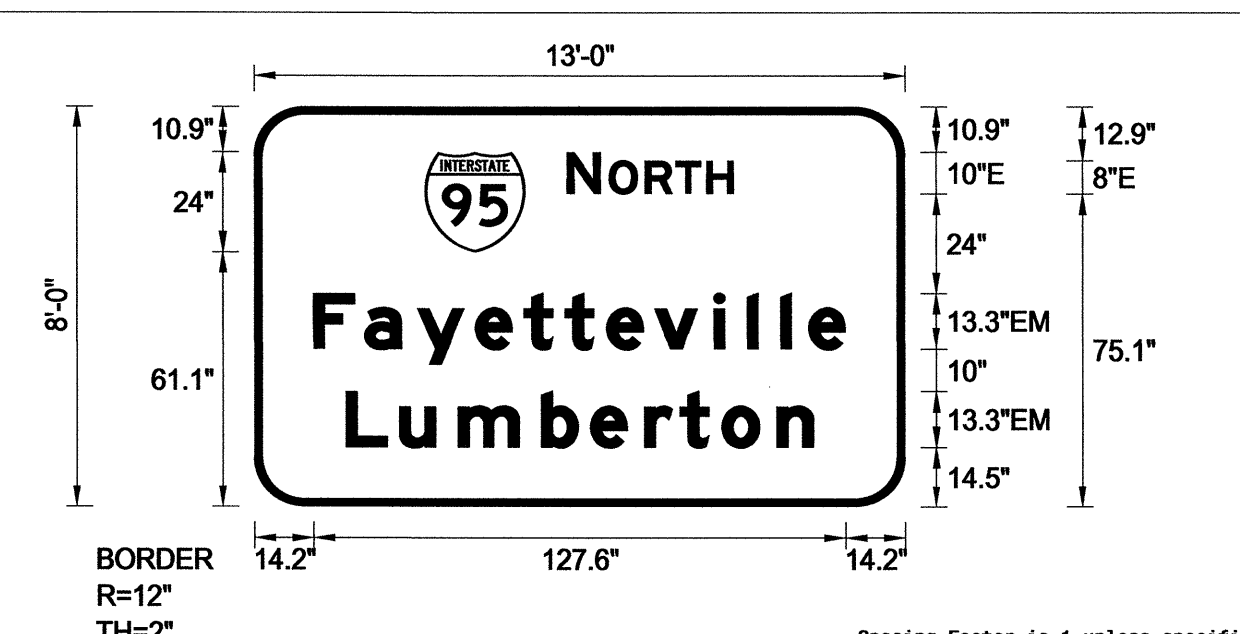

BORDER R=12" TH=2" Spacing Factor is 1 unless specified otherwise

Letter positions										Series/Size
Letter spacings are to start of next letter										Text Length
75	8.1	2.1	8.6	7.4	7.4	6.5	41			E 2000
										40
										EW 2000
										127.6
										EW 2000
										112.1

FILENAME: I-4413 Guidesign NORTH CAROLINA D.O.T. SIGN DETAIL

SIGN NUMBER: 7 TYPE: A QUANTITY: 1 SIGN WIDTH: 20'-0" HEIGHT: 6'-0" TOTAL AREA: 120.0 Sq.Ft. BORDER TYPE: FLUSH RECESS: 0" WIDTH: 2" RADII: 9" NO. Z BARS: 2 LENGTH: 232.0	BACKG COLOR: Green COPY COLOR: White SYMBOL X Y WID HT M1_4 74.3 34.5 30 24 ARDOWN 18 9.1 24 16.5 ARDOWN 198 9.1 24 16.5	DESIGN BY: EEW PROJECT ID: I-4413 CHECKED BY: DIV: 6 DATE: Mar 16, 2012
---	---	--

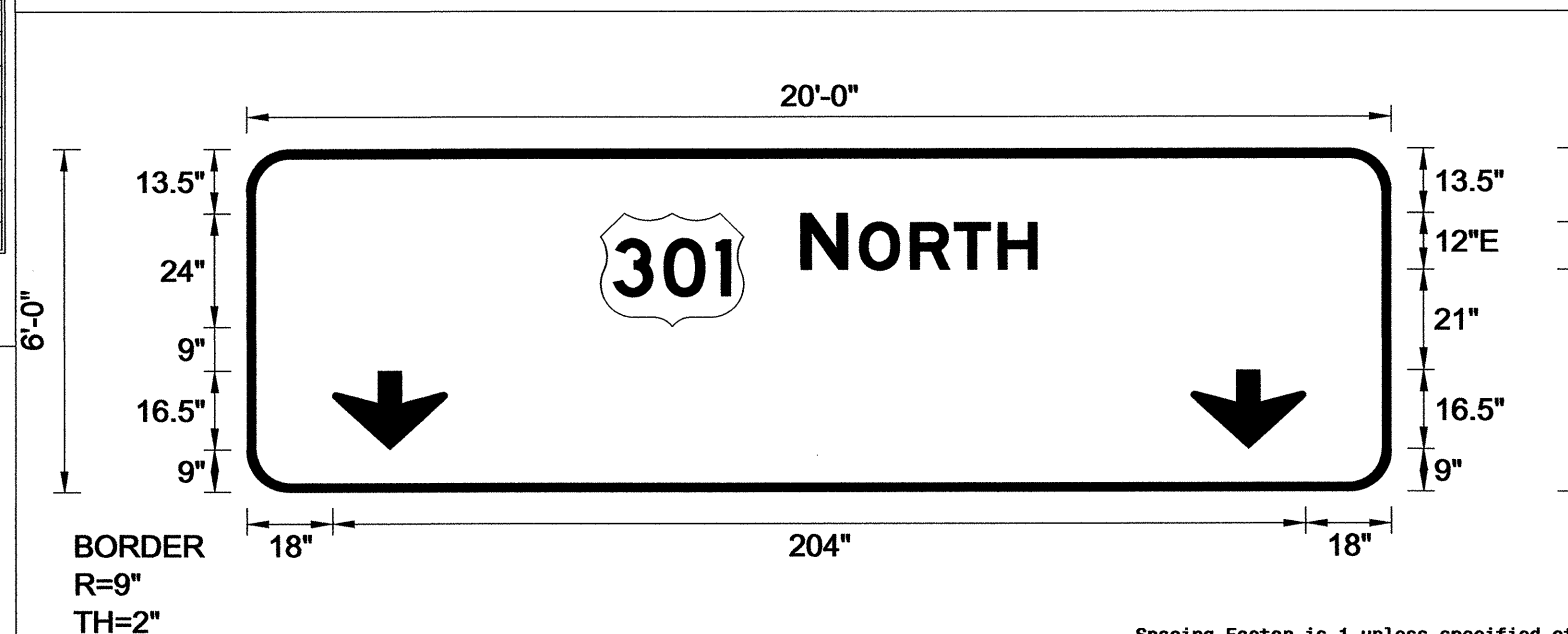

BORDER R=9" TH=2" Spacing Factor is 1 unless specified otherwise

Letter positions										Series/Size
Letter spacings are to start of next letter										Text Length
116.3	9.7	2.6	10.7	9.2	9.2	8.1	74.3			E 2000
										49.5
										EW 2000
										127.6
										EW 2000
										112.1

FILENAME: I-4413 Guidesign NORTH CAROLINA D.O.T. SIGN DETAIL

SIGN NUMBER: 6 TYPE: A QUANTITY: 1 SIGN WIDTH: 11'-6" HEIGHT: 5'-0" TOTAL AREA: 57.5 Sq.Ft. BORDER TYPE: FLUSH RECESS: 0" WIDTH: 1.5" RADII: 9" NO. Z BARS: 2 LENGTH: 130.0	BACKG COLOR: Green COPY COLOR: White SYMBOL X Y WID HT ARSHRT 110.2 21.4 19.2 21.6 M1_1 18.5 9.3 24 24 M1_4 65.3 9.3 30 24	DESIGN BY: EEW PROJECT ID: I-4413 CHECKED BY: DIV: 6 DATE: Nov 16, 2011
--	---	--

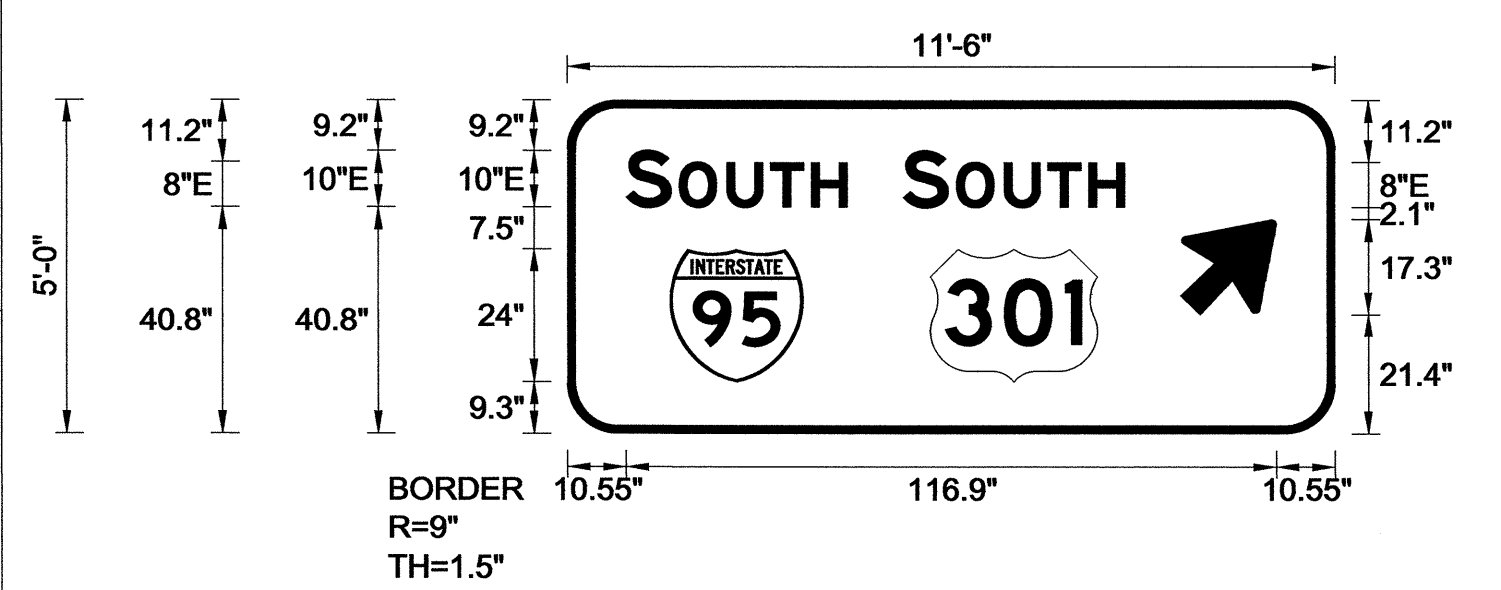

BORDER R=9" TH=1.5" Spacing Factor is 1 unless specified otherwise

Letter positions										Series/Size
Letter spacings are to start of next letter										Text Length
10.5	8.1	1.5	8.6	7.8	7.4	6.5	87.6			E 2000
										39.8
										EW 2000
										39.8
										EW 2000
										112.1

FILENAME: I-4413 Guidesign NORTH CAROLINA D.O.T. SIGN DETAIL

SIGN NUMBER: 8 TYPE: A QUANTITY: 1 SIGN WIDTH: 14'-6" HEIGHT: 4'-0" TOTAL AREA: 58.0 Sq.Ft. BORDER TYPE: FLUSH RECESS: 0" WIDTH: 2" RADII: 6" NO. Z BARS: 2 LENGTH: 166.0	BACKG COLOR: Green COPY COLOR: White SYMBOL X Y WID HT ARSHRT 141.1 15.4 19.2 21.6	DESIGN BY: EEW PROJECT ID: I-4413 CHECKED BY: DIV: 6 DATE: Nov 16, 2011
--	---	--

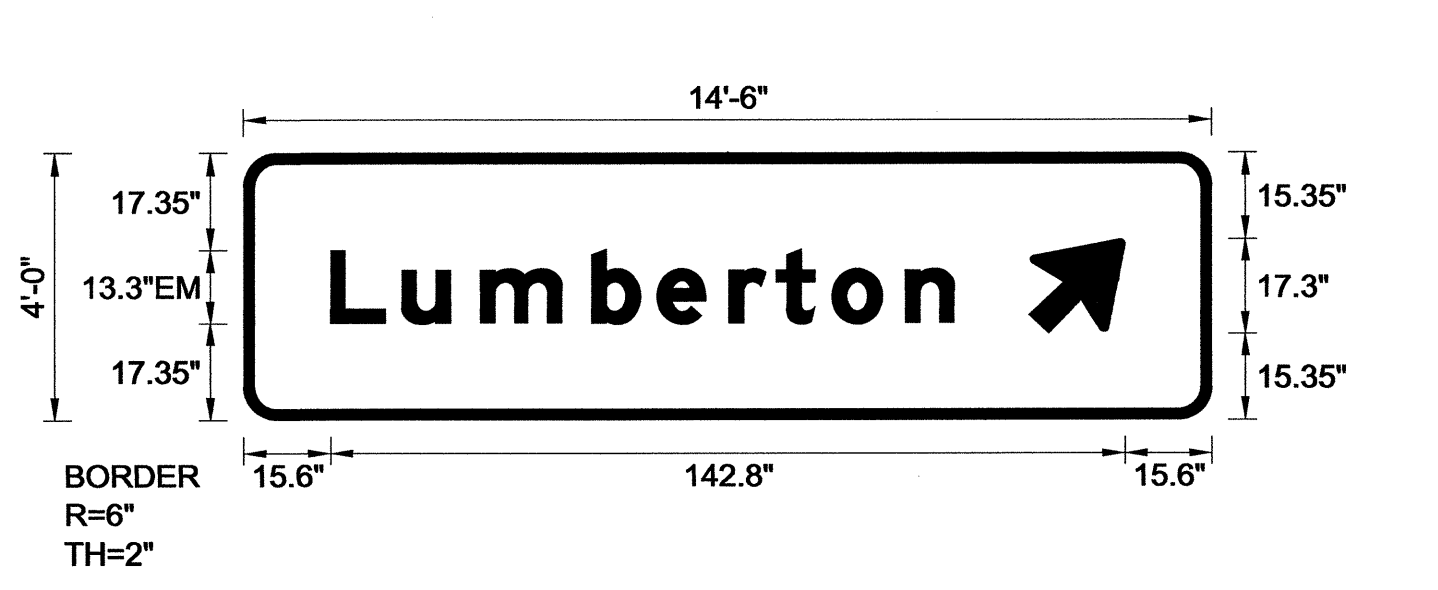

BORDER R=6" TH=2" Spacing Factor is 1 unless specified otherwise

Letter positions										Series/Size
Letter spacings are to start of next letter										Text Length
15.6	12.8	14.1	20	11.7	12.9	8.5	10	13.2	8.8	46.3
										112.1
										EW 2000
										112.1
										EW 2000
										112.1

FILENAME: I-4413 Guidesign NORTH CAROLINA D.O.T. SIGN DETAIL

TYPE "A" SIGNS

20-MAR-2012 10:32
 P:\TIP\Projects\I-4413\Office\Sign Design\I-4413 Guidesign.dgn
 erickward AT 1/24/10

TIP NO. I-4413	SHEET NO. SIGN-3C
APPROVED: <i>[Signature]</i>	
DATE: 3/29/12	
SEAL	

SIGN NUMBER: 101 **BACKG COLOR:** Green/Green
TYPE: A **COPY COLOR:** White

QUANTITY: 1

SYMBOL	X	Y	WID	HT
M1_1	18.4	74.5	24	24
M1_4	53.6	74.5	30	24
M1_1	15.4	22.3	24	24

SIGN WIDTH: 8'-6"
HEIGHT: 10'-0"
TOTAL AREA: 85.0 Sq.Ft.

BORDER TYPE: FLUSH
RECESS: 0"
WIDTH: 1"
RADII: 12"

NO. Z BARS: 3
LENGTH: 94.0

MAT'L: 0.125" (3.2 mm) ALUMINUM

DESIGN BY: EEW **CHECKED BY:** **DATE:** Nov 16, 2011
PROJECT ID: I-4413 **DIV:** 6

USE NOTES: 1,2,3

- Legend and border(except those that are colored black) shall be direct applied Grade C sheeting.
- Background shall be Grade C reflective sheeting.
- Shields; A, B, and C type arrows shall be on 0.032" (0.8mm) aluminum and demountable.

Spacing Factor is 1 unless specified otherwise

LETTER POSITIONS

Letter spacings are to start of next letter

Letter	Series/Size	Text Length
S	E 2000	15.2
O	E 2000	6.5
U	E 2000	1.2
T	E 2000	6.4
H	E 2000	5.9
... (other letters and spacings) ...		

FILENAME: I-4413 Guidesign NORTH CAROLINA D.O.T. SIGN DETAIL

SIGN NUMBER: 103 **BACKG COLOR:** Green / Green
TYPE: A **COPY COLOR:** White

QUANTITY: 1

SYMBOL	X	Y	WID	HT
AR_Type B	14.8	71.7	15.1	17.2
M1_4	43.3	68.3	30	24
AR_Type B	10.6	22.9	15.1	17.2
M1_1	45.7	9.7	24	24
M1_4	92.5	9.7	30	24

SIGN WIDTH: 11'-6"
HEIGHT: 8'-6"
TOTAL AREA: 97.8 Sq.Ft.

BORDER TYPE: FLUSH
RECESS: 0"
WIDTH: 1.5"
RADII: 12"

NO. Z BARS: 3
LENGTH: 130.0

MAT'L: 0.125" (3.2 mm) ALUMINUM

DESIGN BY: EEW **CHECKED BY:** **DATE:** Mar 07, 2012
PROJECT ID: I-4413 **DIV:** 6

USE NOTES: 1,2,3

- Legend and border(except those that are colored black) shall be direct applied Grade C sheeting.
- Background shall be Grade C reflective sheeting.
- Shields; A, B, and C type arrows shall be on 0.032" (0.8mm) aluminum and demountable.

Spacing Factor is 1 unless specified otherwise

LETTER POSITIONS

Letter spacings are to start of next letter

Letter	Series/Size	Text Length
N	E 2000	83.3
O	E 2000	8.1
R	E 2000	2.1
T	E 2000	8.6
H	E 2000	7.4
... (other letters and spacings) ...		

FILENAME: I-4413 Guidesign NORTH CAROLINA D.O.T. SIGN DETAIL

SIGN NUMBER: 102 **BACKG COLOR:** Green / Green
TYPE: A **COPY COLOR:** White

QUANTITY: 1

SYMBOL	X	Y	WID	HT
AR_Type B	14.8	54.7	15.1	17.2
M1_1	41.3	20.1	24	24
AR_Type B	9.1	17.5	15.1	17.2

SIGN WIDTH: 10'-0"
HEIGHT: 6'-6"
TOTAL AREA: 65.0 Sq.Ft.

BORDER TYPE: FLUSH
RECESS: 0"
WIDTH: 1"
RADII: 9"

NO. Z BARS: 2
LENGTH: 112.0

MAT'L: 0.125" (3.2 mm) ALUMINUM

DESIGN BY: EEW **CHECKED BY:** **DATE:** Mar 06, 2012
PROJECT ID: I-4413 **DIV:** 6

USE NOTES: 1,2,3

- Legend and border(except those that are colored black) shall be direct applied Grade C sheeting.
- Background shall be Grade C reflective sheeting.
- Shields; A, B, and C type arrows shall be on 0.032" (0.8mm) aluminum and demountable.

Spacing Factor is 1 unless specified otherwise

LETTER POSITIONS

Letter spacings are to start of next letter

Letter	Series/Size	Text Length
L	E 2000	37.9
U	E 2000	7.7
M	E 2000	8.5
B	E 2000	12
E	E 2000	7
R	E 2000	7.8
T	E 2000	5.1
H	E 2000	6
... (other letters and spacings) ...		

FILENAME: I-4413 Guidesign NORTH CAROLINA D.O.T. SIGN DETAIL

SIGN NUMBER: 104 **BACKG COLOR:** Green/Blue/Green
TYPE: B **COPY COLOR:** White

QUANTITY: 1

SYMBOL	X	Y	WID	HT
AR_Type D	9.4	31.8	6	9
AR_Type D	17.3	18	6	9
AR_Type D	122	4.3	6	9

SIGN WIDTH: 11'-6"
HEIGHT: 3'-6"
TOTAL AREA: 40.3 Sq.Ft.

BORDER TYPE: FLUSH
RECESS: 0"
WIDTH: 0.75"
RADII: 6"

NO. Z BARS: 2
LENGTH: 130.0

MAT'L: 0.125" (3.2 mm) ALUMINUM

DESIGN BY: EEW **CHECKED BY:** **DATE:** Mar 07, 2012
PROJECT ID: I-4413 **DIV:** 6

USE NOTES: 1,2

- Legend and border(except those that are colored black) shall be direct applied Grade C sheeting.
- Background shall be Grade C reflective sheeting.
- Shields; A, B, and C type arrows shall be on 0.032" (0.8mm) aluminum and demountable.

Spacing Factor is 1 unless specified otherwise

LETTER POSITIONS

Letter spacings are to start of next letter

Letter	Series/Size	Text Length
D	E 2000	24.4
M	E 2000	5.4
V	E 2000	5.6
D	E 2000	4.6
r	E 2000	6
i	E 2000	5.3
v	E 2000	3
e	E 2000	1.7
r	E 2000	4.7
s	E 2000	4.4
L	E 2000	2.6
i	E 2000	6
c	E 2000	4.5
e	E 2000	1.9
n	E 2000	4.1
s	E 2000	4.4
e	E 2000	4.3
O	E 2000	3.4
f	E 2000	3.5
f	E 2000	6
i	E 2000	5.1
c	E 2000	2.5
e	E 2000	2.9
1	E 2000	1.9
l	E 2000	4.1
e	E 2000	3.5
9	E 2000	4.104.2
H	E 2000	32.3
i	E 2000	5.4
g	E 2000	1.9
h	E 2000	4.8
w	E 2000	4.2
a	E 2000	7.2
y	E 2000	4.1
P	E 2000	4.5
a	E 2000	6
t	E 2000	4.6
r	E 2000	3.1
o	E 2000	2.8
S	E 2000	6
t	E 2000	4.4
a	E 2000	3.1
t	E 2000	1.9
i	E 2000	4.6
o	E 2000	3.5
n	E 2000	17.3
R	E 2000	7
o	E 2000	4.7
b	E 2000	4.6
e	E 2000	3.4
s	E 2000	4.6
o	E 2000	3.5
n	E 2000	6
C	E 2000	4.6
o	E 2000	7.1
m	E 2000	4.7
u	E 2000	1.6
n	E 2000	2.6
i	E 2000	4.5
t	E 2000	6
y	E 2000	5
C	E 2000	4.6
o	E 2000	2.2
l	E 2000	1.9
l	E 2000	4.1
e	E 2000	4.6
g	E 2000	3.5
e	E 2000	22
109.1		

FILENAME: I-4413 Guidesign NORTH CAROLINA D.O.T. SIGN DETAIL

20-MAR-2012 10:33
 P:\TIP-Projects\I-4413\Traffic\Signs\CADD\Sign Designs\I-4413 Guidesign.dgn
 ericward - AT 12/24/2015

TYPE "A" & "B" SIGNS

TIP NO.	SHEET NO.
I-4413	SIGN-3D
APPROVED: <i>[Signature]</i>	
DATE: 3/29/12	
SEAL	



SIGN NUMBER: 105
TYPE: A
QUANTITY: 1
SIGN WIDTH: 7'-6"
HEIGHT: 10'-0"
TOTAL AREA: 75.0 Sq.Ft.
BORDER TYPE: FLUSH
RECESS: 0"
WIDTH: 1"
RADIUS: 12"
NO. Z BARS: 3
LENGTH: 82.0

BACKG COLOR: Green/Green
COPY COLOR: White

SYMBOL	X	Y	WID	HT
M1_1	12.4	88.5	24	24
M1_1	12.6	22.3	24	24
M1_4	47.4	22.3	30	24

MAT'L: 0.125" (3.2 mm) ALUMINUM

DESIGN BY: EEW
PROJECT ID: I-4413
CHECKED BY: DIV: 6
DATE: Sep 22, 2011

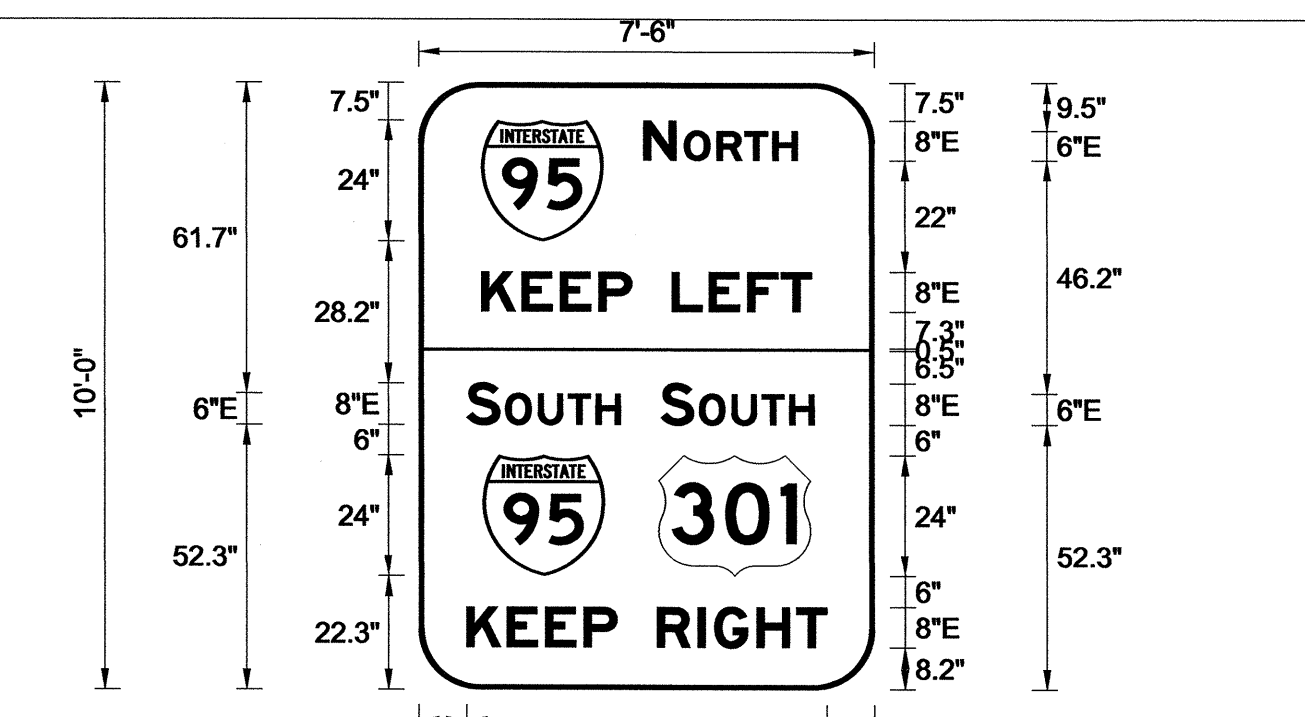

BORDER R=12" TH=1" Spacing Factor is 1 unless specified otherwise

LETTER POSITIONS

Letter spacings are to start of next letter

Series/Size	Text Length
E 2000	30.4
E 2000	65.2
E 2000	30.3
E 2000	30.3
E 2000	71.1

FILENAME: I-4413 Guidesign NORTH CAROLINA D.O.T. SIGN DETAIL

SIGN NUMBER: 107,113
TYPE: A
QUANTITY: 2
SIGN WIDTH: 16'-6"
HEIGHT: 9'-6"
TOTAL AREA: 156.8 Sq.Ft.
BORDER TYPE: FLUSH
RECESS: 0"
WIDTH: 1.5"
RADIUS: 12"
NO. Z BARS: 3
LENGTH: 190.0

BACKG COLOR: Green / Blue
COPY COLOR: White

SYMBOL	X	Y	WID	HT

MAT'L: 0.125" (3.2 mm) ALUMINUM

DESIGN BY: EEW
PROJECT ID: I-4413
CHECKED BY: DIV: 6
DATE: Mar 05, 2012

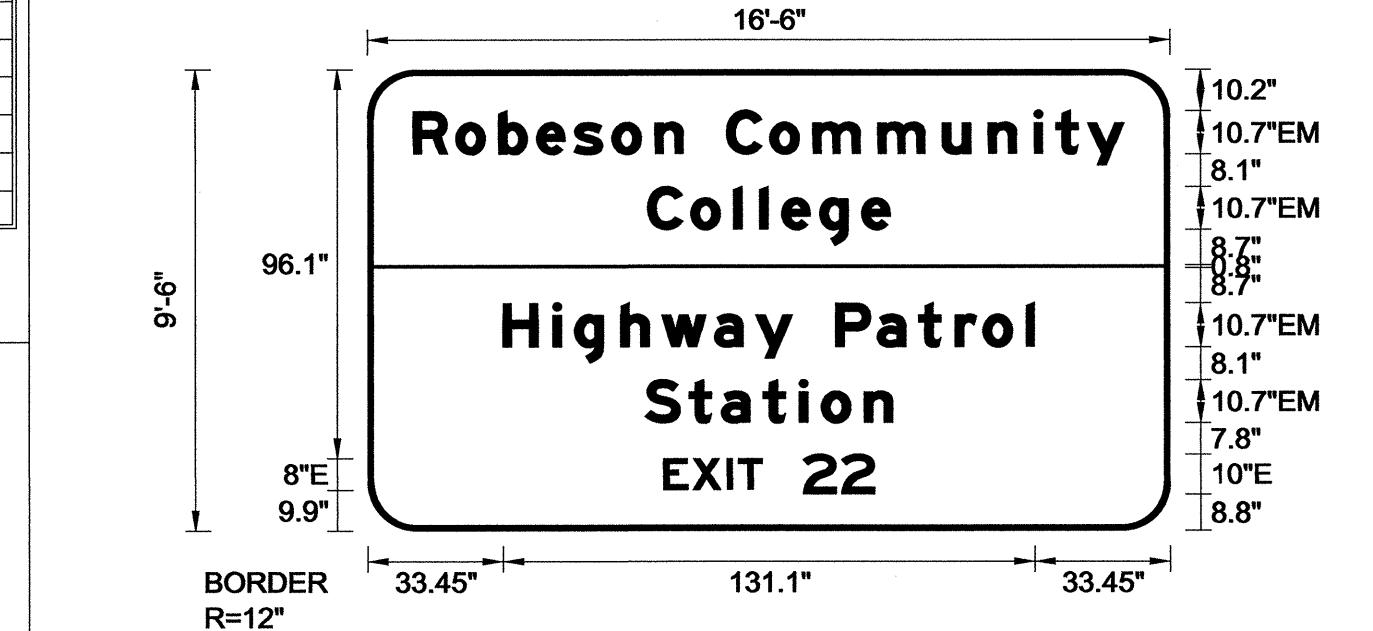

BORDER R=12" TH=1.5" Spacing Factor is 1 unless specified otherwise

LETTER POSITIONS

Letter spacings are to start of next letter

Series/Size	Text Length
EM 2000	175.4
EM 2000	59.9
EM 2000	131.1
EM 2000	61.1
E 2000	52.1

FILENAME: I-4413 Guidesign NORTH CAROLINA D.O.T. SIGN DETAIL

SIGN NUMBER: 106B
TYPE: A
QUANTITY: 1
SIGN WIDTH: 14'-0"
HEIGHT: 9'-0"
TOTAL AREA: 126.0 Sq.Ft.
BORDER TYPE: FLUSH
RECESS: 0"
WIDTH: 2"
RADIUS: 12"
NO. Z BARS: 3
LENGTH: 160.0

BACKG COLOR: Green
COPY COLOR: White

SYMBOL	X	Y	WID	HT
M1_4	61.5	61.9	45	36

MAT'L: 0.125" (3.2 mm) ALUMINUM

DESIGN BY: EEW
PROJECT ID: I-4413
CHECKED BY: DIV: 6
DATE: Oct 04, 2011

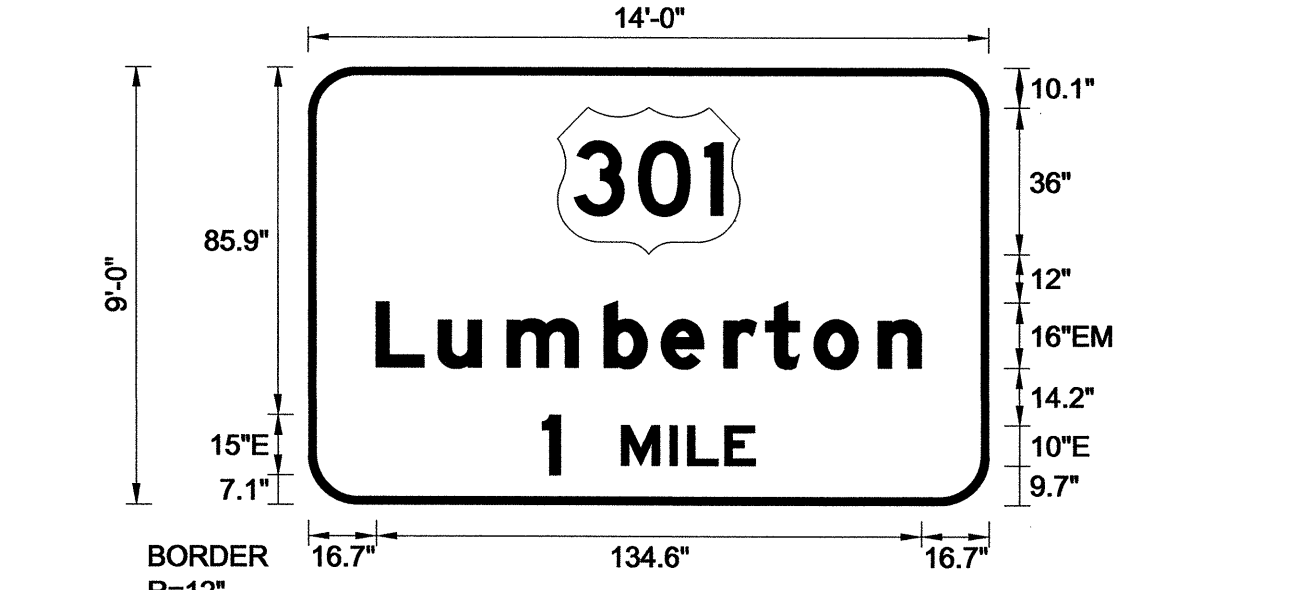

BORDER R=12" TH=2" Spacing Factor is 1 unless specified otherwise

LETTER POSITIONS

Letter spacings are to start of next letter

Series/Size	Text Length
EM 2000	134.6
E 2000	52.6

FILENAME: I-4413 Guidesign NORTH CAROLINA D.O.T. SIGN DETAIL

SIGN NUMBER: 108B
TYPE: A
QUANTITY: 1
SIGN WIDTH: 14'-0"
HEIGHT: 9'-0"
TOTAL AREA: 126.0 Sq.Ft.
BORDER TYPE: FLUSH
RECESS: 0"
WIDTH: 2"
RADIUS: 12"
NO. Z BARS: 3
LENGTH: 160.0

BACKG COLOR: Green
COPY COLOR: White

SYMBOL	X	Y	WID	HT
M1_4	61.5	61.8	45	36

MAT'L: 0.125" (3.2 mm) ALUMINUM

DESIGN BY: EEW
PROJECT ID: I-4413
CHECKED BY: DIV: 6
DATE: Sep 20, 2011

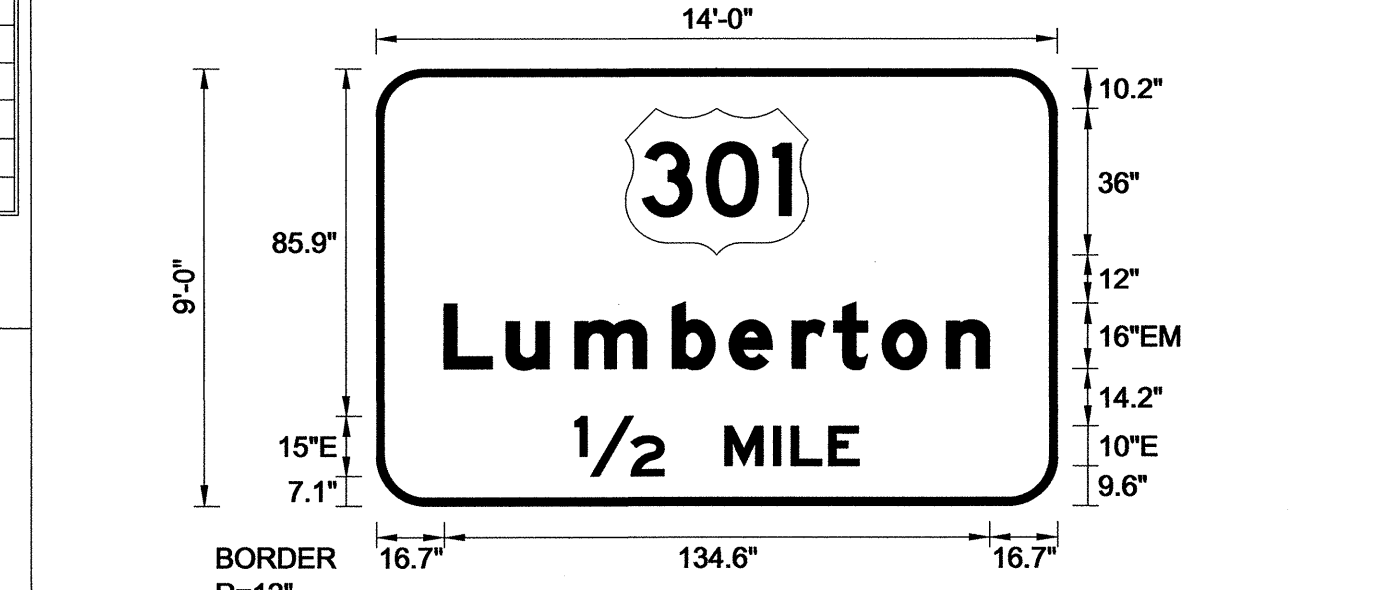

BORDER R=12" TH=2" Spacing Factor is 1 unless specified otherwise

LETTER POSITIONS

Letter spacings are to start of next letter

Series/Size	Text Length
EM 2000	134.6
E 2000	70.1

FILENAME: I-4413 Guidesign NORTH CAROLINA D.O.T. SIGN DETAIL

20-MAR-2012 10:35 P:\TIP\Projects\I-4413\Traffic\Signing\CADD\Sign Designs\I-4413 Guidesign.dgn

TYPE "A" SIGNS

TIP NO. I-4413	SHEET NO. SIGN-3E
APPROVED: <i>[Signature]</i>	
DATE: 3/29/12	
SEAL	



SIGN NUMBER: 109B TYPE: A QUANTITY: 1 SIGN WIDTH: 14'-0" HEIGHT: 10'-6" TOTAL AREA: 147.0 Sq.Ft. BORDER TYPE: FLUSH RECESS: 0" WIDTH: 2" RADII: 12" NO. Z BARS: 3 LENGTH: 160.0	BACKG COLOR: Green COPY COLOR: White SYMBOL X Y WID HT M1_4 61.5 78.7 45 36 ARMED 70.3 11.3 22.4 35.3 MATERIAL: 0.125" (3.2 mm) ALUMINUM	DESIGN BY: EEW PROJECT ID: I-4413 CHECKED BY: DIV: 6 DATE: Nov 16, 2011
--	---	--

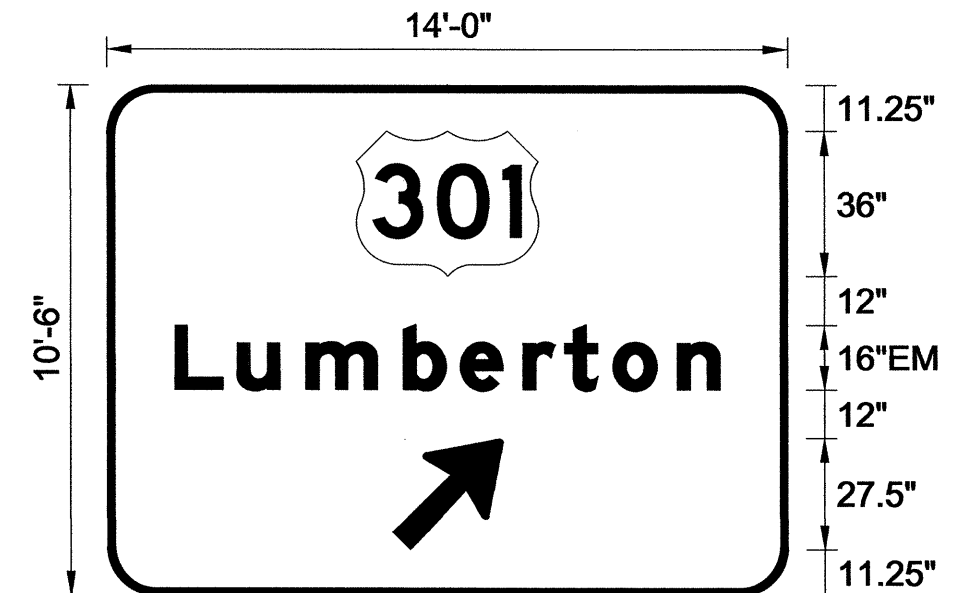

BORDER R=12" TH=2" Spacing Factor is 1 unless specified otherwise

Letter positions													Series/Size
Letter spacings are to start of next letter													Text Length
L	u	a	b	e	r	t	o	n					EM 2000
16.7	15.4	17	24	14.1	15.5	10.2	12	15.8	10.6	16.7			134.6

FILENAME: I-4413 Guidesign NORTH CAROLINA D.O.T. SIGN DETAIL

SIGN NUMBER: 201,202 TYPE: A QUANTITY: 1 SIGN WIDTH: 6'-6" HEIGHT: 5'-0" TOTAL AREA: 32.5 Sq.Ft. BORDER TYPE: FLUSH RECESS: 0" WIDTH: 1.5" RADII: 8" NO. Z BARS: 2 LENGTH: 70.0	BACKG COLOR: Green COPY COLOR: White SYMBOL X Y WID HT ARMED 49 6 18.8 29.5	DESIGN BY: EEW PROJECT ID: I-4413 CHECKED BY: DIV: 6 DATE: Mar 16, 2012
--	--	--

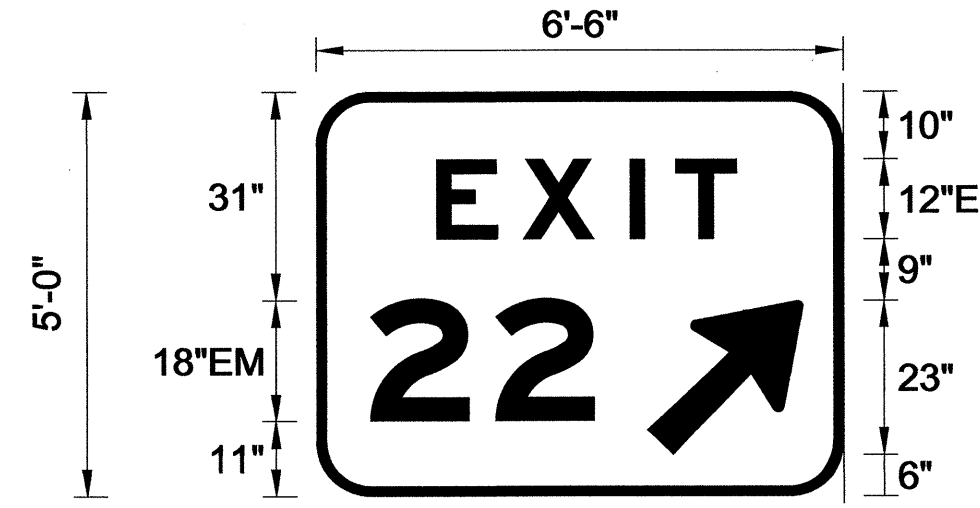

BORDER R=8" TH=1.5" Spacing Factor is 1 unless specified otherwise

Letter positions										Series/Size
Letter spacings are to start of next letter										Text Length
E	X	I	T							E 2000
17.8	12.8	15.8	6.8	9	15.8					44.4
2	2									EM 2000
8	18.5	14.6	36.9							33.1

FILENAME: I-4413 Guidesign NORTH CAROLINA D.O.T. SIGN DETAIL

SIGN NUMBER: 110 TYPE: B QUANTITY: 1 SIGN WIDTH: 11'-6" HEIGHT: 3'-6" TOTAL AREA: 40.3 Sq.Ft. BORDER TYPE: FLUSH RECESS: 0" WIDTH: 0.75" RADII: 6" NO. Z BARS: 2 LENGTH: 130.0	BACKG COLOR: Green/Green/Blue COPY COLOR: White SYMBOL X Y WID HT AR_Type D 7 31.8 6 9 AR_Type D 119.6 18 6 9 AR_Type D 111.7 4.3 6 9 MATERIAL: 0.125" (3.2 mm) ALUMINUM	DESIGN BY: EEW PROJECT ID: I-4413 CHECKED BY: DIV: 6 DATE: Mar 07, 2012
---	--	--

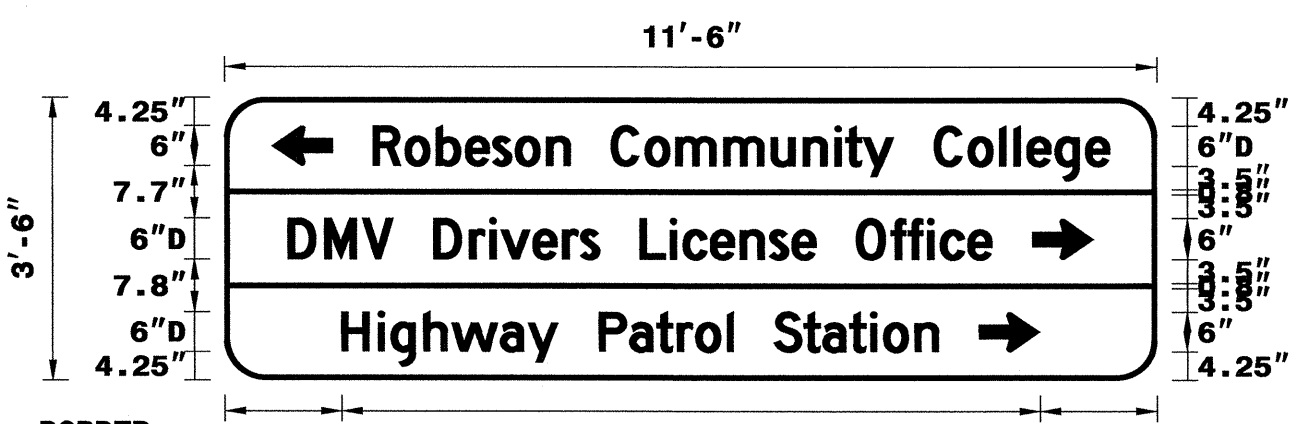

BORDER R=6" TH=0.75" Spacing Factor is 1 unless specified otherwise

Letter positions																							Series/Size					
Letter spacings are to start of next letter																							Text Length					
R	o	b	e	s	o	n	C	o	m	m	u	n	i	t	y	C	o	l	l	e	g	e	D 2000					
22	4.7	4.6	4.3	4	3.4	4.6	3.5	6	5	4.6	7.1	7	4.7	4.7	1.6	2.6	4.5	6	5	4.6	2.2	1.9	4.1	4.6	3.5	7	109.1	
D	M	V	D	r	i	v	e	r	s	L	i	c	e	n	s	e	0	f	f	i	c	e	D 2000					
9.4	5.4	5.6	4.6	6	5.3	3	1.7	4.7	4.4	2.6	2.8	6	4.5	1.9	4.1	4.4	4.3	3.4	3.5	6	5.1	2.5	2.9	1.9	4.1	3.5	24.4104.2	
H	i	g	h	w	a	y	P	a	t	r	o	l	S	t	a	t	i	o	n								D 2000	
17.3	5.4	1.9	4.8	4.2	7.2	4.1	4.5	6	4.6	4	3.1	2.8	4.6	1	6	4.4	2.8	4	3.1	1.9	4.6	3.5	32.3				88.4	

FILENAME: I-4413 Guidesign NORTH CAROLINA D.O.T. SIGN DETAIL

SIGN NUMBER: 111B TYPE: A QUANTITY: 1 SIGN WIDTH: 14'-0" HEIGHT: 10'-6" TOTAL AREA: 147.0 Sq.Ft. BORDER TYPE: FLUSH RECESS: 0" WIDTH: 2" RADII: 12" NO. Z BARS: 3 LENGTH: 160.0	BACKG COLOR: Green COPY COLOR: White SYMBOL X Y WID HT M1_4 24 78.7 45 36 ARMED 70.3 11.3 22.4 35.3 MATERIAL: 0.125" (3.2 mm) ALUMINUM	DESIGN BY: EEW PROJECT ID: I-4413 CHECKED BY: DIV: 6 DATE: Nov 16, 2011
--	---	--

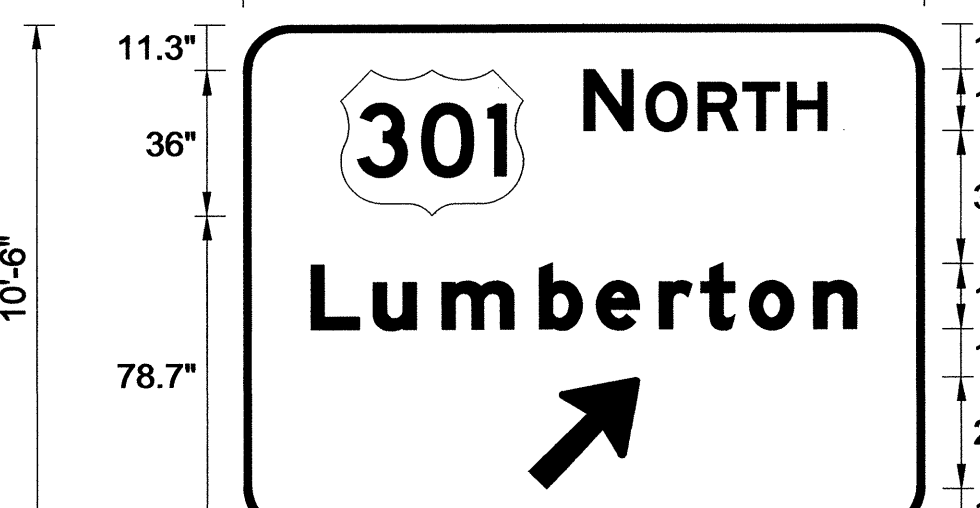

BORDER R=12" TH=2" Spacing Factor is 1 unless specified otherwise

Letter positions													Series/Size
Letter spacings are to start of next letter													Text Length
N	O	R	T	H									E 2000
84	12.2	3.1	12.8	11	11	9.7	24						59.9
L	u	a	b	e	r	t	o	n					EM 2000
16.7	15.4	17	24	14.1	15.5	10.2	12	15.8	10.6	16.7			134.6

FILENAME: I-4413 Guidesign NORTH CAROLINA D.O.T. SIGN DETAIL

TYPE "A" & "B" SIGNS

20-MAR-2012 10:36 P:\TIP\Projects\I-4413\I-af\c\Signmg\CADD\Sign Designs\I-4413 Guidesign.dgn

TIP NO. I-4413	SHEET NO. SIGN-3F
APPROVED: <i>[Signature]</i>	
DATE: 3/29/12	
SEAL	
	

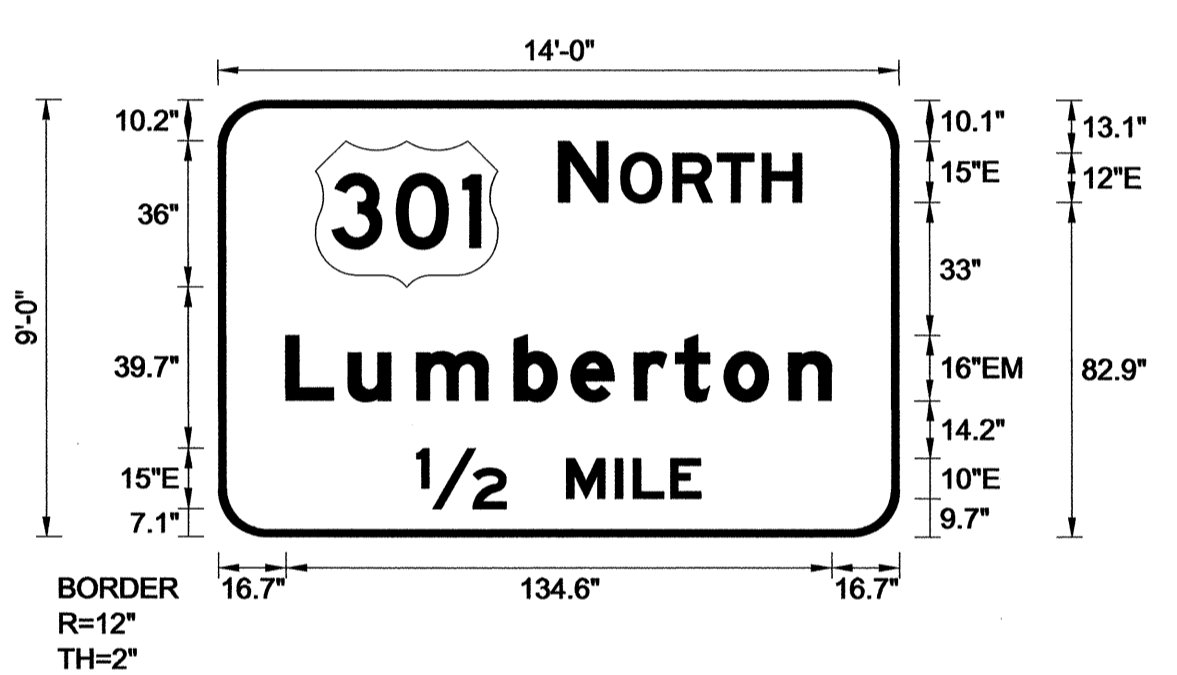
SIGN NUMBER: 112B TYPE: A QUANTITY: 1 SIGN WIDTH: 14'-0" HEIGHT: 9'-0" TOTAL AREA: 126.0 Sq.Ft. BORDER TYPE: FLUSH RECESS: 0" WIDTH: 2" RADII: 12" NO. Z BARS: 3 LENGTH: 160.0	BACKG COLOR: Green COPY COLOR: White <table border="1" style="font-size: 8px;"> <thead> <tr> <th>SYMBOL</th> <th>X</th> <th>Y</th> <th>WID</th> <th>HT</th> </tr> </thead> <tbody> <tr> <td>M1_4</td> <td>24</td> <td>61.9</td> <td>45</td> <td>36</td> </tr> </tbody> </table> MAT'L: 0.125" (3.2 mm) ALUMINUM	SYMBOL	X	Y	WID	HT	M1_4	24	61.9	45	36	DESIGN BY: EEW PROJECT ID: I-4413 CHECKED BY: DIV: 6 DATE: Oct 04, 2011	 <p style="font-size: 8px;">Spacing Factor is 1 unless specified otherwise</p>
SYMBOL	X	Y	WID	HT									
M1_4	24	61.9	45	36									

LETTER POSITIONS												Series/Size
Letter spacings are to start of next letter												Text Length
	N		O	R	T	H						E 2000
84	12.2	3.1	12.8	11	11	9.7	24					59.9
	L	u	m	b	e	r	t	o	n			EM 2000
16.7	15.4	17	24	14.1	15.5	10.2	12	15.8	10.6	16.7		134.6
	1/2		M	I	L	E						E 2000
49	22	15	12	4.4	9.2	7.5	49					70.1

FILENAME: I-4413 Guidesign NORTH CAROLINA D.O.T. SIGN DETAIL

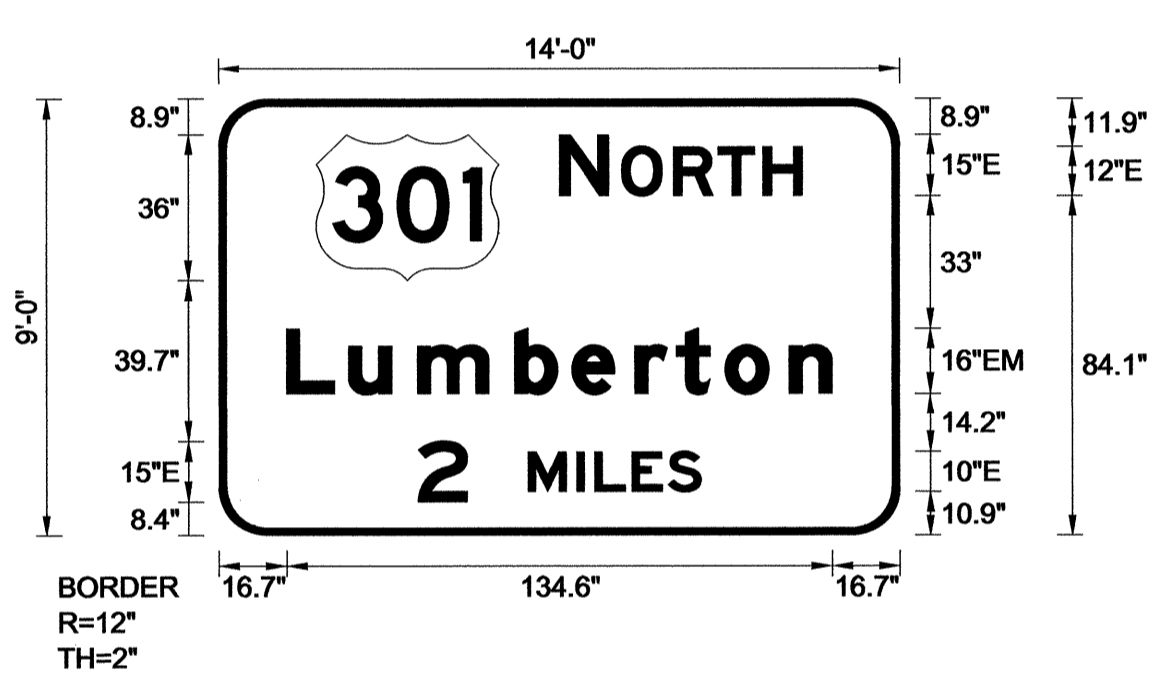
SIGN NUMBER: 114B TYPE: A QUANTITY: 1 SIGN WIDTH: 14'-0" HEIGHT: 9'-0" TOTAL AREA: 126.0 Sq.Ft. BORDER TYPE: FLUSH RECESS: 0" WIDTH: 2" RADII: 12" NO. Z BARS: 3 LENGTH: 160.0	BACKG COLOR: Green COPY COLOR: White <table border="1" style="font-size: 8px;"> <thead> <tr> <th>SYMBOL</th> <th>X</th> <th>Y</th> <th>WID</th> <th>HT</th> </tr> </thead> <tbody> <tr> <td>M1_4</td> <td>24</td> <td>63.1</td> <td>45</td> <td>36</td> </tr> </tbody> </table> MAT'L: 0.125" (3.2 mm) ALUMINUM	SYMBOL	X	Y	WID	HT	M1_4	24	63.1	45	36	DESIGN BY: EEW PROJECT ID: I-4413 CHECKED BY: DIV: 6 DATE: Oct 04, 2011	 <p style="font-size: 8px;">Spacing Factor is 1 unless specified otherwise</p>
SYMBOL	X	Y	WID	HT									
M1_4	24	63.1	45	36									

LETTER POSITIONS												Series/Size
Letter spacings are to start of next letter												Text Length
	N		O	R	T	H						E 2000
84	12.2	3.1	12.8	11	11	9.7	24					59.9
	L	u	m	b	e	r	t	o	n			EM 2000
16.7	15.4	17	24	14.1	15.5	10.2	12	15.8	10.6	16.7		134.6
	2		M	I	L	E	S					E 2000
49.1	12.2	15	12	4.4	9.2	8.9	8.1	49.1				69.8

FILENAME: I-4413 Guidesign NORTH CAROLINA D.O.T. SIGN DETAIL

20-MAR-2012 10:37 P:\TIP-projects\I-4413\I-4413-Office\Signing\CADD\Sign Designs\I-4413 Guidesign.dgn

TYPE "A" SIGNS

TIP NO. I-4413 SHEET NO. SIGN-3G

APPROVED: *[Signature]*

DATE: 3/29/12

SEAL

SIGN NUMBER: 106A,108A,109A,111A,112A,114A
 TYPE: B
 QUANTITY: 6
 SIGN WIDTH: 9'-6"
 HEIGHT: 2'-6"
 TOTAL AREA: 23.8 Sq.Ft.
 BORDER TYPE: FLUSH
 RECESS: 0"
 WIDTH: 0"
 RADII: 0"
 NO. Z BARS: 2
 LENGTH: 106.0

BACKG COLOR: Green
 COPY COLOR: Black/White
 MATERIAL: 0.125" (3.2 mm) ALUMINUM

DESIGN BY: EEW
 PROJECT ID: I-4413
 CHECKED BY:
 DIV: 6
 DATE: Mar 01, 2012

USE NOTES: 1,2

- Legend and border(except those that are colored black) shall be direct applied Grade C sheeting.
- Background shall be Grade C reflective sheeting.
- Shields; A, B, and C type arrows shall be on 0.032" (0.8mm) aluminum and demountable.

Spacing Factor is 1 unless specified otherwise

LETTER POSITIONS

Letter spacings are to start of next letter

	E	X	I	T	2	2												
21	8.9	10.7	3.5	7.5	15	14.3	12.2	21										

Series/Size Text Length
E 2000
72

FILENAME: I-4413 Guidesign NORTH CAROLINA D.O.T. SIGN DETAIL

SIGN NUMBER: 301
 TYPE: D
 QUANTITY: 1
 SIGN WIDTH: 2'-6"
 HEIGHT: 3'-6"
 TOTAL AREA: 8.8 Sq.Ft.
 BORDER TYPE: FLUSH
 RECESS: 0"
 WIDTH: 0.5"
 RADII: 3"
 NO. Z BARS:
 LENGTH:

BACKG COLOR: Green
 COPY COLOR: White
 MATERIAL: 0.125" (3.2 mm) ALUMINUM

DESIGN BY: EEW
 PROJECT ID: I-4413
 CHECKED BY:
 DIV: 6
 DATE: Nov 16, 2011

USE NOTES: 1,2

- Legend and border(except those that are colored black) shall be direct applied Grade C sheeting.
- Background shall be Grade C reflective sheeting.
- Shields; A, B, and C type arrows shall be on 0.032" (0.8mm) aluminum and demountable.

Spacing Factor is 1 unless specified otherwise

LETTER POSITIONS

Letter spacings are to start of next letter

	D	M	V															
9.8	3.6	3.7	3	9.8														
4.6	3.6	3.4	1.2	3.6	3.2	3.1	2.7	4.6										
4.7	3.1	1.5	3.6	3.2	3.4	3.4	2.5	4.7										
6.3	3.7	3.1	3.1	1.5	3.6	2.5	6.3											

Series/Size Text Length
D 2000
10.4
20.9
20.6
17.5

FILENAME: I-4413 Guidesign NORTH CAROLINA D.O.T. SIGN DETAIL

SIGN NUMBER: 302
 TYPE: D
 QUANTITY: 1
 SIGN WIDTH: 2'-6"
 HEIGHT: 3'-0"
 TOTAL AREA: 7.5 Sq.Ft.
 BORDER TYPE: FLUSH
 RECESS: 0"
 WIDTH: 0.5"
 RADII: 3"
 NO. Z BARS:
 LENGTH:

BACKG COLOR: Green
 COPY COLOR: White
 MATERIAL: 0.125" (3.2 mm) ALUMINUM

DESIGN BY: EEW
 PROJECT ID: I-4413
 CHECKED BY:
 DIV: 6
 DATE: Nov 16, 2011

USE NOTES: 1,2

- Legend and border(except those that are colored black) shall be direct applied Grade C sheeting.
- Background shall be Grade C reflective sheeting.
- Shields; A, B, and C type arrows shall be on 0.032" (0.8mm) aluminum and demountable.

MOUNTED BELOW SIGN 301

Spacing Factor is 1 unless specified otherwise

LETTER POSITIONS

Letter spacings are to start of next letter

	H	I	G	H	W	A	Y											
3.5	3.7	1.5	3.6	3.3	3.8	3.6	3.4	3.5										
5.4	3	3.6	3.1	3.3	3.7	2.5	5.4											
4.8	3	2.7	3.6	3.1	1.5	3.7	2.7	4.8										

Series/Size Text Length
D 2000
23
19.2
20.4

FILENAME: I-4413 Guidesign NORTH CAROLINA D.O.T. SIGN DETAIL

TYPE "D" SIGNS

20-MAR-2012 10:40
 P:\TIPPr-projects-I-4413\Traffic\Signing\CADD\Sign Designs\I-4413 Guidesign.dgn
 ericward

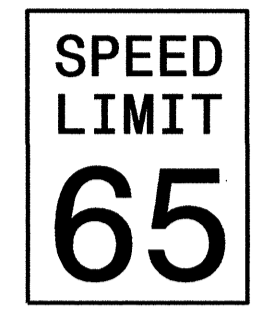
402 QUANTITY REQ'D 2
 48" X 60" R2-1
 TWO "U" POSTS PER SIGN

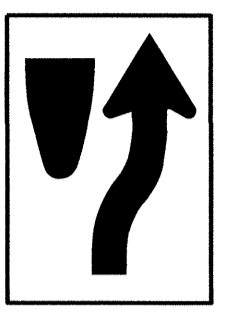
415 QUANTITY REQ'D 5
 24" X 30" R4-7
 ONE "U" POST PER SIGN

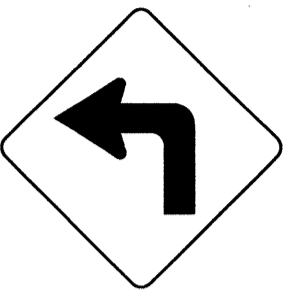
422 QUANTITY REQ'D 1
 30" X 30" W1-1L
 ONE "U" POST PER SIGN

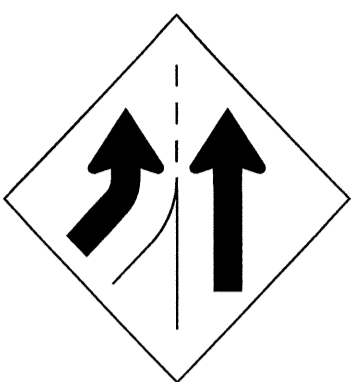
451 QUANTITY REQ'D 4
 36" X 36" W4-3(L)
 ONE "U" POST PER SIGN

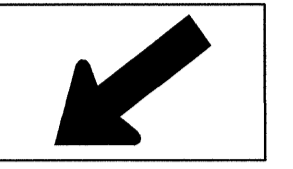
467 QUANTITY REQ'D 2
 30" X 18" W16-7P(L)
 YELLOW/GREEN REFLECTIVE SHEETING
 MOUNT BELOW SIGN 465 IN 1 INSTALLATION

403 QUANTITY REQ'D 2
 30" X 36" R2-1
 ONE "U" POST PER SIGN

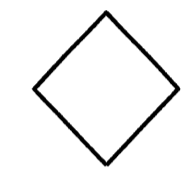
417 QUANTITY REQ'D 5
 18" X 18" OM1-3
 MOUNT BELOW SIGN 415 IN 5 INSTALLATIONS

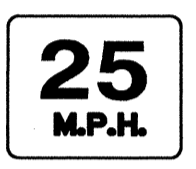
423 QUANTITY REQ'D 2
 18" X 18" W13-1P
 MOUNT BELOW SIGN 421 & 422 IN 2 INSTALLATIONS

455 QUANTITY REQ'D 2
 48" X 48" W4-1 (R)
 TWO "U" POSTS PER SIGN

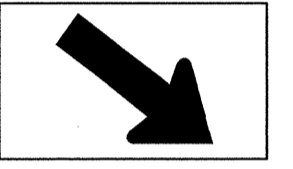
468 QUANTITY REQ'D 2
 30" X 18" W16-7P(R)
 YELLOW/GREEN REFLECTIVE SHEETING
 MOUNT BELOW SIGN 465 IN 1 INSTALLATION

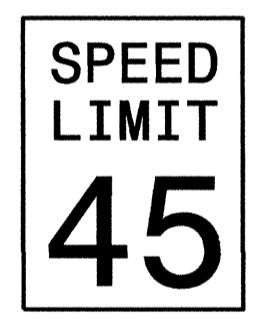
404 QUANTITY REQ'D 1
 24" X 30" R2-1
 ONE "U" POST PER SIGN

419 QUANTITY REQ'D 1
 30" X 30" W1-2R
 ONE "U" POST PER SIGN

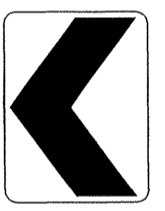
425 QUANTITY REQ'D 3
 18" X 24" W1-8(L)
 ONE "U" POST PER SIGN

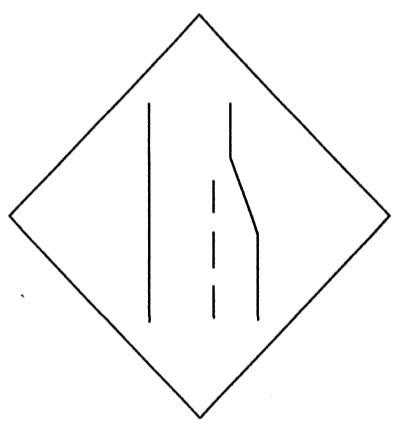
457 QUANTITY REQ'D 2
 48 X 48 W4-2(R)
 TWO "U" POSTS PER SIGN

471 QUANTITY REQ'D 3
 18" X 24" W1-8(R)
 MOUNT BACK TO BACK WITH SIGN 425 IN 3 INSTALLATIONS

407 QUANTITY REQ'D 4
 36 X 36 R5-1
 ONE "U" POST PER SIGN

420 QUANTITY REQ'D 1
 30" X 30" W1-2L
 ONE "U" POST PER SIGN

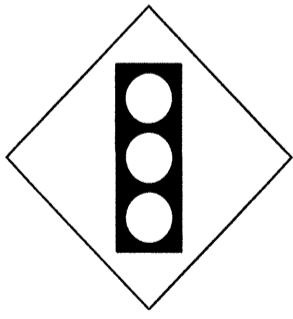
448 QUANTITY REQ'D 8
 30" X 30" W3-3
 ONE "U" POST PER SIGN

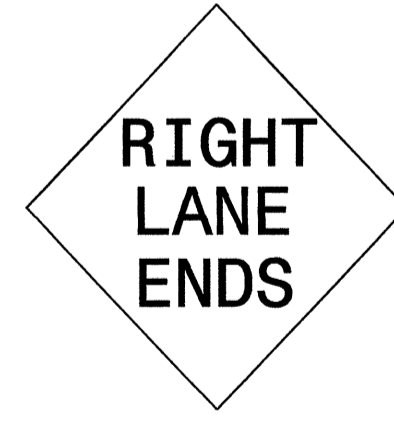
459 QUANTITY REQ'D 2
 48 X 48 W9-1(R)
 TWO "U" POSTS PER SIGN

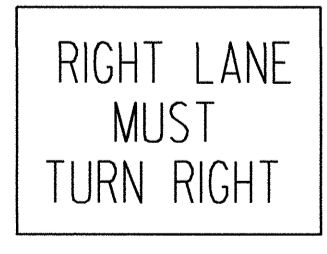
410 QUANTITY REQ'D 2
 36 X 36 R3-7
 ONE "U" POST PER SIGN

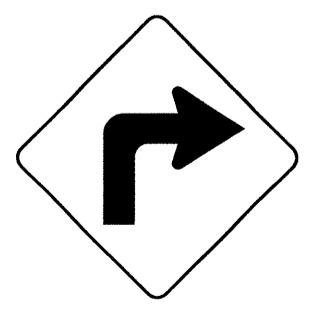
421 QUANTITY REQ'D 1
 30" X 30" W1-1R
 ONE "U" POST PER SIGN

449 QUANTITY REQ'D 4
 18" X 18" W13-1P
 MOUNT BELOW SIGN 448 IN 4 INSTALLATIONS

465 QUANTITY REQ'D 4
 36" X 36" W11-2
 YELLOW/GREEN REFLECTIVE SHEETING
 ONE "U" POST PER SIGN

TYPE "E" SIGNS

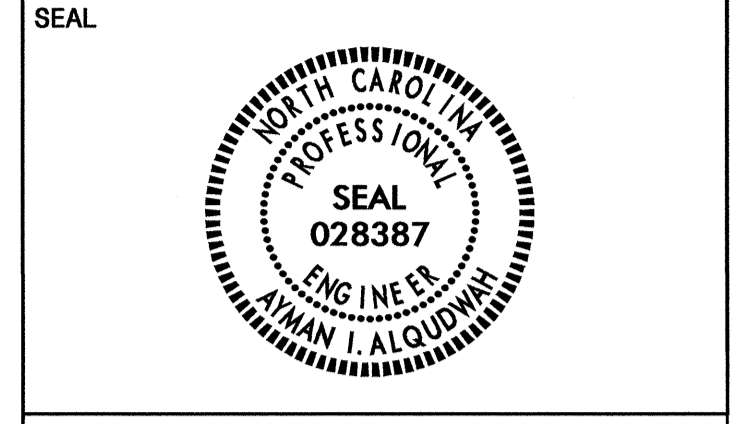

QUANTITY REQ'D - 2 -	
MILE 2 1	12" X 36"

QUANTITY REQ'D - 2 -	
MILE 2 2	12" X 36"

QUANTITY REQ'D - 2 -	
MILE 2 2	12" X 36"

QUANTITY REQ'D - 2 -	
MILE 2 2	12" X 36"

**TYPE "F" SIGNS
& MILEMARKERS**

501

TWO "U" POSTS PER SIGN

505

TWO "U" POSTS PER SIGN

502

ONE "U" POST PER SIGN

506

ONE "U" POST PER SIGN

503

TWO "U" POSTS PER SIGN

507

ONE "U" POST PER SIGN

504

ONE "U" POST PER SIGN

TIP NO. I-4413	SHEET NO. SIGN-4
APPROVED: <i>[Signature]</i>	
DATE: 3/29/12	
SEAL	



SEAL
028387
ENGINEER
KAWAN I. ALQODWAH

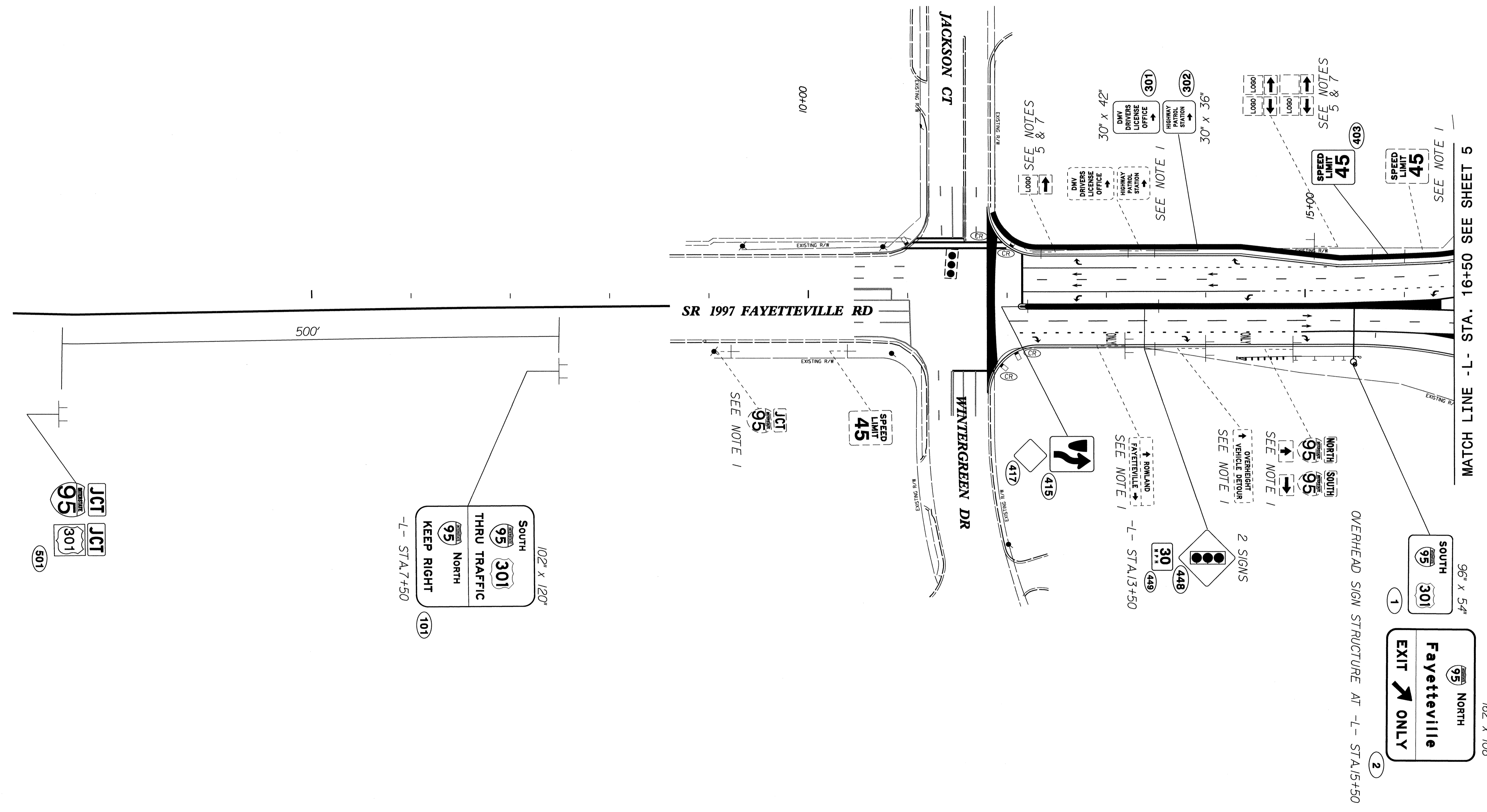
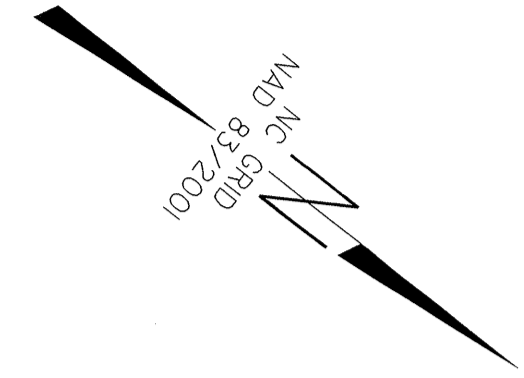

MATCH LINE -L- STA. 16+50 SEE SHEET 5

SIGNING DETAIL

20-MAR-2012 10:48
 P:\TIP\p\ec\1-4413\Traffic\Signing\CADD\Signing Layout Plans\4413_sgn_psh4.dgn
 ericward - PL TE247905

TIP NO.	SHEET NO.
I-4413	SIGN-5
APPROVED: <i>[Signature]</i>	
DATE: 3/29/12	
SEAL	

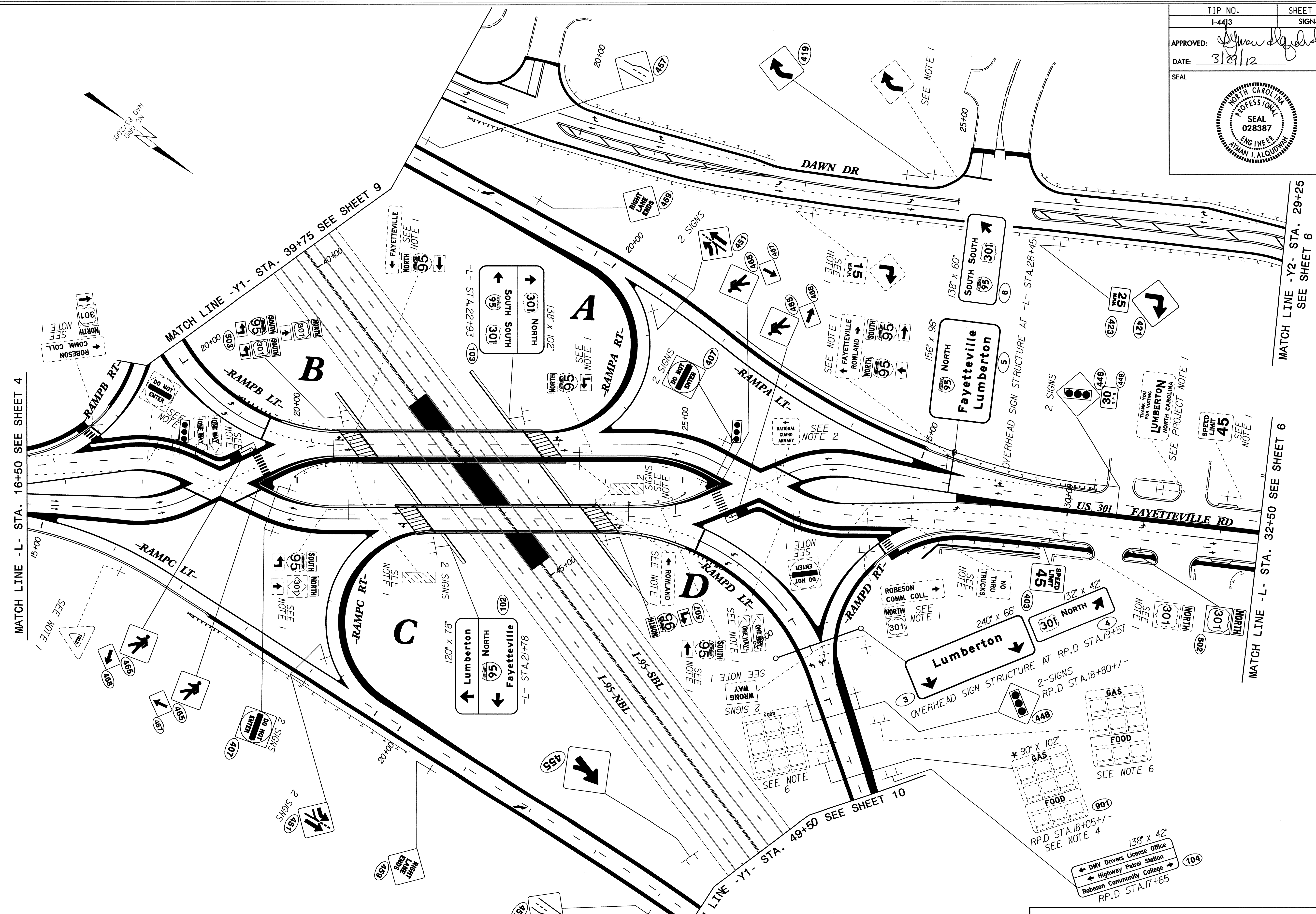

SIGNING DETAIL

26-MAR-2012 15:44
 P:\TIP\proj\14413\Traffic\CADD\Signing\Layout\Plans\4413_sgn-ph5.dgn
 ericward AT 12/27/05

TIP NO. I-4413	SHEET NO. SIGN-4
APPROVED: <i>[Signature]</i>	
DATE: 3/29/12	
SEAL	



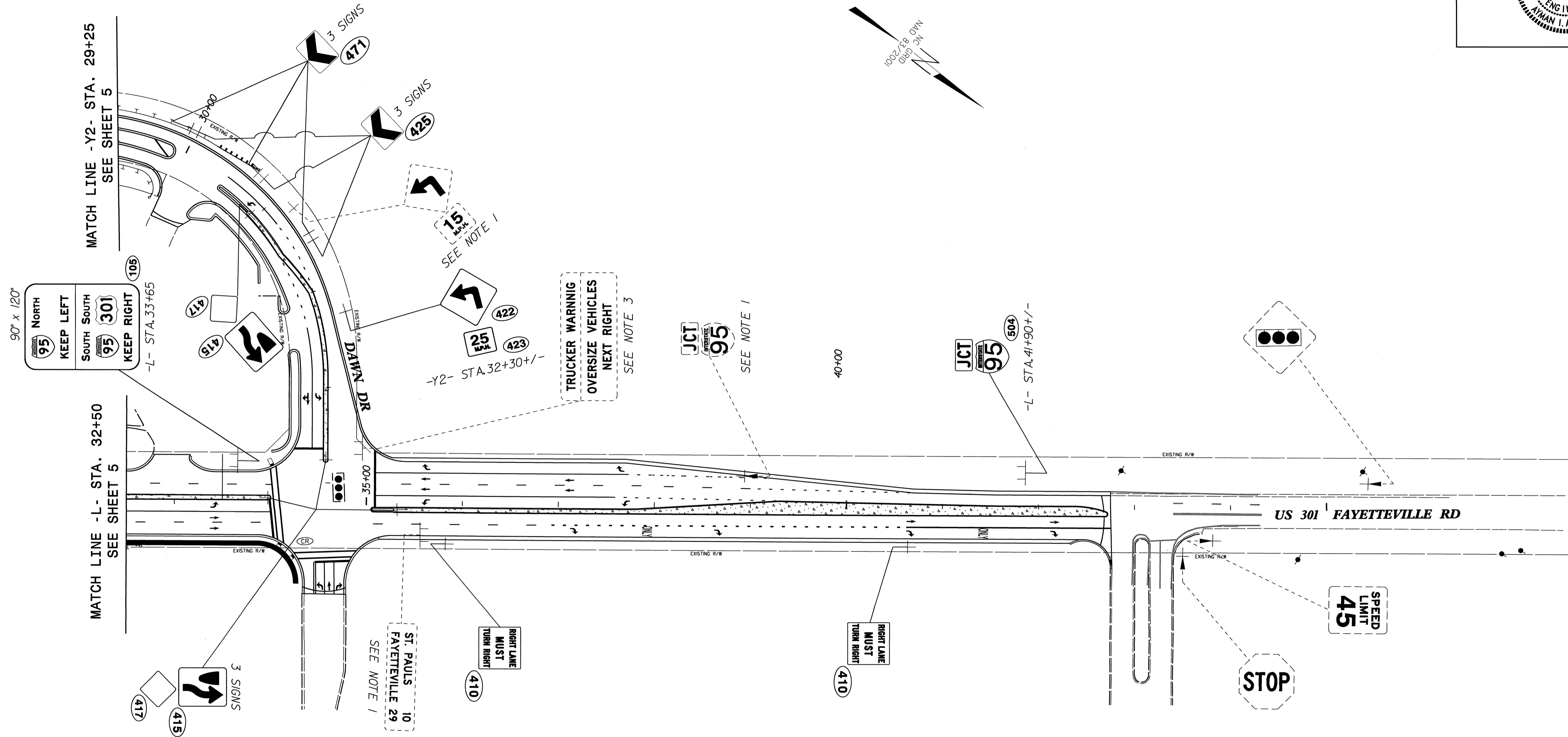

SIGNING DETAIL

TIP NO. I-4413	SHEET NO. SIGN-7
APPROVED: <i>[Signature]</i>	
DATE: 3/29/12	
SEAL	

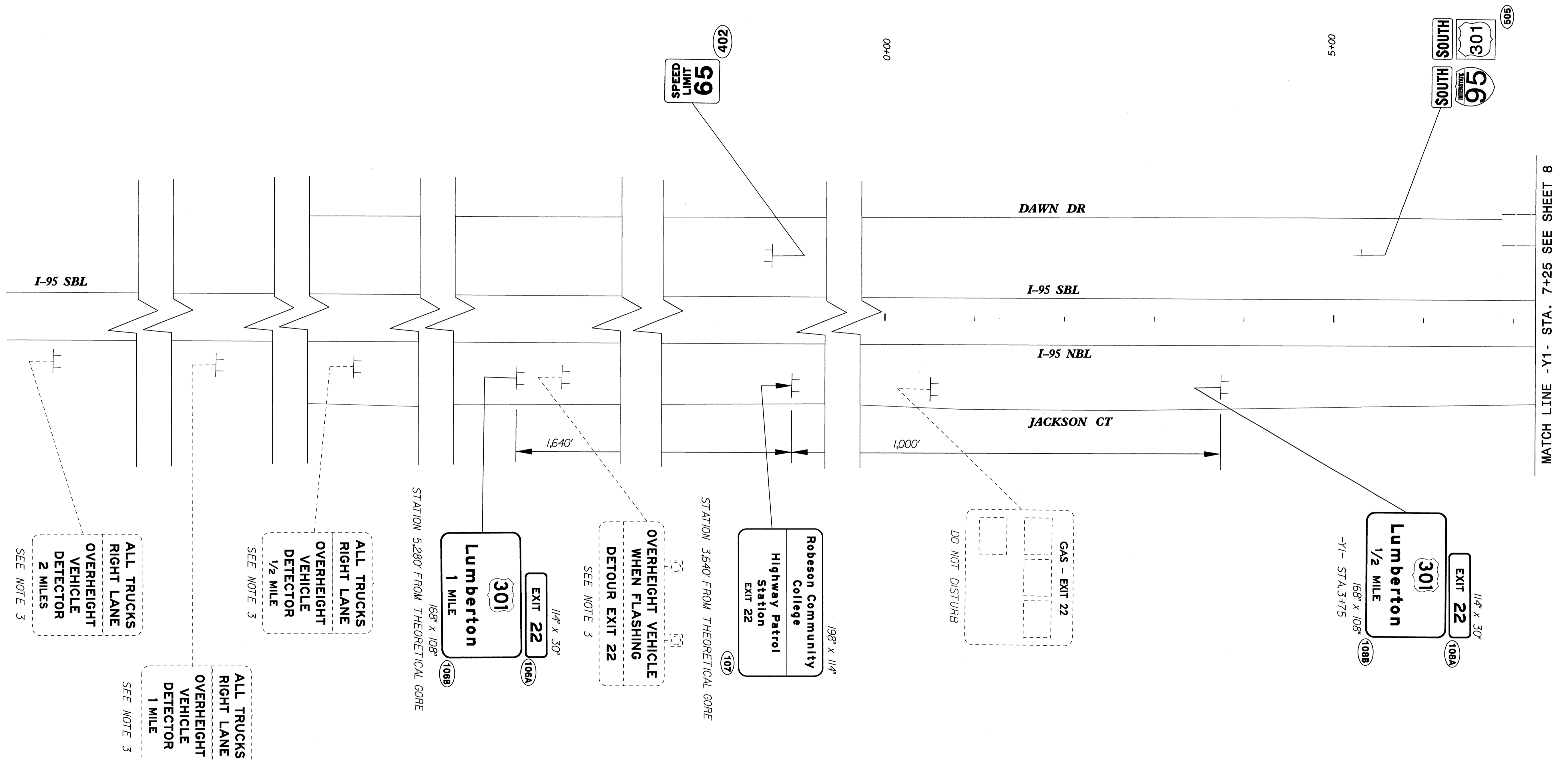
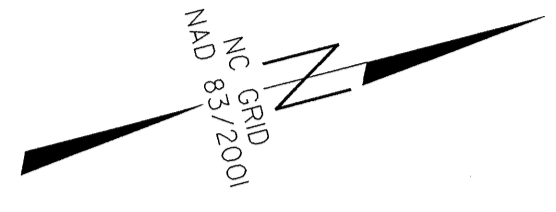

MATCH LINE -Y1- STA. 7+25 SEE SHEET 8

SIGNING DETAIL

20-MAR-2012 10:57
 P:\TIP\Projects\I-4413\I-4413-CADD\Signing Layout Plans\I-4413-sgn-ph7.dgn
 created AT 12:27:05

TIP NO. I-4413	SHEET NO. SIGN-8
APPROVED: <i>[Signature]</i>	
DATE: 3/29/12	
SEAL	
	

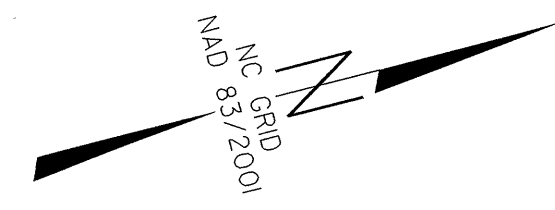

MATCH LINE -Y1- STA. 7+25 SEE SHEET 7

MATCH LINE -Y1- STA. 23+50 SEE SHEET 9

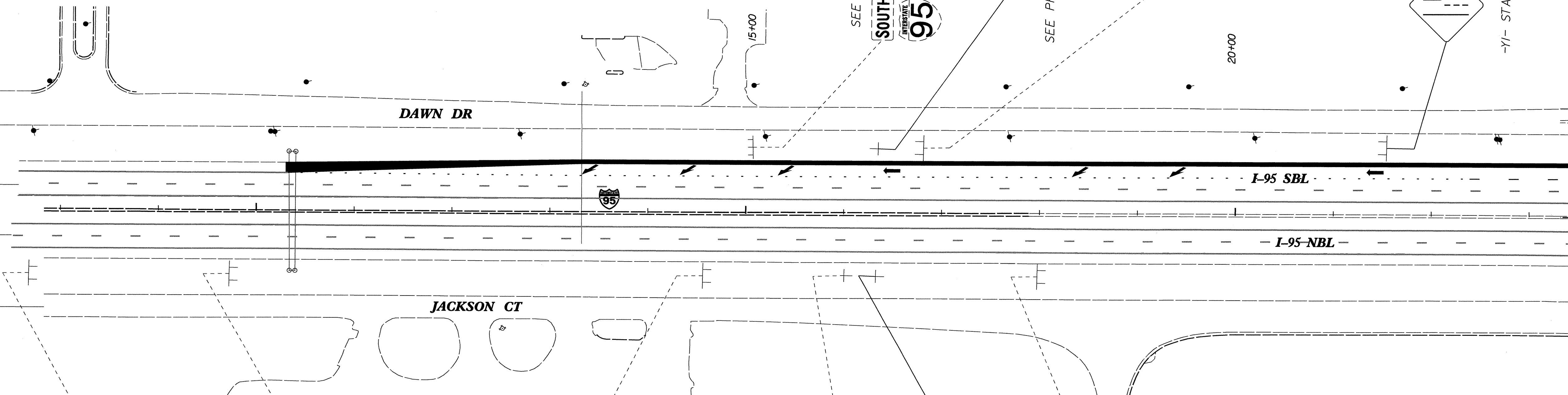

EXIT 22
OVERHEIGHT VEHICLE DETOUR
Local Traffic
301
1/2 MILE
SEE NOTE 3

Highway Patrol
Station
EXIT 22
SEE NOTE 3

SEE NOTE 1
14-6
SEE NOTE 1

SEE NOTE 1
2 1
SEE NOTE 1

SEE PROJECT NOTE 2
2 1
SEE PROJECT NOTE 2

SEE NOTE 3
EXIT 22
Robeson Comm Coll
SEE NOTE 3

FOOD - EXIT 20

SIGNING DETAIL

TIP NO. I-4413	SHEET NO. SIGN-9
APPROVED: <i>[Signature]</i>	
DATE: 3/29/12	
SEAL	

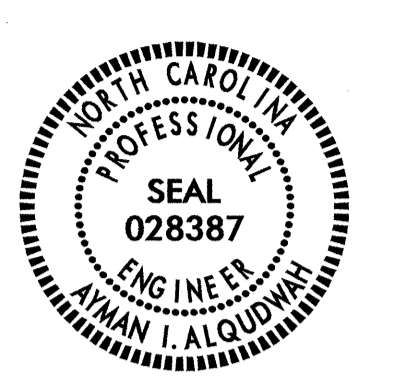

MATCH LINE -Y1- STA. 23+50 SEE SHEET 8

MATCH LINE -Y1- STA. 39+75 SEE SHEET 5

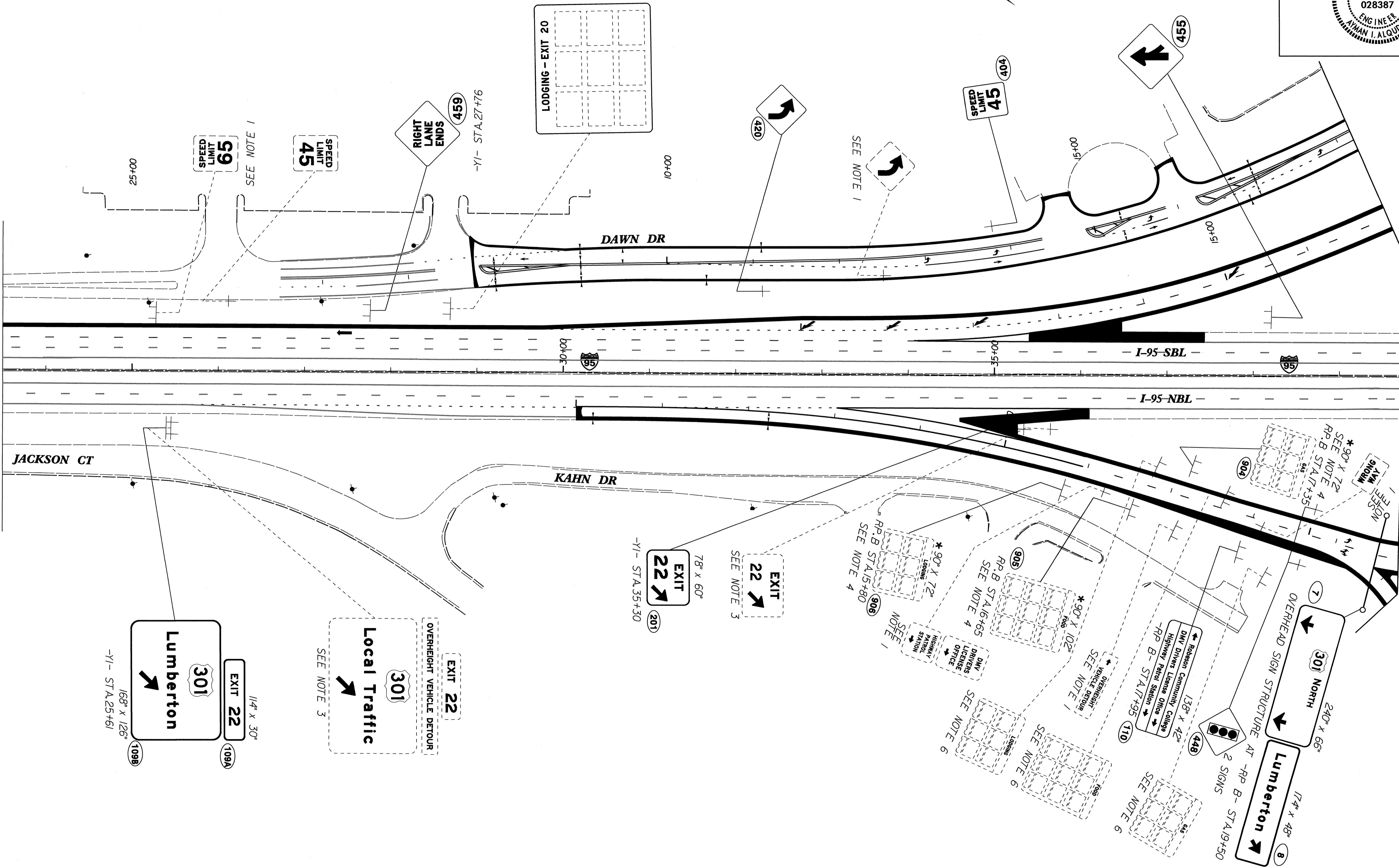

SIGNING DETAIL

20-MAR-2012 11:03
 P:\TIPR\Projects\I-4413\Traffic\Signing\CADD\Signing Layout Plans\4413_sgn_psh3.dgn
 ericward - AT 1E247905

TIP NO. I-4413	SHEET NO. SIGN-10
APPROVED: <i>[Signature]</i>	
DATE: 3/29/12	
SEAL	
	

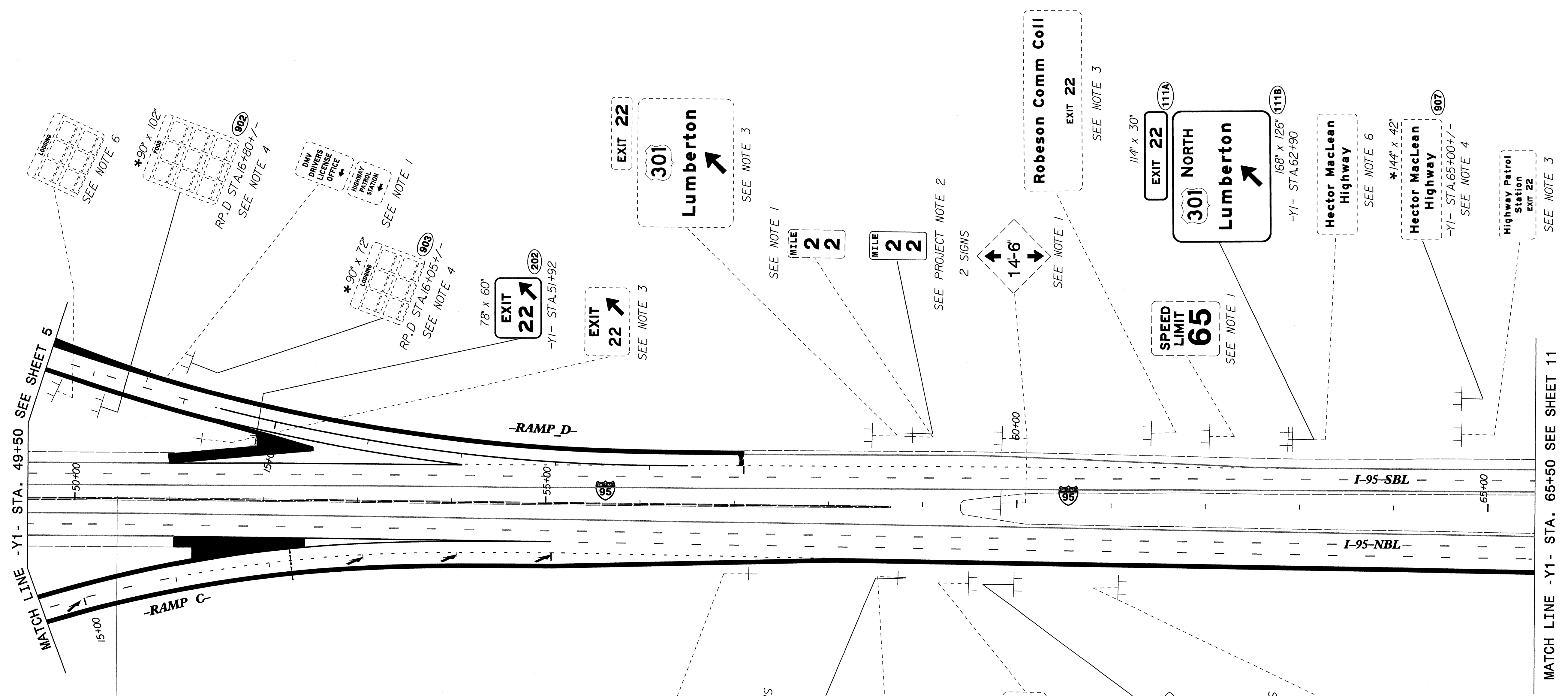
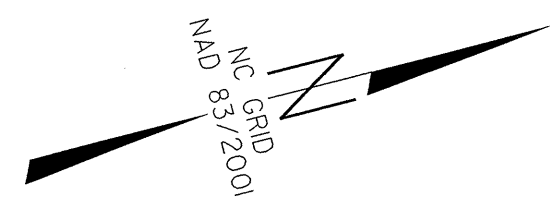

SIGNING DETAIL

20-MAR-2012 11:05
 P:\TIP\Projects\14413\Traffic\Signing\CADD\Signing Layout Plans\14413_sgn_psh10.dgn
 erickward - AT 1E247505

TIP NO. I-4413	SHEET NO. SIGN-TI
APPROVED: <i>[Signature]</i>	
DATE: 3/29/12	
SEAL	

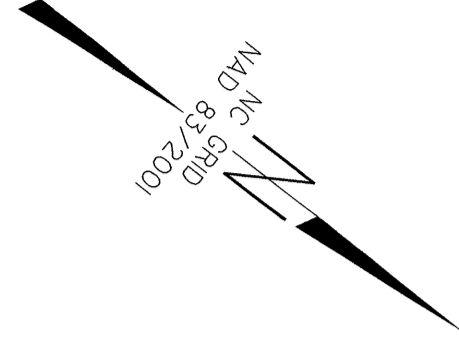

MATCH LINE -Y1- STA. 65+50 SEE SHEET 10

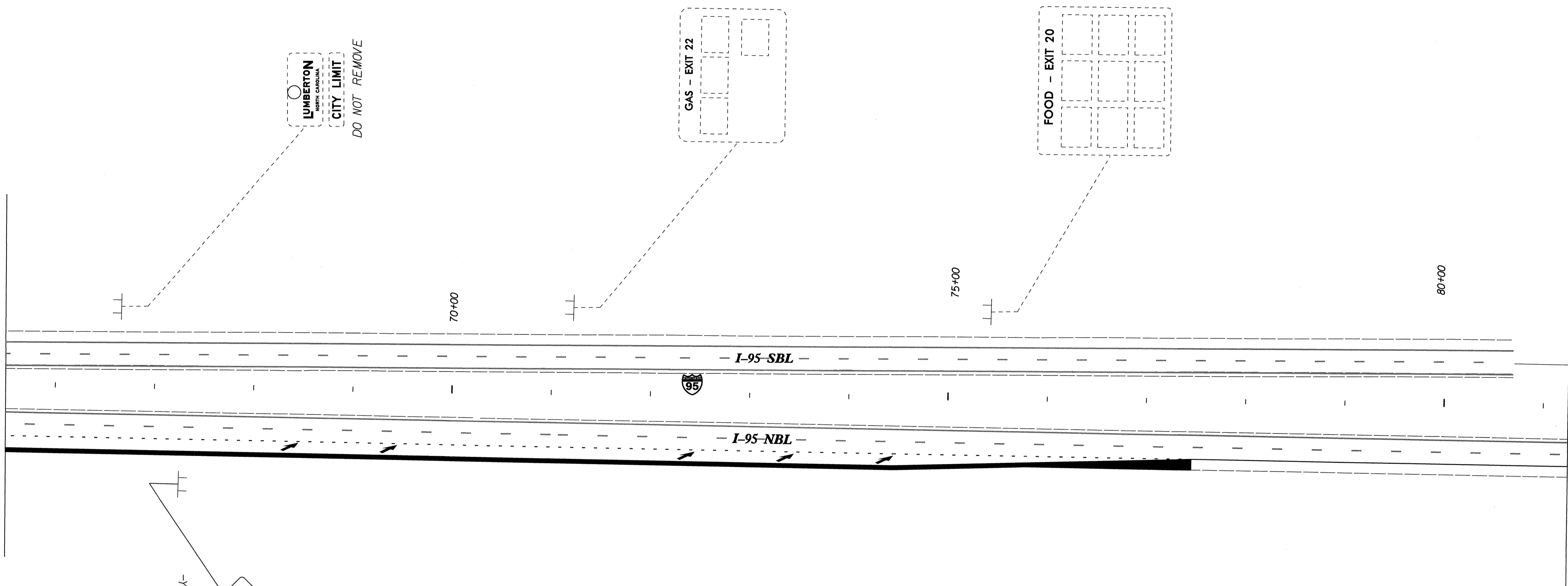

MATCH LINE -Y1- STA. 81+25 SEE SHEET 12

SIGNING DETAIL

TIP NO. I-4413	SHEET NO. SIGN-12
APPROVED: <i>[Signature]</i>	
DATE: 5/29/12	
SEAL	
	

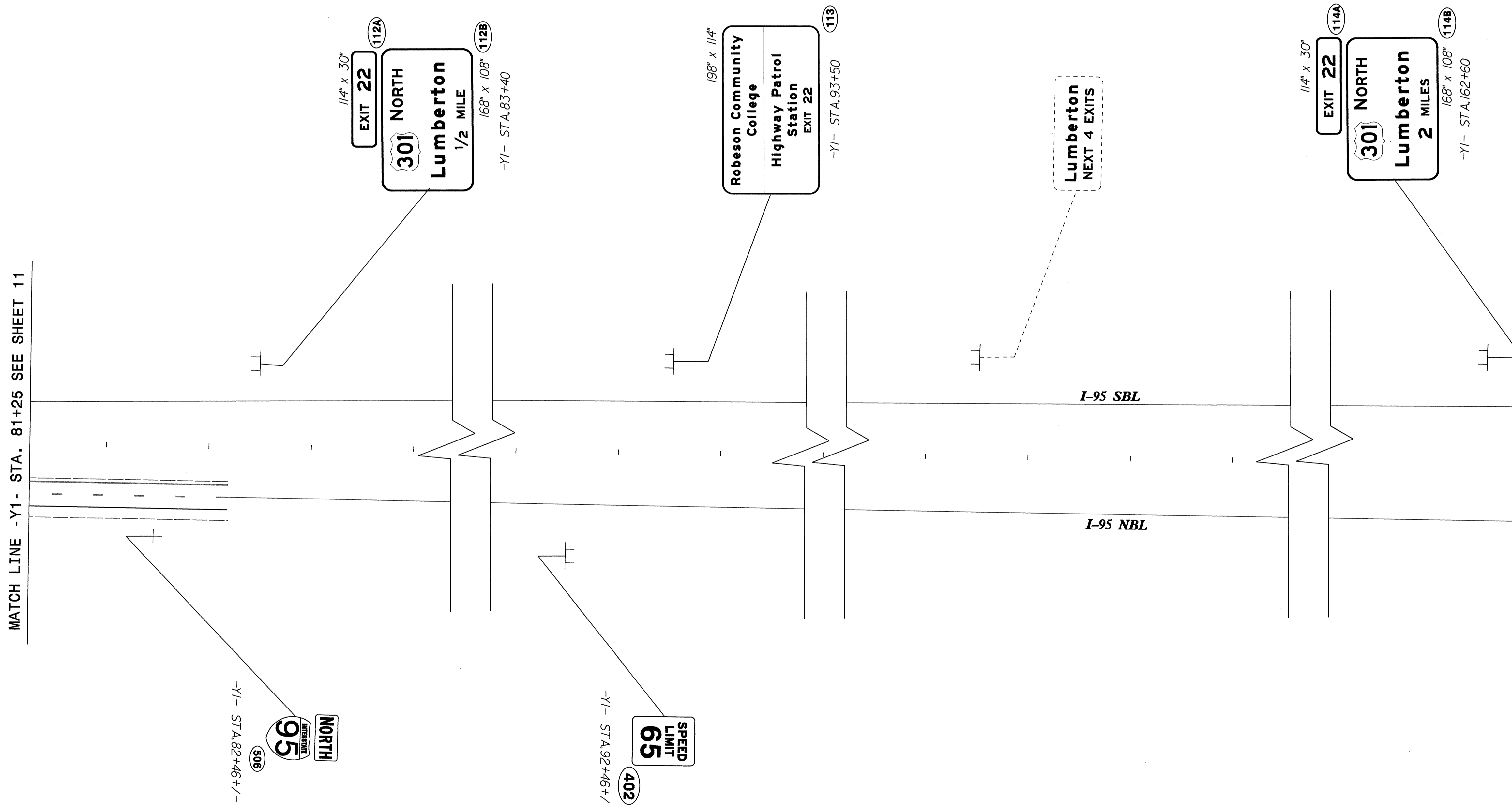
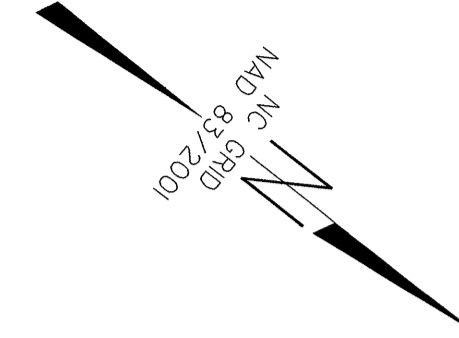

SIGNING DETAIL

20-MAR-2012 11:09
 P:\TIP\Project\14413\I-office\Signing\CADD\Signing Layout Plans\14413_sgn_pah12.dgn
 ericward AT 1E247905