

PROJECT REFERENCE NO.	SHEET NO.
9CR.10341.130, 9CR.20341.130	1

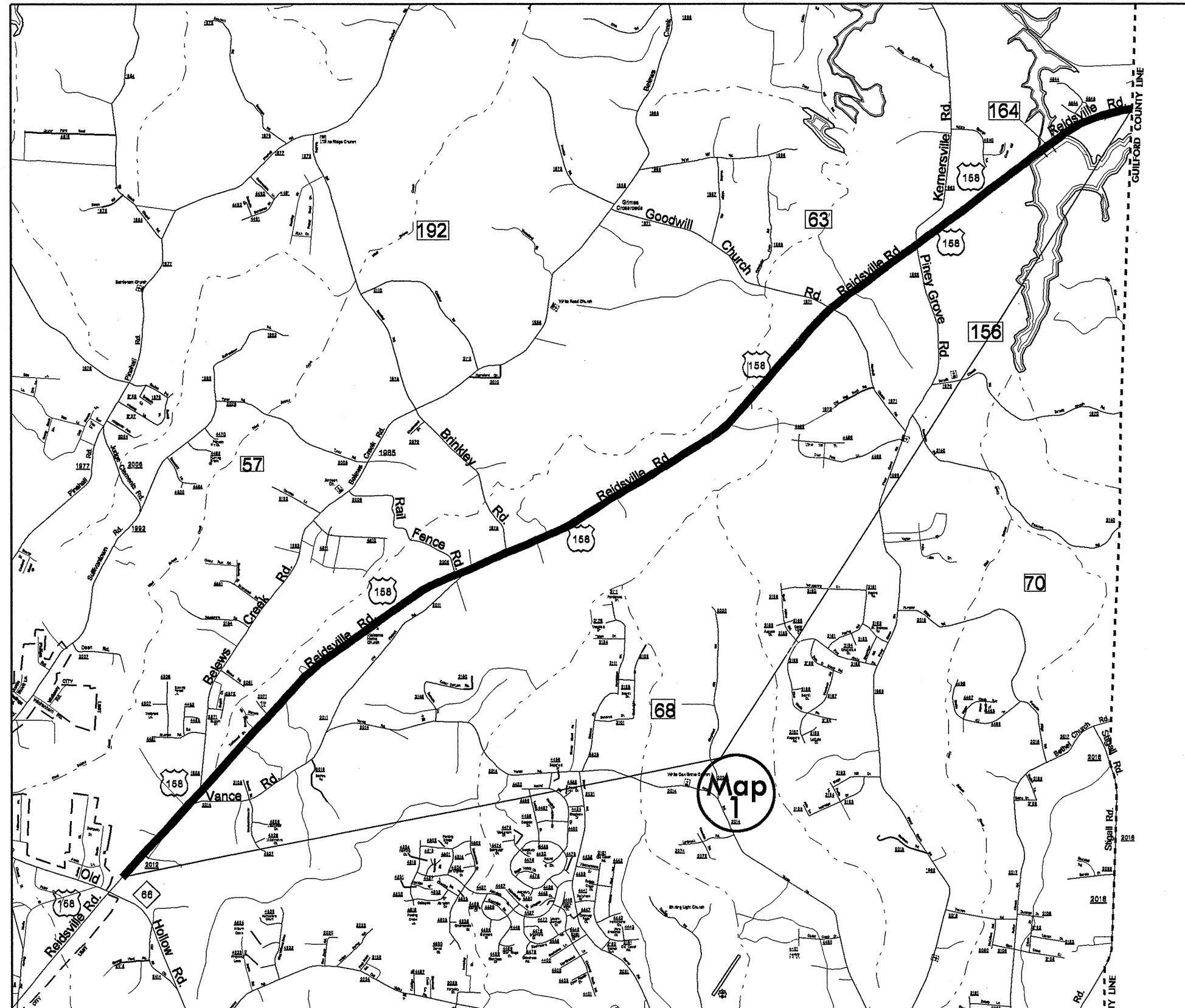

MAP NO. 1  
 US 158  
 All Patching done by state forces.

**FORSYTH COUNTY**  
 NORTH CAROLINA

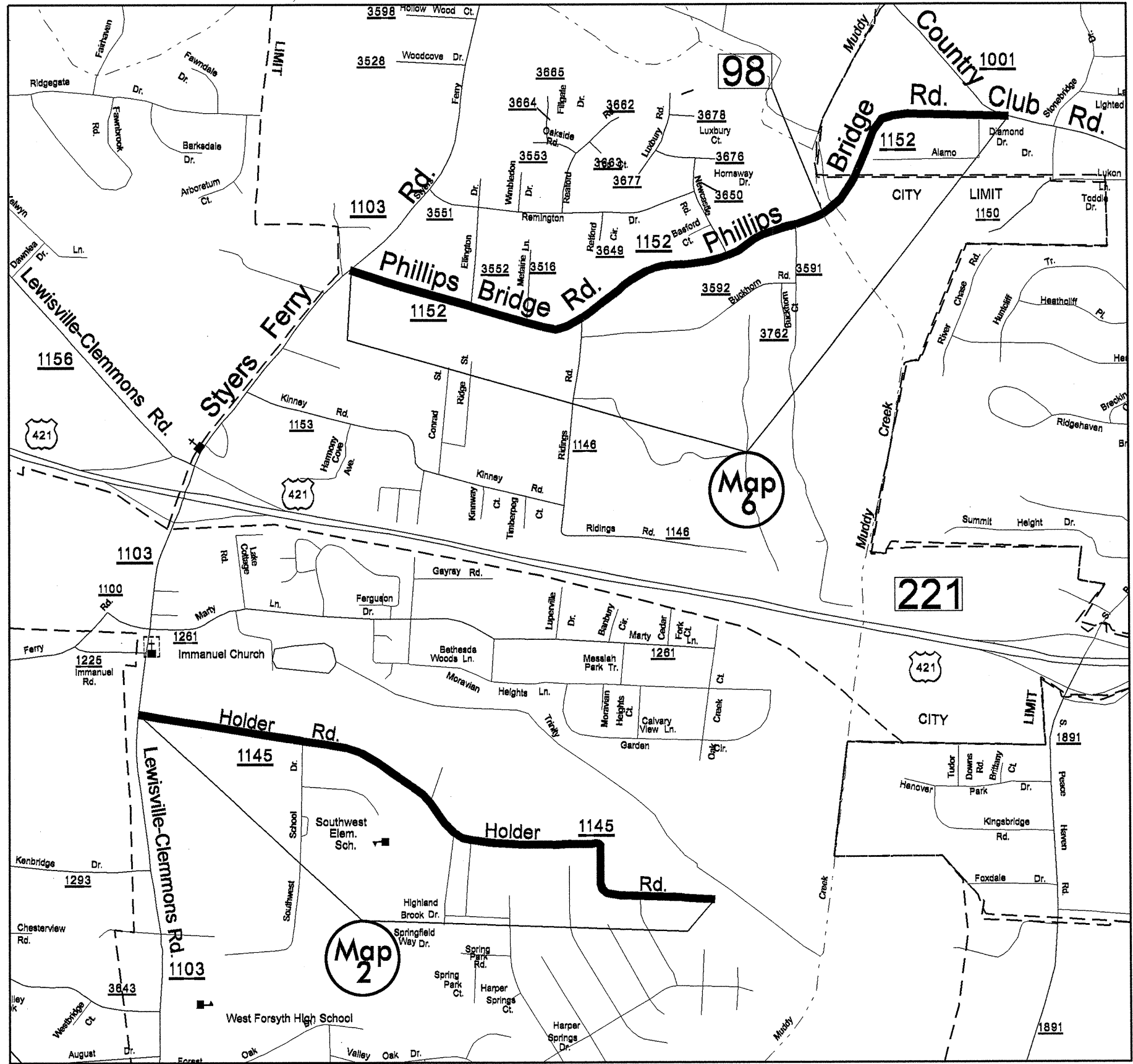

**MAP NO. 2**  
**HOLDER ROAD**  
All Patching done by state forces.

**MAP NO. 6**  
**PHILLIPS BRIDGE ROAD**  
All Patching done by state forces.

**FORSYTH COUNTY**  
NORTH CAROLINA

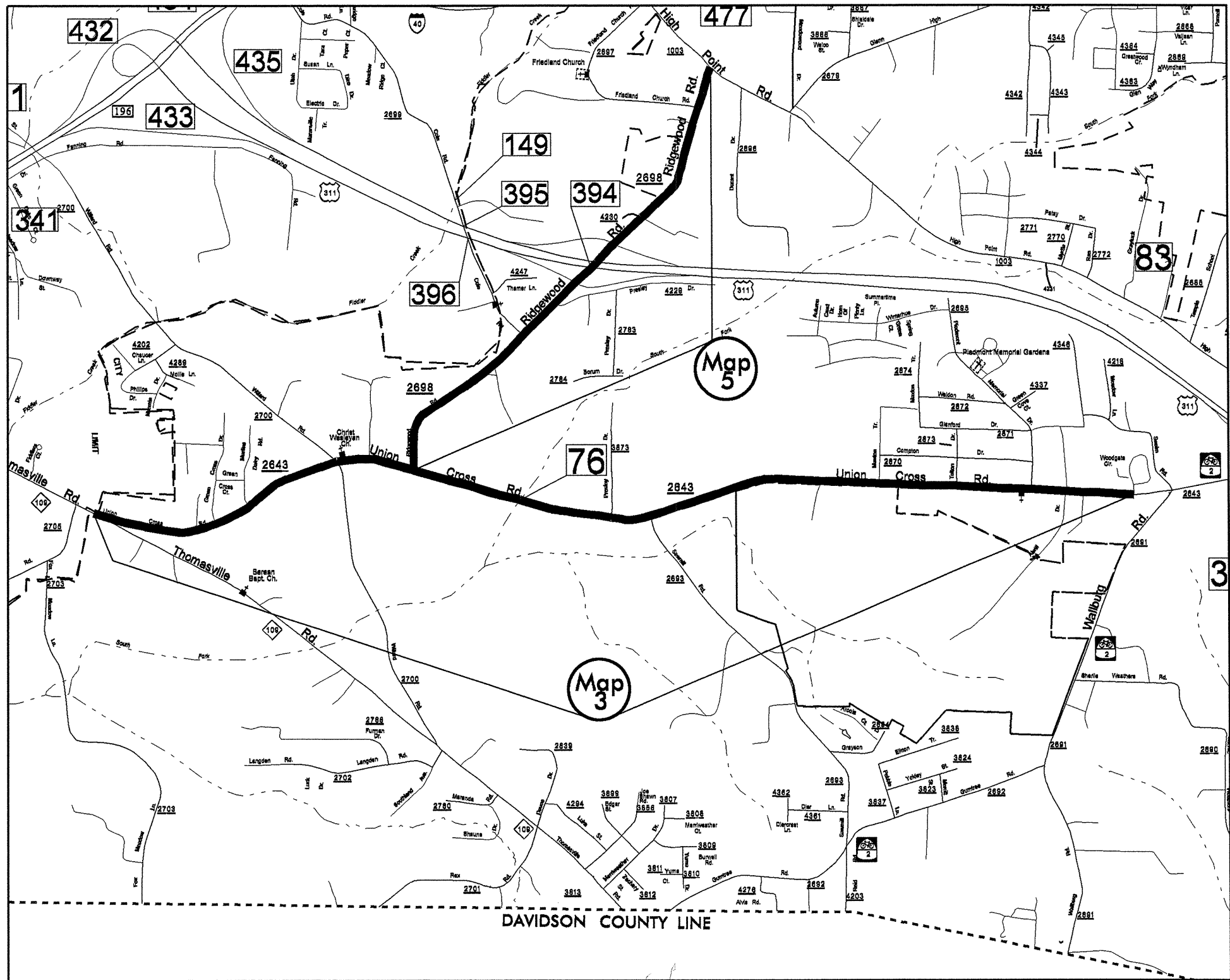

**MAP NO. 3**  
**UNION CROSS ROAD**  
 All Patching done by state forces.

**MAP NO. 5**  
**RIDGEWOOD ROAD**  
 Butt Mill Tie-in to High Point Road.  
 Tie into new resurfacing at Union Cross Road.  
 All Patching done by state forces.

**FORSYTH COUNTY**  
 NORTH CAROLINA

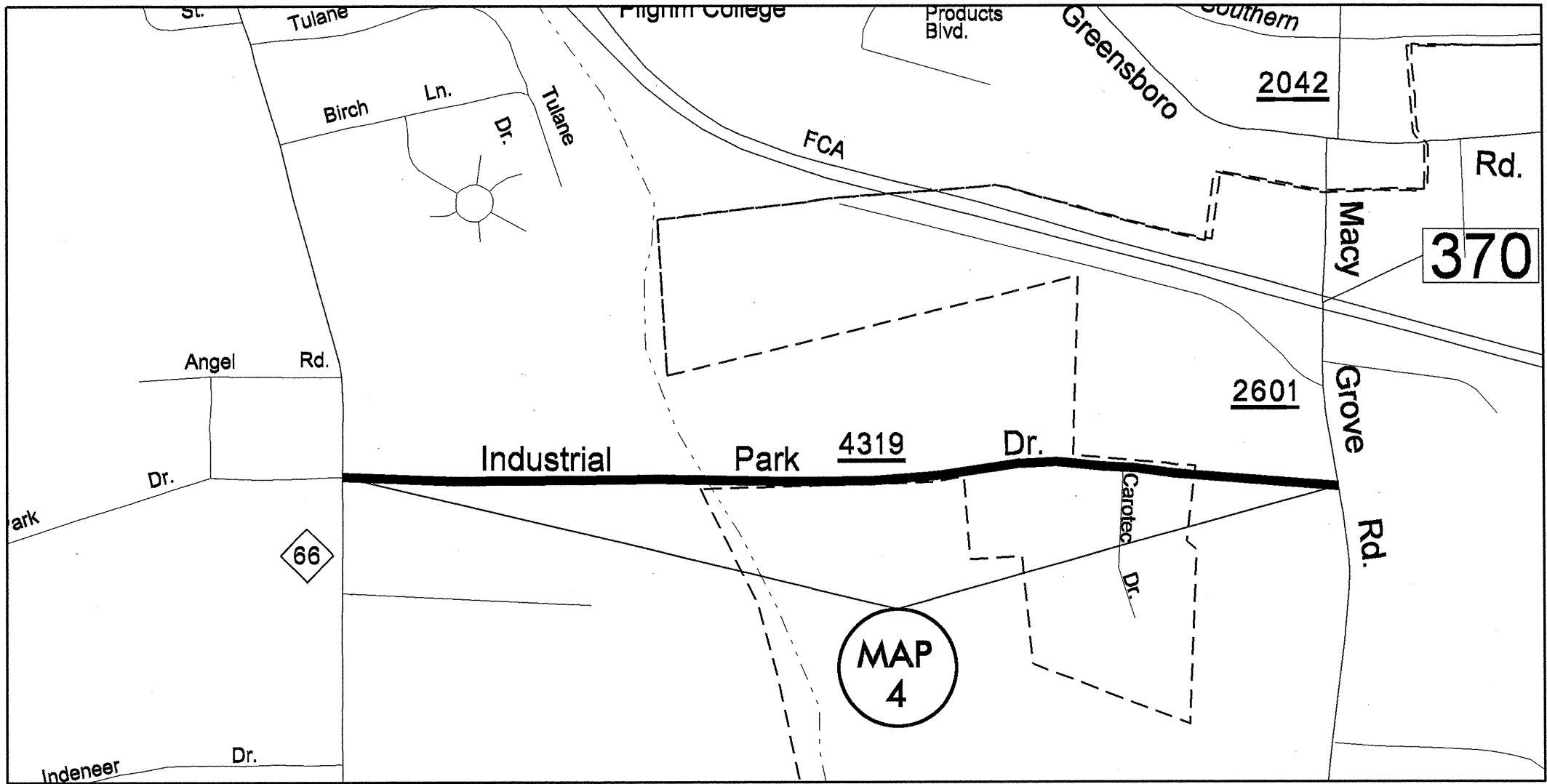

NOTE:  
MAP NO. 4  
INDUSTRIAL PARK DRIVE  
Mill 1½" to 3" depth full width of  
pavement for 950 feet beginning  
APPROX. 975 FEET from NC 66  
intersection.  
All Patching done by state forces.

**FORSYTH COUNTY**  
NORTH CAROLINA

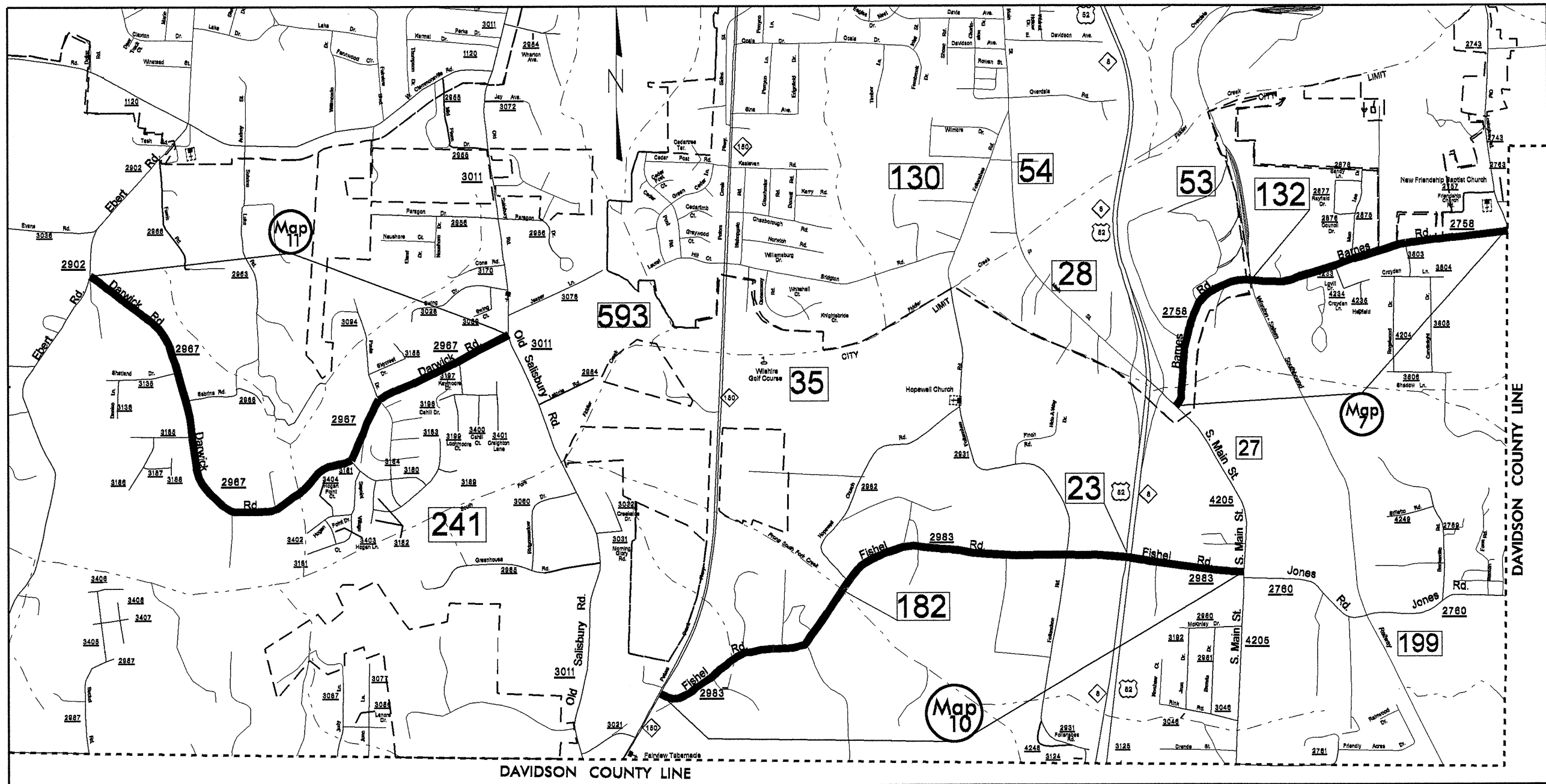

**MAP NO. 7 BARNES ROAD**  
All Patching done by state forces.

**MAP NO. 10 FISHEL ROAD**  
All Patching done by state forces.

**MAP NO. 11 DARWICK ROAD**  
All Patching done by state forces.

**FORSYTH COUNTY**  
NORTH CAROLINA

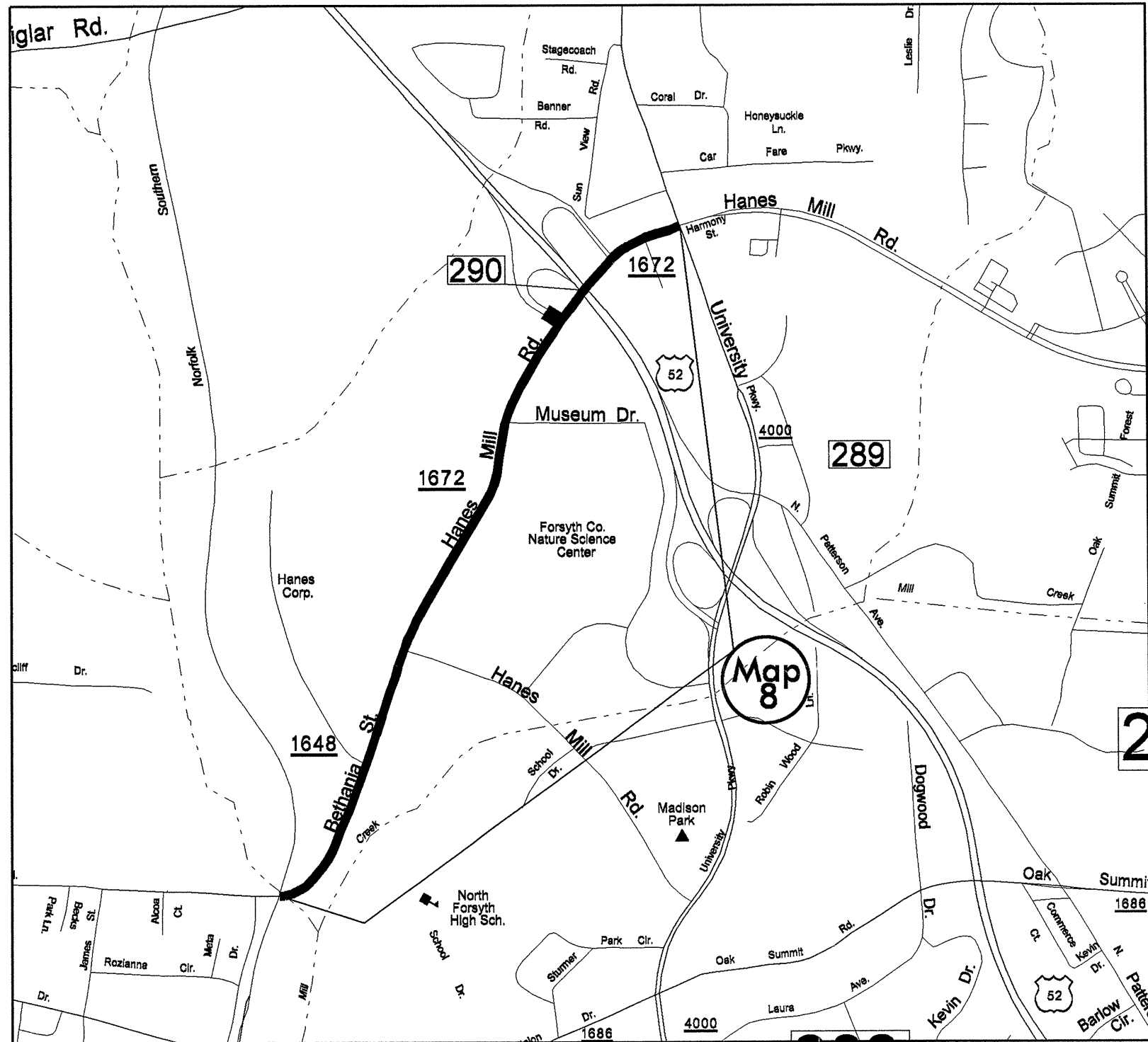

**NOTE:**  
**MAP NO. 8**  
 SEE DETAILS ON SHT. NO.10 FOR MILLING DIRECTIONS AT CARWASH.

Curb Mill 0-3" depth from Museum Drive to curb end near bridge for approx 950 feet in NORTHBOUND LANE ONLY.

Incidental Milling: Tie-in mill 0-1½" and Pave back Southbound US 52 ramps ONLY.

AT NORTHBOUND US 52 RAMPS MILL TO CREATE A BUTT JT FOR A SMOOTH TRANSITION TO TIE IN TO EDGE OF PAVEMENT OF WEST HANES MILL RD

**FORSYTH COUNTY**  
 NORTH CAROLINA

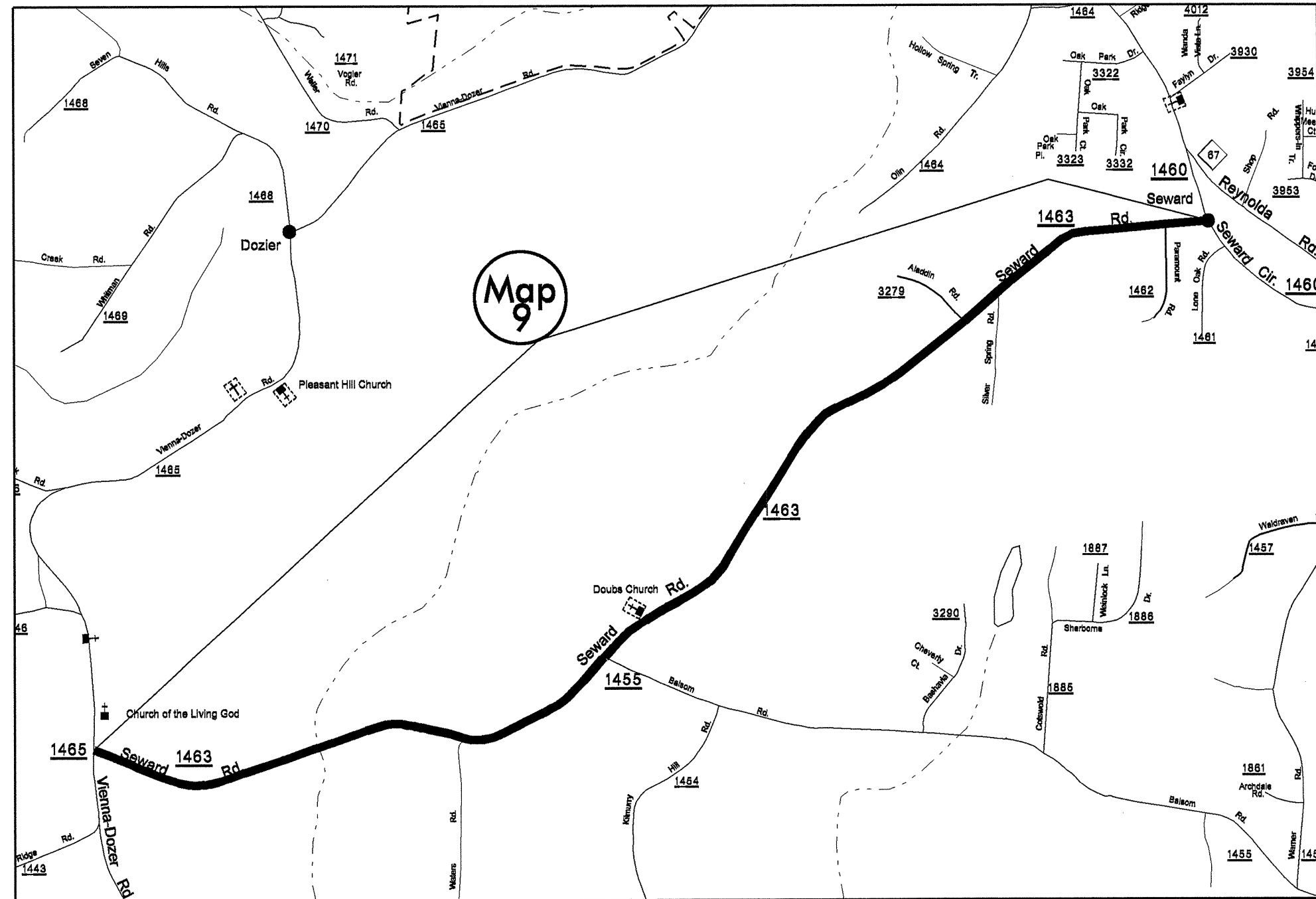

**MAP NO. 9**  
**SEWARD ROAD (SR 1463)**  
 All Patching done by state forces.

**FORSYTH COUNTY**  
 NORTH CAROLINA

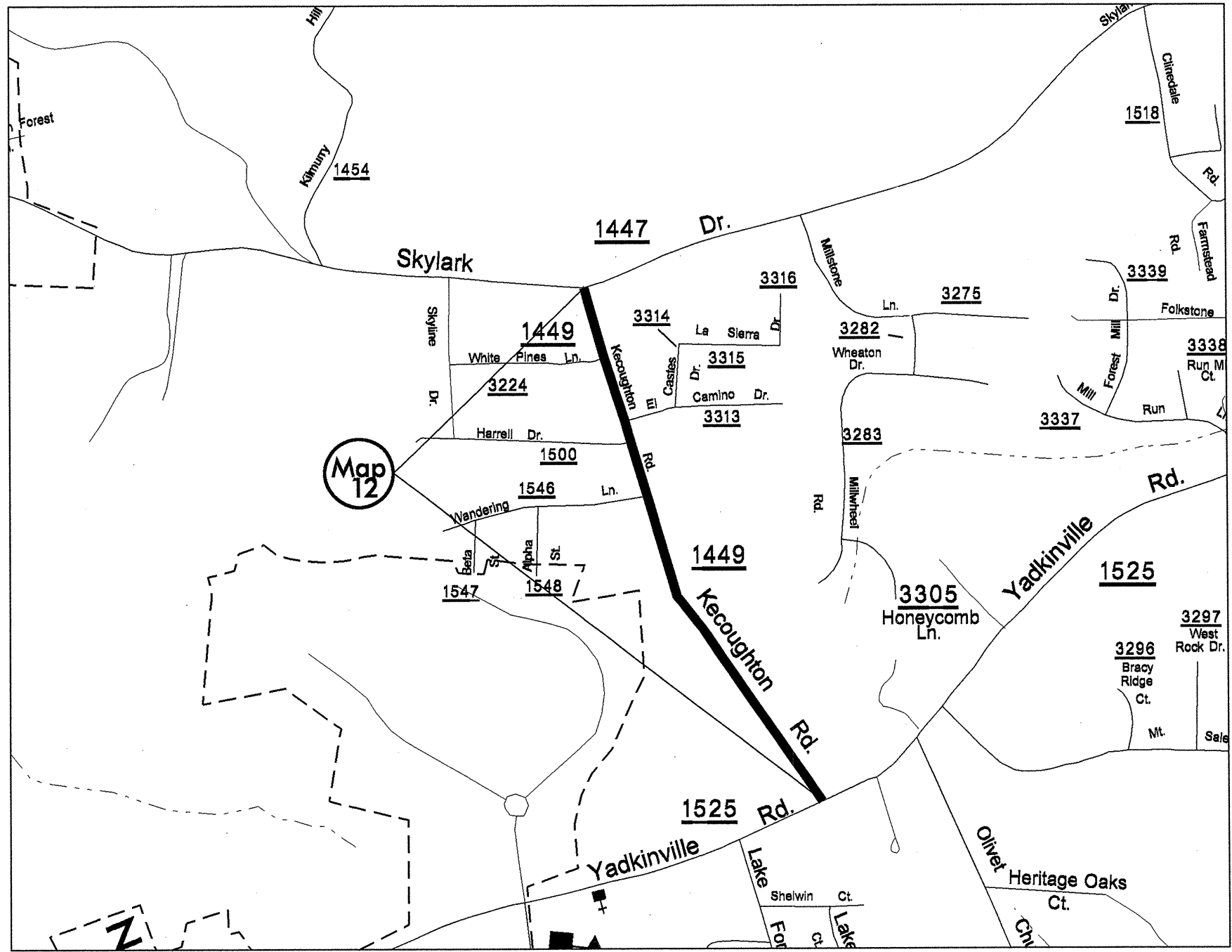

MAP NO. 12  
 KECOUGHTAN ROAD  
 All Patching done by state forces.

**FORSYTH COUNTY**  
 NORTH CAROLINA



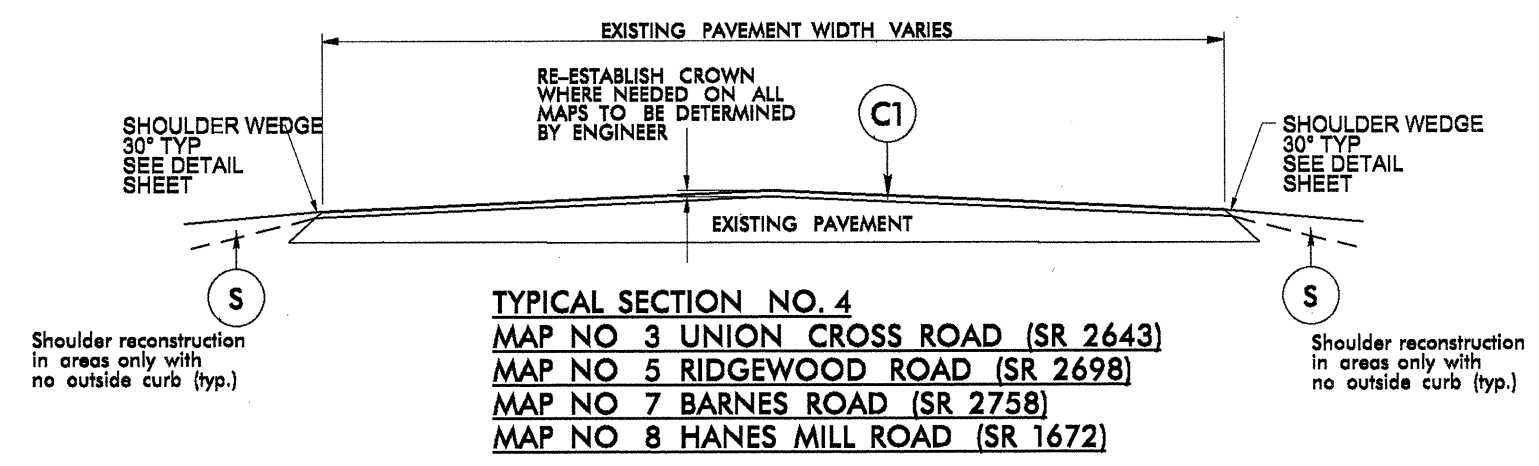
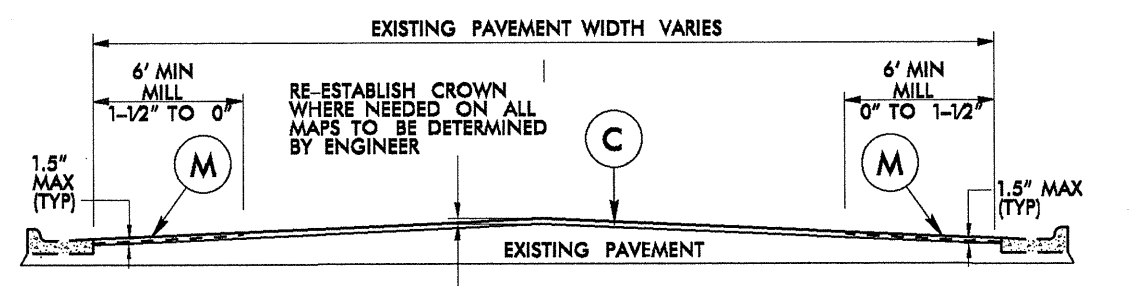
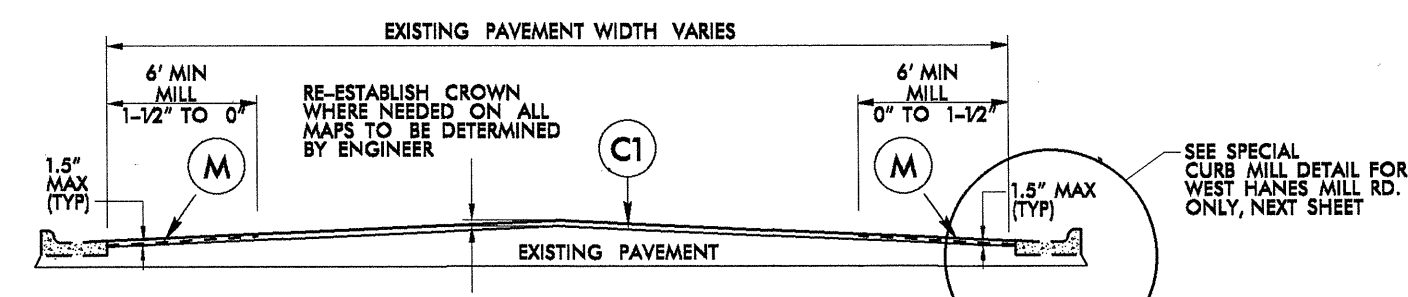
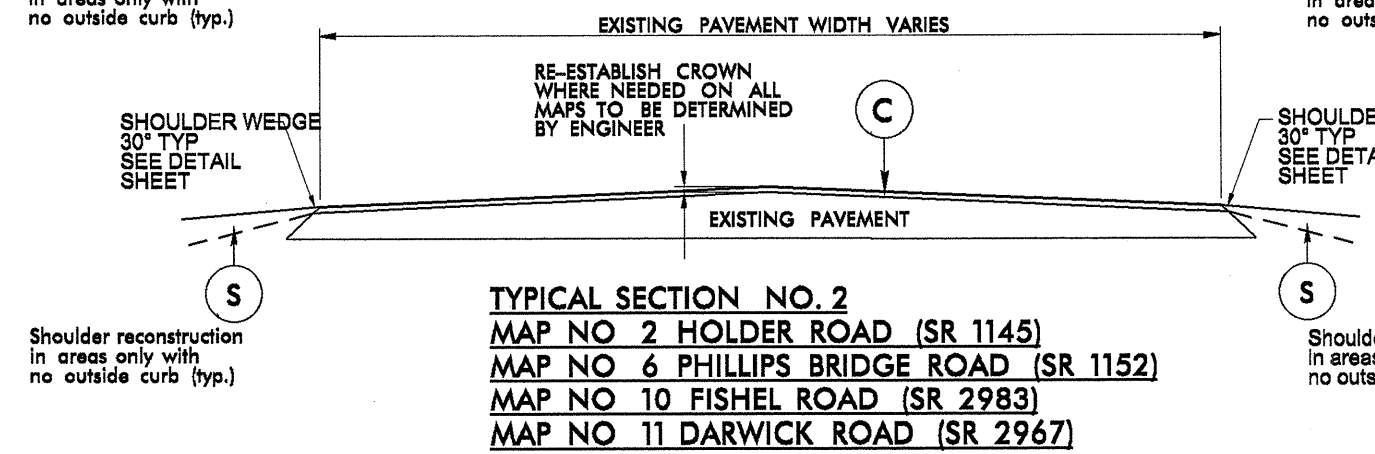
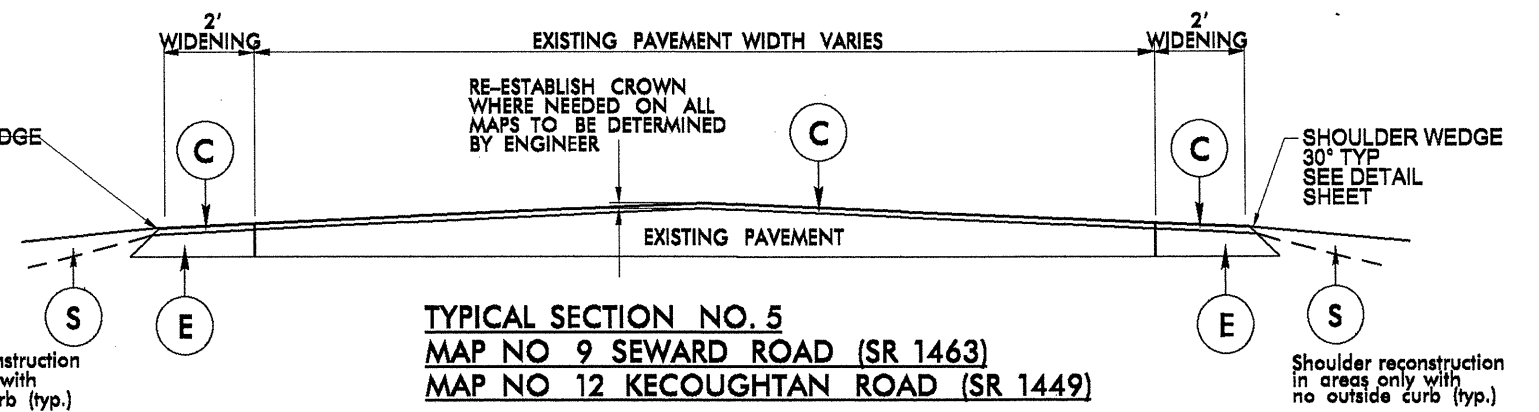
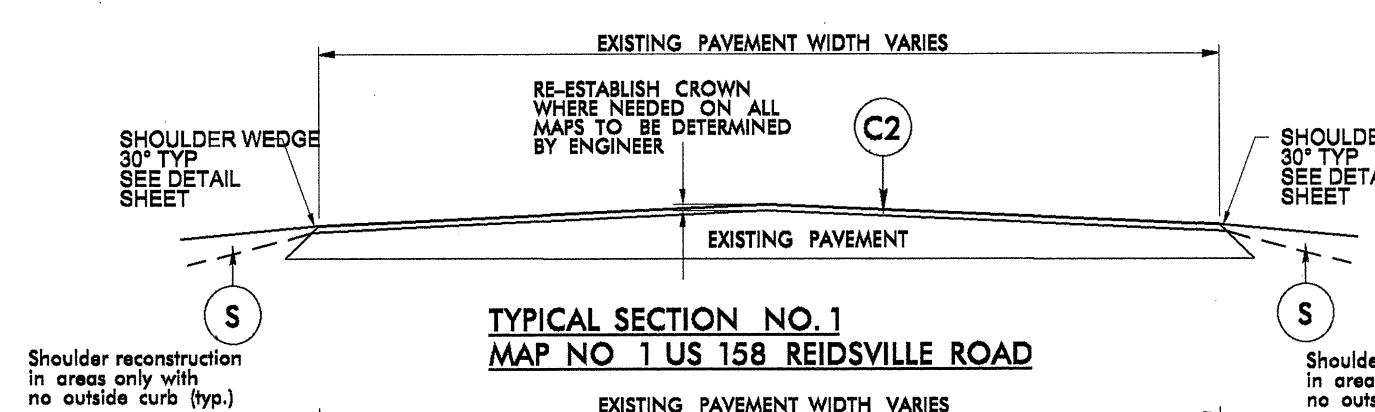

PAVEMENT SCHEDULE	
C	PROP. APPROX. 1 1/2" ASPHALT CONCRETE SURFACE COURSE, TYPE SF9.5A, TO BE APPLIED AT AN AVERAGE RATE OF 165 LBS PER SQ YD
C1	PROP. APPROX. 1 1/2" ASPHALT CONCRETE SURFACE COURSE, TYPE S9.5B, TO BE APPLIED AT AN AVERAGE RATE OF 168 LBS PER SQ YD
C2	PROP. APPROX. 1 1/2" ASPHALT CONCRETE SURFACE COURSE, TYPE S9.5C, TO BE APPLIED AT AN AVERAGE RATE OF 168 LBS PER SQ YD
E	PROP. APPROX. 5 1/2" ASPHALT CONCRETE BASE COURSE, TYPE B25.0B, TO BE APPLIED AT AN AVERAGE RATE OF 627 LBS PER SQ YD
M	MILL ASPHALT PAVEMENT, 0" TO 1 1/2" DEPTH
M1	MILL ASPHALT PAVEMENT, 1 1/2" DEPTH
M2	MILL ASPHALT PAVEMENT, 1 1/2" TO 3" DEPTH
M3	MILL ASPHALT PAVEMENT, 0" TO 3" DEPTH
M4	MILL ASPHALT PAVEMENT, 3" DEPTH
S	SHOULDER RECONSTRUCTION (SEE DETAIL)
U	EXISTING PAVEMENT

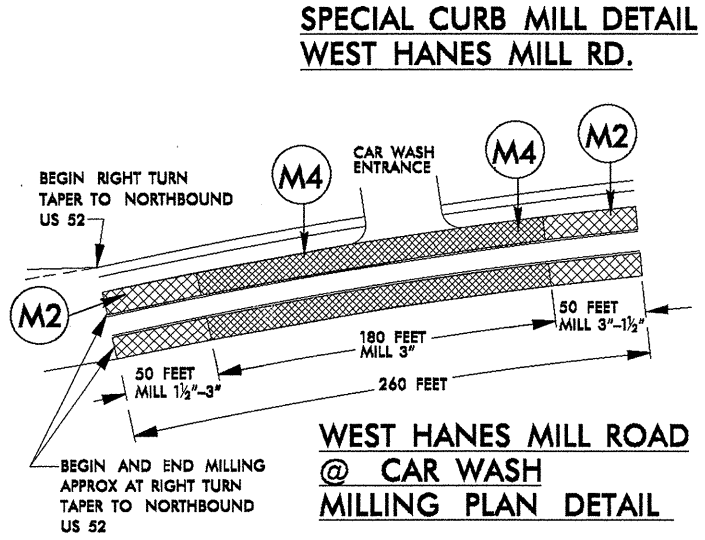
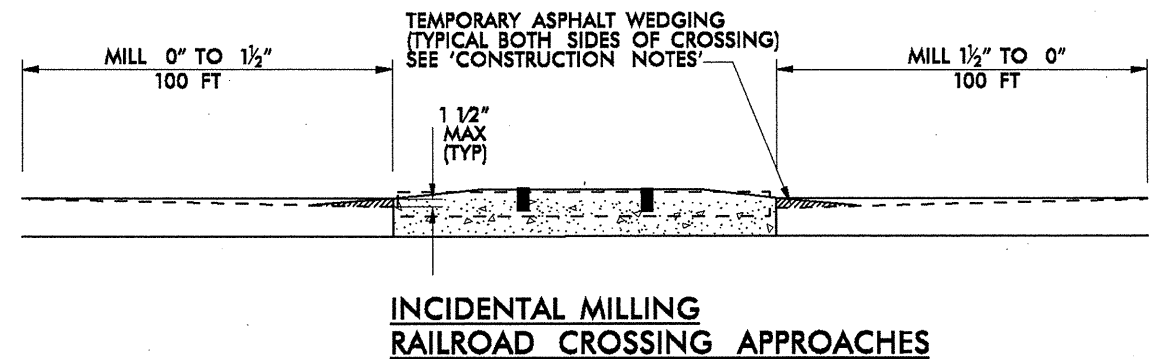
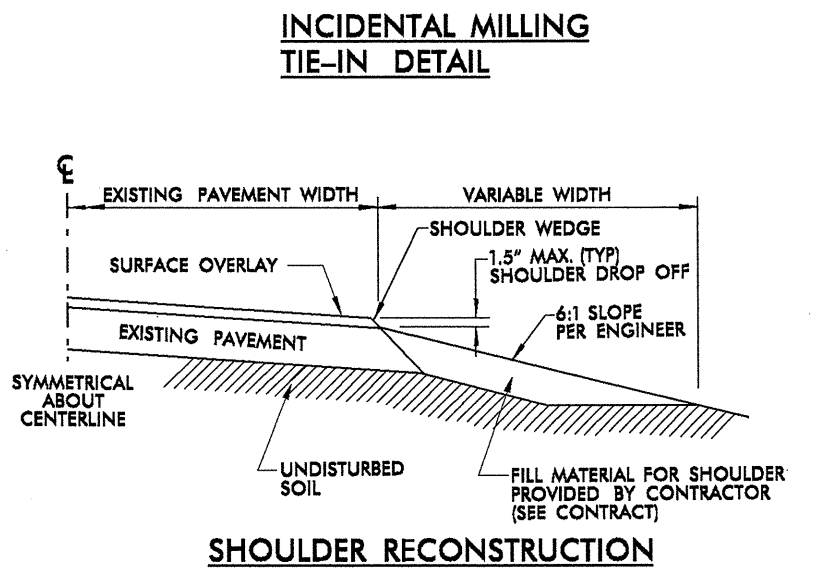
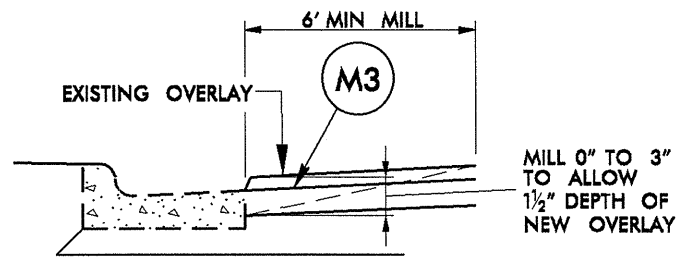
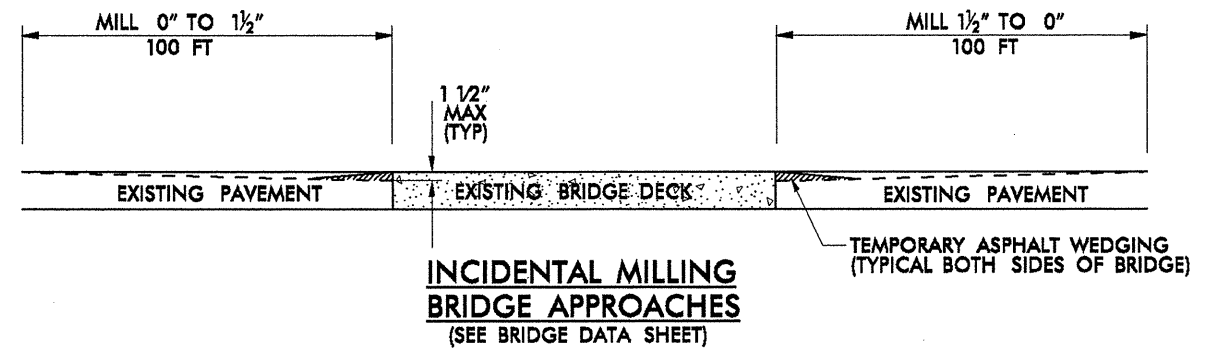
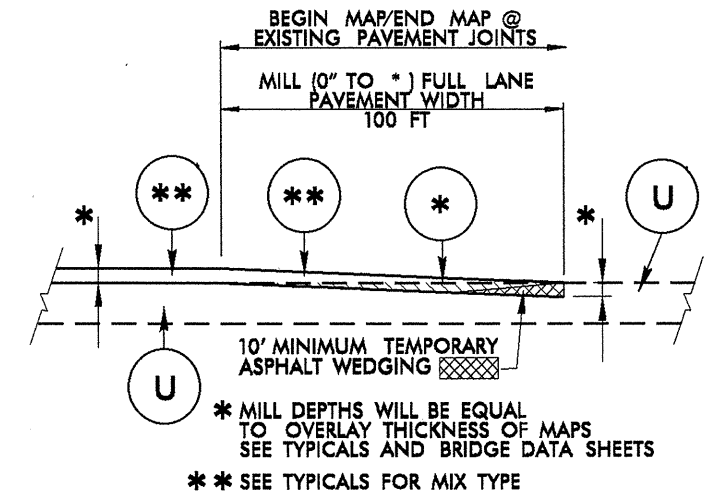
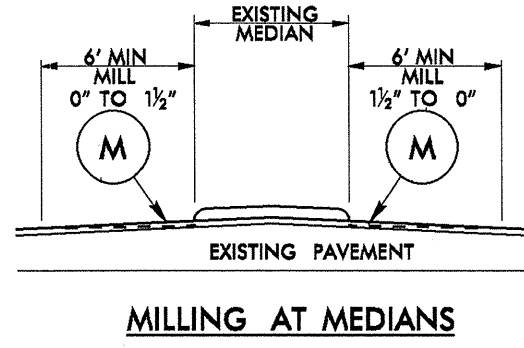
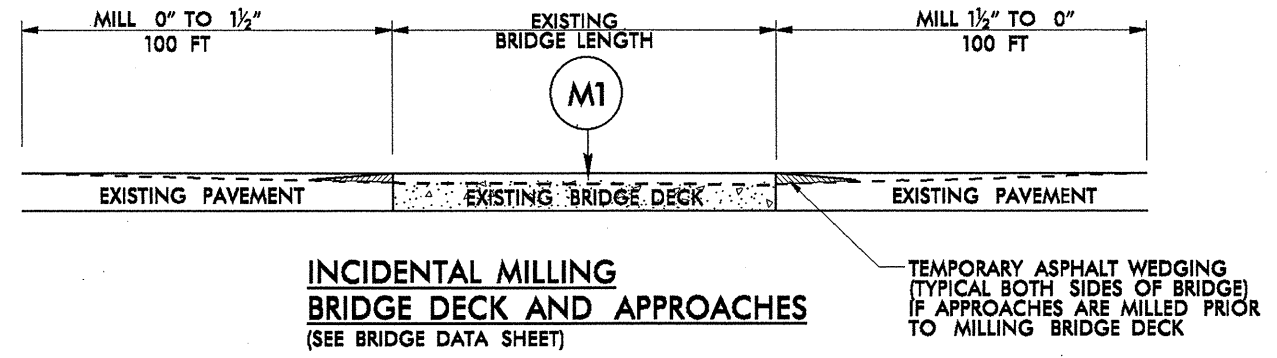

PAVEMENT SCHEDULE	
C	PROP. APPROX. 1 1/2" ASPHALT CONCRETE SURFACE COURSE, TYPE SF9.5A, TO BE APPLIED AT AN AVERAGE RATE OF 165 LBS PER SQ YD
C1	PROP. APPROX. 1 1/2" ASPHALT CONCRETE SURFACE COURSE, TYPE S9.5B, TO BE APPLIED AT AN AVERAGE RATE OF 168 LBS PER SQ YD
C2	PROP. APPROX. 1 1/2" ASPHALT CONCRETE SURFACE COURSE, TYPE S9.5C, TO BE APPLIED AT AN AVERAGE RATE OF 168 LBS PER SQ YD
E	PROP. APPROX. 5 1/2" ASPHALT CONCRETE BASE COURSE, TYPE B25.0B, TO BE APPLIED AT AN AVERAGE RATE OF 627 LBS PER SQ YD
M	MILL ASPHALT PAVEMENT, 0" TO 1/2" DEPTH
M1	MILL ASPHALT PAVEMENT, 1/2" DEPTH
M2	MILL ASPHALT PAVEMENT, 1/2" TO 3" DEPTH
M3	MILL ASPHALT PAVEMENT, 0" TO 3" DEPTH
M4	MILL ASPHALT PAVEMENT, 3" DEPTH
S	SHOULDER RECONSTRUCTION (SEE DETAIL)
U	EXISTING PAVEMENT

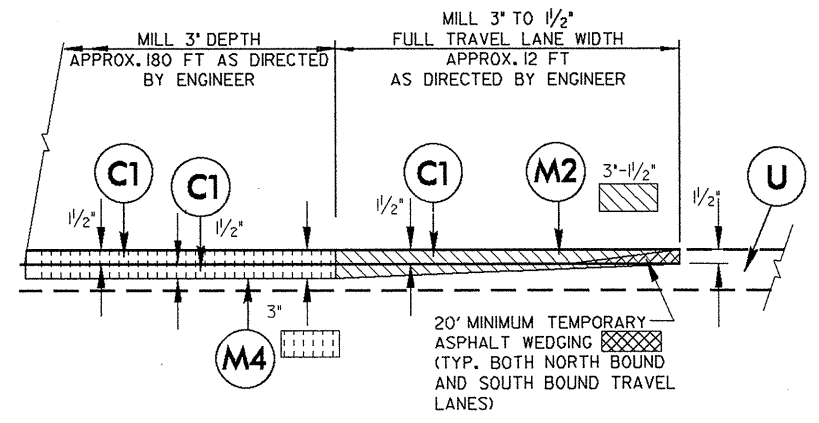
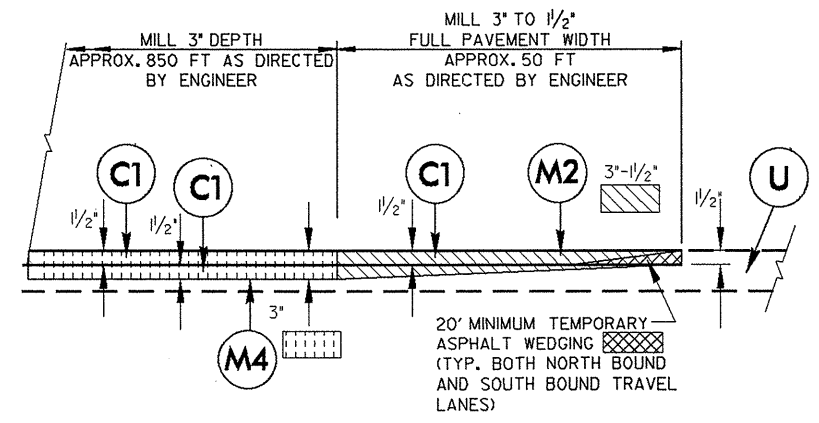

**INDUSTRIAL PARK DRIVE  
MILLING DETAIL**

**WEST HANES MILL ROAD  
@ CAR WASH  
MILLING DETAIL**

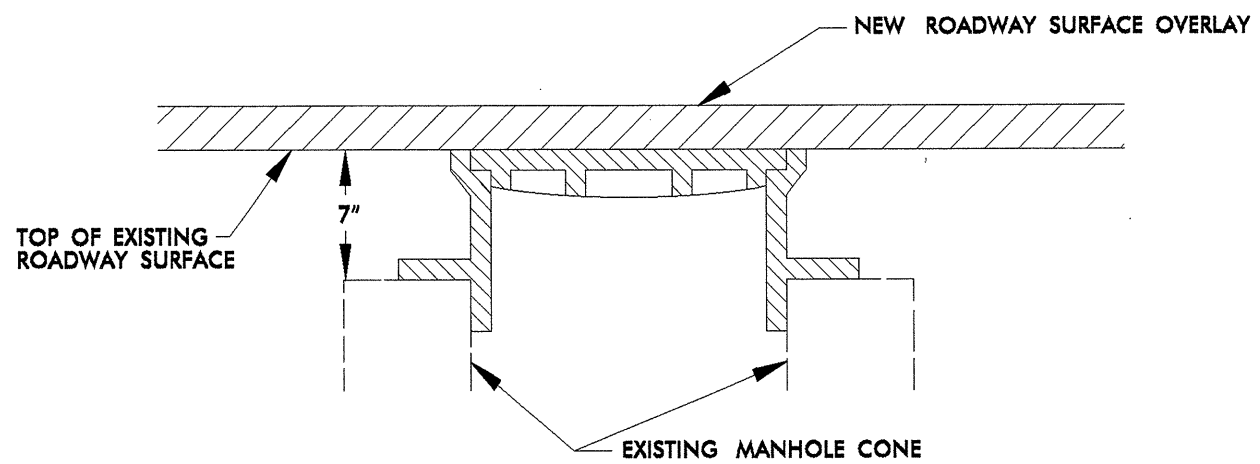

**STEP 1**

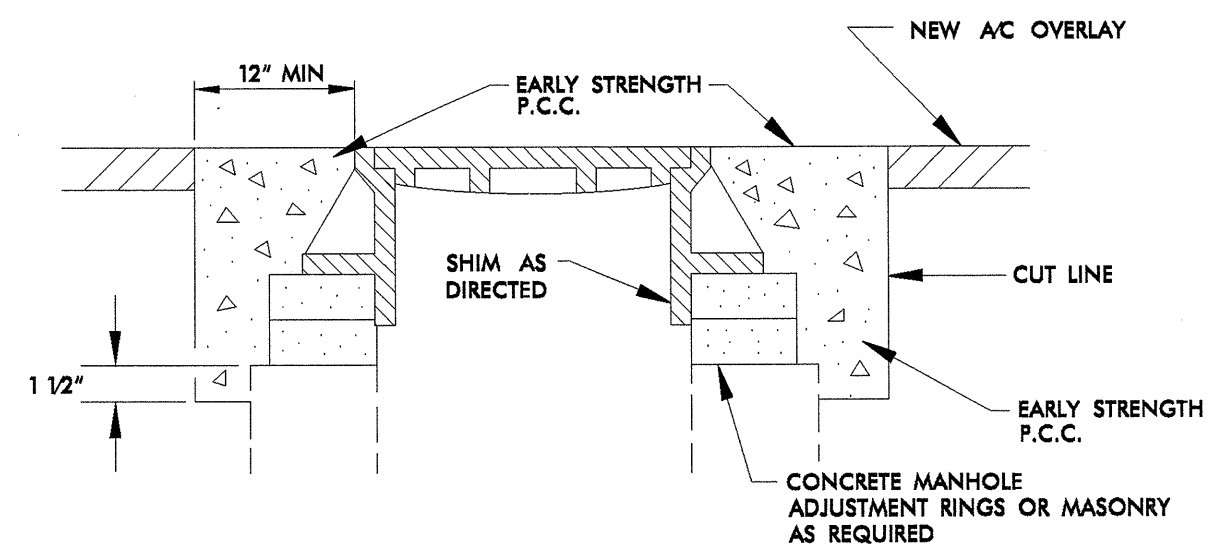

**STEPS 2,3, & 4**

- STEP 1 COVER EXISTING MANHOLE WITH APPROVED MATERIAL AND CONSTRUCT OVERLAY ACROSS TOP OF MANHOLE
- STEP 2 SAW CUT EXCAVATION AROUND MANHOLE 12" MIN. FROM MANHOLE FRAME.
- STEP 3 RAISE MANHOLE FRAME RINGS TO FINISH PAVEMENT PROFILE AND CROSS SLOPE.
- STEP 4 BACKFILL WITH EARLY STRENGTH P.C.C. TO DEPTHS AS DIRECTED.

**MANHOLE ADJUSTMENT DETAIL**

**CONSTRUCTION NOTES:**

1. ALL QUANTITIES ARE "ESTIMATED" AS INDICATED IN THE "SUMMARY OF QUANTITIES".
2. CONSTRUCTION SHALL PROGRESS IN PHASES, IN THE ORDER INDICATED BELOW:
  - PHASE 1 - MILLING AND PATCHING (WHEN REQUIRED)
  - PHASE 2 - SURFACE OVERLAY
  - PHASE 3 - SHOULDER DROP-OFF REPAIR (AS NEEDED AND DIRECTED BY ENGINEER)
  - PHASE 4 - UTILITY ADJUSTMENTS (MANHOLE RING/COVER, VALVE/METER BOX RING/COVER, CATCH BASIN GRATE/COVER, DROP INLET GRATE/COVER, ETC.) WHEN REQUIRED.
3. BRIDGES THAT HAVE FLOOR DRAINS, SHALL HAVE ALL FLOOR DRAINS LEFT OPEN. EXTRA CARE SHALL BE EXERCISED IN MILLING (IF REQUIRED) AND IN PLACING THE WEARING SURFACE AROUND FLOOR DRAINS SO AS NOT TO HINDER EFFECTIVE DRAINAGE.
4. TEMPORARY ASPHALT WEDGING SHALL BE PLACED ON THE SAME DAY THAT BRIDGE AND/OR RAILROAD APPROACHES ARE MILLED (AND IF APPROACHES ARE MILLED PRIOR TO BRIDGE DECK).
5. FOR TWO-LANE ROADWAYS - IT SHALL BE UNDERSTOOD THAT TYPICALLY ON A ROADWAY MEASURING 20 FEET OR LESS IN WIDTH, THE CENTER OF THE WHITE EDGELINE SHALL BE LOCATED SIX INCHES FROM THE EDGE OF PAVEMENT ON EITHER SIDE OF THE ROADWAY; ON A ROADWAY MEASURING 22 FEET IN WIDTH, TRAVEL LANES SHALL MEASURE 10 FEET AND THE WHITE EDGELINE SHALL BE LOCATED ONE FOOT FROM THE EDGE OF PAVEMENT ON EITHER SIDE; ON A ROADWAY MEASURING 24 FEET IN WIDTH, TRAVEL LANES SHALL MEASURE 11 FEET AND THE WHITE EDGELINE SHALL BE LOCATED ONE FOOT FROM THE EDGE OF PAVEMENT ON EITHER SIDE; ON A ROADWAY MEASURING 26 FEET OR MORE IN WIDTH, TRAVEL LANES SHALL MEASURE 12 FEET AND THE WHITE EDGELINE SHALL BE LOCATED NO LESS THAN ONE FOOT FROM THE EDGE OF PAVEMENT ON EITHER SIDE. THIS SHALL BE STANDARD PRACTICE UNLESS OTHERWISE DIRECTED BY THE ENGINEER.
6. PAPER JOINTS ARE TO BE PLACED BETWEEN DAYS OF PAVING OPERATIONS AS SPECIFIED IN THE STANDARD SPECIFICATIONS SECTION 610-11.
7. ALL MILLED AREAS WILL BE PAVED WITHIN 72 HOURS UNLESS APPROVED BY THE ENGINEER.
9. REPLACE ANY PORTION OF STOP BARS AND OTHER PAVEMENT MARKINGS AT ANY INTERSECTION INCLUDING Y-LINES NOT ACTUALLY BEING PAVED OVER, THAT ARE OBLITERATED BY THE PAVING OPERATION EITHER BY HAULING WHEEL TRACKS OR TACK TRUCK BY THE END OF EACH RESURFACING OPERATION

PROJECT REFERENCE NO.	SHEET NO.
9CR.10341.130, ETC	12

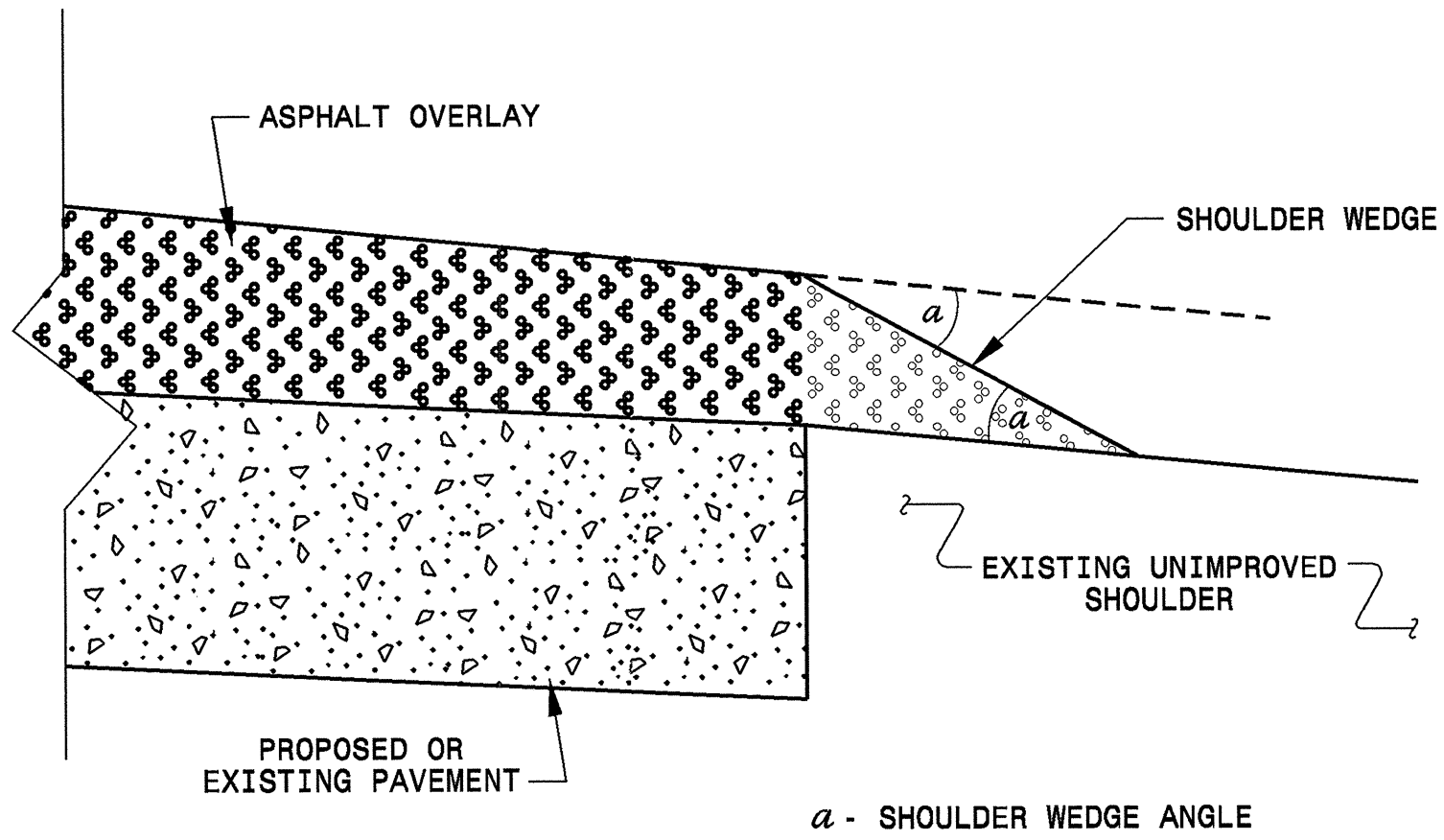

## SHOULDER WEDGE DETAIL

04-MAY-2012 10:37  
 C:\Users\p\p\p\ter\Documents\misc\shoulderwedge\std\std16aug2011.dgn  
 P:\p\p\ter\AT\CSD\26188

<b>CONTRACT STANDARDS AND DEVELOPMENT UNIT</b>	
Office 919-707-6950	FAX 919-250-4119
<b>SHOULDER WEDGE DETAIL</b>	
ORIGINAL BY: T.SPELL	DATE: 7-19-11
MODIFIED BY:	DATE:
CHECKED BY:	DATE:
FILE SPEC.: s:\user\details\stand\shoulderwedge\std16.dgn	

NOTES: Less than 5' - 10' undisturbed buffer from ROW, ditchline, water feature, or drainage inlet, add BMP.

BMP Options: Wattle or Silt Fence

# EROSION CONTROL DETAIL

PROJECT REFERENCE NO.	SHEET NO.
9CR.10341.130, 9CR.20341.130	13

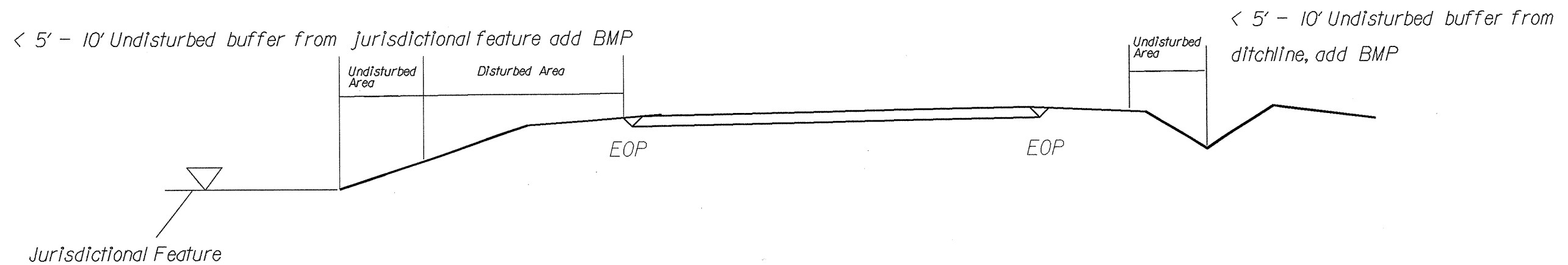
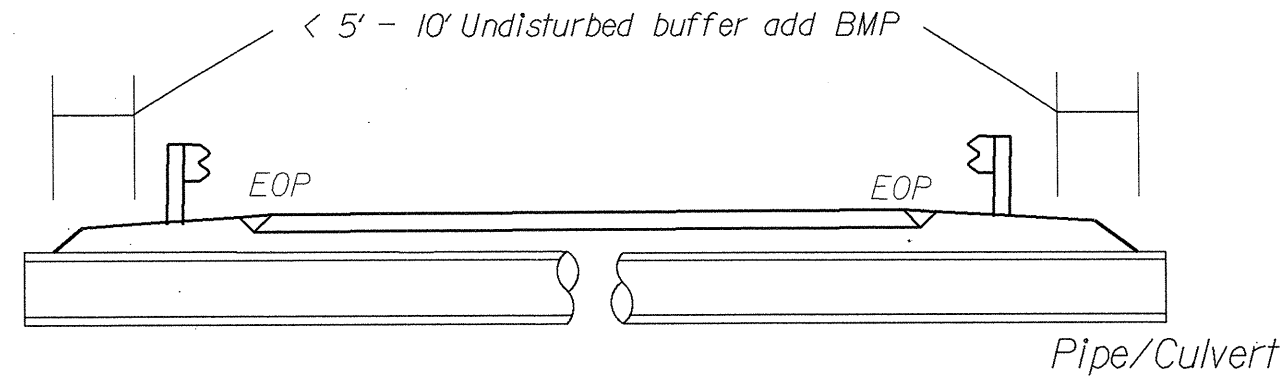

Use BMP's if shoulders and/or frontslopes and/or ditchline and/or backslopes are disturbed

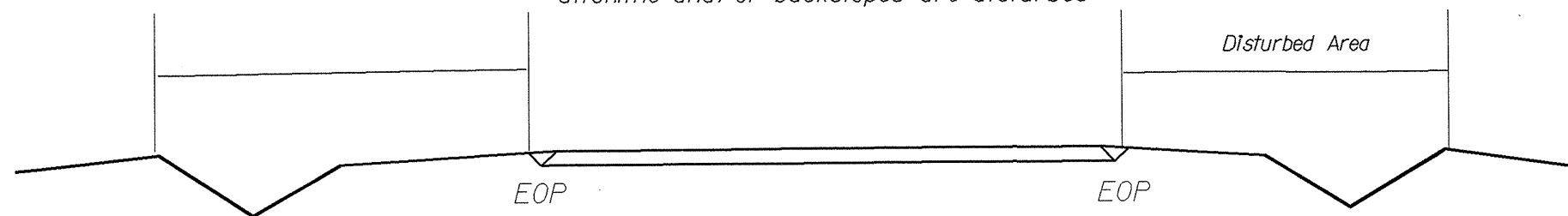

< 5' - 10' Undisturbed buffer from inlet, add wattle

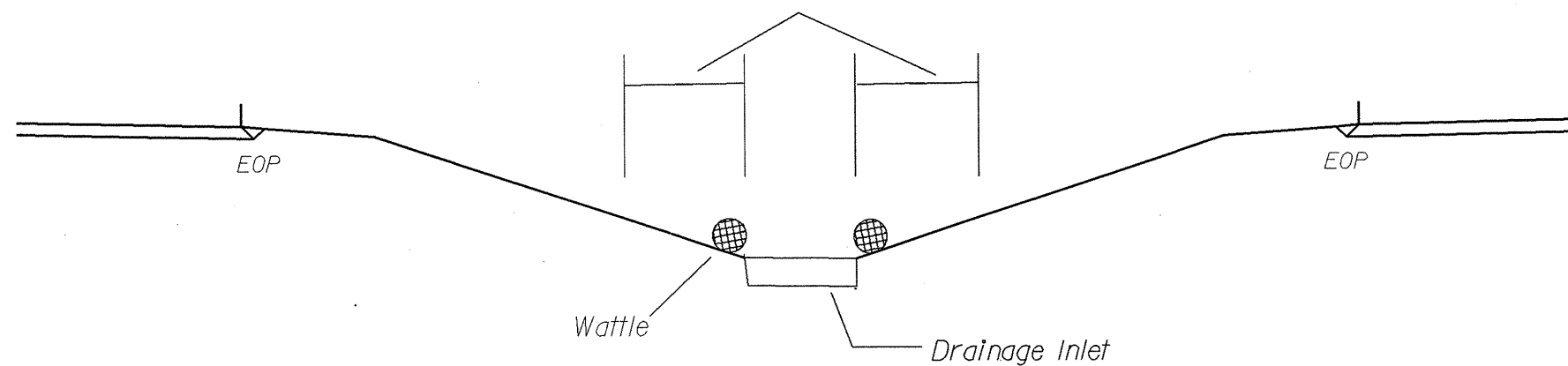

NOT TO SCALE

# WATTLE DETAIL

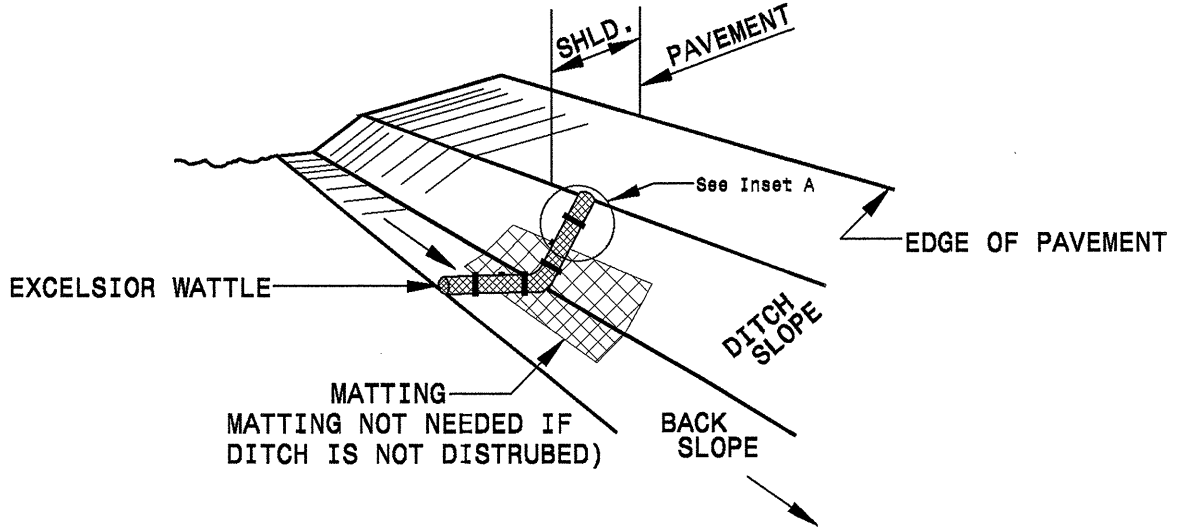

**ISOMETRIC VIEW**

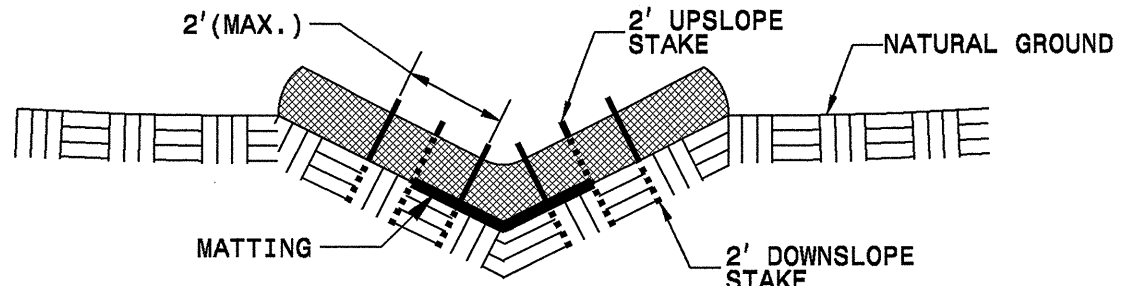

**CROSS SECTION VEE DITCH**

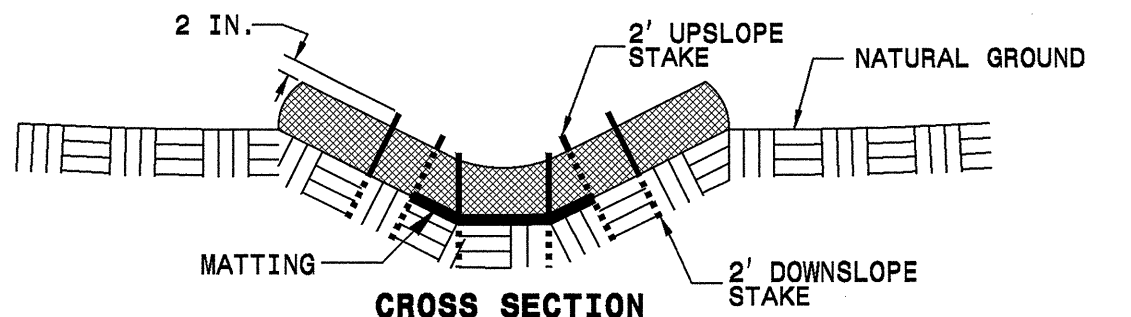

**CROSS SECTION TRAPEZOIDAL DITCH**

- NOTES:
- USE MINIMUM 12 IN. DIAMETER EXCELSIOR WATTLE.
  - USE 2 FT. WOODEN STAKES WITH A 2 IN. BY 2 IN. NOMINAL CROSS SECTION.
  - ONLY INSTALL WATTLE(S) TO A HEIGHT IN DITCH SO FLOW WILL NOT WASH AROUND WATTLE AND SCOUR DITCH SLOPES AND AS DIRECTED.
  - INSTALL A MINIMUM OF 2 UPSLOPE STAKES AND 4 DOWNSLOPE STAKES AT AN ANGLE TO WEDGE WATTLE TO BOTTOM OF DITCH.
  - PROVIDE STAPLES MADE OF 0.125 IN. DIAMETER STEEL WIRE FORMED INTO A U SHAPE NOT LESS THAN 12" IN LENGTH.
  - INSTALL STAPLES APPROXIMATELY EVERY 1 LINEAR FOOT ON BOTH SIDES OF WATTLE AND AT EACH END TO SECURE IT TO THE SOIL.
  - IF DITCH WILL BE DISTURBED, INSTALL MATTING IN ACCORDANCE WITH SECTION 1631 OF THE STANDARD SPECIFICATIONS.

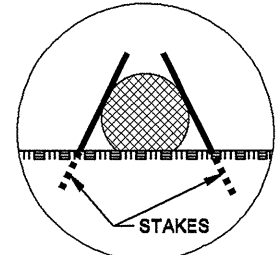

**INSET A**

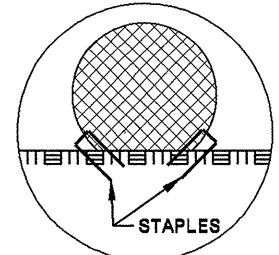

**INSET B**

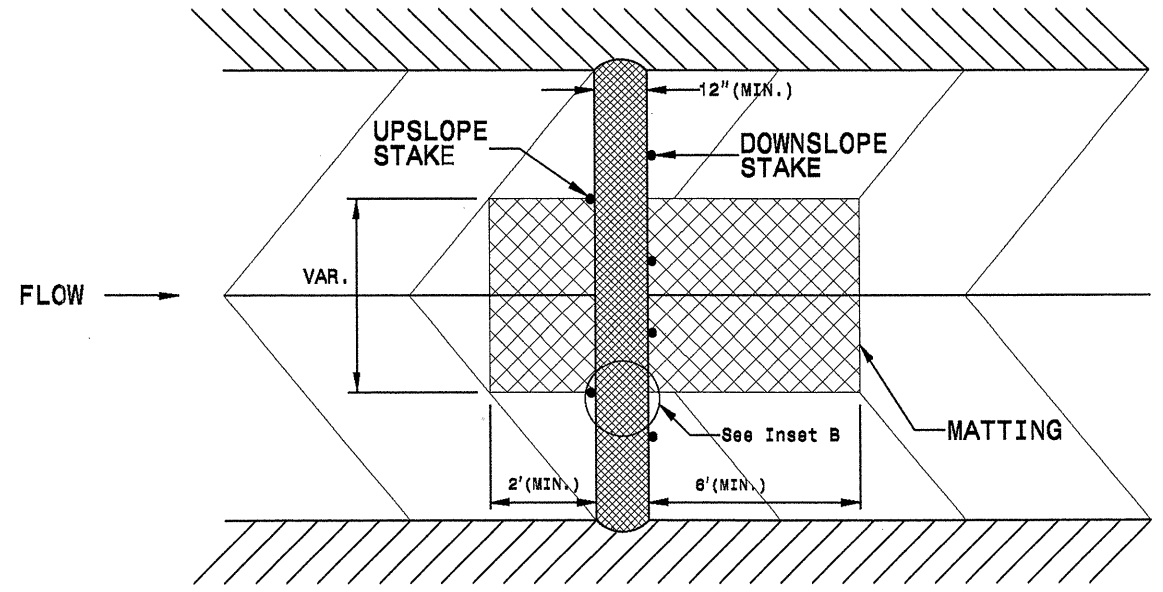

**TOP VIEW**

## 2012\_Resurfacing\_FORSYTH SUMMER 2012

									PROJECT NO.		SHEET NO.	
									9CR.10341.130		15	
									9CR.20341.130			
Map No.	Route No.	Route Name	Bridge No.	Feature Intersected	Floor Construction	Clear Roadway Width (Ft)	Horizontal Clearance Under (Ft.)	Vertical Clearance Under	2nd Opening Clearance Under	Length (Ft)	Posting	Recommended Treatment, From Bridge Maintenance
1	US 158	US 158 REIDSVILLE ROAD	164	EAST BELEWS CREEK	PPCCS, 3.25 AWS	44.8	NA	NA	NA	97	NA	MILL APPROACHES, MILL DECK AND REPAVE
3	SR 2643	UNION CROSS ROAD	76	SOUTH FORK CREEK	PPCCS, 3.0 AWS	30.3	NA	NA	NA	92	NA	MILL APPROACHES, MILL DECK AND REPAVE
5	SR 2698	RIDGEWOOD ROAD	394	US 311	8 RC SLAB	60	72.5	16 FT 05 IN SBL	18 FT 08 IN NBL	321	NA	MILL APPROACHES, <u>DO NOT PAVE ON BRIDGE</u>
6	SR 1152	PHILLIPS BRIDGE ROAD	98	MUDDY CREEK	8 RC SLAB	31	NA	NA	NA	331	NA	MILL APPROACHES, <u>DO NOT PAVE ON BRIDGE</u>
7	2758	BARNES ROAD	132	WINSTON-SALEM S.B. RXR	8 1/4 RC SLAB	34	NA	NA	NA	102	NA	MILL APPROACHES, <u>DO NOT PAVE ON BRIDGE</u>
8	SR 1672	HANES MILL ROAD	290	US 52	7 3/4 RC SLAB	28	61	15 FT 06 IN	15 FT 08 IN US 52 NBL	229	NA	MILL APPROACHES, <u>DO NOT PAVE ON BRIDGE</u>
10	2983	FISHEL ROAD	23	US 52	8 1/4 RC SLAB	36	65	17 FT 00 IN US 52 SBL	17 FT 03 IN US 52 NBL	225	NA	MILL APPROACHES, <u>DO NOT PAVE ON BRIDGE</u>
10	2983	FISHEL ROAD	182	PRONG SOUTH FORK CREEK	PPCCS, 3.25 AWS	34.3	NA	NA	NA	70	NA	MILL APPROACHES, MILL DECK AND REPAVE

PROJECT NO.	SHEET NO.	TOTAL NO.
9CR.10341.130, 9CR.20341.130	16	

### SUMMARY OF QUANTITIES

PROJECT NO	COUNTY	MAP NO	ROUTE	DESCRIPTION	TYP	FINAL SURFACE TESTING REQUIRED	AGGREGATE SHOULDER BORROW ALLOWED	LENGTH MI	WIDTH FT	INCIDENTAL STONE BASE TONS	BORROW CY	SHOULDER RECONSTRUCTION SMI	INCIDENTAL MILLING SY	MILLING ASPHALT PAVEMENT, 1 1/2" DEPTH SY	MILLING ASPHALT PAVEMENT, 3" DEPTH SY	MILLING ASPHALT PAVEMENT, 0" TO 1 1/2" DEPTH SY	MILLING ASPHALT PAVEMENT, 1 1/2" TO 3" DEPTH SY	MILLING ASPHALT PAVEMENT, 0" TO 3" DEPTH SY	BASE COURSE, B25.0B TONS	SURFACE COURSE, S9.5B TONS	SURFACE COURSE, S9.5C TONS	SURFACE COURSE, SF9.5A TONS	ASPHALT BINDER FOR PLANT MIX TONS	ADJ. OF MANHOLES EA	ADJ. OF METER OR VALVE BOX EA	TEMPORARY SILT FENCE LF	WATTLE LF		
9CR.10341.130	Forsyth	1	US 158 - REIDSVILLE ROAD	FROM PAVEMENT JT ON WEST SIDE OF NC 66 TO GUILFORD COUNTY LINE	1	NO	YES	7.09	28	312	851	14.18	1,244	483							11,481		677		2	2,836	284		
<b>TOTAL FOR PROJ NO. 9CR.10341.130</b>								<b>7.09</b>		<b>312</b>	<b>851</b>	<b>14.18</b>	<b>1,244</b>	<b>483</b>								<b>11,481</b>		<b>677</b>		<b>2</b>	<b>2,836</b>	<b>284</b>	
9CR.20341.130	Forsyth	2	SR 1145 HOLDER ROAD	FROM LEWISVILLE-CLEMMONS RD (SR 1103) TO DEAD END	2,3	NO	YES	1.269	20	102	152	2.54	445				574						1,463	98	1	5	508	51	
		3	SR 2643 UNION CROSS ROAD	FROM PAVEMENT JOINT AT WOODGATE DRIVE TO PAVEMENT JOINT AT NC 109	4	NO	YES	3.24	24	123	389	6.48	1,201	307							4,237			254		3	1,296	130	
		4	SR 4319 INDUSTRIAL PARK DR.	FROM PAVEMENT JOINT AT NC 66 TO PAVEMENT JOINT AT MACY GROVE ROAD (SR 2601)	6	NO		0.83	36				800		3,400	4,310	400				1,981			119					
		5	SR 2698 RIDGEWOOD ROAD	FROM UNION CROSS RD (SR 2643) TO OLD HIGHPOINT RD (SR 1003)	4,6	NO	YES	1.607	24	54	129	2.51	2,112								3,012			181	3		643	64	
		6	SR 1152 PHILLIPS BRIDGE ROAD	FROM COUNTRY CLUB RD. (SR 1001) TO STYERS FERRY RD. (SR 1103)	2	NO	YES	1.409	20	33	169	2.82	1,134										1,510	101		1	564	56	
		7	SR 2758 BARNES ROAD	FROM PAV'T JT AT SOUTH MAIN ST. (SR 4205) TO PAV'T JT. AT OLD LEXINGTON RD. (SR 2743)	4	NO	YES	1.43	24	54	172	2.86	1,290								2,137			128	1	16	572		
		8	SR 1672 WEST HANES MILL ROAD	FROM RR CROSSING TO UNIVERSITY PKWY (SR 4000)	4,6	NO		1.33	36				2,147		480	8,013	267	640			3,272			196	7	14			
		9	SR 1463 SEWARD ROAD	FROM SEWARD CIRCLE (SR 1460) TO VIENNA-DOZER ROAD (SR 1465)	5	NO	YES	2.736	22	147	328	5.47	400							2,468			3,223	325			1,094	109	
		10	SR 2983 FISHEL ROAD	FROM STOP BAR @ NC 150 (PETERS CREEK PKWY.) TO SOUTH MAIN STREET (SR 4205)	2	NO	YES	2.14	20	108	257	4.28	2,001	2,401									2,293	154		3	856	86	
		11	SR 2967 DARWICK ROAD	FROM OLD SALISBURY ROAD (SR 3011) TO EBERT ROAD (SR 2902)	2	NO	YES	2.123	21	111	255	4.25	467										2,510	168	4	5	849	85	
		12	SR 1449 KECOUGHTAN ROAD	YADKINVILLE ROAD (SR 1525) TO SKYLARK (SR 1447)	5	NO	YES	0.762	22	72	91	1.52							687				898	90		1	305	30	
<b>TOTAL FOR PROJ NO. 9CR.20341.130</b>								<b>18.876</b>		<b>804</b>	<b>1,942</b>	<b>32.73</b>	<b>11,997</b>	<b>2,708</b>	<b>3,880</b>	<b>14,767</b>	<b>667</b>	<b>640</b>			<b>3,155</b>	<b>14,639</b>		<b>11,897</b>	<b>1,814</b>	<b>16</b>	<b>48</b>	<b>6,687</b>	<b>611</b>
<b>GRAND TOTAL</b>								<b>25.966</b>		<b>1,116</b>	<b>2,793</b>	<b>46.91</b>	<b>13,241</b>	<b>3,191</b>	<b>3,880</b>	<b>14,767</b>	<b>667</b>	<b>640</b>			<b>3,155</b>	<b>14,639</b>	<b>11,481</b>	<b>11,897</b>	<b>2,491</b>	<b>16</b>	<b>50</b>	<b>9,523</b>	<b>895</b>

NOTE: All Quantities listed include turn lanes and are estimates; Payment will be based on actual field measurements and quantities received.



PROJECT NO.	SHEET NO.	TOTAL NO.
9CR.10341.130, 9CR.20341.130	17	

## THERMOPLASTIC AND PAINT QUANTITIES

PROJECT NO	COUNTY	MAP NO	ROUTE	DESCRIPTION	LENGTH	WIDTH	4685000000-E		4686000000-E		4695000000-E		4697000000	4705000000	4710000000-E	4721000000-E			4725000000-E			4810000000-E		4845000000-N		4905000000-N			
							4" X 90 M WHITE THERMO LF	4" X 90 M YELLOW THERMO LF	4" X 120 M YELLOW THERMO LF	4" X 120 M WHITE THERMO LF	8" X 90 M YELLOW THERMO LF	8" X 90 M WHITE THERMO LF	8" X 120 M WHITE THERMO LF	16" X 120 M WHITE THERMO LF	24" X 120 M WHITE THERMO LF	THERMO MSG SCHOOL 120 M EA	THERMO RXR 120 M EA	THERMO MSG ONLY 120 M EA	THERMO LT ARROW 90 M EA	THERMO RT ARROW 90 M EA	THERMO LT & RT ARROW 90 M EA	THERMO STR & RT ARROW 90 M EA	THERMO STR ARROW 90 M EA	4" YELLOW PAINT LF	4" WHITE PAINT LF	PAINT STR ARROW EA	PAINT LT ARROW EA	SNOW PLOWABLE MARKERS EA	
9CR.10341.130	Forsyth	1	US 158 - REIDSVILLE ROAD	FROM PAVEMENT JT ON WEST SIDE OF NC 66 TO GUILFORD COUNTY LINE	7.09	28	74,870	1,725	83,932	1,094	1,377				319				20	1							468		
<b>TOTAL FOR PROJ NO. 9CR.10341.130</b>							<b>7.09</b>		<b>74,870</b>	<b>1,725</b>	<b>83,932</b>	<b>1,094</b>	<b>1,377</b>		<b>319</b>				<b>20</b>	<b>1</b>							<b>468</b>		
									<b>76,595</b>	<b>85,026</b>	<b>1,377</b>								<b>21</b>										
9CR.20341.130	Forsyth	2	SR 1145 HOLDER ROAD	FROM LEWISVILLE-CLEMMONS RD (SR 1103) TO DEAD END	1.269	20	13,654		14,357	113	67				142	12			1		2								
9CR.20341.130	Forsyth	3	SR 2643 UNION CROSS ROAD	FROM PAVEMENT JOINT AT WOODGATE DRIVE TO PAVEMENT JOINT AT NC 109	3.24	24	34,862		34,214																				
9CR.20341.130	Forsyth	4	SR 4319 INDUSTRIAL PARK DR.	FROM PAVEMENT JOINT AT NC 66 TO PAVEMENT JOINT AT MACY GROVE ROAD (SR 2601)	0.83	36			10,958	180					87				28	2		2			2,375				
9CR.20341.130	Forsyth	5	SR 2698 RIDGEWOOD ROAD	FROM UNION CROSS RD (SR 2643) TO OLD HIGHPOINT RD (SR 1003)	1.607	24	17,450		19,454	754	312	60	105		58				33	6					780	880	2	2	
9CR.20341.130	Forsyth	6	SR 1152 PHILLIPS BRIDGE ROAD	FROM COUNTRY CLUB RD. (SR 1001) TO STYERS FERRY RD. (SR 1103)	1.409	20	15,161		14,879																680	680			
9CR.20341.130	Forsyth	7	SR 2758 BARNES ROAD	FROM PAVT JT AT SOUTH MAIN ST. (SR 4205) TO PAVT JT. AT OLD LEXINGTON RD. (SR 2743)	1.43	24	15,387		19,165	638	524								5	3					210	210			
9CR.20341.130	Forsyth	8	SR 1672 WEST HANES MILL ROAD	FROM RR CROSSING TO UNIVERSITY PKWY (SR 4000)	1.33	36	383		14,799	1,410	160	547	1,416	50	324		2	4	47	4			3	4	470	470			
9CR.20341.130	Forsyth	9	SR 1463 SEWARD ROAD	FROM SEWARD CIRCLE (SR 1460) TO VIENNA-DOZER ROAD (SR 1465)	2.736	22	29,439		28,892																				
9CR.20341.130	Forsyth	10	SR 2983 FISHEL ROAD	FROM STOP BAR @ NC 150 (PETERS CREEK PKWY.) TO SOUTH MAIN STREET (SR 4205)	2.14	20	23,026		22,598						50										460	460			
9CR.20341.130	Forsyth	11	SR 2967 DARWICK ROAD	FROM OLD SALISBURY ROAD (SR 3011) TO EBERT ROAD (SR 2902)	2.123	21	22,843		24,569	266	193								3										
9CR.20341.130	Forsyth	12	SR 1449 KECOUGHTAN ROAD	YADKINVILLE ROAD (SR 1525) TO SKYLARK (SR 1447)	0.762	22	8,047		8,047																				
<b>TOTAL FOR PROJ NO. 9CR.20341.130</b>							<b>18.876</b>		<b>180,252</b>		<b>211,932</b>	<b>3,361</b>	<b>1,256</b>	<b>607</b>	<b>1,521</b>	<b>50</b>	<b>661</b>	<b>12</b>	<b>2</b>	<b>4</b>	<b>117</b>	<b>15</b>	<b>2</b>	<b>5</b>	<b>4</b>	<b>4,975</b>	<b>2,700</b>	<b>2</b>	<b>2</b>
									<b>180,252</b>	<b>215,293</b>	<b>1,863</b>							<b>18</b>		<b>143</b>				<b>7,675</b>		<b>4</b>			
<b>GRAND TOTAL</b>					<b>25.966</b>		<b>255,122</b>	<b>1,725</b>	<b>295,864</b>	<b>4,455</b>	<b>2,633</b>	<b>607</b>	<b>1,521</b>	<b>50</b>	<b>980</b>	<b>12</b>	<b>2</b>	<b>4</b>	<b>137</b>	<b>16</b>	<b>2</b>	<b>5</b>	<b>4</b>	<b>4,975</b>	<b>2,700</b>	<b>2</b>	<b>2</b>	<b>468</b>	
									<b>256,847</b>	<b>300,319</b>	<b>3,240</b>							<b>18</b>		<b>164</b>			<b>7,675</b>		<b>4</b>				

NOTE: All Quantities listed include turn lanes and are estimates; Payment will be based on actual field measurements and quantities received.