

STATE	STATE PROJECT REFERENCE NO.	SHEET NO.	TOTAL SHEETS
N.C.	B-3638	1	
STATE PROJ. NO.	F.A. PROJ. NO.	DESCRIPTION	
33186.1.1	BRSTP-70B(2)	P.E.	
33186.2.1	BRSTP-70B(2)	RW & Util	
33186.3.1	BRSTP-70B(2)	CONSTR	

STATE OF NORTH CAROLINA
DIVISION OF HIGHWAYS

DURHAM COUNTY

**LOCATION: BRIDGE NO. 316 OVER CAMPUS DRIVE
ON US 70 BUSINESS**

**TYPE OF WORK: GRADING, PAVING, DRAINAGE
& STRUCTURE**

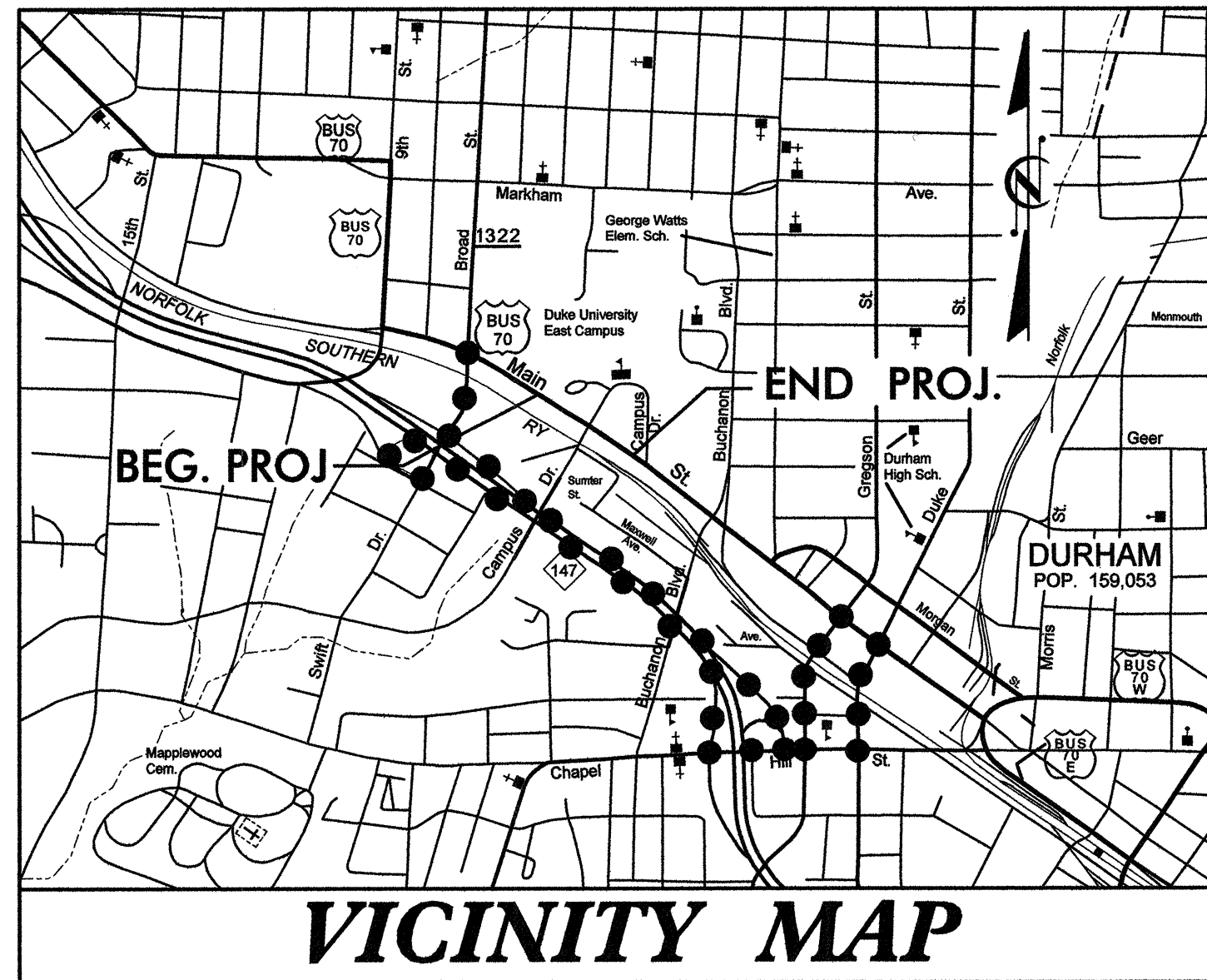

●●●●●●●● DENOTES DETOUR ROUTE

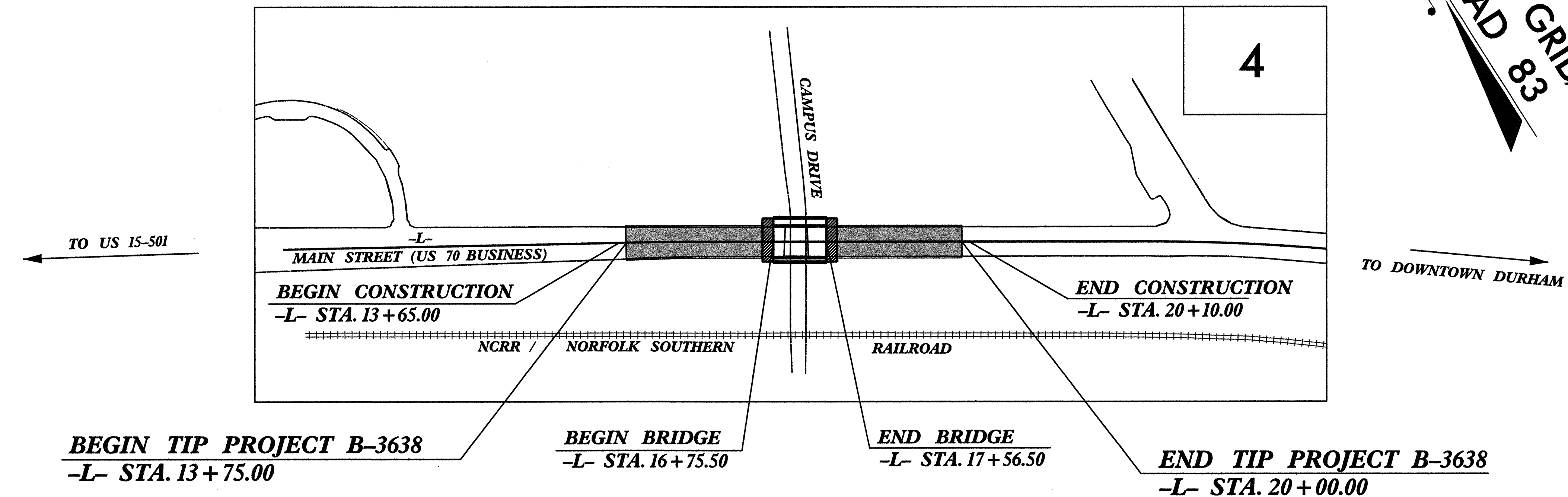
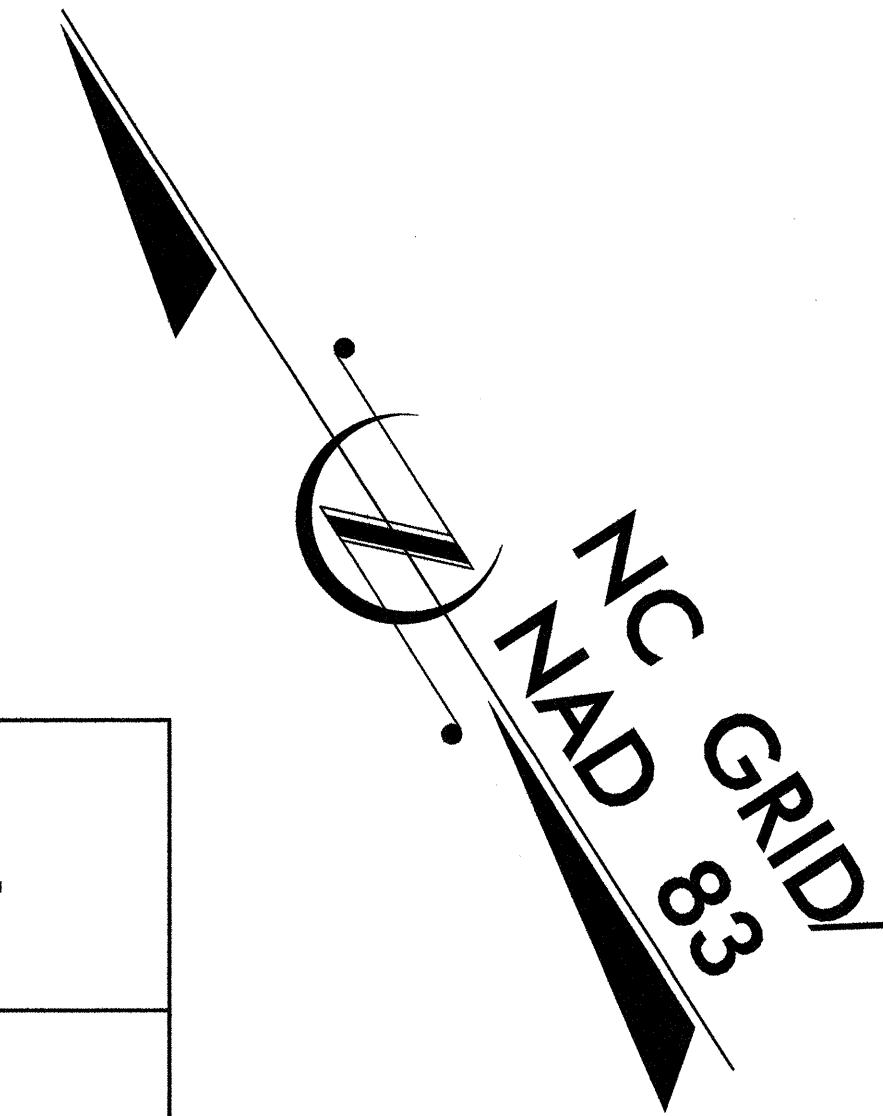

NCDOT CONTACT: BRENDA L. MOORE, P.E.
ROADWAY DESIGN - ENGINEERING COORDINATION

TIP PROJECT: B-3638

CONTRACT:

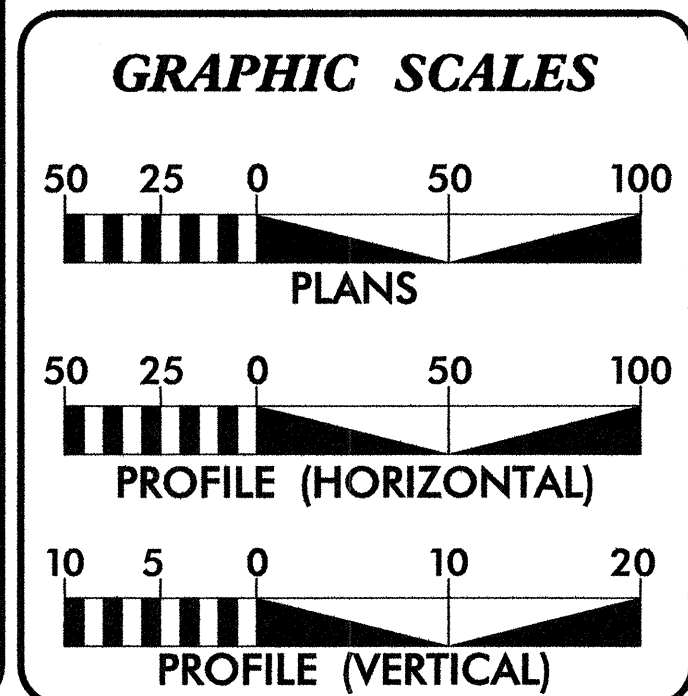

DESIGN DATA
URBAN MINOR ARTERIAL

ADT 2012	=	13,000
ADT 2035	=	22,400
DHV	=	10 %
D	=	55 %
T	=	5 % *
V	=	40 MPH
* TTST 2% DUAL 3%		
TIER CLASS. - REGIONAL		

PROJECT LENGTH

LENGTH ROADWAY TIP PROJECT B-3638	=	0.103 MI.
LENGTH STRUCTURES TIP PROJECT B-3638	=	0.015 MI.
TOTAL LENGTH OF TIP PROJECT B-3638	=	0.118 MI.

Prepared in the Office of:
Florence & Hutcheson
CONSULTING ENGINEERS
5121 Kingston Way, Suite 300 Raleigh, NC 27607
919 833-3333

2012 STANDARD SPECIFICATIONS

RIGHT OF WAY DATE: June 18, 2010

LETTING DATE: April 17, 2012

DAVID C. WALLER, P.E.
PROJECT ENGINEER

MICHAEL A. YOUNG, P.E.
PROJECT DESIGN ENGINEER

HYDRAULICS ENGINEER

Signature: *Sheldon Foltz*

Signature: *D.C. Waller*

ROADWAY DESIGN ENGINEER

Professional Engineer Seals for David C. Waller and Michael A. Young.

DIVISION OF HIGHWAYS
STATE OF NORTH CAROLINA















STATE HIGHWAY DESIGN ENGINEER

STATE OF NORTH CAROLINA
DIVISION OF HIGHWAYS











CONVENTIONAL PLAN SHEET SYMBOLS

Note: Not to Scale
*S.U.E. = Subsurface Utility Engineering











BOUNDARIES AND PROPERTY:

State Line	_____
County Line	_____
Township Line	_____
City Line	_____
Reservation Line	_____
Property Line	_____
Existing Iron Pin	_____ 
Property Corner	_____ 
Property Monument	_____ 
Parcel/Sequence Number	_____ 
Existing Fence Line	_____ 
Proposed Woven Wire Fence	_____ 
Proposed Chain Link Fence	_____ 
Proposed Barbed Wire Fence	_____ 
Existing Wetland Boundary	_____ 
Proposed Wetland Boundary	_____ 
Existing Endangered Animal Boundary	_____ 
Existing Endangered Plant Boundary	_____ 
Known Soil Contamination: Area or Site	_____ 
Potential Soil Contamination: Area or Site	_____ 





BUILDINGS AND OTHER CULTURE:

Gas Pump Vent or U/G Tank Cap	_____ 
Sign	_____ 
Well	_____ 
Small Mine	_____ 
Foundation	_____ 
Area Outline	_____ 
Cemetery	_____ 
Building	_____ 
School	_____ 
Church	_____ 
Dam	_____ 

















HYDROLOGY:

Stream or Body of Water	_____
Hydro, Pool or Reservoir	_____ 
Jurisdictional Stream	_____ 
Buffer Zone 1	_____ 
Buffer Zone 2	_____ 
Flow Arrow	_____ 
Disappearing Stream	_____ 
Spring	_____ 
Wetland	_____ 
Proposed Lateral, Tail, Head Ditch	_____ 
False Sump	_____ 











RAILROADS:

Standard Gauge	_____ 
RR Signal Milepost	_____ 
Switch	_____ 
RR Abandoned	_____ 
RR Dismantled	_____ 





RIGHT OF WAY:



Baseline Control Point	_____ 
Existing Right of Way Marker	_____ 
Existing Right of Way Line	_____ 
Proposed Right of Way Line	_____ 
Proposed Right of Way Line with Iron Pin and Cap Marker	_____ 
Proposed Right of Way Line with Concrete or Granite Marker	_____ 
Existing Control of Access	_____ 
Proposed Control of Access	_____ 
Existing Easement Line	_____ 
Proposed Temporary Construction Easement	_____ 
Proposed Temporary Drainage Easement	_____ 
Proposed Permanent Drainage Easement	_____ 
Proposed Permanent Drainage / Utility Easement	_____ 
Proposed Permanent Utility Easement	_____ 
Proposed Temporary Utility Easement	_____ 
Proposed Aerial Utility Easement	_____ 

ROADS AND RELATED FEATURES:









Existing Edge of Pavement	_____ 
Existing Curb	_____ 
Proposed Slope Stakes Cut	_____ 
Proposed Slope Stakes Fill	_____ 
Proposed Curb Ramp	_____ 
Existing Metal Guardrail	_____ 
Proposed Guardrail	_____ 
Existing Cable Guiderail	_____ 
Proposed Cable Guiderail	_____ 
Equality Symbol	_____ 
Pavement Removal	_____ 

VEGETATION:











Single Tree	_____ 
Single Shrub	_____ 
Hedge	_____ 
Woods Line	_____ 

Orchard	_____ 
Vineyard	_____ 













EXISTING STRUCTURES:

MAJOR:	
Bridge, Tunnel or Box Culvert	_____ 
Bridge Wing Wall, Head Wall and End Wall	_____ 
MINOR:	
Head and End Wall	_____ 
Pipe Culvert	_____ 
Footbridge	_____ 
Drainage Box: Catch Basin, DI or JB	_____ 
Paved Ditch Gutter	_____ 
Storm Sewer Manhole	_____ 
Storm Sewer	_____ 







UTILITIES:

POWER:	
Existing Power Pole	_____ 
Proposed Power Pole	_____ 
Existing Joint Use Pole	_____ 
Proposed Joint Use Pole	_____ 
Power Manhole	_____ 
Power Line Tower	_____ 
Power Transformer	_____ 
U/G Power Cable Hand Hole	_____ 
H-Frame Pole	_____ 
Recorded U/G Power Line	_____ 
Designated U/G Power Line (S.U.E.*)	_____ 









TELEPHONE:

Existing Telephone Pole	_____ 
Proposed Telephone Pole	_____ 
Telephone Manhole	_____ 
Telephone Booth	_____ 
Telephone Pedestal	_____ 
Telephone Cell Tower	_____ 
U/G Telephone Cable Hand Hole	_____ 
Recorded U/G Telephone Cable	_____ 
Designated U/G Telephone Cable (S.U.E.*)	_____ 
Recorded U/G Telephone Conduit	_____ 
Designated U/G Telephone Conduit (S.U.E.*)	_____ 
Recorded U/G Fiber Optics Cable	_____ 
Designated U/G Fiber Optics Cable (S.U.E.*)	_____ 





WATER:

Water Manhole	_____ 
Water Meter	_____ 
Water Valve	_____ 
Water Hydrant	_____ 
Recorded U/G Water Line	_____ 
Designated U/G Water Line (S.U.E.*)	_____ 
Above Ground Water Line	_____ 







TV:

TV Satellite Dish	_____ 
TV Pedestal	_____ 
TV Tower	_____ 
U/G TV Cable Hand Hole	_____ 
Recorded U/G TV Cable	_____ 
Designated U/G TV Cable (S.U.E.*)	_____ 
Recorded U/G Fiber Optic Cable	_____ 
Designated U/G Fiber Optic Cable (S.U.E.*)	_____ 













GAS:

Gas Valve	_____ 
Gas Meter	_____ 
Recorded U/G Gas Line	_____ 
Designated U/G Gas Line (S.U.E.*)	_____ 
Above Ground Gas Line	_____ 

SANITARY SEWER:

Sanitary Sewer Manhole	_____ 
Sanitary Sewer Cleanout	_____ 
U/G Sanitary Sewer Line	_____ 
Above Ground Sanitary Sewer	_____ 
Recorded SS Forced Main Line	_____ 
Designated SS Forced Main Line (S.U.E.*)	_____ 

MISCELLANEOUS:

Utility Pole	_____ 
Utility Pole with Base	_____ 
Utility Located Object	_____ 
Utility Traffic Signal Box	_____ 
Utility Unknown U/G Line	_____ 
U/G Tank; Water, Gas, Oil	_____ 
Underground Storage Tank, Approx. Loc.	_____ 
A/G Tank; Water, Gas, Oil	_____ 
Geoenvironmental Boring	_____ 
U/G Test Hole (S.U.E.*)	_____ 
Abandoned According to Utility Records	_____ 
End of Information	_____ 

SURVEY CONTROL SHEET B-3638

DURHAM COUNTY

LOCATION: Bridge No. 316 over Campus Drive on US70 (Main Street)

B-3638

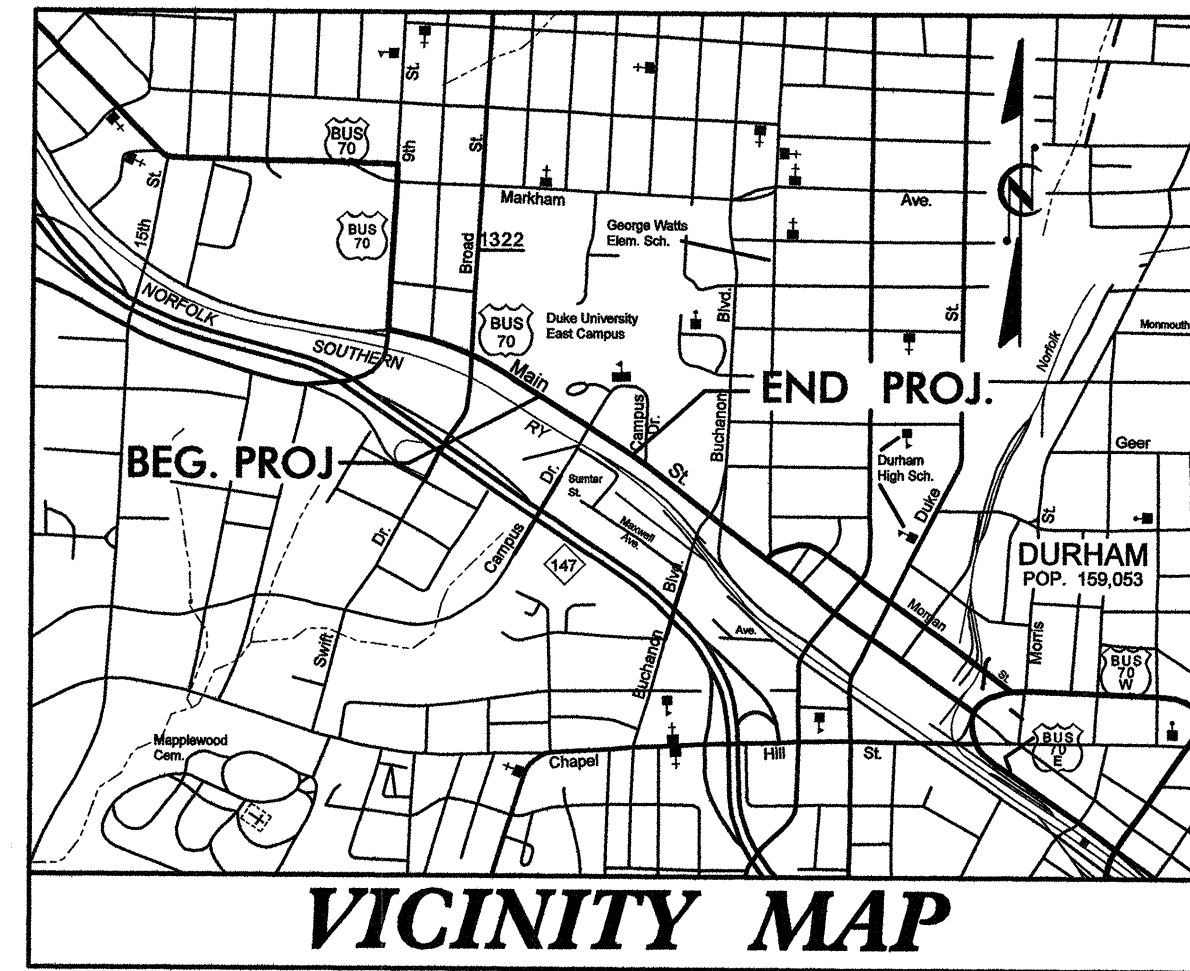

THIS PROJECT IS WITHIN THE MUNICIPAL BOUNDARIES OF DURHAM.

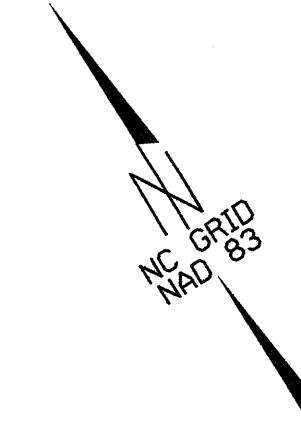

DATUM DESCRIPTION

THE LOCALIZED COORDINATE SYSTEM DEVELOPED FOR THIS PROJECT IS BASED ON THE STATE PLANE COORDINATES ESTABLISHED BY NCDOT FOR MONUMENT "SWITCH"
 WITH NAD 83 STATE PLANE GRID COORDINATES OF
 NORTHING: 820965.4970(±) EASTING: 2023793.7110(±)
 THE AVERAGE COMBINED GRID FACTOR USED ON THIS PROJECT (GROUND TO GRID) IS: 0.999940194
 THE N.C. LAMBERT GRID BEARING AND LOCALIZED HORIZONTAL GROUND DISTANCE FROM "SWITCH" TO -L- STATION IS
 S 63°48'07" W 707.04'
 ALL LINEAR DIMENSIONS ARE LOCALIZED HORIZONTAL DISTANCES
 VERTICAL DATUM USED IS NGVD 29

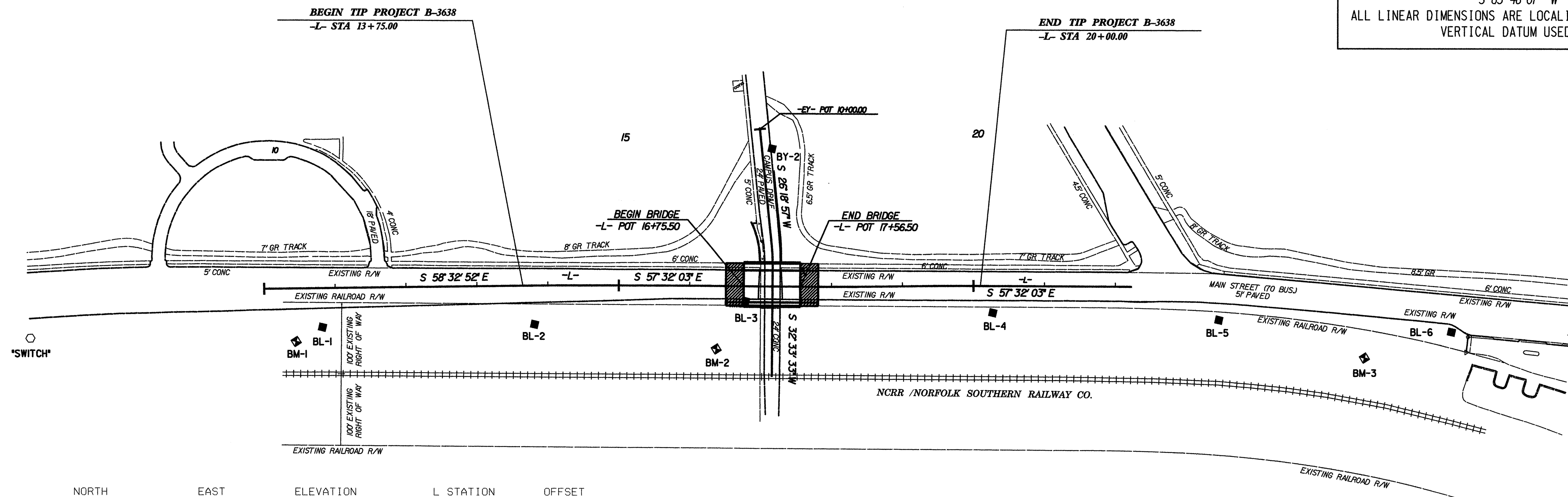

CONTROL DATA

BL POINT	DESC.	NORTH	EAST	ELEVATION	L STATION	OFFSET
201	BL-1	820759.5150	2024149.0620	414.44	10+81.54	55.04 RT
202	BL-2	820603.5680	2024405.7760	407.93	13+81.95	54.13 RT
203	BL-3	820473.4090	2024673.7690	400.78	16+78.85	20.89 RT
204	BL-4	820273.4100	2024960.4200	409.92	20+28.08	38.08 RT
205	BL-5	820096.0260	2025224.5700	416.80	OUTSIDE PROJECT LIMITS	
206	BL-6	819906.5760	2025493.1500	414.49	OUTSIDE PROJECT LIMITS	

BY POINT	DESC.	NORTH	EAST	ELEVATION	Y STATION	OFFSET
302	BY-2	820635.8380	2024819.6190	382.01	13+20.60	14.11 RT
301	BY-1	820140.0840	2024485.4060	396.22	OUTSIDE PROJECT LIMITS	

BENCHMARKS

222	ELEVATION = 416.28	225	ELEVATION = 417.65
BM1		BM3	
N 820761	E 2024109	N 819941	E 2025371
L STATION 10+46 75 RIGHT		L STATION 22+23	
RR SPIKE IN BASE OF 15" CEDAR TREE		S 40° 55' 42.7" E DIST 343.99	
		RR SPIKE IN BASE OF 16" CEDAR TREE	
223	ELEVATION = 402.89		
BM2			
N 820436	E 2024605		
L STATION 16+41 89 RIGHT			
RR SPIKE IN BASE OF 12" CEDAR TREE			

NOTES:

1. THE CONTROL DATA FOR THIS PROJECT CAN BE FOUND ELECTRONICALLY BY SELECTING PROJECT CONTROL DATA AT:
[HTTP://WWW.DOHDOT.STATE.NC.US/PRECONSTRUCT/HIGHWAY/LOCATION/PROJECT/](http://www.doh.dot.state.nc.us/preconstruct/highway/location/project/)
 THE FILES TO BE FOUND ARE AS FOLLOWS:
 B3638_LS_CONTROL_081002.TXT

SITE CALIBRATION INFORMATION HAS NOT BEEN PROVIDED FOR THIS PROJECT. IF FURTHER INFORMATION IS NEEDED, PLEASE CONTACT THE LOCATION AND SURVEYS UNIT.
 ○ INDICATES GEODETIC CONTROL MONUMENTS USED OR SET FOR HORIZONTAL PROJECT CONTROL BY THE NCDOT LOCATION AND SURVEYS UNIT.
 PROJECT CONTROL ESTABLISHED USING GLOBAL POSITIONING SYSTEM.
 NETWORK ESTABLISHED FROM NGS ONLINE POSITIONING SERVICE (OPUS)
 SEE GPS CALIBRATION SHEET FOR HORIZONTAL AND VERTICAL COORDINATE VALUES.

NOTE: DRAWING NOT TO SCALE

10/10/2008

K:\9\2012\Projects\Durham\B3638\1s_1b_081002.dgn

6/2/99

FINAL PAVEMENT SCHEDULE			
C1	PROP. APPROX. 3" ASPHALT CONCRETE SURFACE COURSE, TYPE S9.5B, AT AN AVERAGE RATE OF 168 LBS. PER SQ. YD. IN EACH OF TWO LAYERS.	R1	8" x 12" GRANITE CURB
C2	PROP. VAR. DEPTH ASPHALT CONCRETE SURFACE COURSE, TYPE S9.5B, AT AN AVERAGE RATE OF 112 LBS. PER SQ. YD. PER 1" DEPTH. TO BE PLACED IN LAYERS NOT TO EXCEED 2" IN DEPTH.	S1	4" CONCRETE SIDEWALK
D1	PROP. APPROX. 4" ASPHALT CONCRETE INTERMEDIATE COURSE, TYPE I19.0B, AT AN AVERAGE RATE OF 456 LBS. PER SQ. YD.	T	EARTH MATERIAL.
D2	PROP. VAR. DEPTH ASPHALT CONCRETE INTERMEDIATE COURSE, TYPE I19.0B, AT AN AVERAGE RATE OF 114 LBS. PER SQ. YD. PER 1" DEPTH. TO BE PLACED IN LAYERS NOT LESS THAN 2 1/2" IN DEPTH OR GREATER THAN 4" IN DEPTH.	U	EXISTING PAVEMENT.
E1	PROP. APPROX. 4" ASPHALT CONCRETE BASE COURSE, TYPE B25.0B, AT AN AVERAGE RATE OF 456 LBS. PER SQ. YD.	W	VARIABLE DEPTH ASPHALT PAVEMENT
E2	PROP. VAR. DEPTH ASPHALT CONCRETE BASE COURSE, TYPE B25.0B, AT AN AVERAGE RATE OF 114 LBS. PER SQ. YD. PER 1" DEPTH. TO BE PLACED IN LAYERS NOT LESS THAN 3" IN DEPTH OR GREATER THAN 6 1/2" IN DEPTH.		

FH Florence & Hutcheson
 CONSULTING ENGINEERS
 5121 Kingdom Way, Suite 100 Raleigh, NC 27607
 NC License No. F-0258

PROJECT REFERENCE NO. B-3638	SHEET NO. 2
ROADWAY DESIGN ENGINEER <i>[Signature]</i>	PAVEMENT DESIGN ENGINEER <i>[Signature]</i>
SEAL 22606 DAVID C. WALKER	SEAL 22896 CLARK S. MORRISON

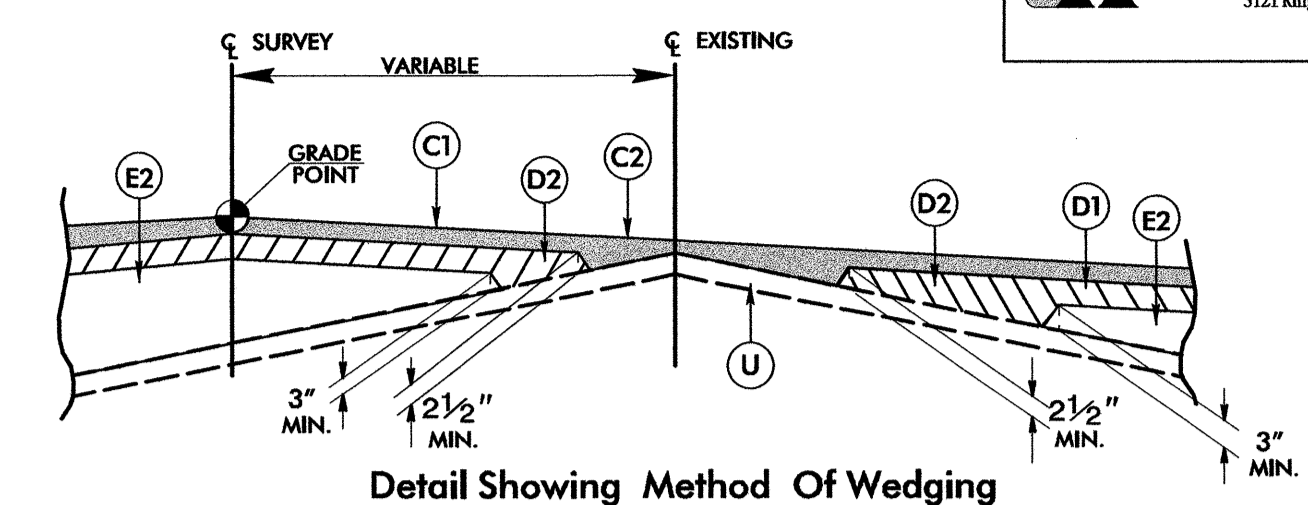

NOTE: PAVEMENT EDGE SLOPES ARE 1:1 UNLESS SHOWN OTHERWISE.

* FOR GUARDRAIL LOCATION, SEE PLANS

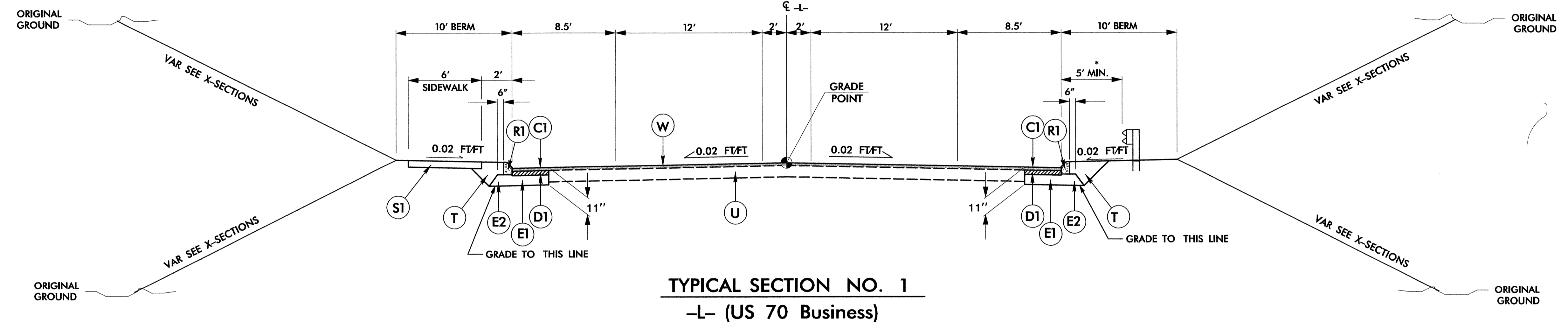

USE TYPICAL SECTION NO. 1
 -L- STA.13+75.00 TO 15+75.00
 -L- STA. 18+75.00 TO 20+00.00

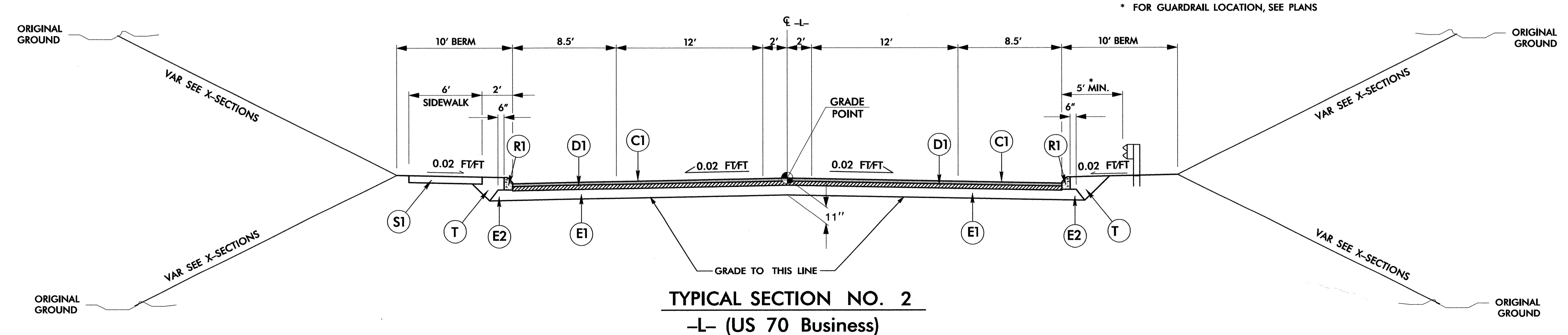

USE TYPICAL SECTION NO. 2
 -L- STA. 15+75.00 TO 16+75.50 (BRIDGE)
 -L- STA. 17+56.50 (BRIDGE) TO 18+75.00

3/2/2012
 R:\Roadway\Projects\3638_rdy-typ.dgn
 Florence & Hutcheson, Inc.

6/2/99

FH Florence & Hutcheson
 CONSULTING ENGINEERS
 5121 Kingston Way, Suite 100 Raleigh, NC 27607
 NC License No: P-0258

PROJECT REFERENCE NO. B-3638	SHEET NO. 2-A
ROADWAY DESIGN ENGINEER	PAVEMENT DESIGN ENGINEER

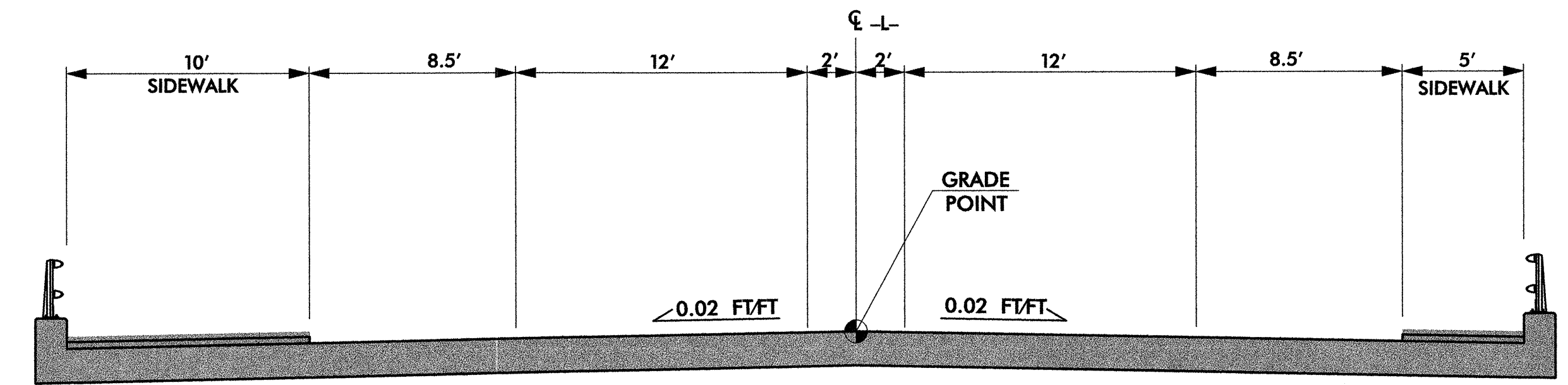

USE TYPICAL SECTION NO. 3
 -L- STA. 16+75.50 (BRIDGE) TO 17+56.50 (BRIDGE)

TYPICAL SECTION NO. 3
-L- (US 70 Business)
BRIDGE

K3/2012
 FH Roadway\Proj\B3638_rdy_typ.dgn
 Florence & Hutcheson, Inc.

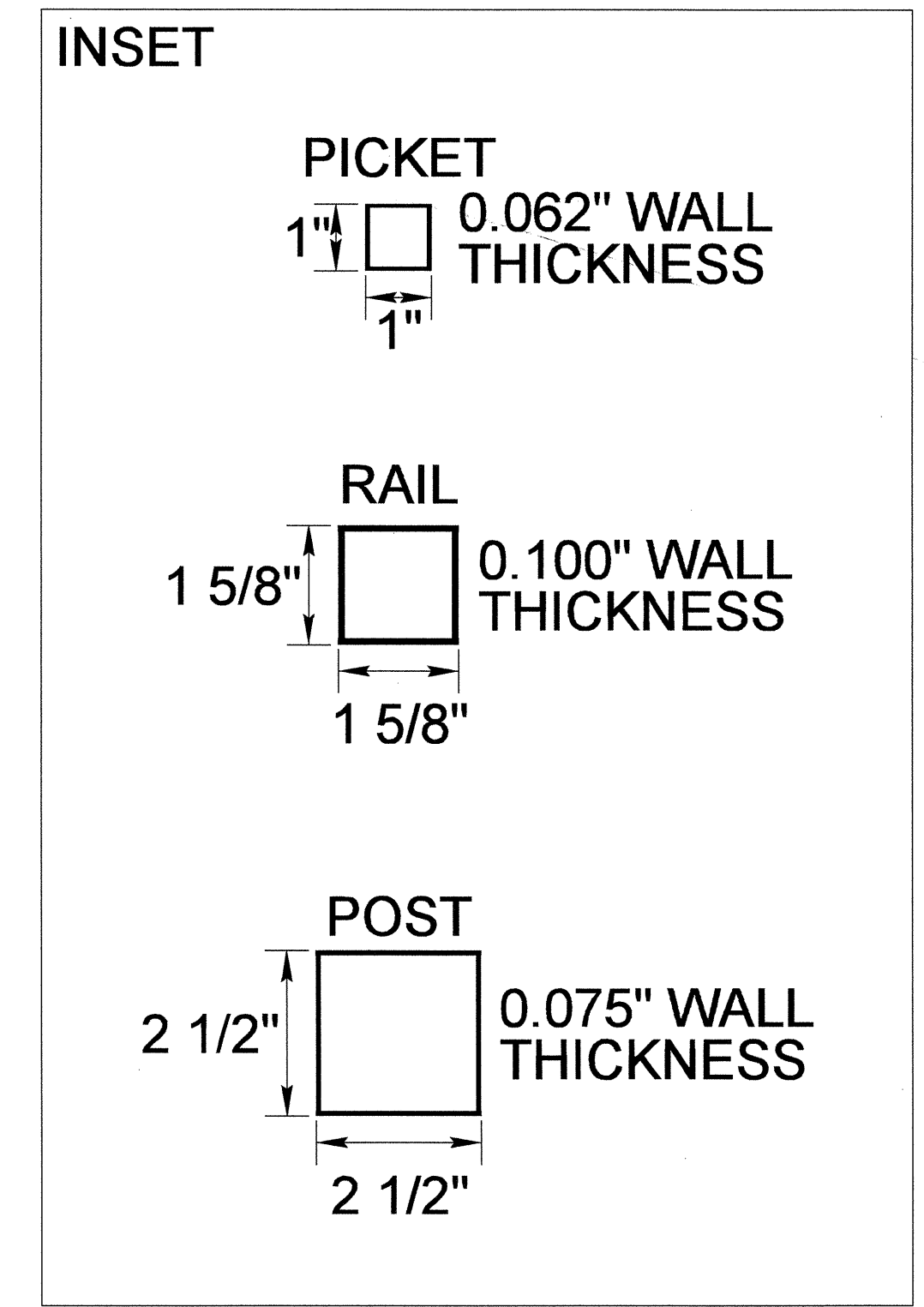
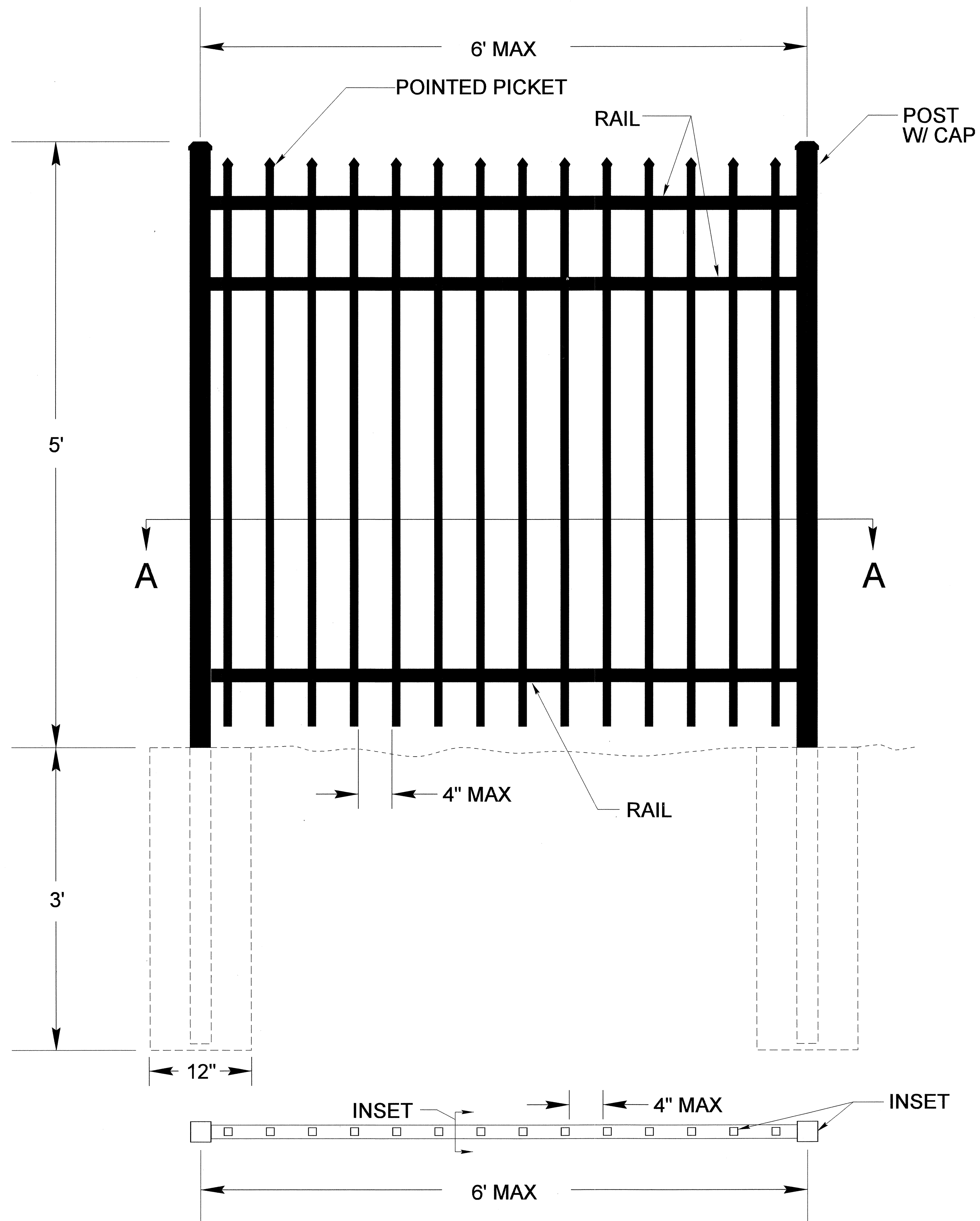

- NOTES:
- 1) SUBMIT ALTERNATE FENCE MATERIAL TO ENGINEER FOR APPROVAL.
 - 2) SUBMIT ANY VARIATIONS IN FENCE DIMENSIONS TO ENGINEER FOR APPROVAL.
 - 3) POST MAY BE DRIVEN IF IT CAUSES NO STRUCTURAL DAMAGE. (SEE MANUFACTURERS RECOMMENDATIONS)

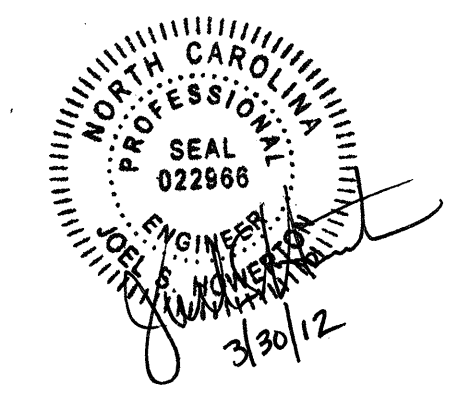

CONTRACT STANDARDS AND DEVELOPMENT UNIT	
Office 919-707-6950 FAX 919-250-4119	
ALUMINUM ORNAMENTAL FENCE	
ORIGINAL BY: K KEMPF	DATE: 4-2009
MODIFIED BY: <i>[Signature]</i>	DATE: 2/17/12
CHECKED BY: <i>[Signature]</i>	DATE: 2/17/12
FILE SPEC: <i>[Signature]</i>	

SECTION A-A

I:\FEB-2012 14:30
 S:\CONTRACTS\Special_Details\kempf\english\ornamental_fence.dgn
 \$\$\$USER\$NAME\$\$\$

SUMMARY OF EARTHWORK IN CUBIC YARDS

LOCATION	UNCLASSIFIED EXCAVATION	UNDERCUT	EMBT + %	BORROW	WASTE
SUMMARY NO. 1					
-L- 14+80 TO 16+75.50 (BRIDGE)	22		1060	1038	
TOTAL SUMMARY NO. 1	22		1060	1038	
SUMMARY NO. 2					
-L- 17+56.50 (BRIDGE) TO 19+50	17		725	708	
TOTAL SUMMARY NO. 2	17		725	708	
SUB-TOTAL SUMMARY NOS. 1 & 2	39		1785	1746	
PROJECT TOTALS	39		1785	1746	
EST. FOR REPLACING TOPSOIL ON BORROW PITS				87	
GRAND TOTALS	39		1785	1833	
SAY	50			1840	

8" x 12" GRANITE CURB

8" X 12" GRANITE CURB				
SURVEY LINE	STATION	STATION	LOCATION LT/RT/CL	NET LENGTH
-L-	13+65	16+51	LT	286
-L-	13+65	16+51	RT	286
-L-	17+81	20+00	LT	219
-L-	17+81	20+00	RT	219
			TOTAL:	1010
			SAY:	1010

CONTINGENCY UNDERCUT PER GEOTECH RECS DATED 01/07/09 = 260 CY
 SELECT GRANULAR MATERIAL PER GEOTECH RECS DATED 01/07/09 = 100 CY
 SHALLOW UNDERCUT PER GEOTECH RECS DATED 01/07/09 = 100 CY
 CLASS IV SUBGRADE STABILIZATION PER GEOTECH RECS DATED 01/07/09 = 100 TONS
 FABRIC FOR SOIL STABILIZATION PER GEOTECH RECS DATED 01/07/09 = 200 SY

Note: Approximate quantities only. Unclassified Excavation, Fine Grading, Clearing and Grubbing, Removal of Existing Pavement, and Breaking of Existing Pavement will be paid for at the contract lump sum price for "Grading."

Note: Earthwork quantities are calculated by the Roadway Design Unit. These earthwork quantities are based in part on subsurface data provided by the Geotechnical Engineering Unit.

PAVEMENT REMOVAL / BREAKING SUMMARY

PAVEMENT REMOVAL					PAVEMENT BREAKING				
SURVEY LINE	STATION	STATION	LOCATION LT/RT/CL	YD ²	SURVEY LINE	STATION	STATION	LOCATION LT/RT/CL	YD ²
-L-	16+26	16+97	LT & RT	319.50	-L-	15+75	16+26	LT & RT	229.50
-L-	17+28	18+06	LT & RT	353.25	-L-	18+06	18+75	LT & RT	310.50
			TOTAL:	672.75				TOTAL:	540.00
			SAY:	680				SAY:	540

GUARDRAIL SUMMARY

"N" = DISTANCE FROM EDGE OF LANE TO FACE OF GUARDRAIL.
 TOTAL SHOULDER WIDTH = DISTANCE FROM EDGE OF TRAVEL LANE TO SHOULDER BREAK POINT.
 FLARE LENGTH = DISTANCE FROM LAST SECTION OF PARALLEL GUARDRAIL TO END OF GUARDRAIL.
 W = TOTAL WIDTH OF FLARE FROM BEGINNING OF TAPER TO END OF GUARDRAIL.
 G = GATING IMPACT ATTENUATOR TYPE 350
 NG = NON-GATING IMPACT ATTENUATOR TYPE 350

SURVEY LINE	BEG. STA.	END STA.	LOCATION	LENGTH			WARRANT POINT		"N" DIST. FROM E.O.L.	TOTAL SHOUL. WIDTH	FLARE LENGTH		W		ANCHORS									IMPACT ATTENUATOR TYPE 350	SINGLE FACED GUARDRAIL	REMOVE EXISTING GUARDRAIL	REMOVE AND STOCKPILE EXISTING GUARDRAIL	REMARKS												
				STRAIGHT	SHOP CURVED	DOUBLE FACED	APPROACH END	TRAILING END			APPROACH END	TRAILING END	XI MOD	XI	GRAU 350	M-350	TYPE III	CAT-1	VI MOD	BIC	AT-1	EA	G						NG											
-L-	15+20.75	16+64.50	RT	143.75					7	8	75.00		1.5																											
SUB TOTAL				143.75																																				
GRAND TOTAL				75.00																																				
SAY				75.00																																				

23-MAR-2012 14:02 C:\Documents and Settings\btKyle\Local Settings\Temporary Internet Files\Content.Outlook\LZPCI50\b3638_rdy_sum_earthwork.dgn

8.17.99

-L-

PI Sta 14+27.68	PI Sta 18+37.21	PI Sta 19+50.31
$\Delta = 1'00'' 48.7''$ (RT)	$\Delta = 1'10'' 26.3''$ (LT)	$\Delta = 1'10'' 26.3''$ (RT)
D = 1'02' 16.7"	D = 1'02' 16.7"	D = 1'02' 16.7"
L = 97.65'	L = 113.0'	L = 113.0'
T = 48.82'	T = 56.55'	T = 56.55'
R = 5,520.00'	R = 5,520.00'	R = 5,520.00'

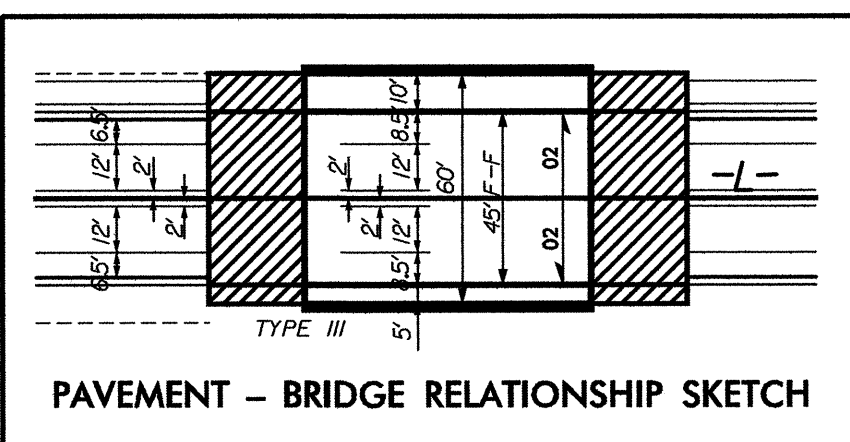

INSTALL CURB RAMP AT EXISTING CROSSWALK. SALVAGE GRANITE CURBSTONES FOR RETENTION BY DUKE UNIVERSITY.

-EY-

PI Sta 11+79.37
 $\Delta = 6'14'' 35.8''$ (RT)
 D = 22' 00' 00.0"
 L = 28.38'
 T = 14.20'
 R = 260.44'

Florence & Hutcheson
 CONSULTING ENGINEERS
 5121 Kingsland Way, Suite 100 Raleigh, NC 27607
 NC License No: F0255

DETAIL A
 TOE PROTECTION
 (Not to Scale)
 24" OR FLATTER
 1/4" Slope
 d= 1Ft.
 Type of Liner= PSRM
 FROM STA. 14+50 TO STA. 16+50 -L- RT.

PROJECT REFERENCE NO. B-3638	SHEET NO. 4
RW SHEET NO.	HYDRAULICS ENGINEER
ROADWAY DESIGN ENGINEER	SEAL 22606 DAVID C. WALLER 3-21-12
	SEAL 19732 STITCHEN 3-21-2012

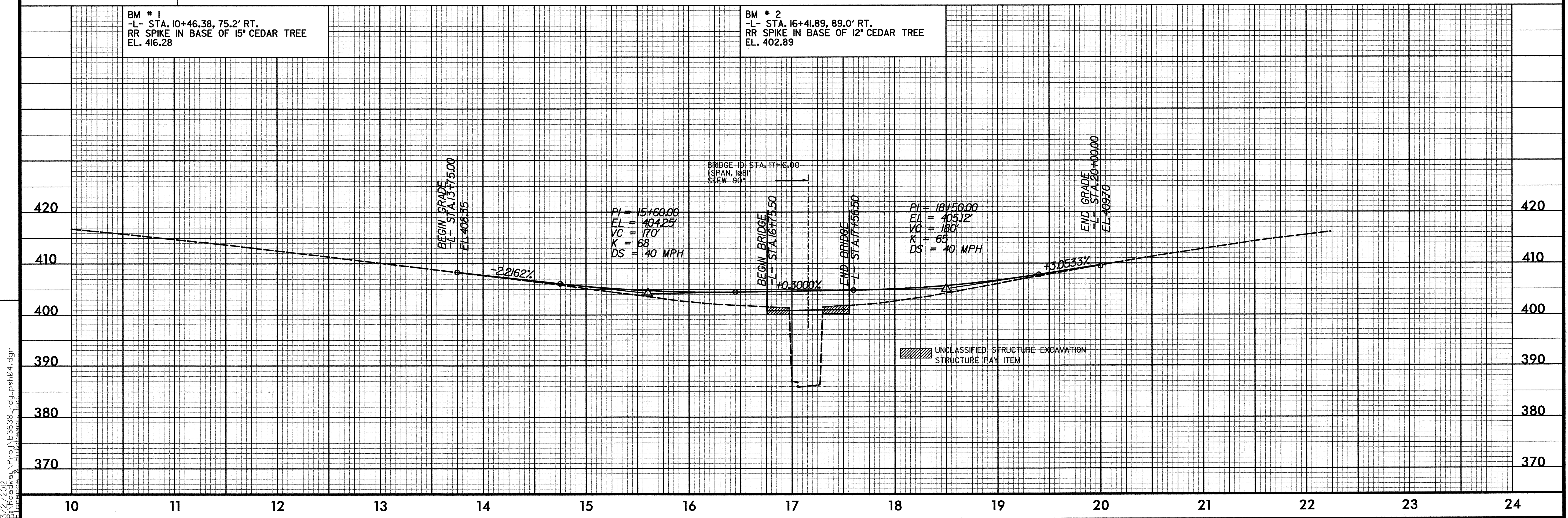
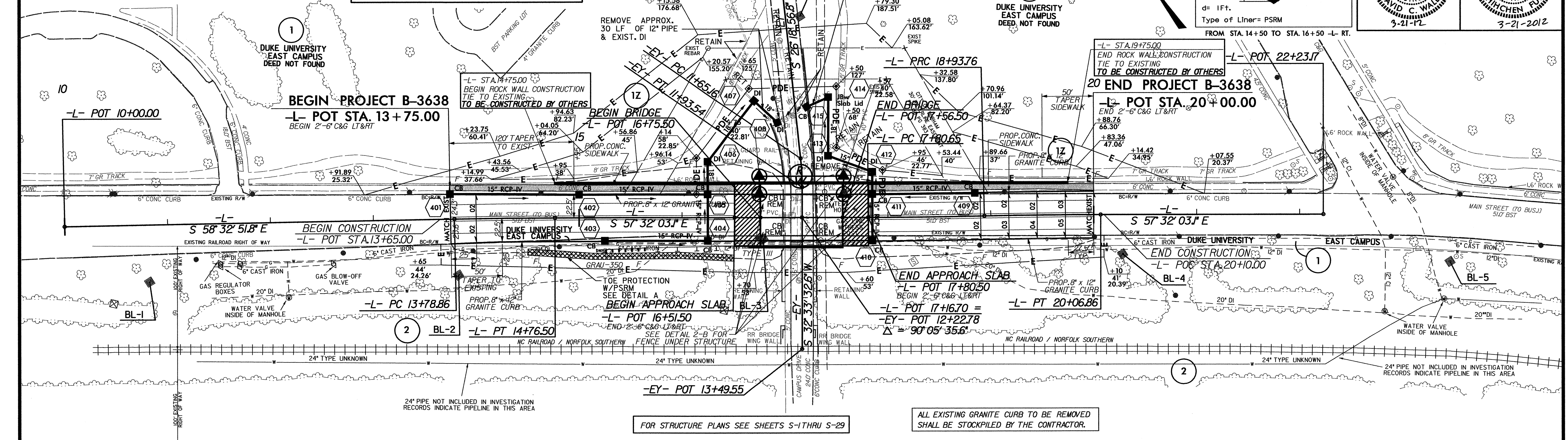

REVISIONS

3/21/2012
R:\Roadway\Projects\B3638-rdy-psn04.dgn
Florence & Hutcheson, Inc.