

STATE	STATE PROJECT REFERENCE NO.	SHEET NO.	TOTAL SHEETS
N.C.	R-5522	1	
STATE PROJ. NO.	F.A. PROJ. NO.	DESCRIPTION	
45547.1.1	APD-1113(9)	P.E.	
45547.2.1	APD-1113(9)	RW	
45547.3.1	APD-1113(9)	CONST.	

STATE OF NORTH CAROLINA
DIVISION OF HIGHWAYS

RUTHERFORD COUNTY

**LOCATION: BRIDGE OVER CSX RAILROAD ON
RELOCATED SR 1113 (HICKS GROVE ROAD)
BETWEEN US 221 & EXIST. SR 1113**

TYPE OF WORK: GRADING, DRAINAGE, PAVING AND STRUCTURE

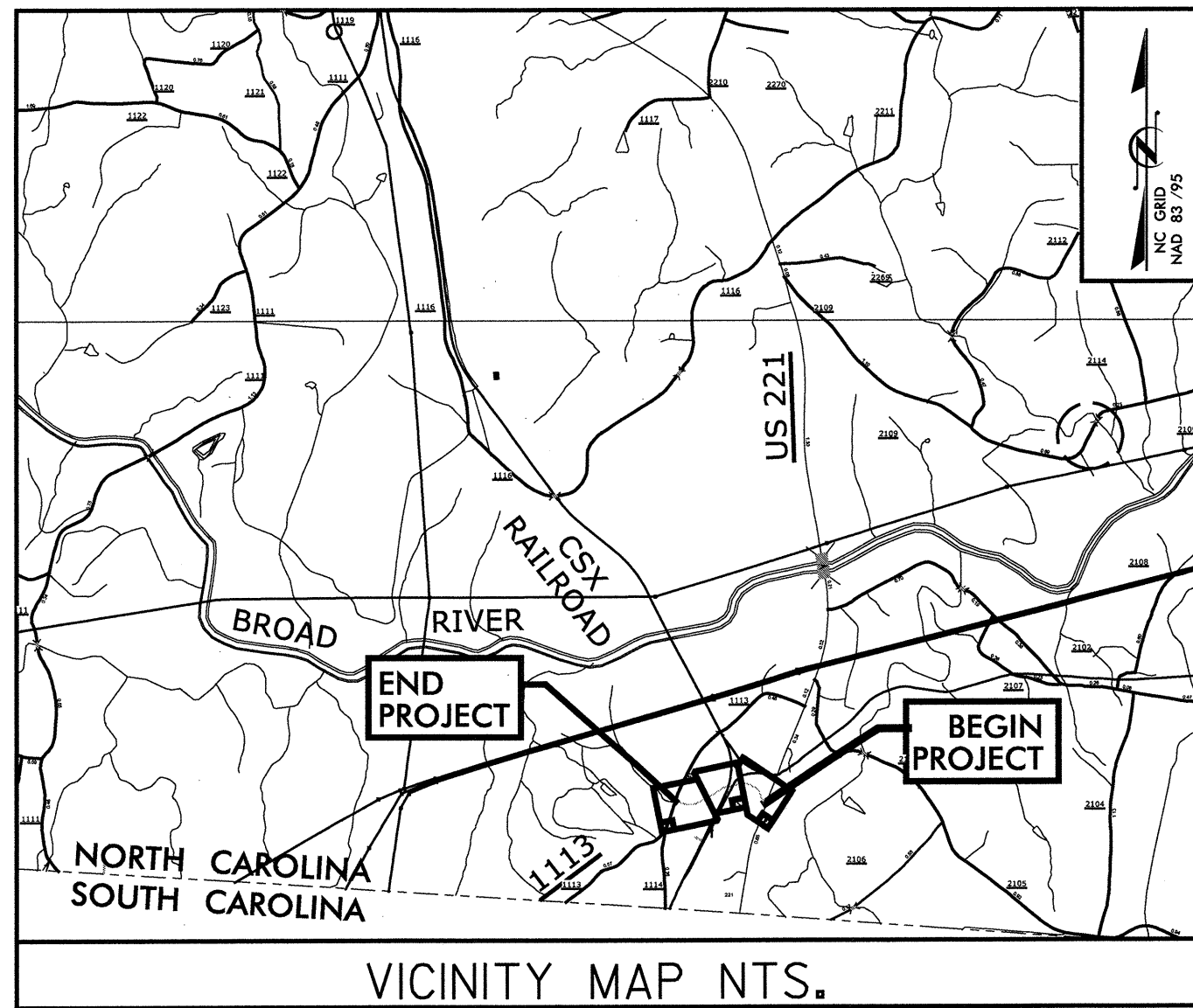

SEE SHEET I-A FOR INDEX OF SHEETS

ADJACENT PROJECT
R-2233AA -L- Sta. 37+05.770 =
BEGIN TIP PROJECT R-5522
-L- POT STA. 10+00.000

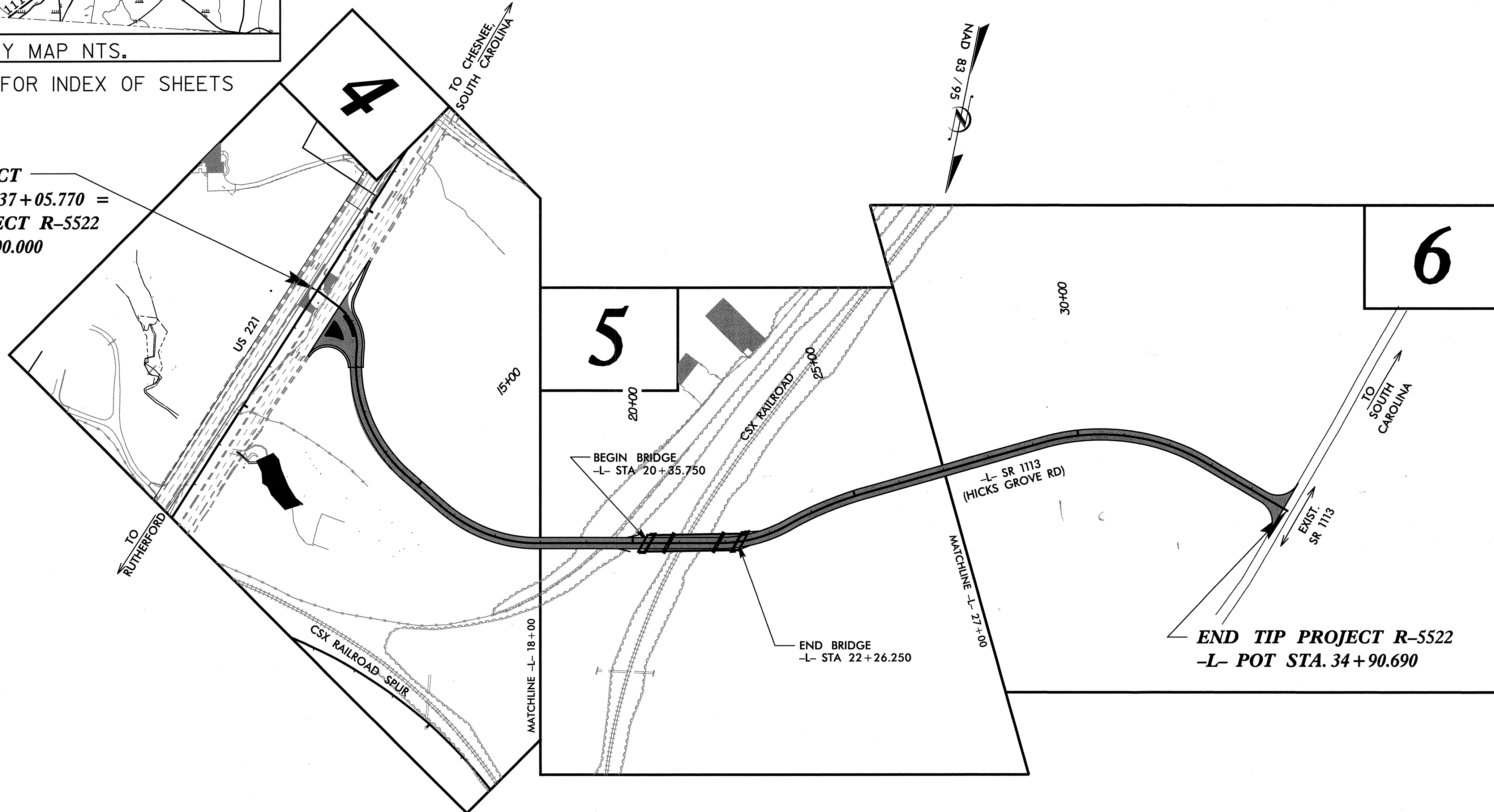

END TIP PROJECT R-5522
-L- POT STA. 34+90.690

V&M
Vaughn & Melton
Consulting Engineers

Charlotte, North Carolina 704-856-9081
Tri-Cities, Tennessee 423-467-8401
Knoxville, Tennessee 865-646-8800
Middleboro, Kentucky 606-248-6600
Asheville, North Carolina 828-253-2796
Spartanburg, South Carolina 864-574-4775

Copyright © 1994 Vaughn & Melton, Inc.
All Rights Reserved

GRAPHIC SCALES

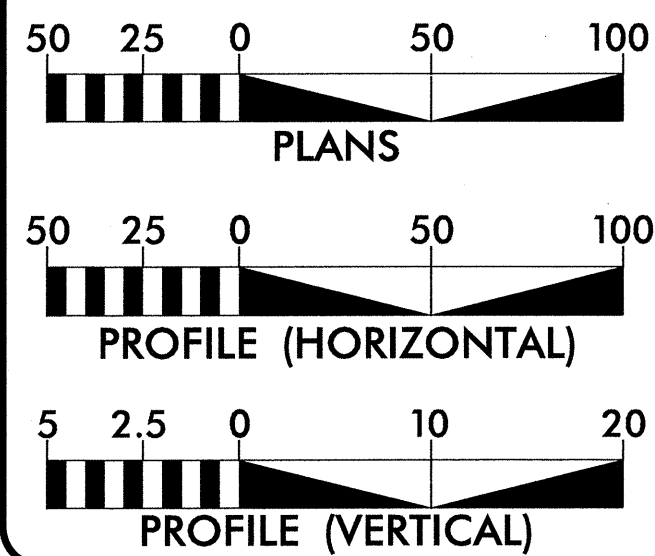

DESIGN DATA

ADT 2005 = 500
ADT 2030 = 1600
DHV
D
T = 6 %
V = 35 MPH
FUNC CLASS = RURAL LOCAL

PROJECT LENGTH

LENGTH ROADWAY PROJECT TIP R-5522 = 0.436 MI
LENGTH STRUCTURE PROJECT TIP R-5522 = 0.036 MI
TOTAL LENGTH OF PROJECT TIP R-5522 = 0.472 MI

Prepared In the Office of:
VAUGHN & MELTON
1318-F PATTON AVE.
ASHEVILLE NC, 28806
FOR THE NORTH CAROLINA DIVISION OF HIGHWAYS

2012 STANDARD SPECIFICATIONS

RIGHT OF WAY DATE:

LETTING DATE:
MAY 15, 2012

REECE SCHULER, PE
PROJECT ENGINEER

JIM MILLER, EI
PROJECT DESIGN ENGINEER

NC DOT CONTACT:
DOUG McNEAL, PE
DIVISION 13 DISTRICT ENGINEER

HYDRAULICS ENGINEER

Signature: [Signature]
Professional Engineer Seal: AROM C. CARROLL, P.E., No. 030453, State of North Carolina

ROADWAY DESIGN ENGINEER
Signature: [Signature]
Professional Engineer Seal: REECE M. SCHULER, P.E., No. 28890, State of North Carolina

**DIVISION OF HIGHWAYS
STATE OF NORTH CAROLINA**

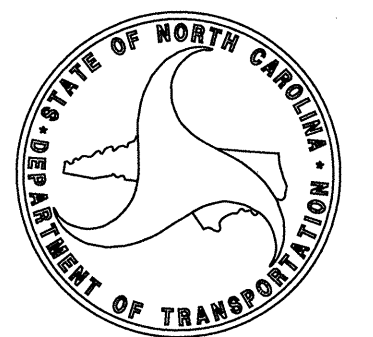

STATE HIGHWAY DESIGN ENGINEER

CONTRACT: C203044 TIP PROJECT: R-5522

\$\$\$\$\$SYTIME\$\$\$\$\$DGN\$\$\$\$\$SERNAME\$\$\$\$\$

02/17/12













Note: Not to Scale

*S.U.E. = Subsurface Utility Engineering











STATE OF NORTH CAROLINA
DIVISION OF HIGHWAYS

CONVENTIONAL PLAN SHEET SYMBOLS











BOUNDARIES AND PROPERTY:

- State Line _____
- County Line _____
- Township Line _____
- City Line _____
- Reservation Line _____
- Property Line _____
- Existing Iron Pin _____ 
- Property Corner _____ 
- Property Monument _____ 
- Parcel/Sequence Number _____ 
- Existing Fence Line _____ 
- Proposed Woven Wire Fence _____ 
- Proposed Chain Link Fence _____ 
- Proposed Barbed Wire Fence _____ 
- Existing Wetland Boundary _____ 
- Proposed Wetland Boundary _____ 
- Existing Endangered Animal Boundary _____ 
- Existing Endangered Plant Boundary _____ 



BUILDINGS AND OTHER CULTURE:

- Gas Pump Vent or U/G Tank Cap _____ 
- Sign _____ 
- Well _____ 
- Small Mine _____ 
- Foundation _____ 
- Area Outline _____ 
- Cemetery _____ 
- Building _____ 
- School _____ 
- Church _____ 
- Dam _____ 





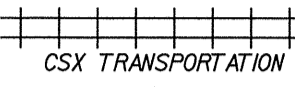
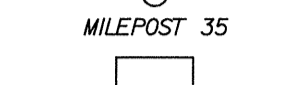
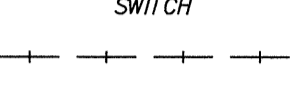



HYDROLOGY:

- Stream or Body of Water _____ 
- Hydro, Pool or Reservoir _____ 
- Jurisdictional Stream _____ 
- Buffer Zone 1 _____ 
- Buffer Zone 2 _____ 
- Flow Arrow _____ 
- Disappearing Stream _____ 
- Spring _____ 
- Wetland _____ 
- Proposed Lateral, Tail, Head Ditch _____ 
- False Sump _____ 



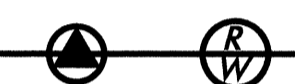
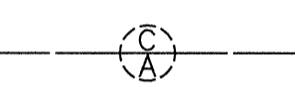

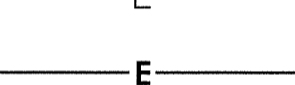
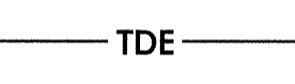
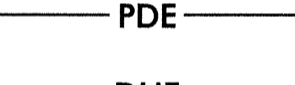
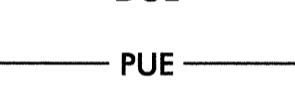
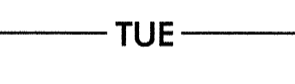

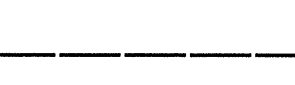
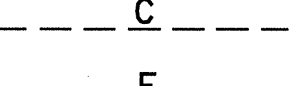
RAILROADS:

- Standard Gauge _____ 
- RR Signal Milepost _____ 
- Switch _____ 
- RR Abandoned _____ 
- RR Dismantled _____ 

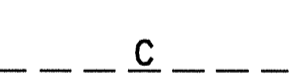
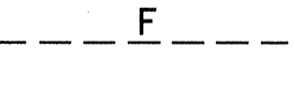

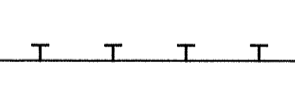
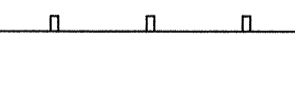

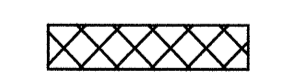
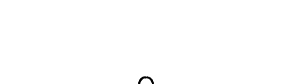
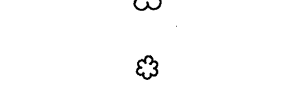
RIGHT OF WAY:

- Baseline Control Point _____ 
- Existing Right of Way Marker _____ 
- Existing Right of Way Line _____ 
- Proposed Right of Way Line _____ 
- Proposed Right of Way Line with Iron Pin and Cap Marker _____ 
- Proposed Right of Way Line with Concrete or Granite Marker _____ 
- Existing Control of Access _____ 
- Proposed Control of Access _____ 
- Existing Easement Line _____ 
- Proposed Temporary Construction Easement _____ 
- Proposed Temporary Drainage Easement _____ 
- Proposed Permanent Drainage Easement _____ 
- Proposed Permanent Drainage / Utility Easement _____ 
- Proposed Permanent Utility Easement _____ 
- Proposed Temporary Utility Easement _____ 
- Proposed Permanent Easement with Iron Pin and Cap Marker _____ 

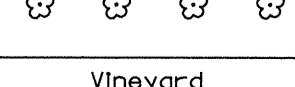

ROADS AND RELATED FEATURES:

- Existing Edge of Pavement _____ 
- Existing Curb _____ 
- Proposed Slope Stakes Cut _____ 
- Proposed Slope Stakes Fill _____ 
- Proposed Wheel Chair Ramp _____ 
- Existing Metal Guardrail _____ 
- Proposed Guardrail _____ 
- Existing Cable Guiderail _____ 
- Proposed Cable Guiderail _____ 
- Equality Symbol _____ 
- Pavement Removal _____ 





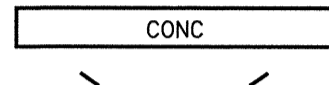
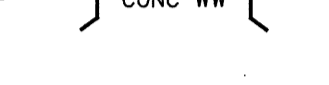
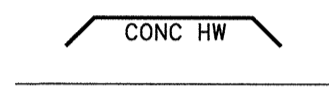
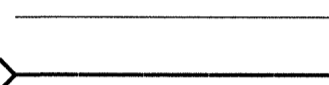
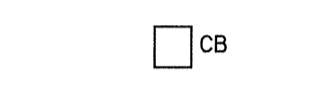
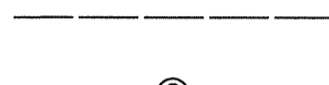
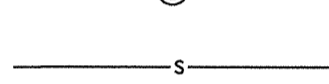

VEGETATION:

- Single Tree _____ 
- Single Shrub _____ 
- Hedge _____ 
- Woods Line _____ 
- Orchard _____ 
- Vineyard _____ 

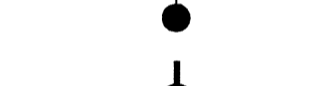

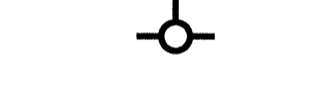

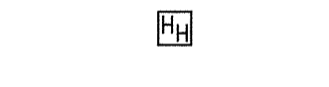
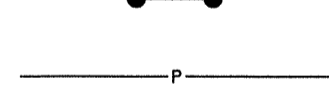
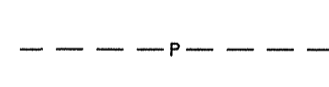

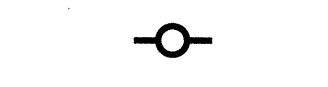
EXISTING STRUCTURES:

- MAJOR:
 - Bridge, Tunnel or Box Culvert _____ 
 - Bridge Wing Wall, Head Wall and End Wall _____ 
- MINOR:
 - Head and End Wall _____ 
 - Pipe Culvert _____ 
 - Footbridge _____ 
 - Drainage Box: Catch Basin, DI or JB _____ 
 - Paved Ditch Gutter _____ 
 - Storm Sewer Manhole _____ 
 - Storm Sewer _____ 



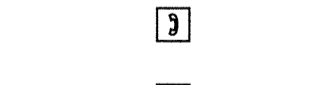
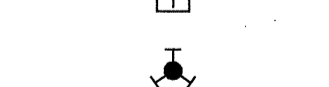

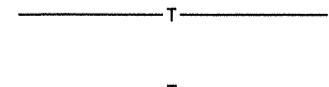
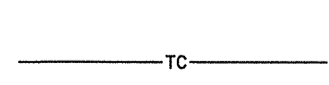
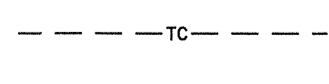
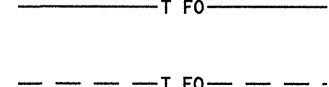
UTILITIES:

- POWER:
 - Existing Power Pole _____ 
 - Proposed Power Pole _____ 
 - Existing Joint Use Pole _____ 
 - Proposed Joint Use Pole _____ 
 - Power Manhole _____ 
 - Power Line Tower _____ 
 - Power Transformer _____ 
 - U/G Power Cable Hand Hole _____ 
 - H-Frame Pole _____ 
 - Recorded U/G Power Line _____ 
 - Designated U/G Power Line (S.U.E.*) _____ 



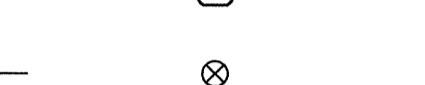

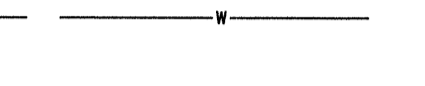
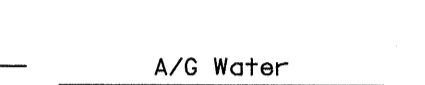
TELEPHONE:

- Existing Telephone Pole _____ 
- Proposed Telephone Pole _____ 
- Telephone Manhole _____ 
- Telephone Booth _____ 
- Telephone Pedestal _____ 
- Telephone Cell Tower _____ 
- U/G Telephone Cable Hand Hole _____ 
- Recorded U/G Telephone Cable _____ 
- Designated U/G Telephone Cable (S.U.E.*) _____ 
- Recorded U/G Telephone Conduit _____ 
- Designated U/G Telephone Conduit (S.U.E.*) _____ 
- Recorded U/G Fiber Optics Cable _____
- Designated U/G Fiber Optics Cable (S.U.E.*) _____

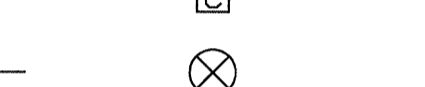

WATER:

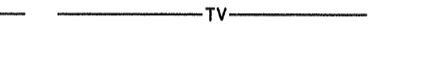
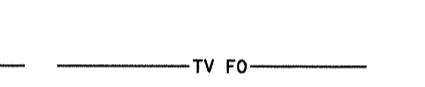
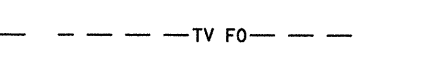
- Water Manhole _____ 
- Water Meter _____ 
- Water Valve _____ 
- Water Hydrant _____ 
- Recorded U/G Water Line _____ 
- Designated U/G Water Line (S.U.E.*) _____ 
- Above Ground Water Line _____ 

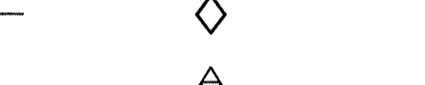
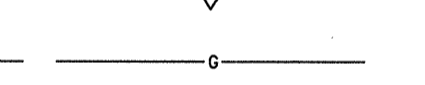
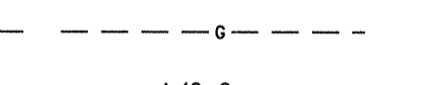

TV:

- TV Satellite Dish _____ 
- TV Pedestal _____ 
- TV Tower _____ 
- U/G TV Cable Hand Hole _____ 
- Recorded U/G TV Cable _____ 
- Designated U/G TV Cable (S.U.E.*) _____ 
- Recorded U/G Fiber Optic Cable _____ 
- Designated U/G Fiber Optic Cable (S.U.E.*) _____ 





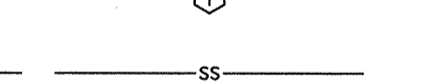
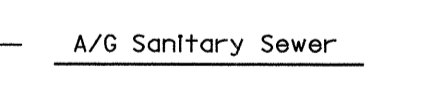
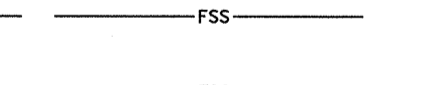

GAS:

- Gas Valve _____ 
- Gas Meter _____ 
- Recorded U/G Gas Line _____ 
- Designated U/G Gas Line (S.U.E.*) _____ 
- Above Ground Gas Line _____ 

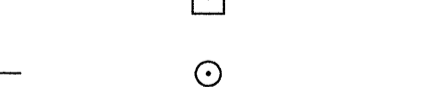
SANITARY SEWER:

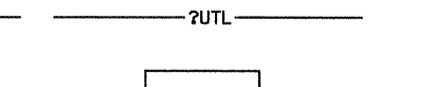
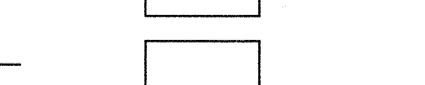
- Sanitary Sewer Manhole _____ 
- Sanitary Sewer Cleanout _____ 
- U/G Sanitary Sewer Line _____ 
- Above Ground Sanitary Sewer _____ 
- Recorded SS Forced Main Line _____ 
- Designated SS Forced Main Line (S.U.E.*) _____ 

MISCELLANEOUS:

- Utility Pole _____ 
- Utility Pole with Base _____ 
- Utility Located Object _____ 
- Utility Traffic Signal Box _____ 
- Utility Unknown U/G Line _____ 
- U/G Tank; Water, Gas, Oil _____ 
- A/G Tank; Water, Gas, Oil _____ 
- U/G Test Hole (S.U.E.*) _____ 
- Abandoned According to Utility Records _____ 
- End of Information _____

AATUR

E.O.I.

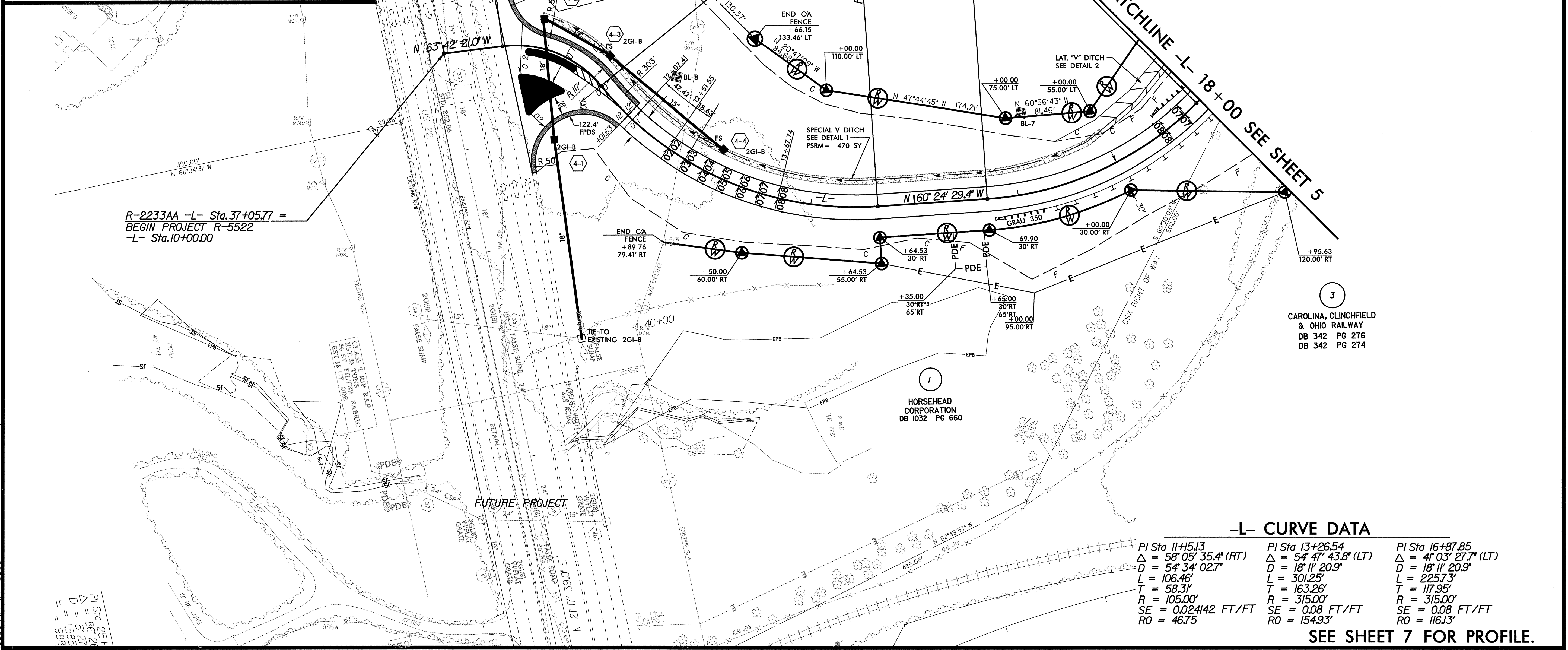
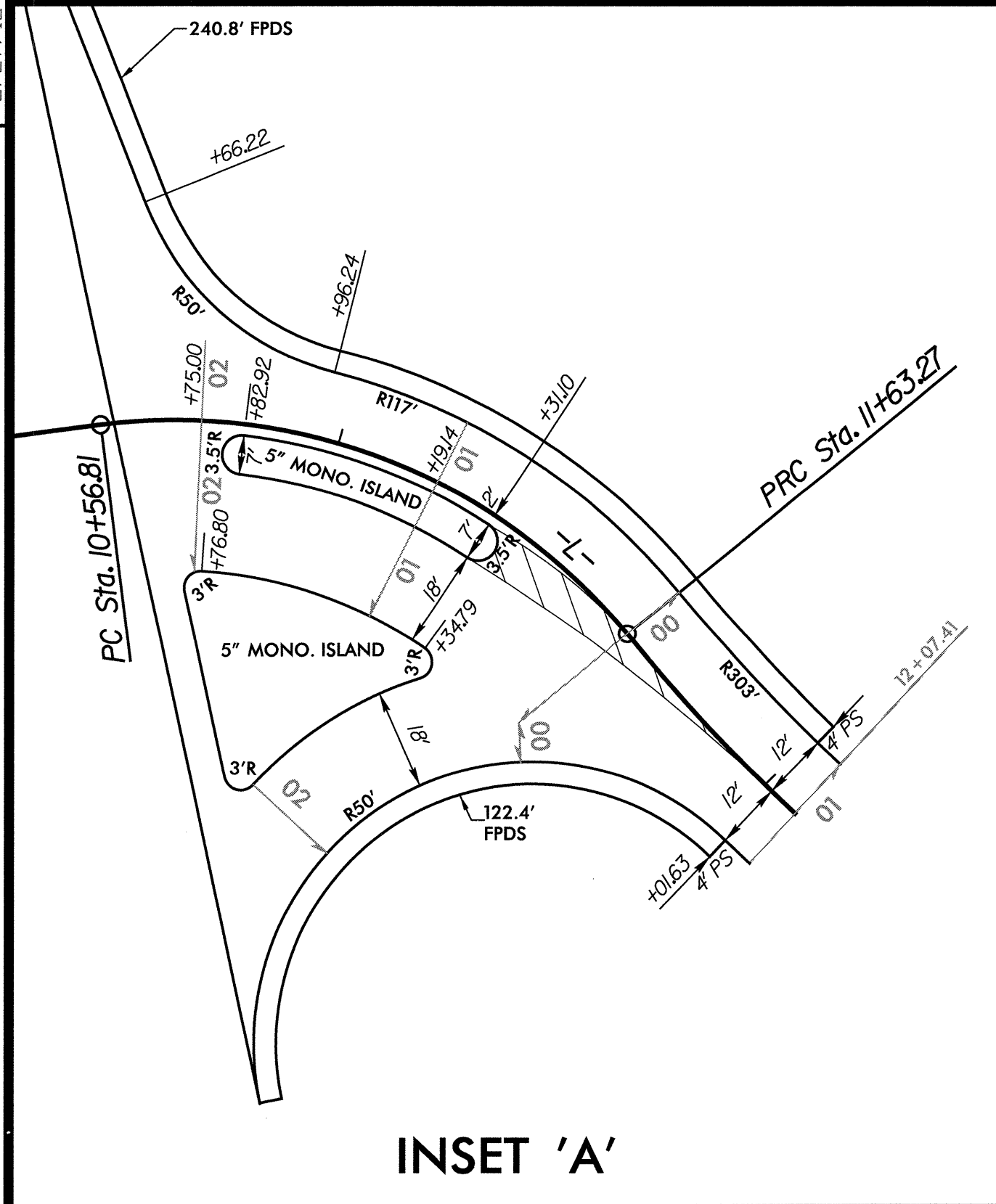
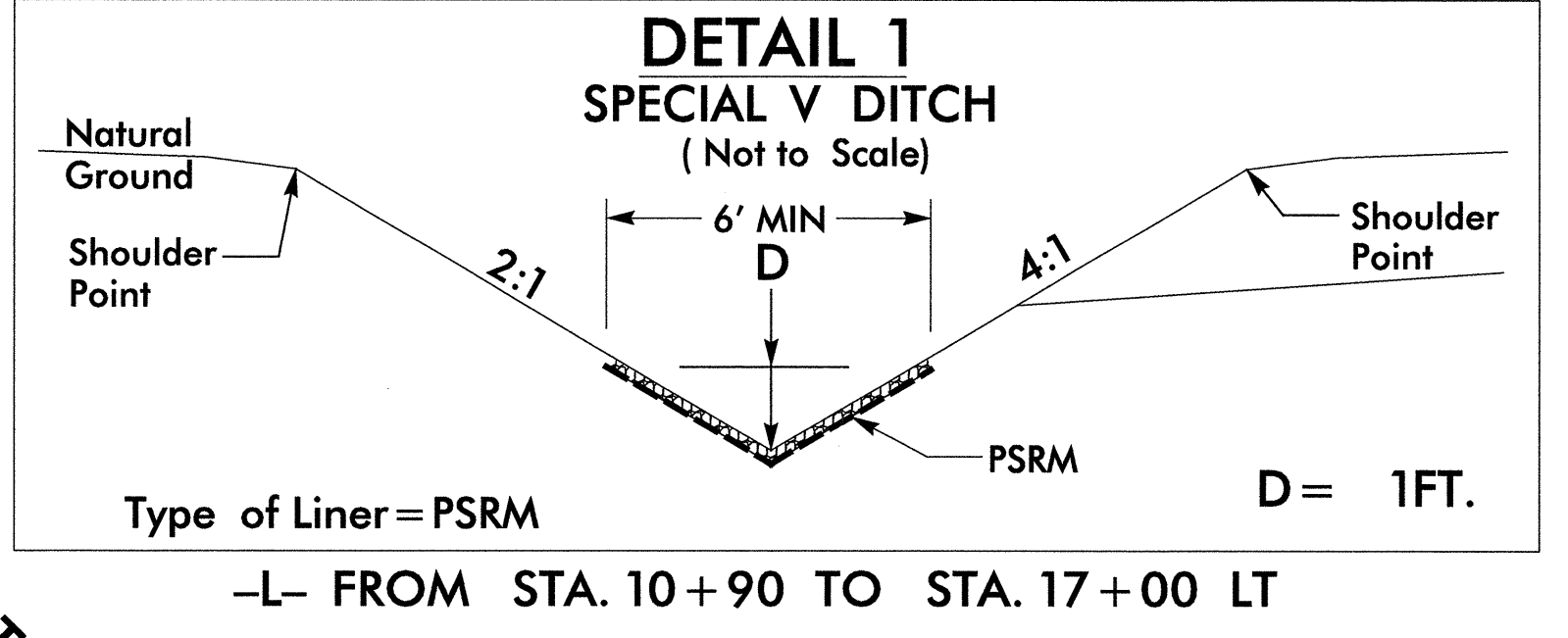
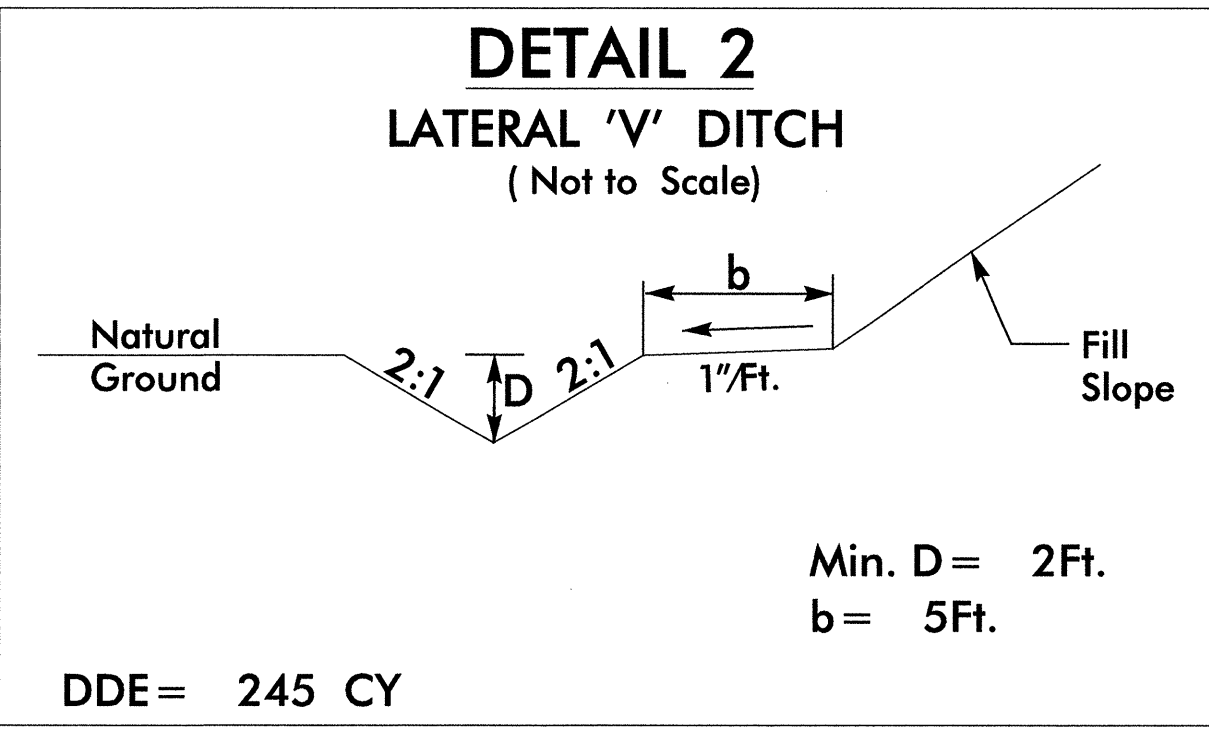
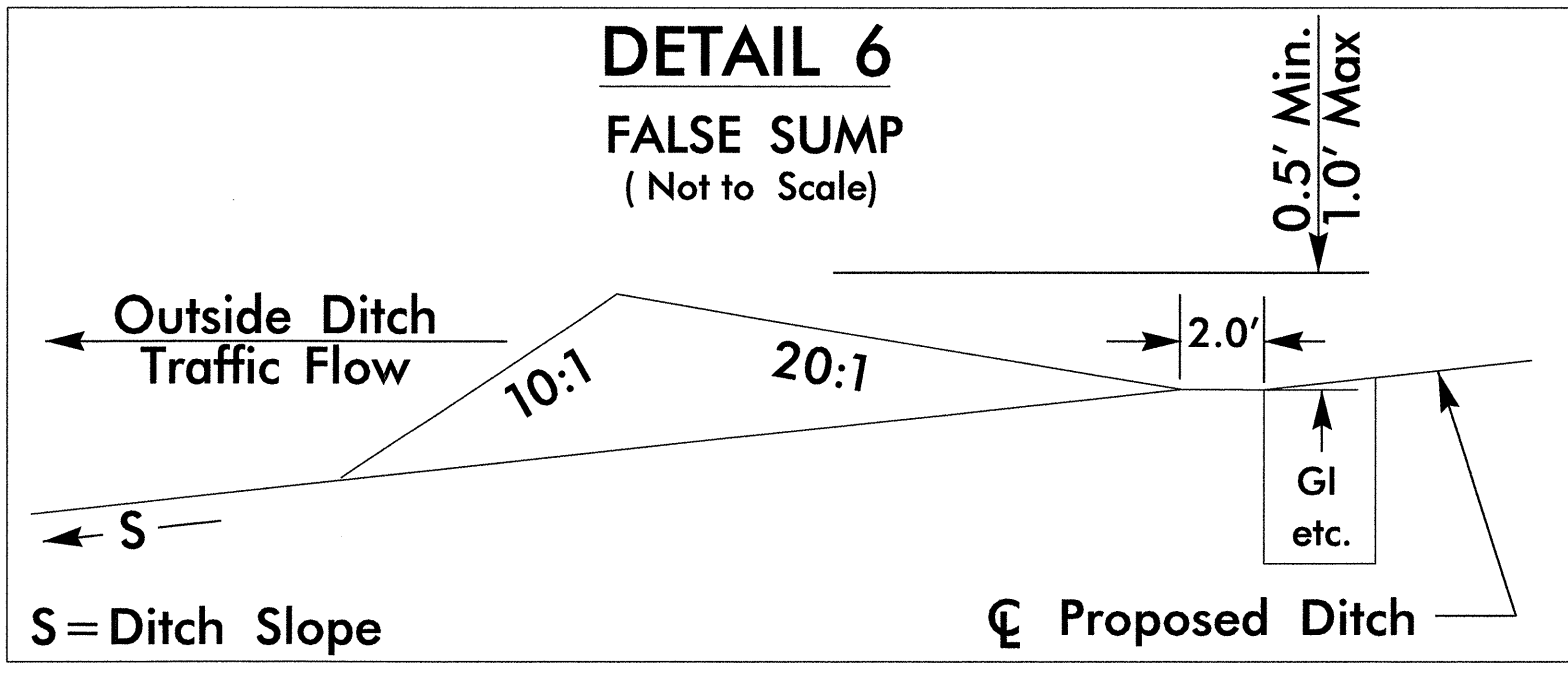

-L- CURVE DATA

PI Sta 11+51.3	PI Sta 13+26.54	PI Sta 16+87.85
$\Delta = 58^{\circ} 05' 35.4''$ (RT)	$\Delta = 54^{\circ} 47' 43.8''$ (LT)	$\Delta = 41^{\circ} 03' 27.7''$ (LT)
$D = 54^{\circ} 34' 02.7''$	$D = 18^{\circ} 11' 20.9''$	$D = 18^{\circ} 11' 20.9''$
$L = 106.46'$	$L = 301.25'$	$L = 225.73'$
$T = 58.31'$	$T = 163.26'$	$T = 117.95'$
$R = 105.00'$	$R = 315.00'$	$R = 315.00'$
$SE = 0.02442$ FT/FT	$SE = 0.08$ FT/FT	$SE = 0.08$ FT/FT
$RO = 46.75$	$RO = 154.93'$	$RO = 116.13'$

SEE SHEET 7 FOR PROFILE.

REVISIONS

2/27/12

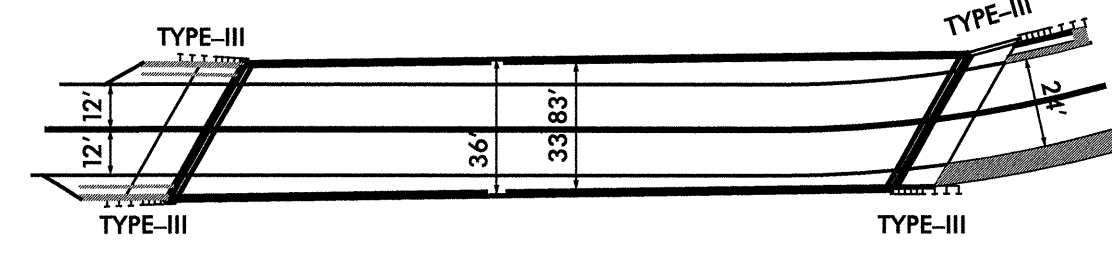

SKETCH SHOWING RELATIONSHIP OF PAVEMENT WIDTH TO BRIDGE WIDTH

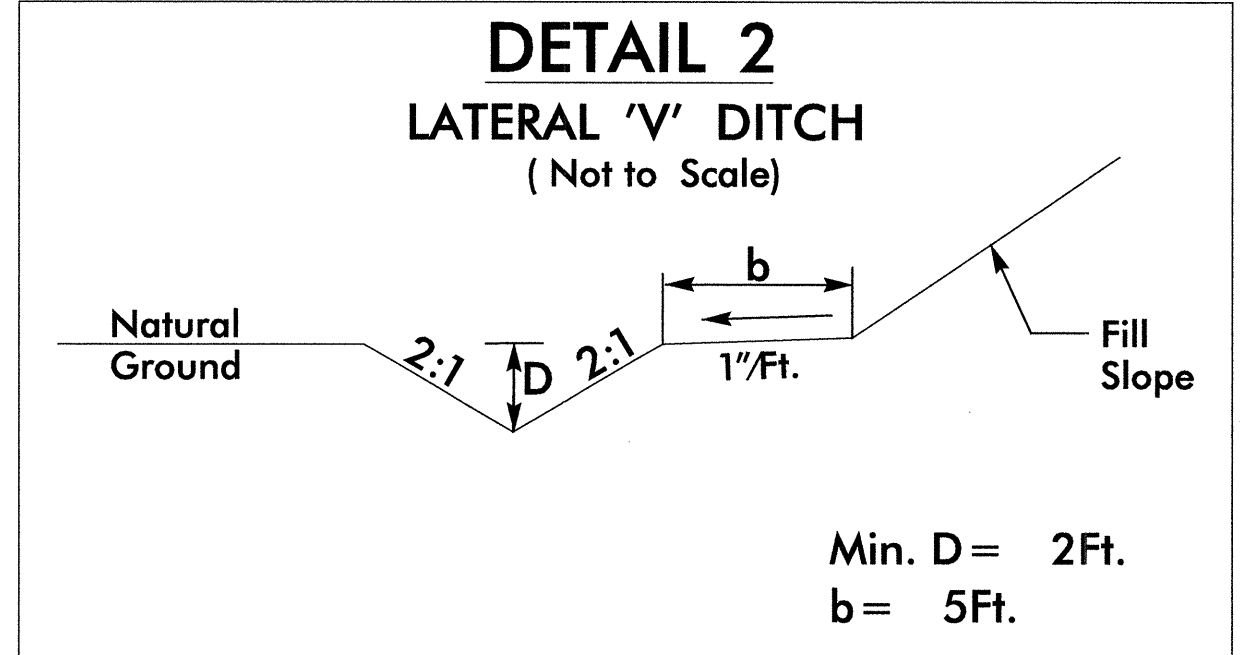
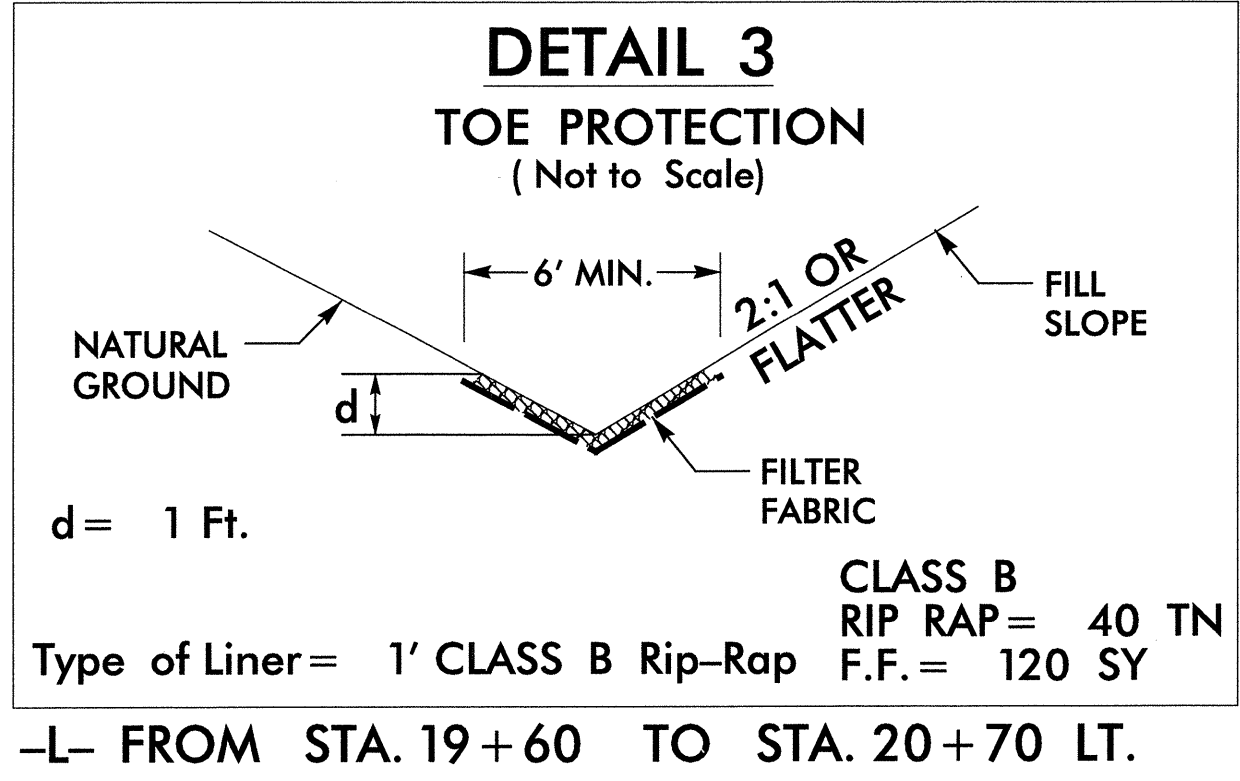

-L- FROM STA. 17+00 LT TO STA. 19+50 LT

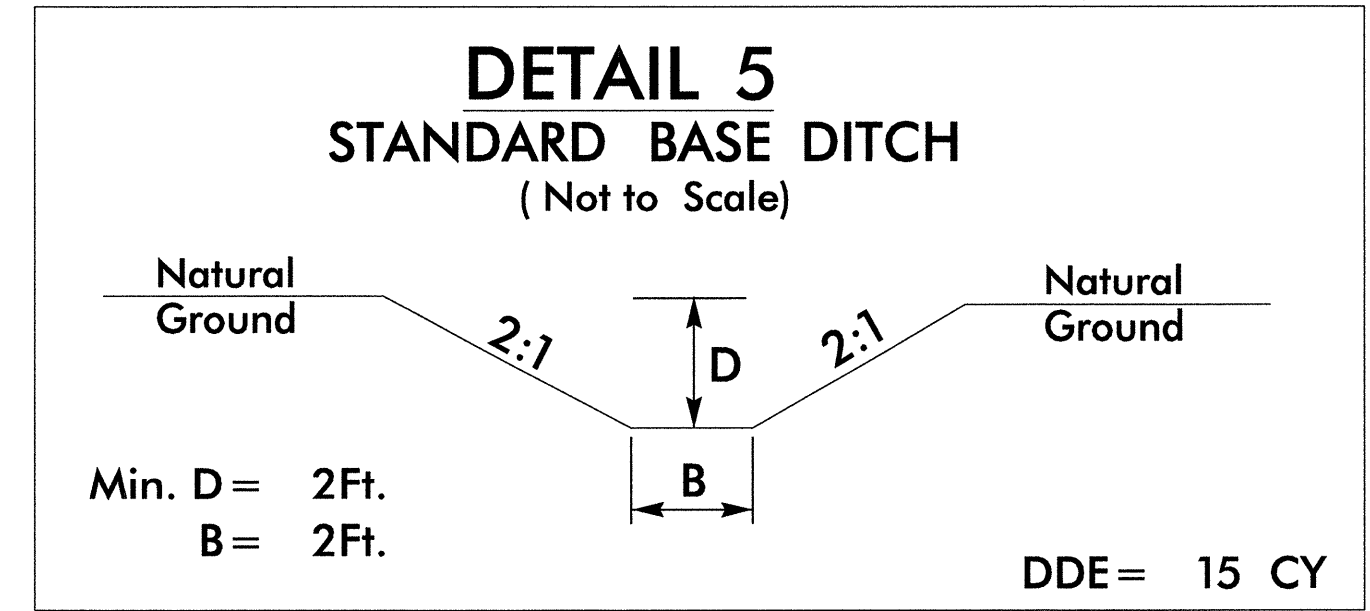

-L- FROM STA. 18+07 RT TO STA. 18+43 RT

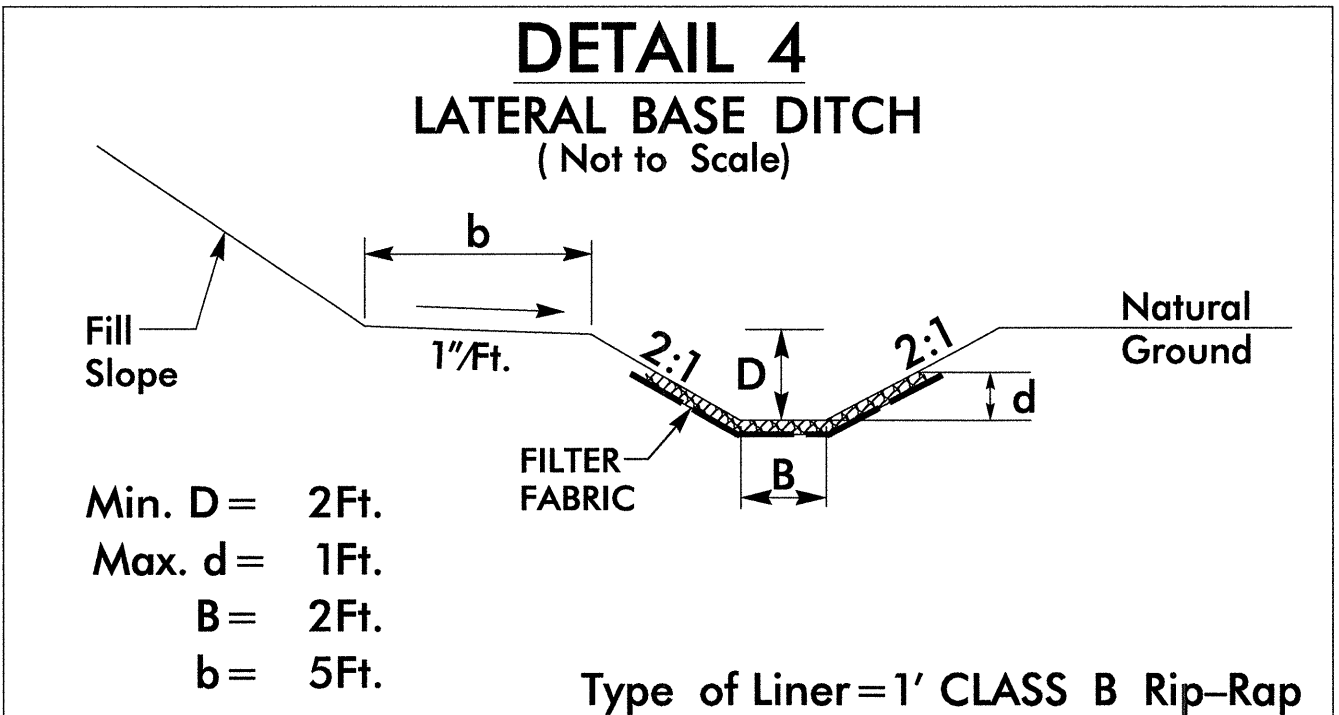

-L- FROM STA. 22+00 RT TO STA. 24+50 RT
 -L- FROM STA. 26+50 LT TO STA. 29+00 LT
 -L- FROM STA. 26+50 RT TO STA. 28+50 RT

-L- CURVE DATA

PI Sta 22+66.70	PI Sta 24+33.74
$\Delta = 29^{\circ}05'59.6"$ (LT)	$\Delta = 13^{\circ}30'21.0"$ (RT)
$D = 18'11"20.9"$	$D = 7'38"22.0"$
$L = 159.99'$	$L = 176.79'$
$T = 81.76'$	$T = 88.81'$
$R = 315.00'$	$R = 750.00'$
** SE = 0.03 FT/FT	** SE = 0.06 FT/FT
RO = 58.06 OUT	RO = 116.13 IN
** DESIGN EXCEPTION REQUIRED	RO = 117.11 OUT

SEE SHEET 8 FOR PROFILE.
 SEE SHEETS S-1 THRU S-30 FOR STRUCTURE PLANS.

REVISIONS

MATCHLINE -L- 18+00 SEE SHEET 4

MATCHLINE -L- 27+00 SEE SHEET 6

2/27/12
 STINEBAUGH CONSULTANTS
 1000 S. W. 10TH AVE. SUITE 100
 BOCA RATON, FL 33432
 (561) 991-1100
 FAX (561) 991-1101
 WWW.STINEBAUGH.COM

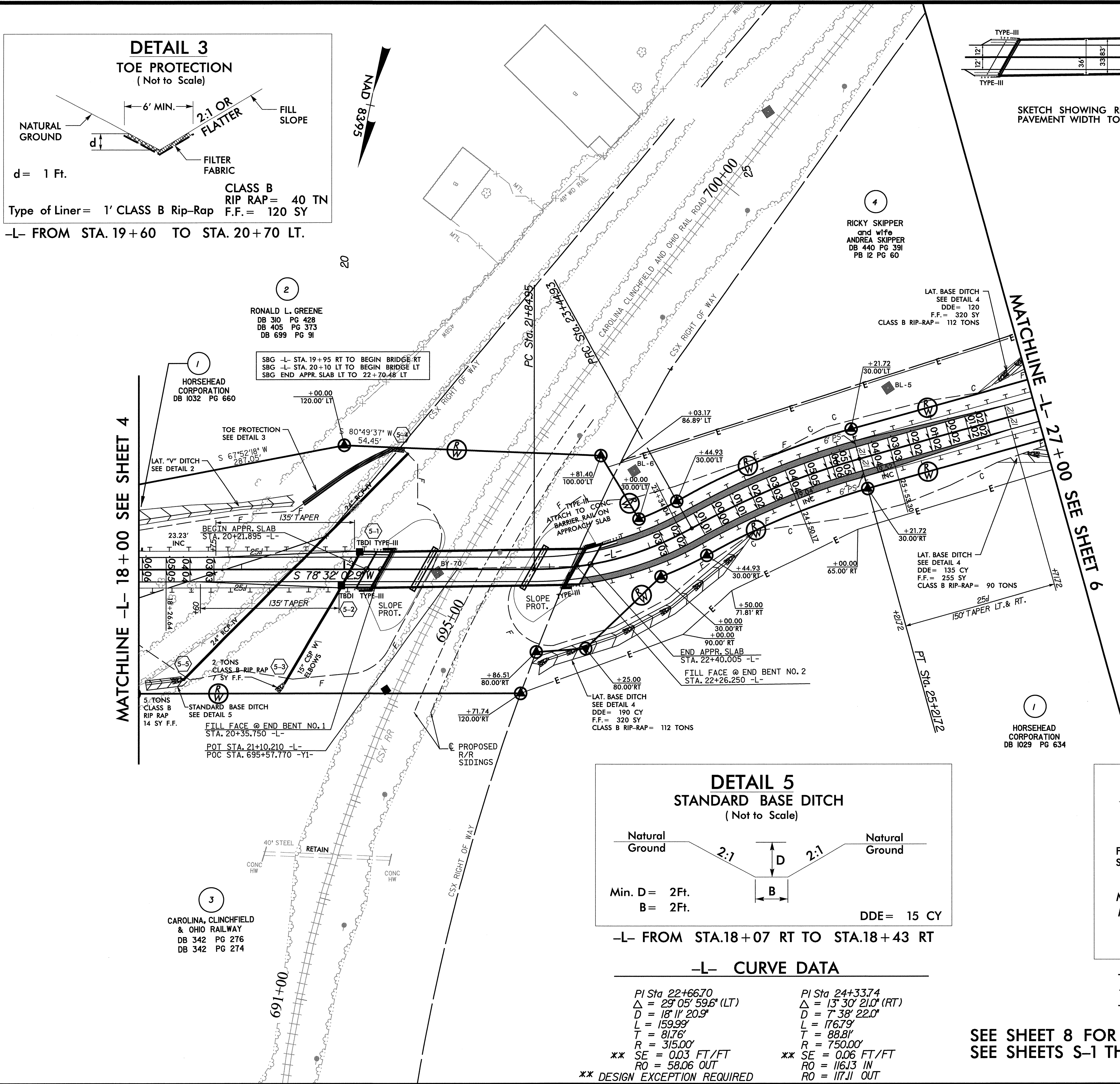

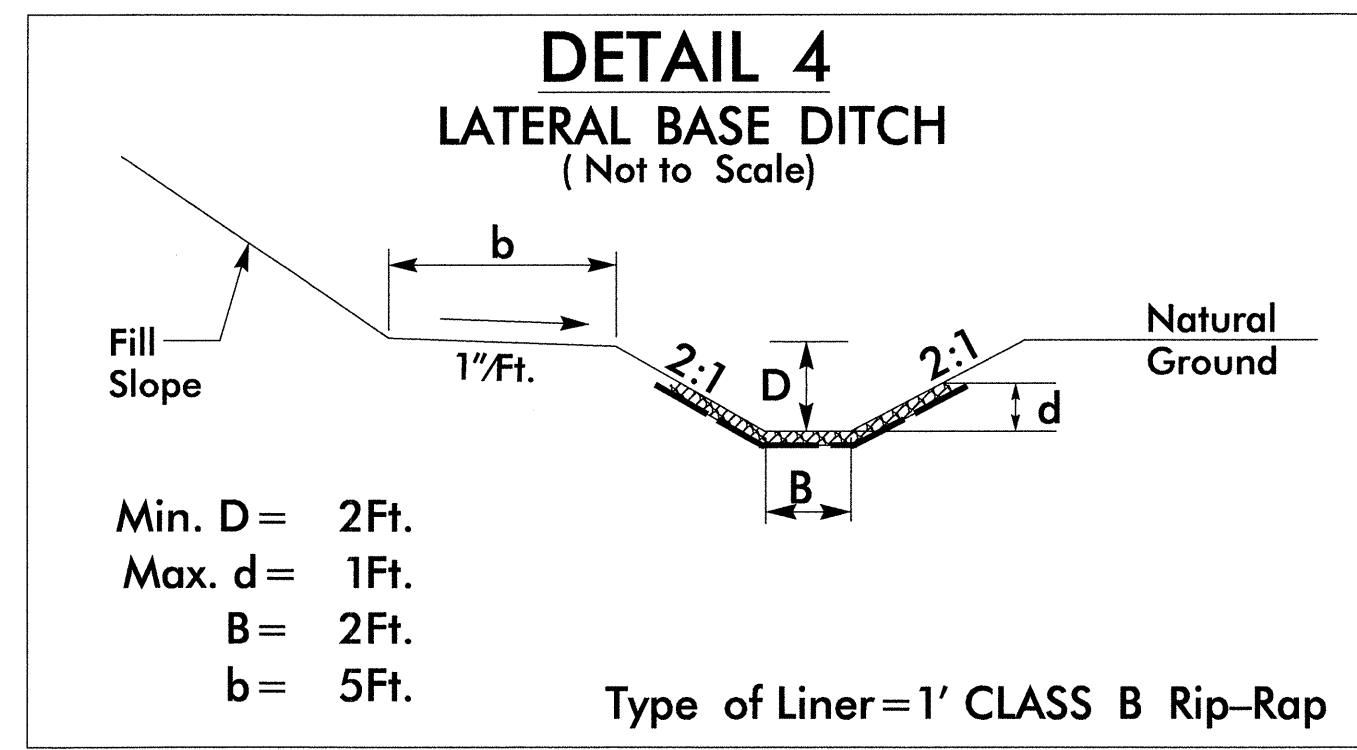

-L- FROM STA.26+50 LT TO STA 29+00 LT
-L- FROM STA.26+50 RT TO STA.28+50 RT

2/27/12
 REVISIONS
 \$\$\$\$SYTIME\$\$\$\$
 \$\$\$\$CEN\$\$\$\$
 \$\$\$\$L\$\$\$\$

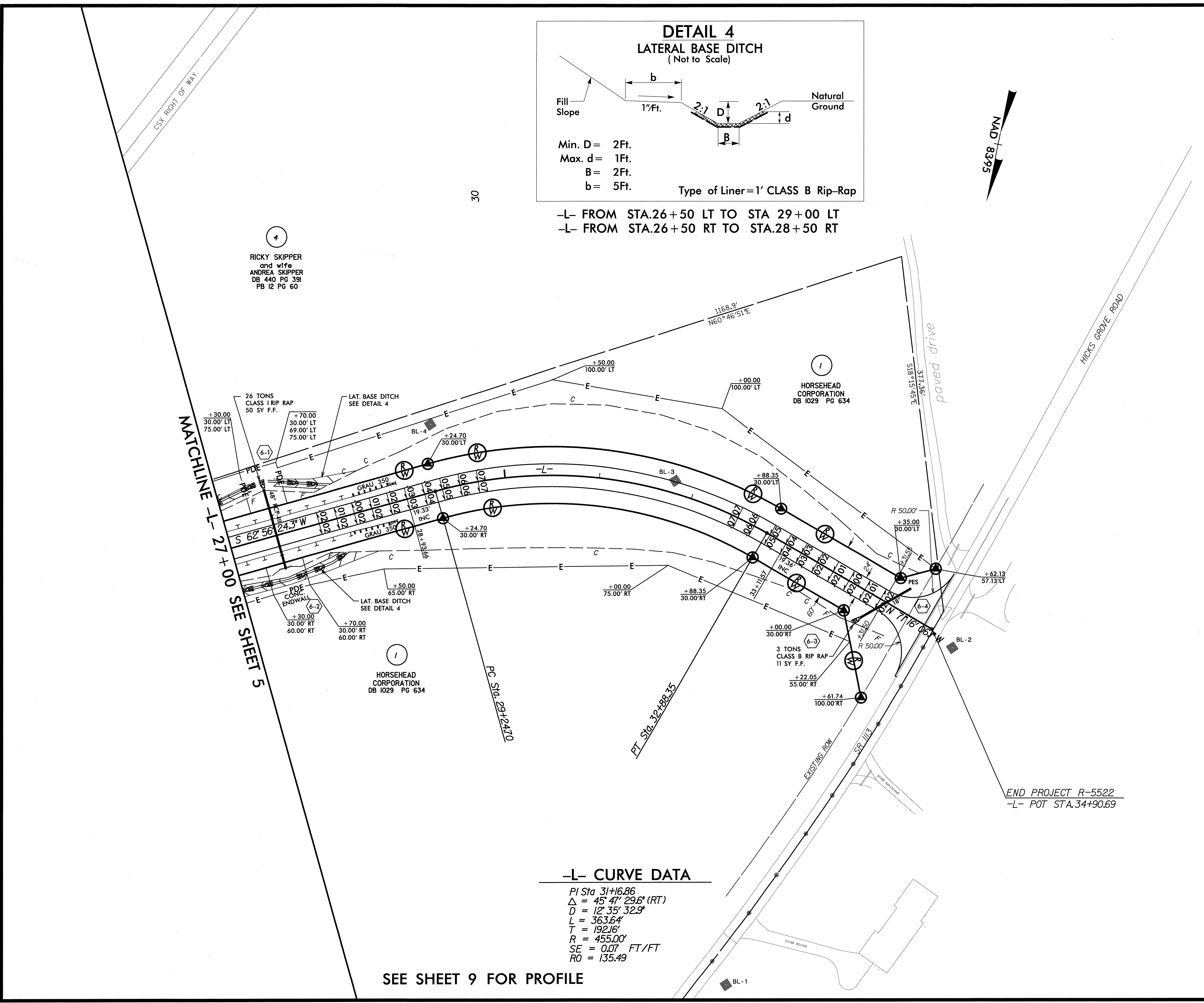

-L- CURVE DATA
 PI Sta 31+16.86
 $\Delta = 45^{\circ} 47' 29.6''$ (RT)
 $D = 12^{\circ} 35' 32.9''$
 $L = 363.64'$
 $T = 192.16'$
 $R = 455.00'$
 $SE = 0.07$ FT/FT
 $RO = 135.49$

SEE SHEET 9 FOR PROFILE

END PROJECT R-5522
-L- POT STA.34+90.69

5/14/99

SYSTEMS ENGINEERING

PROJECT REFERENCE NO. R-5522	SHEET NO. 7
ROADWAY DESIGN ENGINEER	HYDRAULICS ENGINEER

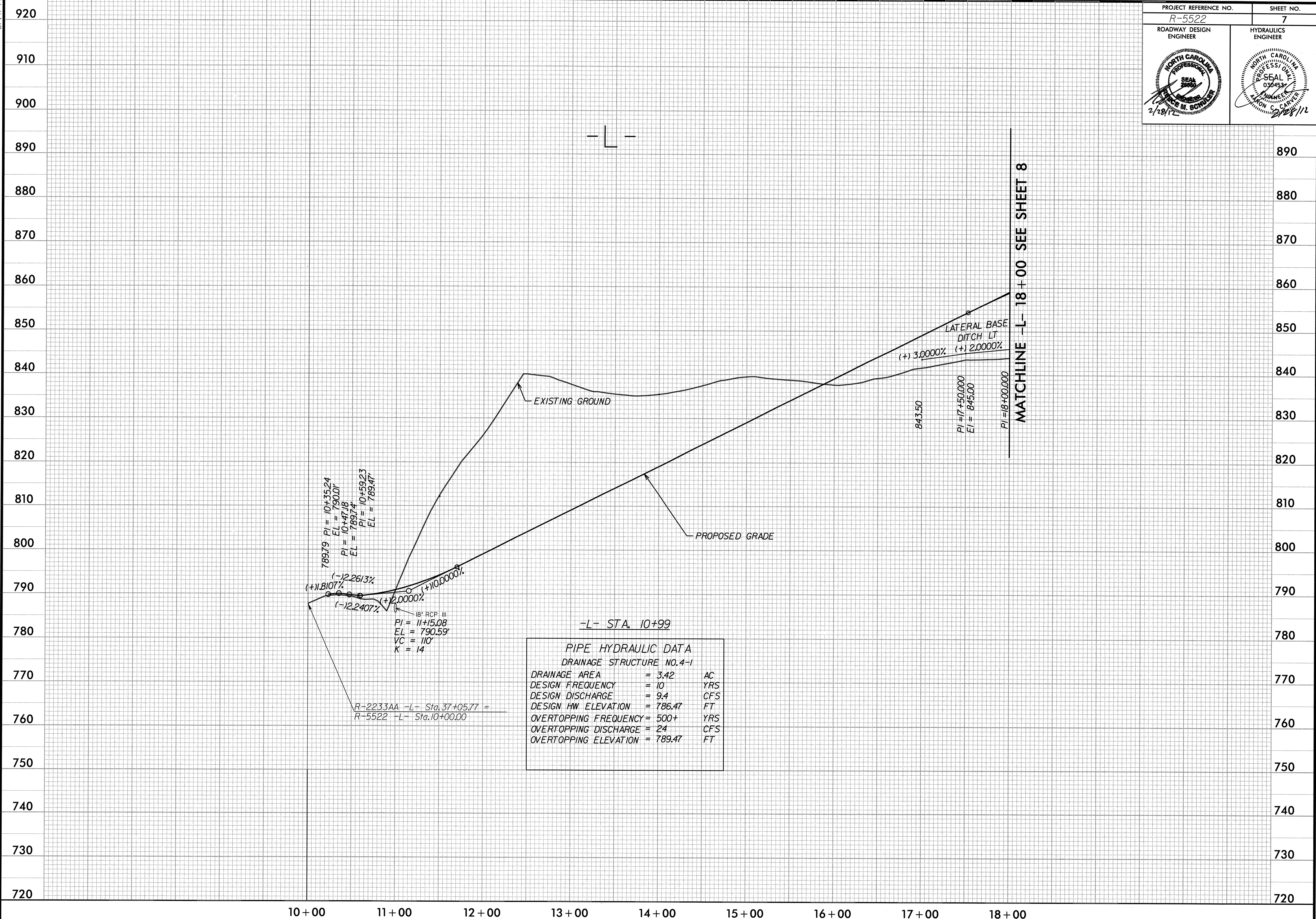

920
910
900
890
880
870
860
850
840
830
820
810
800
790
780
770
760
750
740
730
720

10+00 11+00 12+00 13+00 14+00 15+00 16+00 17+00 18+00

BRIDGE DATA
 C.L. STA. 21+31.00
 1@ 106'6" BOX BEAM GIRDER
 1@ 4'9" CORED SLAB UNIT PRECAST GIRDER
 1@ 42'3" CORED SLAB UNIT PRECAST GIRDER
 SKEW -60° RT. TO LONG CORD
 G.P. ELEV. 877.89 ±

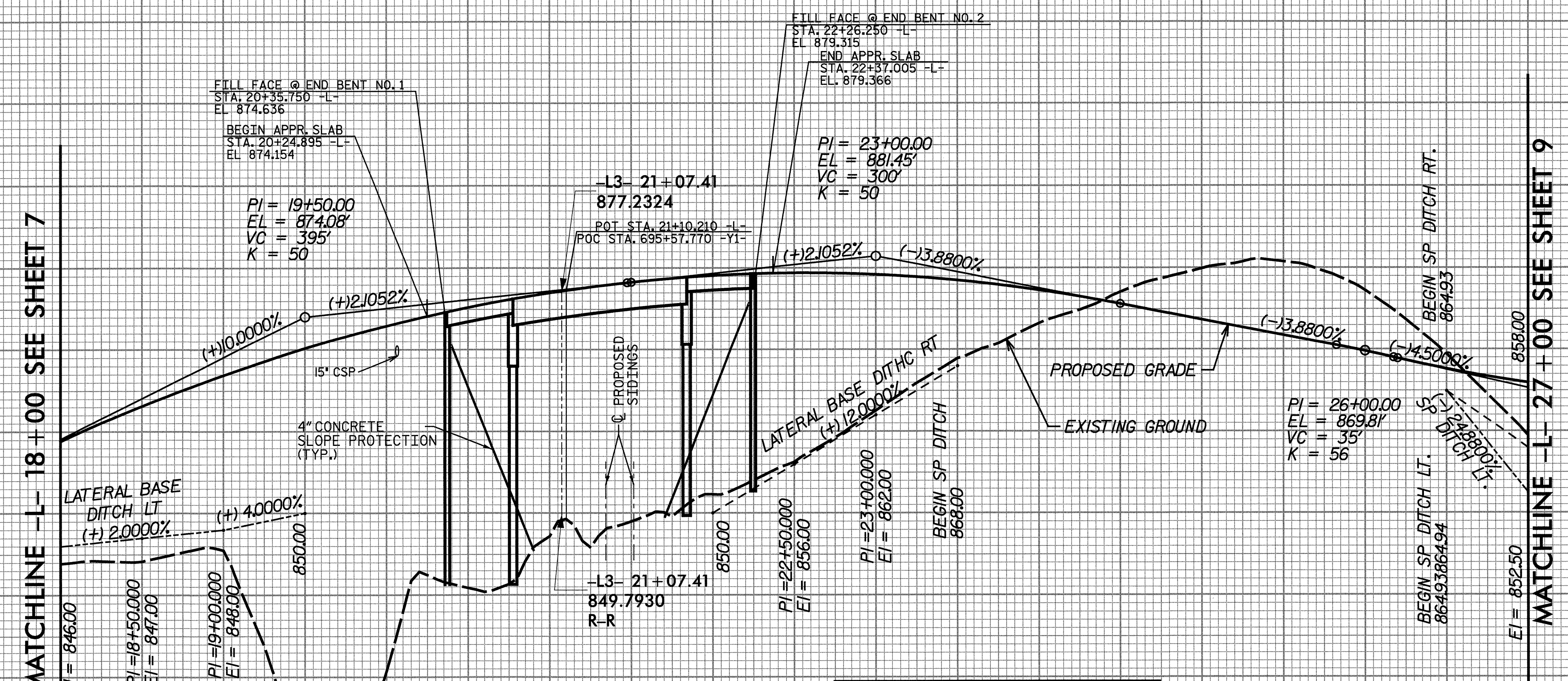

BENCH MARK DATA
 BYTO-
 N 536734.0938 E 1150087.5103
 ELEV. = 846.03'
 -L- STATION 20+90.69 3.00' RT
 P/INC STA. 26+86.35

-L- STA. 19+50

PIPE HYDRAULIC DATA	
DRAINAGE STRUCTURE NO. 5-4,5-5	
DRAINAGE AREA	= 2.64 AC
DESIGN FREQUENCY	= 10 YRS
DESIGN DISCHARGE	= 5.46 CFS
DESIGN HW ELEVATION	= 821.16 FT
100 YEAR DISCHARGE	= 8.00 CFS
100 YEAR HW ELEVATION	= 821.46 FT
OVERTOPPING FREQUENCY	= 500+ YRS
OVERTOPPING DISCHARGE	= 70 CFS
OVERTOPPING ELEVATION	= 838.00 FT

-L- STA. 20+06.5

PIPE HYDRAULIC DATA	
DRAINAGE STRUCTURE NO. 5-1,5-2,5-3	
DRAINAGE AREA	= 0.175 AC
DESIGN FREQUENCY	= 10 YRS
DESIGN DISCHARGE	= 0.36 CFS
DESIGN HW ELEVATION	= 868.25 FT
100 YEAR DISCHARGE	= 0.53 CFS
100 YEAR HW ELEVATION	= 868.44 FT
OVERTOPPING FREQUENCY	= 500+ YRS
OVERTOPPING DISCHARGE	= NA CFS
OVERTOPPING ELEVATION	= 849.79 FT

5/14/99
 SYSTEMS
 DOWNS

5/14/99

PROJECT REFERENCE NO. R-5522	SHEET NO. 9
ROADWAY DESIGN ENGINEER	HYDRAULICS ENGINEER

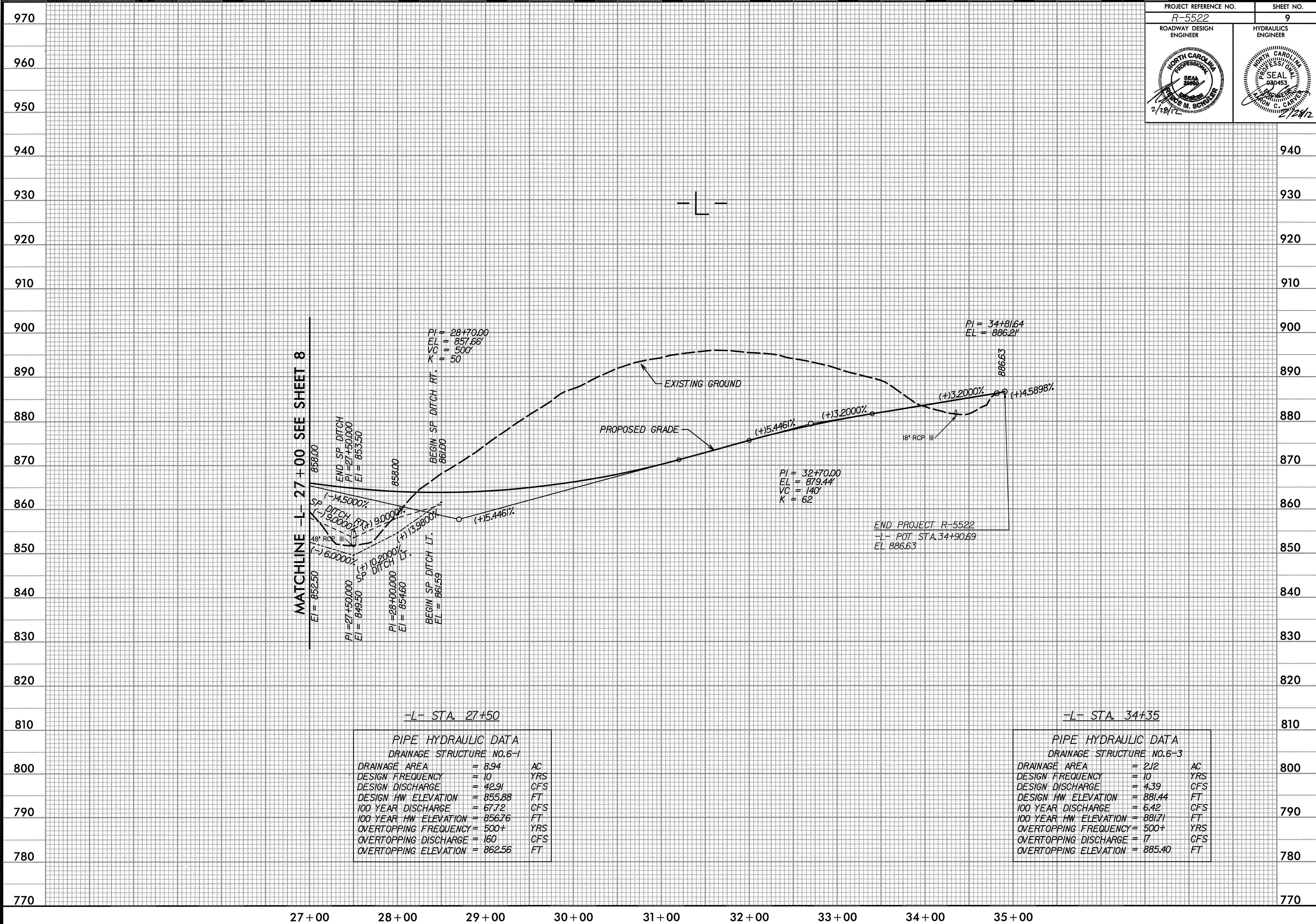

MATCHLINE -L- 27+00 SEE SHEET 8

-L- STA. 27+50

PIPE HYDRAULIC DATA		
DRAINAGE STRUCTURE NO.6-1		
DRAINAGE AREA	= 8.94	AC
DESIGN FREQUENCY	= 10	YRS
DESIGN DISCHARGE	= 42.91	CFS
DESIGN HW ELEVATION	= 855.88	FT
100 YEAR DISCHARGE	= 67.72	CFS
100 YEAR HW ELEVATION	= 856.76	FT
OVERTOPPING FREQUENCY	= 500+	YRS
OVERTOPPING DISCHARGE	= 160	CFS
OVERTOPPING ELEVATION	= 862.56	FT

-L- STA. 34+35

PIPE HYDRAULIC DATA		
DRAINAGE STRUCTURE NO.6-3		
DRAINAGE AREA	= 2.12	AC
DESIGN FREQUENCY	= 10	YRS
DESIGN DISCHARGE	= 4.39	CFS
DESIGN HW ELEVATION	= 881.44	FT
100 YEAR DISCHARGE	= 6.42	CFS
100 YEAR HW ELEVATION	= 881.71	FT
OVERTOPPING FREQUENCY	= 500+	YRS
OVERTOPPING DISCHARGE	= 17	CFS
OVERTOPPING ELEVATION	= 885.40	FT

5/14/99