

See Sheet 1-A For Index of Sheets
 See sheet 1-B For Symbology Sheet
 See sheet 1-C For Survey Control Sheet

STATE OF NORTH CAROLINA
 DIVISION OF HIGHWAYS

HARNETT COUNTY

**LOCATION: BRIDGE NO. 40 OVER BARBEQUE CREEK
 ON SR 1213 (BUIE ROAD)**

TYPE OF WORK: GRADING, DRAINAGE, PAVING AND STRUCTURE

STATE	STATE PROJECT REFERENCE NO.	SHEET NO.	TOTAL SHEETS
N.C.	B-4542	1	
STATE PROJ. NO.	F. A. PROJ. NO.	DESCRIPTION	
33757.1.1	BRSTP-1213(7)	PE	
33757.2.1	BRSTP-1213(7)	R/W	
33757.3.1	BRSTP-1213(7)	CONST	

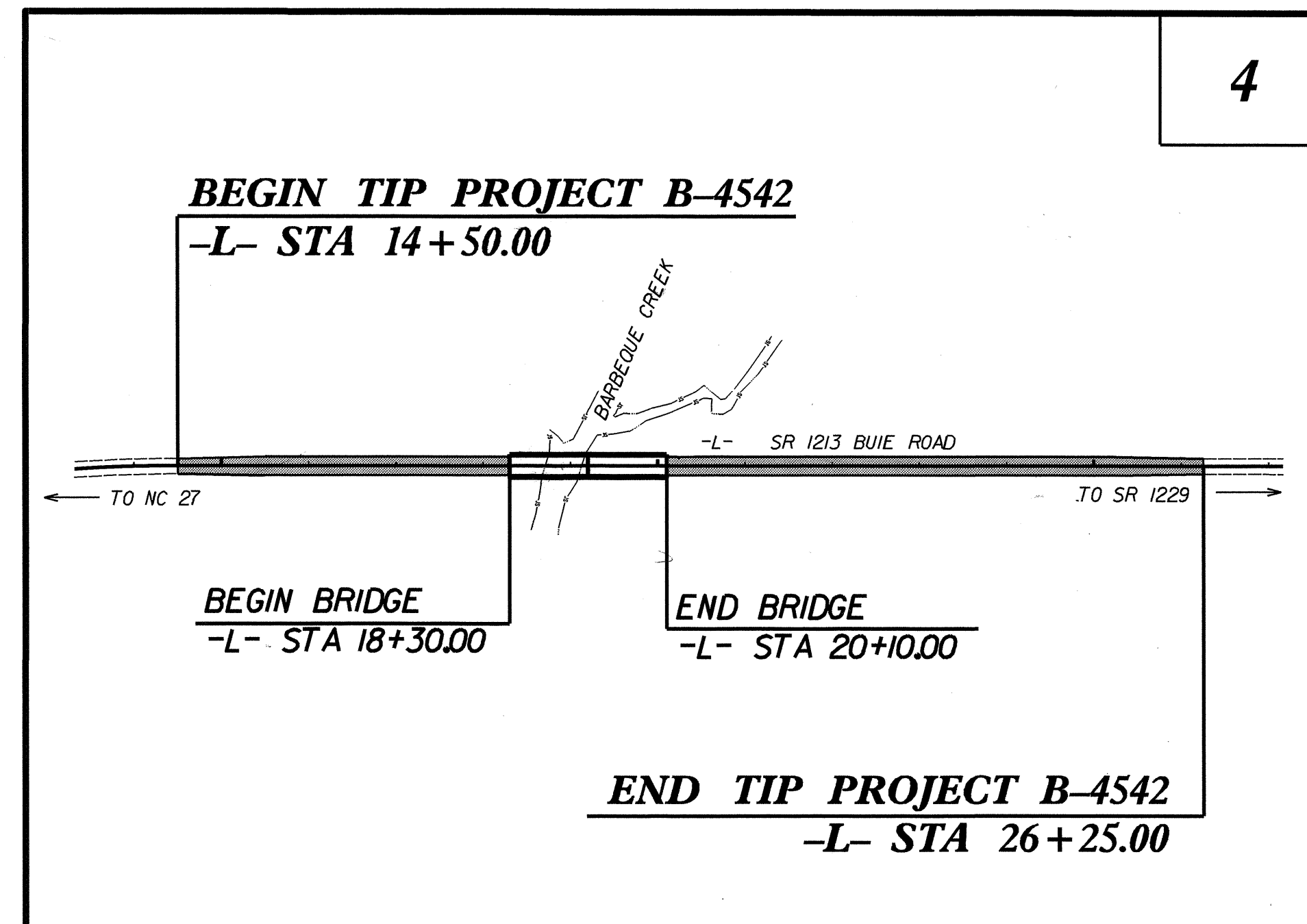
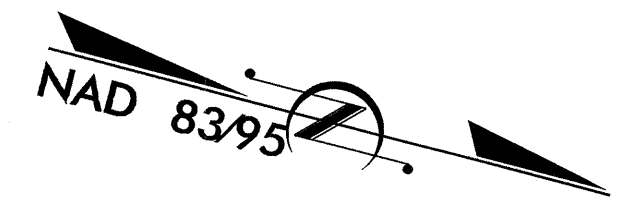
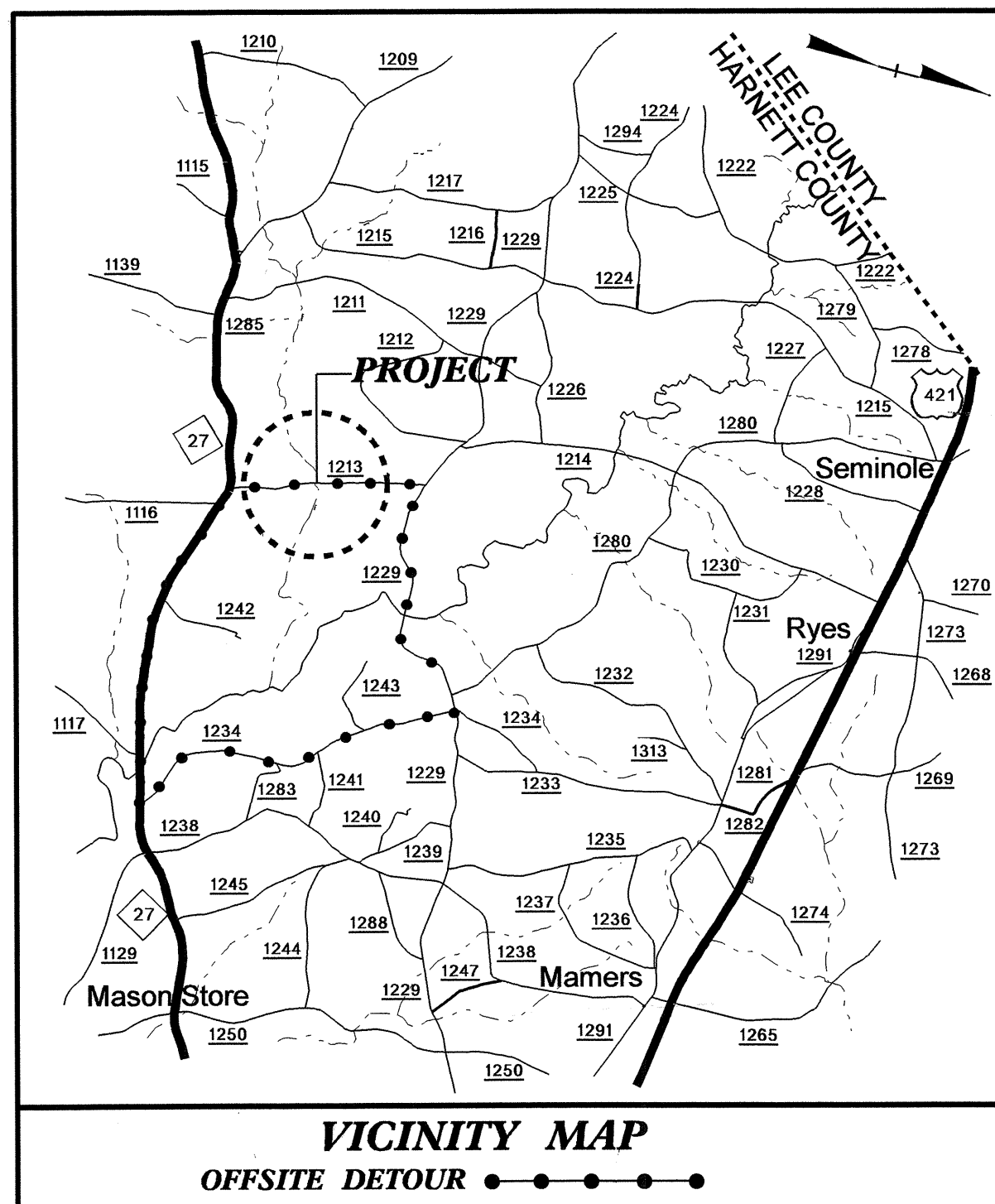

TIP PROJECT: B-4542

CONTRACT: C202732

GRAPHIC SCALES

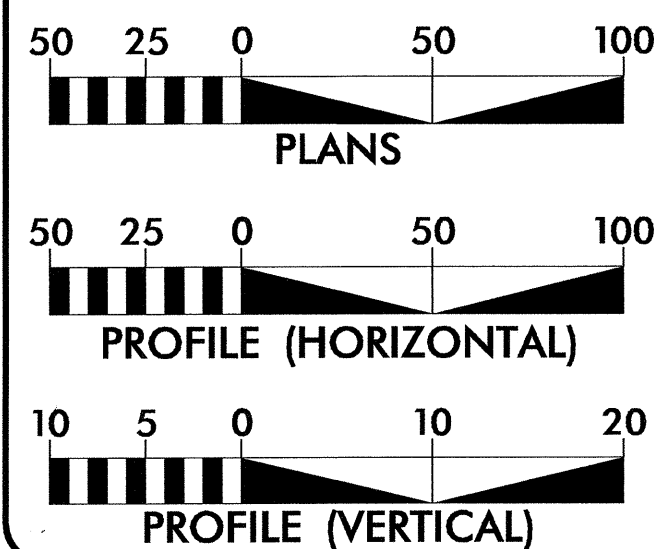

DESIGN DATA

ADT 2011 = 1037
 ADT 2031 = 1630
 DHV = 10 %
 D = 60 %
 T = 3 % *
 V = 60 MPH
 MINOR COLLECTOR
 * TTST 1% DUAL 2%
 SUB-REGIONAL TIER

PROJECT LENGTH

LENGTH ROADWAY TIP PROJECT B-4542 = 0.189 MILES
 LENGTH STRUCTURE TIP PROJECT B-4542 = 0.034 MILES
 TOTAL LENGTH OF TIP PROJECT B-4542 = 0.223 MILES

Prepared In the Office of:
DIVISION OF HIGHWAYS
 1000 Birch Ridge Dr., Raleigh NC, 27610

2006 STANDARD SPECIFICATIONS
 RIGHT OF WAY DATE:
 MARCH 19, 2010
 LETTING DATE:
 MARCH 20, 2012

GARY LOVERING, PE
 PROJECT ENGINEER
ANTHONY WEST
 PROJECT DESIGN ENGINEER

HYDRAULICS ENGINEER

[Signature]
 SIGNATURE:
ROADWAY DESIGN ENGINEER
[Signature]
 SIGNATURE:

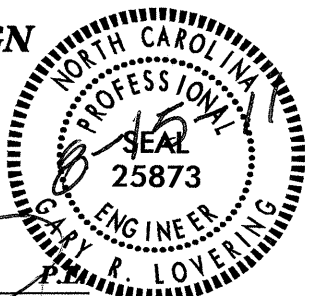

**DIVISION OF HIGHWAYS
 STATE OF NORTH CAROLINA**

[Signature]
Art McMiller
 STATE HIGHWAY DESIGN ENGINEER

26-JUL-2011 09:14 R:\Roadway\Proj\B4542_Rdy_Tsh.dgn \$\$\$USERNAME\$\$\$

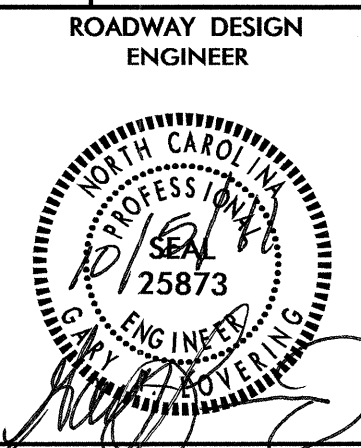

SHEET NUMBER	SHEET
1	TITLE SHEET
1-A	INDEX OF SHEETS, GENERAL NOTES, AND LIST OF STANDARD DRAWINGS
1-B	CONVENTIONAL SYMBOLS
1-C	SURVEY CONTROL SHEET
2	PAVEMENT SCHEDULE, TYPICAL SECTIONS, AND WEDGING DETAIL
2-A TO 2-B	DETAIL FOR METHOD OF PIPE INSTALLATION - METHOD A
2-C	DETAIL OF ANCHORAGE FOR FRAMES
2-D	DETAIL OF SUB REGIONAL BRIDGE APPROACH FILL
3	SUMMARY OF QUANTITIES
3-A	SUMMARY OF PAVEMENT REMOVAL, SUMMARY OF PAVEMENT BREAKUP, SUMMARY OF SHOULDER BERM GUTTER, SUMMARY OF EARTHWORK AND GUARDRAIL SUMMARY
3-B	DRAINAGE SUMMARY
4	PLAN SHEET
5	PROFILE SHEET
TMP-1 THRU TMP-2	TRAFFIC CONTROL PLANS
SD-1	SIGN DESIGN PLANS
PMP-1 THRU PMP-2	PAVEMENT MARKING PLANS
EC-1 THRU EC-5	EROSION CONTROL PLANS
X-0	CROSS SECTION SUMMARY SHEET
X-1 THRU X-6	CROSS-SECTIONS
S-1 THRU S-22	STRUCTURE PLANS

GENERAL NOTES:

2006 SPECIFICATIONS
EFFECTIVE: 07-18-06
REVISED: 07-30-08

GRADING AND SURFACING OR RESURFACING AND WIDENING:

THE GRADE LINES SHOWN DENOTE THE FINISHED ELEVATION OF THE PROPOSED SURFACING AT GRADE POINTS SHOWN ON THE TYPICAL SECTIONS. WHERE NO GRADE LINES ARE SHOWN, THE PROFILES SHOWN DENOTE THE TOP ELEVATION OF THE EXISTING PAVEMENT ALONG THE CENTER LINE OF SURVEY ON WHICH THE PROPOSED RESURFACING WILL BE PLACED. GRADE LINES MAY BE ADJUSTED BY THE ENGINEER IN ORDER TO SECURE A PROPER TIE-IN.

CLEARING:

CLEARING ON THIS PROJECT SHALL BE PERFORMED TO THE LIMITS ESTABLISHED BY METHOD 111.

SUPERELEVATION:

ALL CURVES ON THIS PROJECT SHALL BE SUPERELEVATED IN ACCORDANCE WITH STD. NO. 225.04 USING THE RATE OF SUPERELEVATION AND RUNOFF SHOWN ON THE PLANS. SUPERELEVATION IS TO BE REVOLVED ABOUT THE GRADE POINTS SHOWN ON THE TYPICAL SECTIONS.

SHOULDER CONSTRUCTION:

ASPHALT, EARTH, AND CONCRETE SHOULDER CONSTRUCTION ON THE HIGH SIDE OF SUPERELEVATED CURVES SHALL BE IN ACCORDANCE WITH STD. NO. 560.01.

SIDE ROADS:

THE CONTRACTOR WILL BE REQUIRED TO DO ALL NECESSARY WORK TO PROVIDE SUITABLE CONNECTIONS WITH ALL ROADS, STREETS, AND DRIVES ENTERING THIS PROJECT. THIS WORK WILL BE PAID FOR AT THE CONTRACT UNIT PRICE FOR THE PARTICULAR ITEMS INVOLVED.

UNDERDRAINS:

UNDERDRAINS SHALL BE CONSTRUCTED IN ACCORDANCE WITH STD. NO. 815.03 AT LOCATIONS DIRECTED BY THE ENGINEER.

GUARDRAIL:

THE GUARDRAIL LOCATIONS SHOWN ON THE PLANS MAY BE ADJUSTED DURING CONSTRUCTION AS DIRECTED BY THE ENGINEER. THE CONTRACTOR SHOULD CONSULT WITH THE ENGINEER PRIOR TO ORDERING GUARDRAIL MATERIAL.

TEMPORARY SHORING:

SHORING REQUIRED FOR THE MAINTENANCE OF TRAFFIC WILL BE PAID FOR AS "EXTRA WORK" IN ACCORDANCE WITH SECTION 104-7.

SUBSURFACE PLANS:

NO SUBSURFACE PLANS ARE AVAILABLE ON THIS PROJECT. THE CONTRACTOR SHOULD MAKE HIS OWN INVESTIGATION AS TO THE SUBSURFACE CONDITIONS.

END BENTS:

THE ENGINEER SHALL CHECK THE STRUCTURE END BENT PLANS, DETAILS, AND CROSS-SECTION PRIOR TO SETTING OF THE SLOPE STAKES FOR THE EMBANKMENT OR EXCAVATION APPROACHING A BRIDGE.

RIGHT-OF-WAY MARKERS:

ALL RIGHT-OF-WAY MARKERS ON THIS PROJECT SHALL BE PLACED BY OTHERS.

2006 ROADWAY ENGLISH STANDARD DRAWINGS

The following Roadway Standards as appear in "Roadway Standard Drawings" Highway Design Branch - N. C. Department of Transportation - Raleigh, N. C., Dated July 18, 2006 are applicable to this project and by reference hereby are considered a part of these plans:

STD.NO.	TITLE
DIVISION 2 - EARTHWORK	
200.03	Method of Clearing - Method III
225.02	Guide for Grading Subgrade - Secondary and Local
225.04	Method of Obtaining Superelevation - Two Lane Pavement
DIVISION 5 - SUBGRADE, BASES AND SHOULDERS	
560.01	Method of Shoulder Construction - High Side of Superelevated Curve - Method 1
DIVISION 8 - INCIDENTALS	
815.03	Pipe Underdrain and Blind Drain
840.00	Concrete Base Pad for Drainage Structures
840.29	Frames and Narrow Slot Flat Grates
840.35	Traffic Bearing Grated Drop Inlet - for Cast Iron Double Frame and Grates
840.46	Traffic Bearing Precast Drainage Structure
840.66	Drainage Structure Steps
846.01	Concrete Curb, Gutter and Curb & Gutter
846.04	Drop Inlet Installation in Shoulder Berm Gutter
862.01	Guardrail Placement
862.02	Guardrail Installation
862.03	Structure Anchor Units















EFF. 07-18-06
REV. 01-02-07

Note: Not to Scale











*S.U.E. = Subsurface Utility Engineering

CONVENTIONAL PLAN SHEET SYMBOLS











BOUNDARIES AND PROPERTY:

State Line	-----
County Line	-----
Township Line	-----
City Line	-----
Reservation Line	-----
Property Line	-----
Existing Iron Pin	----- 
Property Corner	----- 
Property Monument	----- 
Parcel/Sequence Number	----- 
Existing Fence Line	----- 
Proposed Woven Wire Fence	----- 
Proposed Chain Link Fence	----- 
Proposed Barbed Wire Fence	----- 
Existing Wetland Boundary	----- 
Proposed Wetland Boundary	----- 
Existing Endangered Animal Boundary	----- 
Existing Endangered Plant Boundary	----- 
Known Soil Contamination: Boundary or Site	----- 
Potential Soil Contamination: Boundary or Site	----- 





BUILDINGS AND OTHER CULTURE:

Gas Pump Vent or U/G Tank Cap	----- 
Sign	----- 
Well	----- 
Small Mine	----- 
Foundation	----- 
Area Outline	----- 
Cemetery	----- 
Building	----- 
School	----- 
Church	----- 
Dam	----- 



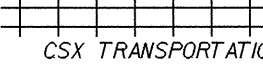

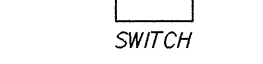
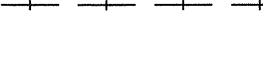

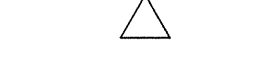

HYDROLOGY:

Stream or Body of Water	-----
Hydro, Pool or Reservoir	----- 
Jurisdictional Stream	----- 
Buffer Zone 1	----- 
Buffer Zone 2	----- 
Flow Arrow	----- 
Disappearing Stream	----- 
Spring	----- 
Wetland	----- 
Proposed Lateral, Tail, Head Ditch	----- 
False Sump	----- 



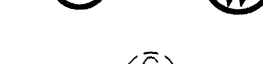
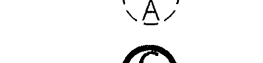
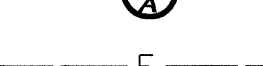
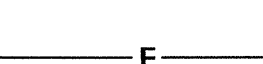

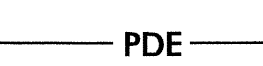
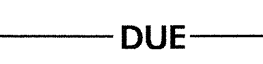
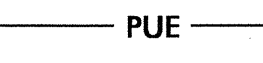
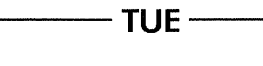
RAILROADS:

Standard Gauge	----- 
RR Signal Milepost	----- 
Switch	----- 
RR Abandoned	----- 
RR Dismantled	----- 



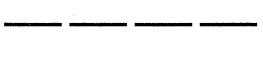
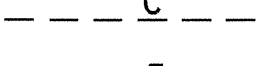
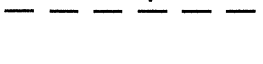
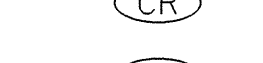
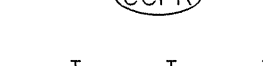
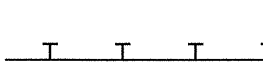
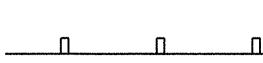
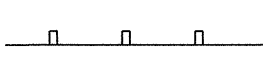

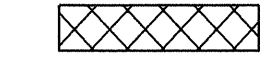
RIGHT OF WAY:

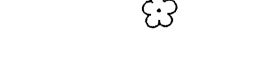
Baseline Control Point	----- 
Existing Right of Way Marker	----- 
Existing Right of Way Line	----- 
Proposed Right of Way Line	----- 
Proposed Right of Way Line with Iron Pin and Cap Marker	----- 
Proposed Right of Way Line with Concrete or Granite Marker	----- 
Existing Control of Access	----- 
Proposed Control of Access	----- 
Existing Easement Line	----- 
Proposed Temporary Construction Easement	----- 
Proposed Temporary Drainage Easement	----- 
Proposed Permanent Drainage Easement	----- 
Proposed Permanent Drainage / Utility Easement	----- 
Proposed Permanent Utility Easement	----- 
Proposed Temporary Utility Easement	----- 
Proposed Aerial Utility Easement	----- 

ROADS AND RELATED FEATURES:





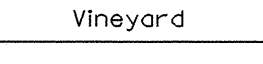

Proposed Permanent Easement with Iron Pin and Cap Marker	----- 
Existing Edge of Pavement	----- 
Existing Curb	----- 
Proposed Slope Stakes Cut	----- 
Proposed Slope Stakes Fill	----- 
Proposed Curb Ramp	----- 
Curb Cut Future Ramp	----- 
Existing Metal Guardrail	----- 
Proposed Guardrail	----- 
Existing Cable Guiderail	----- 
Proposed Cable Guiderail	----- 
Equality Symbol	----- 
Pavement Removal	----- 

VEGETATION:

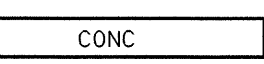

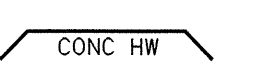
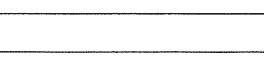

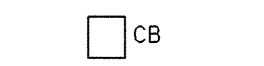

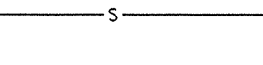

Single Tree	----- 
Single Shrub	----- 
Hedge	----- 
Woods Line	----- 

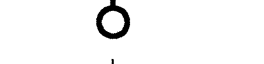
Orchard	----- 
Vineyard	----- 



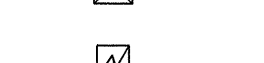

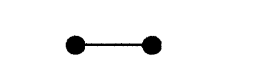
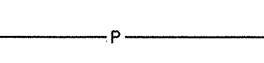
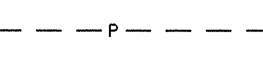
EXISTING STRUCTURES:

MAJOR:	
Bridge, Tunnel or Box Culvert	----- 
Bridge Wing Wall, Head Wall and End Wall	----- 
MINOR:	
Head and End Wall	----- 
Pipe Culvert	----- 
Footbridge	----- 
Drainage Box: Catch Basin, DI or JB	----- 
Paved Ditch Gutter	----- 
Storm Sewer Manhole	----- 
Storm Sewer	----- 





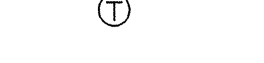
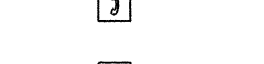
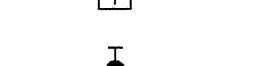
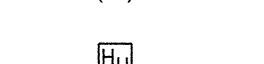
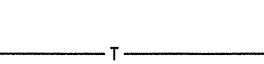
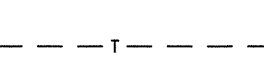
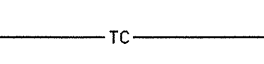
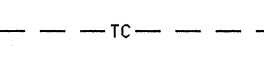
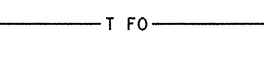
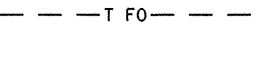

UTILITIES:

POWER:	
Existing Power Pole	----- 
Proposed Power Pole	----- 
Existing Joint Use Pole	----- 
Proposed Joint Use Pole	----- 
Power Manhole	----- 
Power Line Tower	----- 
Power Transformer	----- 
U/G Power Cable Hand Hole	----- 
H-Frame Pole	----- 
Recorded U/G Power Line	----- 
Designated U/G Power Line (S.U.E.*)	----- 





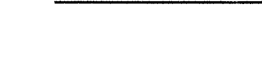

TELEPHONE:

Existing Telephone Pole	----- 
Proposed Telephone Pole	----- 
Telephone Manhole	----- 
Telephone Booth	----- 
Telephone Pedestal	----- 
Telephone Cell Tower	----- 
U/G Telephone Cable Hand Hole	----- 
Recorded U/G Telephone Cable	----- 
Designated U/G Telephone Cable (S.U.E.*)	----- 
Recorded U/G Telephone Conduit	----- 
Designated U/G Telephone Conduit (S.U.E.*)	----- 
Recorded U/G Fiber Optics Cable	----- 
Designated U/G Fiber Optics Cable (S.U.E.*)	----- 



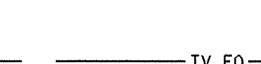
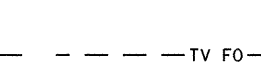

WATER:

Water Manhole	----- 
Water Meter	----- 
Water Valve	----- 
Water Hydrant	----- 
Recorded U/G Water Line	----- 
Designated U/G Water Line (S.U.E.*)	----- 
Above Ground Water Line	----- 



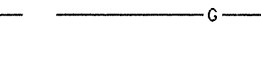

TV:

TV Satellite Dish	----- 
TV Pedestal	----- 
TV Tower	----- 
U/G TV Cable Hand Hole	----- 
Recorded U/G TV Cable	----- 
Designated U/G TV Cable (S.U.E.*)	----- 
Recorded U/G Fiber Optic Cable	----- 
Designated U/G Fiber Optic Cable (S.U.E.*)	----- 





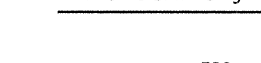





GAS:

Gas Valve	----- 
Gas Meter	----- 
Recorded U/G Gas Line	----- 
Designated U/G Gas Line (S.U.E.*)	----- 
Above Ground Gas Line	----- 

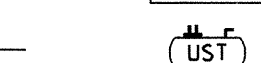
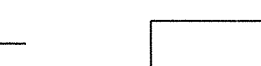
SANITARY SEWER:

Sanitary Sewer Manhole	----- 
Sanitary Sewer Cleanout	----- 
U/G Sanitary Sewer Line	----- 
Above Ground Sanitary Sewer	----- 
Recorded SS Forced Main Line	----- 
Designated SS Forced Main Line (S.U.E.*)	----- 

MISCELLANEOUS:

Utility Pole	----- 
Utility Pole with Base	----- 
Utility Located Object	----- 
Utility Traffic Signal Box	----- 
Utility Unknown U/G Line	----- 
U/G Tank; Water, Gas, Oil	----- 
Underground Storage Tank, Approx. Loc.	----- 
A/G Tank; Water, Gas, Oil	----- 
Geoenvironmental Boring	----- 
U/G Test Hole (S.U.E.*)	----- 
Abandoned According to Utility Records	----- 
End of Information	----- 

6/2/99

PROJECT REFERENCE NO. B-4542	SHEET NO. 2
ROADWAY DESIGN ENGINEER 	PAVEMENT DESIGN ENGINEER

PAVEMENT SCHEDULE	
FINAL PAVEMENT DESIGN	
C1	PROP. APPROX. 2 1/2" ASPHALT CONCRETE SURFACE COURSE, TYPE SF9.5A, AT AN AVERAGE RATE OF 137.5 LBS. PER SQ. YD IN EACH OF TWO LAYERS.
C2	PROP. VAR. DEPTH ASPHALT CONCRETE SURFACE COURSE, TYPE SF9.5A, AT AN AVERAGE RATE OF 110 LBS. PER SQ. YD. PER 1" DEPTH. TO BE PLACED IN LAYERS NOT TO EXCEED 1 1/2" IN DEPTH.
E1	PROP. APPROX. 4" ASPHALT CONCRETE BASE COURSE, TYPE B25.0B, AT AN AVERAGE RATE OF 456 LBS. PER SQ. YD.
E2	PROP. VAR. DEPTH ASPHALT CONCRETE BASE COURSE, TYPE B25.0B, AT AN AVERAGE RATE OF 114 LBS. PER SQ. YD. PER 1" DEPTH. TO BE PLACED IN LAYERS NOT LESS THAN 3" IN DEPTH OR GREATER THAN 5 1/2" IN DEPTH.
T	EARTH MATERIAL.
U	EXISTING PAVEMENT.
W	VARIABLE DEPTH ASPHALT PAVEMENT (SEE STANDARD WEDGING DETAIL)

NOTE: PAVEMENT EDGE SLOPES ARE 1:1 UNLESS SHOWN OTHERWISE.

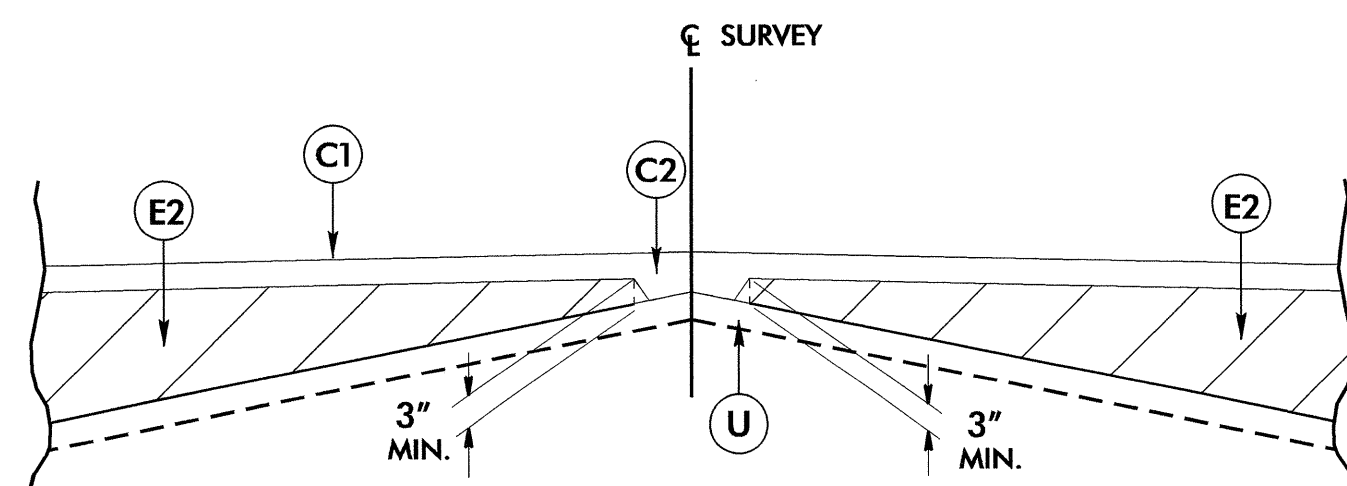
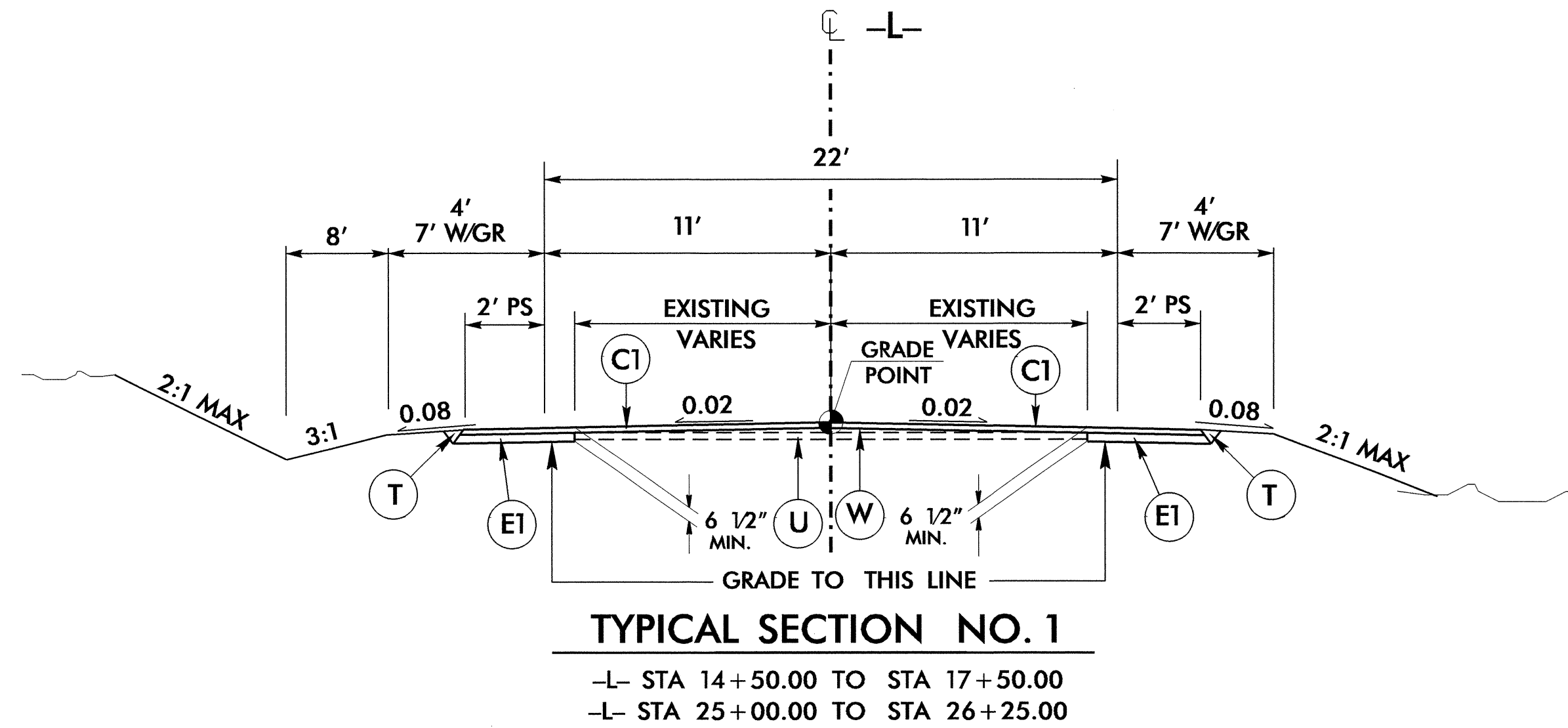

Detail Showing Method of Wedging

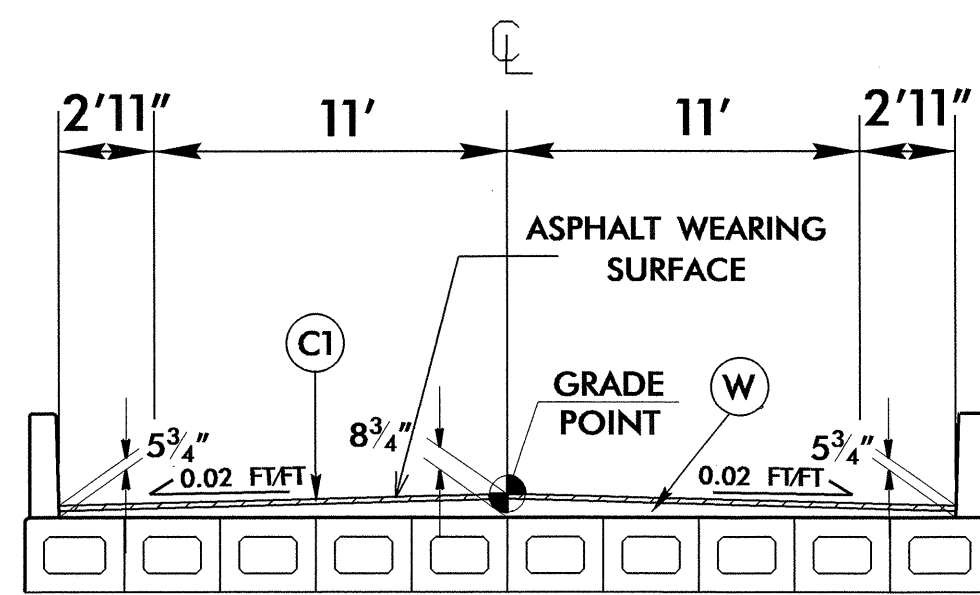
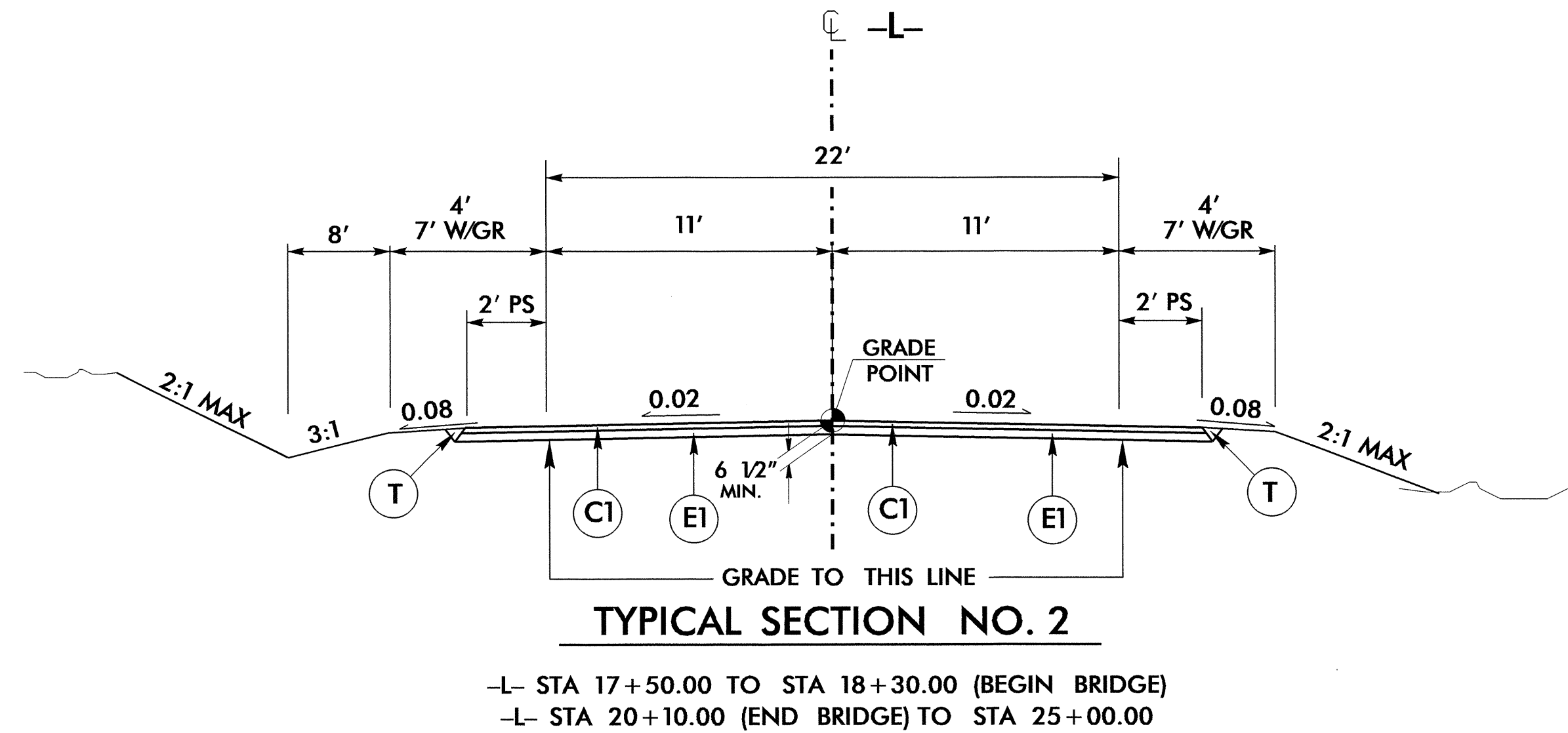

BRIDGE TYPICAL

BRIDGE #40 -L- STA 18+30.00 TO STA 20+10.00

15-AUG-2011 11:55
 P:\Projects\B-4542\B-4542_rdy_tj.p.dgn
 \$\$\$\$SYTIME\$\$\$\$

30-JUL-2009 08:48
 s:\contracts\contract\special details\ericward\stds\06\stds to special details\30001\0300d01.dgn
 Jhowerton AT P5237501

5/14/99

STATE OF NORTH CAROLINA
 DEPT. OF TRANSPORTATION
 DIVISION OF HIGHWAYS
 RALEIGH, N.C.

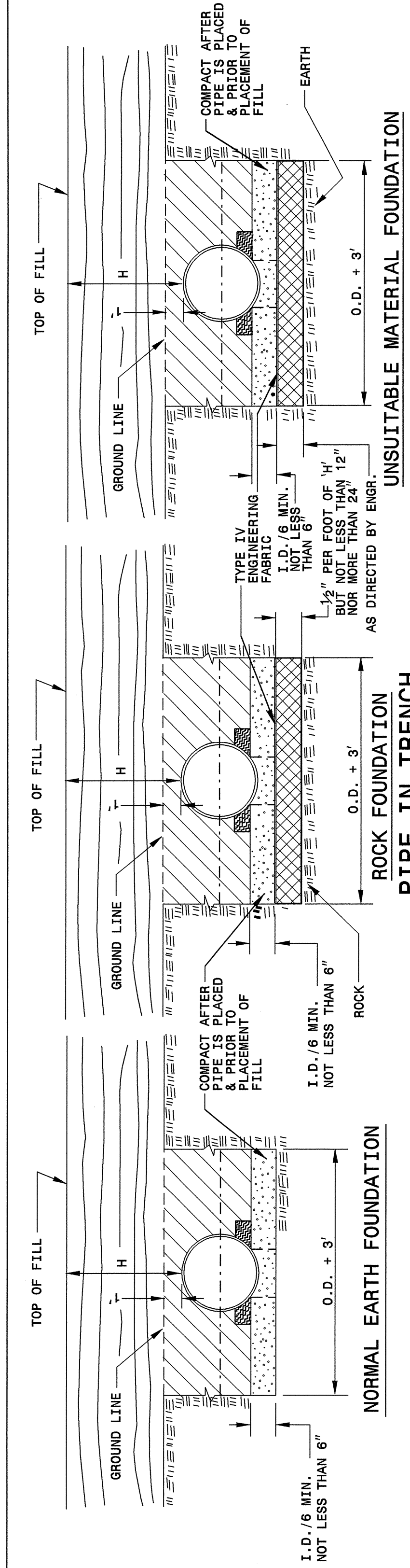

ENGLISH DETAIL DRAWING FOR
METHOD OF PIPE INSTALLATION
 FLEXIBLE PIPE

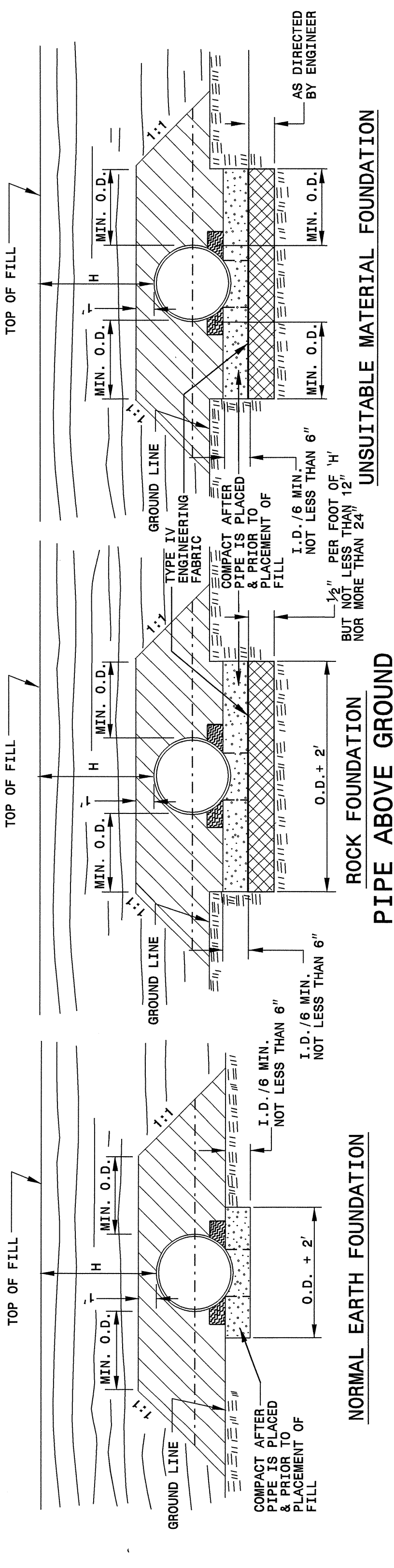

GENERAL NOTES:
 I.D. = THE MAXIMUM HORIZONTAL INSIDE DIAMETER DIMENSION.
 O.D. = THE MAXIMUM HORIZONTAL OUTSIDE DIAMETER DIMENSION.
 H = THE FILL HEIGHT MEASURED VERTICALLY AT ANY POINT ALONG THE PIPE FROM THE TOP OF THE PIPE TO THE TOP OF THE EMBANKMENT AT THAT POINT.
 TAKE CARE TO FULLY COMPACT HAUNCH ZONE OF PIPE BACKFILL.
 LOOSELY PLACED SELECT MATERIAL CLASS III OR CLASS II, TYPE 1 FOR PIPE BEDDING. LEAVE SECTION DIRECTLY BENEATH PIPE UNCOMPACTED AS PIPE SEATING AND BACKFILL WILL ACCOMPLISH COMPACTION.
 DO NOT OPERATE HEAVY EQUIPMENT OVER ANY PIPE CULVERT UNTIL THE PIPE CULVERT HAS BEEN PROPERLY BACKFILLED AND COVERED WITH AT LEAST 3 FEET OF APPROVED MATERIAL.
 SPRINGLINE OF PIPE
 SELECT BACKFILL MATERIAL CLASS III OR CLASS II, TYPE 1 ABOVE AND BELOW SPRINGLINE.
 APPROVED SUITABLE LOCAL MATERIAL.
 UNDISTURBED EARTH MATERIAL
 SELECT MATERIAL CLASS V OR VI FOR FOUNDATION CONDITIONING. ENCAPSULATE WITH ENGINEERING FABRIC AS DIRECTED BY THE ENGINEER.

SHEET 1 OF 3
300D01

STATE OF NORTH CAROLINA
 DEPT. OF TRANSPORTATION
 DIVISION OF HIGHWAYS
 RALEIGH, N.C.

ENGLISH DETAIL DRAWING FOR
METHOD OF PIPE INSTALLATION
 FLEXIBLE PIPE

SHEET 1 OF 3
300D01

STATE OF NORTH CAROLINA
 DEPT. OF TRANSPORTATION
 DIVISION OF HIGHWAYS
 RALEIGH, N.C.

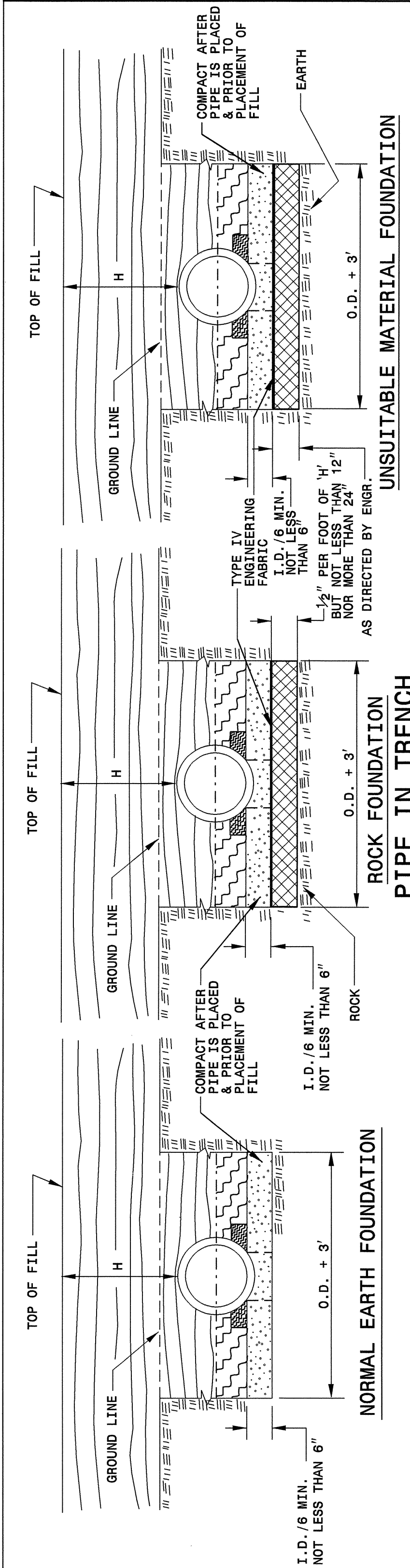

ENGLISH DETAIL DRAWING FOR
METHOD OF PIPE INSTALLATION
 RIGID PIPE

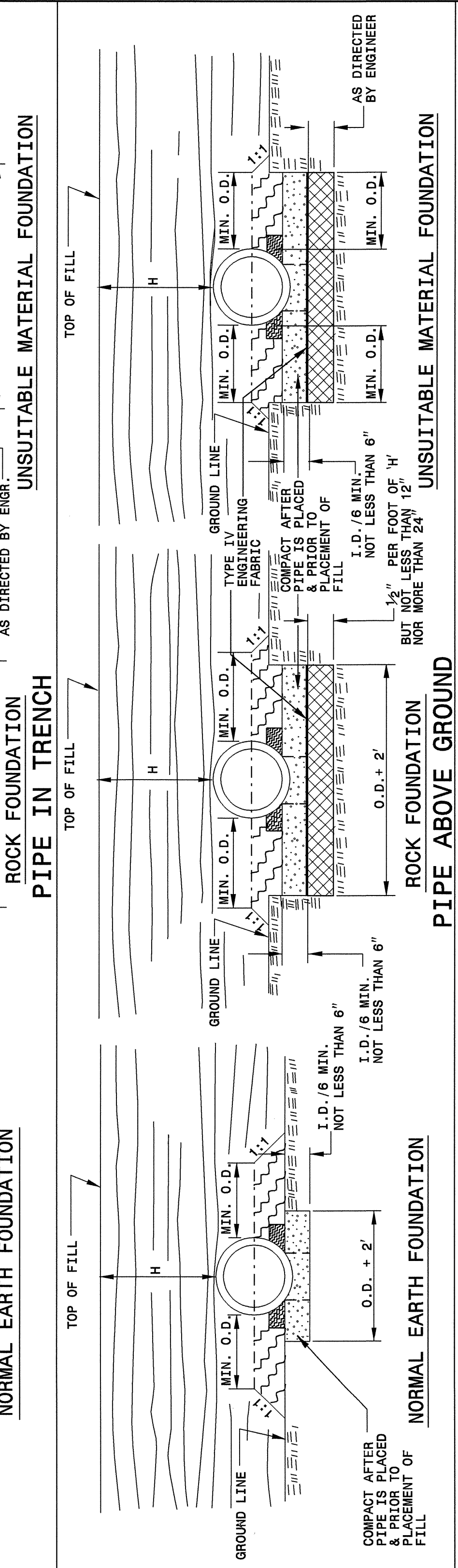

GENERAL NOTES:
 I.D. = THE MAXIMUM HORIZONTAL INSIDE DIAMETER DIMENSION.
 O.D. = THE MAXIMUM HORIZONTAL OUTSIDE DIAMETER DIMENSION.
 H = THE FILL HEIGHT MEASURED VERTICALLY AT ANY POINT ALONG THE PIPE FROM THE TOP OF THE PIPE TO THE TOP OF THE EMBANKMENT AT THAT POINT.
 TAKE CARE TO FULLY COMPACT HAUNCH ZONE OF PIPE BACKFILL.
 LOOSELY PLACED SELECT MATERIAL CLASS III OR CLASS II, TYPE 1 FOR PIPE BEDDING. LEAVE SECTION DIRECTLY BENEATH PIPE UNCOMPACTED AS PIPE SEATING AND BACKFILL WILL ACCOMPLISH COMPACTION.
 DO NOT OPERATE HEAVY EQUIPMENT OVER ANY PIPE CULVERT UNTIL THE PIPE CULVERT HAS BEEN PROPERLY BACKFILLED AND COVERED WITH AT LEAST 3 FEET OF APPROVED MATERIAL.
 SPRINGLINE OF PIPE
 SELECT BACKFILL MATERIAL CLASS III OR CLASS II, TYPE 1 BELOW SPRINGLINE.
 APPROVED SUITABLE LOCAL MATERIAL ABOVE SPRINGLINE.
 UNDISTURBED EARTH MATERIAL
 SELECT MATERIAL CLASS V OR VI FOR FOUNDATION CONDITIONING. ENCAPSULATE WITH ENGINEERING FABRIC AS DIRECTED BY THE ENGINEER.

SHEET 2 OF 3
300D01

STATE OF NORTH CAROLINA
 DEPT. OF TRANSPORTATION
 DIVISION OF HIGHWAYS
 RALEIGH, N.C.

ENGLISH DETAIL DRAWING FOR
METHOD OF PIPE INSTALLATION
 RIGID PIPE

SHEET 2 OF 3
300D01

PROJECT SERVICES UNIT
 STANDARDS AND SPECIAL DESIGN
 Office 919-250-4128 FAX 919-250-4119

SEE PLATE FOR TITLE

ORIGINAL BY: KKempf DATE: 5-15-09
 MODIFIED BY: DATE:
 CHECKED BY: DATE: 7/20/09
 FILE SPEC: /ericward/stds/stdstodetails/30001/0300d01.dgn

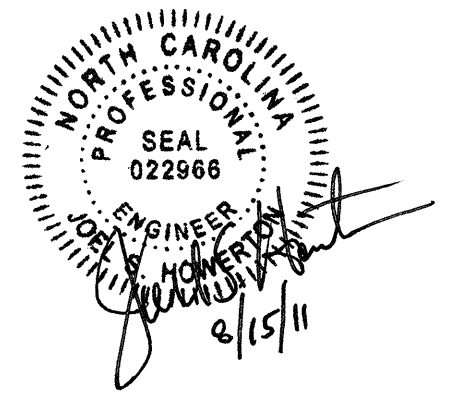

30-Jul-2009 08:49 s:\contracts\contractors\special_details\eroward\stds\06\stds to special_details\30001\0300d01.dgn jhowerton AT PS23750

5/14/99

STATE OF NORTH CAROLINA DEPT. OF TRANSPORTATION DIVISION OF HIGHWAYS RALEIGH, N.C.

ENGLISH DETAIL DRAWING FOR METHOD OF PIPE INSTALLATION FILL HEIGHT TABLES

SHEET 3 OF 3 300D01

STATE OF NORTH CAROLINA DEPT. OF TRANSPORTATION DIVISION OF HIGHWAYS RALEIGH, N.C.

ENGLISH DETAIL DRAWING FOR METHOD OF PIPE INSTALLATION FILL HEIGHT TABLES

SHEET 3 OF 3 300D01

FLEXIBLE PIPE

Round Corrugated Steel Pipe
2 2/3 x 1/2 corrugation **

Diameter (inches)	Minimum cover (inches)	Maximum Height of Cover (feet)				
		16 (Ga)	14	12	10	8
12	12	204	256			
15	12	162	204			
18	12	135	169	239		
21	12	115	145	204		
24	12	100	126	178		
30	12	79	100	142		
36	12	65	83	117	152	
42	12	55	70	100	130	160
48	12	48			113	139
54	12		54	77	100	123
60	12			69	90	111
66	12				81	100
72	12				74	91
78	12					81
84	12					69

Round Corrugated Aluminum Pipe
2 2/3 x 1/2 corrugation **

Diameter (inches)	Minimum cover (inches)	Maximum Height of Cover (feet)				
		16 (Ga)	14	12	10	8
12	12	123	155	218	281	344
15	12	98	123	174	224	275
18	12	81	102	144	187	228
21	12	69	87	123	160	195
24	12	60	76	108	139	171
27	12		67	95	123	151
30	12		60	85	111	136
36	12		50	71	92	113
42	12			60	78	96
48	12			52	68	84
54	12			46	60	74
60	12				50	62
66	12				51	51
72	12				41	41

- HDPE - * (Minimum fill) 2' for pipe diameters ≥ 12" and ≤ 60"
- * (Maximum fill) 20' for pipe diameters ≤ 24"
- 17' for pipe diameters ≥ 30" and ≤ 60"
- PVC - * (Minimum fill) 2' for pipe diameters ≥ 12" and ≤ 36"
- * (Maximum fill) 30' for pipe diameters ≥ 12" and ≤ 36"

* FILL HEIGHT IS MEASURED FROM THE TOP OF THE PIPE TO THE BOTTOM OF THE PAVEMENT STRUCTURE

** FOR DIFFERENT CORRUGATIONS AND ARCH PIPES REFER TO ROADWAY DESIGN MANUAL OR MANUFACTURERS SPECIFICATION.

REFER TO THE FOLLOWING FOR PIPE SPECIFICATIONS

- CSP - AASHTO M36
- CAAP - AASHTO M196
- HDPE - AASHTO M294
- PVC - ASTM F949 or AASHTO M304

NOTES: FILL HEIGHTS SHOWN WERE CALCULATED USING AASHTO LRFD BRIDGE DESIGN SPECIFICATIONS
1' MINIMUM COVER FOR ALL SIDE DRAIN PIPE IN ACCORDANCE WITH THE STANDARD SPECIFICATIONS

RIGID PIPE

- RCP - * (Minimum fill) 1' for Class IV & CLASS V
- 2' for Class III & Class II
- * (Maximum fill) 10' - Class II pipe
- 20' - Class III pipe
- 30' - Class IV pipe
- 40' - Class V pipe

(For fills > 40' & < 80' use LRFD Direct Design Method)

* FILL HEIGHT IS MEASURED FROM THE TOP OF THE PIPE TO THE BOTTOM OF THE PAVEMENT STRUCTURE

REFER TO THE FOLLOWING FOR PIPE SPECIFICATIONS

- RCP - AASHTO M170

NOTES: FILL HEIGHTS SHOWN WERE CALCULATED USING AASHTO LRFD BRIDGE DESIGN SPECIFICATIONS
1' MINIMUM COVER FOR ALL SIDE DRAIN PIPE IN ACCORDANCE WITH THE STANDARD SPECIFICATIONS

PROJECT SERVICES UNIT
STANDARDS AND SPECIAL DESIGN
Office 919-250-4128 FAX 919-250-4119

SEE PLATE FOR TITLE

ORIGINAL BY: K Kempf DATE: 5-15-09
MODIFIED BY: *[Signature]* DATE: *[Signature]*
CHECKED BY: *[Signature]* DATE: 7/20/09
FILE SPEC: eroward/stds/stdsdetail/30001/0300d01.dgn

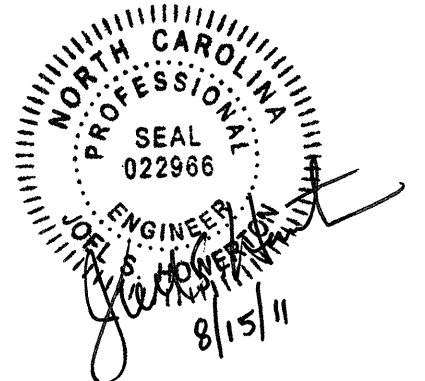

STATE OF NORTH CAROLINA
DEPT. OF TRANSPORTATION
DIVISION OF HIGHWAYS
RALEIGH, N.C.

ENGLISH DETAIL DRAWING FOR
ANCHORAGE FOR FRAMES
BRICK/CONCRETE/PRECAST CONCRETE

SHEET 1 OF 1
840D25

STATE OF NORTH CAROLINA
DEPT. OF TRANSPORTATION
DIVISION OF HIGHWAYS
RALEIGH, N.C.

ENGLISH DETAIL DRAWING FOR
ANCHORAGE FOR FRAMES
BRICK/CONCRETE/PRECAST CONCRETE

SHEET 1 OF 1
840D25

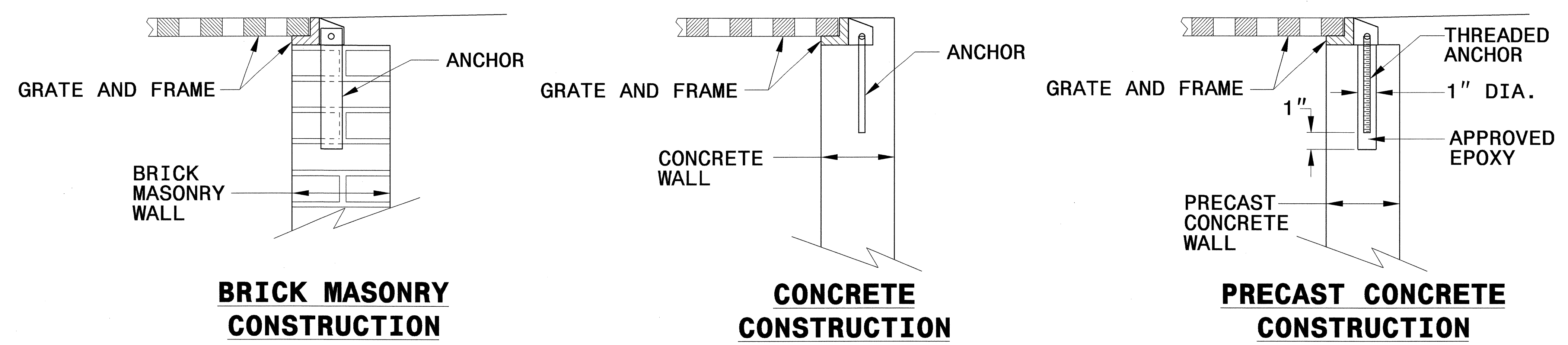

DETAIL SHOWING ANCHORAGE OF FRAME FOR GRATED DROP INLET

NOTE:
CONSTRUCT GRATED DROP INLET TO COINCIDE WITH NORMAL OR SUPERELEVATED SHOULDER OR PAVEMENT SLOPE.

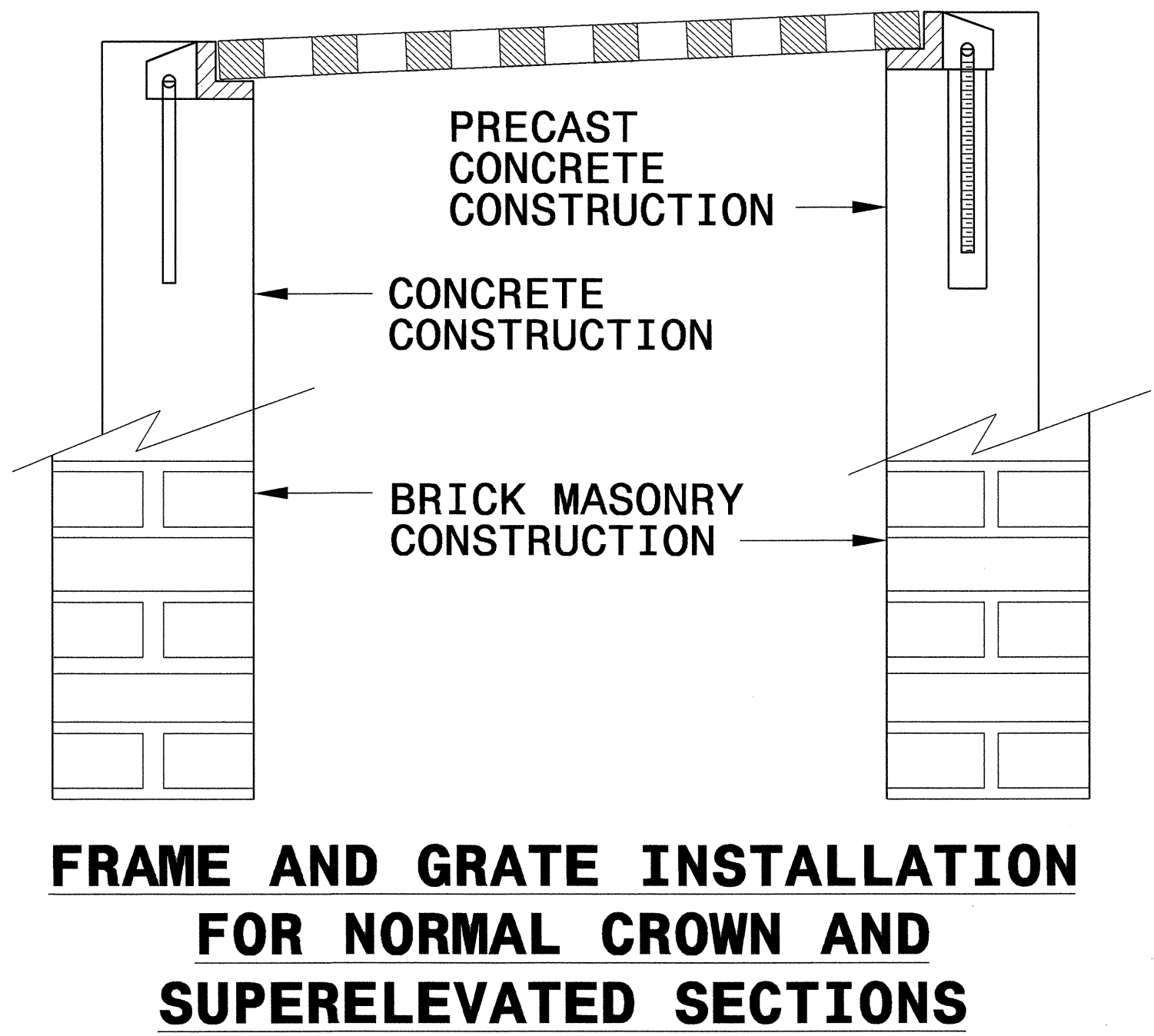
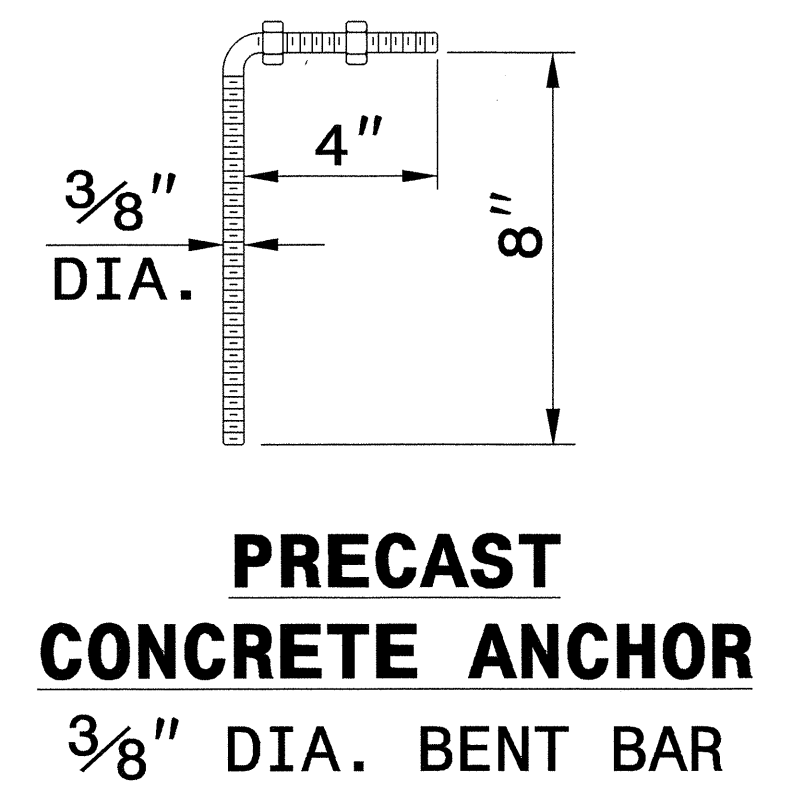
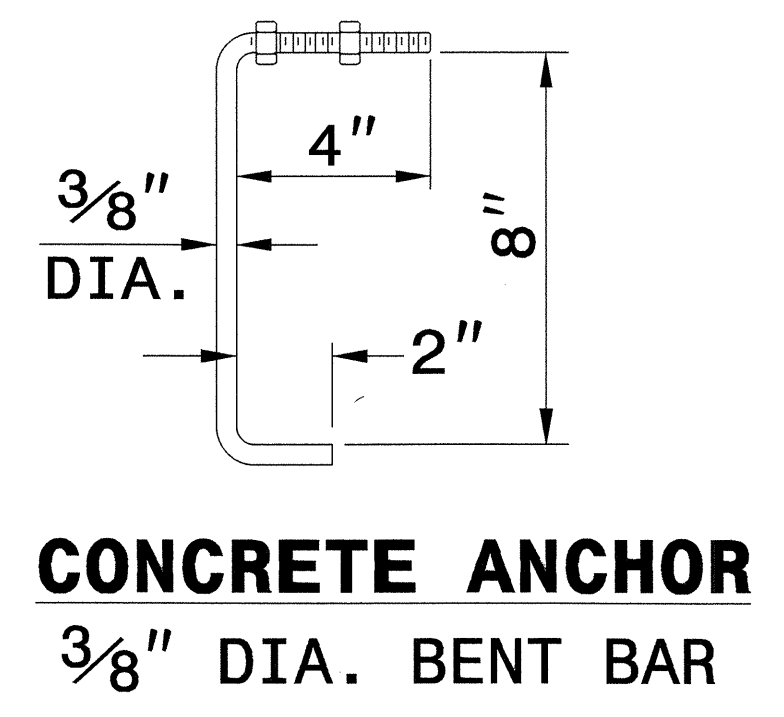
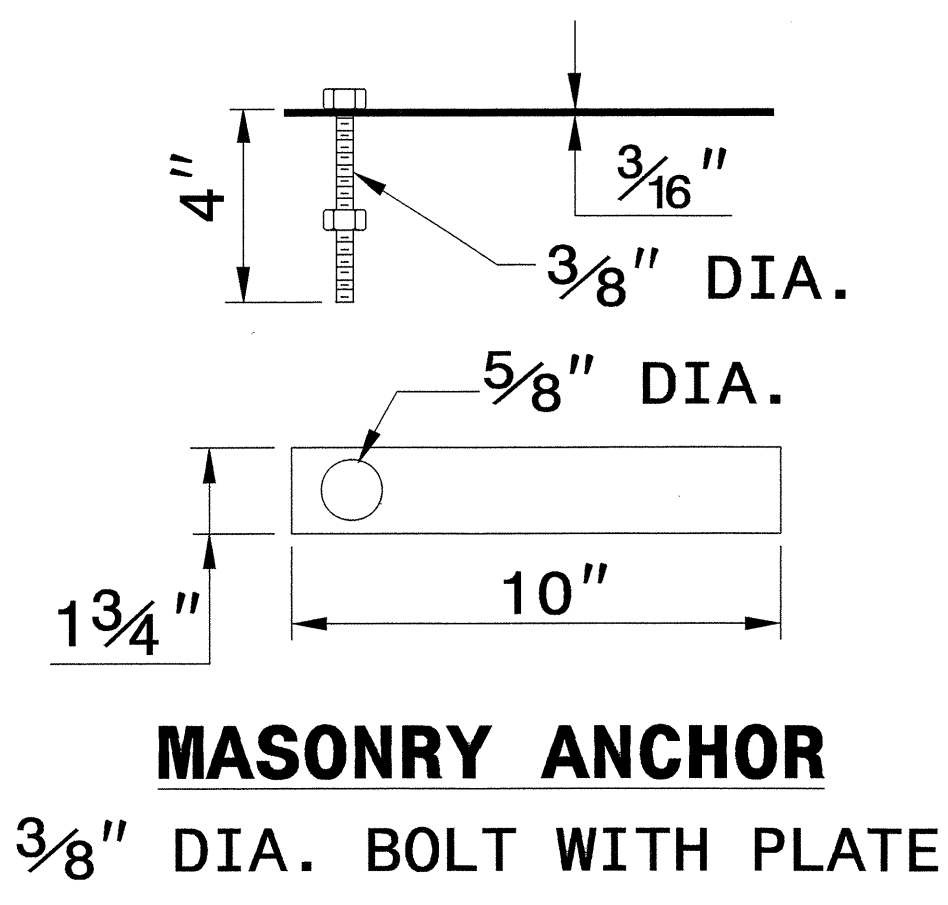

11/15/06 10:51 AM
 C:\PROJECTS\840D25\840D25.DWG
 840D25.DWG
 11/15/06 10:51 AM
 840D25.DWG
 11/15/06 10:51 AM

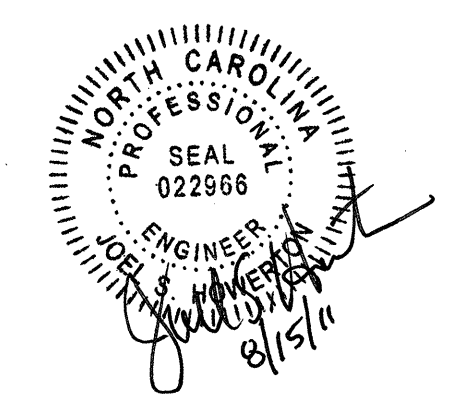

PROJECT SERVICES UNIT
STANDARDS AND SPECIAL DESIGN
Office 919-250-4128 FAX 919-250-4119

SEE PLATE FOR TITLE

ORIGINAL BY: 2006 STD 840.25 DATE: 07/18/06
 MODIFIED BY: E.E. WARD DATE: 9/25/06
 CHECKED BY: DATE:
 FILE SPEC.:

STATE OF NORTH CAROLINA
DEPT. OF TRANSPORTATION
DIVISION OF HIGHWAYS
RALEIGH, N.C.

ENGLISH DETAIL DRAWING FOR
BRIDGE APPROACH FILLS
CORED SLAB & BOX BEAM BRIDGES
SUB REGIONAL TIER

SHEET 1 OF 2
422D11

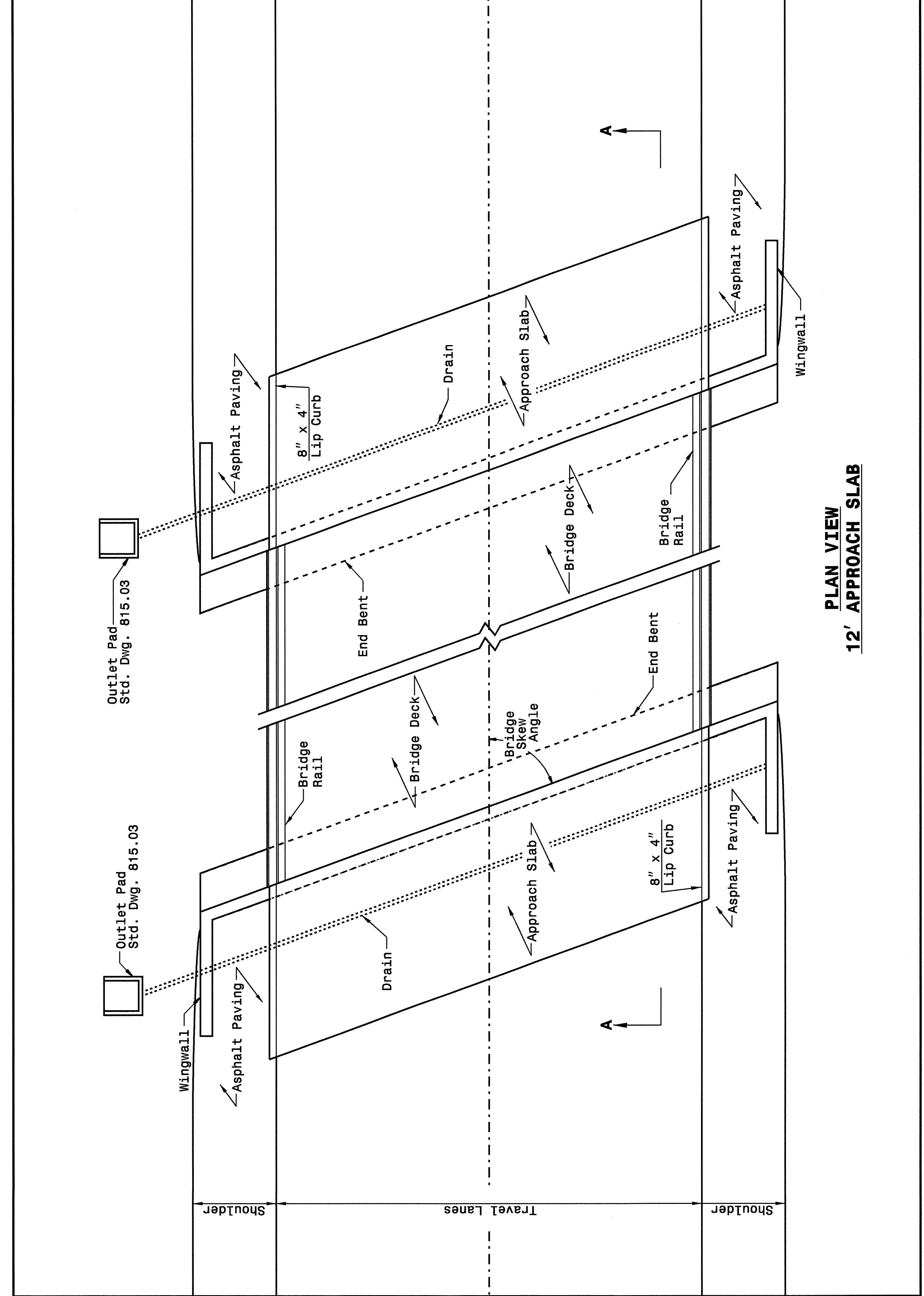

STATE OF NORTH CAROLINA
DEPT. OF TRANSPORTATION
DIVISION OF HIGHWAYS
RALEIGH, N.C.

ENGLISH DETAIL DRAWING FOR
BRIDGE APPROACH FILLS
CORED SLAB & BOX BEAM BRIDGES
SUB REGIONAL TIER

SHEET 1 OF 2
422D11

STATE OF NORTH CAROLINA
DEPT. OF TRANSPORTATION
DIVISION OF HIGHWAYS
RALEIGH, N.C.

ENGLISH DETAIL DRAWING FOR
BRIDGE APPROACH FILLS
CORED SLAB & BOX BEAM BRIDGES
SUB REGIONAL TIER

SHEET 2 OF 2
422D11

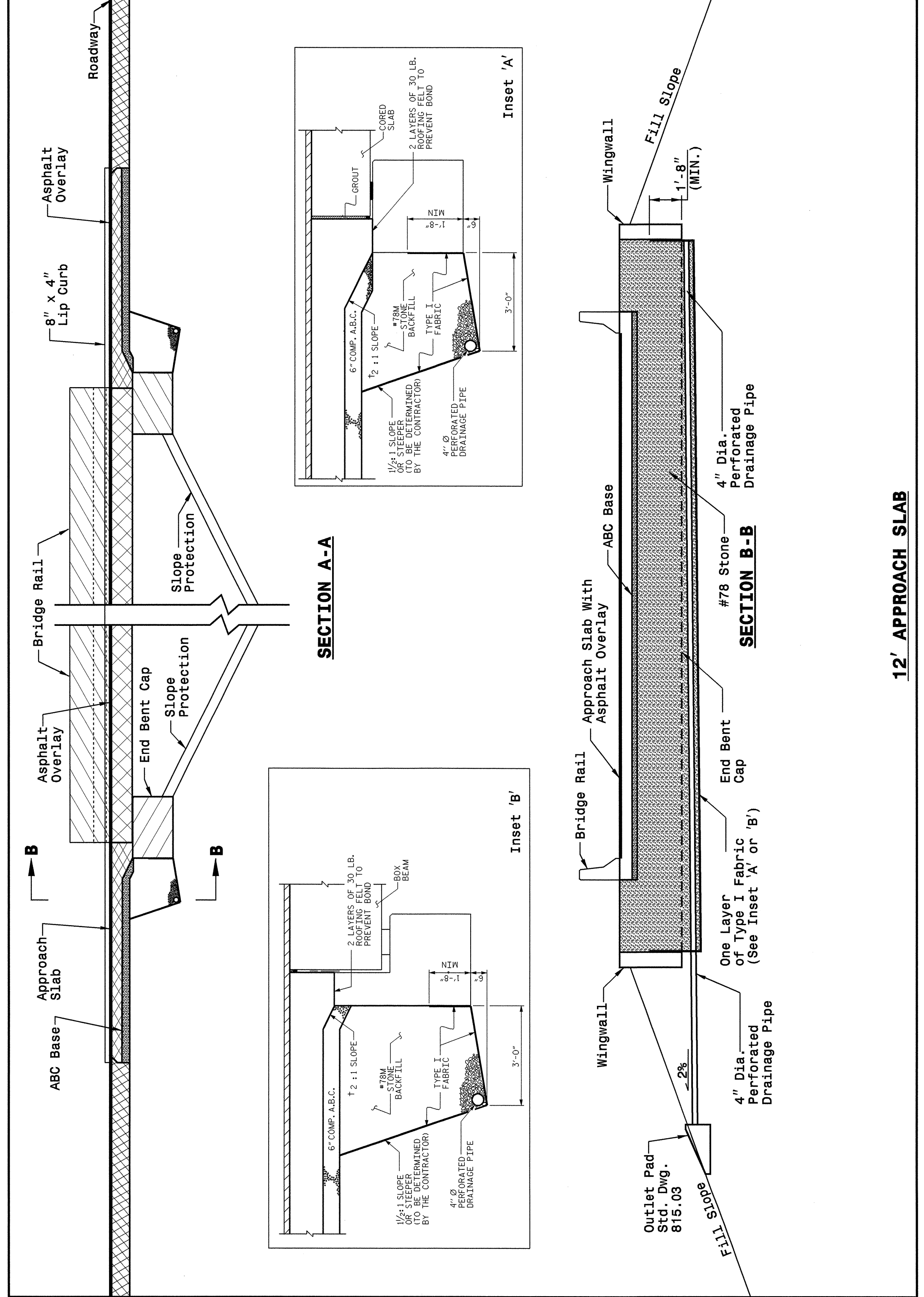

STATE OF NORTH CAROLINA
DEPT. OF TRANSPORTATION
DIVISION OF HIGHWAYS
RALEIGH, N.C.

ENGLISH DETAIL DRAWING FOR
BRIDGE APPROACH FILLS
CORED SLAB & BOX BEAM BRIDGES
SUB REGIONAL TIER

SHEET 2 OF 2
422D11

**PROJECT SERVICES UNIT
STANDARDS AND SPECIAL DESIGN**
Office 919-250-4128 FAX 919-250-4119

BRIDGE APPROACH FILLS
CORED SLAB & BOX BEAM BRIDGES
SUB REGIONAL TIER

ORIGINAL BY: K. A. Kempf DATE: 6-10-08
MODIFIED BY: DATE: _____
CHECKED BY: DATE: _____
FILE SPEC.: kkempf/english/bridge approach fills.dgn



28 DEC 2006 09:41
 S:\projects\contracts\special_details\verticalward\stds\06\stds to special_details\42211\bridge approach fill sub reg tier.dgn
 \$\$\$USERNAME\$\$\$

STATE OF NORTH CAROLINA
DIVISION OF HIGHWAYS

SUMMARY OF QUANTITIES

STATE OF NORTH CAROLINA
DIVISION OF HIGHWAYS
ROADWAY SUMMARY OF QUANTITIES FOR CONTRACT - C202732

ItemNumber	Sec #	Quantity	Unit	Description
000100000-N	800	Lump Sum		MOBILIZATION
000400000-N	801	Lump Sum		CONSTRUCTION SURVEYING
003000000-N	SP	Lump Sum		BRIDGE APPROACH FILL - SUB REGIONAL TIER, STATION ***** (19+20.00-L)
004300000-N	226	Lump Sum		GRADING
005000000-E	226	1	ACR	SUPPLEMENTARY CLEARING & GRUB-BING
005700000-E	226	300	CY	UNDERCUT EXCAVATION
019500000-E	SP	300	CY	SELECT GRANULAR MATERIAL
019600000-E	270	400	SY	FABRIC FOR SOIL STABILIZATION
031800000-E	SP	10	TON	FOUNDATION CONDITIONING MATERIAL, MINOR STRS
032000000-E	SP	20	SY	FOUNDATION CONDITIONING FABRIC
033520000-E	SP	10	LF	15" DRAINAGE PIPE
044820000-E	SP	24	LF	15" RC PIPE CULVERTS, CLASS IV
148900000-E	610	600	TON	ASPHALT CONC BASE COURSE, TYPE B25.0B
152500000-E	610	420	TON	ASPHALT CONC SURFACE COURSE, TYPE SF9.5A
157500000-E	SP	55	TON	ASPHALT BINDER FOR PLANT MIX
202200000-E	SP	45	CY	SUBDRAIN EXCAVATION
203300000-E	SP	34	CY	SUBDRAIN FINE AGGREGATE
204400000-E	SP	200	LF	6" PERFORATED SUBDRAIN PIPE
207000000-N	SP	1	EA	SUBDRAIN PIPE OUTLETS
207700000-E	SP	6	LF	6" OUTLET PIPE (SUBDRAINS)
228600000-N	840	2	EA	MASONRY DRAINAGE STRUCTURES
236700000-N	840	2	EA	FRAME WITH TWO GRATES, STD 840.29
255600000-E	846	100	LF	SHOULDER BERM GUTTER
303000000-E	862	75	LF	STEEL BM GUARDRAIL
315000000-N	862	5	EA	ADDITIONAL GUARDRAIL POSTS
321500000-N	862	4	EA	GUARDRAIL ANCHOR UNITS, TYPE III

ItemNumber	Sec #	Quantity	Unit	Description
327000000-N	SP	4	EA	GUARDRAIL ANCHOR UNITS, TYPE 350
365600000-E	876	375	SY	FILTER FABRIC FOR DRAINAGE
365900000-N	SP	1	EA	PREFORMED SCOUR HOLES WITH LEVEL SPREADER APRON
440000000-E	1110	329	SF	WORK ZONE SIGNS (STATIONARY)
441000000-E	1110	57	SF	WORK ZONE SIGNS (BARRICADE MOUNTED)
444500000-E	1145	80	LF	BARRICADES (TYPE III)
481000000-E	1205	9,400	LF	PAINT PAVEMENT MARKING LINES (4")
490000000-N	1251	15	EA	PERMANENT RAISED PAVEMENT MARKERS
600000000-E	1605	2,350	LF	TEMPORARY SILT FENCE
600600000-E	1610	160	TON	STONE FOR EROSION CONTROL, CLASS A
600900000-E	1610	50	TON	STONE FOR EROSION CONTROL, CLASS B
601200000-E	1610	60	TON	SEDIMENT CONTROL STONE
601500000-E	1615	1	ACR	TEMPORARY MULCHING
601800000-E	1620	100	LB	SEED FOR TEMPORARY SEEDING
602100000-E	1620	1.25	TON	FERTILIZER FOR TEMPORARY SEEDING
602400000-E	1622	100	LF	TEMPORARY SLOPE DRAINS
602700000-N	1622	4	EA	INLET PROTECTION AT TEMPORARY SLOPE DRAINS
602900000-E	SP	400	LF	SAFETY FENCE
603000000-E	1630	120	CY	SILT EXCAVATION
603600000-E	1631	2,100	SY	MATTING FOR EROSION CONTROL
603700000-E	SP	510	SY	COIR FIBER MAT
603800000-E	SP	250	SY	PERMANENT SOIL REINFORCEMENT MAT
604200000-E	1632	150	LF	1/4" HARDWARE CLOTH
604800000-E	SP	75	SY	FLOATING TURBIDITY CURTAIN
607101000-E	SP	170	LF	WATTLE

ItemNumber	Sec #	Quantity	Unit	Description
607101200-E	SP	120	LF	COIR FIBER WATTLE
607102000-E	SP	25	LB	POLYACRYLAMIDE (PAM)
607103000-E	SP	55	LF	COIR FIBER BAFFLE
607105000-E	SP	1	EA	*** SKIMMER (1-1/2")
608400000-E	1660	3	ACR	SEEDING & MULCHING
608700000-E	1660	0.5	ACR	MOWING
609000000-E	1661	50	LB	SEED FOR REPAIR SEEDING
609300000-E	1661	0.25	TON	FERTILIZER FOR REPAIR SEEDING
609600000-E	1662	50	LB	SEED FOR SUPPLEMENTAL SEEDING
610800000-E	1665	1.25	TON	FERTILIZER TOPDRESSING
611450000-N	SP	30	MHR	SPECIALIZED HAND MOWING
611700000-N	SP	25	EA	RESPONSE FOR EROSION CONTROL

5/28/99

28-JUL-2011 09:43
N:\4542.rdl.sum.dgn

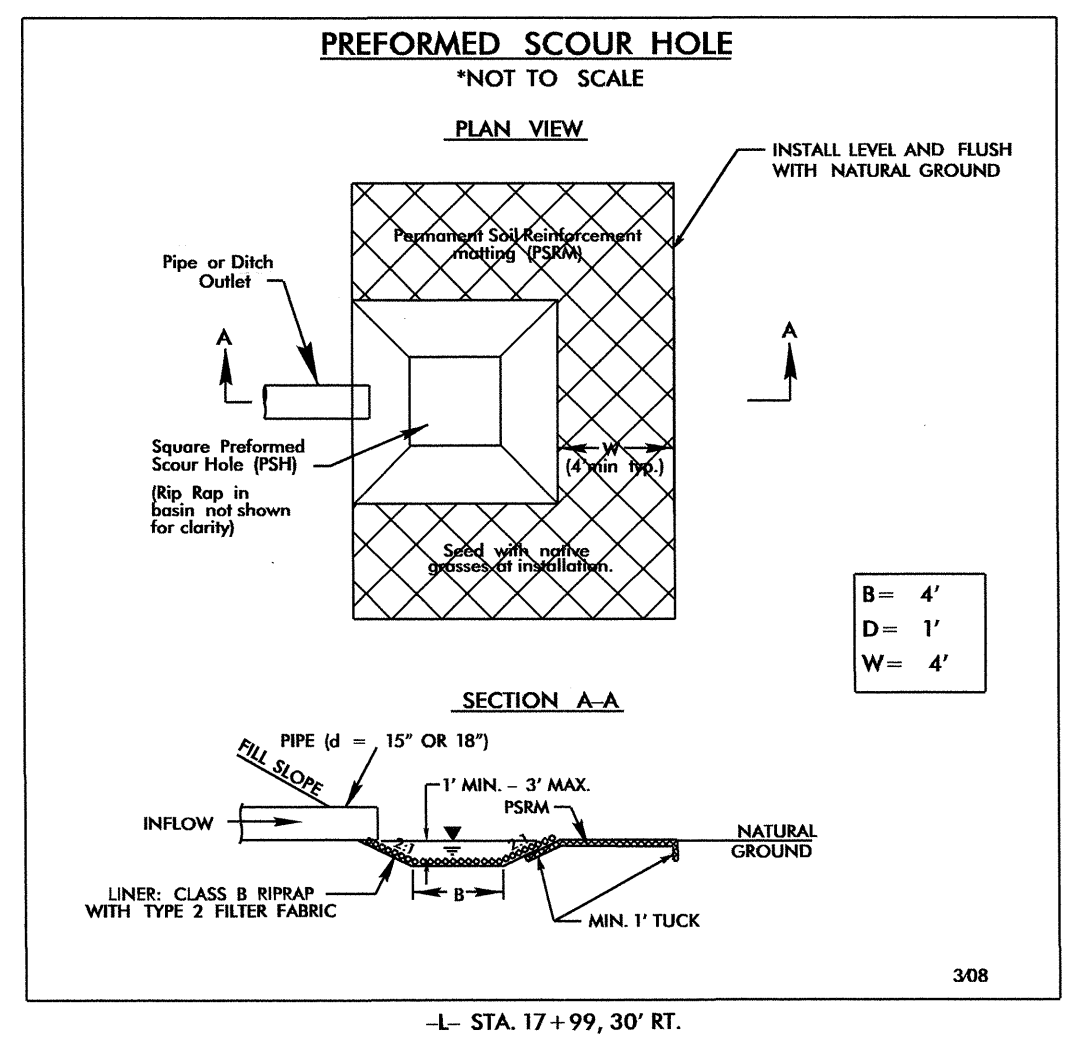
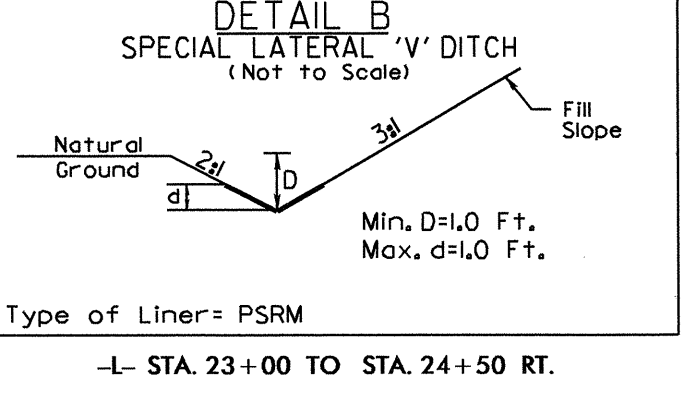
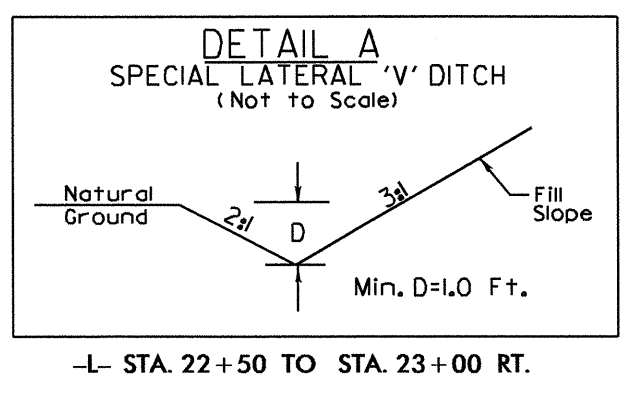
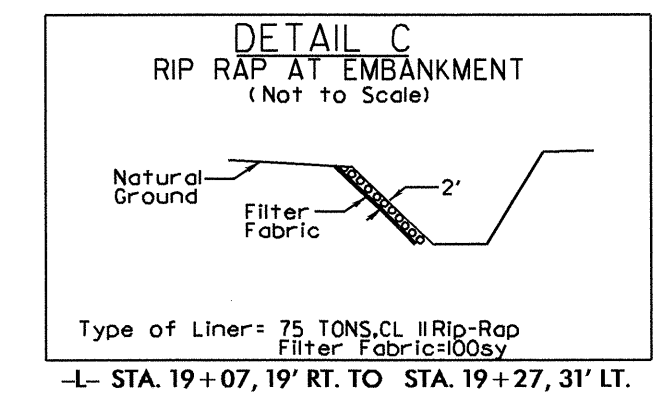
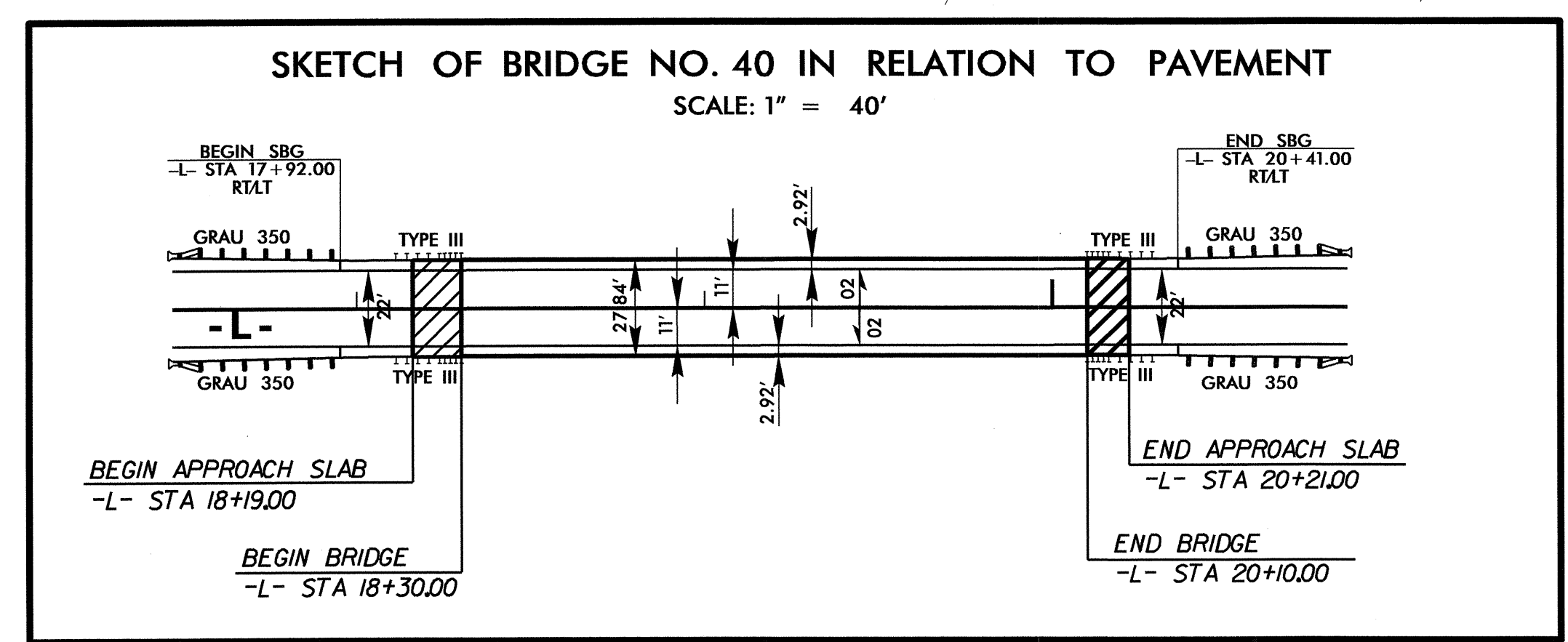
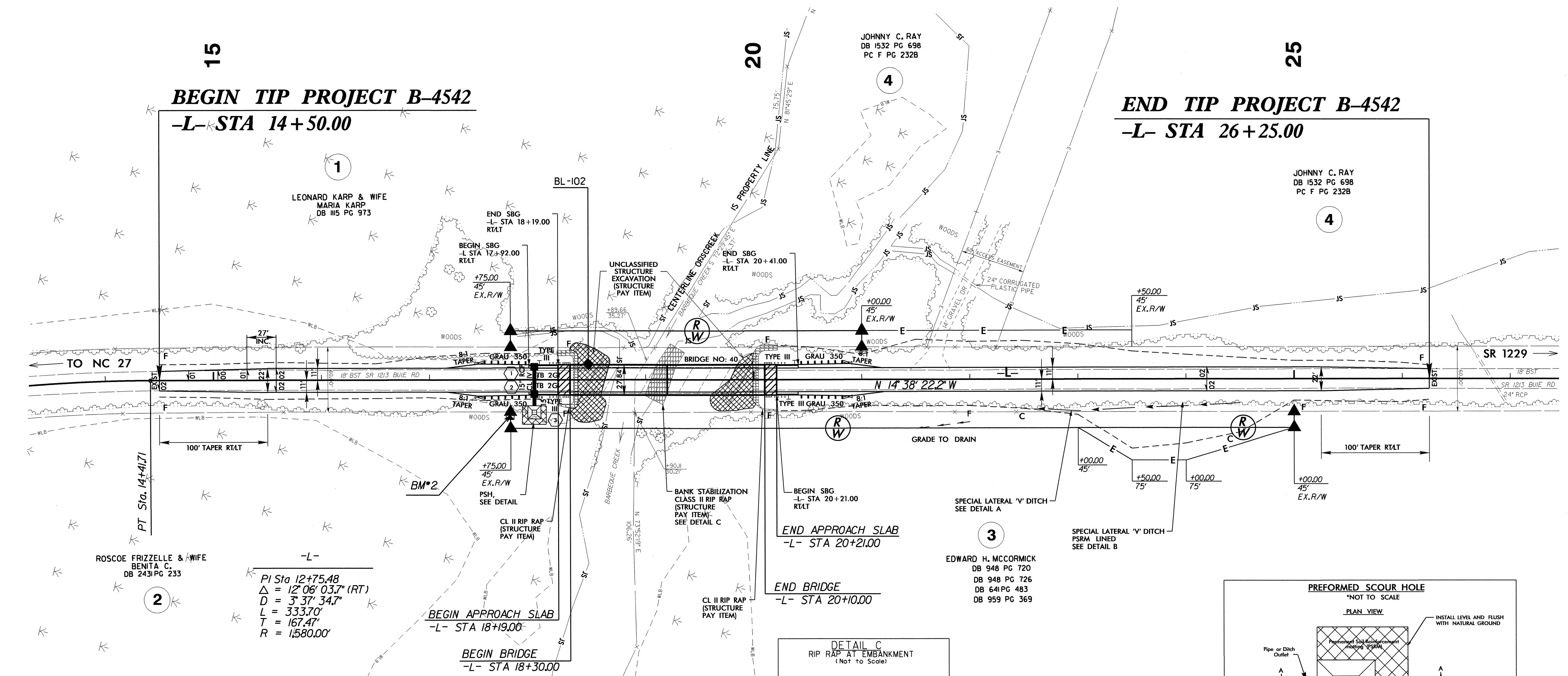

FOR -L- PROFILE, SEE SHEET 5
FOR STRUCTURE PLANS, SEE SHEETS S-1 TO S-22

09-SEP-2011 12:17 R:\roscoe\psh\4542.rdy.psh_4.dgn

