

STATE OF NORTH CAROLINA
DEPARTMENT OF TRANSPORTATION



TIP NO.	SHEET NO.
R-2414B	PMP-1
APPROVED: <i>Bob A May</i>	
DATE: 10/21/11	
SEAL	

PAVEMENT MARKING PLAN
CAMDEN COUNTY

T.I.P.: R-2414B

INDEX

SHEET NO.	DESCRIPTION
PMP-1	PAVEMENT MARKING PLAN COVER SHEET
PMP-2	PAVEMENT MARKING SCHEDULE
PMP-3 - 11	PAVEMENT MARKING DETAIL

ROADWAY STANDARD DRAWING

THE FOLLOWING ROADWAY STANDARDS AS APPEAR IN "ROADWAY STANDARD DRAWINGS" - PROJECT SERVICES UNIT - N.C. DEPARTMENT OF TRANSPORTATION - RALEIGH, N.C., DATED JULY 2006 ARE APPLICABLE TO THIS PROJECT AND BY REFERENCE HEREBY ARE CONSIDERED A PART OF THESE PLANS:

STD. NO.	TITLE
1205.01	PAVEMENT MARKINGS - LINE TYPES AND OFFSETS
1205.02	PAVEMENT MARKINGS - 2 LANE AND MULTILANE ROADWAYS
1205.04	PAVEMENT MARKINGS - INTERSECTIONS
1205.05	PAVEMENT MARKINGS - TURN LANES
1205.06	PAVEMENT MARKINGS - THRU LANE DROPS
1205.07	PAVEMENT MARKINGS - PEDESTRIAN CROSSINGS
1205.08	PAVEMENT MARKINGS - SYMBOL AND WORD MESSAGES
1205.09	PAVEMENT MARKINGS - PAINTED ISLANDS
1205.11	PAVEMENT MARKINGS - RAILROAD CROSSINGS
1250.01	PAVEMENT MARKER SPACING
1251.01	RAISED PAVEMENT MARKERS - TEMPORARY AND PERMANENT
1261.01	GUARDRAIL AND BARRIER DELINEATOR SPACING
1261.02	GUARDRAIL AND BARRIER DELINEATOR TYPES
1262.01	GUARDRAIL END DELINEATION
1264.02	PLACEMENT OF OBJECT MARKERS

GENERAL NOTES

THE FOLLOWING GENERAL NOTES APPLY AT ALL TIMES FOR THE DURATION OF THE CONSTRUCTION PROJECT, EXCEPT WHEN OTHERWISE NOTED IN THE PLAN, OR DIRECTED BY THE ENGINEER.

A) INSTALL PAVEMENT MARKINGS AND PAVEMENT MARKERS ON THE FINAL SURFACE AS FOLLOWS:

ROAD NAME	MARKING	MARKER
1. -L- (US 158)	THERMOPLASTIC	PERMANENT RAISED
2. -Y- LINES	THERMOPLASTIC	PERMANENT RAISED

- B) TIE PROPOSED PAVEMENT MARKING LINES TO EXISTING PAVEMENT MARKING LINES.
- C) REMOVE/REPLACE ANY CONFLICTING/DAMAGED PAVEMENT MARKINGS AND MARKERS.
- D) PASSING ZONES WILL BE DETERMINED IN THE FIELD AND MUST BE APPROVED BY THE ENGINEER.
- E) STOP BAR LOCATION AT NON -SIGNALIZED INTERSECTIONS MAY BE ADJUSTED AS DIRECTED BY THE ENGINEER.
- F) MARKERS SHALL BE INSTALLED ACCORDING TO THE NC DOT ROADWAY STANDARD DRAWING 1250.01.

PLAN REVIEWED BY: N.C.D.O.T. SIGNING AND DELINEATION UNIT

CHRIS HOWARD SIGNING & DELINEATION STANDARDS ENGINEER
MARK MANRIQUEZ SIGNING & DELINEATION PROJECT DESIGN ENGINEER

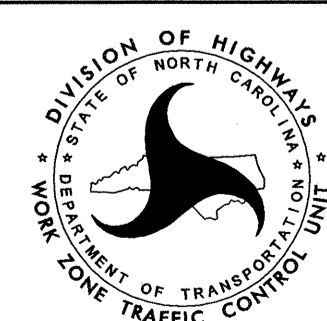

PLAN PREPARED BY:

BOB MAY, P.E. ROADWAY PROJECT ENGINEER
CHARLES MULLEN TRAFFIC CONTROL/PAVEMENT MARKING SPECIALIST

WETHERILL ENGINEERING
559 Jones Franklin Rd. Suite 164
Raleigh, N.C. 27606
Bus: 919 851 8077
Fax: 919 851 8107
License: F-0377

TRANSPORTATION PLANNING/DESIGN - BRIDGE/STRUCTURE DESIGN
CIVIL/SITE DESIGN - GIS/GPS - CONSTRUCTION OBSERVATION

PAVEMENT MARKING SCHEDULE

SYMBOL	DESCRIPTION	PAY ITEM
		FINAL PAVEMENT MARKINGS
		THERMOPLASTIC (100MM, 2.3MM)
TA	WHITE EDGELINE	
TB	YELLOW EDGELINE	
		THERMOPLASTIC (100MM, 3.1MM)
TC	3 M. WHITE SKIP	
TD	0.5 M. WHITE MINISKIP	
TE	WHITE SOLID LANE LINE	
TF	3 M. YELLOW SKIP	
TH	YELLOW SINGLE CENTER	
TI	YELLOW DOUBLE CENTER	
T8	0.5 M. WHITE MINISKIP	
		THERMOPLASTIC (200MM, 2.3MM)
TP	WHITE GORELINE	
TQ	WHITE DIAGONAL	
TT	YELLOW DIAGONAL	
		THERMOPLASTIC (400MM, 3.1MM)
T1	WHITE LINE, RR CROSSBAR	
		THERMOPLASTIC (600MM, 3.1MM)
T2	WHITE STOPBAR	
T3	WHITE CROSSWALK LINE (HIGH-VISIBILITY)	
		THERMOPLASTIC PAVEMENT MARKING CHARACTER (3.1MM)
UI	ALPHANUMERIC CHAR.	
		THERMOPLASTIC PAVEMENT MARKING SYMBOLS (2.3MM)
UA	LEFT TURN ARROW	
UB	RIGHT TURN ARROW	
UC	STRAIGHT ARROW	
UE	COMBO. STRAIGHT/RIGHT	
UF	COMBO. LEFT/RIGHT	
		MARKERS PERMANENT RAISED PAVEMENT MARKERS
MA	YELLOW & YELLOW	
MB	CRYSTAL & RED	



TIP NO. R-2414B	SHEET NO. PMP-2
APPROVED: <i>Bob A. May</i>	
DATE: 10/21/11	

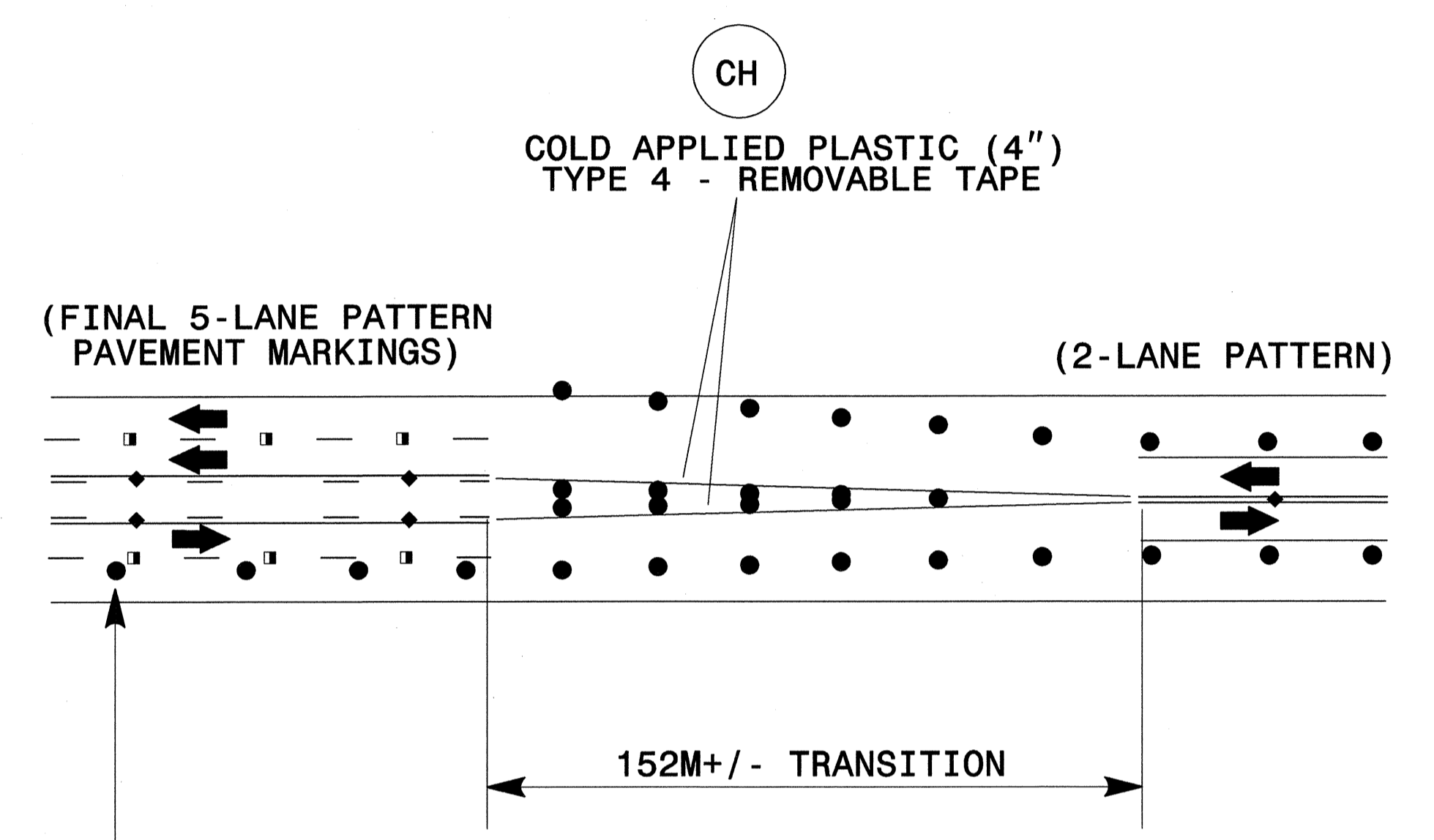

ROADWAY STANDARD DRAWING 1101.02, SHT. 3 OF 9
(RIGHT LANE CLOSURE)

US 158 FINAL PAVEMENT MARKING TRANSITION (AT THE END OF THE WORKDAY)

PAVEMENT MARKING SCHEDULE

10/18/2011 3:02:25 PM P:\R-2414B\TrafficControl\TCP\2414b_pm_psh2.dgn

559 Jones Franklin Rd. Suite 164
 Raleigh, N.C. 27606
 Bus: 919 851 8077
 Fax: 919 851 8107
 License: F-0377

TRANSPORTATION PLANNING/DESIGN - BRIDGE/STRUCTURE DESIGN
 CIVIL/SITE DESIGN - GIS/GPS - CONSTRUCTION OBSERVATION

TIP NO. R-2414B	SHEET NO. PMP-3
APPROVED: <i>Bl. A. Mey</i>	
DATE: 12-19-11	
SEAL	
	

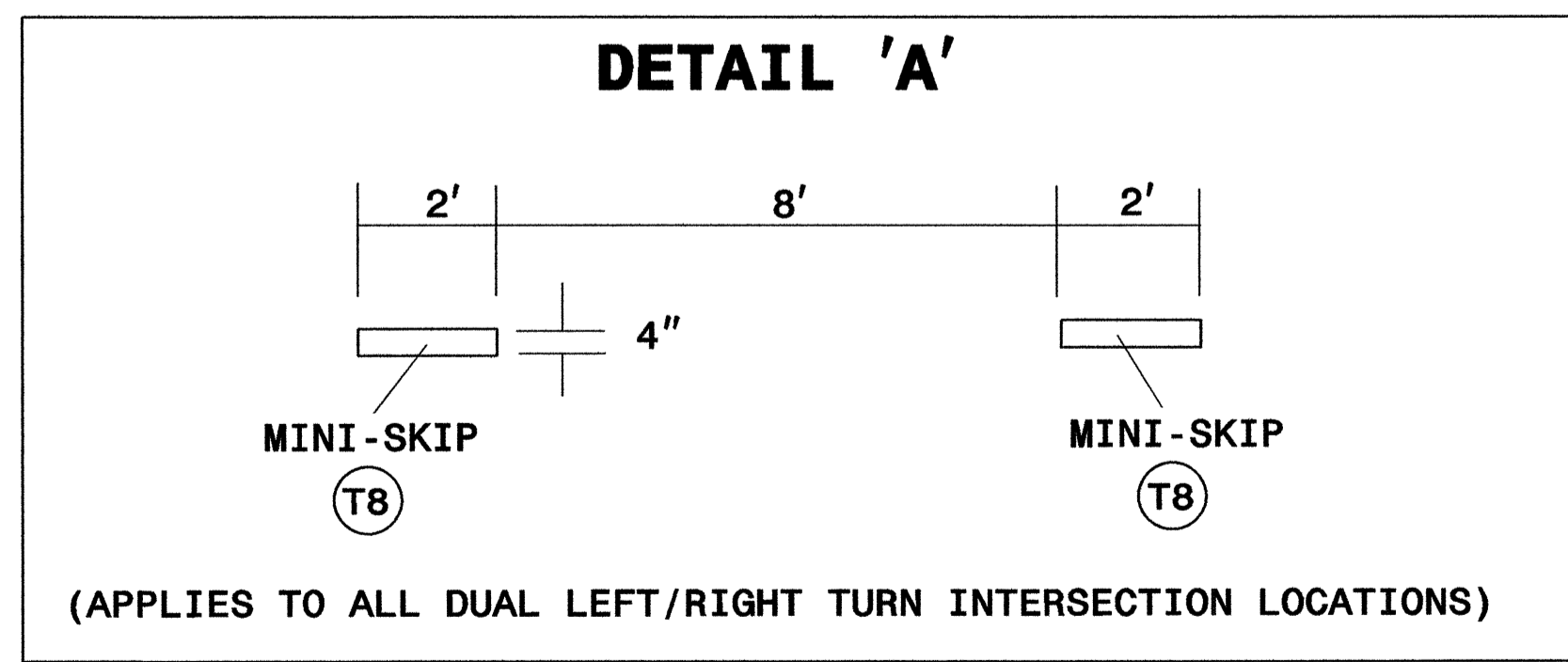
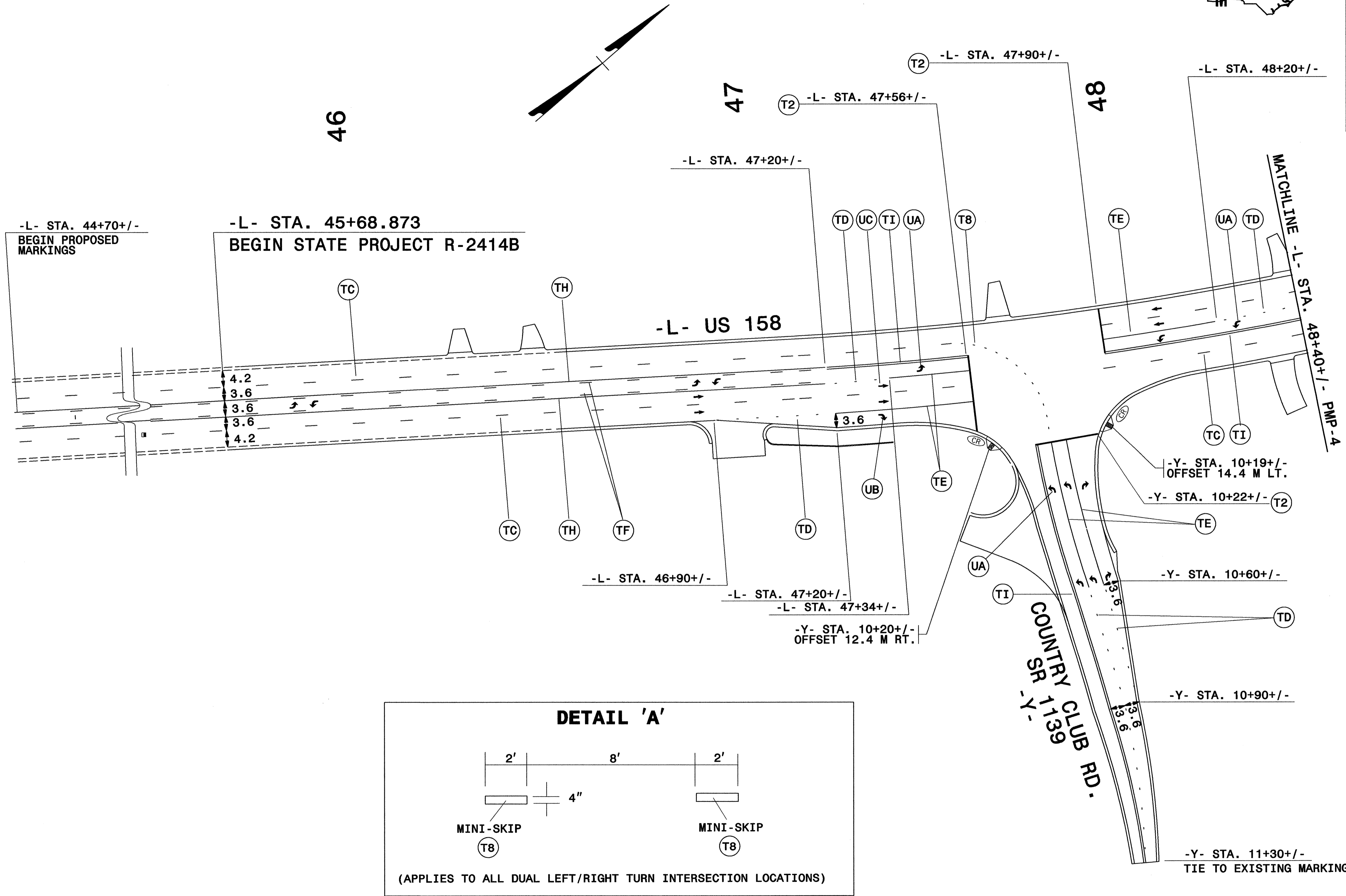

SEE PMP-2 FOR PAVEMENT MARKING SCHEDULE
SEE SIGNAL PLANS FOR PERMANENT SIGNAL DESIGN AT -Y-

PAVEMENT MARKING DETAIL

ETHERILL ENGINEERING

559 Jones Franklin Rd. Suite 164
Raleigh, N.C. 27606
Bus: 919 851 8077
Fax: 919 851 8107
License: F-0377

TRANSPORTATION PLANNING/DESIGN - BRIDGE/STRUCTURE DESIGN
CIVIL/SITE DESIGN - GIS/GPS - CONSTRUCTION OBSERVATION

12/19/2011
 P:\R-2414B\TraficControl\CP\2414B_pm_psh3.dgn

TIP NO. R-2414B	SHEET NO. PMP-4
APPROVED: <i>Bob A. May</i>	
DATE: 12-19-11	
SEAL	
	

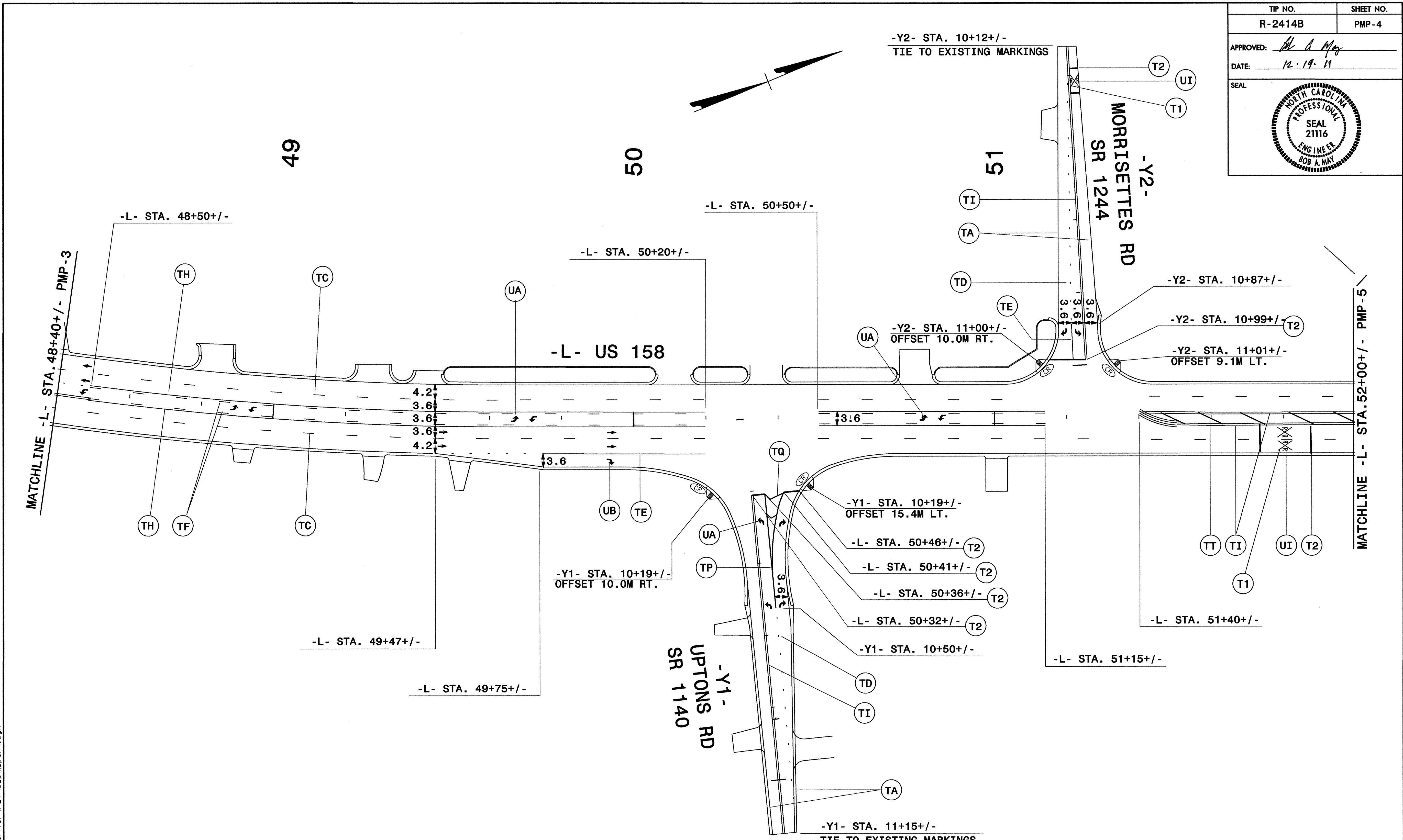

- SEE PMP-2 FOR PAVEMENT MARKING SCHEDULE

ETHERILL ENGINEERING
 559 Jones Franklin Rd, Suite 164
 Raleigh, N.C. 27606
 Bus: 919 851 8077
 Fax: 919 851 8107
 License: F-0377

TRANSPORTATION PLANNING/DESIGN - BRIDGE/STRUCTURE DESIGN
 CIVIL/SITE DESIGN - GIS/GPS - CONSTRUCTION OBSERVATION

PAVEMENT MARKING DETAIL

12/19/2011 10:53:33 AM P:\R-2414B\TrafficControl\CP\1244b_pm_psh4.dgn

TIP NO. R-2414B	SHEET NO. PMP-5
APPROVED: <i>Bob A. May</i>	
DATE: <i>11/21/11</i>	
SEAL	

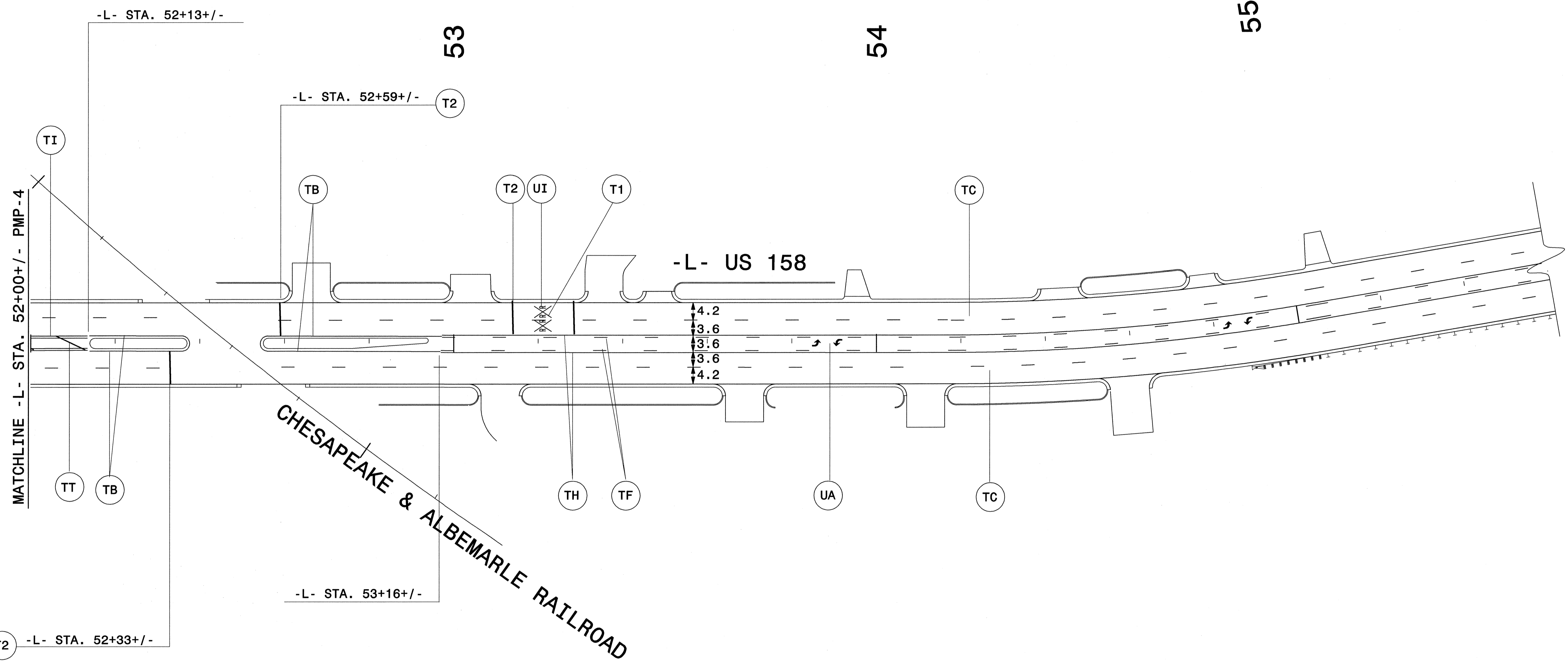
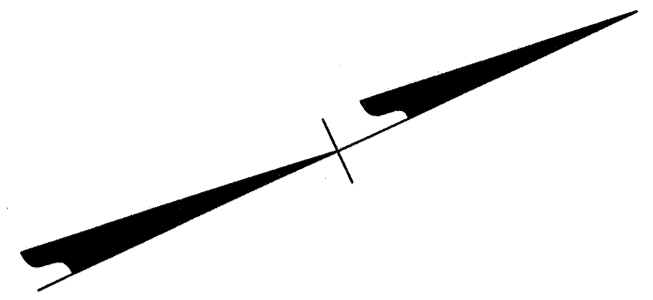

- SEE PMP-2 FOR PAVEMENT MARKING SCHEDULE
- SEE RSD 1205.08 & 1205.11 FOR MARKINGS AT RAILROAD CROSSINGS

10/18/2011 3:04:24 PM P:\R-2414B\TrafficControl\TCPV-2414b_pm_psh5.dgn

559 Jones Franklin Rd. Suite 164
 Raleigh, N.C. 27606
 Bus: 919 851 8077
 Fax: 919 851 8107
 License: F-0377

TRANSPORTATION PLANNING/DESIGN - BRIDGE/STRUCTURE DESIGN
 CIVIL/SITE DESIGN - GIS/GPS - CONSTRUCTION OBSERVATION

PAVEMENT MARKING DETAIL

TIP NO. R-2414B	SHEET NO. PMP-6
APPROVED: <i>Bob A. May</i>	
DATE: <i>10/18/11</i>	
SEAL	
	

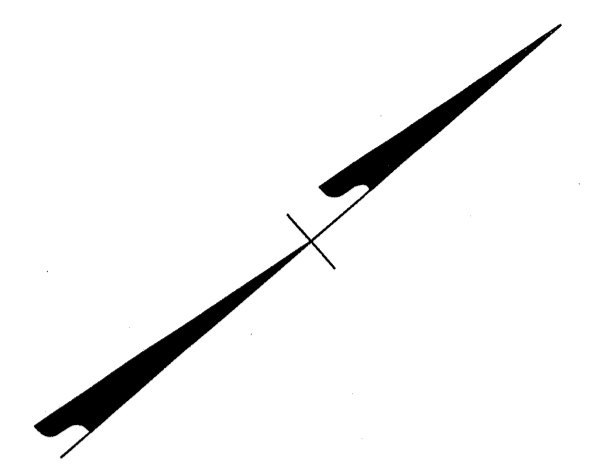
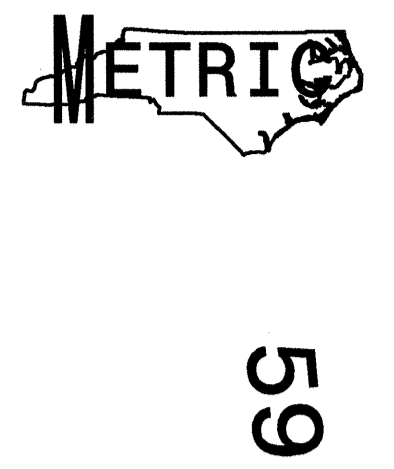

58

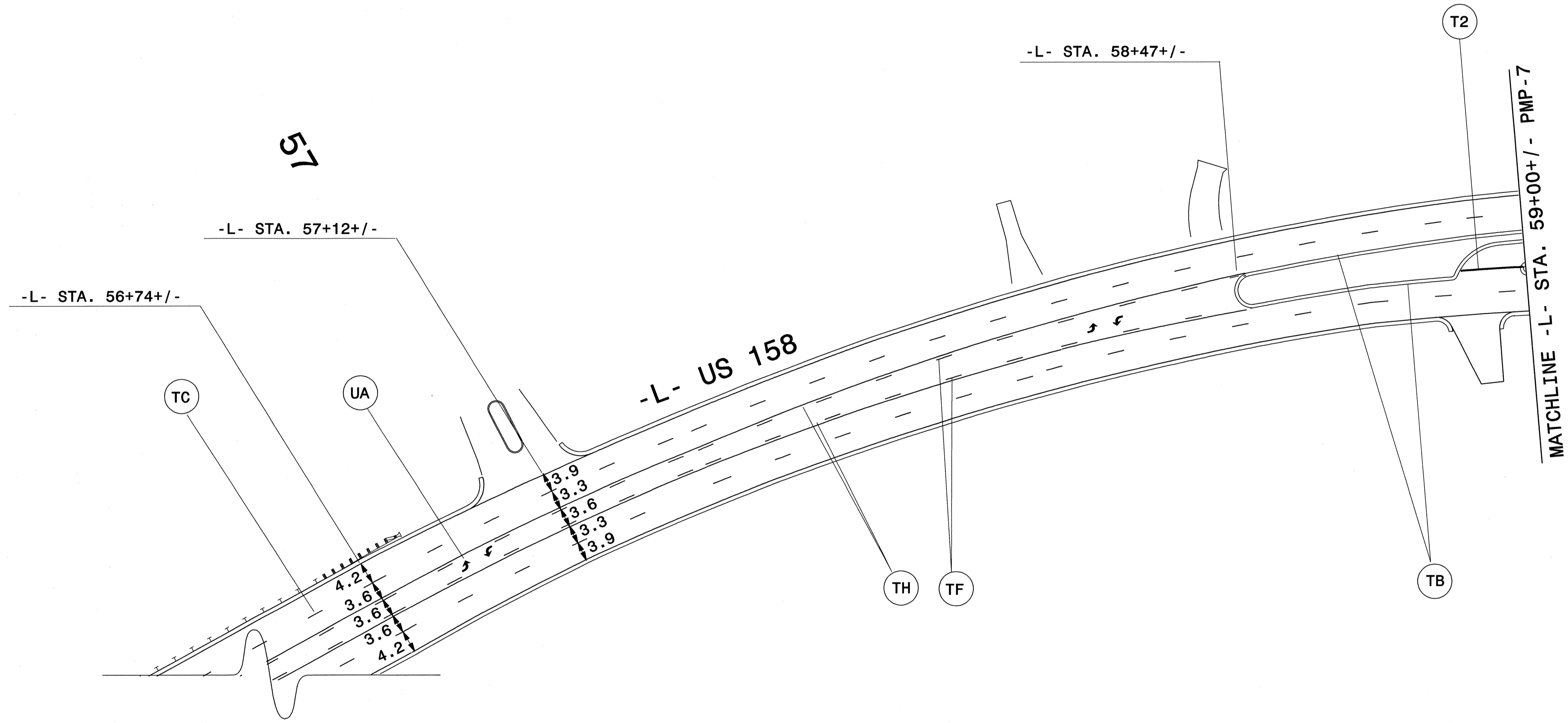

- SEE PMP-2 FOR PAVEMENT MARKING SCHEDULE
- SEE RSD 1205.09 FOR PAINTED ISLAND PAVEMENT MARKINGS

10/18/2011 3:04:57 PM P:\R-2414B\TrafficControl\TrafficControl\TCP\2414b_pm_psh6.dgn

WETHERILL ENGINEERING
 559 Jones Franklin Rd. Suite 164
 Raleigh, N.C. 27606
 Bus: 919 851 8077
 Fax: 919 851 8107
 License: F-0377

TRANSPORTATION PLANNING/DESIGN - BRIDGE/STRUCTURE DESIGN
 CIVIL/SITE DESIGN - GIS/GPS - CONSTRUCTION OBSERVATION

PAVEMENT MARKING DETAIL

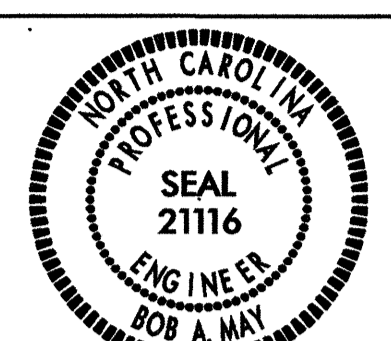
TIP NO.	SHEET NO.
R-2414B	PMP-7
APPROVED: <i>[Signature]</i>	
DATE: 12-19-11	
SEAL	
	

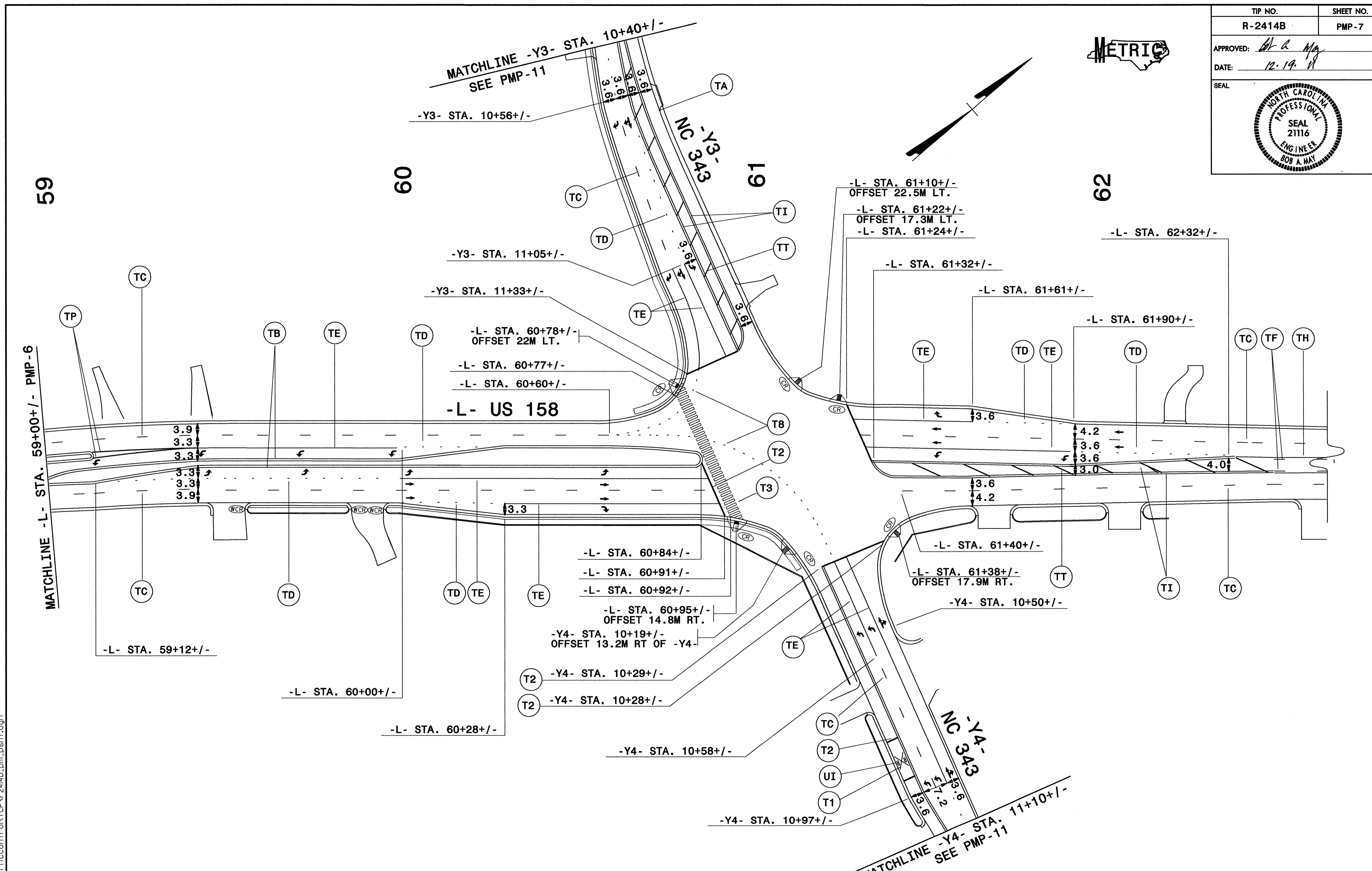

12/19/2011 2:00:03 PM
 P:\R-2414B\Traffic\TrafficContr\NCP\2414b_pm_pst7.dgn

 559 Jones Franklin Rd. Suite 164
 Raleigh, N.C. 27606
 Bus: 919 851 8077
 Fax: 919 851 8107
 License: F-0377
 TRANSPORTATION PLANNING/DESIGN - BRIDGE/STRUCTURE DESIGN
 CIVIL/SITE DESIGN - GIS/GPS - CONSTRUCTION OBSERVATION

- SEE 'DETAIL A' ON PMP-3 FOR (T8) MINI-SKIP PLACEMENT
- SEE PMP-2 FOR PAVEMENT MARKING SCHEDULE
- SEE SIGNAL PLANS FOR PERMANENT SIGNAL DESIGN AT NC 343
- LOCATE "RR" SYMBOL AT APPROXIMATE LOCATION OF EXISTING SYMBOL ON -Y4- (NC 343)

PAVEMENT MARKING DETAIL

TIP NO. R-2414B	SHEET NO. PMP-8
APPROVED: <i>Bob A. May</i>	
DATE: 12.19.11	
SEAL	

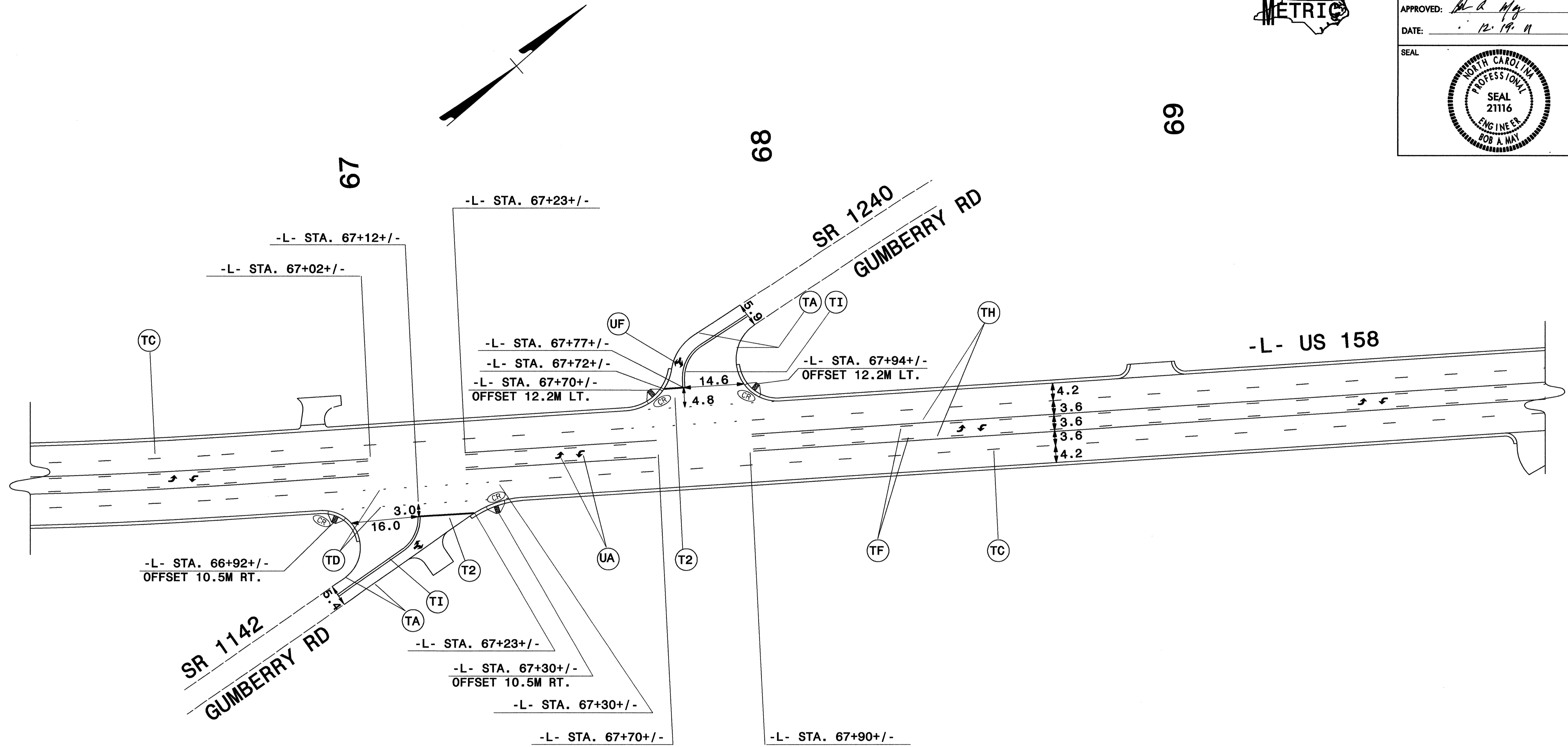

- SEE PMP-2 FOR PAVEMENT MARKING SCHEDULE

12/19/2011 2:00:33 PM P:\R-2414B\TrafficControl\TCPlan\2414b_pm_psf8.dgn

559 Jones Franklin Rd. Suite 164
 Raleigh, N.C. 27606
 Bus: 919 851 8077
 Fax: 919 851 8107
 License: F-0377

TRANSPORTATION PLANNING/DESIGN - BRIDGE/STRUCTURE DESIGN
 CIVIL/SITE DESIGN - GIS/GPS - CONSTRUCTION OBSERVATION

PAVEMENT MARKING DETAIL

TIP NO. R-2414B	SHEET NO. PMP-9
APPROVED: <i>Bob A. May</i>	
DATE: 12.19.11	
SEAL	
	

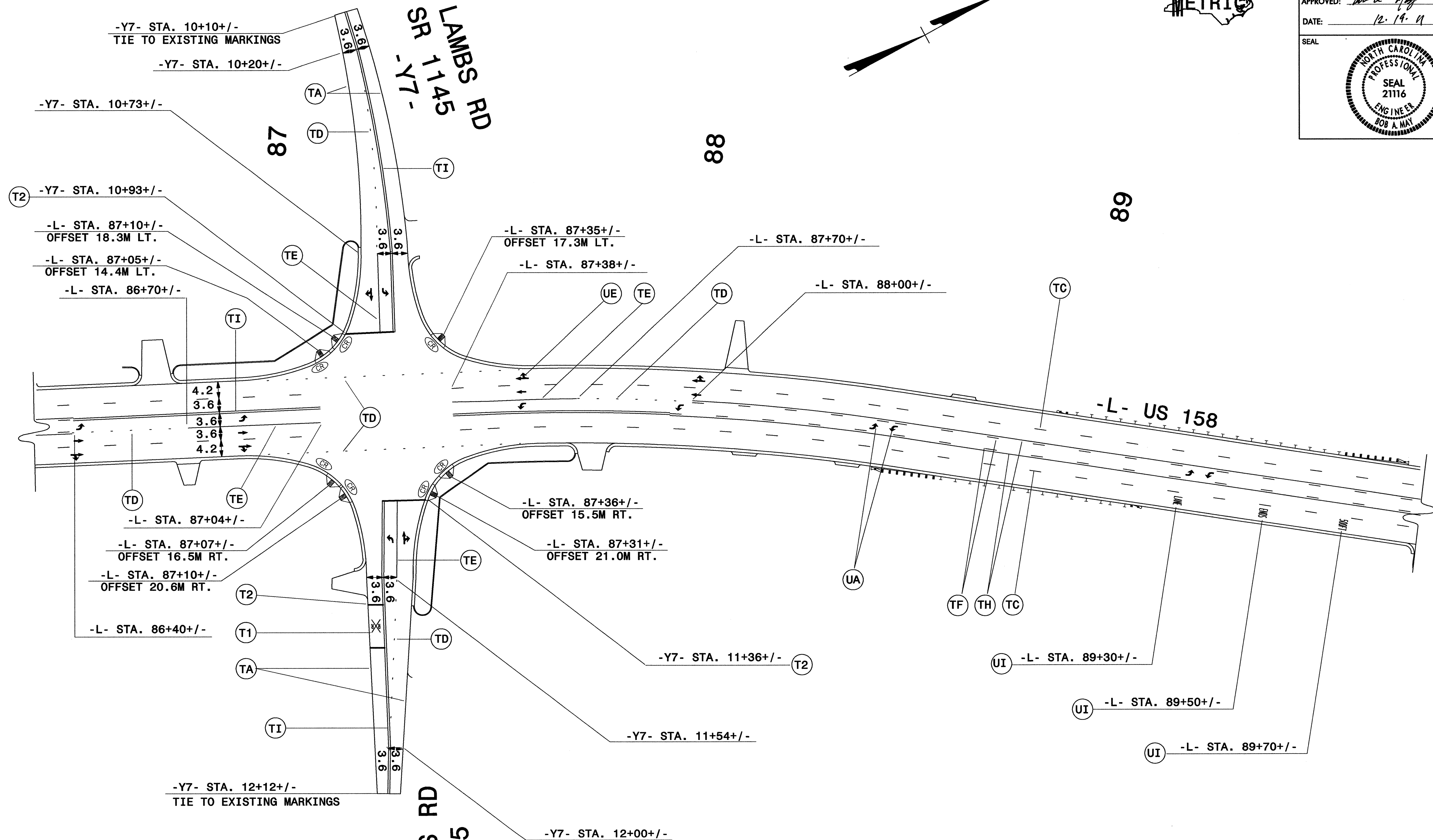
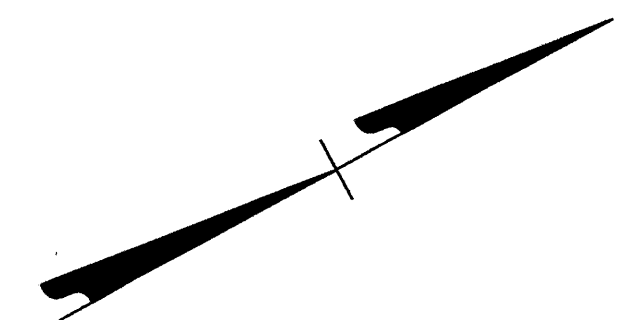

12/19/2011 10:24:05 AM
 P:\R-2414B\T-r-off-fic\Tr-off-fic\Control\CP\N-2414b_pm_psh9.dgn



 559 Jones Franklin Rd, Suite 164
 Raleigh, N.C. 27606
 Bus: 919 851 8077
 Fax: 919 851 8107
 License: F-0377

TRANSPORTATION PLANNING/DESIGN - BRIDGE/STRUCTURE DESIGN
 CIVIL/SITE DESIGN - GIS/GPS - CONSTRUCTION OBSERVATION

- SEE PMP-2 FOR PAVEMENT MARKING SCHEDULE
- SEE SIGNAL PLANS FOR PERMANENT FLASHING SIGNAL
- LOCATE "RR" SYMBOL AT APPROXIMATE LOCATION OF EXISTING SYMBOL ON -Y7- (BELCROSS RD.)

PAVEMENT MARKING DETAIL

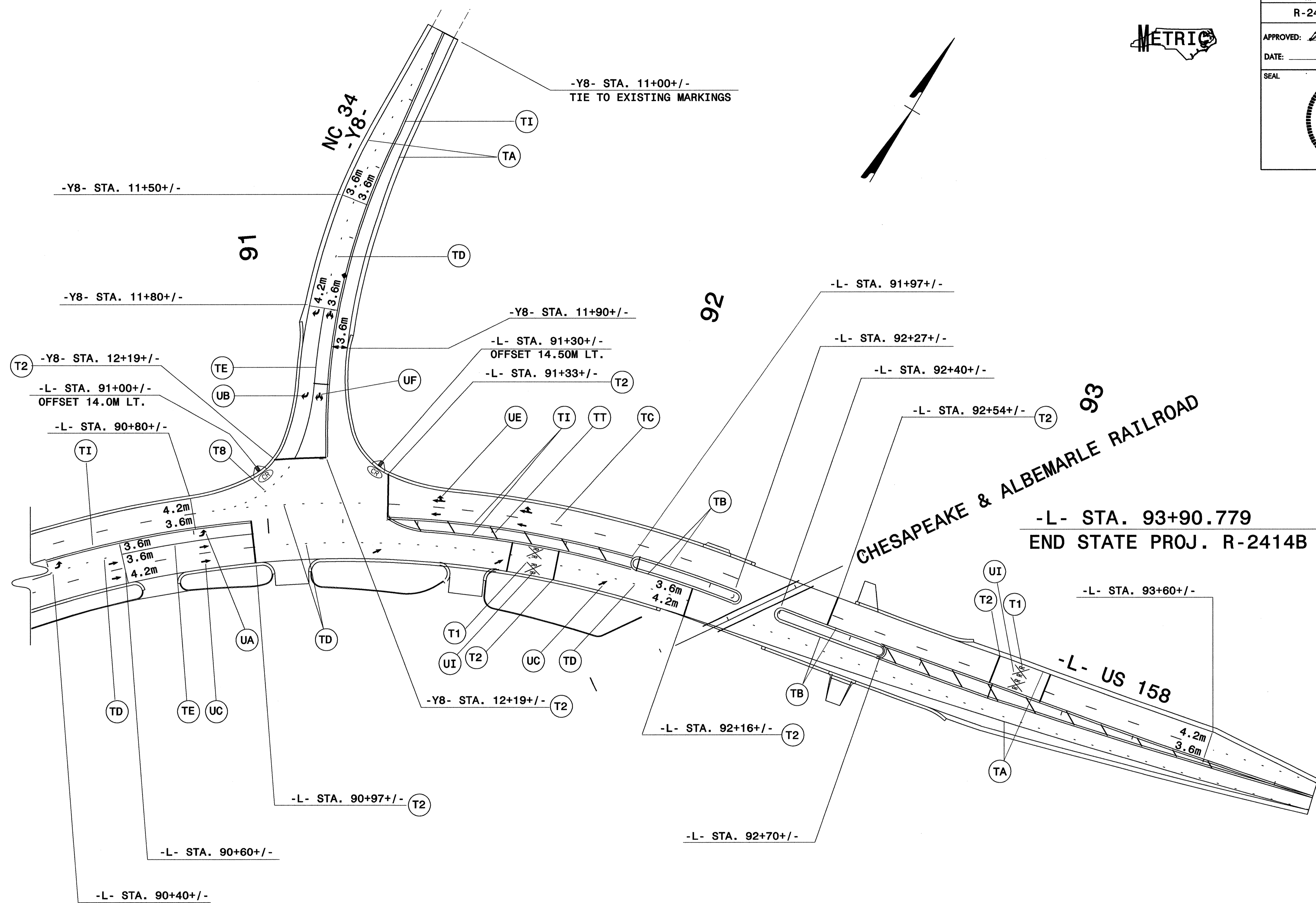
TIP NO.	SHEET NO.
R-2414B	PMP-10
APPROVED: <i>[Signature]</i>	
DATE: 12-19-11	
SEAL	
	



12/19/2011 2:01:22 PM P:\R-2414B\TrafficControl\TCP\2414B.pm_psh0.dgn

 559 Jones Franklin Rd. Suite 164
 Raleigh, N.C. 27606
 Bus: 919 851 8077
 Fax: 919 851 8107
 License: F-0377
 TRANSPORTATION PLANNING/DESIGN - BRIDGE/STRUCTURE DESIGN
 CIVIL/SITE DESIGN - GIS/GPS - CONSTRUCTION OBSERVATION

- SEE 'DETAIL A' ON PMP-3 FOR (T8) MINI-SKIP PLACEMENT
- SEE PMP-2 FOR PAVEMENT MARKING SCHEDULE
- SEE SIGNAL PLANS FOR PERMANENT SIGNAL DESIGN
- SEE RSD 1205.08 & 1205.11 FOR MARKINGS AT RAILROAD CROSSINGS

PAVEMENT MARKING DETAIL

TIP NO. R-2414B	SHEET NO. PMP-11
APPROVED: <i>Bob A. May</i>	
DATE: <i>10/18/11</i>	
SEAL	
	



-Y3- STA. 10+00.000
TIE TO EXISTING MARKINGS

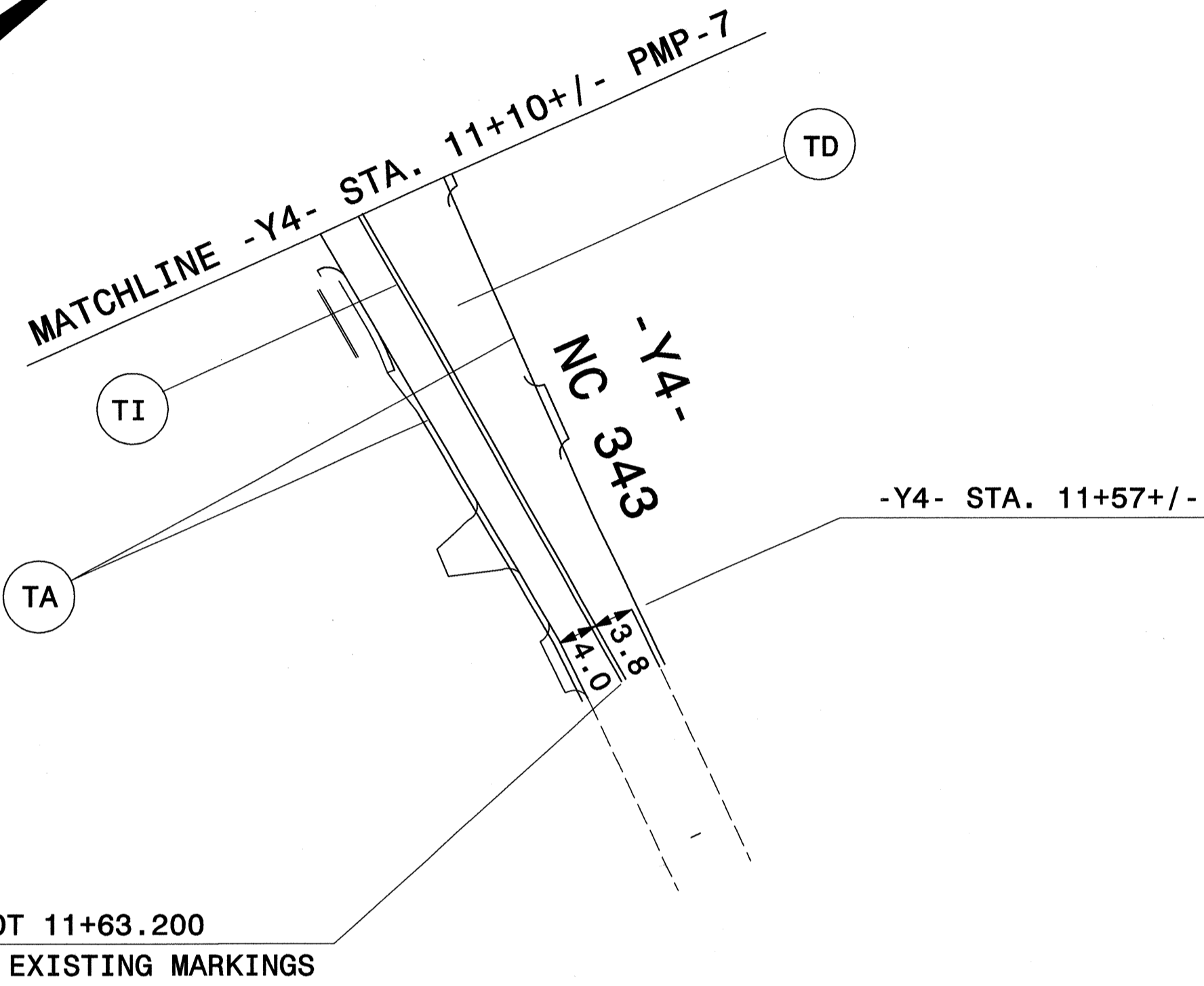
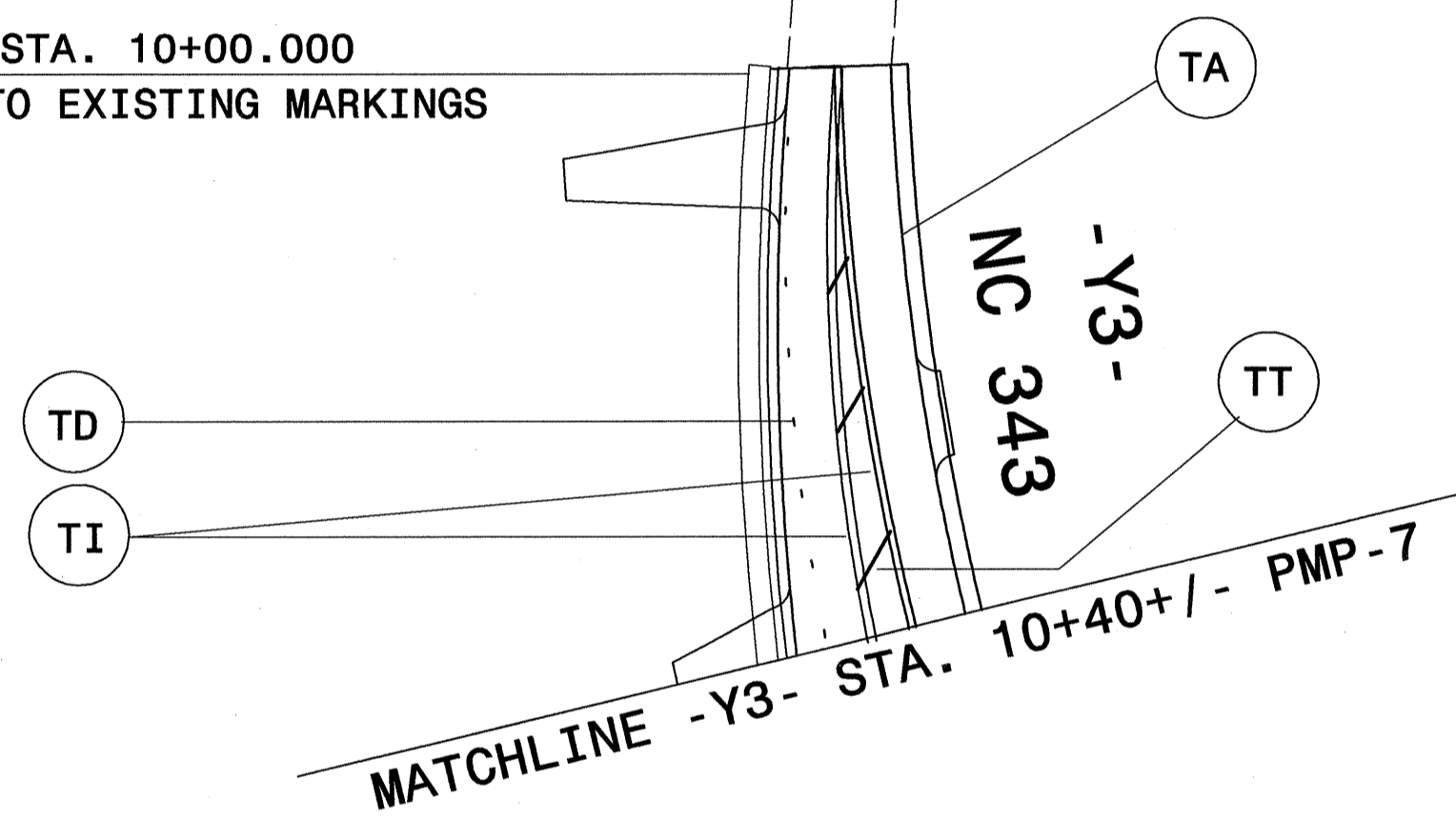

- SEE PMP-2 FOR PAVEMENT MARKING SCHEDULE

PAVEMENT MARKING DETAIL

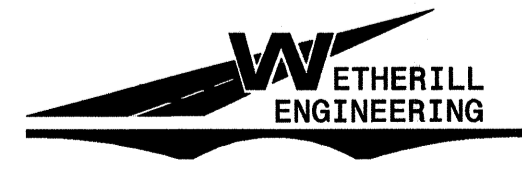
WETHERILL ENGINEERING
 559 Jones Franklin Rd. Suite 164
 Raleigh, N.C. 27606
 Bus: 919 851 8077
 Fax: 919 851 8107
 License: F-0377

TRANSPORTATION PLANNING/DESIGN - BRIDGE/STRUCTURE DESIGN
 CIVIL/SITE DESIGN - GIS/GPS - CONSTRUCTION OBSERVATION

10/18/2011 4:14:20 PM P:\R-2414B\TrafficControl\TCPV\2414b_pm_pshll.dgn