

09/08/99

See Sheet 1-A For Index of Sheets
See Sheet 1-B For Conventional Symbols
See Sheet 1-C For Survey Control Sheet

STATE OF NORTH CAROLINA
DIVISION OF HIGHWAYS

CABARRUS COUNTY

LOCATION: BRIDGE NO. 30 OVER IRISH BUFFALO CREEK ON
SR 1778 (ORPHANAGE ROAD)

TYPE OF WORK: GRADING, DRAINAGE, PAVING, AND STRUCTURE

STATE	STATE PROJECT REFERENCE NO.	SHEET NO.	TOTAL SHEETS
N.C.	B-4050	1	
STATE PROJ. NO.	F.A. PROJ. NO.	DESCRIPTION	
33416.1.1	BRSTP-1778(1)	P.E.	
33416.2.1	BRSTP-1778(1)	R/W & UTILITIES	
33416.3.1	BRSTP-1778(1)	CONST.	

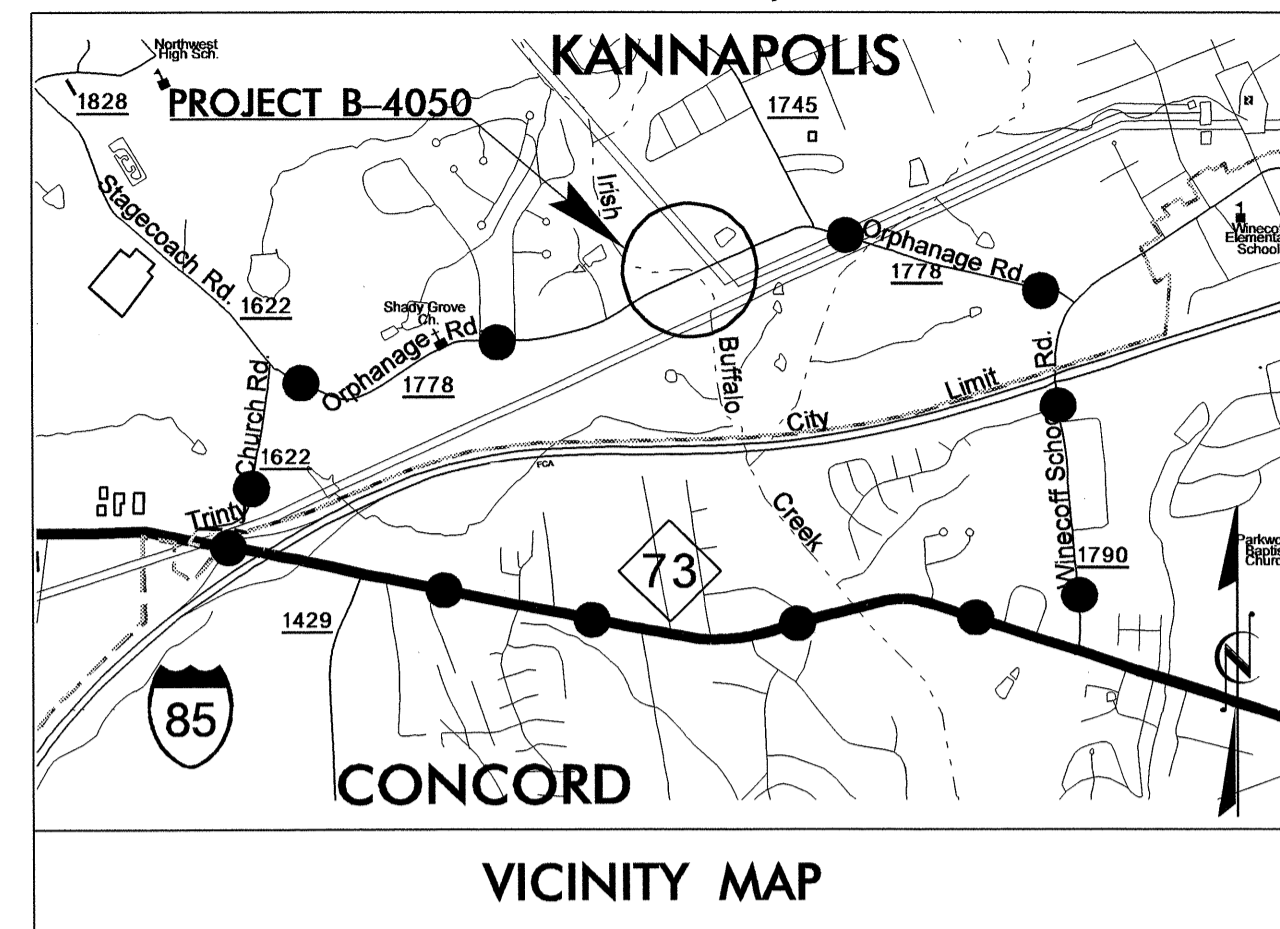

●●● DETOUR ROUTE

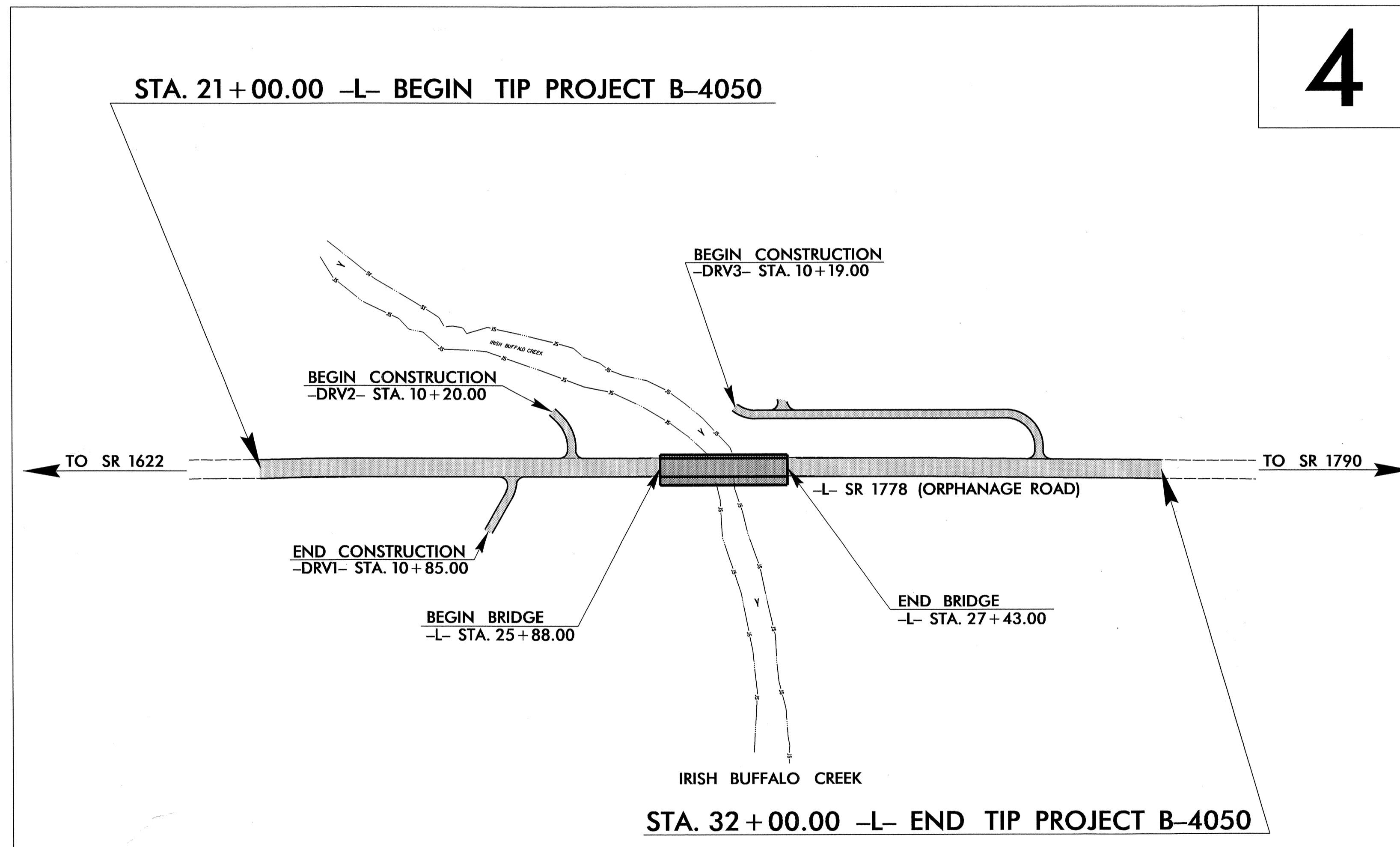

4

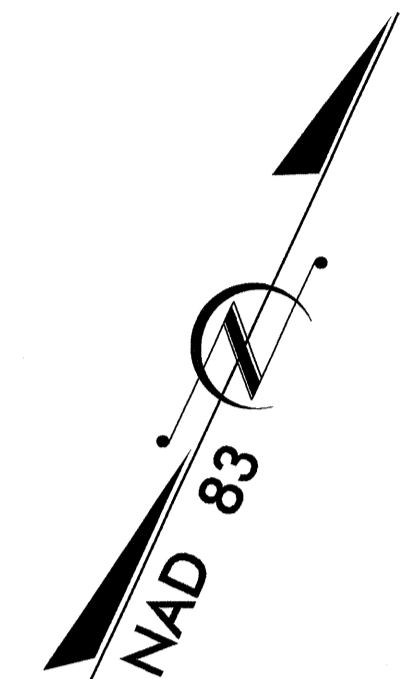

TIP PROJECT: B-4050

CONTRACT: C202774

DESIGN EXCEPTION REQUIRED FOR SAG VERTICAL CURVES AND STOPPING SIGHT DISTANCES.

GRAPHIC SCALES

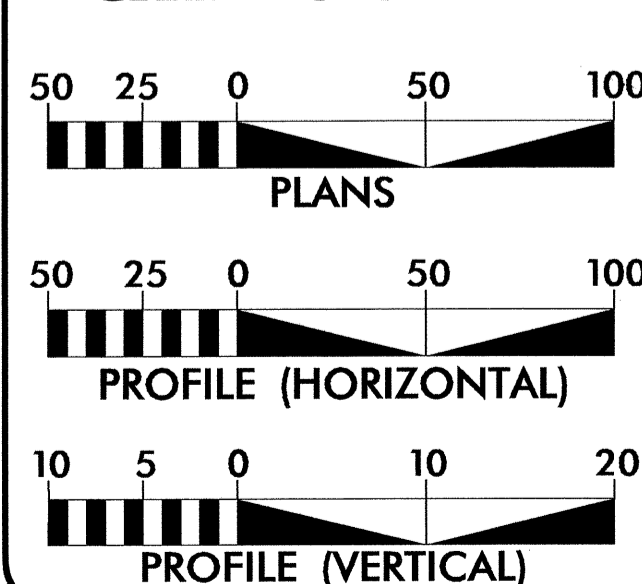

DESIGN DATA

ADT 2012 = 9735
 ADT 2025 = 12900
 DHV = 10 %
 D = 55 %
 T = 4 % *
 V = 50 MPH
 * TTST 1% DUAL 3%
 FUNC CLASS = URBAN
 COLLECTOR
 "SUB-REGIONAL TIER"

PROJECT LENGTH

LENGTH ROADWAY TIP PROJECT B-4050 = 0.179 MILES
 LENGTH STRUCTURE TIP PROJECT B-4050 = 0.029 MILES
 TOTAL LENGTH OF TIP PROJECT B-4050 = 0.208 MILES

Prepared in the Office of:
DIVISION OF HIGHWAYS
 1000 Birch Ridge Dr., Raleigh NC, 27610

2012 STANDARD SPECIFICATIONS

RIGHT OF WAY DATE:
 FEBRUARY 9, 2011

LETTING DATE:
 FEBRUARY 21, 2012

JAMES A. SPEER, PE
 PROJECT ENGINEER

DANIEL W. GARDNER, JR., PE
 PROJECT DESIGN ENGINEER

HYDRAULICS ENGINEER

David P. Bohm
 SIGNATURE: P.E.

ROADWAY DESIGN
 ENGINEER

Daniel W. Gardner, Jr.
 SIGNATURE: P.E. 11/30/11

DIVISION OF HIGHWAYS
 STATE OF NORTH CAROLINA

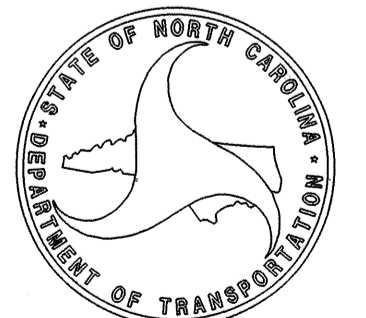

STATE HIGHWAY DESIGN ENGINEER P.E.

10-NOV-2011 14:02
 P:\P\04050\11\B-4050_rdy_tsh.dgn
 \$\$\$USERNAME\$\$\$

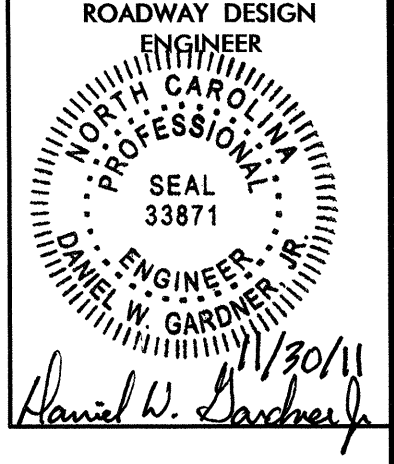

SHEET NUMBER	SHEET
1	TITLE SHEET
1-A	INDEX OF SHEETS, GENERAL NOTES, AND LIST OF STANDARD DRAWINGS
1-B	CONVENTIONAL PLAN SHEET SYMBOLS
1-C	SURVEY CONTROL SHEET
2 THRU 2-B	PAVEMENT SCHEDULE, TYPICAL SECTIONS, WEDGING DETAIL, AND GREENWAY DETAIL
3	SUMMARY OF QUANTITIES
3-A	DRAINAGE SUMMARY, GUARDRAIL SUMMARY, EARTHWORK SUMMARY, PAVEMENT REMOVAL SUMMARY, SUMMARY OF BREAKING EXISTING ASPHALT PAVEMENT, SHOULDER BERM GUTTER SUMMARY, AND WOVEN WIRE FENCE SUMMARY
4	PLAN SHEET
5 THRU 6	PROFILE SHEETS
TMP-1 THRU TMP-3	TRANSPORTATION MANAGEMENT PLANS
EC-1 THRU EC-5	EROSION CONTROL PLANS
UC-1 THRU UC-2	UTILITY CONSTRUCTION PLANS
UD-1 THRU UD-2	UTILITIES BY OTHERS PLANS
X-1	CROSS-SECTION SUMMARY
X-2 THRU X-20	CROSS-SECTIONS
S-1 THRU S-27	STRUCTURE PLANS

INDEX OF SHEETS	SHEET
	TITLE SHEET
	INDEX OF SHEETS, GENERAL NOTES, AND LIST OF STANDARD DRAWINGS
	CONVENTIONAL PLAN SHEET SYMBOLS
	SURVEY CONTROL SHEET
	PAVEMENT SCHEDULE, TYPICAL SECTIONS, WEDGING DETAIL, AND GREENWAY DETAIL
	SUMMARY OF QUANTITIES
	DRAINAGE SUMMARY, GUARDRAIL SUMMARY, EARTHWORK SUMMARY, PAVEMENT REMOVAL SUMMARY, SUMMARY OF BREAKING EXISTING ASPHALT PAVEMENT, SHOULDER BERM GUTTER SUMMARY, AND WOVEN WIRE FENCE SUMMARY
	PLAN SHEET
	PROFILE SHEETS
	TRANSPORTATION MANAGEMENT PLANS
	EROSION CONTROL PLANS
	UTILITY CONSTRUCTION PLANS
	UTILITIES BY OTHERS PLANS
	CROSS-SECTION SUMMARY
	CROSS-SECTIONS
	STRUCTURE PLANS

GENERAL NOTES:

2012 SPECIFICATIONS
EFFECTIVE: 01-17-12
REVISED: 11/01/11

GRADING AND SURFACING OR RESURFACING AND WIDENING:

THE GRADE LINES SHOWN DENOTE THE FINISHED ELEVATION OF THE PROPOSED SURFACING AT GRADE POINTS SHOWN ON THE TYPICAL SECTIONS. WHERE NO GRADE LINES ARE SHOWN, THE PROFILES SHOWN DENOTE THE TOP ELEVATION OF THE EXISTING PAVEMENT ALONG THE CENTER LINE OF SURVEY ON WHICH THE PROPOSED RESURFACING WILL BE PLACED. GRADE LINES MAY BE ADJUSTED BY THE ENGINEER IN ORDER TO SECURE A PROPER TIE-IN.

CLEARING:

CLEARING ON THIS PROJECT SHALL BE PERFORMED TO THE LIMITS ESTABLISHED BY METHOD III.

SUPERELEVATION:

ALL CURVES ON THIS PROJECT SHALL BE SUPERELEVATED IN ACCORDANCE WITH STD. NO. 225.04 USING THE RATE OF SUPERELEVATION AND RUNOFF SHOWN ON THE PLANS. SUPERELEVATION IS TO BE REVOLVED ABOUT THE GRADE POINTS SHOWN ON THE TYPICAL SECTIONS.

SHOULDER CONSTRUCTION:

ASPHALT, EARTH, AND CONCRETE SHOULDER CONSTRUCTION ON THE HIGH SIDE OF SUPERELEVATED CURVES SHALL BE IN ACCORDANCE WITH STD. NO. 560.01.

SIDE ROADS:

THE CONTRACTOR WILL BE REQUIRED TO DO ALL NECESSARY WORK TO PROVIDE SUITABLE CONNECTIONS WITH ALL ROADS, STREETS, AND DRIVES ENTERING THIS PROJECT. THIS WORK WILL BE PAID FOR AT THE CONTRACT UNIT PRICE FOR THE PARTICULAR ITEMS INVOLVED.

UNDERDRAINS:

UNDERDRAINS SHALL BE CONSTRUCTED IN ACCORDANCE WITH STD. NO. 815.03 AT LOCATIONS DIRECTED BY THE ENGINEER.

GUARDRAIL:

THE GUARDRAIL LOCATIONS SHOWN ON THE PLANS MAY BE ADJUSTED DURING CONSTRUCTION AS DIRECTED BY THE ENGINEER. THE CONTRACTOR SHOULD CONSULT WITH THE ENGINEER PRIOR TO ORDERING GUARDRAIL MATERIAL.

TEMPORARY SHORING:

SHORING REQUIRED FOR THE MAINTENANCE OF TRAFFIC WILL BE PAID FOR AS "EXTRA WORK" IN ACCORDANCE WITH SECTION 104-7.

SUBSURFACE PLANS:

NO SUBSURFACE PLANS ARE AVAILABLE ON THIS PROJECT. THE CONTRACTOR SHOULD MAKE HIS OWN INVESTIGATION AS TO THE SUBSURFACE CONDITIONS.

END BENTS:

THE ENGINEER SHALL CHECK THE STRUCTURE END BENT PLANS, DETAILS, AND CROSS-SECTION PRIOR TO SETTING OF THE SLOPE STAKES FOR THE EMBANKMENT OR EXCAVATION APPROACHING A BRIDGE.

UTILITIES:

UTILITY OWNERS ON THIS PROJECT ARE

DUKE ENERGY - DISTRIBUTION, DUKE ENERGY - TRANSMISSION.

WIND STREAM COMMUNICATION - TELEPHONE, TIME WARNER - CABLE.

PSNC ENERGY - GAS, CITY OF KANNAPOLIS - WATER AND SANITARY SEWER

ANY RELOCATION OF EXISTING UTILITIES WILL BE ACCOMPLISHED BY OTHERS, EXCEPT AS SHOWN ON THE PLANS.

RIGHT-OF-WAY MARKERS:

ALL RIGHT-OF-WAY MARKERS ON THIS PROJECT SHALL BE PLACED BY OTHERS.

2012 ROADWAY ENGLISH STANDARD DRAWINGS

The following Roadway Standards as appear in "Roadway Standard Drawings" Highway Design Branch - N. C. Department of Transportation - Raleigh, N. C., Dated January, 2012 are applicable to this project and by reference hereby are considered a part of these plans:

STD. NO.	TITLE
DIVISION 2 - EARTHWORK	
200.03	Method of Clearing - Method III
225.02	Guide for Grading Subgrade - Secondary and Local
225.04	Method of Obtaining Superelevation - Two Lane Pavement
DIVISION 3 - PIPE CULVERTS	
300.01	Method of Pipe Installation
310.10	Driveway Pipe Construction
DIVISION 4 - MAJOR STRUCTURES	
422.11	Reinforced Bridge Approach Fills - Sub Regional Tier
DIVISION 5 - SUBGRADE, BASES AND SHOULDERS	
560.01	Method of Shoulder Construction - High Side of Superelevated Curve - Method I
DIVISION 8 - INCIDENTALS	
815.03	Pipe Underdrain and Blind Drain
838.01	Concrete Endwall for Single and Double Pipe Culverts - 15" thru 48" Pipe 90 Skew
838.11	Brick Endwall for Single and Double Pipe Culverts - 15" thru 48" Pipe 90 Skew
838.80	Precast Endwalls - 12" thru 72" Pipe 90 Skew
840.00	Concrete Base Pad for Drainage Structures
840.25	Anchorage for Frames - Brick or Concrete or Precast
840.29	Frames and Narrow Slot Flat Grates
840.35	Traffic Bearing Grated Drop Inlet - for Cast Iron Double Frame and Grates
840.46	Traffic Bearing Precast Drainage Structure
840.66	Drainage Structure Steps
846.01	Concrete Curb, Gutter and Curb & Gutter
862.01	Guardrail Placement
862.02	Guardrail Installation
862.03	Structure Anchor Units
866.02	Woven Wire Fence - with Wood Post
876.02	Guide for Rip Rap at Pipe Outlets

8/17/99















30-NOV-2011 13:35
A:\Roadway\Proj\B4050_rdy_sum.dgn
\$\$\$\$\$

Note: Not to Scale











*S.U.E. = Subsurface Utility Engineering

CONVENTIONAL PLAN SHEET SYMBOLS











BOUNDARIES AND PROPERTY:

State Line	-----
County Line	-----
Township Line	-----
City Line	-----
Reservation Line	-----
Property Line	-----
Existing Iron Pin	----- 
Property Corner	----- 
Property Monument	----- 
Parcel/Sequence Number	----- 
Existing Fence Line	----- 
Proposed Woven Wire Fence	----- 
Proposed Chain Link Fence	----- 
Proposed Barbed Wire Fence	----- 
Existing Wetland Boundary	----- 
Proposed Wetland Boundary	----- 
Existing Endangered Animal Boundary	----- 
Existing Endangered Plant Boundary	----- 
Known Soil Contamination: Area or Site	----- 
Potential Soil Contamination: Area or Site	----- 





BUILDINGS AND OTHER CULTURE:

Gas Pump Vent or U/G Tank Cap	----- 
Sign	----- 
Well	----- 
Small Mine	----- 
Foundation	----- 
Area Outline	----- 
Cemetery	----- 
Building	----- 
School	----- 
Church	----- 
Dam	----- 





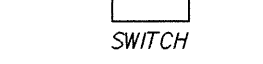



HYDROLOGY:

Stream or Body of Water	-----
Hydro, Pool or Reservoir	----- 
Jurisdictional Stream	----- 
Buffer Zone 1	----- 
Buffer Zone 2	----- 
Flow Arrow	----- 
Disappearing Stream	----- 
Spring	----- 
Wetland	----- 
Proposed Lateral, Tail, Head Ditch	----- 
False Sump	----- 

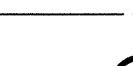





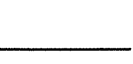
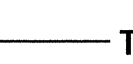
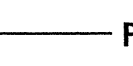
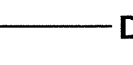
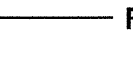
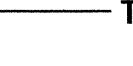
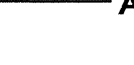

RAILROADS:

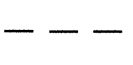
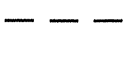
Standard Gauge	----- 
RR Signal Milepost	----- 
Switch	----- 
RR Abandoned	----- 
RR Dismantled	----- 





RIGHT OF WAY:

Baseline Control Point	----- 
Existing Right of Way Marker	----- 
Existing Right of Way Line	----- 
Proposed Right of Way Line	----- 
Proposed Right of Way Line with Iron Pin and Cap Marker	----- 
Proposed Right of Way Line with Concrete or Granite Marker	----- 
Existing Control of Access	----- 
Proposed Control of Access	----- 
Existing Easement Line	----- 
Proposed Temporary Construction Easement	----- 
Proposed Temporary Drainage Easement	----- 
Proposed Permanent Drainage Easement	----- 
Proposed Permanent Drainage / Utility Easement	----- 
Proposed Permanent Utility Easement	----- 
Proposed Temporary Utility Easement	----- 
Proposed Aerial Utility Easement	----- 

ROADS AND RELATED FEATURES:



Existing Edge of Pavement	-----
Existing Curb	-----
Proposed Slope Stakes Cut	----- 
Proposed Slope Stakes Fill	----- 
Proposed Curb Ramp	----- 
Existing Metal Guardrail	----- 
Proposed Guardrail	----- 
Existing Cable Guiderail	----- 
Proposed Cable Guiderail	----- 
Equality Symbol	----- 
Pavement Removal	----- 

VEGETATION:

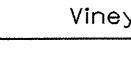



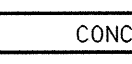
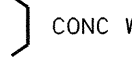
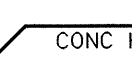
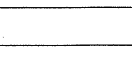
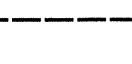
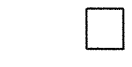
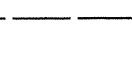
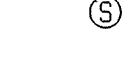



Single Tree	----- 
Single Shrub	----- 
Hedge	----- 
Woods Line	----- 

Orchard	----- 
Vineyard	----- 

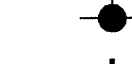

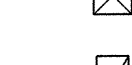

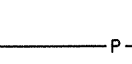
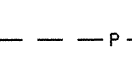



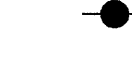

EXISTING STRUCTURES:

MAJOR:	
Bridge, Tunnel or Box Culvert	----- 
Bridge Wing Wall, Head Wall and End Wall	----- 
MINOR:	
Head and End Wall	----- 
Pipe Culvert	----- 
Footbridge	----- 
Drainage Box: Catch Basin, DI or JB	----- 
Paved Ditch Gutter	----- 
Storm Sewer Manhole	----- 
Storm Sewer	----- 



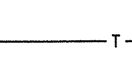

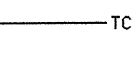
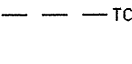
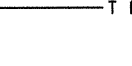

UTILITIES:

POWER:	
Existing Power Pole	----- 
Proposed Power Pole	----- 
Existing Joint Use Pole	----- 
Proposed Joint Use Pole	----- 
Power Manhole	----- 
Power Line Tower	----- 
Power Transformer	----- 
U/G Power Cable Hand Hole	----- 
H-Frame Pole	----- 
Recorded U/G Power Line	----- 
Designated U/G Power Line (S.U.E.*)	----- 









TELEPHONE:

Existing Telephone Pole	----- 
Proposed Telephone Pole	----- 
Telephone Manhole	----- 
Telephone Booth	----- 
Telephone Pedestal	----- 
Telephone Cell Tower	----- 
U/G Telephone Cable Hand Hole	----- 
Recorded U/G Telephone Cable	----- 
Designated U/G Telephone Cable (S.U.E.*)	----- 
Recorded U/G Telephone Conduit	----- 
Designated U/G Telephone Conduit (S.U.E.*)	----- 
Recorded U/G Fiber Optics Cable	----- 
Designated U/G Fiber Optics Cable (S.U.E.*)	----- 





WATER:

Water Manhole	----- 
Water Meter	----- 
Water Valve	----- 
Water Hydrant	----- 
Recorded U/G Water Line	----- 
Designated U/G Water Line (S.U.E.*)	----- 
Above Ground Water Line	----- 







TV:

TV Satellite Dish	----- 
TV Pedestal	----- 
TV Tower	----- 
U/G TV Cable Hand Hole	----- 
Recorded U/G TV Cable	----- 
Designated U/G TV Cable (S.U.E.*)	----- 
Recorded U/G Fiber Optic Cable	----- 
Designated U/G Fiber Optic Cable (S.U.E.*)	----- 













GAS:

Gas Valve	----- 
Gas Meter	----- 
Recorded U/G Gas Line	----- 
Designated U/G Gas Line (S.U.E.*)	----- 
Above Ground Gas Line	----- 

SANITARY SEWER:

Sanitary Sewer Manhole	----- 
Sanitary Sewer Cleanout	----- 
U/G Sanitary Sewer Line	----- 
Above Ground Sanitary Sewer	----- 
Recorded SS Forced Main Line	----- 
Designated SS Forced Main Line (S.U.E.*)	----- 

MISCELLANEOUS:

Utility Pole	----- 
Utility Pole with Base	----- 
Utility Located Object	----- 
Utility Traffic Signal Box	----- 
Utility Unknown U/G Line	----- 
U/G Tank; Water, Gas, Oil	----- 
Underground Storage Tank, Approx. Loc.	----- 
A/G Tank; Water, Gas, Oil	----- 
Geoenvironmental Boring	----- 
U/G Test Hole (S.U.E.*)	----- 
Abandoned According to Utility Records	----- 
End of Information	----- 

SURVEY CONTROL SHEET

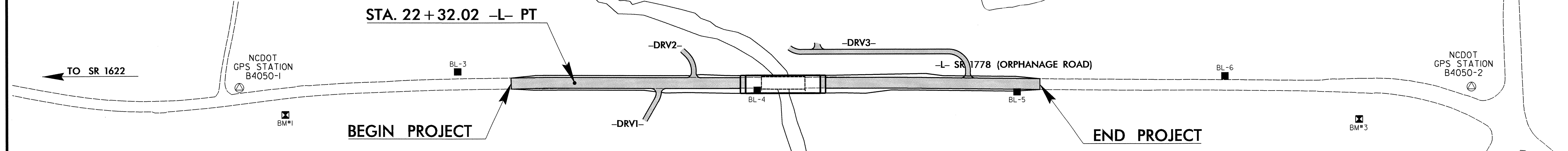
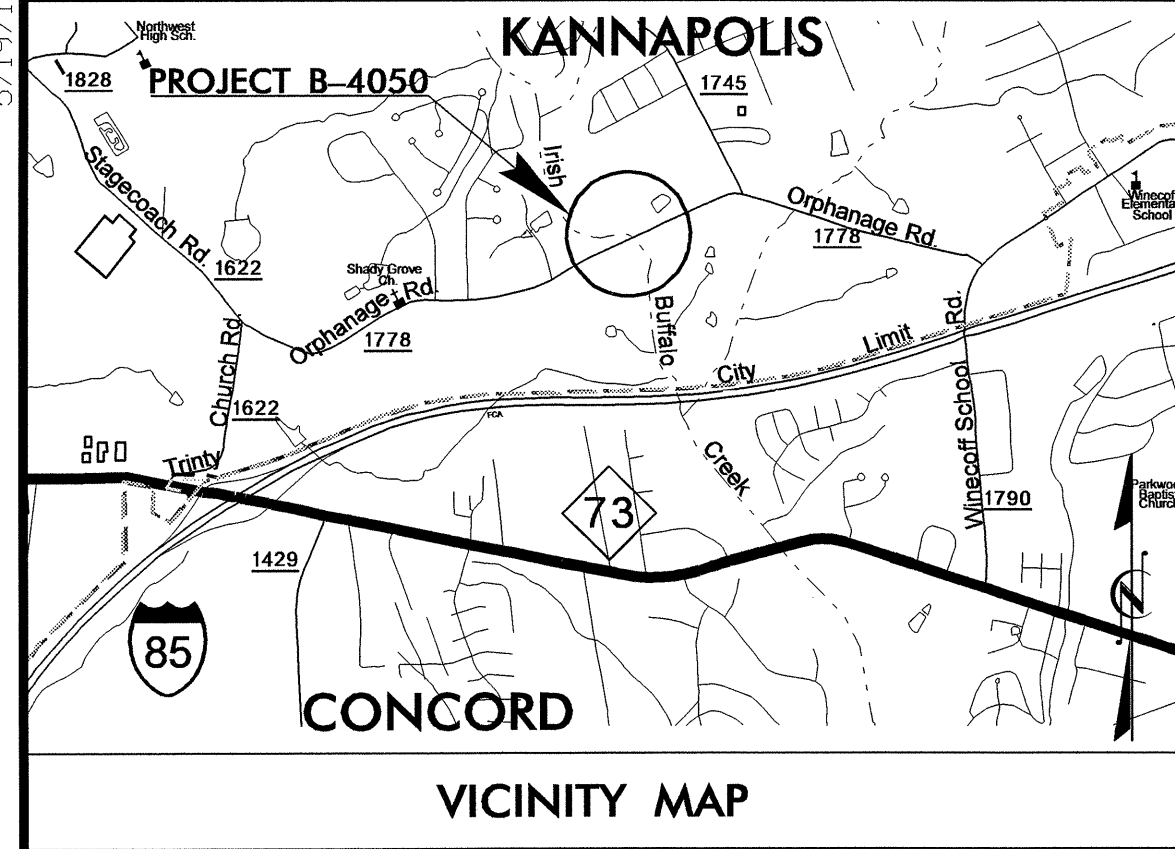

DATUM DESCRIPTION

THE LOCALIZED COORDINATE SYSTEM DEVELOPED FOR THIS PROJECT IS BASED ON THE STATE PLANE COORDINATES ESTABLISHED BY NCDOT FOR MONUMENT "B4050-1" WITH NAD 83 STATE PLANE GRID COORDINATES OF
 NORTHING: 620333.596(ft) EASTING: 1510364.611(ft)
 ELEVATION: 678.38(ft)
 THE AVERAGE COMBINED GRID FACTOR USED ON THIS PROJECT (GROUND TO GRID) IS: 0.99985100
 THE N.C. LAMBERT GRID BEARING AND LOCALIZED HORIZONTAL GROUND DISTANCE FROM "B4050-1" TO -L- STATION 22+32.02 IS
 N 64°33'02.0" E 697.185
 ALL LINEAR DIMENSIONS ARE LOCALIZED HORIZONTAL DISTANCES
 VERTICAL DATUM USED IS NAVD 88

 BM1 ELEVATION = 678.31
 N 620322 E 1510475
 L STATION 16+25 45 RIGHT
 NCSHC 7JS14

 BM2 ELEVATION = 625.94
 N 620993 E 1511292
 L STATION 26+53 203 LEFT
 RR SPIKE IN 18" SWEETGUM

 BM3 ELEVATION = 661.35
 N 621243 E 1512510
 L STATION 38+64 69 RIGHT
 RR SPIKE IN 12' CEDAR

BL	POINT	DESC.	NORTH	EAST	ELEVATION	L STATION	OFFSET
1		B4050-1	620333.5960	1510364.6110	678.38	15+36.65	22.59 LT
3		BL-3	620552.5150	1510763.5950	655.28	19+89.48	25.94 LT
4		BL-4	620778.0280	1511345.3890	627.17	26+11.67	14.58 RT
5		BL-5	620998.9780	1511838.9910	632.35	31+52.64	16.63 RT
6		BL-6	621208.5580	1512218.7990	659.15	35+84.95	19.27 LT
2		B4050-2	621401.6020	1512694.4510	663.03	40+86.44	44.95 LT

		L	
TYPE	STATION	NORTH	EAST
POT	10+00.00	620119.4270	1509880.8900
PC	11+59.65	620158.1130	1510035.7780
PRC	14+90.07	620289.3884	1510337.3549
PT	17+82.07	620435.7793	1510589.8622
PC	18+27.58	620456.5708	1510630.3477
PT	22+32.02	620633.1864	1510994.1441
PC	28+56.79	620893.3492	1511562.1730
PT	29+64.25	620937.5706	1511660.1106
PC	32+93.65	621071.5114	1511961.0520
PT	33+98.19	621114.2450	1512056.4560
PC	38+66.00	621306.4939	1512482.9383
PT	42+61.01	621336.9732	1512868.9670
POT	45+61.40	621258.0310	1513158.8060

		DRV1	
TYPE	STATION	NORTH	EAST
POT	10+00.00	620706.4681	1511154.1444
PC	10+11.45	620696.0615	1511158.9107
PT	10+37.19	620670.9785	1511163.2699
POT	11+10.61	620597.8265	1511157.0111

		DRV2	
TYPE	STATION	NORTH	EAST
POT	10+00.00	620795.3499	1511150.8960
PC	10+31.85	620784.6534	1511180.8952
PT	10+71.79	620758.3782	1511209.5616
POT	10+95.91	620736.4497	1511219.6051

		DRV3	
TYPE	STATION	NORTH	EAST
POT	10+00.00	620892.2832	1511352.2022
PC	10+15.65	620887.3278	1511367.0464
PT	10+45.72	620888.9025	1511396.3687
PC	13+51.80	621016.3590	1511674.6521
PT	14+15.06	620996.2567	1511727.8525
POT	14+41.13	620972.4387	1511738.4532

ROW MARKER IRON PIN AND CAP				
ALIGN	STATION	OFFSET	NORTH	EAST
L	21+00.00	20.49	620558.8287	1510883.3323
L	21+00.00	-19.51	620594.9478	1510866.1440
L	21+00.00	40.00	620541.2161	1510891.7137
L	21+00.00	-40.00	620613.4538	1510857.3375
L	22+32.02	-40.00	620669.5534	1510977.4877
L	22+32.02	50.00	620587.7276	1511014.9647
L	28+56.79	-40.00	620929.7162	1511545.5165
L	28+56.79	50.00	620847.8904	1511582.9935
L	29+64.25	-40.00	620974.1145	1511643.8459
L	29+64.25	50.00	620891.8906	1511680.4415
L	31+00.00	40.00	620956.2257	1511800.3979
L	31+00.00	50.00	620947.0897	1511804.4640
L	32+00.00	-40.00	621069.9753	1511859.2283
L	32+00.00	-20.00	621051.7034	1511867.3606
L	32+00.00	40.00	620996.8875	1511891.7577
L	32+00.00	20.00	621015.1595	1511883.6253

ROW MARKER PERMANENT EASEMENT				
ALIGN	STATION	OFFSET	NORTH	EAST
L	25+00.00	-40.00	620781.1450	1511221.1321
L	25+00.00	-55.00	620794.7826	1511214.8859
L	25+41.00	50.00	620716.3920	1511295.8854
L	25+41.00	66.00	620701.8452	1511302.5480
L	25+75.00	-60.00	620830.5594	1511280.9921
L	25+83.00	66.00	620719.3345	1511340.7334
L	25+83.00	50.00	620733.8813	1511334.0708
L	26+95.00	-95.00	620912.3499	1511375.5188
L	27+44.00	50.00	620800.9236	1511480.4481
L	27+44.00	66.00	620786.3768	1511487.1107
L	27+86.00	66.00	620803.8660	1511525.2961
L	27+86.00	50.00	620818.4129	1511518.6335
L	28+00.00	-105.00	620965.1649	1511466.8182
L	30+25.00	-105.00	621058.2011	1511672.9184
L	30+55.00	-85.00	621052.1277	1511708.4587
L	30+90.00	-40.00	621025.2474	1511758.7324

NOTES:

- THE CONTROL DATA FOR THIS PROJECT CAN BE FOUND ELECTRONICALLY BY SELECTING PROJECT CONTROL DATA AT: [HTTP://WWW.NCDOT.ORG/DOH/PRECONSTRUCT/HIGHWAY/LOCATION/PROJECT/](http://www.ncdot.org/DOH/PRECONSTRUCT/HIGHWAY/LOCATION/PROJECT/)
 THE FILES TO BE FOUND ARE AS FOLLOWS:
B4050_LS_CONTROL_081107.TXT
 SITE CALIBRATION INFORMATION HAS NOT BEEN PROVIDED FOR THIS PROJECT. IF FURTHER INFORMATION IS NEEDED, PLEASE CONTACT THE LOCATION AND SURVEYS UNIT.
- ⊙ INDICATES GEODETIC CONTROL MONUMENTS USED OR SET FOR HORIZONTAL PROJECT CONTROL BY THE NCDOT LOCATION AND SURVEYS UNIT.
 - INDICATES MONUMENTS USED OR SET FOR HORIZONTAL PROJECT CONTROL BY THE NCDOT LOCATION AND SURVEYS UNIT.
 - ⊠ INDICATES BENCHMARKS USED OR SET FOR VERTICAL PROJECT CONTROL BY THE NCDOT LOCATION AND SURVEYS UNIT.
- PROJECT CONTROL ESTABLISHED USING GLOBAL POSITIONING SYSTEM.
 NETWORK ESTABLISHED FROM NGS ONLINE POSITIONING SERVICE (OPUS)

NOTE: DRAWING NOT TO SCALE

10-NOV-2011 14:02 N:\b4050_1s_1c.dgn
 4:44:44 NCSHC 7JS14

8/17/99

PROJECT REFERENCE NO. B-4050	SHEET NO. 2
RW SHEET NO.	
ROADWAY DESIGN ENGINEER NORTH CAROLINA PROFESSIONAL SEAL 33871 DANIEL W. GARDNER	PAVEMENT DESIGN ENGINEER NORTH CAROLINA PROFESSIONAL SEAL 22898 CLARK S. MORRISON

PAVEMENT SCHEDULE	
C1	PROP. APPROX. 1½" ASPHALT CONCRETE SURFACE COURSE, TYPE S9.5B, AT AN AVERAGE RATE OF 168 LBS. PER SQ. YD.
C2	PROP. APPROX. 3" ASPHALT CONCRETE SURFACE COURSE, TYPE S9.5B, AT AN AVERAGE RATE OF 168 LBS. PER SQ. YD. IN EACH OF TWO LAYERS.
C3	PROP. VAR. DEPTH ASPHALT CONCRETE SURFACE COURSE, TYPE S9.5B, AT AN AVERAGE RATE OF 112 LBS. PER SQ. YD. PER 1" DEPTH. TO BE PLACED IN LAYERS NOT TO EXCEED 2" IN DEPTH.
D1	PROP. APPROX. 2½" ASPHALT CONCRETE INTERMEDIATE COURSE, TYPE I19.0B AT AN AVERAGE RATE OF 285 LBS. PER SQ. YD.
D2	PROP. VAR. DEPTH ASPHALT CONCRETE INTERMEDIATE COURSE, TYPE I19.0B AT AN AVERAGE RATE OF 114 LBS. PER SQ. YD. PER 1" DEPTH TO BE PLACED IN LAYERS NOT LESS THAN 2½" OR GREATER THAN 4" IN DEPTH.
E1	PROP. APPROX. 5½" ASPHALT CONCRETE BASE COURSE, TYPE B25.0B, AT AN AVERAGE RATE OF 627 LBS. PER SQ. YD.
E2	PROP. VAR. DEPTH ASPHALT CONCRETE BASE COURSE, TYPE B25.0B, AT AN AVERAGE RATE OF 114 LBS. PER SQ. YD. PER 1" DEPTH. TO BE PLACED IN LAYERS NOT LESS THAN 3" IN DEPTH OR GREATER THAN 5½" IN DEPTH.
J	6" AGGREGATE BASE COURSE.
T	EARTH MATERIAL.
U	EXISTING PAVEMENT.
V	MILLING EXISTING ASPHALT PAVEMENT, 0" TO 1½" DEPTH. (INCIDENTAL MILLING)
W	VARIABLE DEPTH ASPHALT PAVEMENT (SEE STANDARD WEDGING DETAIL).

NOTE: PAVEMENT EDGE SLOPES ARE 1:1 UNLESS SHOWN OTHERWISE.

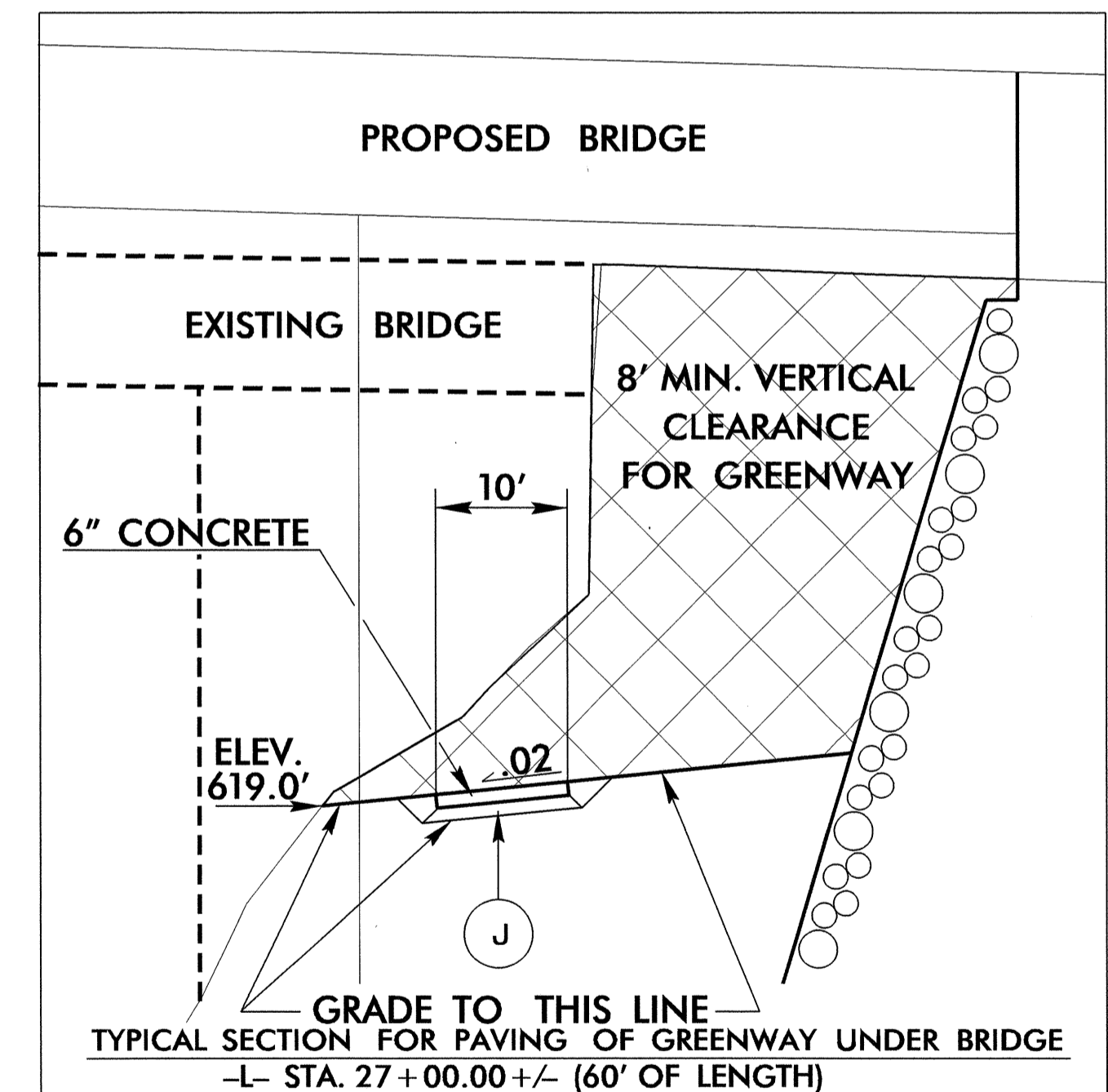
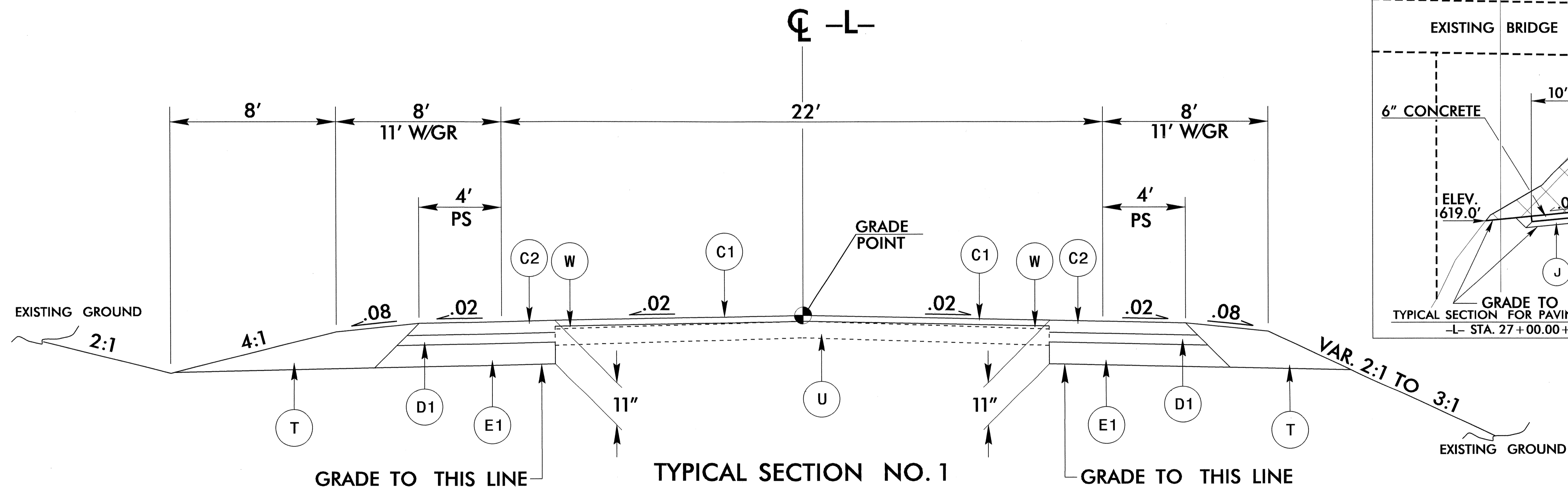
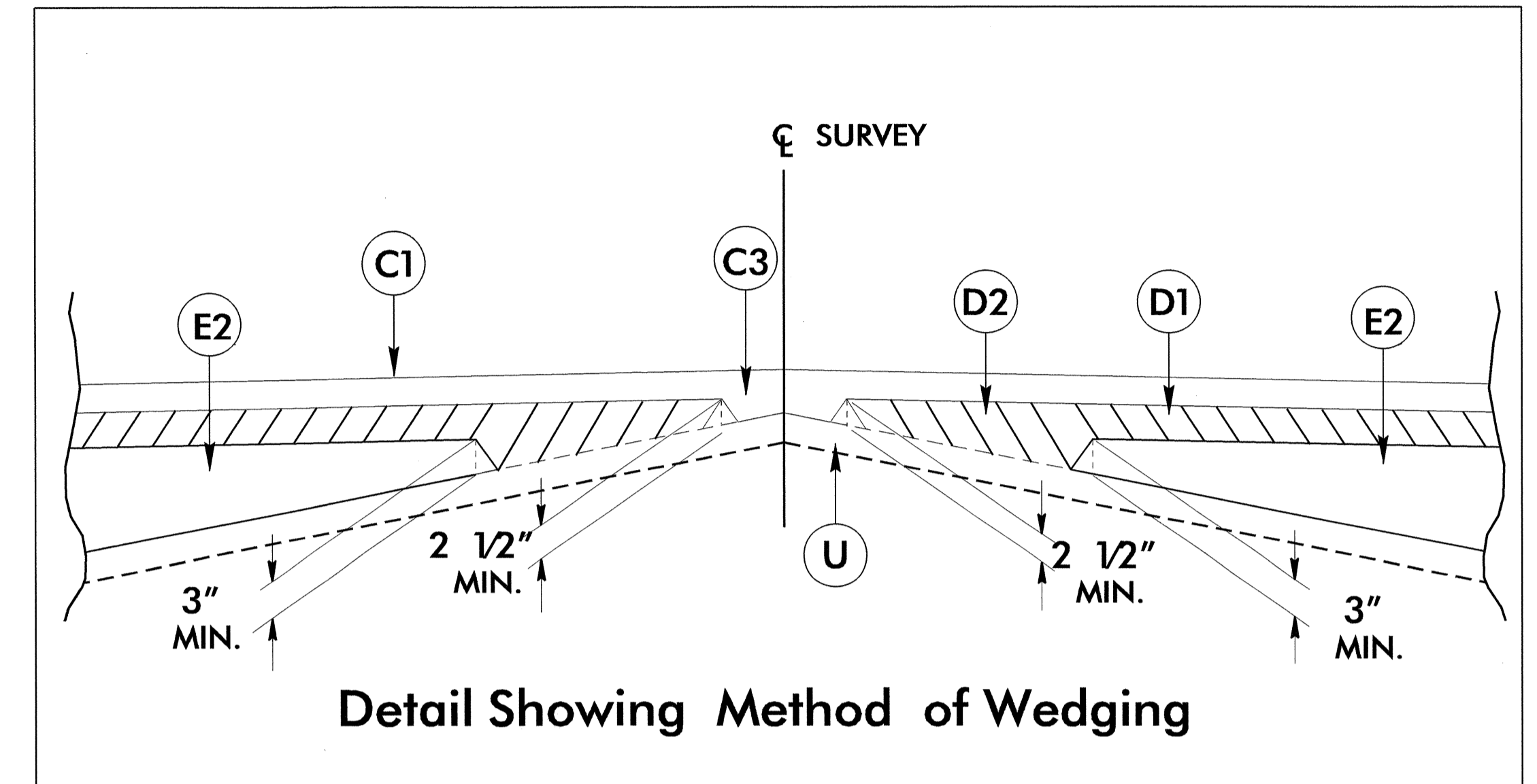

USE TYPICAL SECTION NO. 1

-L- STA. 21+00.00 TO STA. 22+75.00

NOTE: MILLING REQUIRED FOR PAVEMENT TIE-IN
-L- STA. 21+00.00 TO STA. 21+75.00

10: NOV-2011 14:02 448907581050_r.dwg - typ.dgn

8/17/99

PROJECT REFERENCE NO. B-4050	SHEET NO. 2-A
RW SHEET NO.	
ROADWAY DESIGN ENGINEER DANIEL W. GARDNER NORTH CAROLINA PROFESSIONAL ENGINEER SEAL 33871	PAVEMENT DESIGN ENGINEER CLARK S. MORRISON NORTH CAROLINA PROFESSIONAL ENGINEER SEAL 22898
PAVEMENT SCHEDULE	
C1	1½" TYPE S9.5B
C2	3" TYPE S9.5B
C3	VAR. DEPTH TYPE S9.5B
D1	2½" TYPE I19.0B
D2	VAR. DEPTH TYPE I19.0B
E1	5½" TYPE B25.0B
E2	VAR. DEPTH TYPE B25.0B
J	6" ABC
T	EARTH MATERIAL
U	EXISTING PAVEMENT
V	MILLING 0" TO 1½" DEPTH
W	WEDGING

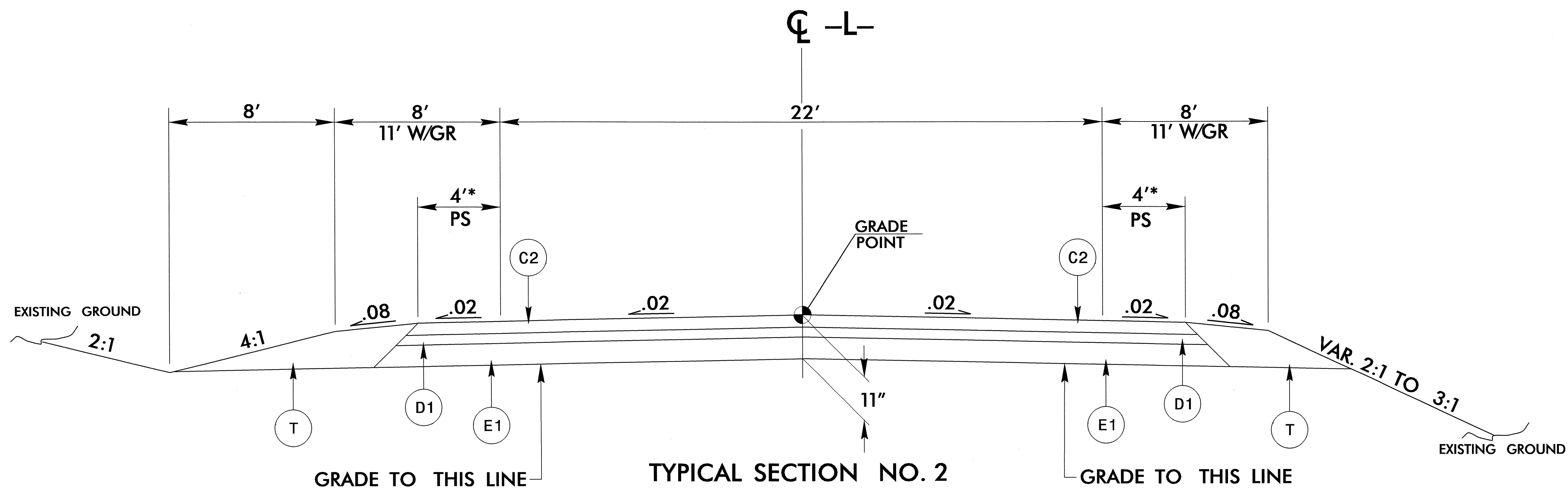

TYPICAL SECTION NO. 2

USE TYPICAL SECTION NO. 2

-L- STA. 22+75.00 TO STA. 25+88.00 (BEGIN BRIDGE)
-L- STA. 27+43.00 (END BRIDGE) TO STA. 32+00.00

*DENOTES EXTENDING THE PROPOSED PAVED SHOULDER WIDTH TO FACE OF PROPOSED GUARDRAIL. (SEE PLAN SHEET 4 FOR LIMITS)

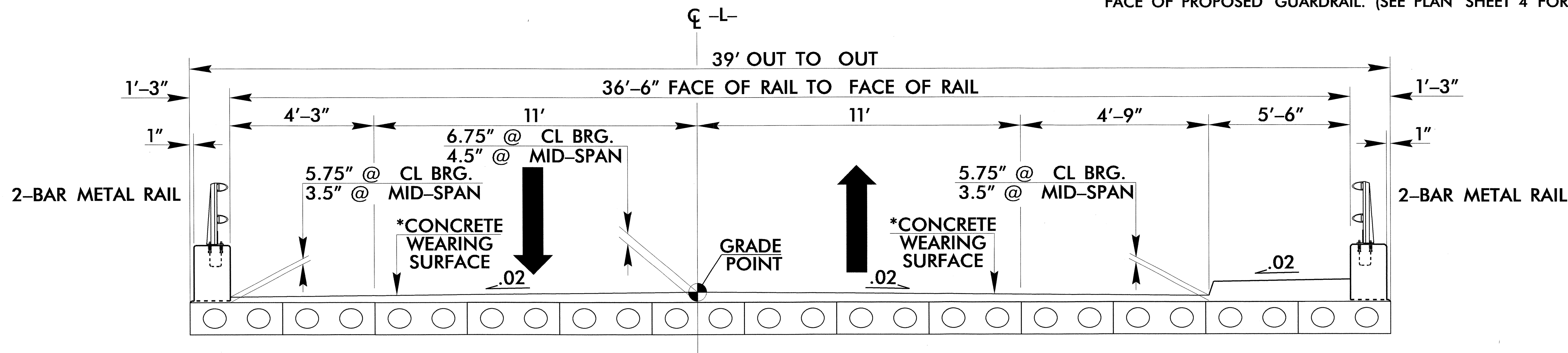

TYPICAL SECTION NO. 3

*STRUCTURE PAY ITEM

USE TYPICAL SECTION NO. 3

-L- STA. 25+88.00 (BEGIN BRIDGE) TO STA. 27+43.00 (END BRIDGE)

15-NOV-2011 14:01:33 B:\PROJECTS\B-4050.rdw-tytp.dgn

8/17/99

PROJECT REFERENCE NO. B-4050		SHEET NO. 2-B	
RW SHEET NO.			
ROADWAY DESIGN ENGINEER NORTH CAROLINA PROFESSIONAL SEAL 33871 DANIEL W. GARDNER 12/11		PAVEMENT DESIGN ENGINEER NORTH CAROLINA PROFESSIONAL SEAL 22896 CLARK S. MORRISON 12/11	
PAVEMENT SCHEDULE			
C1	1½" TYPE S9.5B		
C2	3" TYPE S9.5B		
C3	VAR. DEPTH TYPE S9.5B		
D1	2½" TYPE I19.0B		
D2	VAR. DEPTH TYPE I19.0B		
E1	5½" TYPE B25.0B		
E2	VAR. DEPTH TYPE B25.0B		
J	6" ABC		
T	EARTH MATERIAL		
U	EXISTING PAVEMENT		
V	MILLING 0" TO 1½" DEPTH		
W	WEDGING		

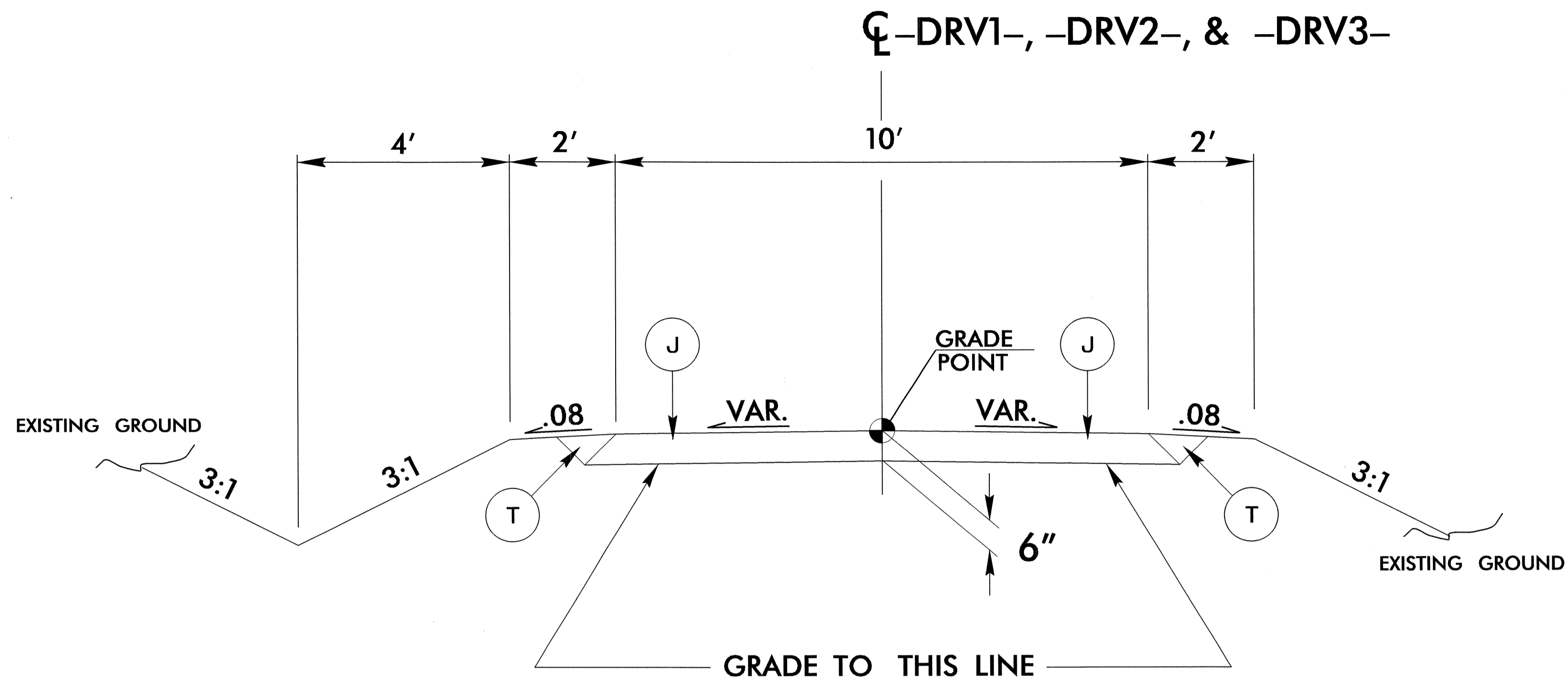

TYPICAL SECTION NO. 4

USE TYPICAL SECTION NO. 4

- DRV1- STA. 10+53.20 TO STA. 10+85.00
- DRV2- STA. 10+20.00 TO STA. 10+55.63
- DRV3- STA. 10+19.00 TO STA. 14+00.83

NOTE: PAVE -DRV1-, -DRV2-, AND -DRV3- TURNOUTS WITH C2, D1, AND E1 TO PROPOSED RW LIMITS.

15-NOV-2011 14:01
r:\projects\B-4050\15-4050_r.dwg - typ.dgn
33871

STATE OF NORTH CAROLINA
DIVISION OF HIGHWAYS
SUMMARY OF QUANTITIES

STATE OF NORTH CAROLINA
DIVISION OF HIGHWAYS
ROADWAY SUMMARY OF QUANTITIES FOR CONTRACT - C202774

ItemNumber	Sec #	Quantity	Unit	Description
0000100000-N	800	Lump Sum		MOBILIZATION
0000400000-N	801	Lump Sum		CONSTRUCTION SURVEYING
0030000000-N	SP	Lump Sum		BRIDGE APPROACH FILL - SUB REGIONAL TIER, STATION ***** (26+65.50 - L-)
0043000000-N	226	Lump Sum		GRADING
0050000000-E	226	1	ACR	SUPPLEMENTARY CLEARING & GRUB-BING
0057000000-E	226	250	CY	UNDERCUT EXCAVATION
0196000000-E	270	700	SY	GEOTEXTILE FOR SOIL STABILIZATION
0318000000-E	300	87	TON	FOUNDATION CONDITIONING MATERIAL, MINOR STRUCTURES
0320000000-E	300	317	SY	FOUNDATION CONDITIONING GEOTEXTILE
0335200000-E	305	124	LF	15" DRAINAGE PIPE
0335300000-E	305	24	LF	18" DRAINAGE PIPE
0335400000-E	305	28	LF	24" DRAINAGE PIPE
0396000000-E	310	68	LF	42" RC PIPE CULVERTS, CLASS III
0448200000-E	310	32	LF	15" RC PIPE CULVERTS, CLASS IV
0448300000-E	310	44	LF	18" RC PIPE CULVERTS, CLASS IV
0448700000-E	310	28	LF	42" RC PIPE CULVERTS, CLASS IV
0995000000-E	340	16	LF	PIPE REMOVAL
1099500000-E	505	175	CY	SHALLOW UNDERCUT
1099700000-E	505	350	TON	CLASS IV SUBGRADE STABILIZATION
1121000000-E	520	215	TON	AGGREGATE BASE COURSE
1220000000-E	545	150	TON	INCIDENTAL STONE BASE
1330000000-E	607	200	SY	INCIDENTAL MILLING
1489000000-E	610	1,100	TON	ASPHALT CONC BASE COURSE, TYPE B25.0B
1498000000-E	610	490	TON	ASPHALT CONC INTERMEDIATE COURSE, TYPE I119.0B
1519000000-E	610	620	TON	ASPHALT CONC SURFACE COURSE, TYPE S9.5B

ItemNumber	Sec #	Quantity	Unit	Description
1575000000-E	620	110	TON	ASPHALT BINDER FOR PLANT MIX
1693000000-E	654	50	TON	ASPHALT PLANT MIX, PAVEMENT REPAIR
2022000000-E	815	56	CY	SUBDRAIN EXCAVATION
2033000000-E	815	42	CY	SUBDRAIN FINE AGGREGATE
2044000000-E	815	250	LF	6" PERFORATED SUBDRAIN PIPE
2070000000-N	815	1	EA	SUBDRAIN PIPE OUTLET
2077000000-E	815	6	LF	6" OUTLET PIPE
2209000000-E	838	9	CY	ENDWALLS
2286000000-N	840	4	EA	MASONRY DRAINAGE STRUCTURES
2367000000-N	840	4	EA	FRAME WITH TWO GRATES, STD 840.29
2556000000-E	846	8	LF	SHOULDER BERM GUTTER
2612000000-E	848	70	SY	6" CONCRETE DRIVEWAY
2830000000-N	858	5	EA	ADJUSTMENT OF MANHOLES
2845000000-N	858	4	EA	ADJUSTMENT OF METER BOXES OR VALVE BOXES
3030000000-E	862	325	LF	STEEL BM GUARDRAIL
3150000000-N	862	10	EA	ADDITIONAL GUARDRAIL POSTS
3215000000-N	862	4	EA	GUARDRAIL ANCHOR UNITS, TYPE III
3270000000-N	SP	4	EA	GUARDRAIL ANCHOR UNITS, TYPE 350
3503000000-E	866	1,290	LF	WOVEN WIRE FENCE, 47" FABRIC
3509000000-E	866	60	EA	4" TIMBER FENCE POSTS, 7'-6" LONG
3515000000-E	866	70	EA	5" TIMBER FENCE POSTS, 8'-0" LONG
3566000000-E	867	55	LF	WOVEN WIRE FENCE RESET
3578000000-N	SP	2	EA	GENERIC FENCING ITEM REMOVE & RESET METAL GATE
3628000000-E	876	34	TON	RIP RAP, CLASS I
3649000000-E	876	15	TON	RIP RAP, CLASS B
3656000000-E	876	579	SY	GEOTEXTILE FOR DRAINAGE

ItemNumber	Sec #	Quantity	Unit	Description
3659000000-N	SP	2	EA	PREFORMED SCOUR HOLES WITH LEVEL SPREADER APRON
4400000000-E	1110	334	SF	WORK ZONE SIGNS (STATIONARY)
4410000000-E	1110	144	SF	WORK ZONE SIGNS (BARRICADE MOUNTED)
4445000000-E	1145	96	LF	BARRICADES (TYPE III)
5326200000-E	1510	584	LF	12" WATER LINE
5558000000-E	1515	2	EA	12" VALVE
5672000000-N	1515	2	EA	RELOCATE FIRE HYDRANT
5804000000-E	1530	560	LF	ABANDON 12" UTILITY PIPE
5871700000-E	1550	38	LF	TRENCHLESS INSTALLATION OF 12" IN SOIL
5871710000-E	1550	37	LF	TRENCHLESS INSTALLATION OF 12" NOT IN SOIL
6000000000-E	1605	1,850	LF	TEMPORARY SILT FENCE
6006000000-E	1610	405	TON	STONE FOR EROSION CONTROL, CLASS A
6009000000-E	1610	265	TON	STONE FOR EROSION CONTROL, CLASS B
6012000000-E	1610	260	TON	SEDIMENT CONTROL STONE
6015000000-E	1615	2	ACR	TEMPORARY MULCHING
6018000000-E	1620	100	LB	SEED FOR TEMPORARY SEEDING
6021000000-E	1620	1.25	TON	FERTILIZER FOR TEMPORARY SEEDING
6024000000-E	1622	200	LF	TEMPORARY SLOPE DRAINS
6029000000-E	SP	300	LF	SAFETY FENCE
6030000000-E	1630	810	CY	SILT EXCAVATION
6036000000-E	1631	2,500	SY	MATting FOR EROSION CONTROL
6037000000-E	SP	40	SY	COIR FIBER MAT
6038000000-E	SP	1,500	SY	PERMANENT SOIL REINFORCEMENT MAT
6042000000-E	1632	680	LF	1/4" HARDWARE CLOTH
6071010000-E	SP	235	LF	WATTLE
6071020000-E	SP	100	LB	POLYACRYLAMIDE (PAM)

ItemNumber	Sec #	Quantity	Unit	Description
6071030000-E	1640	260	LF	COIR FIBER BAFFLE
6071050000-E	SP	4	EA	*** SKIMMER (1-1/2")
6084000000-E	1660	2	ACR	SEEDING & MULCHING
6087000000-E	1660	2	ACR	MOWING
6090000000-E	1661	50	LB	SEED FOR REPAIR SEEDING
6093000000-E	1661	0.25	TON	FERTILIZER FOR REPAIR SEEDING
6096000000-E	1662	50	LB	SEED FOR SUPPLEMENTAL SEEDING
6108000000-E	1665	1.5	TON	FERTILIZER TOPDRESSING
6114500000-N	1667	10	MHR	SPECIALIZED HAND MOWING
6117000000-N	SP	18	EA	RESPONSE FOR EROSION CONTROL

5/28/99

15-NOV-2011 4:01 P.M. R:\ROADWAY\ES\B4050_rdy_sum.dgn

12/06/07

COMPUTED BY: D. W. GARDNER DATE: 10/25/11
CHECKED BY: M. T. POTTS DATE: 11/8/11

STATE OF NORTH CAROLINA
DIVISION OF HIGHWAYS

PROJECT REFERENCE NO. B-4050
SHEET NO. 3-A

WOVEN WIRE FENCE SUMMARY

Table with columns: SURVEY LINE, STATION, STATION, LT./RT., FABRIC LF, 4" POSTS, 5" POSTS. Includes rows for various stationing and a GRAND TOTALS row.

REMOVE AND RESET METAL GATE AT -DRV1- STA. 10+80.00
REMOVE AND RESET METAL GATE AT -DRV3- STA. 10+16.00
50" WW & 1 SBW FENCE RESET = 55 LF

SHOULDER BERM GUTTER SUMMARY

Table with columns: SURVEY LINE, STATION, STATION, LOCATION LT/RT/CL, LINEAR FEET. Includes rows for stationing and a TOTAL row.

SUMMARY OF BREAKING EXISTING ASPHALT PAVEMENT

Table with columns: SURVEY LINE, STATION, STATION, LOCATION LT/RT/CL, YD'. Includes rows for stationing and a TOTAL row.

Note: Approximate quantities only. Unclassified Excavation, Borrow Excavation, Fine Grading, Clearing and Grubbing, Breaking of Existing Pavement, and Removal of Existing Pavement will be paid for at the contract lump sum price for "Grading."

Earthwork quantities are calculated by the Roadway Design Unit. These earthwork quantities are based in part on subsurface data provided by the Geotechnical Engineering Unit.

SUMMARY OF EARTHWORK IN CUBIC YARDS

Large summary table with columns: STATION, STATION, UNCL. EXCAV., EMBANK. +%, BORROW, WASTE. Includes subtotals for SUMMARY NO. 1, SUMMARY NO. 2, and GRAND TOTALS.

PAVEMENT REMOVAL SUMMARY

Table with columns: SURVEY LINE, STATION, STATION, LOCATION LT/RT/CL, YD'. Includes rows for stationing and a TOTALS row.

NOTE: Invert Elevations are for Bid Purposes only and shall not be used for project construction stakeout. See "Standard Specifications For Roads and Structures, Section 300-5".

SUB-REGIONAL LIST OF PIPES, ENDWALLS, ETC. (FOR PIPES 48" & UNDER)

Main table listing pipe details: STATION, LOCATION, STRUCTURE NO., TOP ELEVATION, INVERT ELEVATION, SLOPE CRITICAL, DRAINAGE PIPE, C.S. PIPE, R.C. PIPE (CLASS III), R.C. PIPE (CLASS IV), ENDWALLS, QUANTITIES FOR DRAINAGE STRUCTURES, FRAME, GRATES AND HOOD STANDARD 840.03, CONCRETE TRANSITIONAL SECTION, PIPE REMOVAL LIN.FT., and REMARKS.

"N" = DISTANCE FROM EDGE OF LANE TO FACE OF GUARDRAIL.
TOTAL SHOULDER WIDTH = DISTANCE FROM EDGE OF TRAVEL LANE TO SHOULDER BREAK POINT.
FLARE LENGTH = DISTANCE FROM LAST SECTION OF PARALLEL GUARDRAIL TO END OF GUARDRAIL.
W = TOTAL WIDTH OF FLARE FROM BEGINNING OF TAPER TO END OF GUARDRAIL.
G = GATING IMPACT ATTENUATOR TYPE 350
NG = NON-GATING IMPACT ATTENUATOR TYPE 350

GUARDRAIL SUMMARY

Table with columns: SURVEY LINE, BEG. STA., END STA., LOCATION, LENGTH (STRAIGHT, SHOP CURVED, DOUBLE FACED), WARRANT POINT (APPROACH END, TRAILING END), "N" DIST. FROM E.O.L., TOTAL SHOUL. WIDTH, FLARE LENGTH (APPROACH END, TRAILING END), W (APPROACH END, TRAILING END), ANCHORS (GRAU 350, TYPE III), IMPACT ATTENUATOR TYPE 350 (EA, G, NG), SINGLE FACED GUARDRAIL, REMOVE EXISTING GUARDRAIL, REMOVE AND STOCKPILE EXISTING GUARDRAIL, and REMARKS.

30-NOV-2011 12:28
P:\Roadway\proj\11b4050\rdy_sum.dgn

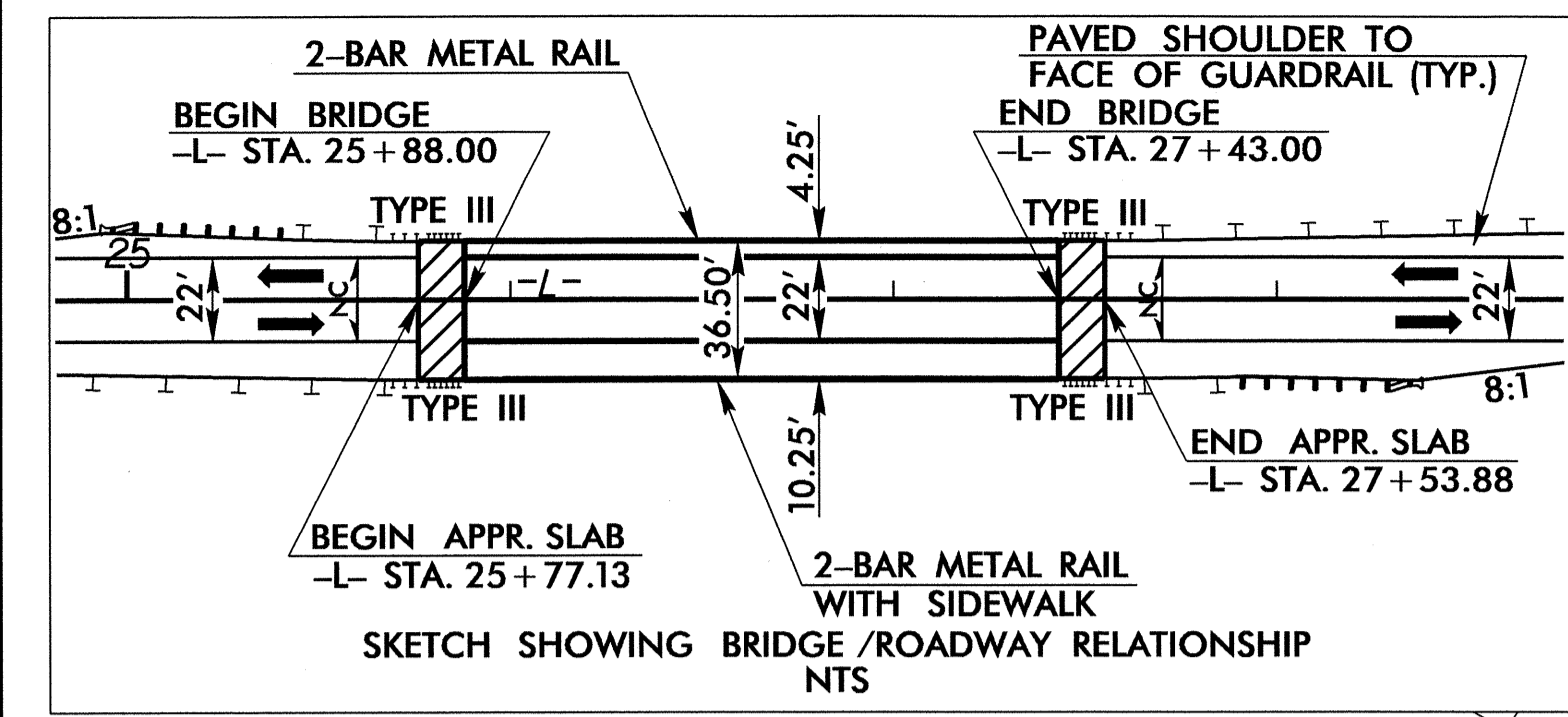

-L-			-DRV1-		-DRV2-	
PI Sta 20+29.83	PI Sta 29+10.52	PI Sta 33+45.92	PI Sta 10+24.61	PI Sta 10+52.95		
$\Delta = 2^{\circ} 34' 29.0''$ (RT)	$\Delta = 0^{\circ} 36' 56.5''$ (RT)	$\Delta = 0^{\circ} 16' 20.1''$ (LT)	$\Delta = 29^{\circ} 29' 54.5''$ (RT)	$\Delta = 45^{\circ} 46' 03.5''$ (RT)		
D = 0' 38' 11.8"	D = 0' 34' 22.6"	D = 0' 15' 37.6"	D = 114' 35' 29.6"	D = 114' 35' 29.6"		
L = 404.44'	L = 107.46'	L = 104.54'	L = 25.74'	L = 39.94'		
T = 202.25'	T = 53.73'	T = 52.27'	T = 13.16'	T = 21.10'		
R = 9,000.00'	R = 10,000.00'	R = 22,000.00'	R = 50.00'	R = 50.00'		
SE = SEE PLANS	SE = SEE PLANS	SE = SEE PLANS	SE = SEE PLANS	SE = SEE PLANS		

-DRV3-	
PI Sta 10+31.43	PI Sta 13+92.23
$\Delta = 43^{\circ} 04' 06.8''$ (LT)	$\Delta = 90^{\circ} 36' 56.5''$ (RT)
D = 143' 14" 22.0"	D = 143' 14" 22.0"
L = 30.07'	L = 63.26'
T = 15.78'	T = 40.43'
R = 40.00'	R = 40.00'
SE = SEE PLANS	SE = SEE PLANS

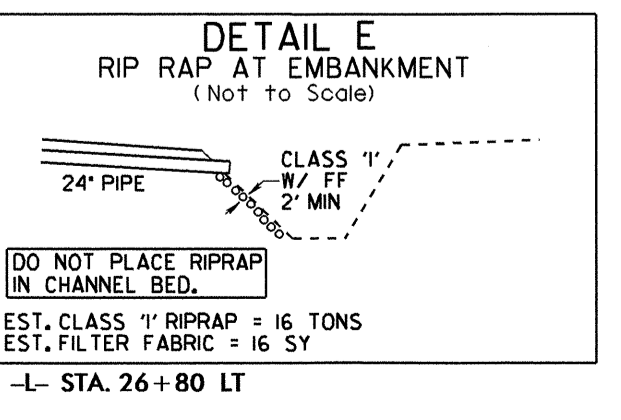
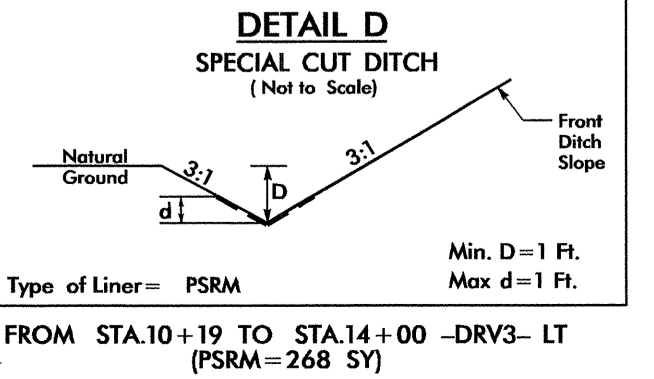
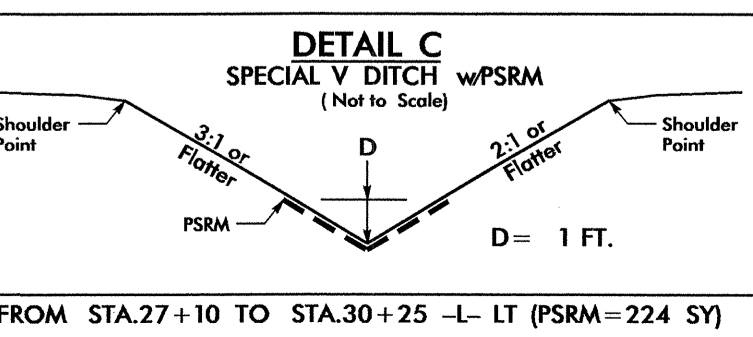
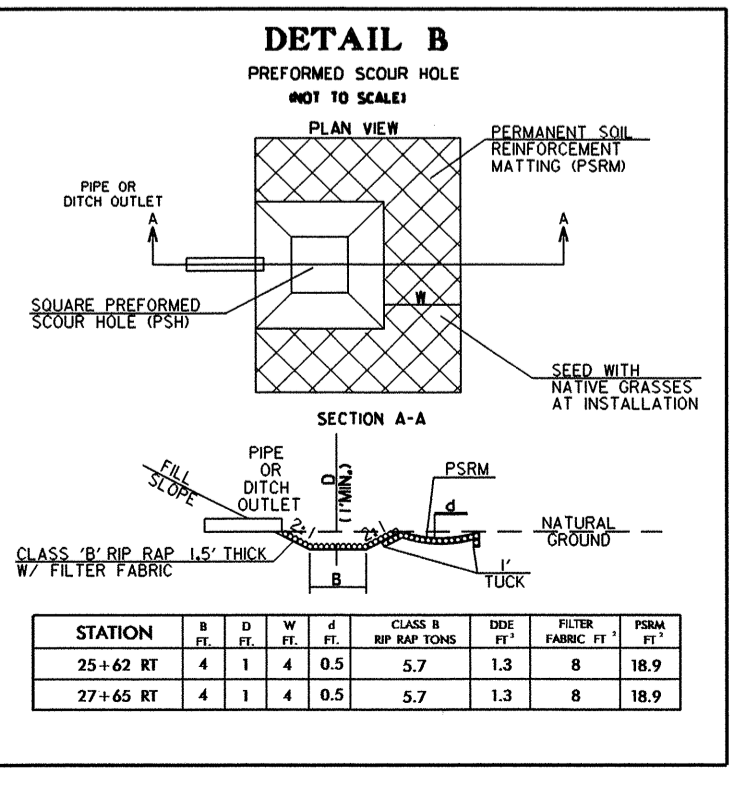
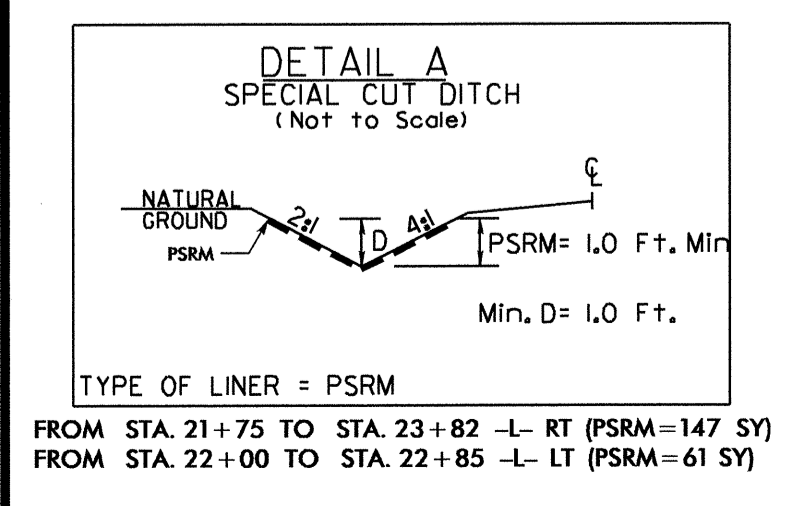
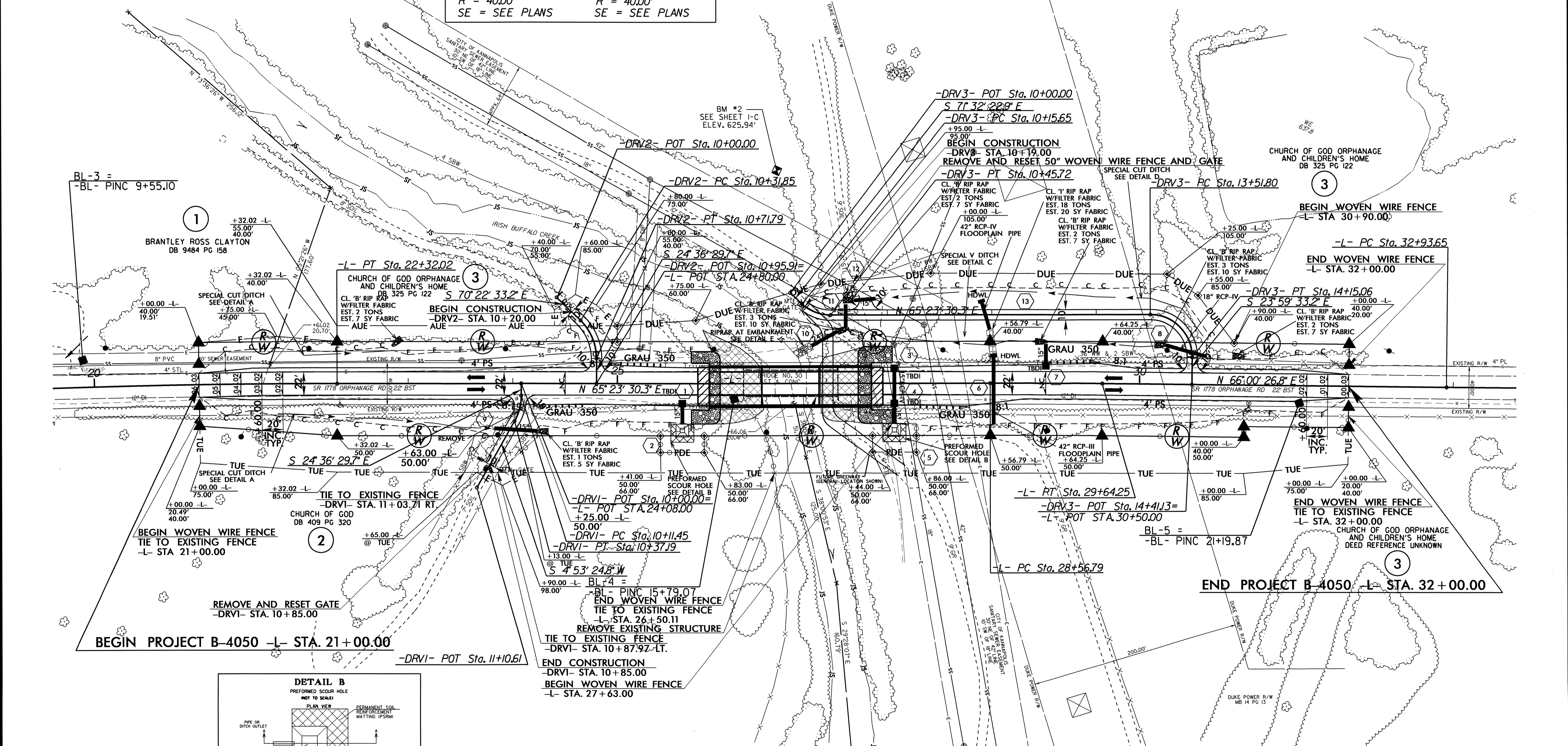
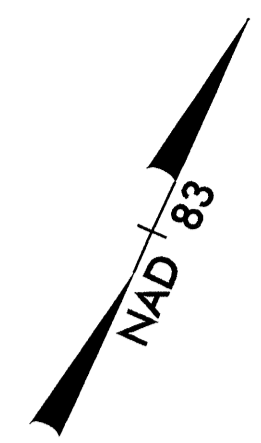

NOTE: PAVE DRIVES TO PROPOSED RW.

NOTE: TRANSITION 4' PAVED SHOULDER TO EXISTING
-L- STA. 21+00 TO 21+50 LT/RT.
-L- STA. 31+50 TO 32+00 LT/RT.

SEE SHEET 5 FOR -L- PROFILE
SEE SHEET 5 FOR -DRV1- PROFILE
SEE SHEET 5 FOR -DRV2- PROFILE
SEE SHEET 6 FOR -DRV3- PROFILE
SEE SHEETS S-1 THRU S-27 FOR STRUCTURE PLANS

8/17/99
15-NOV-2011 14:00
C:\Roadway\Projects\B-4050_rdy_psh.dgn

5/28/99

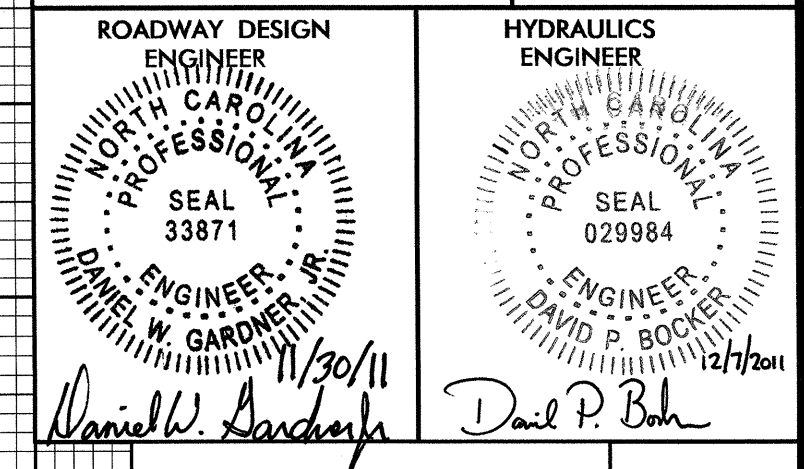

BRIDGE HYDRAULIC DATA

DESIGN DISCHARGE	= 8300	CFS
DESIGN FREQUENCY	= 50	YRS
DESIGN HW ELEVATION	= 629.5	FT
BASE DISCHARGE	= 8900	CFS
BASE FREQUENCY	= 100	YRS
BASE HW ELEVATION	= 629.7	FT
OVERTOPPING DISCHARGE	= 8260	CFS
OVERTOPPING FREQUENCY	= 10+	YRS
OVERTOPPING ELEVATION	= 629.0	FT
DATE OF SURVEY	= 7/29/08	
W.S. ELEVATION AT DATE OF SURVEY	= 614.6	FT

BM1 ELEVATION = 678.31'
 N 620322 E 1510475
 L- STATION 16+25 45' RIGHT
 NCSHC 7J514

BM2 ELEVATION = 625.94'
 N 620993 E 1511292
 L- STATION 26+53 203' LEFT
 RR SPIKE IN 18" SWEETGUM

PI = 22+90.00
 EL = 632.66'
 VC = 380'
 K = 60 (DS > 35 MPH)

PI = 30+60.00
 EL = 628.33'
 VC = 280'
 K = 50 (DS > 35 MPH)

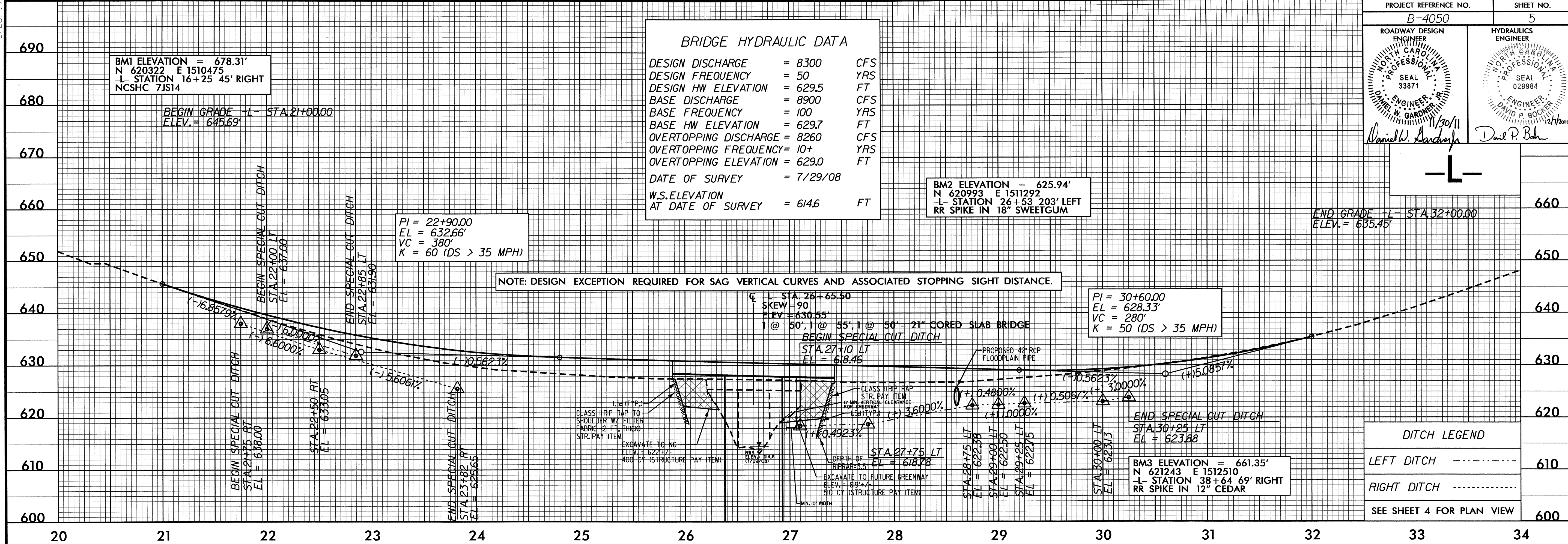

DITCH LEGEND

LEFT DITCH	---
RIGHT DITCH	---
SEE SHEET 4 FOR PLAN VIEW	

-DRV1-

-DRV2-

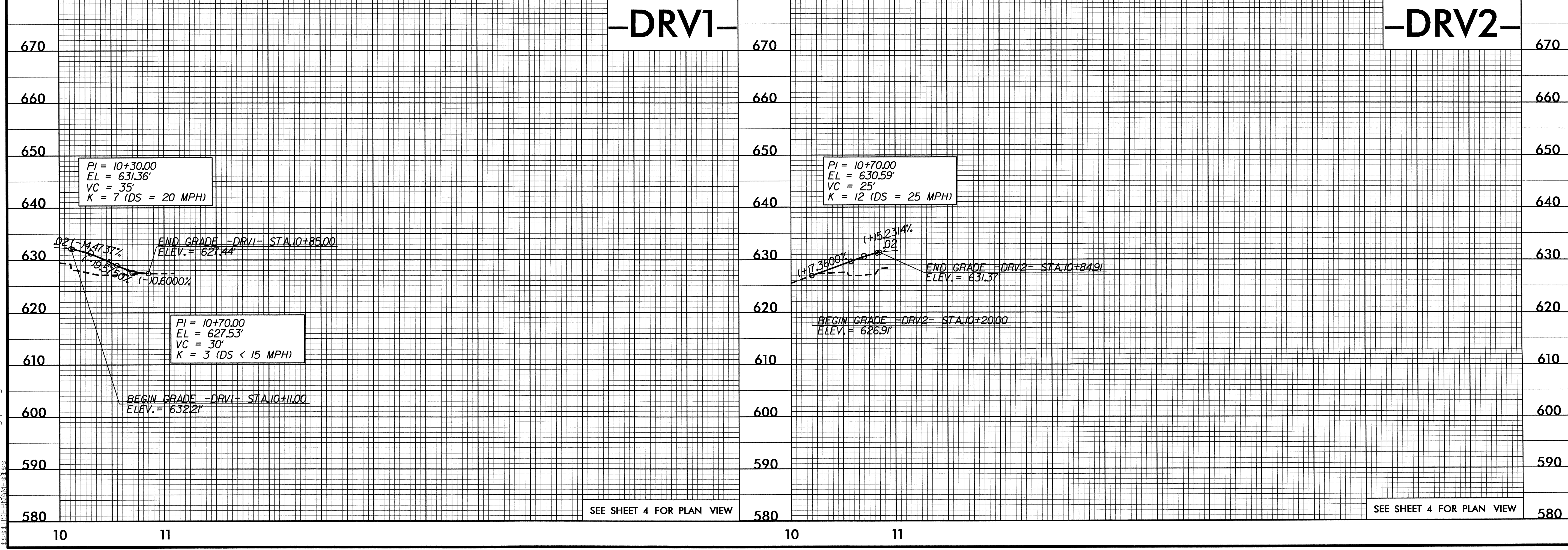

PI = 10+30.00
 EL = 631.36'
 VC = 35'
 K = 7 (DS = 20 MPH)

PI = 10+70.00
 EL = 630.59'
 VC = 25'
 K = 12 (DS = 25 MPH)

PI = 10+70.00
 EL = 627.53'
 VC = 30'
 K = 3 (DS < 15 MPH)

SEE SHEET 4 FOR PLAN VIEW

SEE SHEET 4 FOR PLAN VIEW

10-V-2011-1452-1-b-4050-r-dw-pl.dgn

5/28/99

ROADWAY DESIGN ENGINEER NORTH CAROLINA PROFESSIONAL SEAL 33871 DANIEL W. GARDNER 12/30/11	HYDRAULICS ENGINEER NORTH CAROLINA PROFESSIONAL SEAL 029984 DAVID P. BOYER 12/1/2011
--	---

-DRV3-

