

WBS 17BP.1.P.3

CONTRACT #C202915

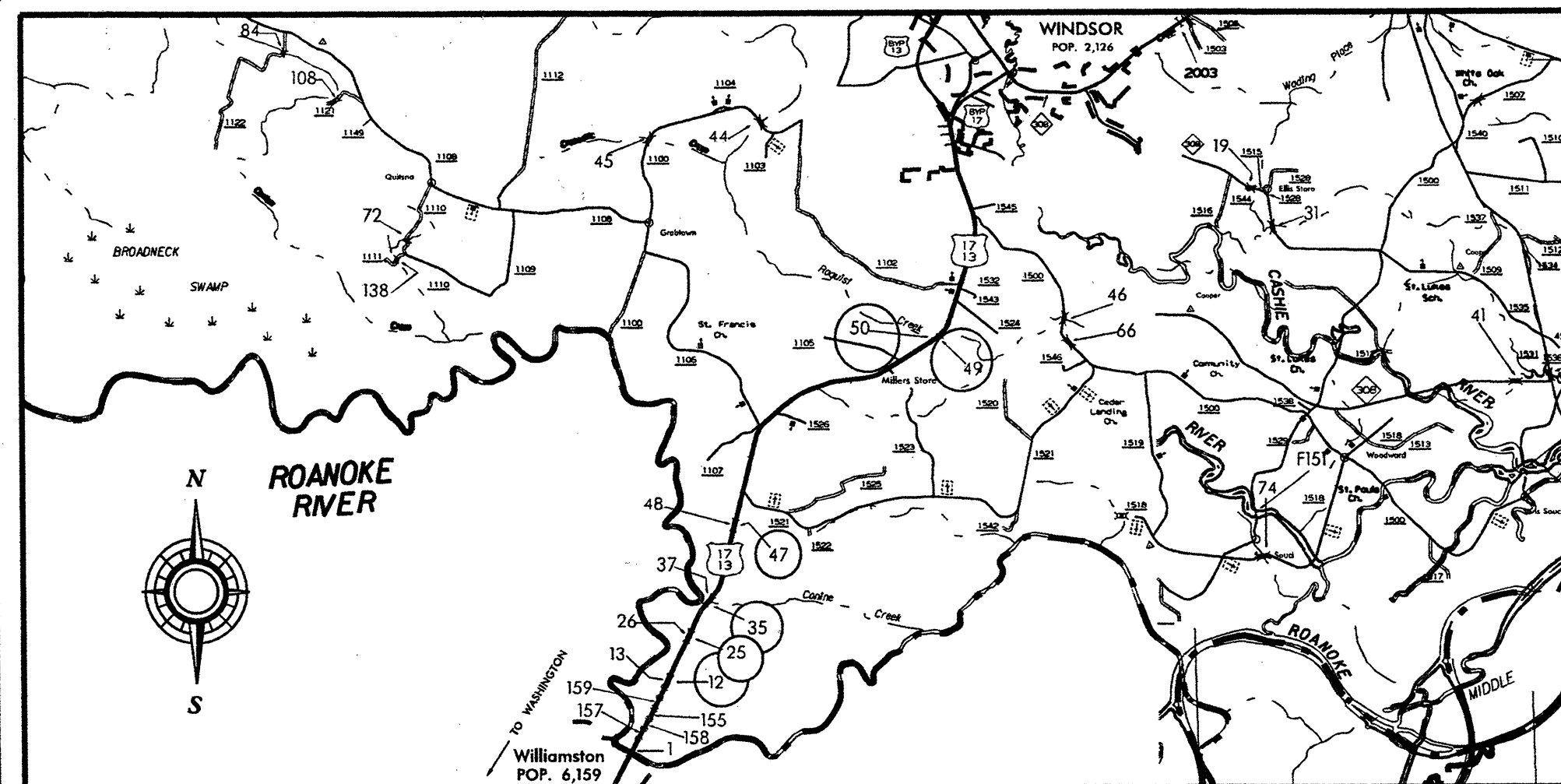

BERTIE COUNTY

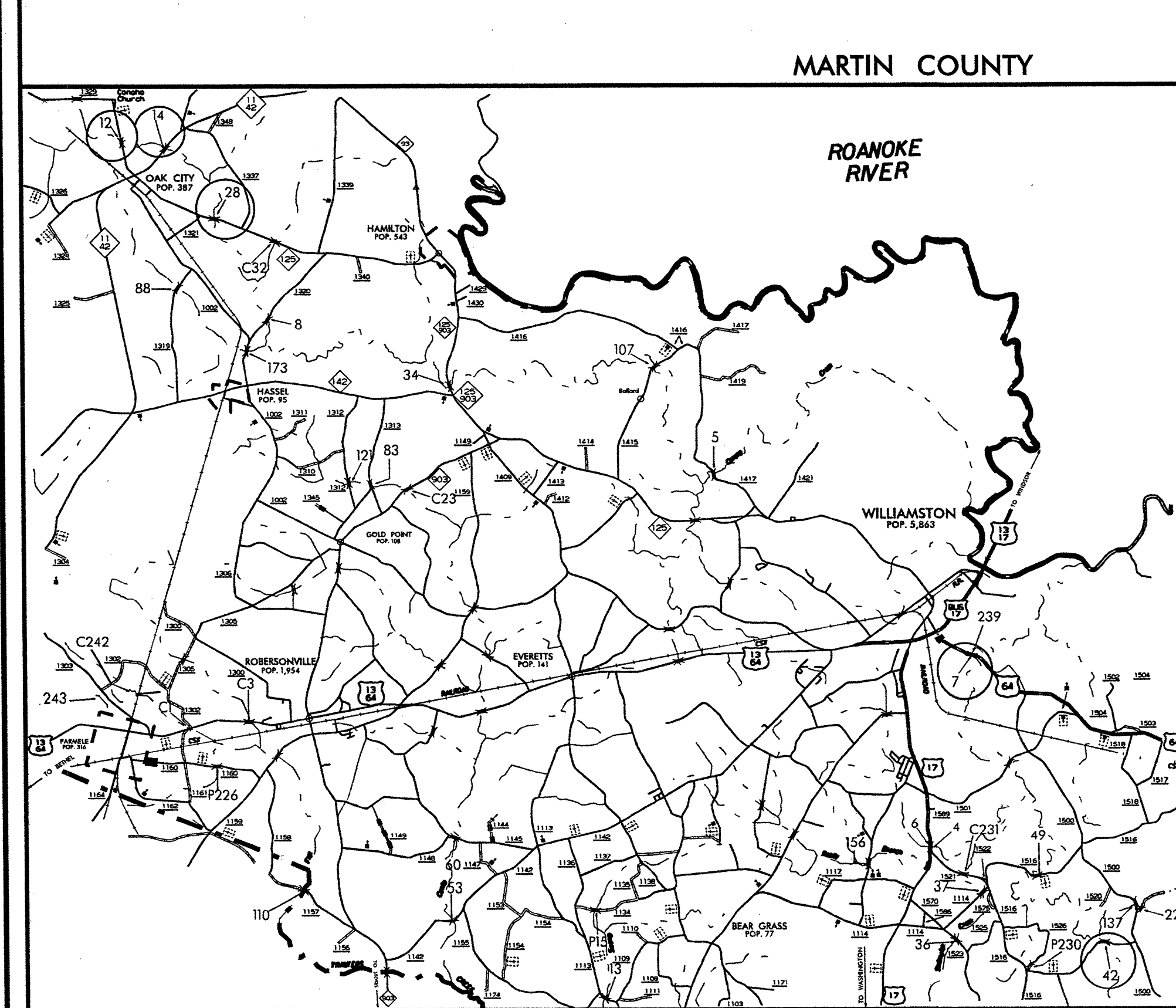

VICINITY MAP

STATE OF NORTH CAROLINA
DIVISION OF HIGHWAYS

BERTIE AND MARTIN COUNTIES

STATE	STATE PROJECT REFERENCE NO.	SHEET NO.	TOTAL SHEETS
N.C.	17BP.1.P.3	1	50
STATE PROJ. NO.		P.A. PROJ. NO.	DESCRIPTION
17BP.1.P.3		N/A	PE
17BP.1.P.3		N/A	CONST

LOCATION: BRIDGE #12, BERTIE CO., ON US13 SBL OVER ROANOKE RIVER
BRIDGE #25, BERTIE CO., ON US13 NBL OVER ROANOKE RIVER
BRIDGE #47, BERTIE CO., ON US13 NBL OVER ROANOKE RIVER

BRIDGE #07, MARTIN CO., ON US64 EBL OVER SWEATWATER CREEK
BRIDGE #12, MARTIN CO., ON NCI25 OVER CONOHO CREEK
BRIDGE #14, MARTIN CO., ON NC11 OVER CONOHO CREEK
BRIDGE #28, MARTIN CO., ON NCI25 OVER CONOHO CREEK

TYPE OF WORK: BRIDGE PRESERVATION WITH LATEX MODIFIED CONCRETE.

LOCATION: BRIDGE #35, BERTIE CO., ON US13 NBL OVER CONNIE CREEK
BRIDGE #49, BERTIE CO., ON US13 NBL OVER ROQUIST CREEK
BRIDGE #50, BERTIE CO., ON US13 SBL OVER ROQUIST CREEK
BRIDGE #42, MARTIN CO., ON SR1528 OVER HARDISON MILL CREEK

TYPE OF WORK: BRIDGE PRESERVATION WITH LATEX MODIFIED CONCRETE AND PILE ENCAPSULATION.

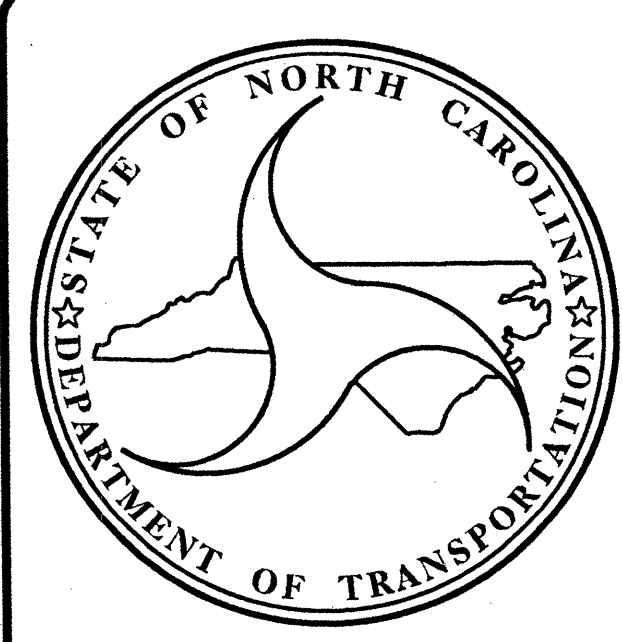
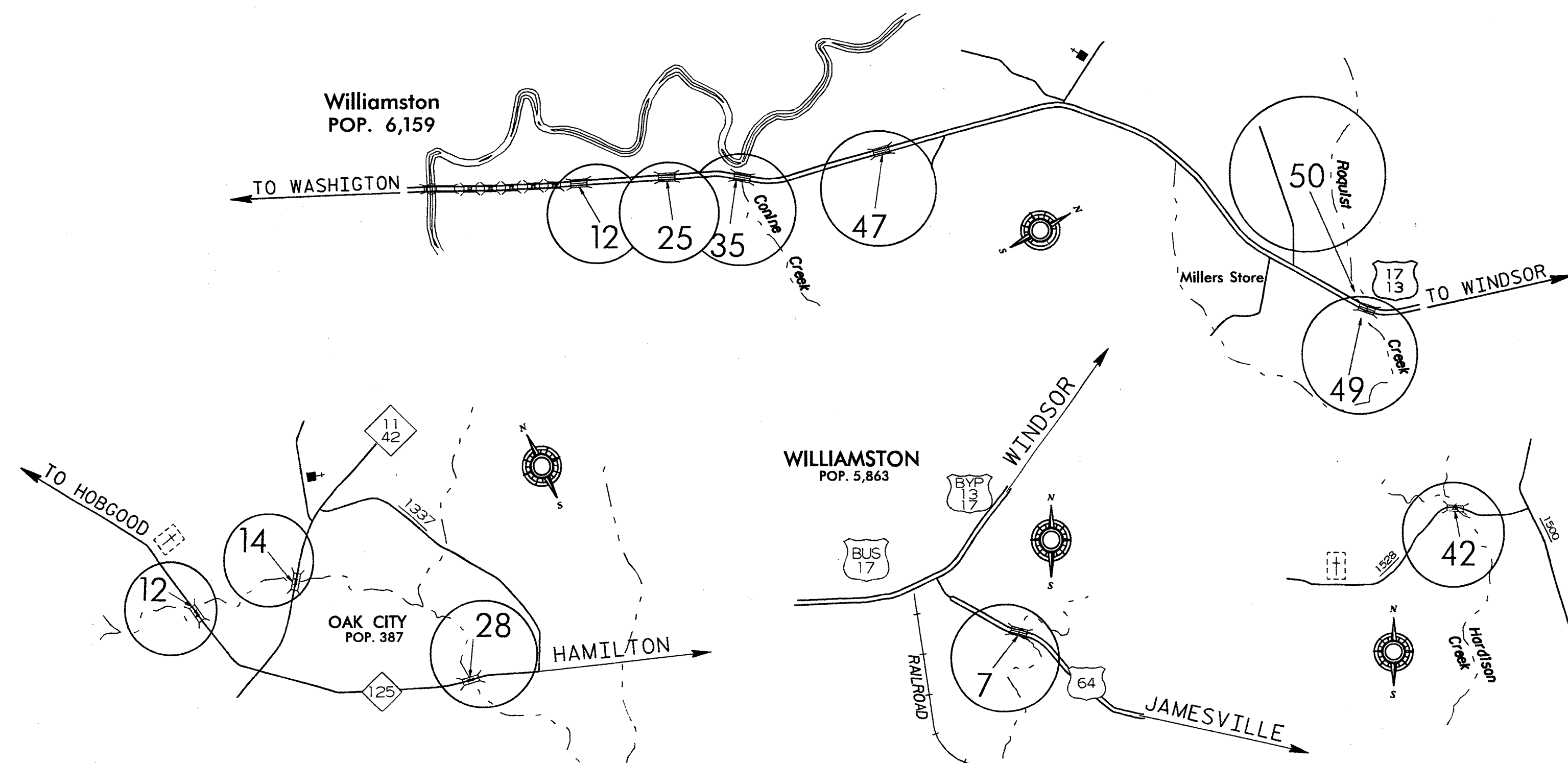
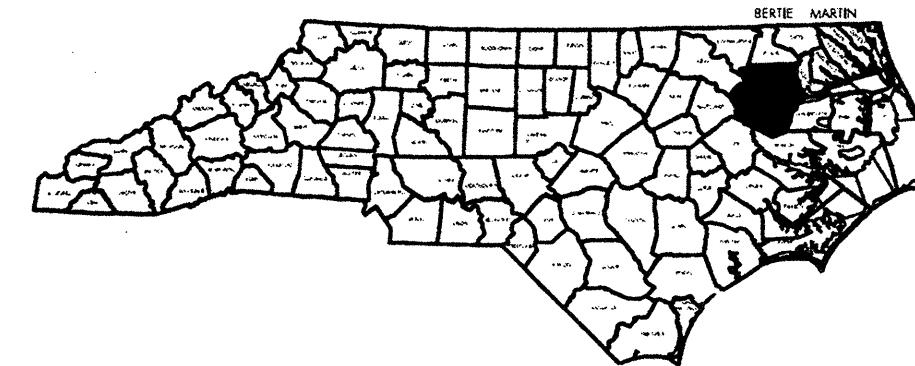

DESIGN DATA

BERTIE	
#12 ADT 2008	= 6000
#25 ADT 2008	= 6000
#35 ADT 2008	= 6000
#47 ADT 2008	= 6000
#49 ADT 2009	= 5000
#50 ADT 2009	= 5000
MARTIN	
#7 ADT 2008	= 3000
#12 ADT 2008	= 1600
#14 ADT 2008	= 3800
#28 ADT 2008	= 840
#42 ADT 2008	= 190

PROJECT LENGTH

BRIDGE BERTIE #12	=	.042 MILE
BRIDGE BERTIE #25	=	.042 MILE
BRIDGE BERTIE #35	=	.142 MILE
BRIDGE BERTIE #47	=	.055 MILE
BRIDGE BERTIE #49	=	.025 MILE
BRIDGE BERTIE #50	=	.025 MILE
BRIDGE MARTIN #7	=	.023 MILE
BRIDGE MARTIN #12	=	.021 MILE
BRIDGE MARTIN #14	=	.025 MILE
BRIDGE MARTIN #28	=	.028 MILE
BRIDGE MARTIN #42	=	.028 MILE

Prepared In the Office of:
DIVISION OF BRIDGE MANAGEMENT
2012 STANDARD SPECIFICATIONS

LETTING DATE:
FEBRUARY 21, 2012

GREG PERFETTI, PE
PROJECT ENGINEER

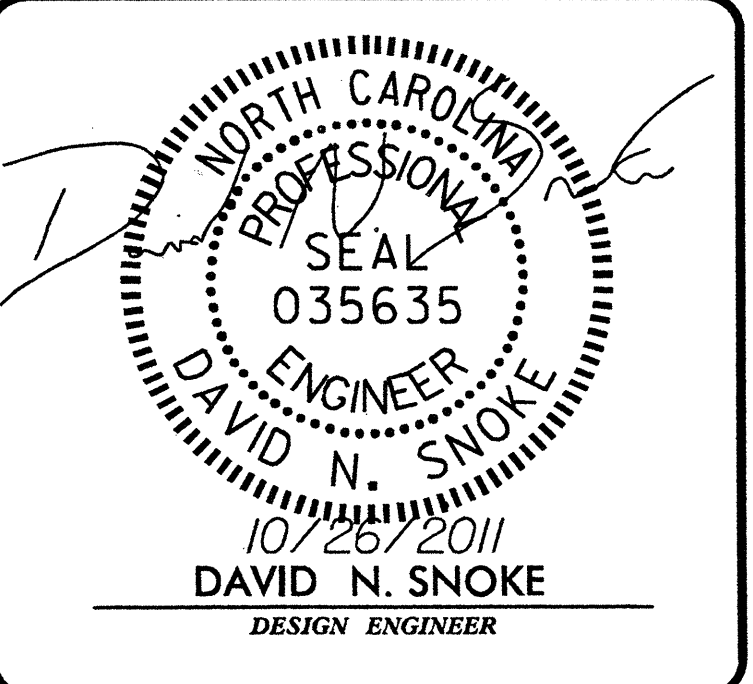

WBS 17BP.1.P.3

CONTRACT #C202915

STATE OF NORTH CAROLINA
DIVISION OF HIGHWAYS

BERTIE AND MARTIN COUNTIES

LOCATION: BRIDGE #12, BERTIE CO., ON US13 SBL OVER ROANOKE RIVER
BRIDGE #25, BERTIE CO., ON US13 NBL OVER ROANOKE RIVER
BRIDGE #47, BERTIE CO., ON US13 NBL OVER ROANOKE RIVER

BRIDGE #07, MARTIN CO., ON US64 EBL OVER SWEATWATER CREEK
BRIDGE #12, MARTIN CO., ON NC125 OVER CONOHO CREEK
BRIDGE #14, MARTIN CO., ON NC11 OVER CONOHO CREEK
BRIDGE #28, MARTIN CO., ON NC125 OVER CONOHO CREEK

TYPE OF WORK: BRIDGE PRESERVATION WITH LATEX MODIFIED CONCRETE.

LOCATION: BRIDGE #35, BERTIE CO., ON US13 NBL OVER CONNIE CREEK
BRIDGE #49, BERTIE CO., ON US13 NBL OVER ROQUIST CREEK
BRIDGE #50, BERTIE CO., ON US13 SBL OVER ROQUIST CREEK
BRIDGE #42, MARTIN CO., ON SR1528 OVER HARDISON MILL CREEK

TYPE OF WORK: BRIDGE PRESERVATION WITH LATEX MODIFIED CONCRETE
AND PILE ENCAPSULATION.

STATE	STATE PROJECT REFERENCE NO.	SHEET NO.	TOTAL SHEETS
N.C.	17BP.1.P.3	1A	50
STATE PROJ. NO.	F.A. PROJ. NO.	DESCRIPTION	
17BP.1.P.3	NA	PE	
17BP.1.P.3	NA	CONST	

INDEX OF SHEETS

1	TITLE SHEET
1A	INDEX OF SHEETS
2	SUMMARY OF QUANTITIES
S1-S50	STRUCTURES
TMP-1 - TMP-6	TRAFFIC MANAGEMENT PLANS

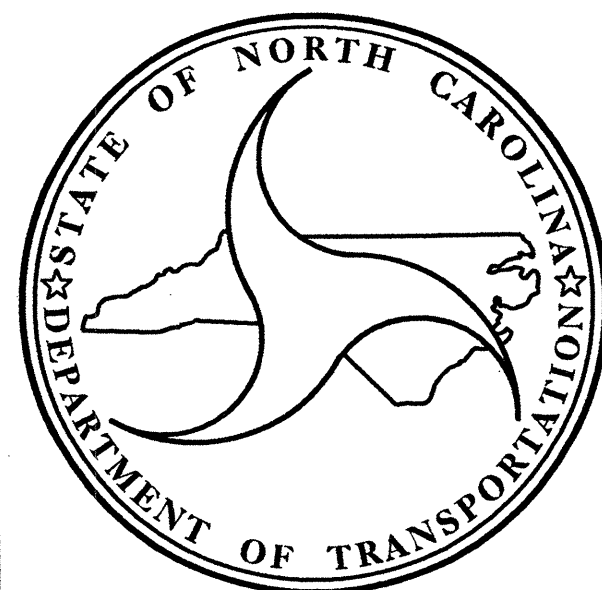

Prepared in the Office of:
DIVISION OF BRIDGE MANAGEMENT
2012 STANDARD SPECIFICATIONS

LETTING DATE: FEBRUARY 21, 2012	GREG PERFETTI, PE PROJECT ENGINEER
------------------------------------	---------------------------------------

DAVID SNOKE, P.E.
PROJECT DESIGN ENGINEER

COMPUTED BY: _____ DATE _____
 CHECKED BY: _____ DATE _____

STATE PROJECT REFERENCE NO. _____ SHEET NO. _____
 17BPLP2 3

STATE OF NORTH CAROLINA DIVISION OF HIGHWAYS

SUMMARY OF QUANTITIES

STATE OF NORTH CAROLINA
 DIVISION OF HIGHWAYS
 ROADWAY SUMMARY OF QUANTITIES FOR CONTRACT - C202915

ItemNumber	Sec #	Quantity	Unit	Description	ItemNumber	Sec #	Quantity	Unit	Description
0000100000-N	800	Lump Sum		MOBILIZATION	8867000000-E	SP	550	LF	GENERIC STRUCTURE ITEM PIPE ENCAPSULATION
1519000000-E	610	384	TON	ASPHALT CONC SURFACE COURSE, TYPE S9.5B	8893000000-E	SP	9,193	SY	GENERIC STRUCTURE ITEM HYDRO-DEMOLITION OF BRIDGE DECK
1575000000-E	620	23	TON	ASPHALT BINDER FOR PLANT MIX	8893000000-E	SP	14,085	SY	GENERIC STRUCTURE ITEM SCARIFYING BRIDGE DECK
4400000000-E	1110	974	SF	WORK ZONE SIGNS (STATIONARY)					
4405000000-E	1110	433	SF	WORK ZONE SIGNS (PORTABLE)					
4410000000-E	1110	144	SF	WORK ZONE SIGNS (BARRICADE MOUNTED)					
4415000000-N	1115	3	EA	FLASHING ARROW BOARD					
4420000000-N	1120	3	EA	PORTABLE CHANGEABLE MESSAGE SIGN					
4430000000-N	1130	400	EA	DRUMS					
4435000000-N	1135	50	EA	CONES					
4445000000-E	1145	112	LF	BARRICADES (TYPE III)					
4450000000-N	1150	160	HR	FLAGGER					
4465000000-N	1160	1	EA	TEMPORARY CRASH CUSHIONS					
4470000000-N	1160	5	EA	RESET TEMPORARY CRASH CUSHION					
4480000000-N	1165	2	EA	TMA					
4485000000-E	1170	1,700	LF	PORTABLE CONCRETE BARRIER					
4500000000-E	1170	9,050	LF	RESET PORTABLE CONCRETE BAR- RIER					
4589000000-N	SP	Lump Sum		GENERIC TRAFFIC CONTROL ITEM AUTOMATED FLAGGER ASSISTANCE DEVICE SYSTEMS					
4847000000-E	1205	9,032	LF	POLYUREA PAVEMENT MARKING LINES (4", *****) (STANDARD GLASS BEADS)					
4900000000-N	1251	45	EA	PERMANENT RAISED PAVEMENT MARKERS					
8161000000-E	420	73,186	SF	GROOVING BRIDGE FLOORS					
8573000000-E	SP	360	CY	LATEX MODIFIED CONC OVERLAY					
8580000000-E	SP	9,193	SY	PLACING & FINISHING OF LATEX MODIFIED CONC OVERLAY					
8692000000-N	SP	Lump Sum		FOAM JOINT SEALS					

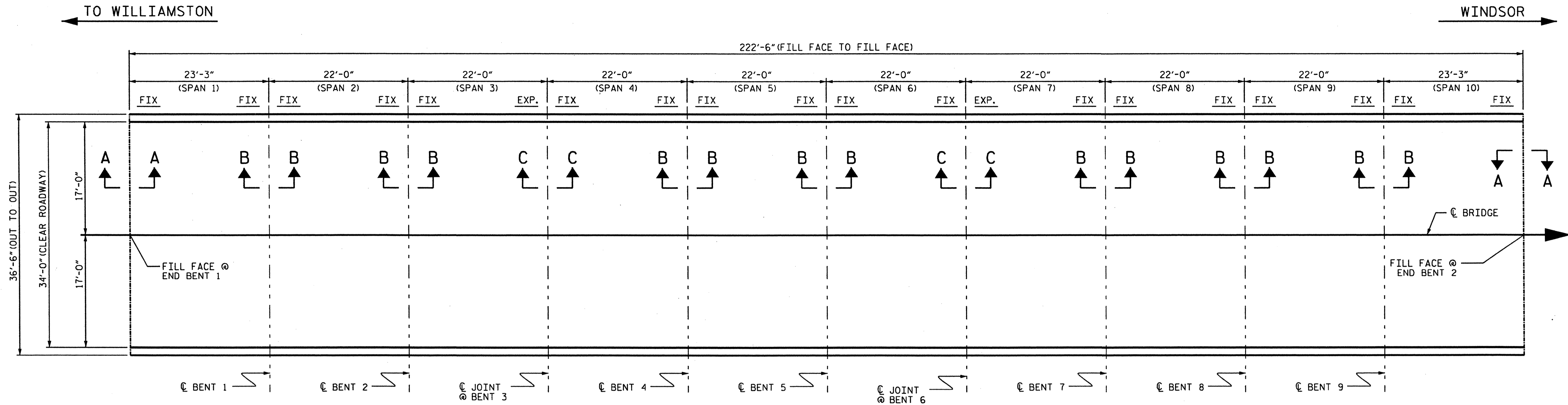

PLAN OF SPANS- DECK REPAIRS

APPROX. AREA: CLASS II REPAIR
 APPROX. AREA: CLASS III REPAIR

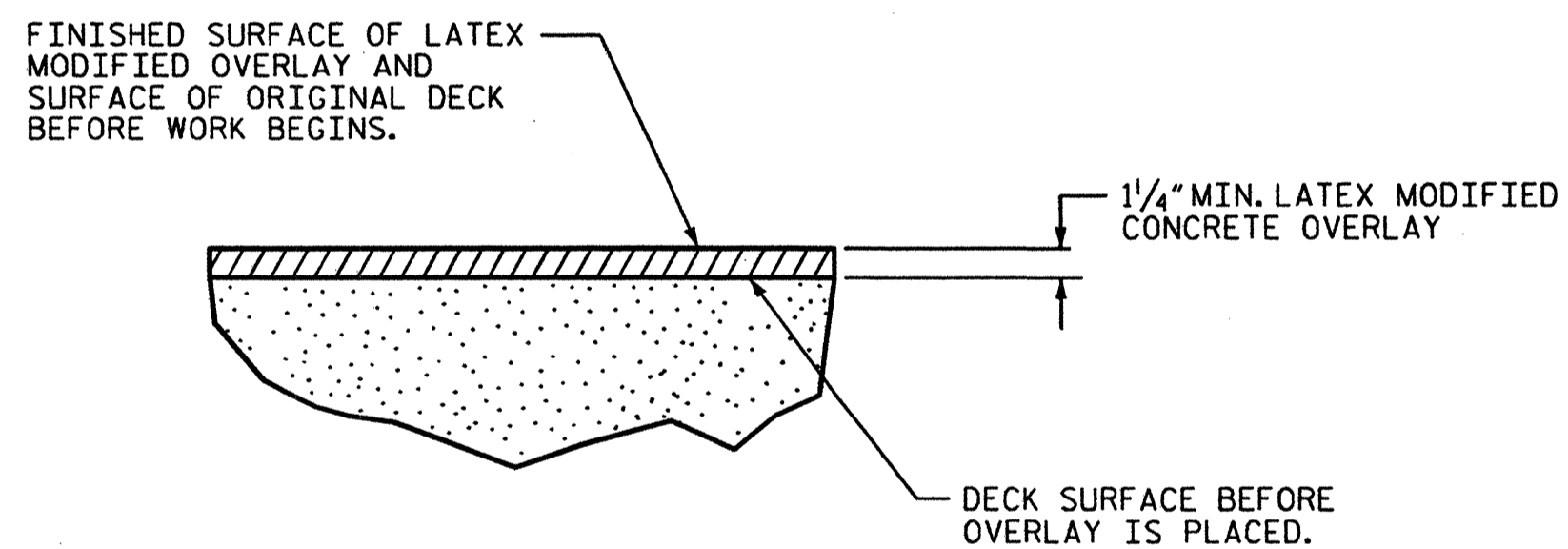

DETAIL FOR LATEX MODIFIED CONCRETE OVERLAY

PROJECT NO. 17BP.1.P.3
 COUNTY: BERTIE
 DECK REPAIR BRIDGE NO. 12
 SHEET 1 OF 3

TOTAL BILL OF MATERIAL									
SCARIFYING BRIDGE DECK	CLASS I SURFACE PREPARATION	CLASS II SURFACE PREPARATION	CLASS III SURFACE PREPARATION	HYDRO-DEMOLITION OF BRIDGE DECK	LATEX MODIFIED CONCRETE OVERLAY	PLACING & FINISHING LATEX MODIFIED CONCRETE OVERLAY	FOAM JOINT SEALS	GROOVING BRIDGE FLOORS	ASPHALT CONC. SURF. COURSE TYPE S9.5B
SQ.YDS.	SQ.YDS.	SQ.YDS.	SQ.YDS.	SQ.YDS.	C.Y.	SQ.YDS.	LUMP SUM	SQ. FT.	TON
974	0	0	0	841	35.0	841	LUMP SUM	6,774	12

* QUANTITIES ARE SHOWN FOR INFORMATIONAL PURPOSES ONLY. IF ANY CLASS III LOCATIONS ARE ENCOUNTERED PRIOR TO OR DURING HYDRO-DEMOLITION, SEE TYP. "BLOW THRU" CONTAINMENT AND FALSEWORK DETAILS.
 ** INCLUDES MILLING OF ROADWAY PAVEMENT.

STATE OF NORTH CAROLINA
DEPARTMENT OF TRANSPORTATION
RALEIGH

PLAN OF BRIDGE AND BILL OF MATERIALS

34'-0" CLEAR ROADWAY (90°-00' SKEW)

REVISIONS						SHEET NO.
NO.	BY:	DATE:	NO.	BY:	DATE:	S-1
1			3			TOTAL SHEETS
2			4			50

DRAWN BY : K.H. COMPTON DATE : 9/11
 CHECKED BY : D. SNOKE DATE : 9/11

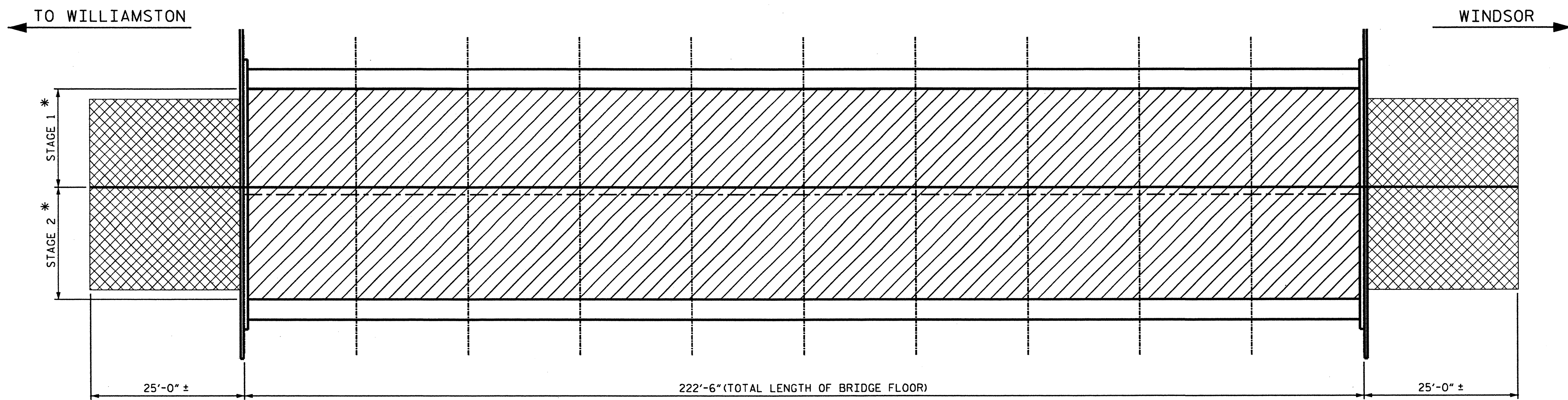

*SEE STAGING PLAN IN TRAFFIC CONTROL PLAN. SHEET ???

PLAN

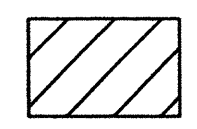
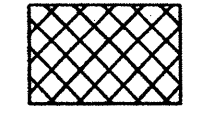
-  DECK SCARIFICATION AND HYDRODEMOLITION
-  MILLING OF ROADWAY APPROACH

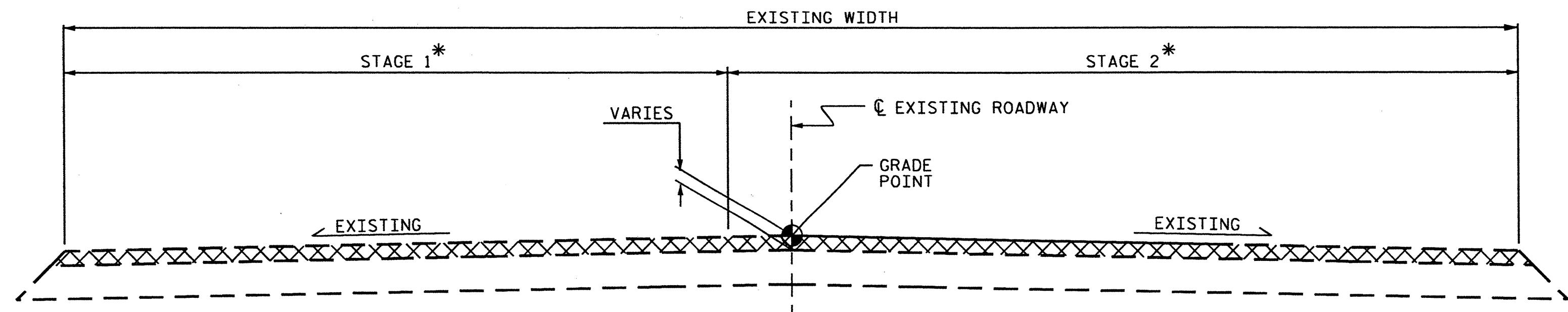

TYPICAL ROADWAY MILLING SECTION

C1 PROPOSED VARIABLE DEPTH ASPHALT CONCRETE SURFACE COURSE, TYPE SF 9.5B AT AN AVERAGE RATE OF 110 LBS. PER SQ. YD. PER 1" DEPTH. TO BE PLACED IN LAYERS NOT LESS THAN 1" IN DEPTH OR GREATER THAN 1/2" IN DEPTH.

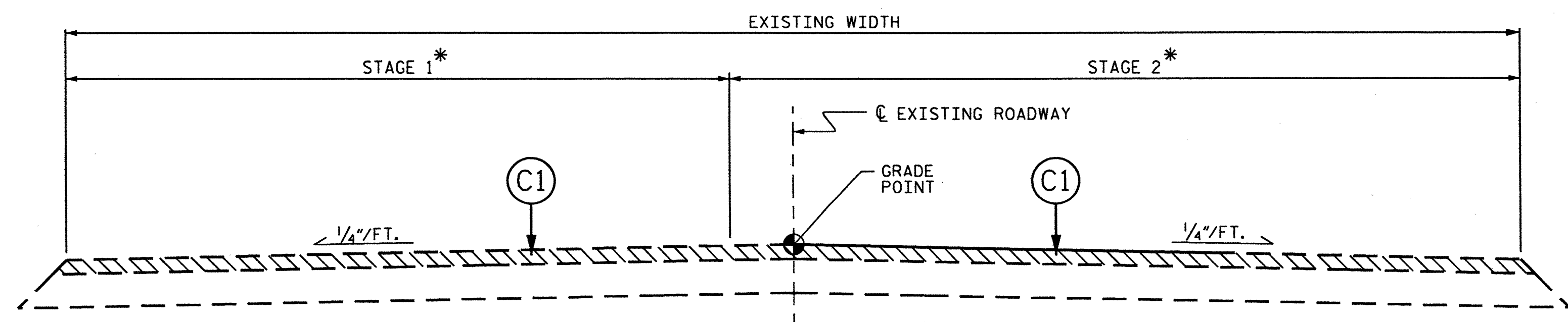

TYPICAL ROADWAY SECTION

PROJECT NO. 17BP.1.P.3
 COUNTY: BERTIE
 DECK REPAIR BRIDGE NO. 12
 SHEET 2 OF 3

STATE OF NORTH CAROLINA
 DEPARTMENT OF TRANSPORTATION
 RALEIGH
 TYPICAL ROADWAY
 SECTION AND
 MILLING DETAILS

DRAWN BY : K.H. COMPTON DATE : 9/11
 CHECKED BY : D. SNOKE DATE : 9/11

10-NOV-2011 10:08
 Z:\Squad\Deck\Division 1\Proj01.dns\DKREHAB_070012.dgn
 dmuller

NOT TO SCALE

REVISIONS						SHEET NO.
NO.	BY:	DATE:	NO.	BY:	DATE:	S-2
1			3			TOTAL SHEETS
2			4			50

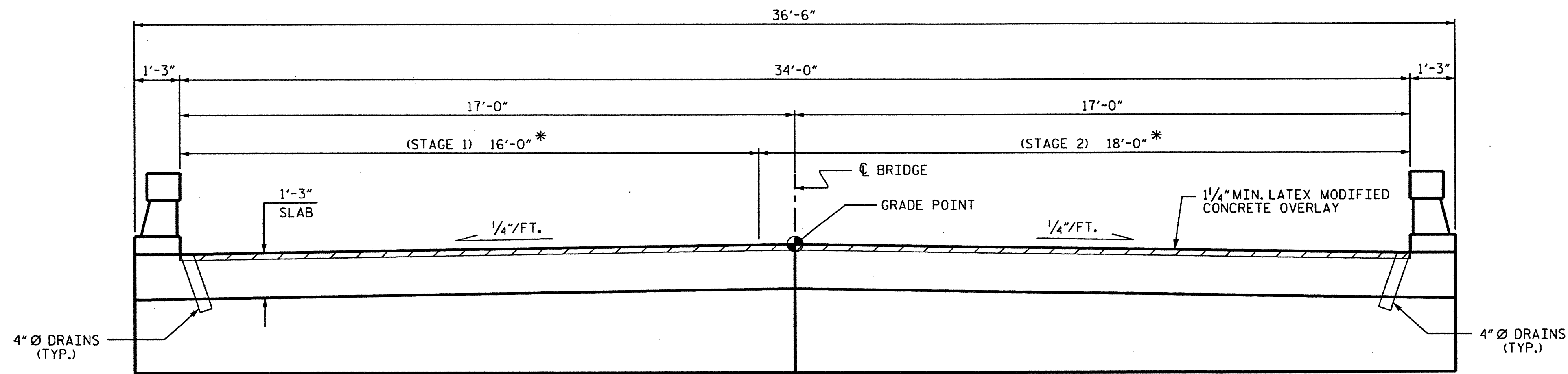

*SEE STAGING PLAN IN TRAFFIC CONTROL PLAN. SHEET ???

TYPICAL SECTION

- NOTES**
- EXISTING DECK DRAINS SHALL BE SEALED PRIOR TO BEGINNING REPAIR OF BRIDGE DECKS WITH LATEX MODIFIED CONCRETE. SEE SPECIAL PROVISIONS.
 - FOR HYDRO-DEMOLITION, SEE SPECIAL PROVISIONS.
 - THE CONTRACTOR MUST COLLECT, TREAT AND DISPOSE OF RUN-OFF WATER FROM THE HYDRO-DEMOLITION PROCESS, SEE SPECIAL PROVISIONS.
 - THE BOUNDARIES OF AREAS IDENTIFIED FOR CLASS III SURFACE PREPARATION ARE APPROXIMATE. THE CONTRACTOR SHALL PROVIDE A METHOD OF HANDLING UNEXPECTED BLOW THROUGH OF DECK. SEE DETAIL.
 - FOR OVERLAY OF BRIDGE DECKS WITH LATEX MODIFIED CONCRETE, SEE SPECIAL PROVISIONS.
 - SEE SPECIAL PROVISIONS FOR SURFACE PREPARATION.
 - EXISTING BRIDGE INFORMATION BASED ON BEST AVAILABLE DATA.
 - FOR FOAM JOINT SEAL SEE SPECIAL PROVISIONS.
 - THE INSTALLED FOAM JOINT SEAL SHALL BE WATER TIGHT.
 - NOMINAL UNCOMPRESSED SEAL WIDTH OF FOAM JOINT SEAL SHALL BE 2 1/2" AT BENTS.
 - THE CONTRACTOR WILL NOT BE PERMITTED TO FORM THE JOINT FOR THE FOAM JOINT SEAL IN LIEU OF SAWING THE JOINT

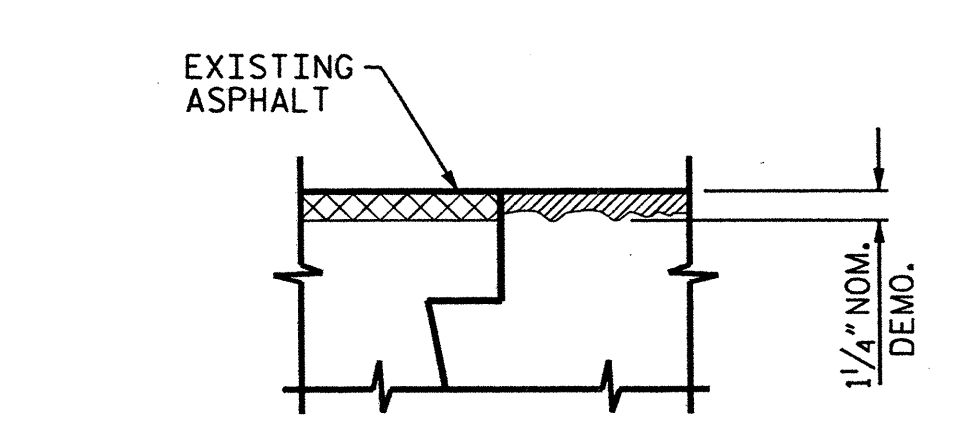

SECTION A-A
(EXISTING JOINT)

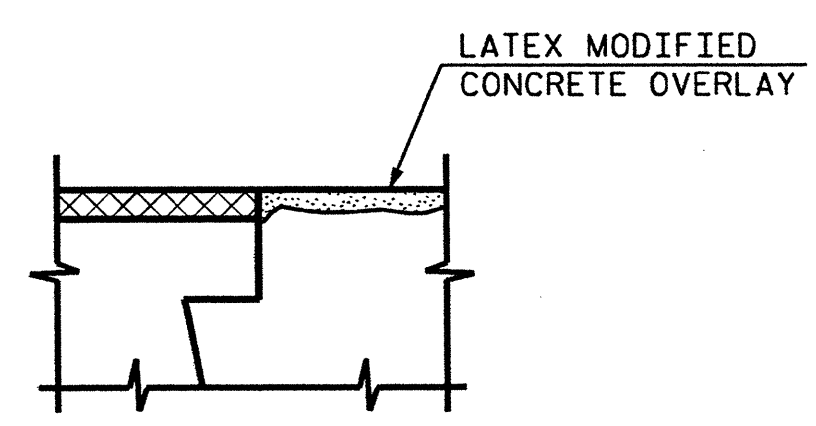

SECTION A-A
(PROPOSED JOINT)

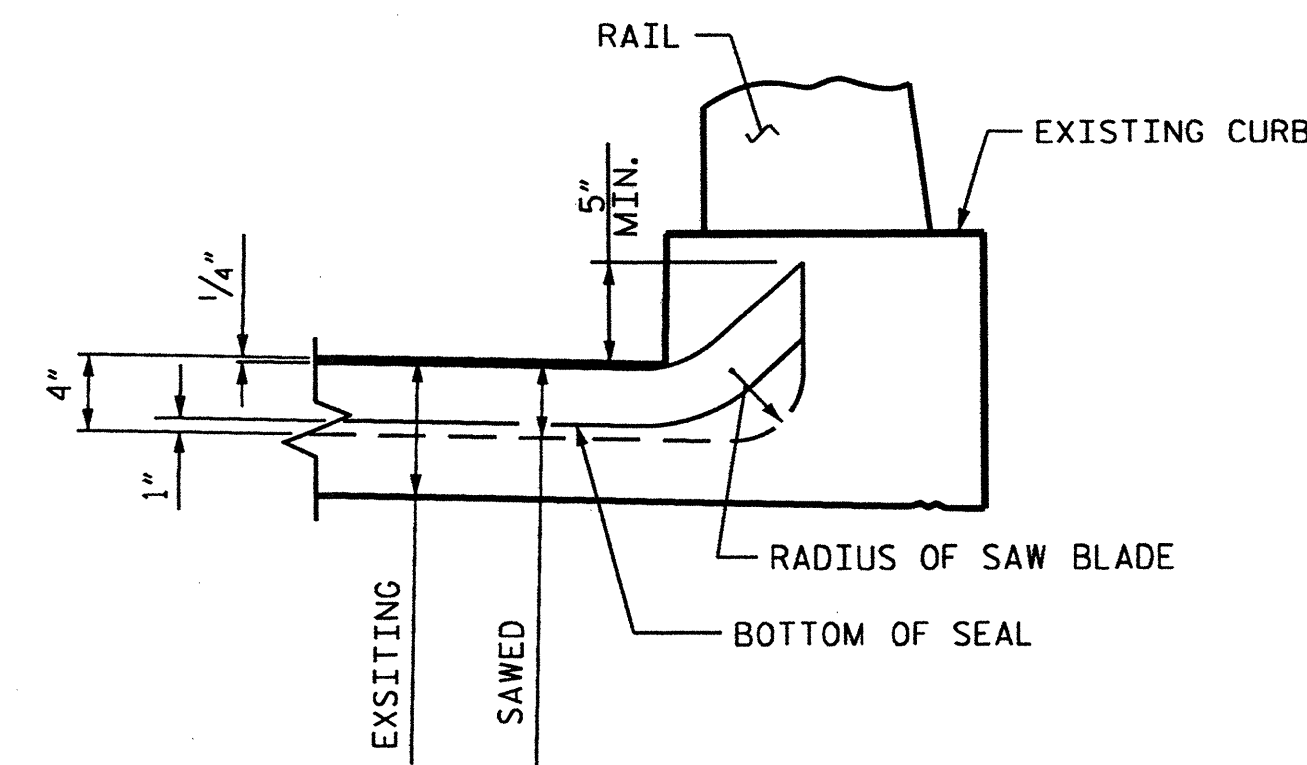

SECTION D-D

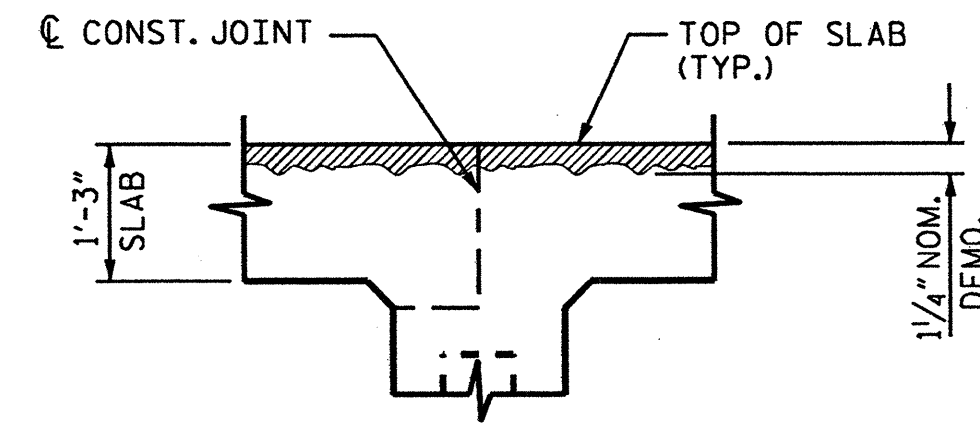

SECTION B-B
(EXISTING JOINT)

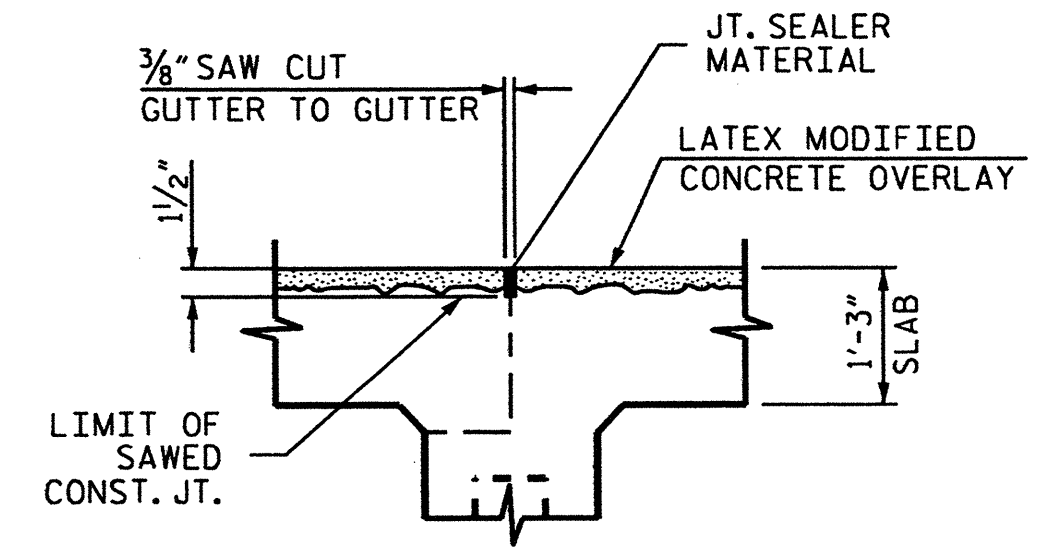

SECTION B-B
(PROPOSED JOINT)

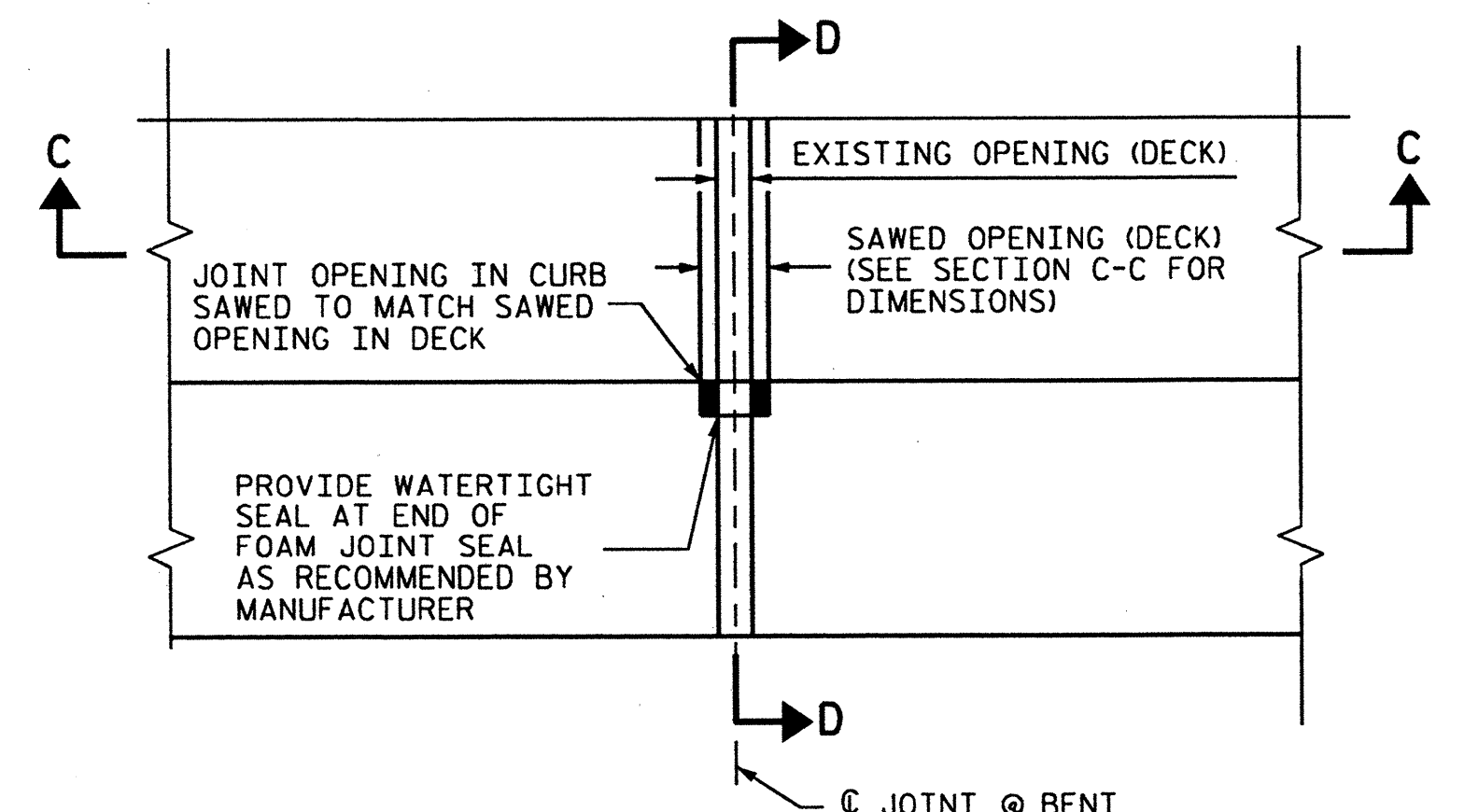

FOAM JOINT SEAL DETAILS

ELASTOMERIC CONCRETE	
BENTS	13.0 (CU. FT.)
END BENTS	0 (CU. FT.)
* TOTAL	13.0 (CU. FT.)

*BASED ON THE MINIMUM BLOCKOUT SHOWN.

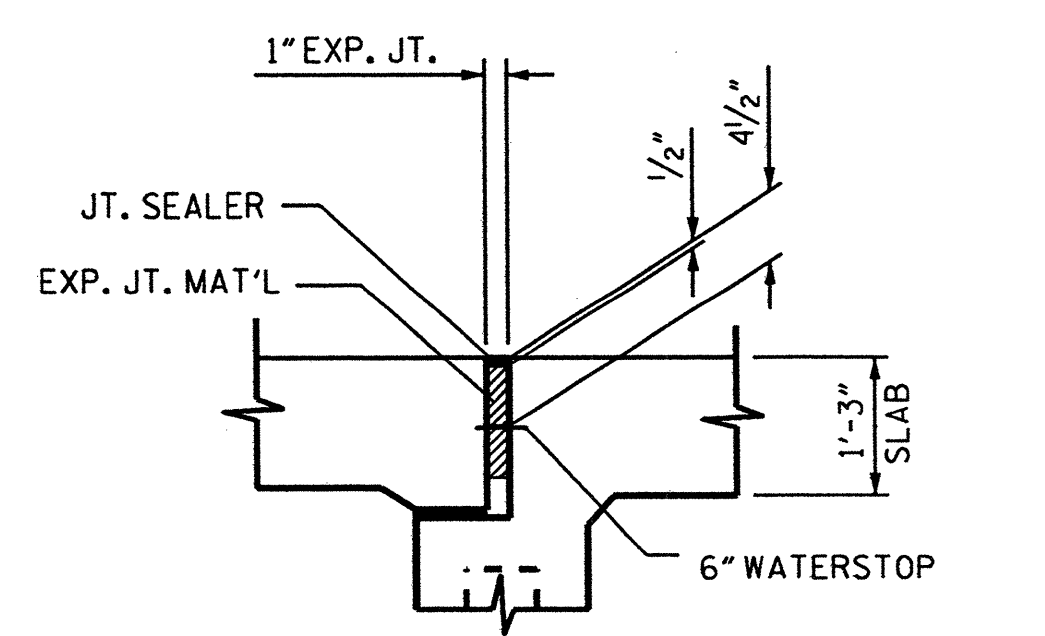

SECTION C-C
(EXISTING JOINT)

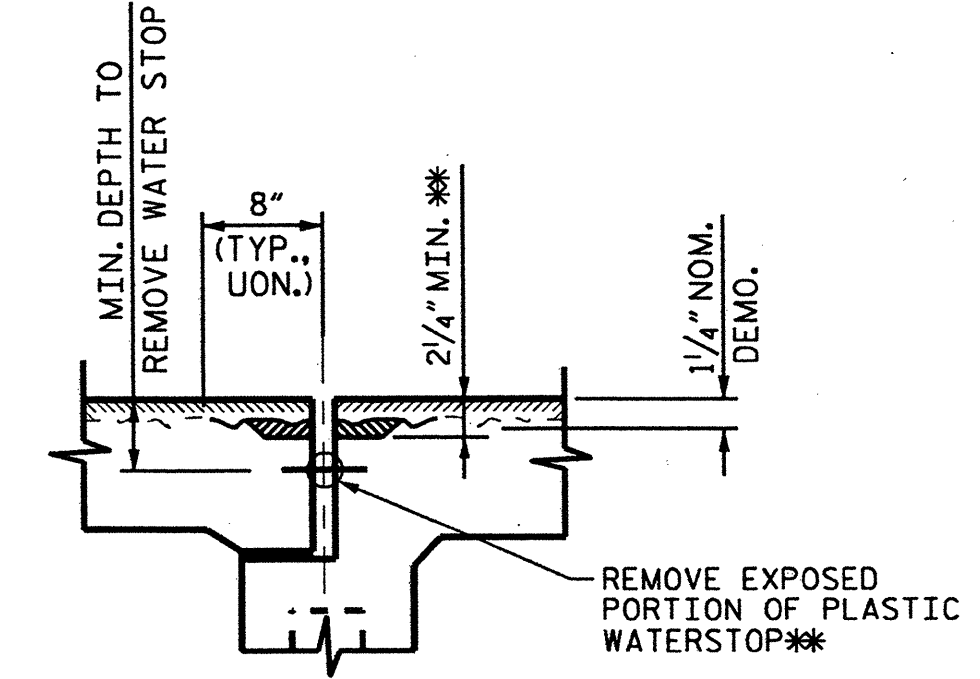

SECTION C-C
(MINIMUM EXISTING JOINT DEMOLITION)

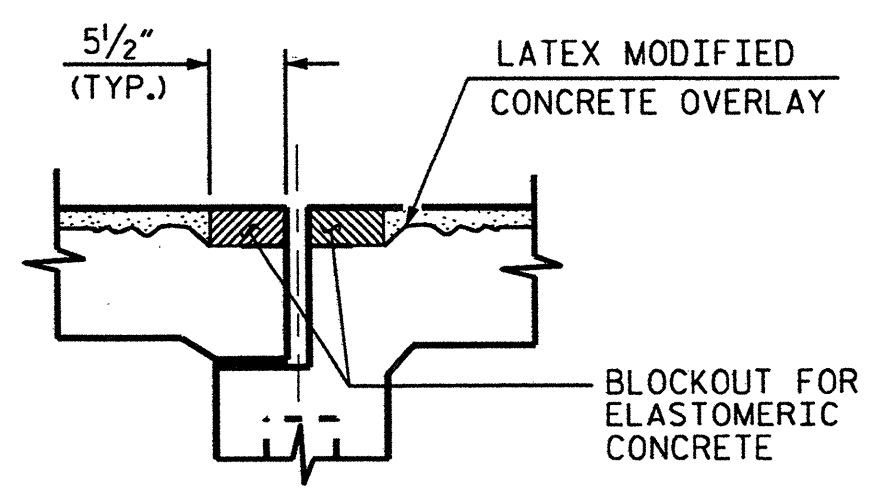

SECTION C-C
(PROPOSED FOAM JOINT SEAL PRE-SAWED DIMENSIONS)

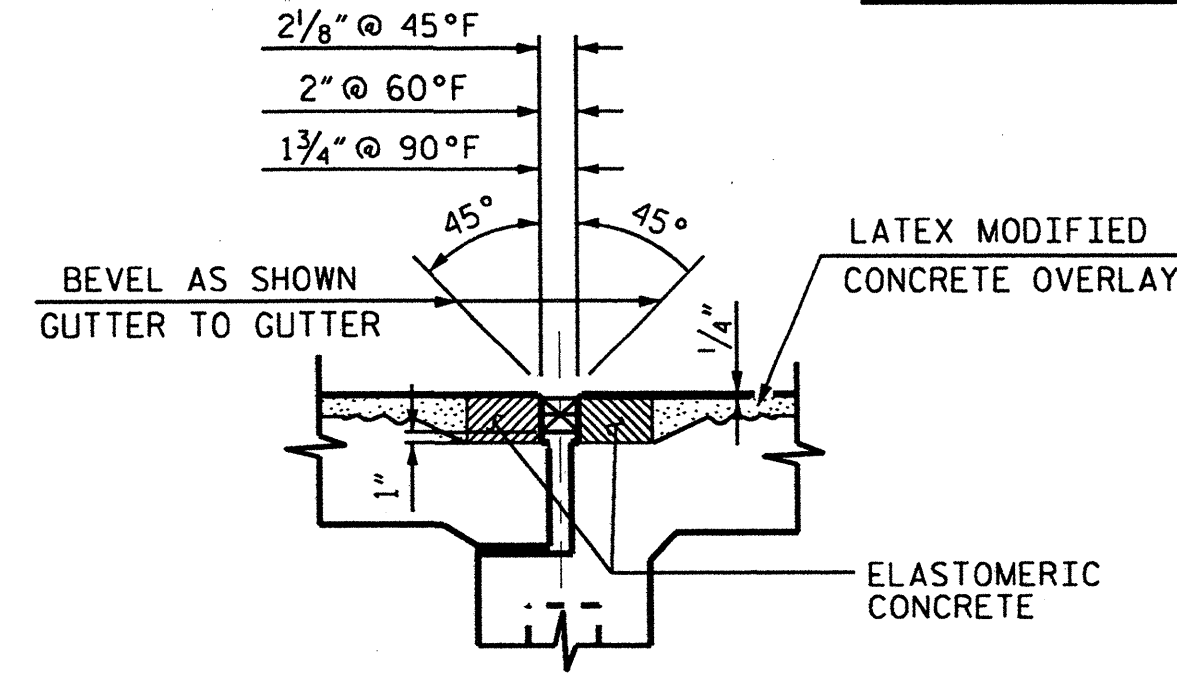

SECTION C-C
(PROPOSED FOAM JOINT SEAL EXPANSION)

** ALL LOOSE AND UNSOUND CONCRETE SHALL BE REMOVED. IF THE EMBEDDED PORTION OF THE EXISTING PLASTIC WATERSTOP IS EXPOSED DURING REMOVAL OF UNSOUND CONCRETE, THE ENTIRE WATERSTOP SHALL BE REMOVED.

PROJECT NO. 17BP.1.P.3
 COUNTY: BERTIE
 DECK REPAIR BRIDGE NO. 12
 SHEET 3 OF 3

STATE OF NORTH CAROLINA
 DEPARTMENT OF TRANSPORTATION
 RALEIGH

TYPICAL SECTION AND JOINT DETAILS

REVISIONS						SHEET NO.	
NO.	BY:	DATE:	NO.	BY:	DATE:	TOTAL SHEETS	
1			3			S-3	
2			4			50	

DRAWN BY : K.H. COMPTON DATE : 9/11
 CHECKED BY : D. SNOKE DATE : 9/11

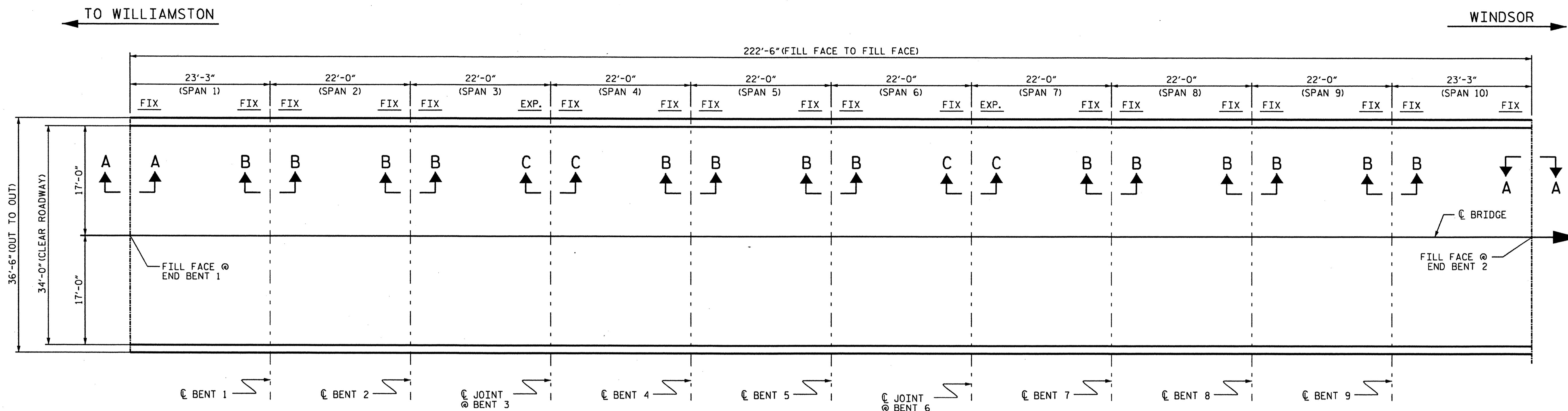

PLAN OF SPANS- DECK REPAIRS

APPROX. AREA: CLASS II REPAIR
 APPROX. AREA: CLASS III REPAIR

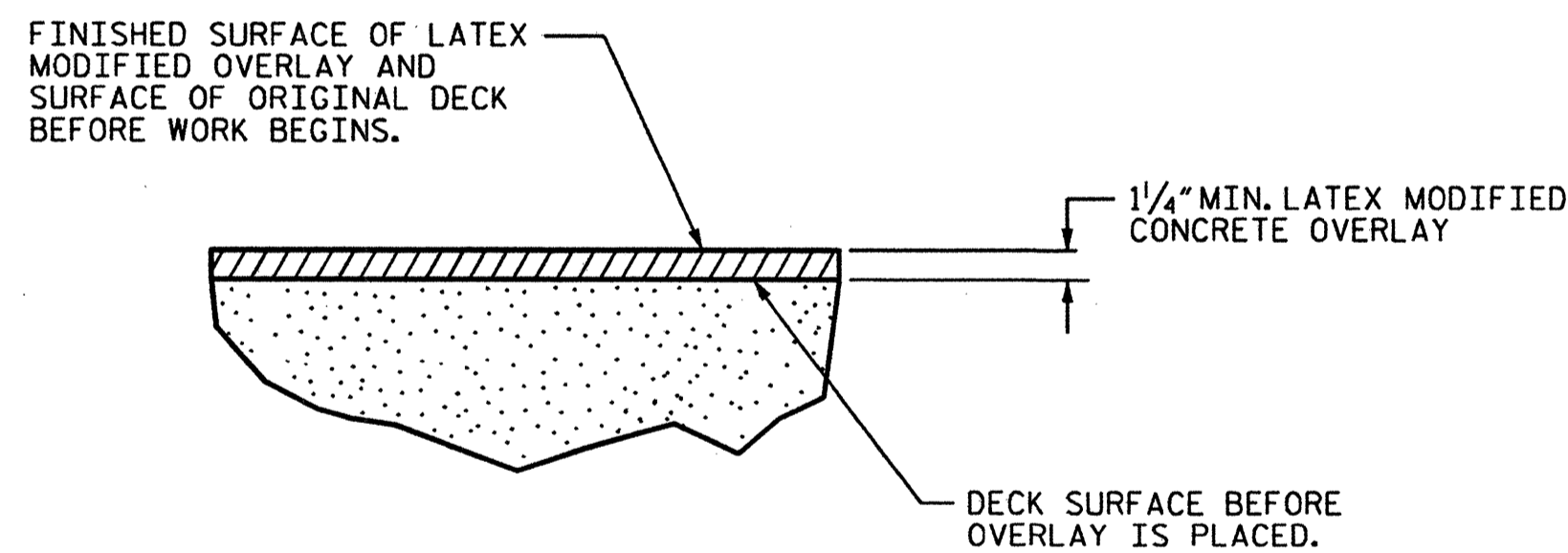

DETAIL FOR LATEX MODIFIED CONCRETE OVERLAY

TOTAL BILL OF MATERIAL									
DECK** SCARIFICATION	CLASS I* SURFACE PREPARATION	CLASS II* SURFACE PREPARATION	CLASS III* SURFACE PREPARATION	HYDRO-DEMOLITION OF BRIDGE DECK	LATEX MODIFIED CONCRETE	PLACING & FINISHING LATEX MODIFIED CONCRETE	FOAM JOINT SEALS	GROOVING BRIDGE FLOORS	ASPHALT CONC. SURF. COURSE TYPE S9.5B
SO.YDS.	SO.YDS.	SO.YDS.	SO.YDS.	SO.YDS.	C.Y.	SO.YDS.	LUMP SUM	SO. FT.	TON
985	0	0	0	841	35.0	841	LUMP SUM	6,774	13

* QUANTITIES ARE SHOWN FOR INFORMATIONAL PURPOSES ONLY. IF ANY CLASS III LOCATIONS ARE ENCOUNTERED PRIOR TO OR DURING HYDRO-DEMOLITION, SEE TYP. "BLOW THRU" CONTAINMENT AND FALSEWORK DETAILS.
 ** INCLUDES MILLING OF ROADWAY PAVEMENT.

PROJECT NO. 17BP.1.P.3
 COUNTY: BERTIE
 DECK REPAIR BRIDGE NO. 25
 SHEET 1 OF 3

STATE OF NORTH CAROLINA
DEPARTMENT OF TRANSPORTATION
RALEIGH

PLAN OF BRIDGE AND BILL OF MATERIALS

34'-0" CLEAR ROADWAY (90°-00' SKEW)

REVISIONS						SHEET NO.
NO.	BY:	DATE:	NO.	BY:	DATE:	S-4
1			3			TOTAL SHEETS
2			4			50

DRAWN BY : K.H. COMPTON DATE : 9/11
 CHECKED BY : D. SNOKE DATE : 9/11

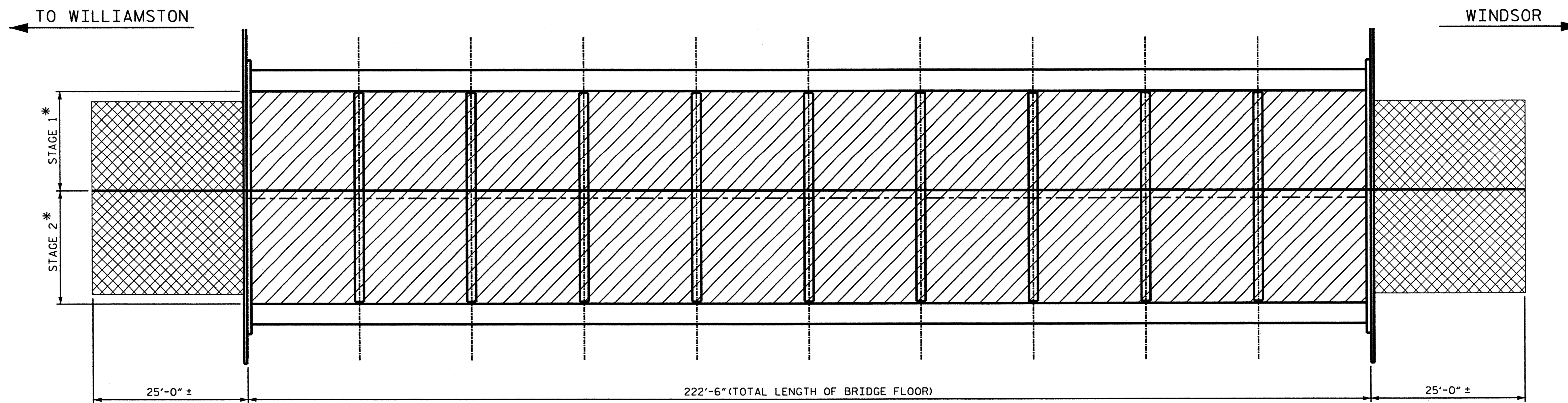

*SEE STAGING PLAN IN TRAFFIC CONTROL PLAN. SHEET TMP-4

PLAN

- DECK SCARIFICATION AND HYDRODEMOLITION
- MILLING OF ROADWAY APPROACH

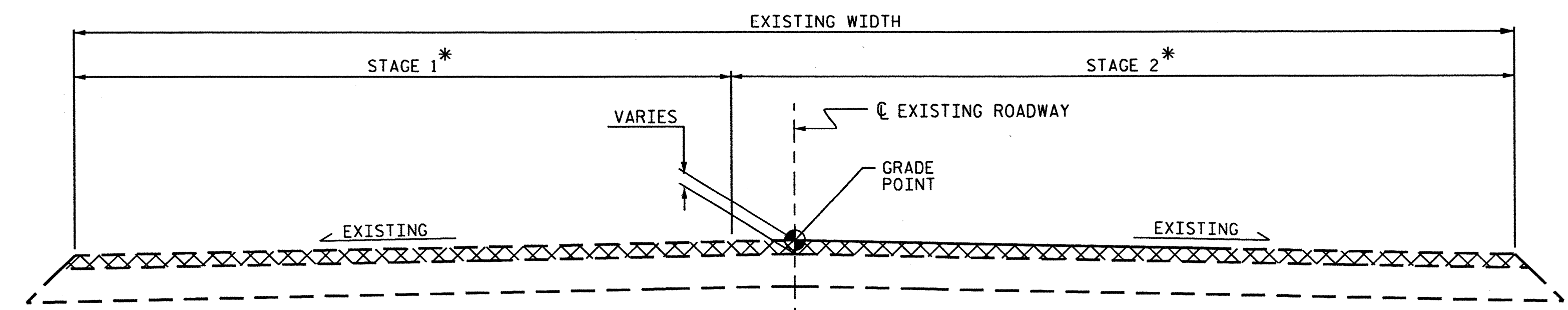

TYPICAL ROADWAY MILLING SECTION

C1 PROPOSED VARIABLE DEPTH ASPHALT CONCRETE SURFACE COURSE, TYPE SF 9.5B AT AN AVERAGE RATE OF 110 LBS. PER SQ. YD. PER 1" DEPTH. TO BE PLACED IN LAYERS NOT LESS THAN 1" IN DEPTH OR GREATER THAN 1 1/2" IN DEPTH.

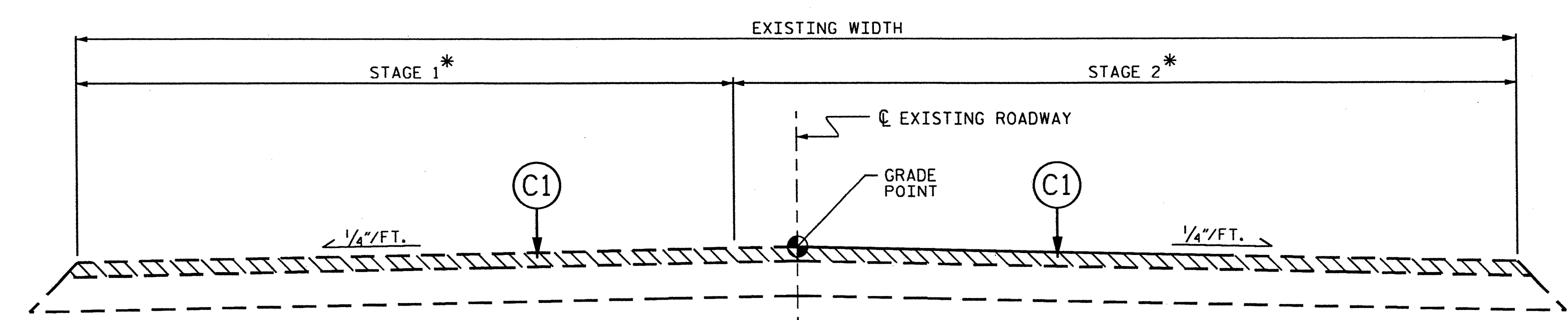

TYPICAL ROADWAY SECTION

PROJECT NO. 17BP.1.P.3
 COUNTY: BERTIE
 DECK REPAIR BRIDGE NO. 25
 SHEET 2 OF 3

STATE OF NORTH CAROLINA
 DEPARTMENT OF TRANSPORTATION
 RALEIGH

TYPICAL ROADWAY SECTION AND MILLING DETAILS

REVISIONS				SHEET NO.	
NO.	BY:	DATE:	NO.	BY:	DATE:
1			3		
2			4		

S-5
TOTAL SHEETS
50

DRAWN BY : K.H. COMPTON DATE : 9/11
 CHECKED BY : D. SNOKE DATE : 9/11

NOT TO SCALE

10-NOV-2011 10:08
 Z:\Soud\Deck\Division 1\Proj01.dns\DKREHAB_070025.dgn
 dmuller

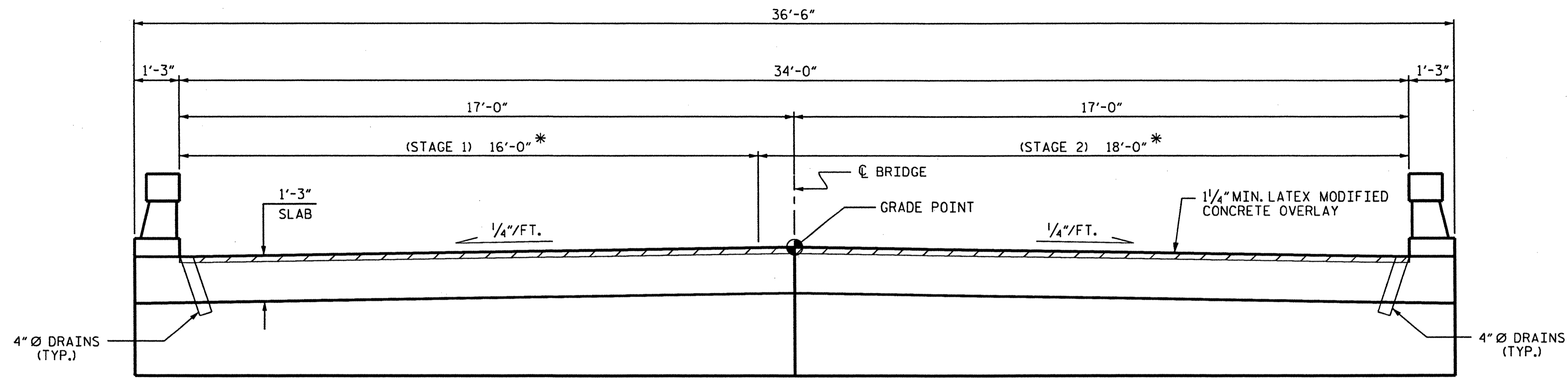

TYPICAL SECTION

*SEE STAGING PLAN IN TRAFFIC CONTROL PLAN. SHEET ???

- NOTES**
- EXISTING DECK DRAINS SHALL BE SEALED PRIOR TO BEGINNING REPAIR OF BRIDGE DECKS WITH LATEX MODIFIED CONCRETE. SEE SPECIAL PROVISIONS.
 - FOR HYDRO-DEMOLITION, SEE SPECIAL PROVISIONS.
 - THE CONTRACTOR MUST COLLECT, TREAT AND DISPOSE OF RUN-OFF WATER FROM THE HYDRO-DEMOLITION PROCESS. SEE SPECIAL PROVISIONS.
 - THE BOUNDARIES OF AREAS IDENTIFIED FOR CLASS III SURFACE PREPARATION ARE APPROXIMATE. THE CONTRACTOR SHALL PROVIDE A METHOD OF HANDLING UNEXPECTED BLOW THROUGH OF DECK. SEE DETAIL.
 - FOR OVERLAY OF BRIDGE DECKS WITH LATEX MODIFIED CONCRETE, SEE SPECIAL PROVISIONS.
 - SEE SPECIAL PROVISIONS FOR SURFACE PREPARATION.
 - EXISTING BRIDGE INFORMATION BASED ON BEST AVAILABLE DATA.
 - FOR FOAM JOINT SEAL SEE SPECIAL PROVISIONS.
 - THE INSTALLED FOAM JOINT SEAL SHALL BE WATER TIGHT.
 - NOMINAL UNCOMPRESSED SEAL WIDTH OF FOAM JOINT SEAL SHALL BE 2 1/2" AT BENTS.
 - THE CONTRACTOR WILL NOT BE PERMITTED TO FORM THE JOINT FOR THE FOAM JOINT SEAL IN LIEU OF SAWING THE JOINT

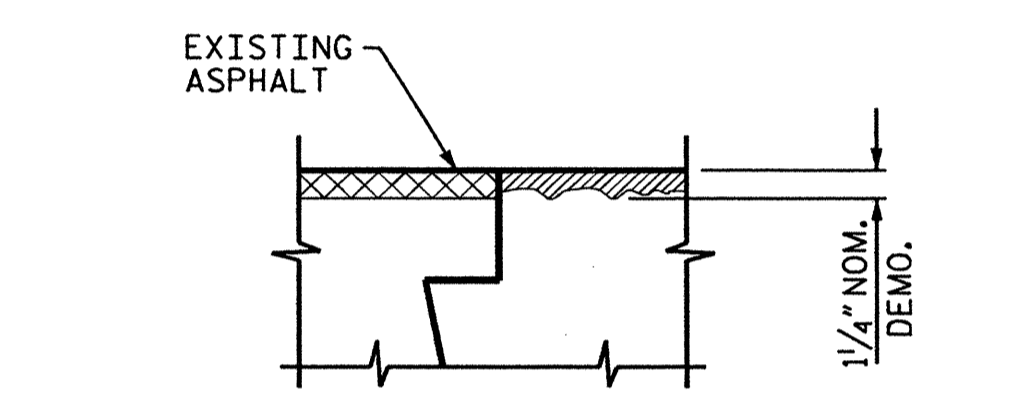

SECTION A-A
(EXISTING JOINT)

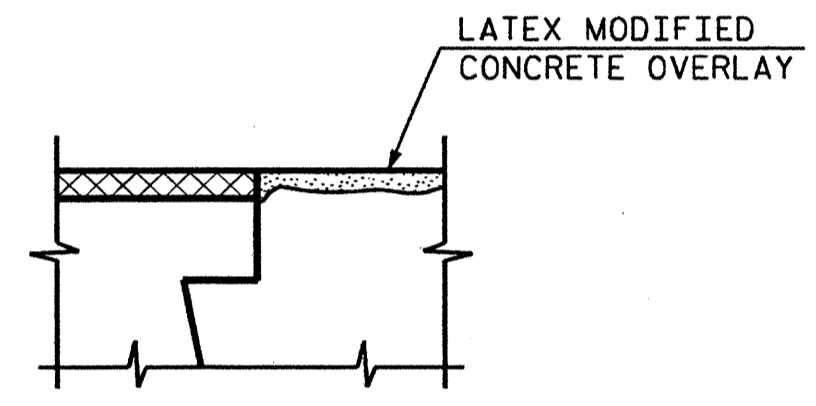

SECTION A-A
(PROPOSED JOINT)

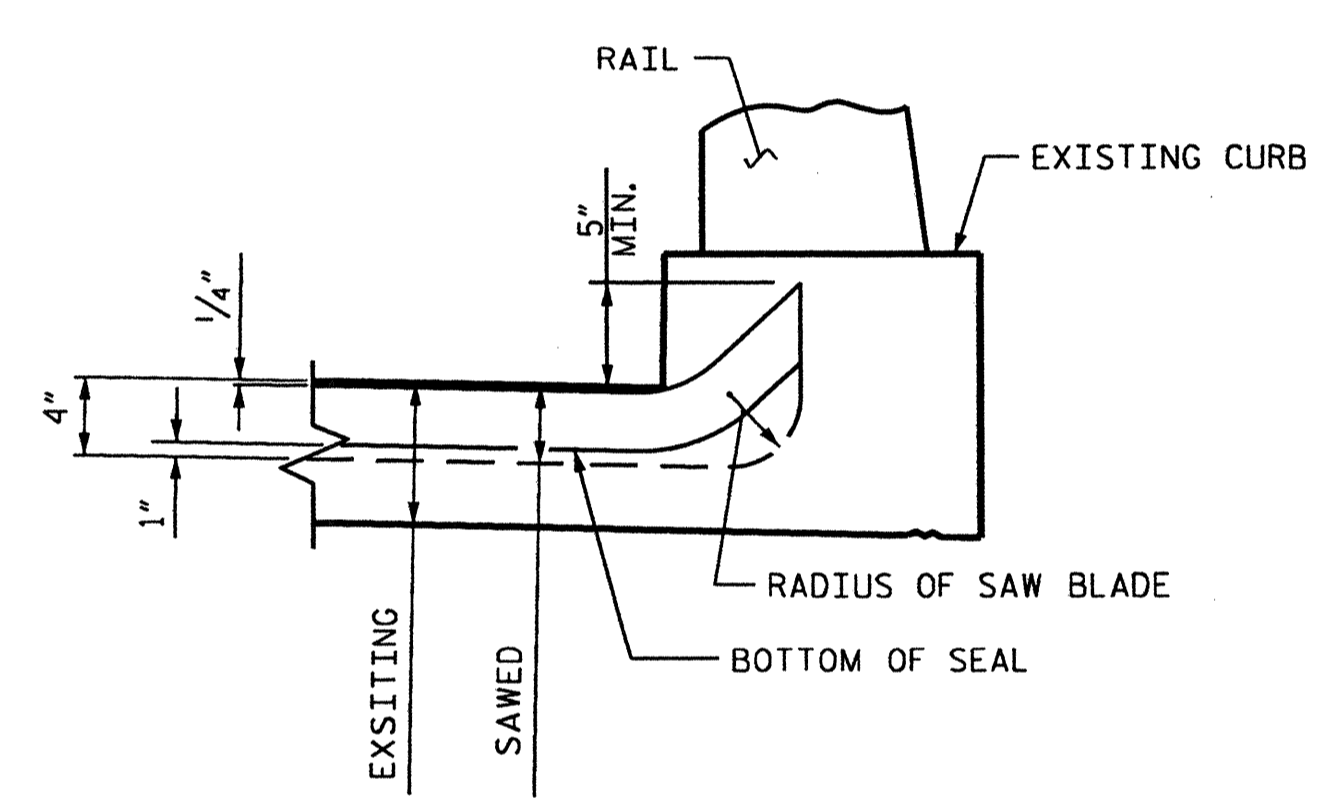

SECTION D-D

ELASTOMERIC CONCRETE	
BENTS	13.0 (CU. FT.)
END BENTS	0 (CU. FT.)
* TOTAL	13.0 (CU. FT.)

*BASED ON THE MINIMUM BLOCKOUT SHOWN.

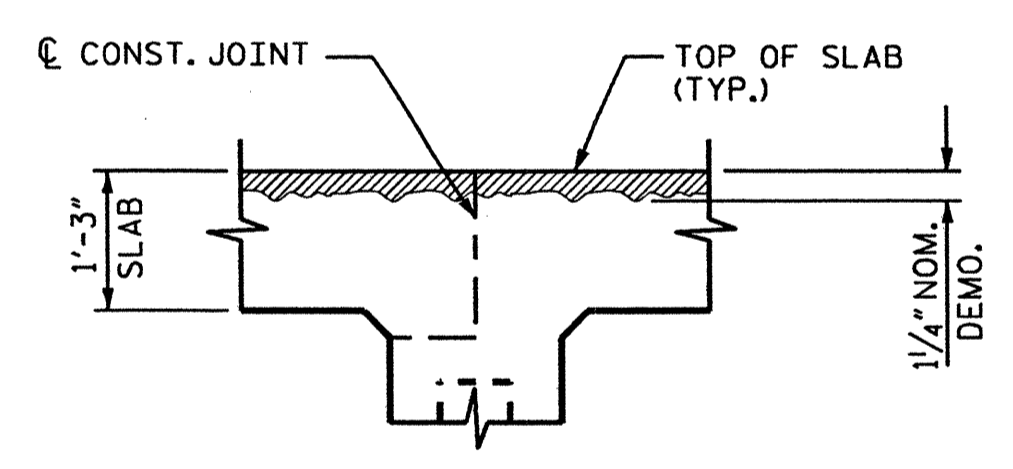

SECTION B-B
(EXISTING JOINT)

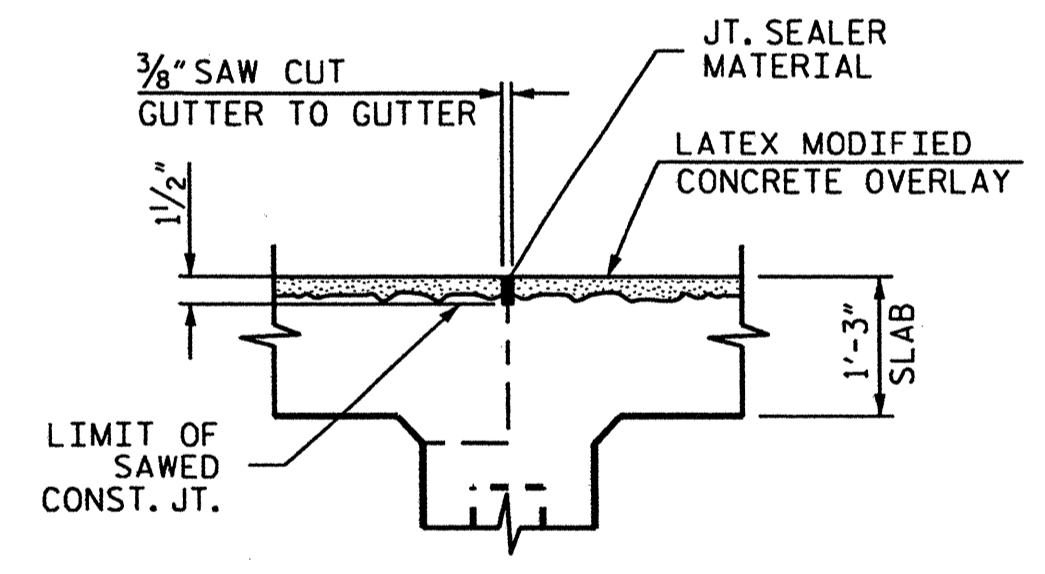

SECTION B-B
(PROPOSED JOINT)

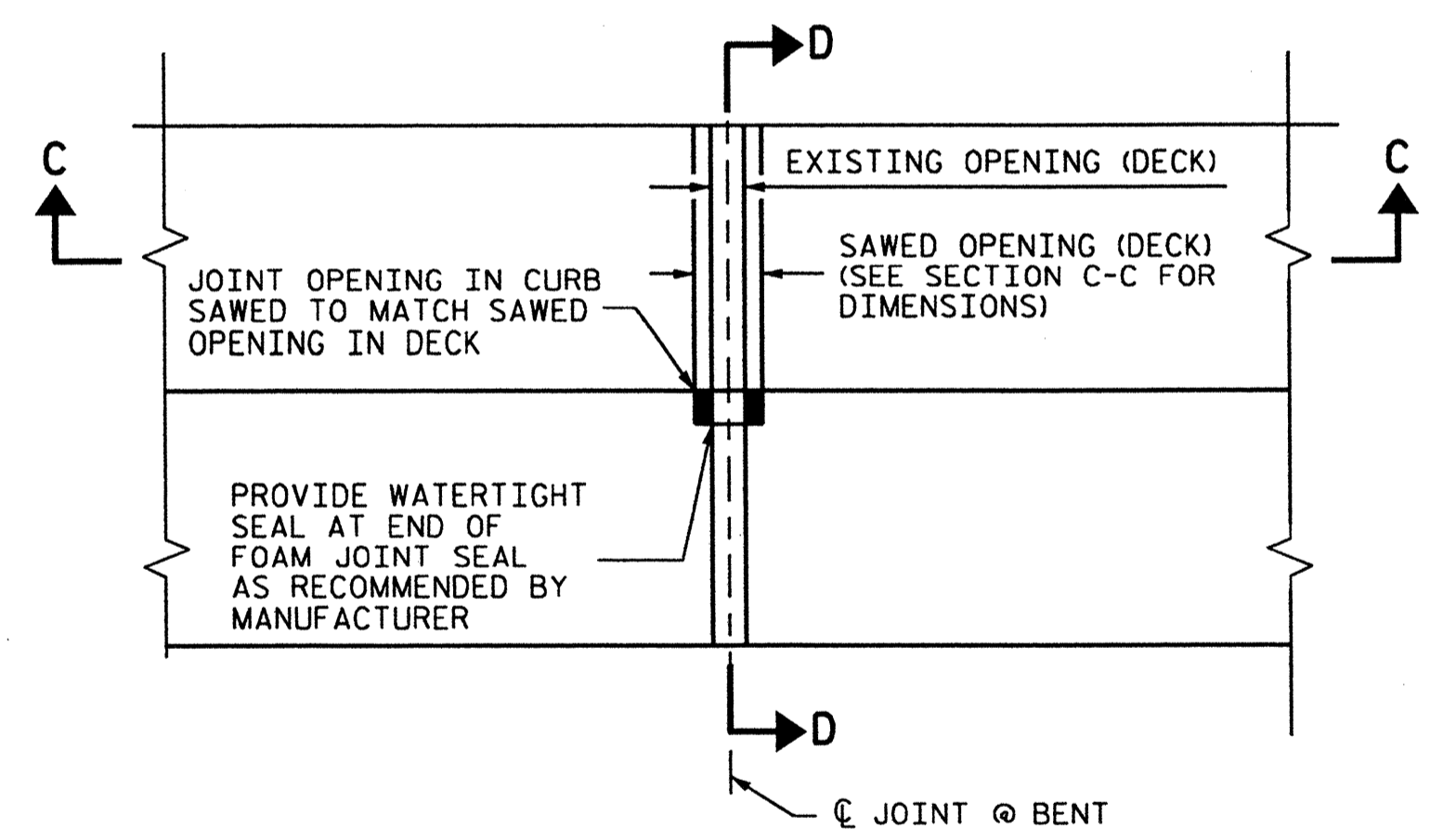

FOAM JOINT SEAL DETAILS

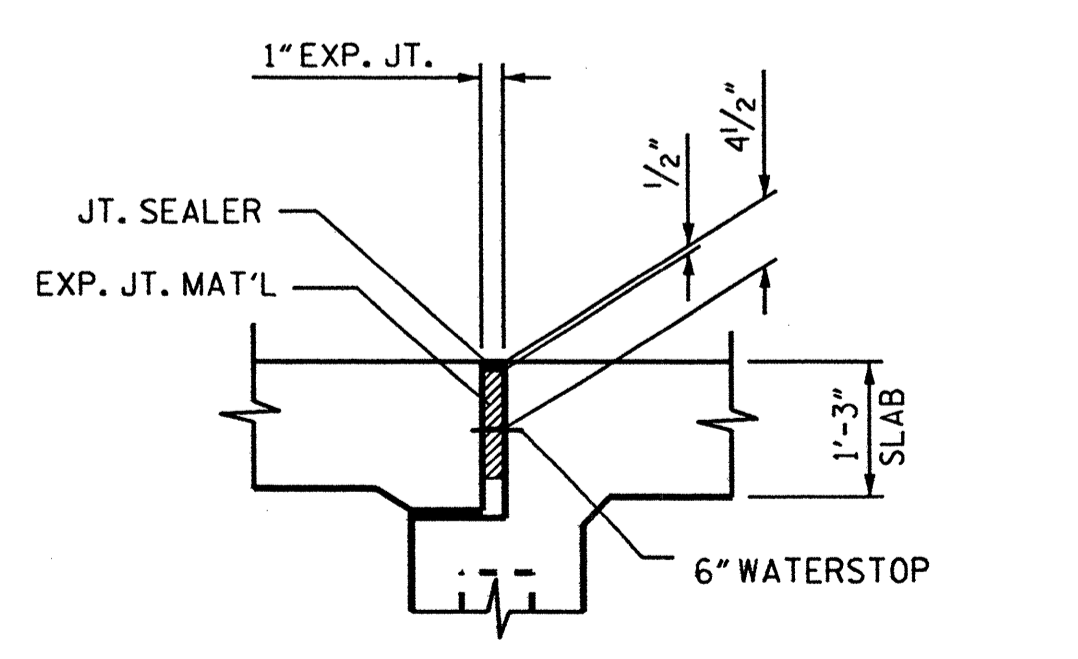

SECTION C-C
(EXISTING JOINT)

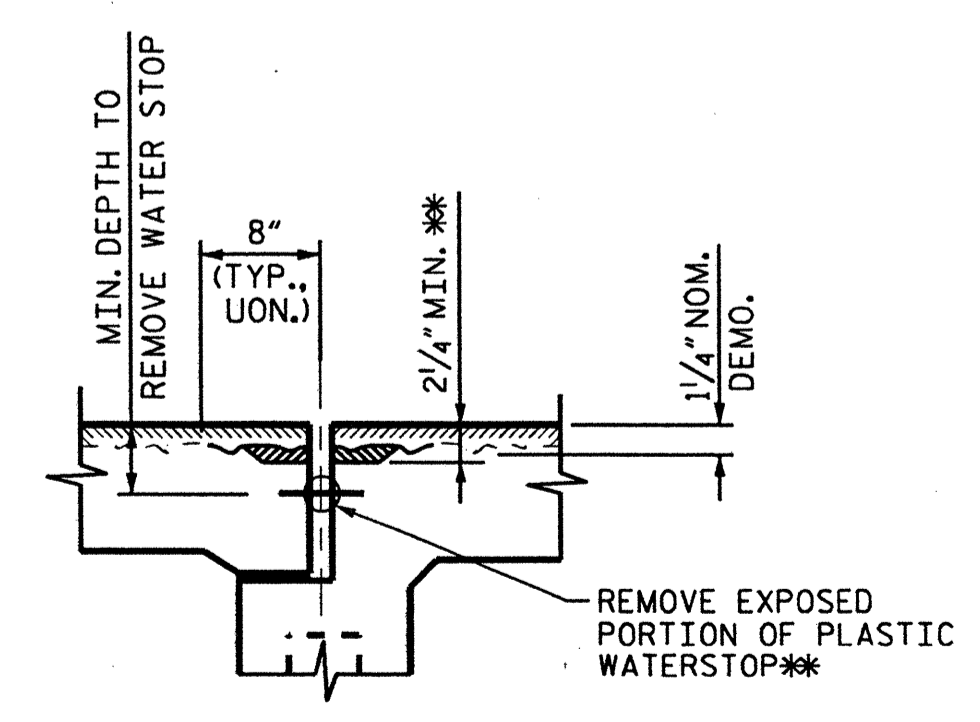

SECTION C-C
(MINIMUM EXISTING JOINT DEMOLITION)

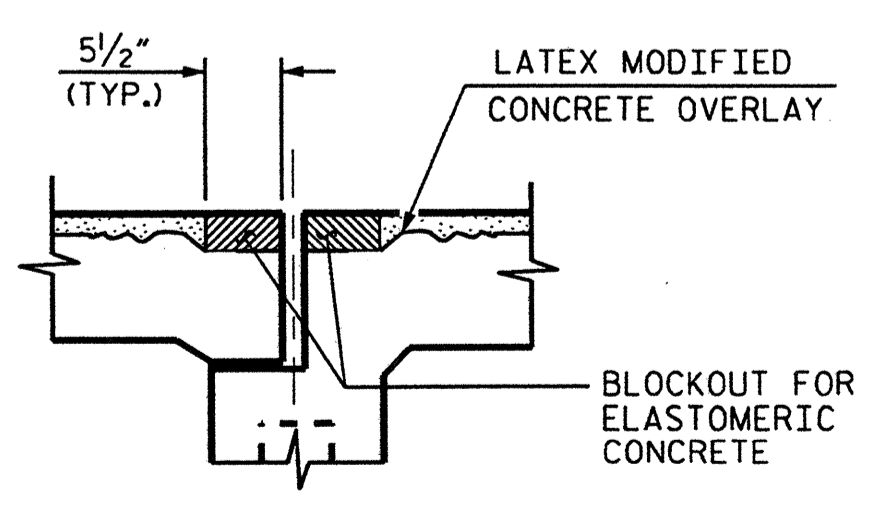

SECTION C-C
(PROPOSED FOAM JOINT SEAL PRE-SAWED DIMENSIONS)

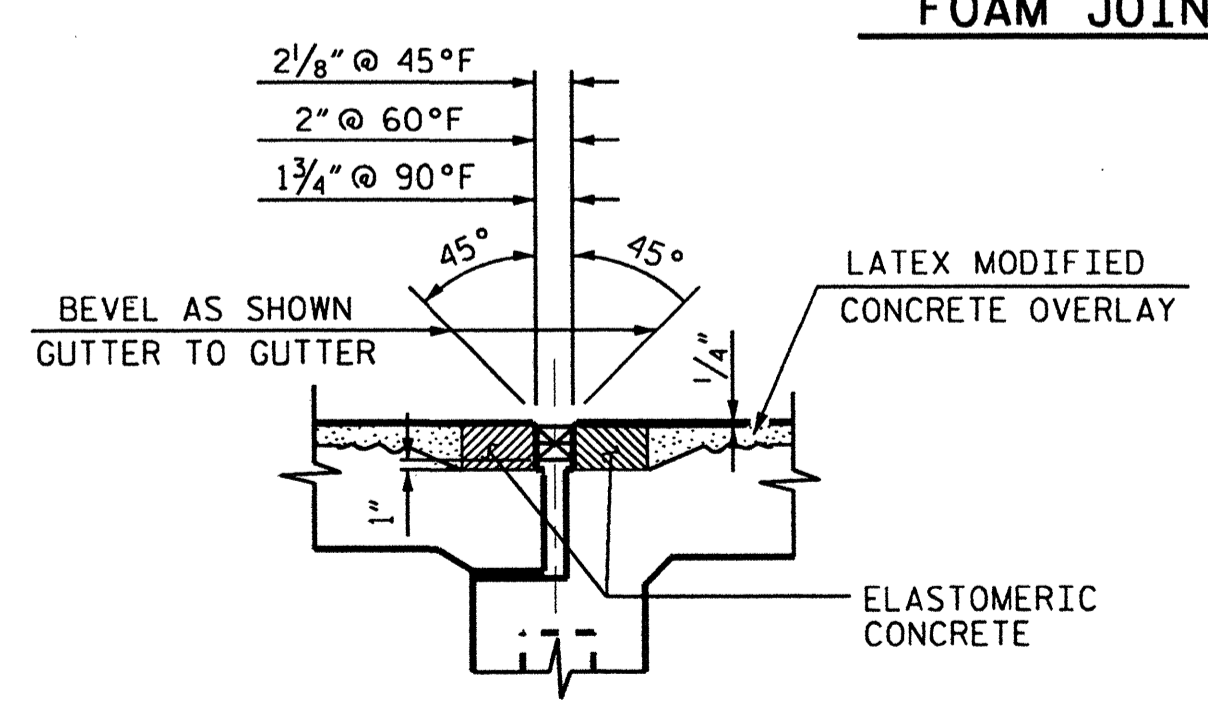

SECTION C-C
(PROPOSED FOAM JOINT SEAL EXPANSION)

** ALL LOOSE AND UNSOUND CONCRETE SHALL BE REMOVED. IF THE EMBEDDED PORTION OF THE EXISTING PLASTIC WATERSTOP IS EXPOSED DURING REMOVAL OF UNSOUND CONCRETE, THE ENTIRE WATERSTOP SHALL BE REMOVED.

PROJECT NO. 17BP.1.P.3
 COUNTY: BERTIE
 DECK REPAIR BRIDGE NO. 25
 SHEET 3 OF 3

REVISIONS						SHEET NO.
NO.	BY:	DATE:	NO.	BY:	DATE:	S-6
1			3			TOTAL SHEETS
2			4			50

DRAWN BY : K.H. COMPTON DATE : 9/11
 CHECKED BY : D. SNOKE DATE : 9/11

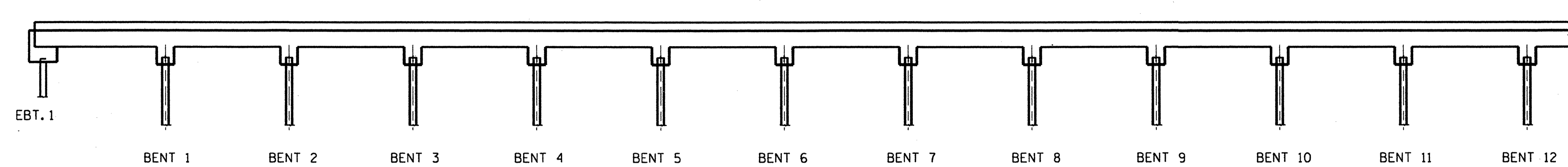

PROFILE OF BRIDGE

← WILLIAMSTON

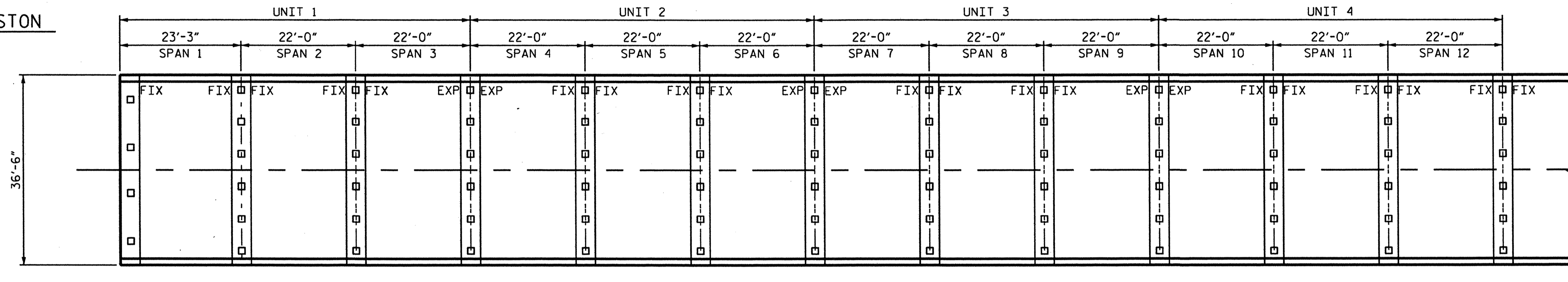

PLAN OF BRIDGE

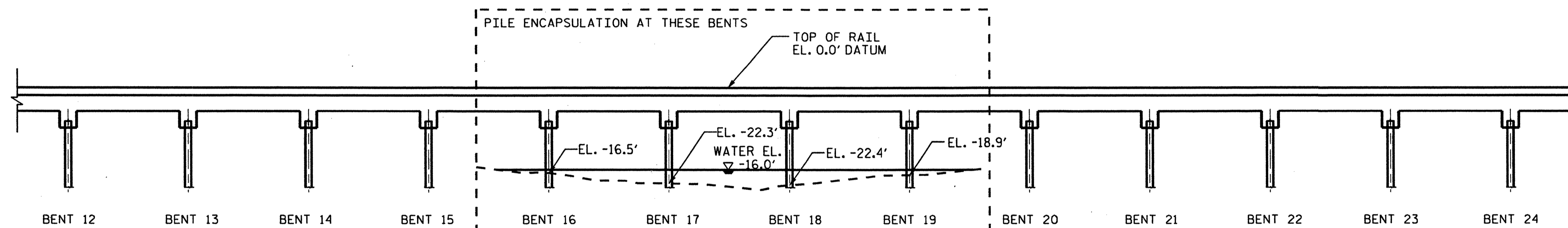

PROFILE OF BRIDGE

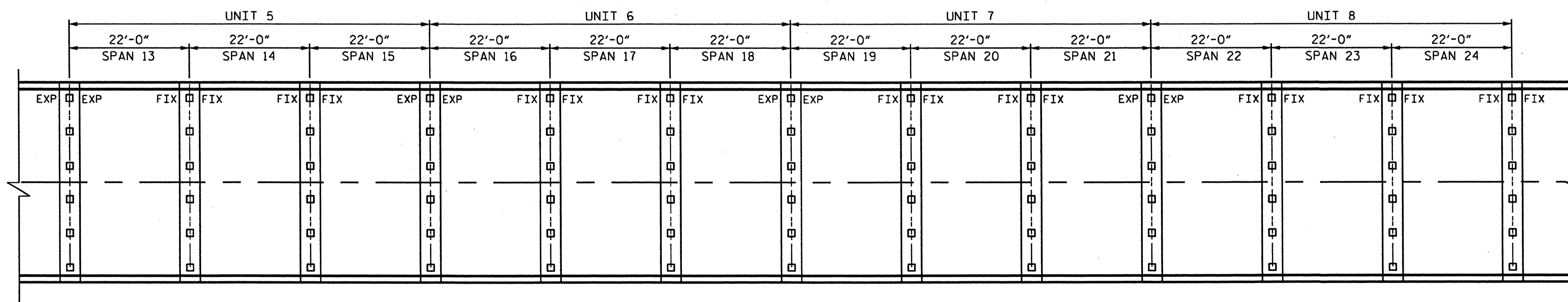

PLAN OF BRIDGE

PROJECT NO. 17BP.1.P.3
 COUNTY: BERTIE
 DECK REPAIR BRIDGE NO. 35
 SHEET 1 OF 8

STATE OF NORTH CAROLINA
 DEPARTMENT OF TRANSPORTATION
 RALEIGH

GENERAL DRAWING
 BRIDGE #35 ON US13
 OVER CONNIE CREEK

REVISIONS						SHEET NO.
NO.	BY:	DATE:	NO.	BY:	DATE:	S-7
1			3			TOTAL SHEETS
2			4			50

DRAWN BY : K.H. COMPTON DATE : 10/11
 CHECKED BY : D. SNOKE DATE : 10/11

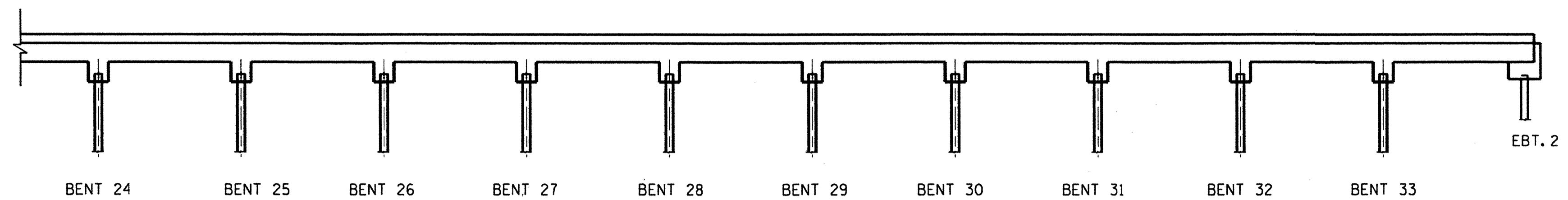

PROFILE OF BRIDGE

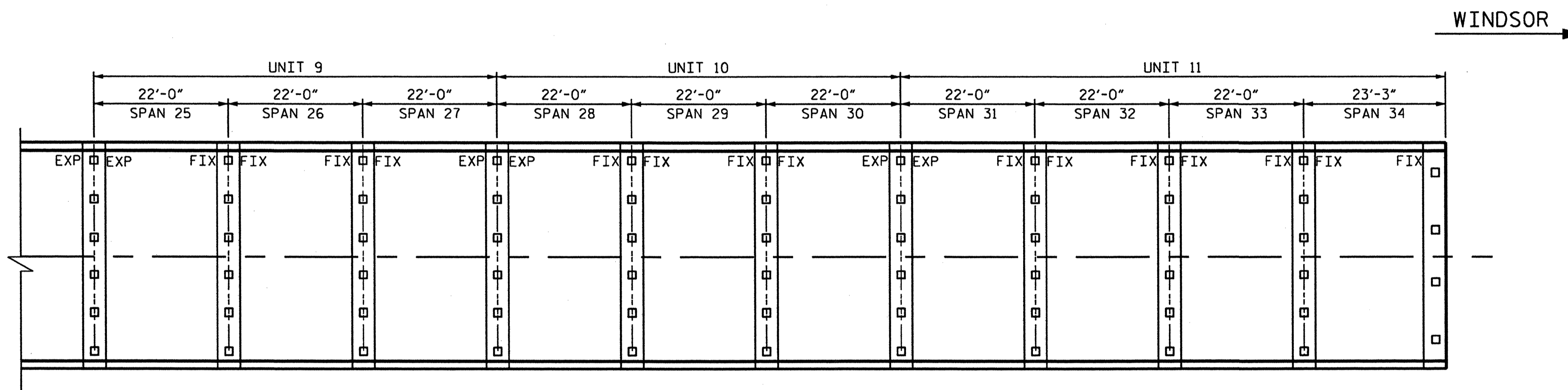

PLAN OF BRIDGE

TOTAL BILL OF MATERIAL										
DECK** SCARIFICATION	CLASS I* SURFACE PREPARATION	CLASS II* SURFACE PREPARATION	CLASS III* SURFACE PREPARATION	HYDRO- DEMOLITION OF BRIDGE DECK	LATEX MODIFIED CONCRETE	PLACING & FINISHING LATEX MODIFIED CONCRETE	FOAM JOINT SEALS	GROOVING BRIDGE FLOORS	ASPHALT CONC. SURF. COURSE TYPE S9.5B	PILE ENCAPSULATION
SO.YDS.	SO.YDS.	SO.YDS.	SO.YDS.	SO.YDS.	C.Y.	SO.YDS.	LUMP SUM	SO. FT.	TON	LF
3,013	0	24	0	2,835	98.4	2,835	LUMP SUM	22,646	16	289

* QUANTITIES ARE SHOWN FOR INFORMATIONAL PURPOSES ONLY. IF ANY CLASS III LOCATIONS ARE ENCOUNTERED PRIOR TO OR DURING HYDRO-DEMOLITION, SEE TYP. "BLOW THRU" CONTAINMENT AND FALSEWORK DETAILS.

** INCLUDES MILLING OF ROADWAY PAVEMENT.

PROJECT NO. 17BP.1.P.3
 COUNTY: BERTIE
 DECK REPAIR BRIDGE NO. 35
 SHEET 2 OF 8

STATE OF NORTH CAROLINA
 DEPARTMENT OF TRANSPORTATION
 RALEIGH

GENERAL DRAWING
 BRIDGE #35 ON US13
 OVER CONNIE CREEK

DRAWN BY : K.H. COMPTON DATE : 10/11
 CHECKED BY : D. SNOKE DATE : 10/11

10-NOV-2011 10:08
 dmuller

REVISIONS						SHEET NO.
NO.	BY:	DATE:	NO.	BY:	DATE:	TOTAL SHEETS
1			3			50
2			4			

← TO WILLIAMSTON

→ WINDSOR

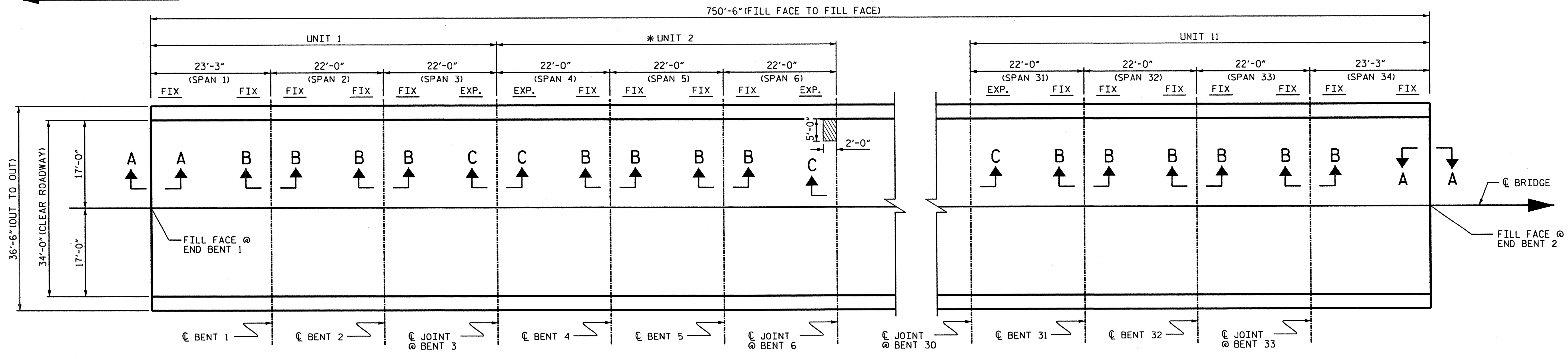

PLAN OF SPANS- DECK REPAIRS

* UNITS 2-10 SIMILAR EXCEPT CLASS II REPAIR ONLY AT LOCATIONS SHOWN. (SPANS 6, 21, 24)

APPROX. AREA: CLASS II REPAIR
 APPROX. AREA: CLASS III REPAIR

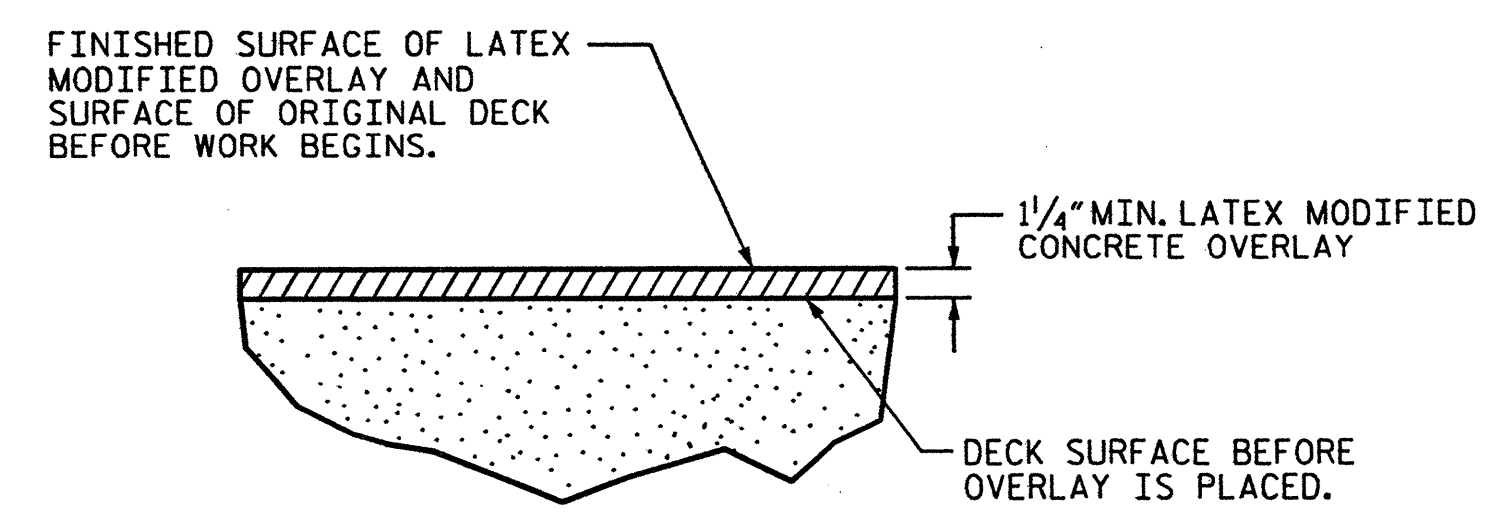

DETAIL FOR LATEX MODIFIED CONCRETE OVERLAY

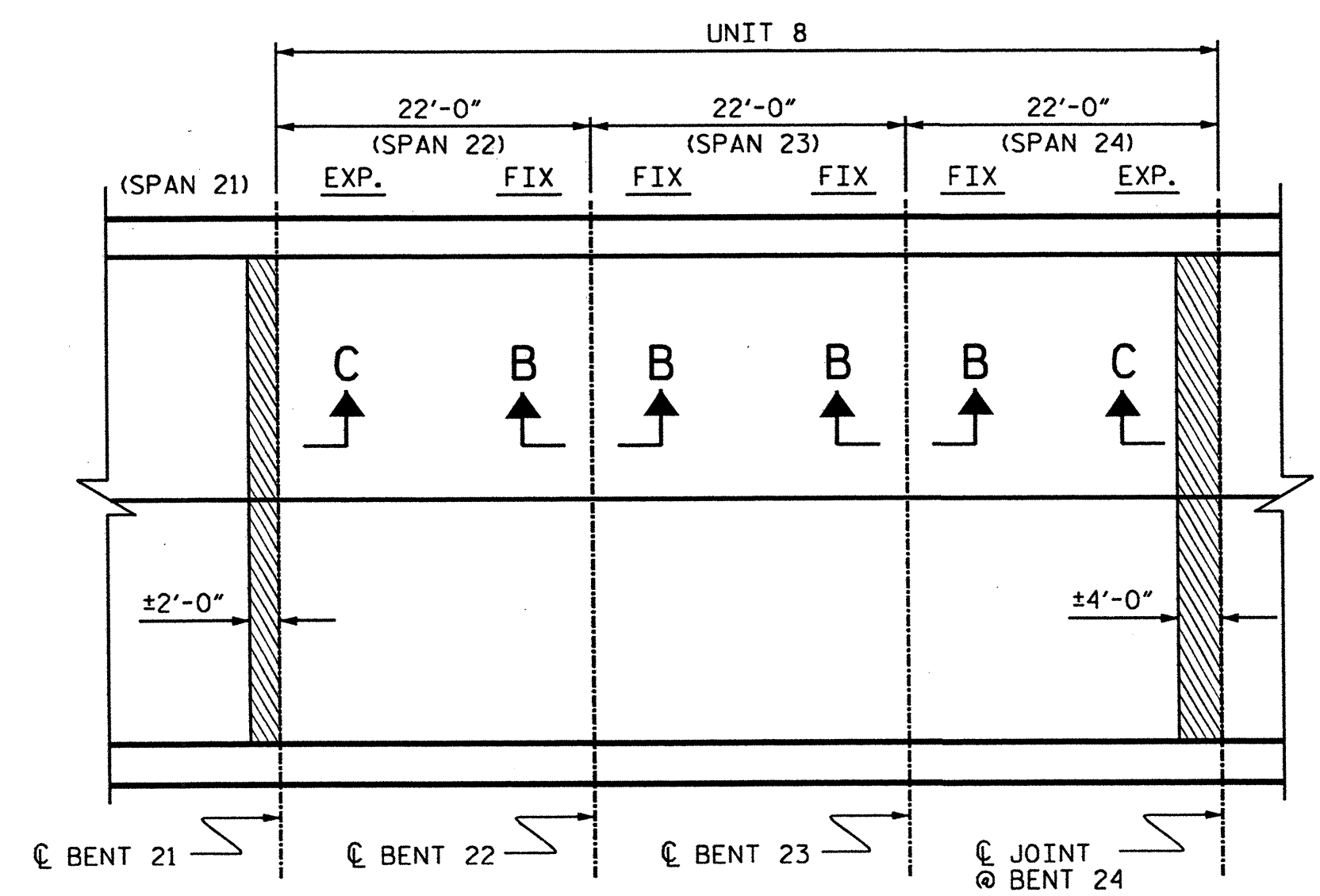

PROJECT NO. 17BP.1.P.3
 COUNTY: BERTIE
 DECK REPAIR BRIDGE NO. 35
 SHEET 3 OF 8

STATE OF NORTH CAROLINA
 DEPARTMENT OF TRANSPORTATION
 RALEIGH

PLAN OF BRIDGE

34'-0" CLEAR ROADWAY (90°-00' SKEW)

REVISIONS						SHEET NO.
NO.	BY:	DATE:	NO.	BY:	DATE:	S-9
1			3			TOTAL SHEETS
2			4			50

DRAWN BY : K.H. COMPTON DATE : 9/11
 CHECKED BY : D. SNOKE DATE : 9/11

10-NOV-2011 10:08
 Z:\Squad C\Deck\Division 1\Proj01.dns\DKREHAB.070035.dgn
 dmluler

TO WILLIAMSTON

WINDSOR

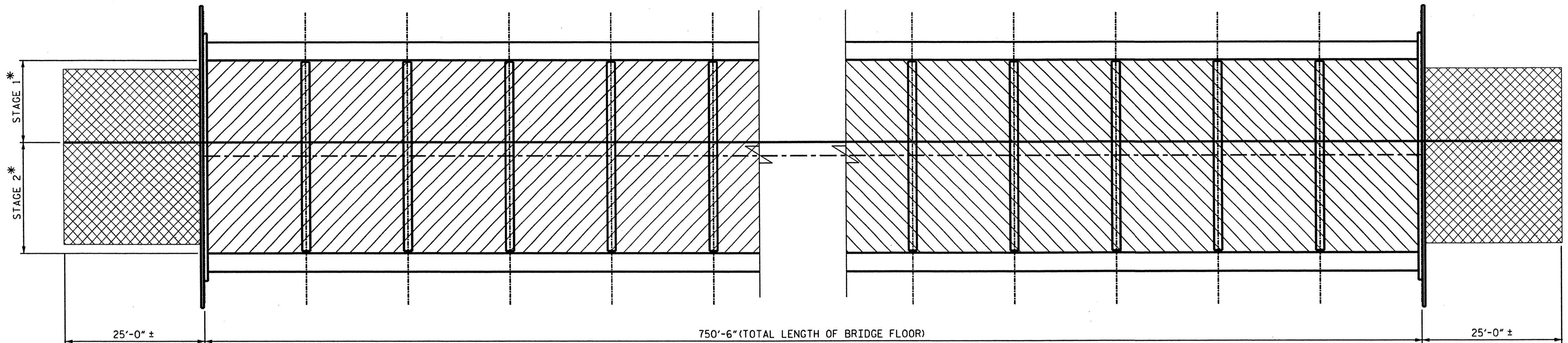

*SEE STAGING PLAN IN TRAFFIC CONTROL PLAN, SHEET TMP-4

PLAN

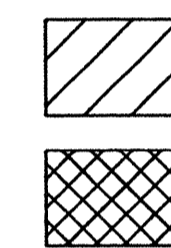

DECK SCARIFICATION AND HYDRODEMOLITION

MILLING OF ROADWAY APPROACH

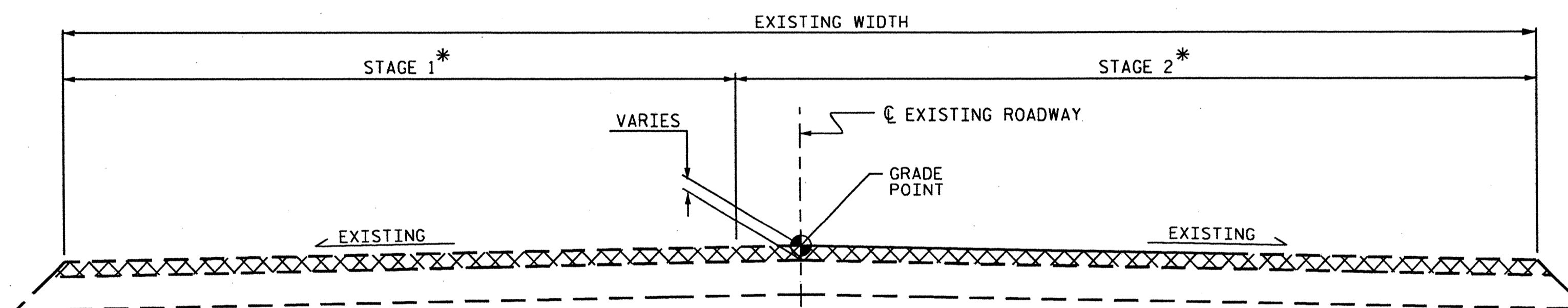

TYPICAL ROADWAY MILLING SECTION

C1 PROPOSED VARIABLE DEPTH ASPHALT CONCRETE SURFACE COURSE, TYPE SF 9.5B AT AN AVERAGE RATE OF 110 LBS. PER SQ. YD. PER 1" DEPTH, TO BE PLACED IN LAYERS NOT LESS THAN 1" IN DEPTH OR GREATER THAN 1 1/2" IN DEPTH.

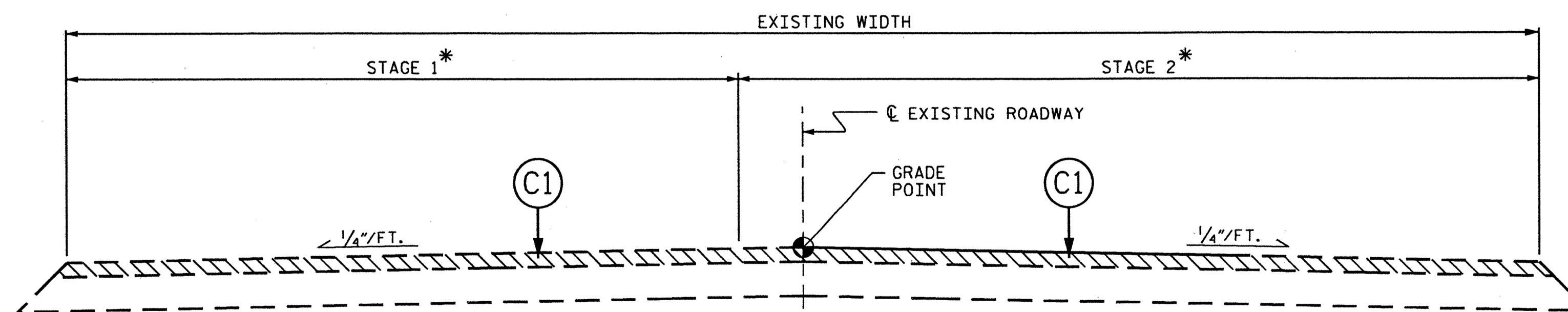

TYPICAL ROADWAY SECTION

PROJECT NO. 17BP.1.P.3
 COUNTY: BERTIE
 DECK REPAIR BRIDGE NO. 35
 SHEET 4 OF 8

STATE OF NORTH CAROLINA
 DEPARTMENT OF TRANSPORTATION
 RALEIGH
 TYPICAL ROADWAY
 SECTION AND
 MILLING DETAILS

REVISIONS						SHEET NO.
NO.	BY:	DATE:	NO.	BY:	DATE:	S-10
1			3			TOTAL SHEETS
2			4			50

DRAWN BY : K.H. COMPTON DATE : 9/11
 CHECKED BY : D. SNOKE DATE : 9/11

NOT TO SCALE

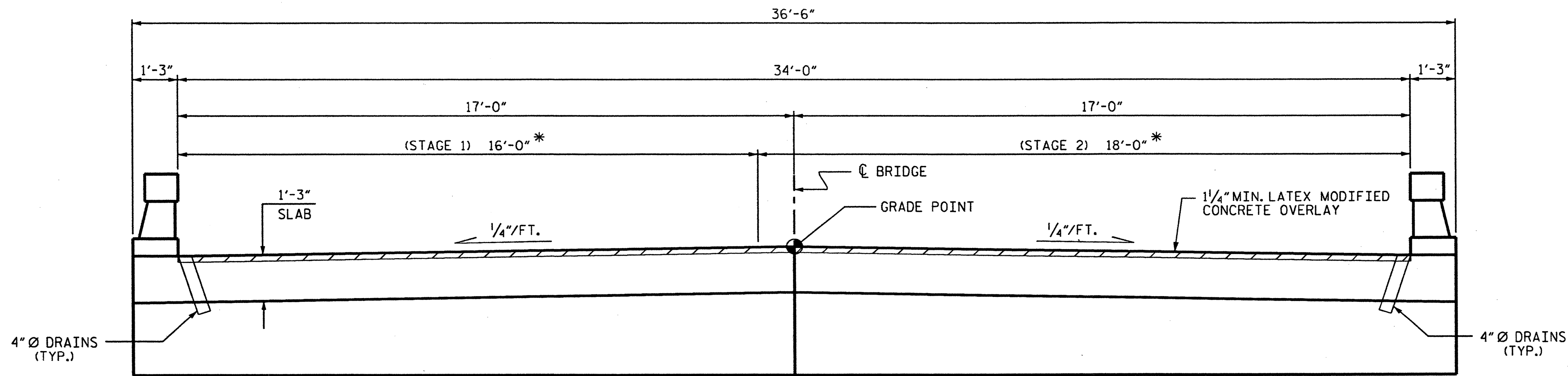

TYPICAL SECTION

* SEE STAGING PLAN IN TRAFFIC CONTROL PLAN, SHEET TMP-4

- NOTES**
- EXISTING DECK DRAINS SHALL BE SEALED PRIOR TO BEGINNING REPAIR OF BRIDGE DECKS WITH LATEX MODIFIED CONCRETE. SEE SPECIAL PROVISIONS.
 - FOR HYDRO-DEMOLITION, SEE SPECIAL PROVISIONS.
 - THE CONTRACTOR MUST COLLECT, TREAT AND DISPOSE OF RUN-OFF WATER FROM THE HYDRO-DEMOLITION PROCESS, SEE SPECIAL PROVISIONS.
 - THE BOUNDARIES OF AREAS IDENTIFIED FOR CLASS III SURFACE PREPARATION ARE APPROXIMATE. THE CONTRACTOR SHALL PROVIDE A METHOD OF HANDLING UNEXPECTED BLOW THROUGH OF DECK. SEE DETAIL.
 - FOR OVERLAY OF BRIDGE DECKS WITH LATEX MODIFIED CONCRETE, SEE SPECIAL PROVISIONS.
 - SEE SPECIAL PROVISIONS FOR SURFACE PREPARATION.
 - EXISTING BRIDGE INFORMATION BASED ON BEST AVAILABLE DATA.
 - FOR FOAM JOINT SEAL SEE SPECIAL PROVISIONS.
 - THE INSTALLED FOAM JOINT SEAL SHALL BE WATER TIGHT.
 - NOMINAL UNCOMPRESSED SEAL WIDTH OF FOAM JOINT SEAL SHALL BE 2 1/2" AT BENTS.
 - THE CONTRACTOR WILL NOT BE PERMITTED TO FORM THE JOINT FOR THE FOAM JOINT SEAL IN LIEU OF SAWING THE JOINT

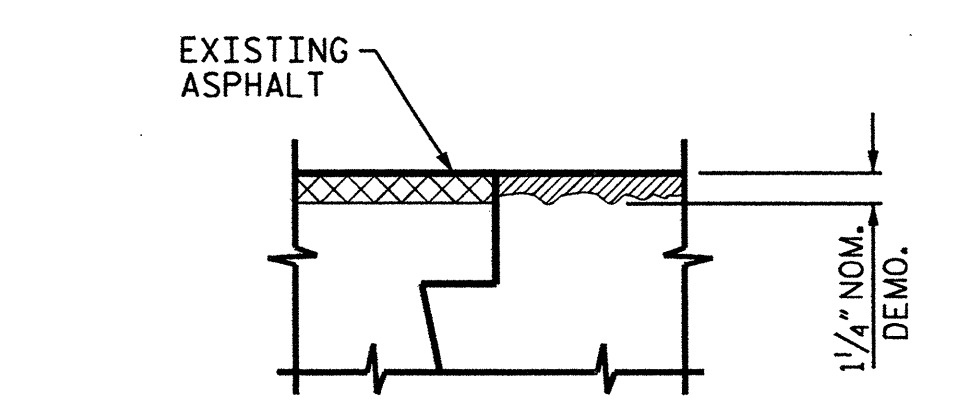

SECTION A-A (EXISTING JOINT)

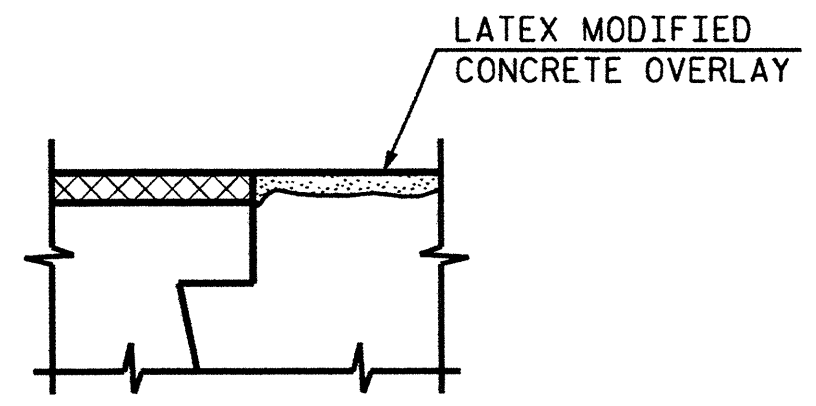

SECTION A-A (PROPOSED JOINT)

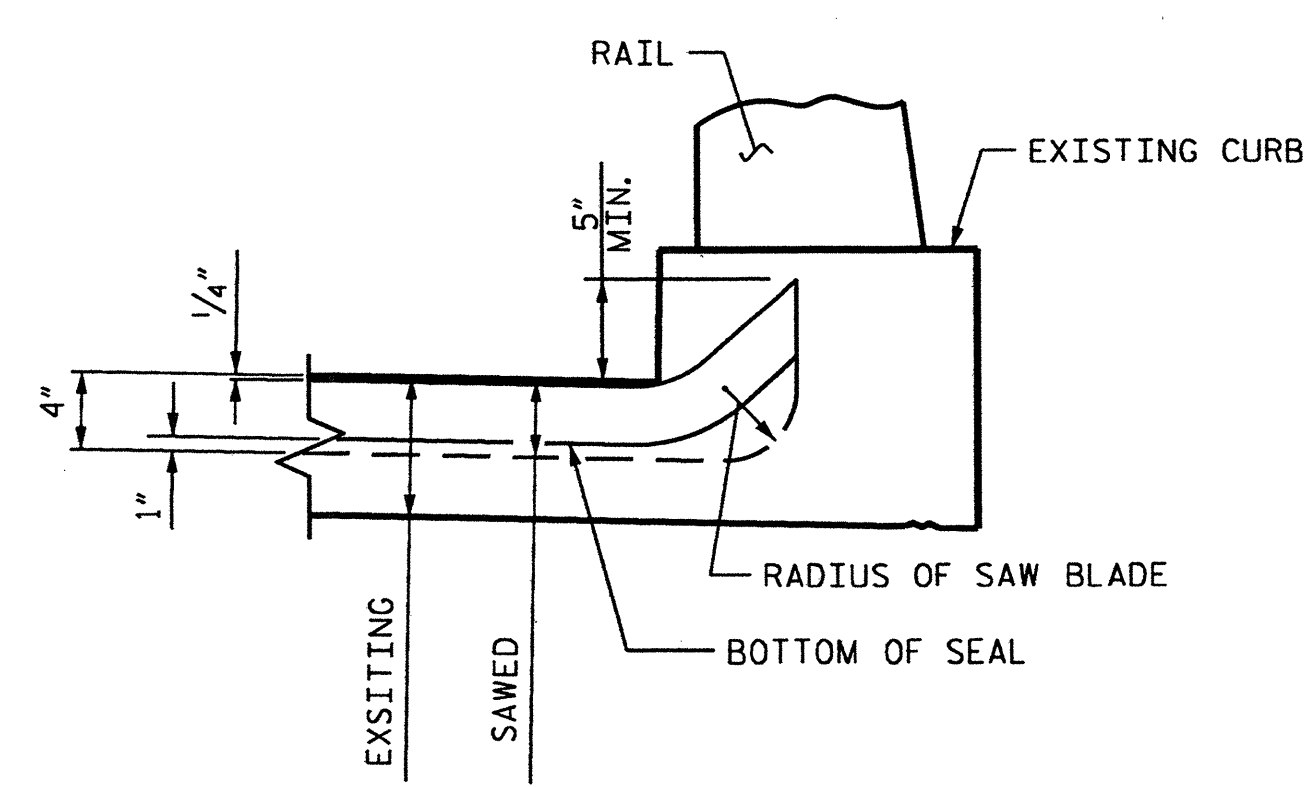

SECTION D-D

ELASTOMERIC CONCRETE	
BENTS	64.9 (CU. FT.)
END BENTS	0 (CU. FT.)
* TOTAL	64.9 (CU. FT.)

* BASED ON THE MINIMUM BLOCKOUT SHOWN.

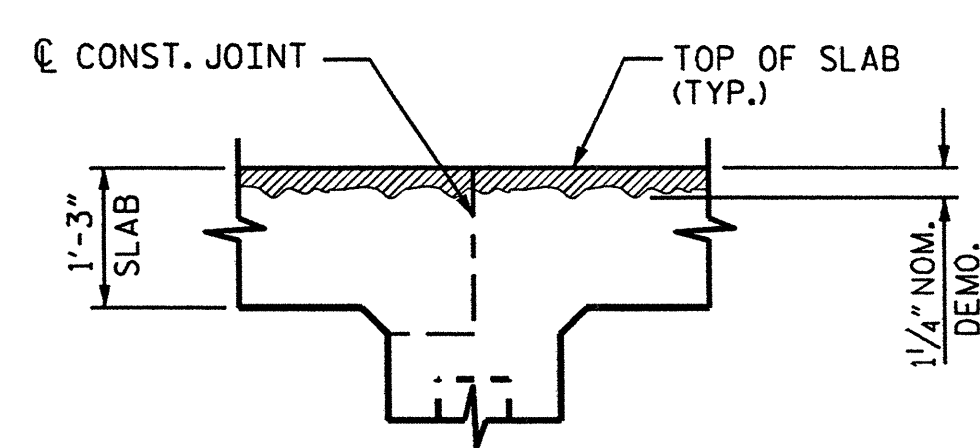

SECTION B-B (EXISTING JOINT)

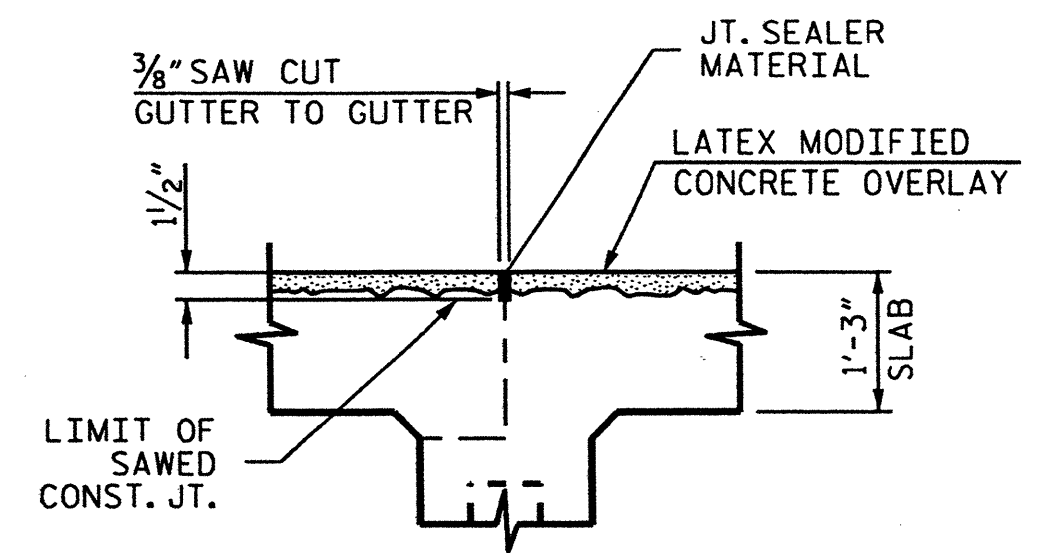

SECTION B-B (PROPOSED JOINT)

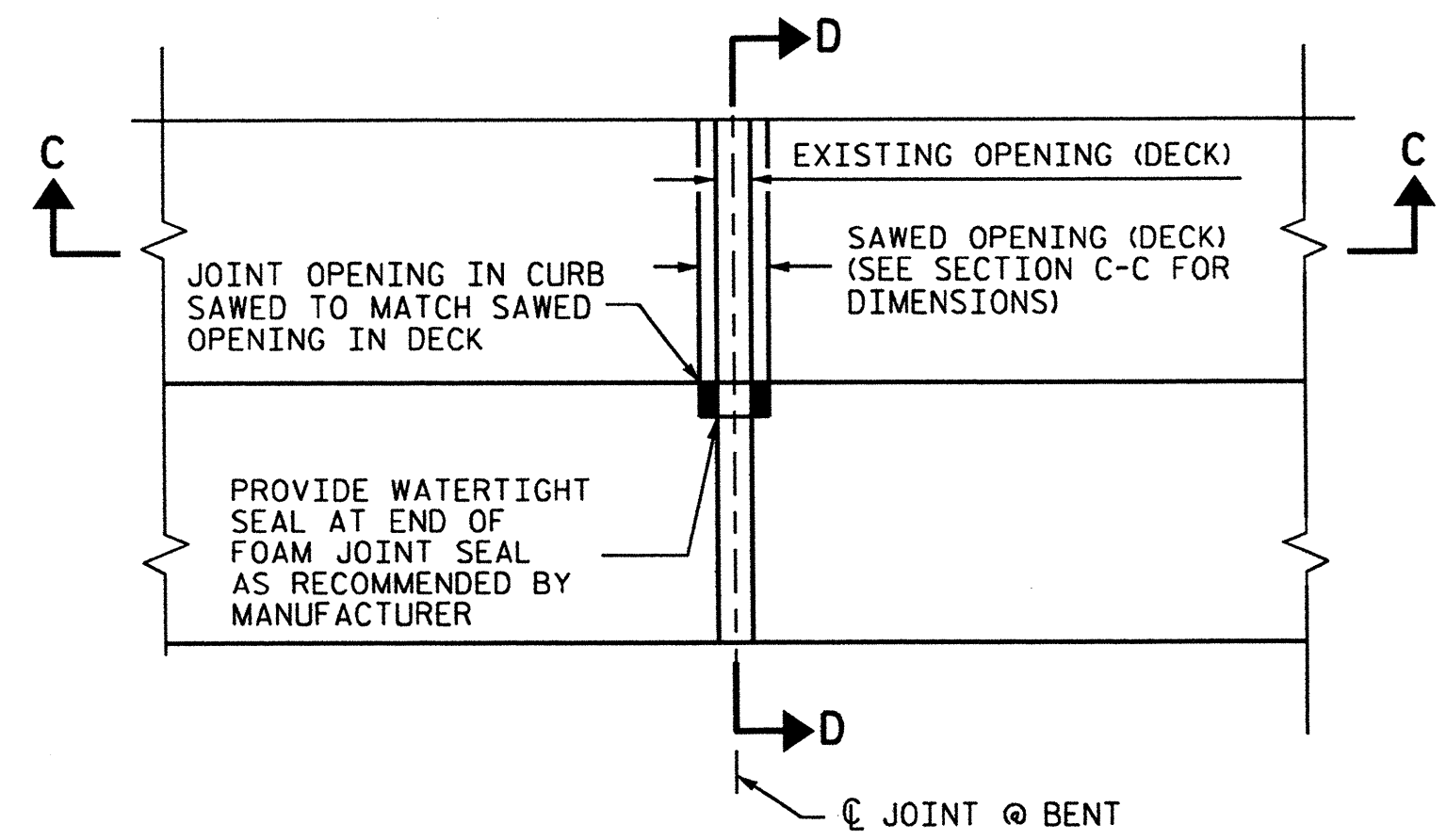

FOAM JOINT SEAL DETAILS

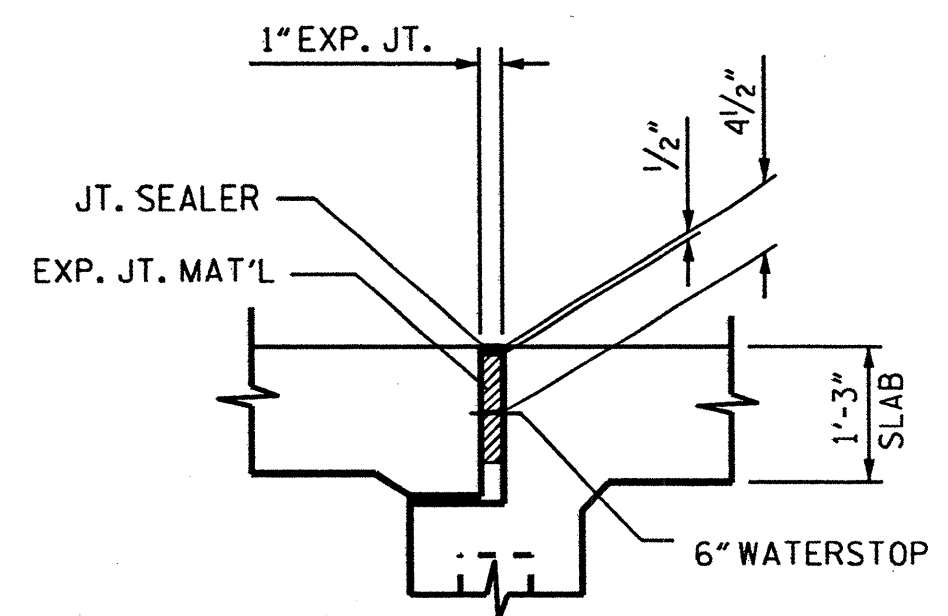

SECTION C-C (EXISTING JOINT)

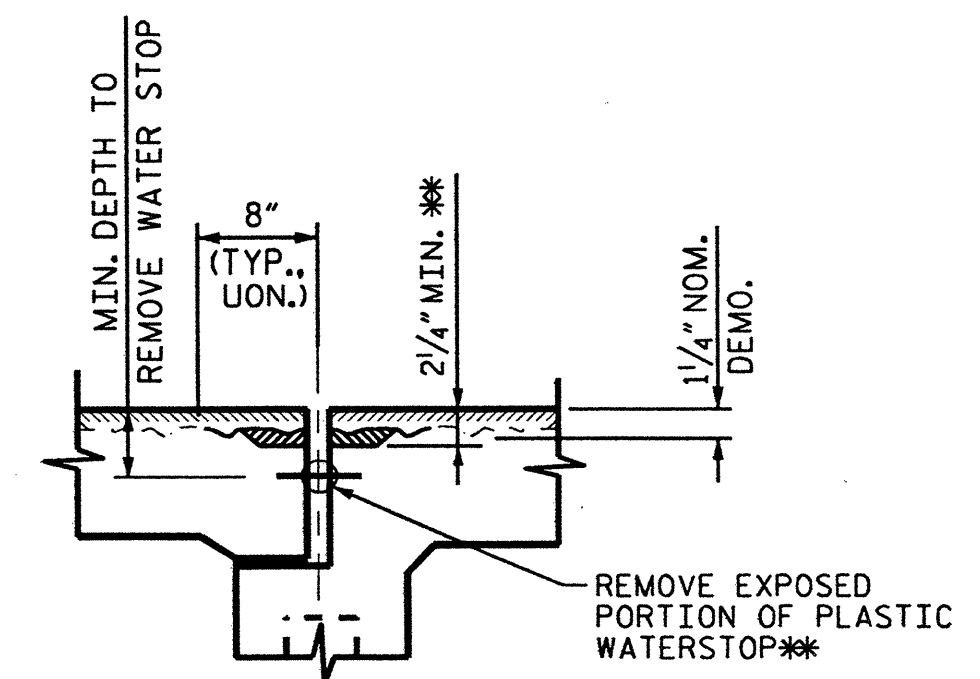

SECTION C-C (MINIMUM EXISTING JOINT DEMOLITION)

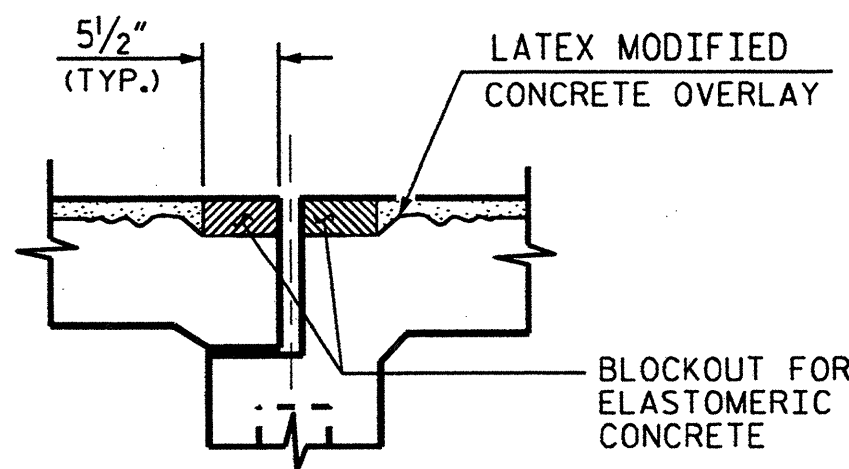

SECTION C-C (PROPOSED FOAM JOINT SEAL PRE-SAWED DIMENSIONS)

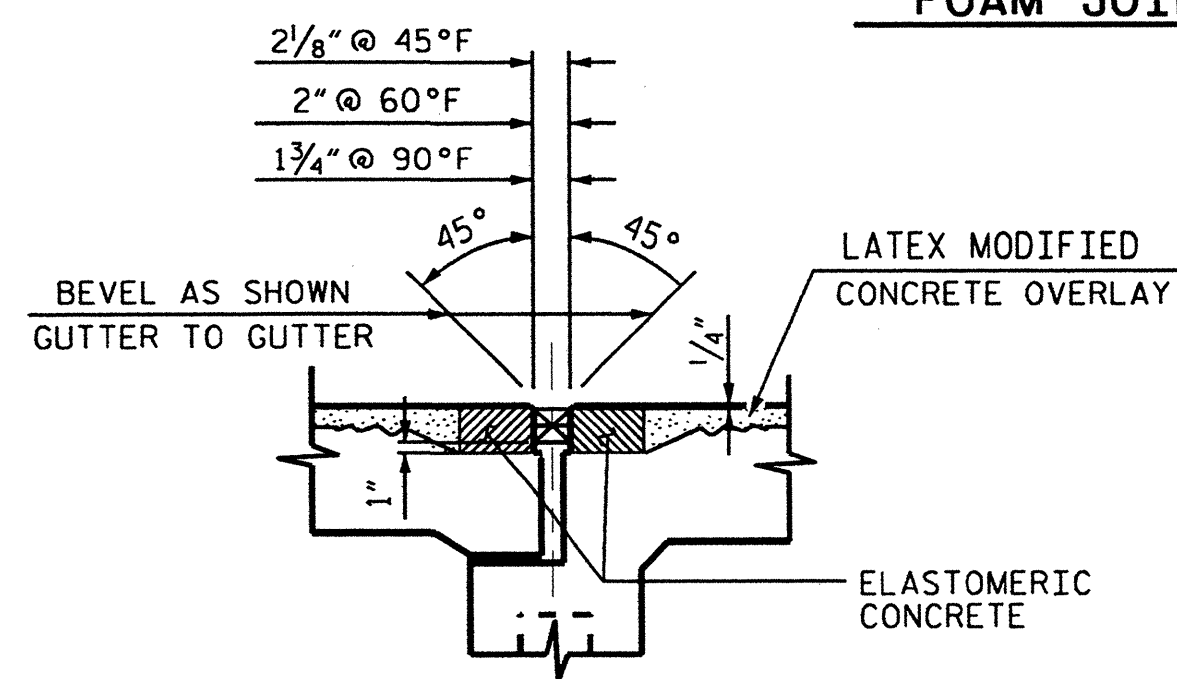

SECTION C-C (PROPOSED FOAM JOINT SEAL EXPANSION)

** ALL LOOSE AND UNSOUND CONCRETE SHALL BE REMOVED. IF THE EMBEDDED PORTION OF THE EXISTING PLASTIC WATERSTOP IS EXPOSED DURING REMOVAL OF UNSOUND CONCRETE, THE ENTIRE WATERSTOP SHALL BE REMOVED.

PROJECT NO. 17BP.1.P.3
 COUNTY: BERTIE
 DECK REPAIR BRIDGE NO. 35
 SHEET 5 OF 8

REVISIONS						SHEET NO.
NO.	BY:	DATE:	NO.	BY:	DATE:	S-11
1			3			TOTAL SHEETS
2			4			50

DRAWN BY : K.H. COMPTON DATE : 9/11
 CHECKED BY : D. SNOKE DATE : 9/11

NOTES

1. FOR EXAMPLES OF TYPICAL ENCAPSULATION OF PILES SEE SHEETS #13 AND #14.
2. REPAIR OF THE BRIDGE SHALL BE PERFORMED SO AS NOT TO ALLOW DEBRIS TO FALL INTO THE WATER.

PILE ENCAPSULATION LOCATIONS

BENT	PILE	LF
16	ALL	51.0
17	ALL	86.4
18	ALL	86.4
19	ALL	64.8
TOTAL	24	289

PILE ENCAPSULATION LENGTHS INCLUDE 1'-0" ABOVE DAMAGED AREA AND 1'-0" BELOW MUD LINE.

QUANTITIES ARE BASED ON BEST AVAILABLE INFORMATION.

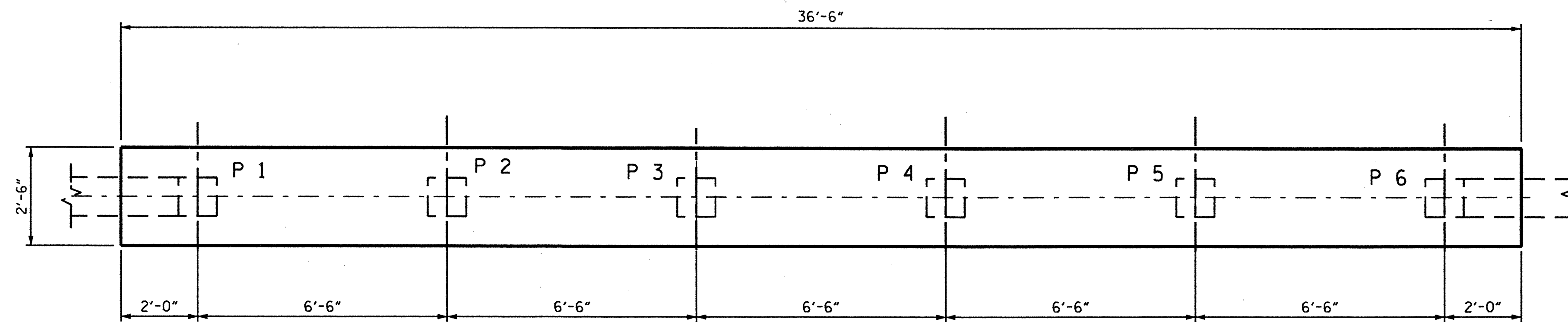

PLAN OF BENT No. 16

(BENT No. 17, 18 & 19 SIMILAR)

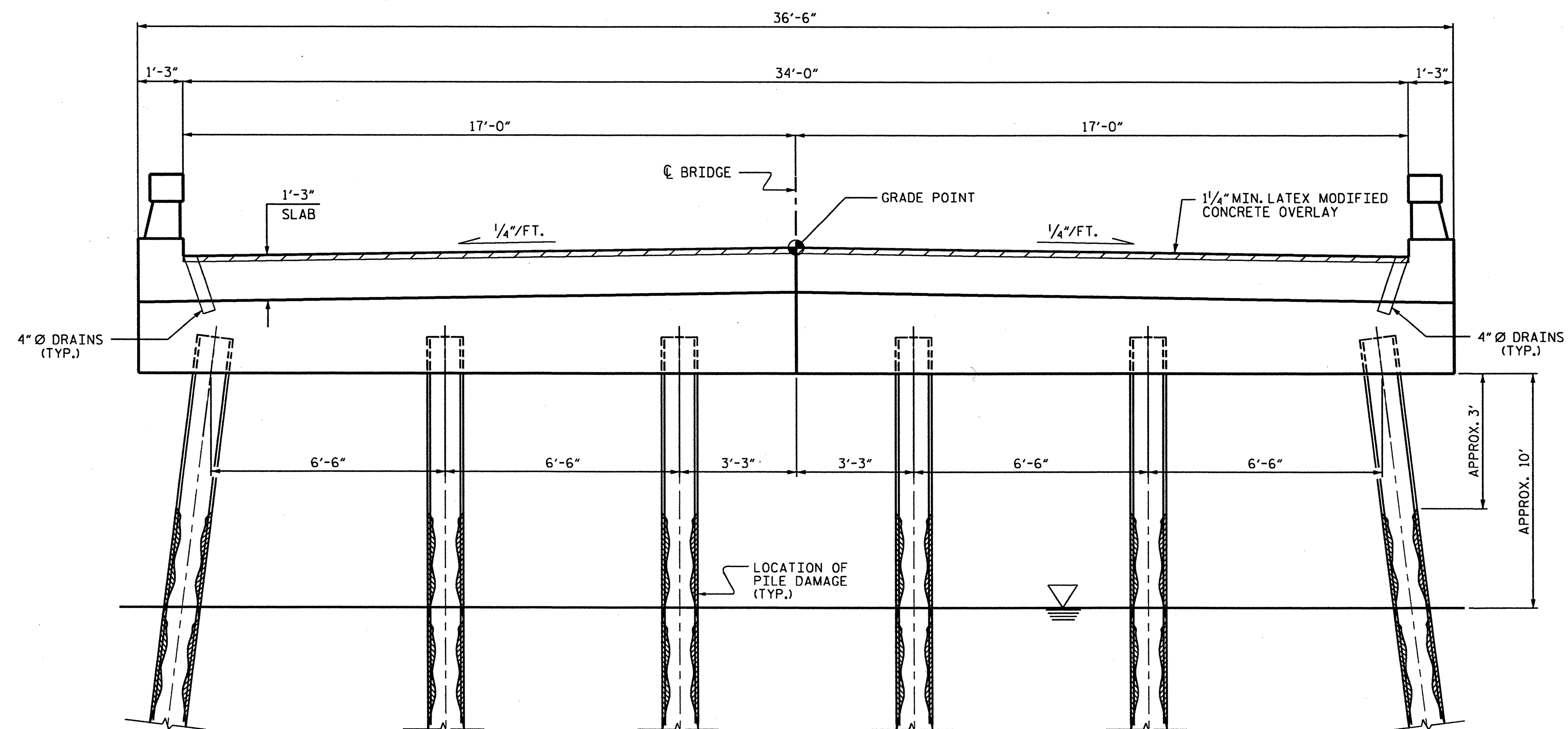

ELEVATION VIEW BENT No. 16

(BENT No. 17, 18, & 19 SIMILAR)

PROJECT NO. 17BP.1.P.3
 COUNTY: BERTIE
 DECK REPAIR BRIDGE NO. 35
 SHEET 6 OF 8

STATE OF NORTH CAROLINA
 DEPARTMENT OF TRANSPORTATION
 RALEIGH

PILE REPAIRS

**BENTS #16, #17,
 #18 AND #19**

REVISIONS						SHEET NO. S-12
NO.	BY:	DATE:	NO.	BY:	DATE:	
1			3			TOTAL SHEETS 50
2			4			

DRAWN BY : K.H. COMPTON DATE : 10/11
 CHECKED BY : D. SNOKE DATE : 10/11

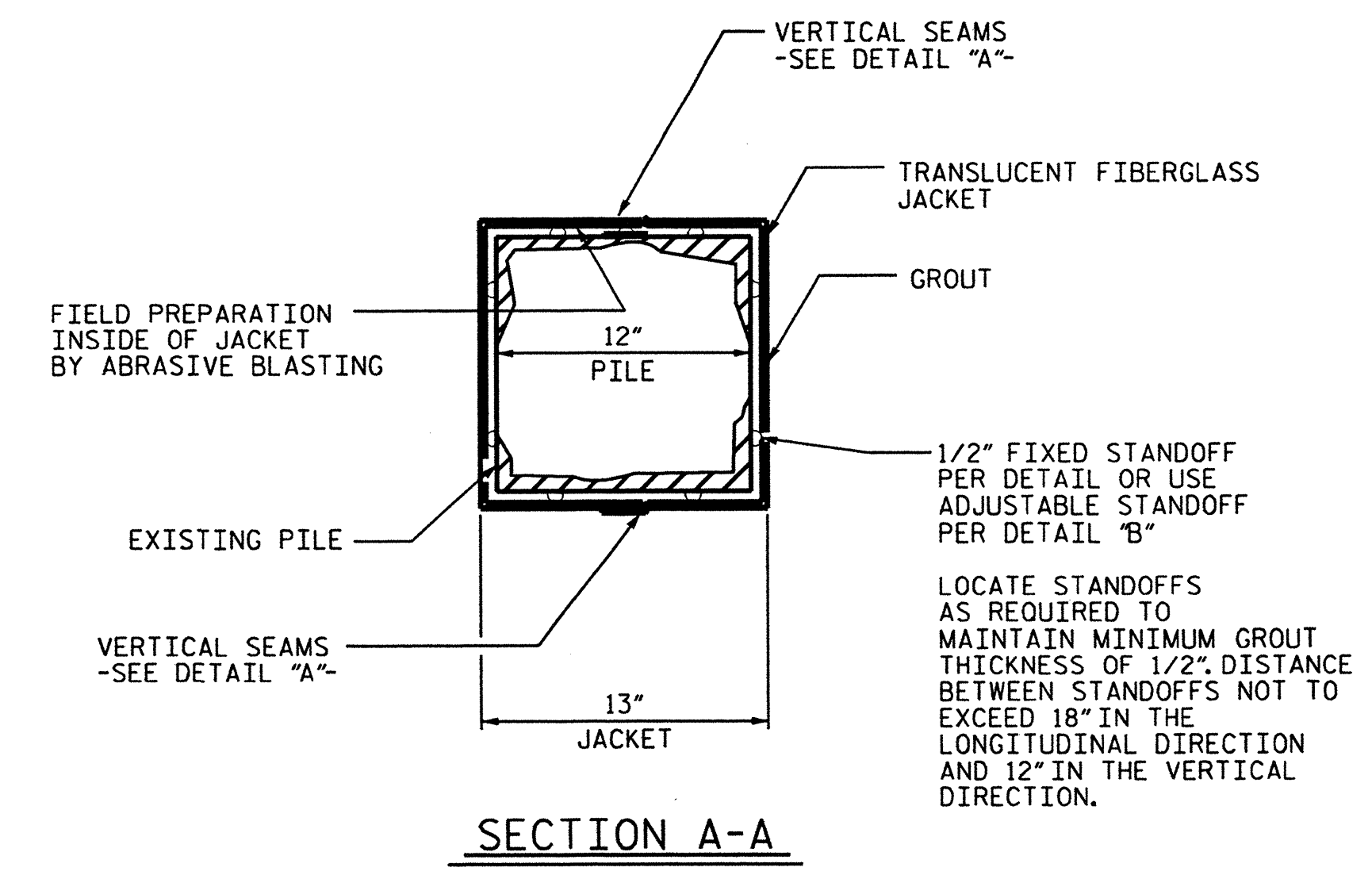
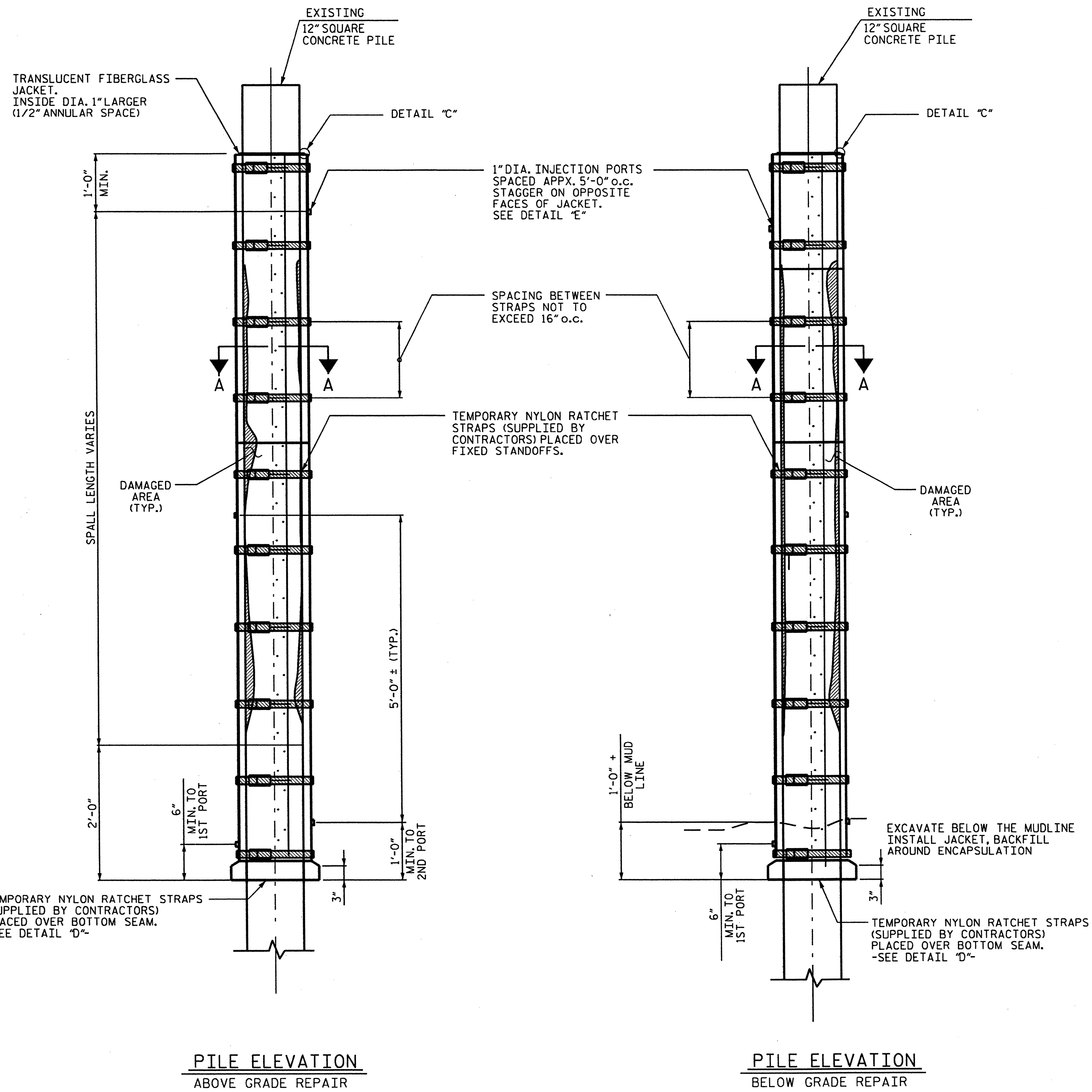

- REPAIR SEQUENCES**
1. AFTER SURFACE PREPARATION, PLACE JACKET IN PROPER LOCATION AROUND PILE AND SEAL LONGITUDINAL SEAMS (SEE DETAIL "A"). INSTALL TEMPORARY BRACING.
 2. CONFIRM SPACING BETWEEN JACKET AND PILE. INSTALL BOTTOM SEAL (SEE DETAIL "D"). ALLOW BOTTOM SEAL TO CURE APPX. 4 HOURS.
 3. ATTACH GROUT HOSE TO LOWERMOST INJECTION PORT AND PUMP A-P-E GROUT FOR 30-sec. CHECK FOR LEAKS ALONG SEAMS AND BOTTOM SEAL. (OPTIONALLY ALLOW THIS GROUT TO CURE AND PROCEED WITH GROUT INJECTION FROM 2nd PORT.)
 4. PLUG UPPER INJECTION PORTS AND PUMP GROUT INTO LOWER PORT UNTIL GROUT REACHES TOP OF JACKET. ONLY USE UPPER PORTS IF INJECTION BECOMES DIFFICULT.

PROJECT NO. 17BP.1.P.3
 COUNTY: BERTIE
 DECK REPAIR BRIDGE NO. 35
 SHEET 7 OF 8

STATE OF NORTH CAROLINA
 DEPARTMENT OF TRANSPORTATION
 RALEIGH

SQUARE PILE
 ENCAPSULATION

DRAWN BY : K.H. COMPTON DATE : 10/11
 CHECKED BY : D. SNOKE DATE : 10/11

REVISIONS						SHEET NO.
NO.	BY:	DATE:	NO.	BY:	DATE:	S-13
1			3			TOTAL SHEETS
2			4			50

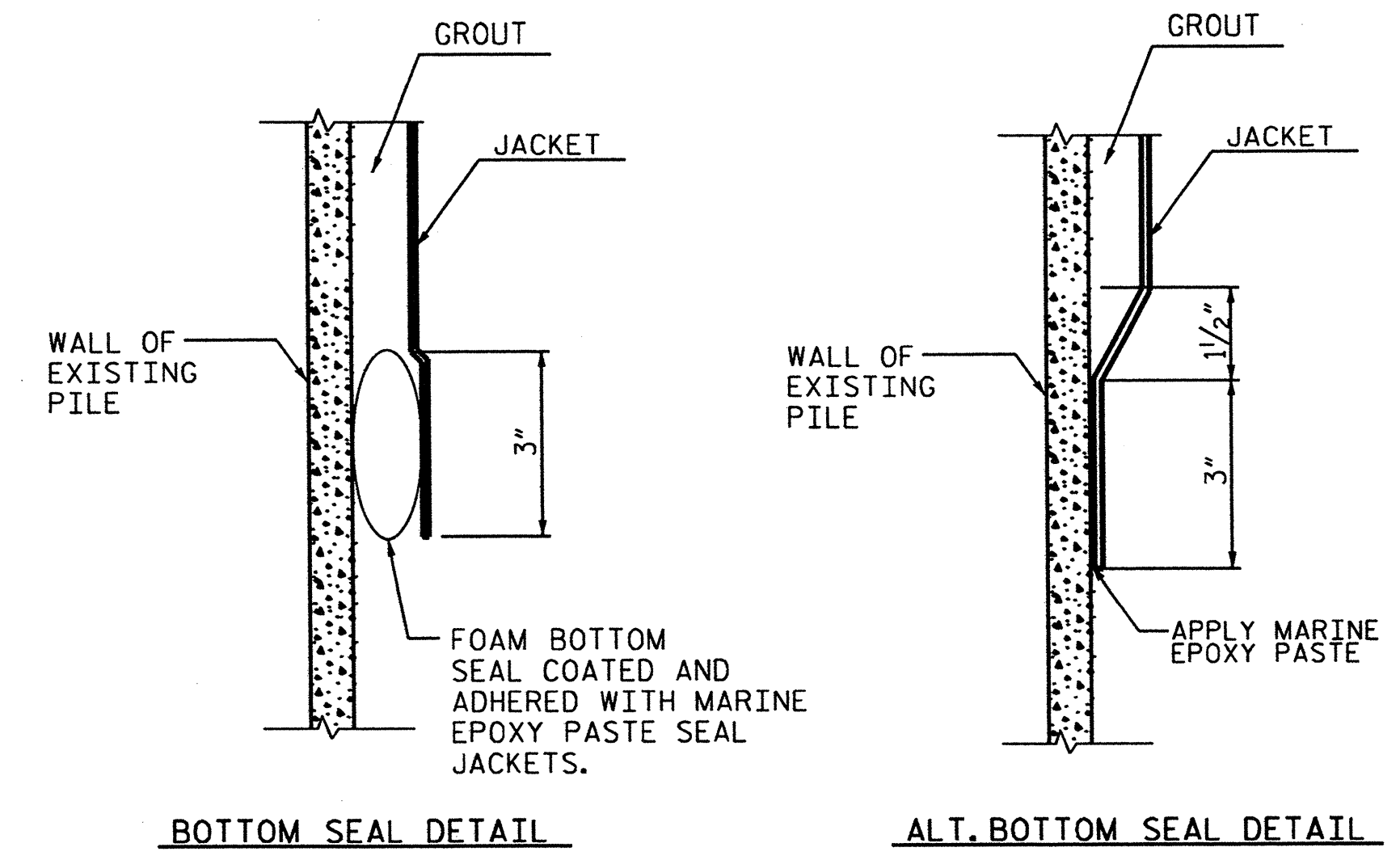
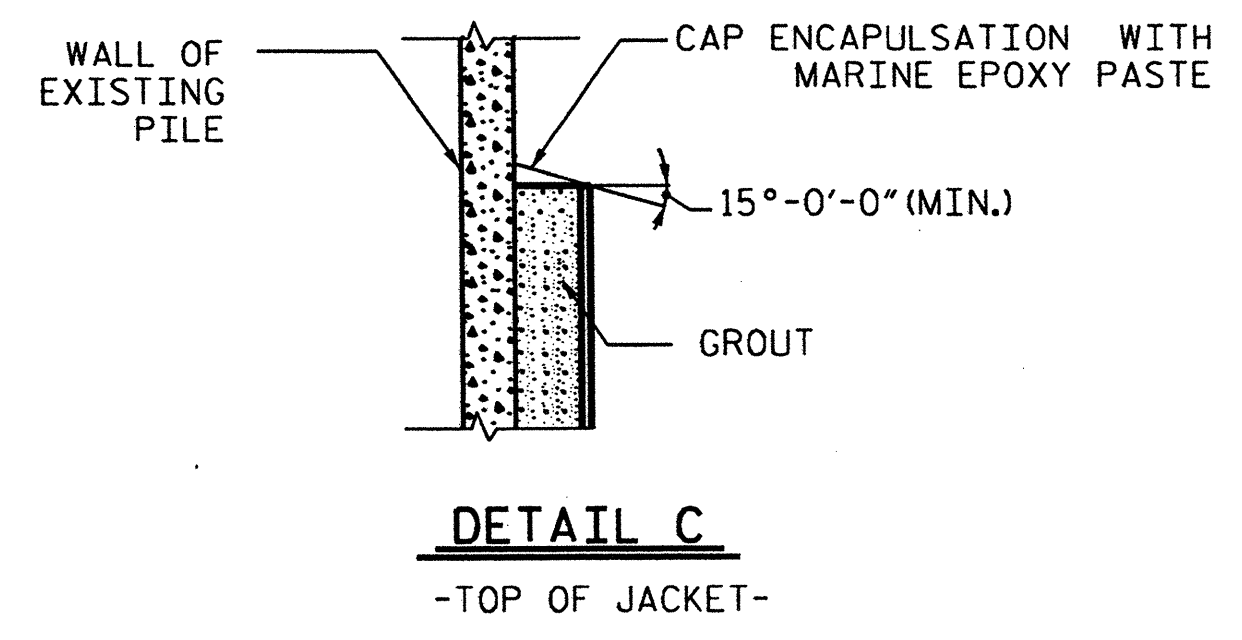
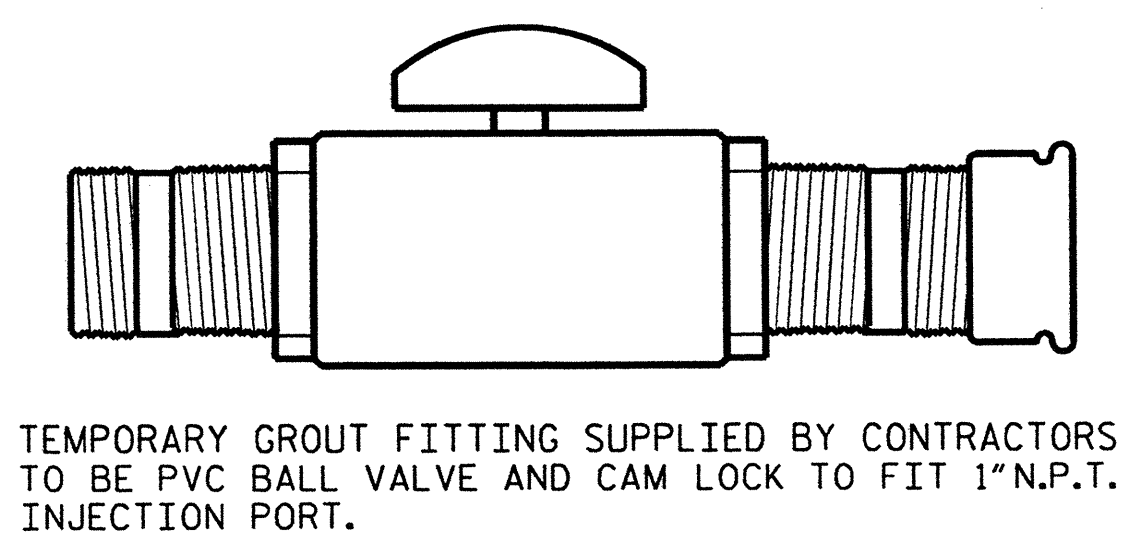
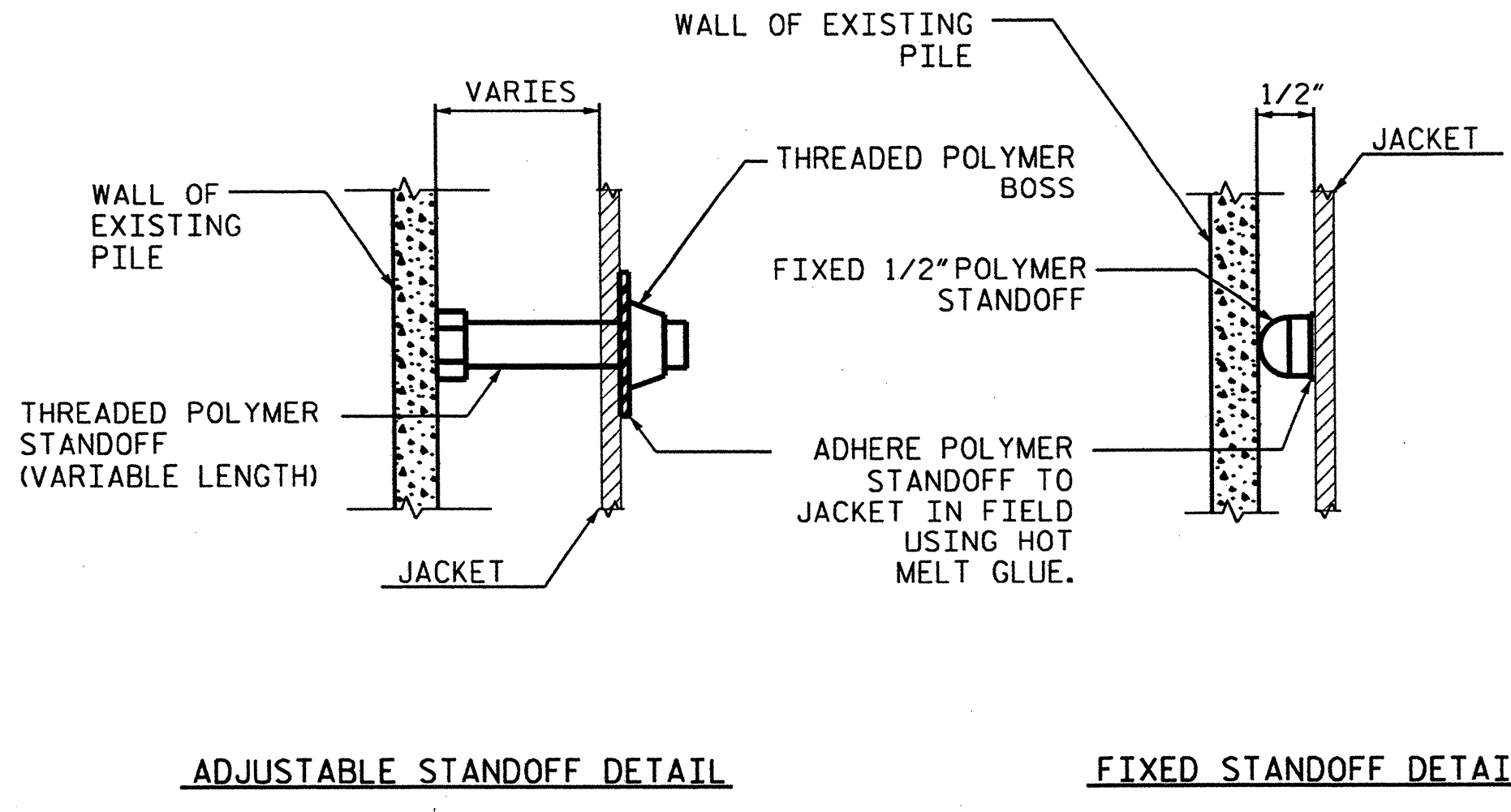
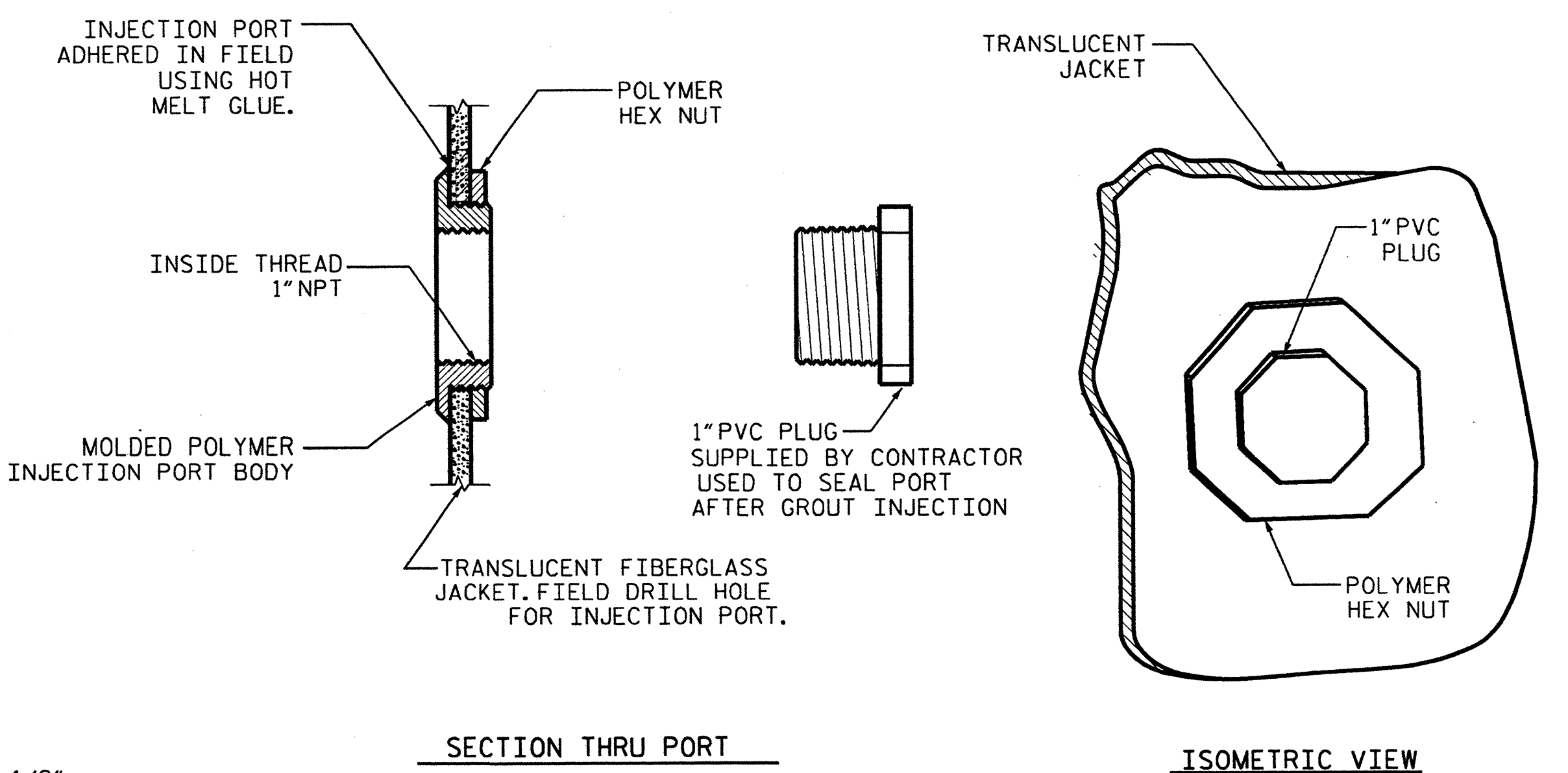
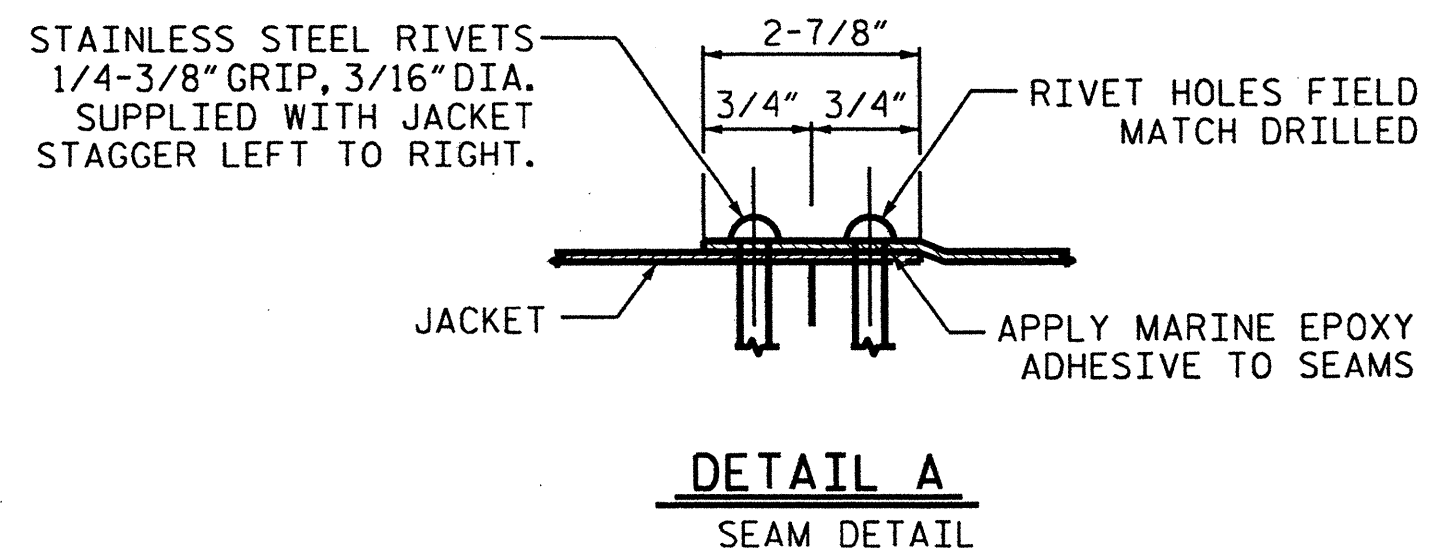
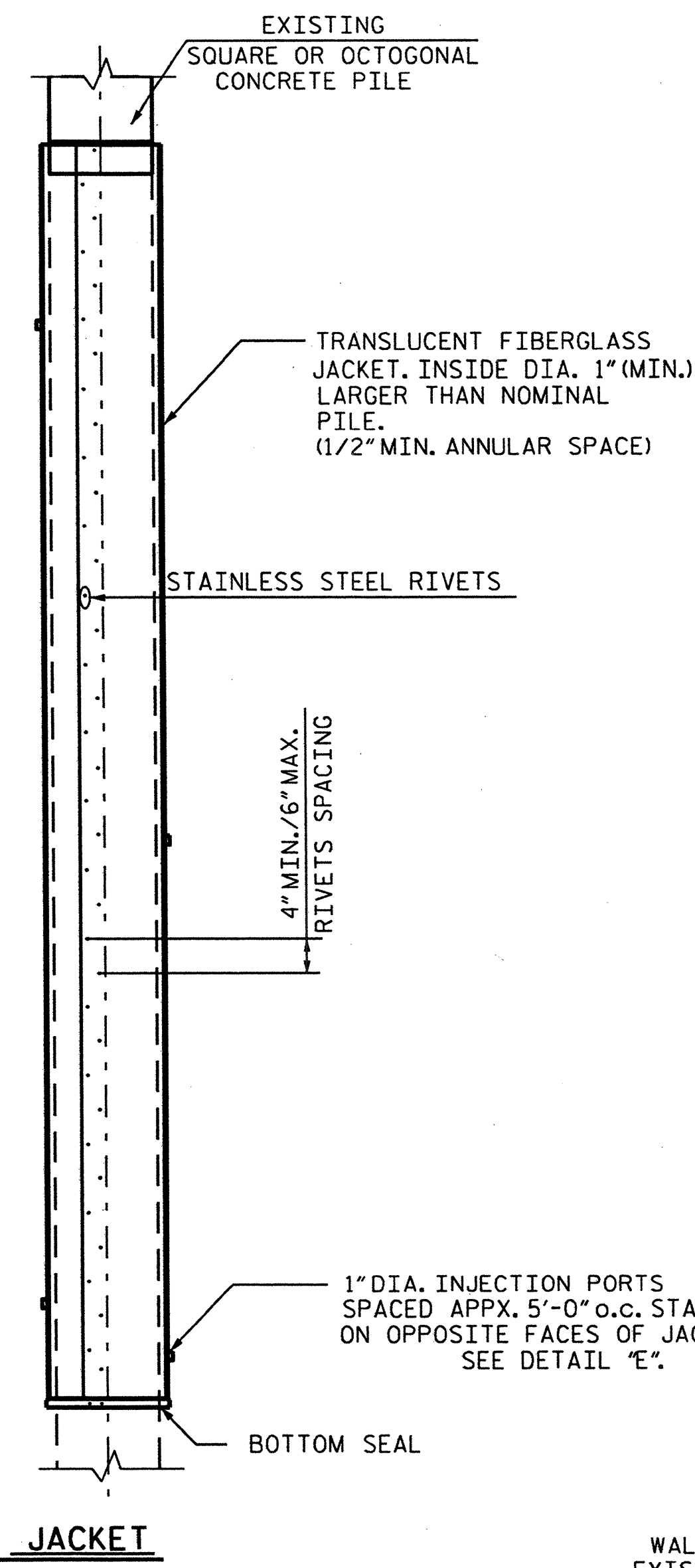

PROJECT NO. 17BP.1.P.3
 COUNTY: BERTIE
 DECK REPAIR BRIDGE NO. 35
 SHEET 8 OF 8

STATE OF NORTH CAROLINA DEPARTMENT OF TRANSPORTATION RALEIGH					SHEET NO. S-14
PILE ENCAPSULATION DETAILS					TOTAL SHEETS 50
REVISIONS					
NO.	BY:	DATE:	NO.	BY:	DATE:
1			3		
2			4		

DRAWN BY : K.H. COMPTON DATE : 10/11
 CHECKED BY : D. SNOKE DATE : 10/11

10-NOV-2011 10:09
 Z:\Squad C\Deck\Division 1\Proj01.dns\DKREHAB_070035.dgn
 dmuller

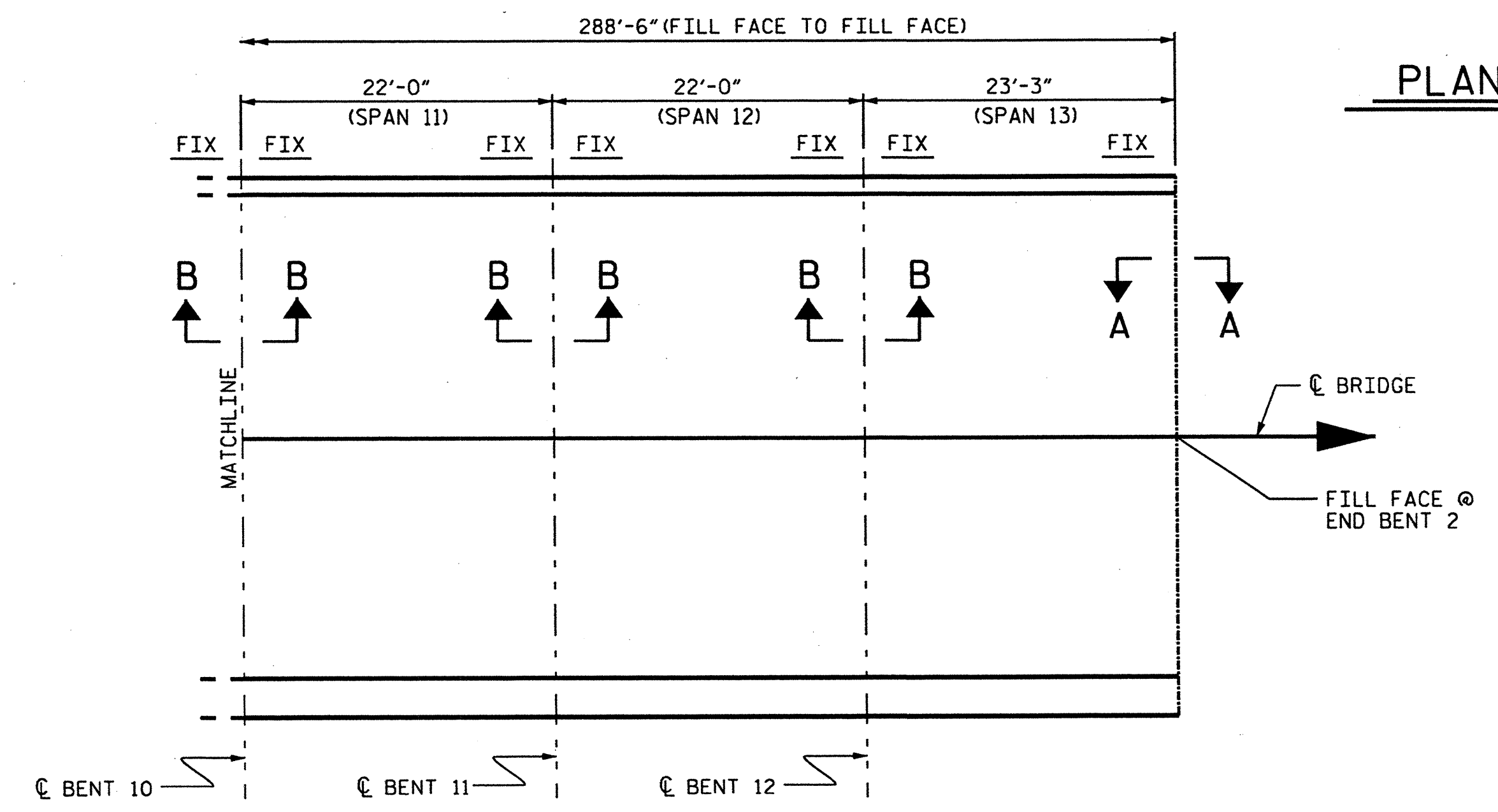
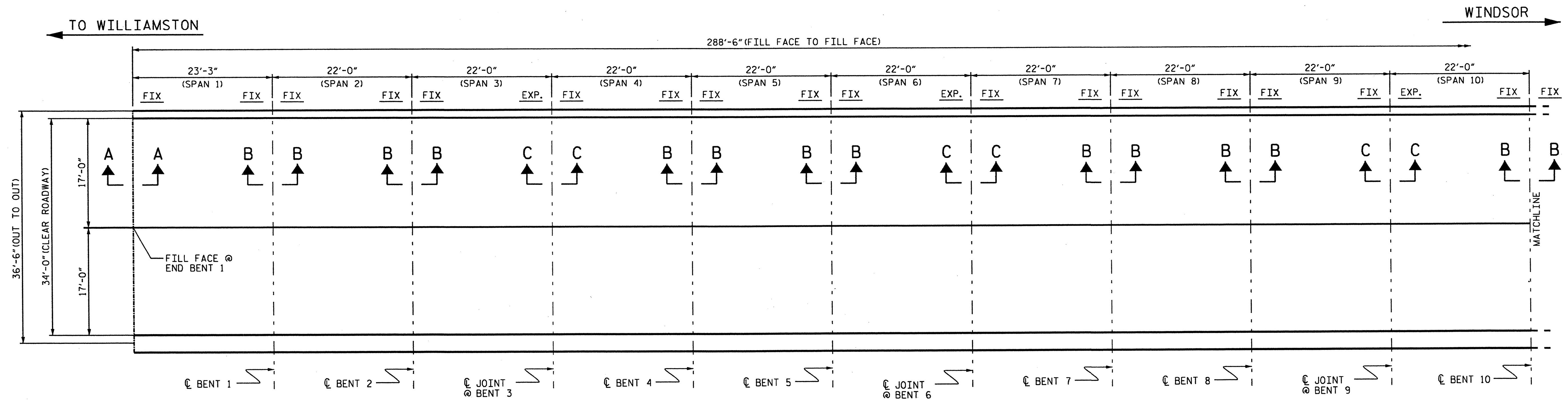

PLAN OF SPANS- DECK REPAIRS

APPROX. AREA: CLASS II REPAIR
 APPROX. AREA: CLASS III REPAIR

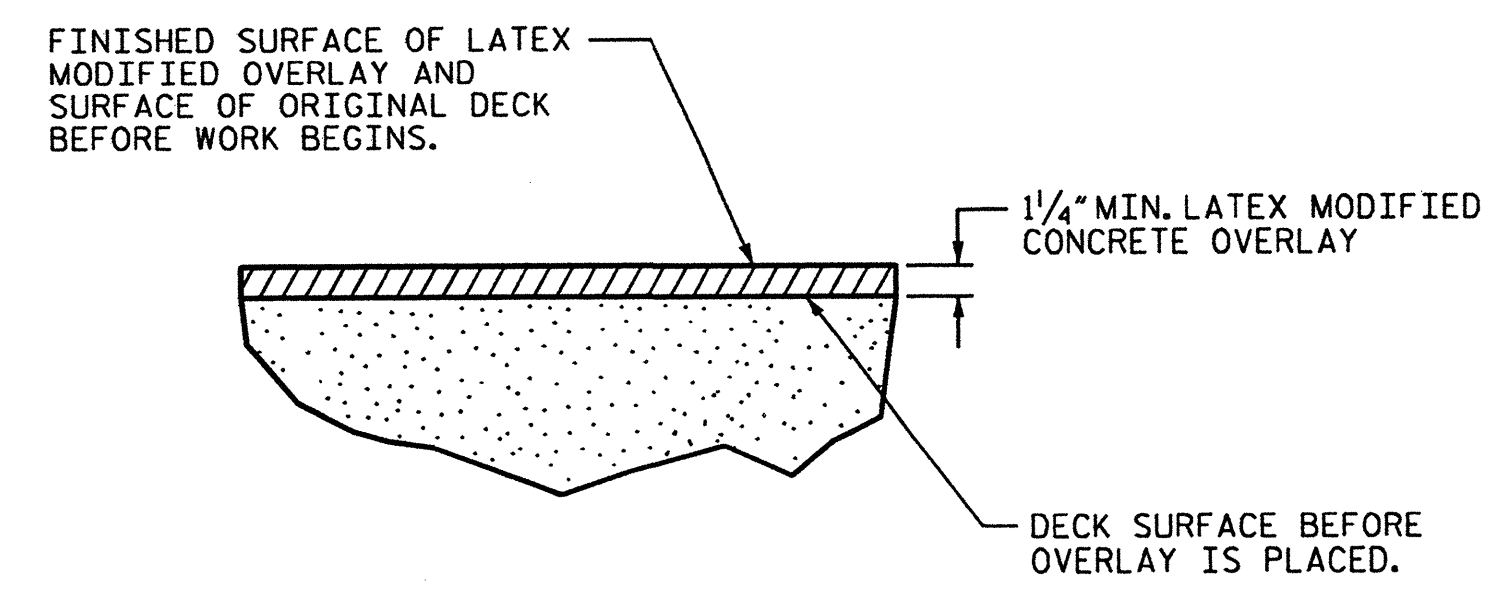

DETAIL FOR LATEX MODIFIED CONCRETE OVERLAY

TOTAL BILL OF MATERIAL									
DECK ** SCARIFICATION	CLASS I SURFACE PREPARATION	CLASS II SURFACE PREPARATION	CLASS III SURFACE PREPARATION	HYDRO-DEMOLITION OF BRIDGE DECK	LATEX MODIFIED CONCRETE	PLACING & FINISHING LATEX MODIFIED CONCRETE	FOAM JOINT SEALS	GROOVING BRIDGE FLOORS	ASPHALT CONC. SURF. COURSE TYPE S9.5B
SO.YDS.	SO.YDS.	SO.YDS.	SO.YDS.	SO.YDS.	C.Y.	SO.YDS.	LUMP SUM	SO. FT.	TON
1,279	0	0	0	1,090	45.4	1,090	LUMP SUM	8,758	17

* QUANTITIES ARE SHOWN FOR INFORMATIONAL PURPOSES ONLY. IF ANY CLASS III LOCATIONS ARE ENCOUNTERED PRIOR TO OR DURING HYDRO-DEMOLITION, SEE TYP. "BLOW THRU" CONTAINMENT AND FALSEWORK DETAILS.
 ** INCLUDES MILLING OF ROADWAY PAVEMENT.

PROJECT NO. 17BP.1.P.3
 COUNTY: BERTIE
 DECK REPAIR BRIDGE NO. 47
 SHEET 1 OF 3

STATE OF NORTH CAROLINA
DEPARTMENT OF TRANSPORTATION
RALEIGH

PLAN OF BRIDGE AND BILL OF MATERIALS

34'-0" CLEAR ROADWAY (90°-00' SKEW)

REVISIONS						SHEET NO. S-15
NO.	BY:	DATE:	NO.	BY:	DATE:	
1			3			TOTAL SHEETS 50
2			4			

DRAWN BY : K.H. COMPTON DATE : 9/11
 CHECKED BY : D. SNOKE DATE : 9/11

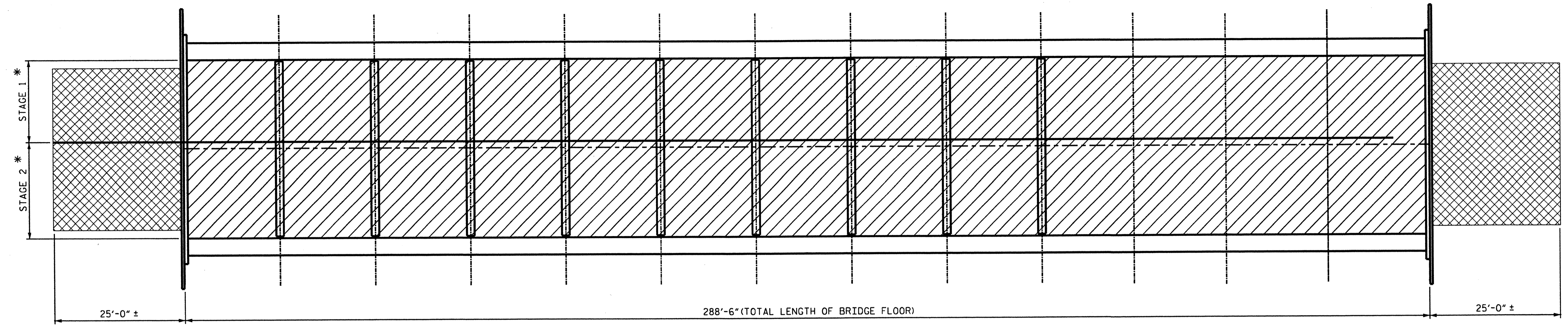

← TO WILLIAMSTON

→ WINDSOR



*SEE STAGING PLAN IN TRAFFIC CONTROL PLAN. SHEET TMP-4

PLAN

-  DECK SCARIFICATION AND HYDRODEMOLITION
-  MILLING OF ROADWAY APPROACH

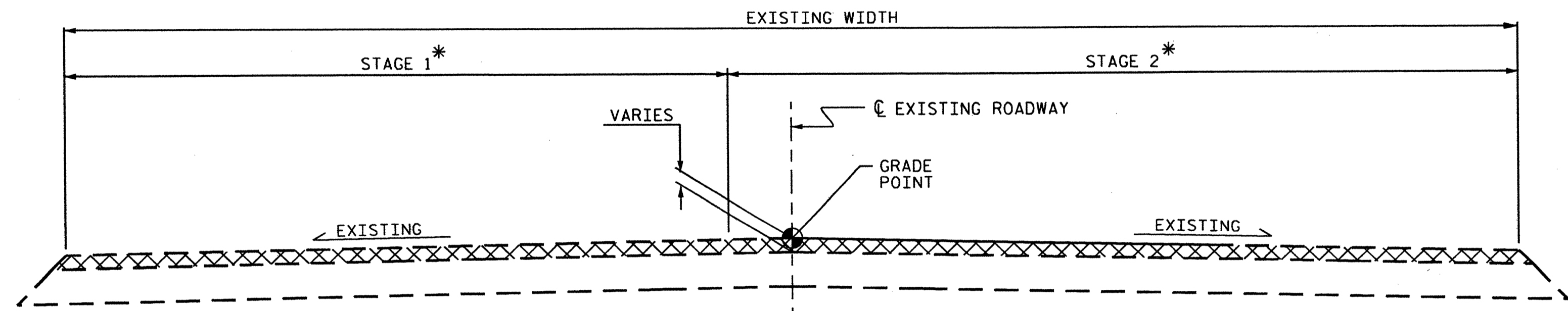

TYPICAL ROADWAY MILLING SECTION

C1 PROPOSED VARIABLE DEPTH ASPHALT CONCRETE SURFACE COURSE, TYPE SF 9.5B AT AN AVERAGE RATE OF 110 LBS. PER SQ. YD. PER 1" DEPTH. TO BE PLACED IN LAYERS NOT LESS THAN 1" IN DEPTH OR GREATER THAN 1 1/2" IN DEPTH.

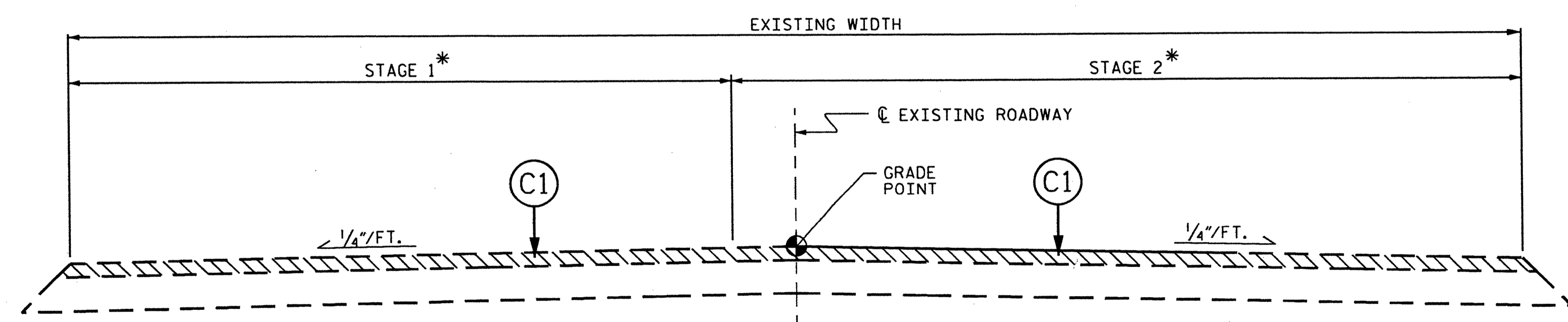

TYPICAL ROADWAY SECTION

PROJECT NO. 17BP.1.P.3
 COUNTY: BERTIE
 DECK REPAIR BRIDGE NO. 47
 SHEET 2 OF 3

STATE OF NORTH CAROLINA
 DEPARTMENT OF TRANSPORTATION
 RALEIGH

TYPICAL ROADWAY SECTION AND MILLING DETAILS

REVISIONS						SHEET NO.
NO.	BY:	DATE:	NO.	BY:	DATE:	S-16
1			3			TOTAL SHEETS
2			4			50

DRAWN BY : K.H. COMPTON DATE : 9/11
 CHECKED BY : D. SNOKE DATE : 9/11

NOT TO SCALE

10-NOV-2011 10:09
 Z:\Squad C\Deck\Division 1\Proj01.dns\DKREHAB_070047.dgn
 dmuller

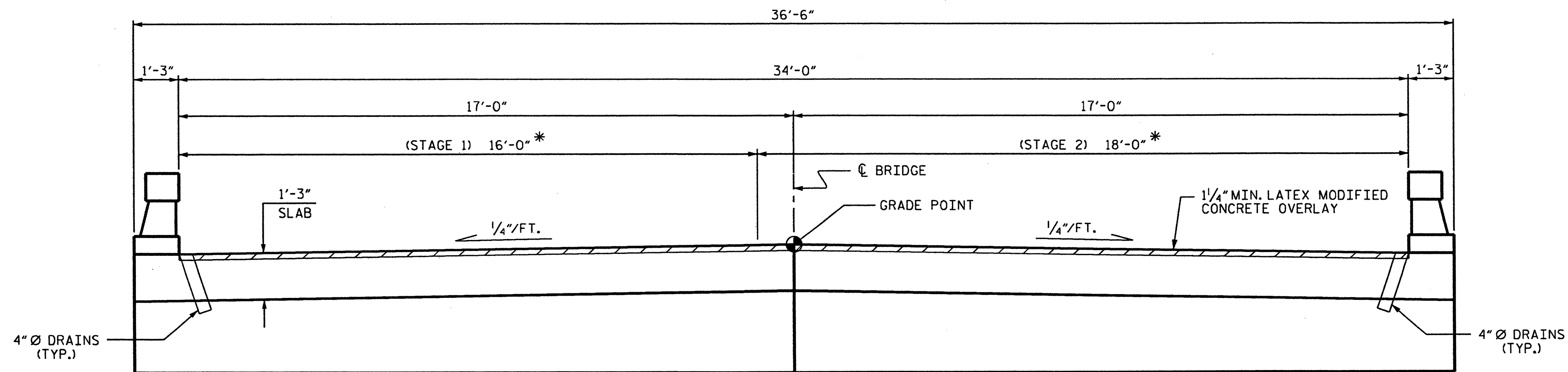

TYPICAL SECTION

*SEE STAGING PLAN IN TRAFFIC CONTROL PLAN, SHEET TMP-4

NOTES

EXISTING DECK DRAINS SHALL BE SEALED PRIOR TO BEGINNING REPAIR OF BRIDGE DECKS WITH LATEX MODIFIED CONCRETE. SEE SPECIAL PROVISIONS.

FOR HYDRO-DEMOLITION, SEE SPECIAL PROVISIONS.

THE CONTRACTOR MUST COLLECT, TREAT AND DISPOSE OF RUN-OFF WATER FROM THE HYDRO-DEMOLITION PROCESS, SEE SPECIAL PROVISIONS.

THE BOUNDARIES OF AREAS IDENTIFIED FOR CLASS III SURFACE PREPARATION ARE APPROXIMATE. THE CONTRACTOR SHALL PROVIDE A METHOD OF HANDLING UNEXPECTED BLOW THROUGH OF DECK. SEE DETAIL.

FOR OVERLAY OF BRIDGE DECKS WITH LATEX MODIFIED CONCRETE, SEE SPECIAL PROVISIONS.

SEE SPECIAL PROVISIONS FOR SURFACE PREPARATION.

EXISTING BRIDGE INFORMATION BASED ON BEST AVAILABLE DATA.

FOR FOAM JOINT SEAL SEE SPECIAL PROVISIONS.

THE INSTALLED FOAM JOINT SEAL SHALL BE WATER TIGHT.

NOMINAL UNCOMPRESSED SEAL WIDTH OF FOAM JOINT SEAL SHALL BE 2 1/2" AT BENTS.

THE CONTRACTOR WILL NOT BE PERMITTED TO FORM THE JOINT FOR THE FOAM JOINT SEAL IN LIEU OF SAWING THE JOINT

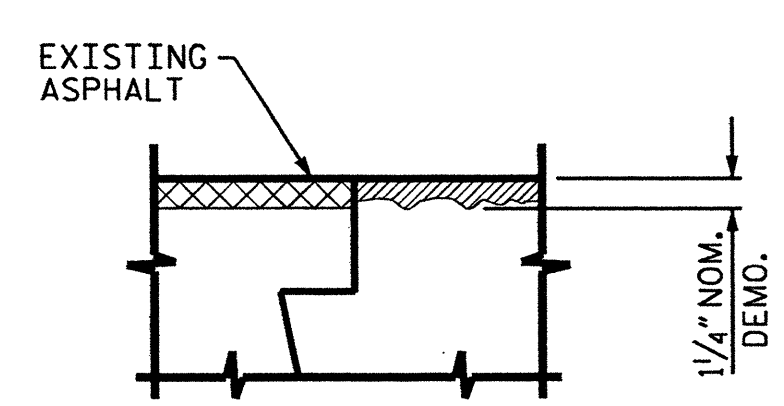

**SECTION A-A
(EXISTING JOINT)**

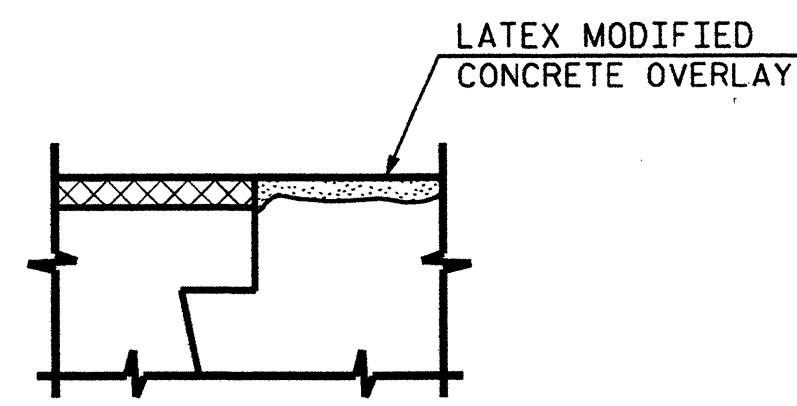

**SECTION A-A
(PROPOSED JOINT)**

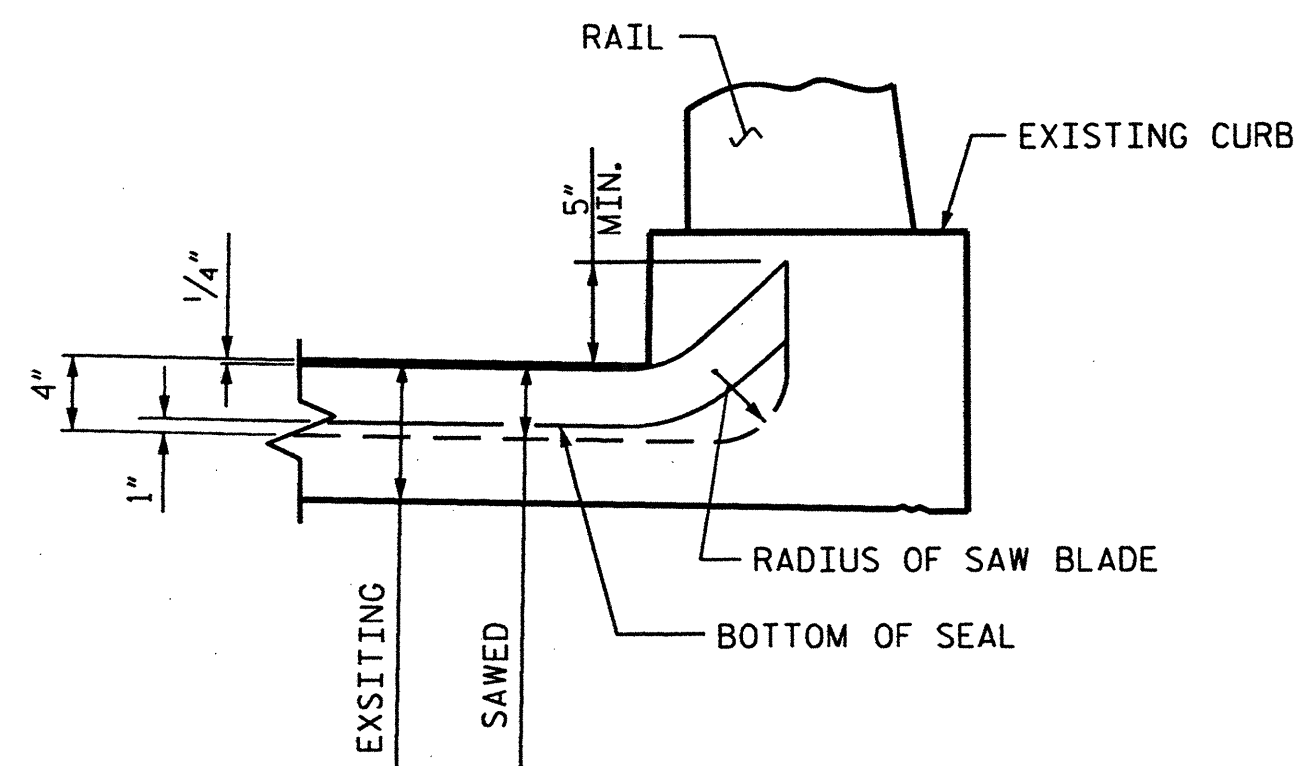

SECTION D-D

ELASTOMERIC CONCRETE	
BENTS	19.5 (CU. FT.)
END BENTS	0 (CU. FT.)
* TOTAL	19.5 (CU. FT.)

* BASED ON THE MINIMUM BLOCKOUT SHOWN.

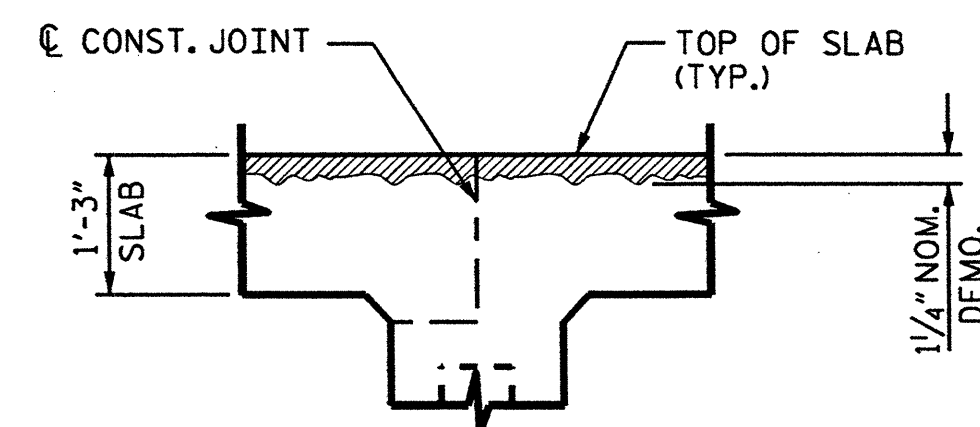

**SECTION B-B
(EXISTING JOINT)**

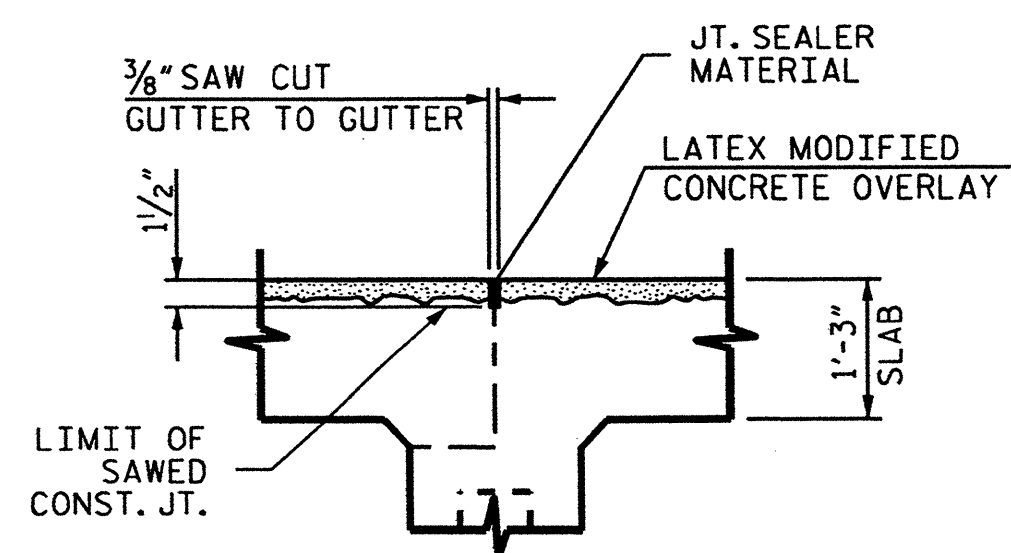

**SECTION B-B
(PROPOSED JOINT)**

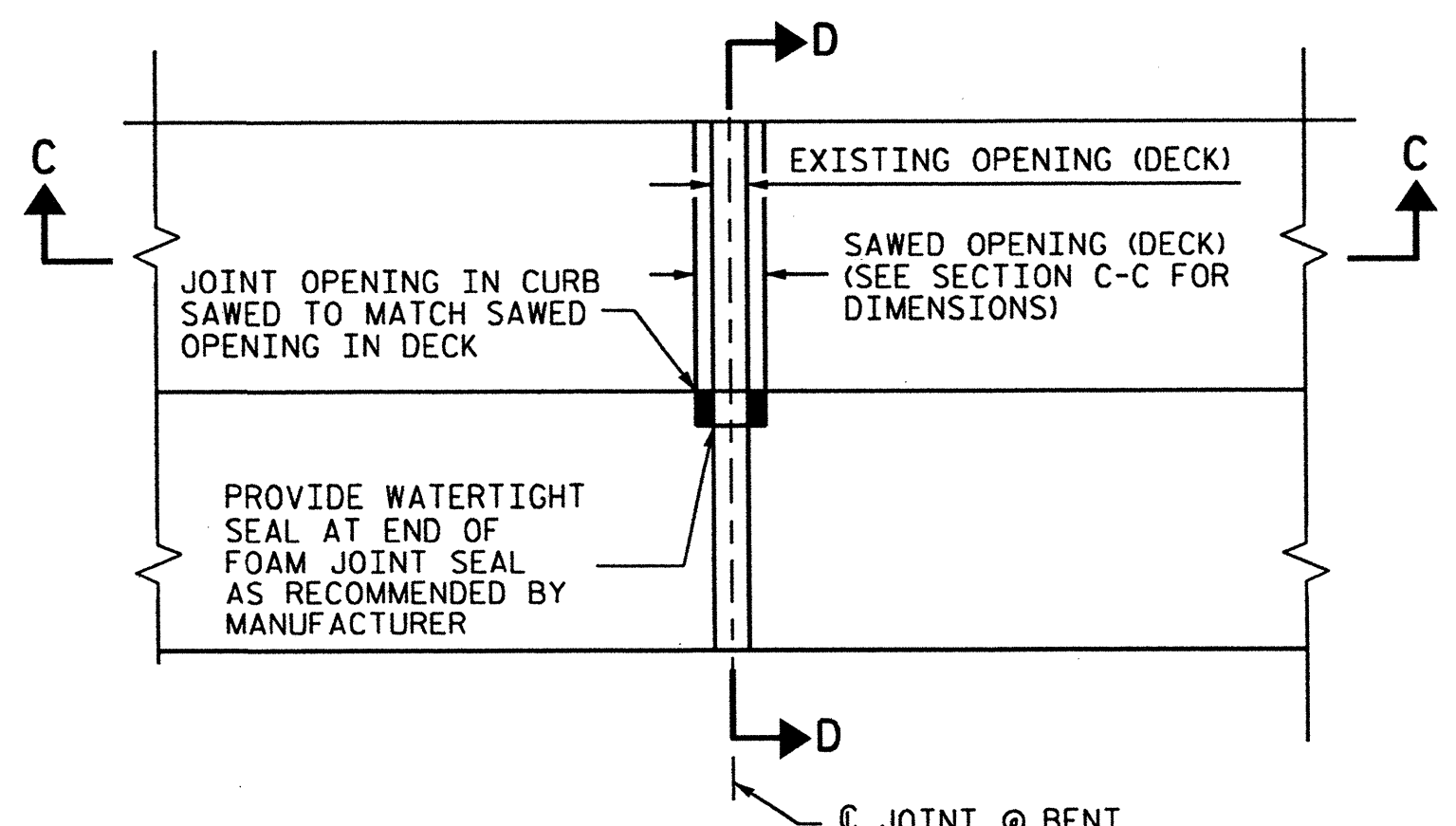

FOAM JOINT SEAL DETAILS

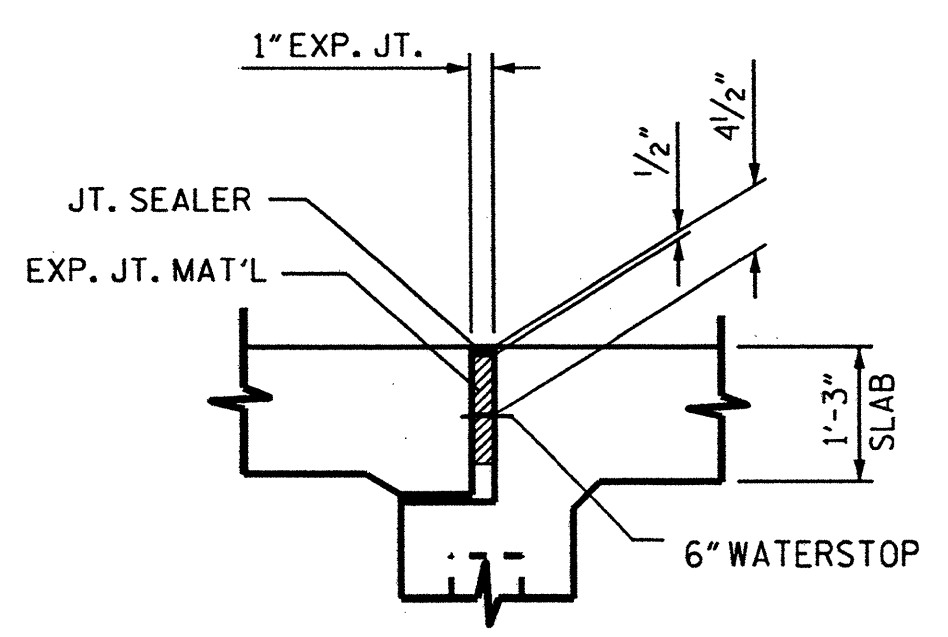

**SECTION C-C
(EXISTING JOINT)**

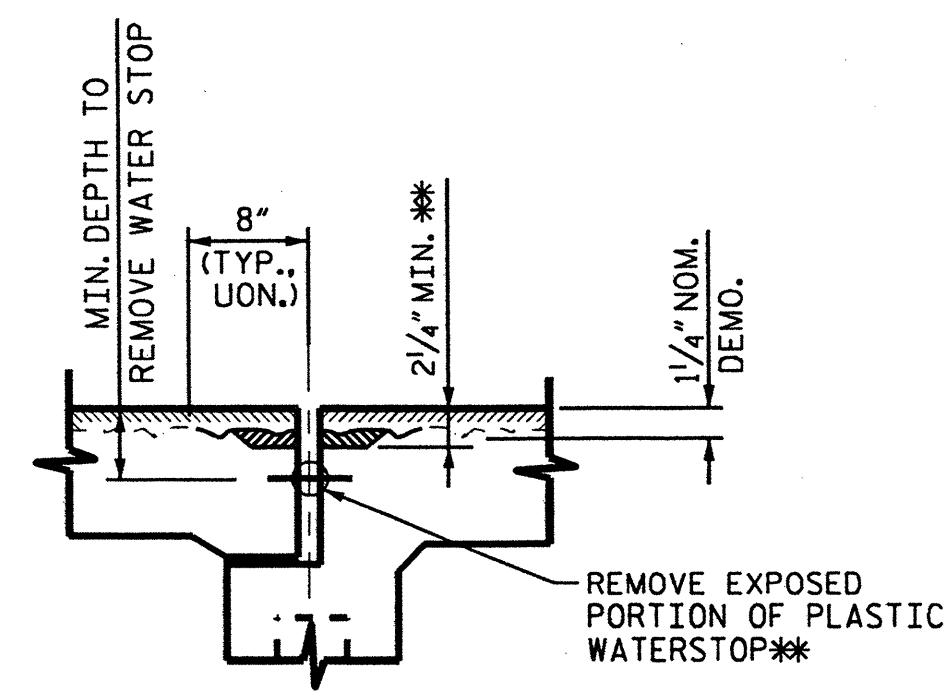

**SECTION C-C
(MINIMUM EXISTING JOINT SEAL PRE-DEMOLITION)**

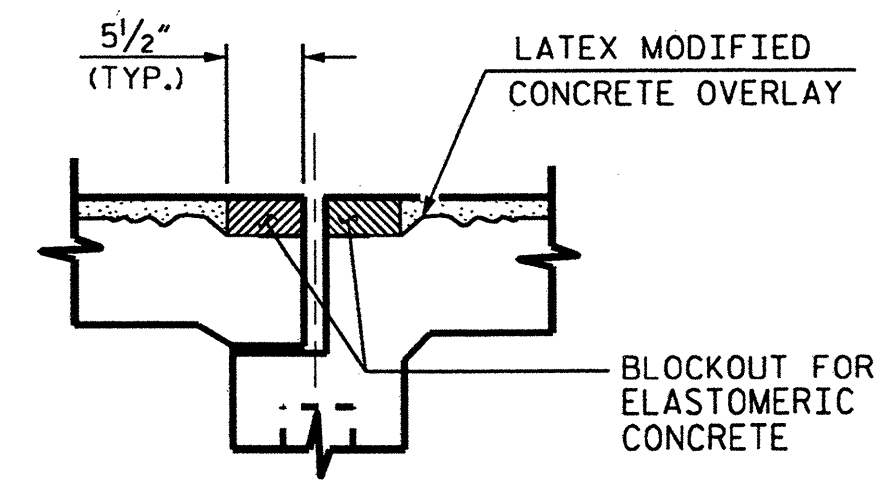

**SECTION C-C
(PROPOSED FOAM JOINT SEAL PRE-SAWED DIMENSIONS)**

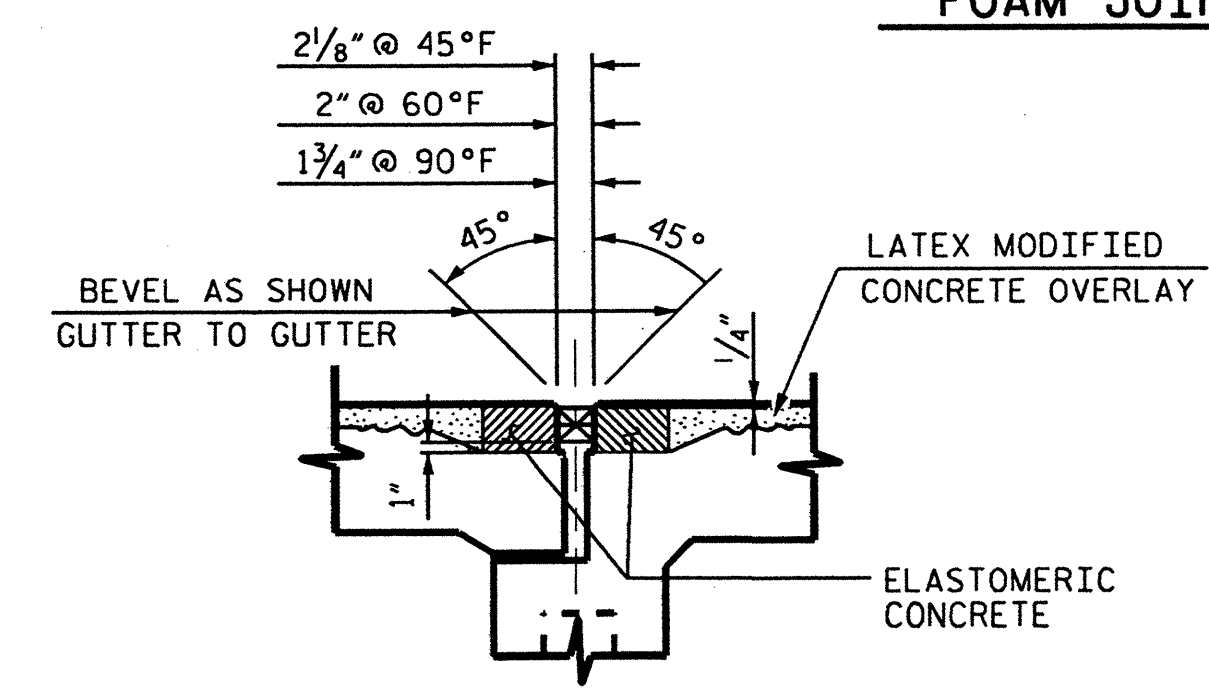

**SECTION C-C
(PROPOSED FOAM JOINT SEAL EXPANSION)**

** ALL LOOSE AND UNSOUND CONCRETE SHALL BE REMOVED. IF THE EMBEDDED PORTION OF THE EXISTING PLASTIC WATERSTOP IS EXPOSED DURING REMOVAL OF UNSOUND CONCRETE, THE ENTIRE WATERSTOP SHALL BE REMOVED.

PROJECT NO. 17BP.1.P.3
 COUNTY: BERTIE
 DECK REPAIR BRIDGE NO. 47
 SHEET 3 OF 3

STATE OF NORTH CAROLINA
 DEPARTMENT OF TRANSPORTATION
 RALEIGH

**TYPICAL SECTION
 AND
 JOINT DETAILS**

REVISIONS						SHEET NO.	
NO.	BY:	DATE:	NO.	BY:	DATE:	S-17	
1			3			TOTAL SHEETS	
2			4			50	

DRAWN BY : K.H. COMPTON DATE : 9/11
 CHECKED BY : D. SNOKE DATE : 9/11

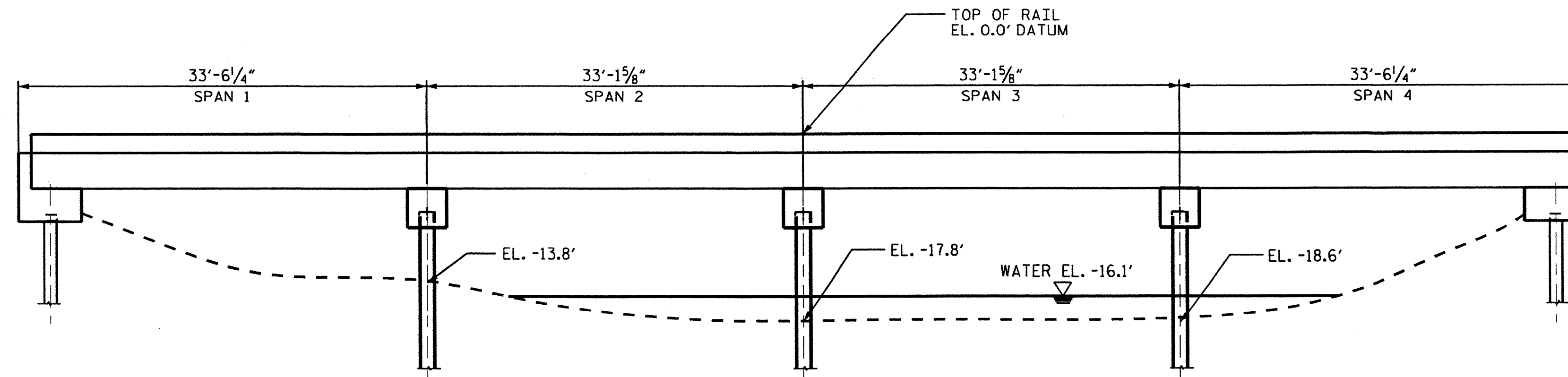

PROFILE OF BRIDGE

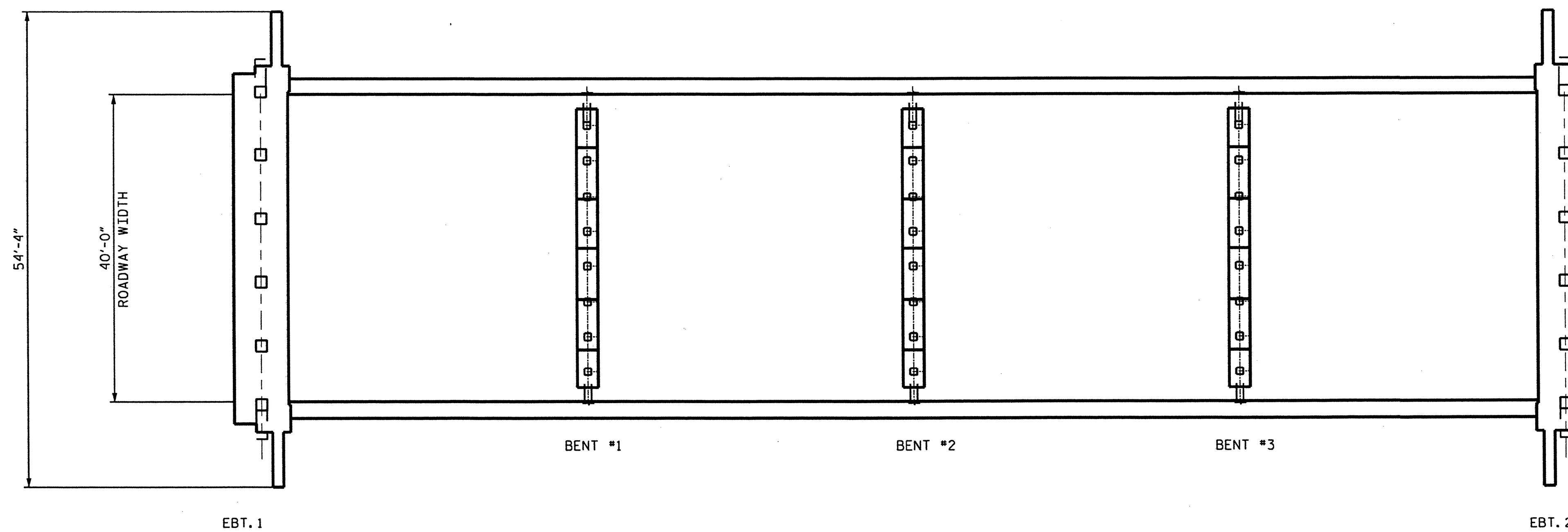

PLAN OF BRIDGE

PROJECT NO. 17BP.1.P.3
 COUNTY: BERTIE
 DECK REPAIR BRIDGE NO. 49
 SHEET 1 OF 7

TOTAL BILL OF MATERIAL										
DECK** SCARIFICATION	CLASS I* SURFACE PREPARATION	CLASS II* SURFACE PREPARATION	CLASS III* SURFACE PREPARATION	HYDRO- DEMOLITION OF BRIDGE DECK	LATEX MODIFIED CONCRETE	PLACING & FINISHING LATEX MODIFIED CONCRETE	FOAM JOINT SEALS	GROOVING BRIDGE FLOORS	ASPHALT CONC. SURF. COURSE TYPE S9.5B	PILE ENCAPSULATION
SO.YDS.	SO.YDS.	SO.YDS.	SO.YDS.	SO.YDS.	C.Y.	SO.YDS.	LUMP SUM	SO. FT.	TON	LF
593	0	0	0	593	24.7	593	LUMP SUM	4,711	0	139

* QUANTITIES ARE SHOWN FOR INFORMATIONAL PURPOSES ONLY. IF ANY CLASS III LOCATIONS ARE ENCOUNTERED PRIOR TO OR DURING HYDRO-DEMOLITION, SEE TYP. "BLOW THRU" CONTAINMENT AND FALSEWORK DETAILS.

** INCLUDES MILLING OF ROADWAY PAVEMENT.

STATE OF NORTH CAROLINA
 DEPARTMENT OF TRANSPORTATION
 RALEIGH



GENERAL DRAWING
 BRIDGE #49 ON US13
 OVER ROQUIST CREEK

REVISIONS						SHEET NO.
NO.	BY:	DATE:	NO.	BY:	DATE:	S-18
1			3			TOTAL SHEETS
2			4			50

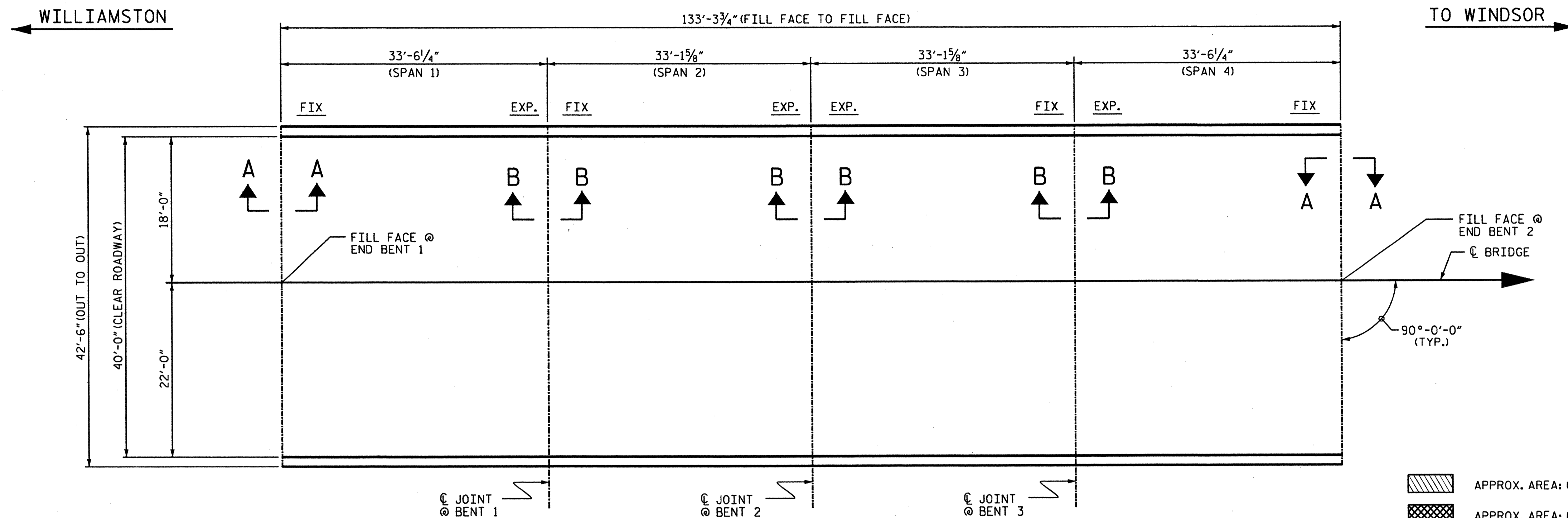
DRAWN BY : K.H. COMPTON DATE : 10/11
 CHECKED BY : D. SNOKE DATE : 10/11



PLAN OF SPANS- DECK REPAIRS
 ENTIRE DECK TO BE SCARIFIED AND HYDRODEMOLITION

 APPROX. AREA: CLASS II REPAIR
 APPROX. AREA: CLASS III REPAIR

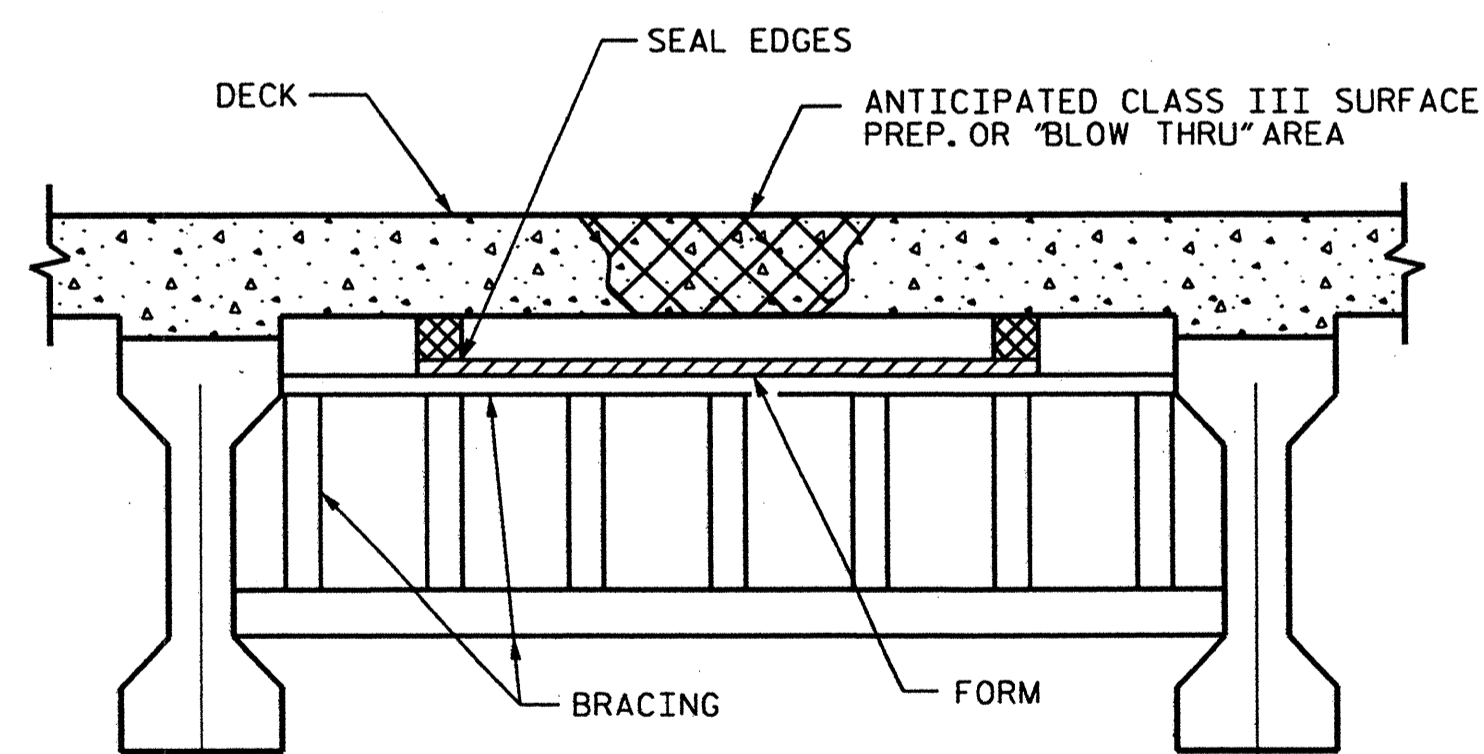

TYP. "BLOW THRU" CONTAINMENT AND FORMWORK

A METHOD TO CAPTURE WATER AND DEBRIS FROM BLOW THRU DURING HYDRO-DEMOLITION SHALL BE INSTALLED IN AREAS INDICATED AS CLASS III SURFACE PREPARATION.
 SUBMIT DETAILS OF PROPOSED FORMWORK FOR APPROVAL PRIOR TO BEGINNING WORK.
 COST FOR INSTALLING AND REMOVING FORMWORK SHALL BE INCIDENTAL TO THE PRICE PER SQ. YARD OF HYDRO-DEMOLITION.

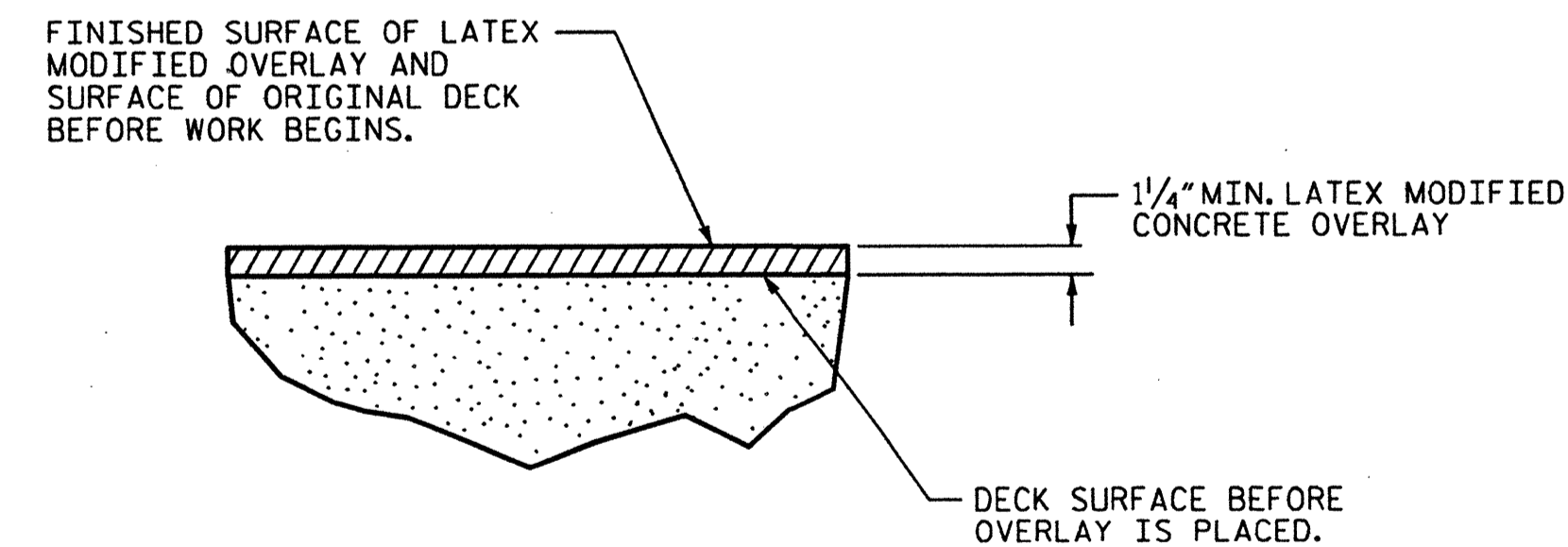

DETAIL FOR LATEX MODIFIED CONCRETE OVERLAY

PROJECT NO. 17BP.1.P.3
 COUNTY: BERTIE
 DECK REPAIR BRIDGE NO. 49
 SHEET 2 OF 7

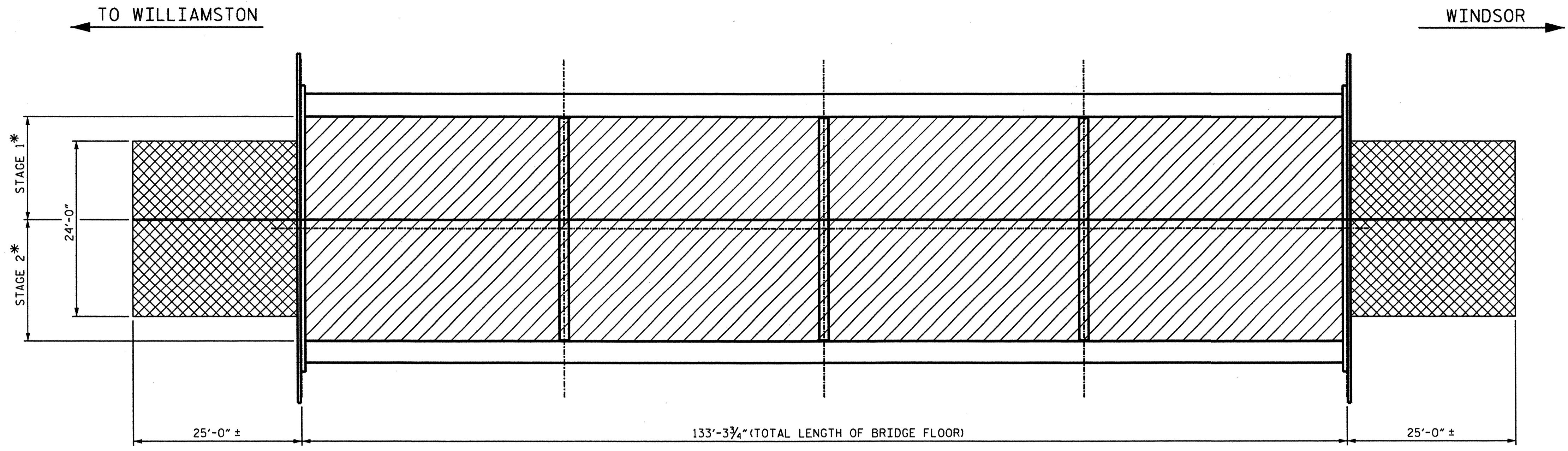

STATE OF NORTH CAROLINA						SHEET NO. S-19
DEPARTMENT OF TRANSPORTATION RALEIGH						
PLAN OF BRIDGE						
40'-0" CLEAR ROADWAY (90°-00' SKEW)						
REVISIONS						TOTAL SHEETS 50
NO.	BY:	DATE:	NO.	BY:	DATE:	
1			3			
2			4			

DRAWN BY : K.H. COMPTON DATE : 9/11
 CHECKED BY : D. SNOKE DATE : 9/11

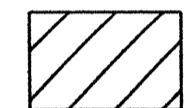

* SEE STAGING PLAN IN TRAFFIC CONTROL PLAN, SHEET TMP-4

PLAN

-  DECK SCARIFICATION AND HYDRODEMOLITION
-  MILLING OF ROADWAY APPROACH

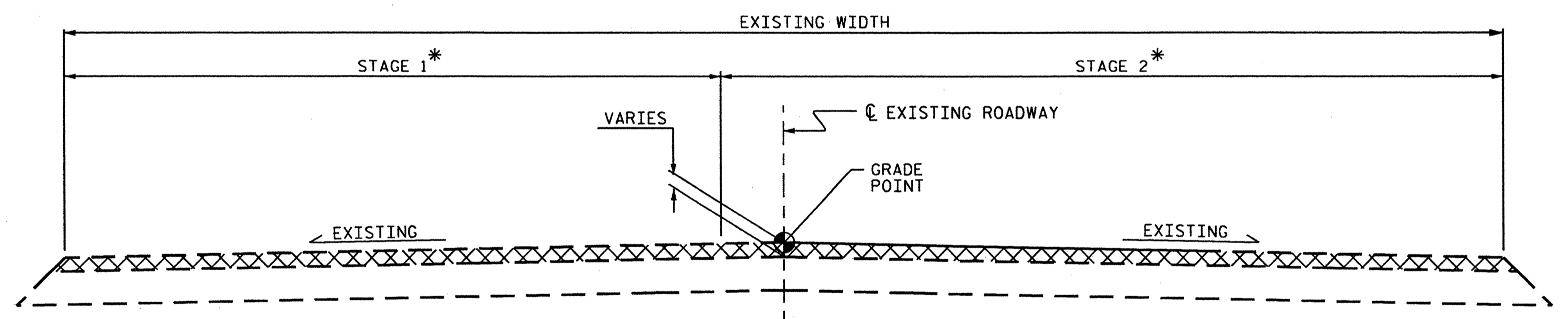

TYPICAL ROADWAY MILLING SECTION

C1 PROPOSED VARIABLE DEPTH ASPHALT CONCRETE SURFACE COURSE, TYPE SF 9.5B AT AN AVERAGE RATE OF 110 LBS. PER SQ. YD. PER 1" DEPTH, TO BE PLACED IN LAYERS NOT LESS THAN 1" IN DEPTH OR GREATER THAN 1/2" IN DEPTH.

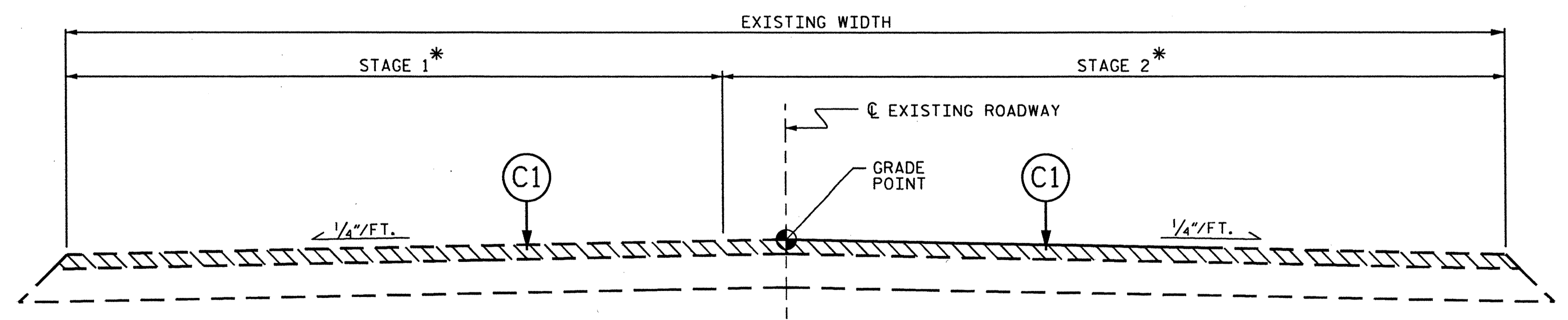

TYPICAL ROADWAY SECTION

PROJECT NO. 17BP.1.P.
 COUNTY: BERTIE
 DECK REPAIR BRIDGE NO. 49
 SHEET 3 OF 7

STATE OF NORTH CAROLINA
 DEPARTMENT OF TRANSPORTATION
 RALEIGH

TYPICAL ROADWAY SECTION AND MILLING DETAILS

DRAWN BY : K.H. COMPTON DATE : 9/11
 CHECKED BY : D. SNOKE DATE : 9/11

NOT TO SCALE

REVISIONS						SHEET NO.
NO.	BY:	DATE:	NO.	BY:	DATE:	S-20
1			3			TOTAL SHEETS
2			4			50

10-NOV-2011 10:09
 Z:\Squad\CDeck\Division 1\Proj01.dns\DKREHAB_070049.dgn
 dmiller

NOTES

EXISTING DECK DRAINS SHALL BE SEALED PRIOR TO BEGINNING REPAIR OF BRIDGE DECKS WITH LATEX MODIFIED CONCRETE. SEE SPECIAL PROVISIONS.

FOR HYDRO-DEMOLITION, SEE SPECIAL PROVISIONS.

THE CONTRACTOR MUST COLLECT, TREAT AND DISPOSE OF RUN-OFF WATER FROM THE HYDRO-DEMOLITION PROCESS, SEE SPECIAL PROVISIONS.

THE BOUNDARIES OF AREAS IDENTIFIED FOR CLASS III SURFACE PREPARATION ARE APPROXIMATE. THE CONTRACTOR SHALL PROVIDE A METHOD OF HANDLING UNEXPECTED BLOW THROUGH OF DECK. SEE DETAIL.

FOR OVERLAY OF BRIDGE DECKS WITH LATEX MODIFIED CONCRETE, SEE SPECIAL PROVISIONS.

SEE SPECIAL PROVISIONS FOR SURFACE PREPARATION.

EXISTING BRIDGE INFORMATION BASED ON BEST AVAILABLE DATA.

FOR FOAM JOINT SEAL SEE SPECIAL PROVISIONS.

THE INSTALLED FOAM JOINT SEAL SHALL BE WATER TIGHT.

NOMINAL UNCOMPRESSED SEAL WIDTH OF FOAM JOINT SEAL SHALL BE 2 1/2" AT BENTS.

THE CONTRACTOR WILL NOT BE PERMITTED TO FORM THE JOINT FOR THE FOAM JOINT SEAL IN LIEU OF SAWING THE JOINT

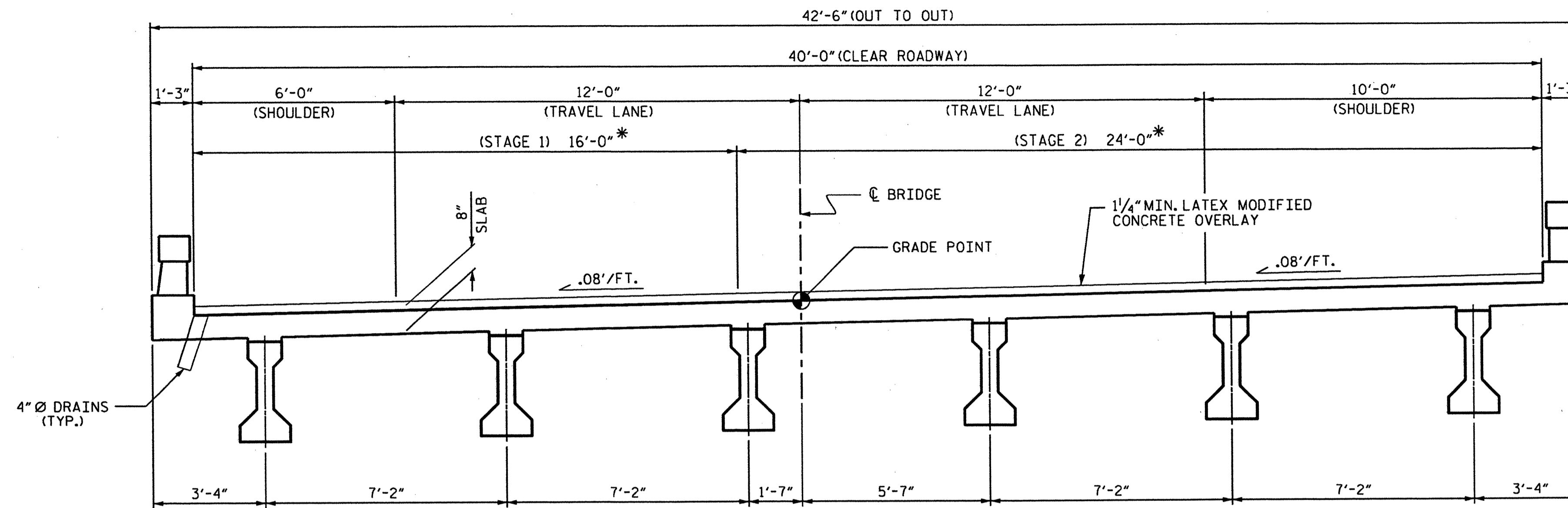

TYPICAL SECTION

* SEE STAGING PLAN IN TRAFFIC CONTROL PLAN, SHEET TMP-4

ELASTOMERIC CONCRETE	
BENTS	22.9 (CU. FT.)
END BENTS	0 (CU. FT.)
* TOTAL	22.9 (CU. FT.)

* BASED ON THE MINIMUM BLOCKOUT SHOWN.

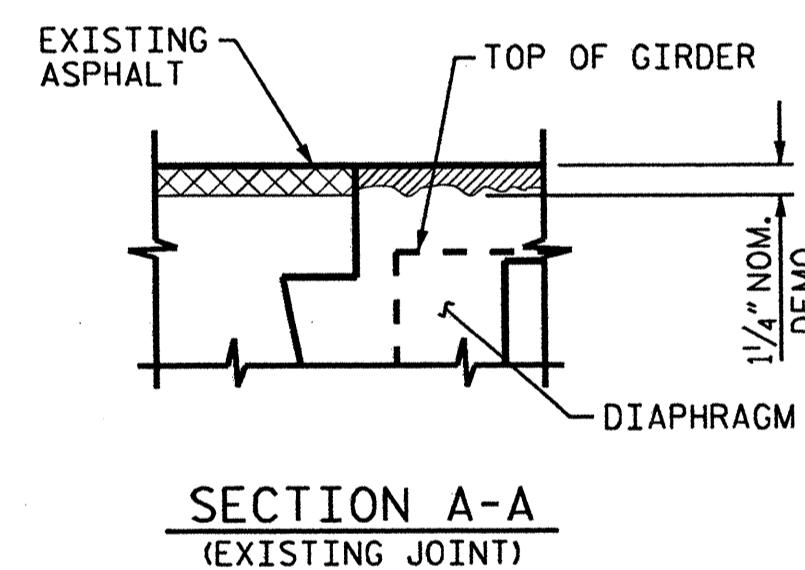

SECTION A-A
(EXISTING JOINT)

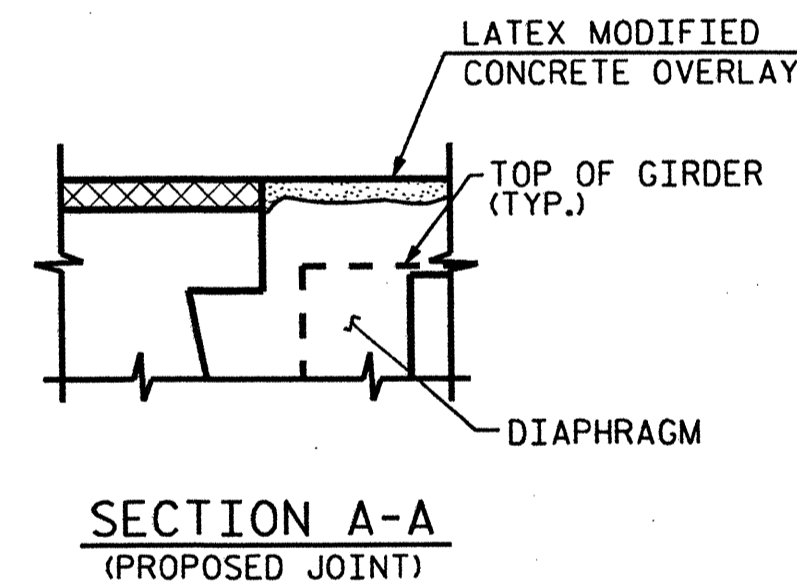

SECTION A-A
(PROPOSED JOINT)

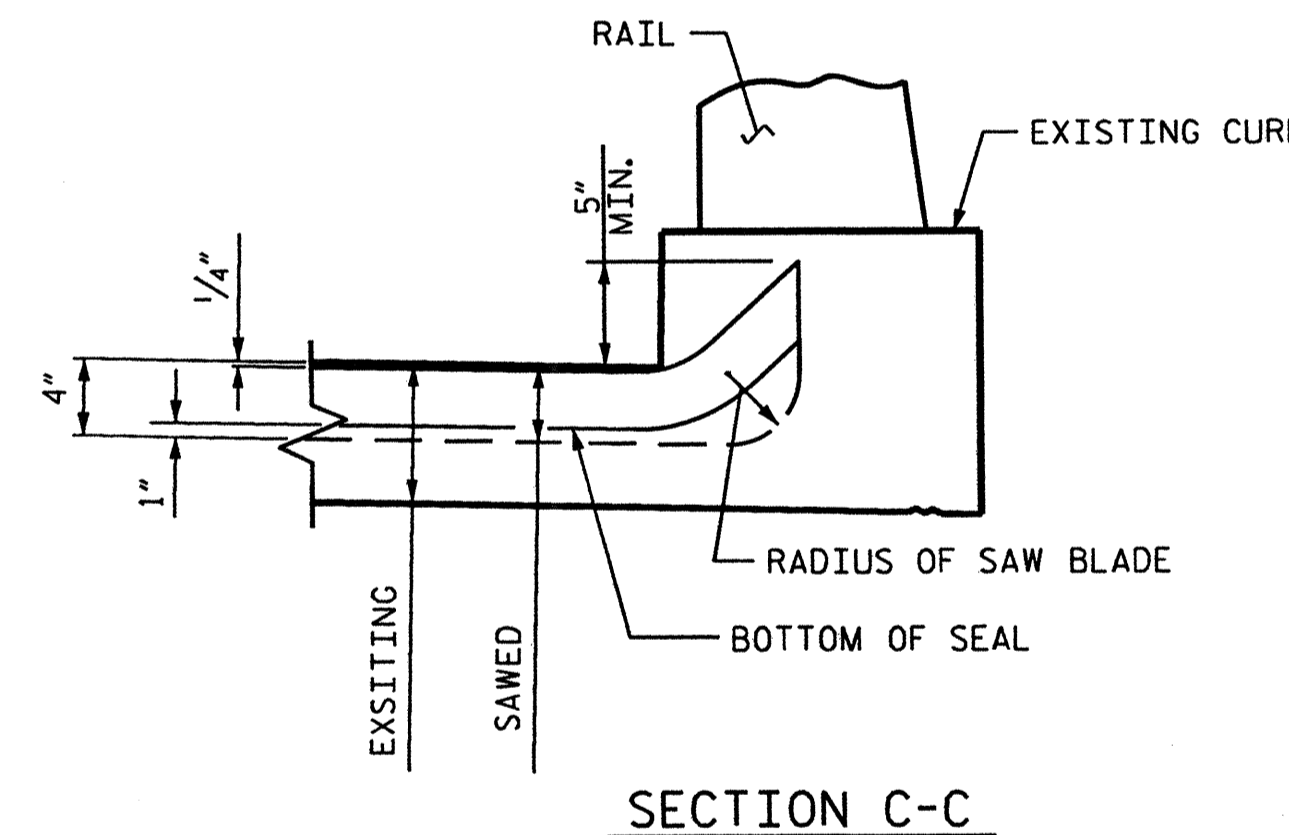

SECTION C-C

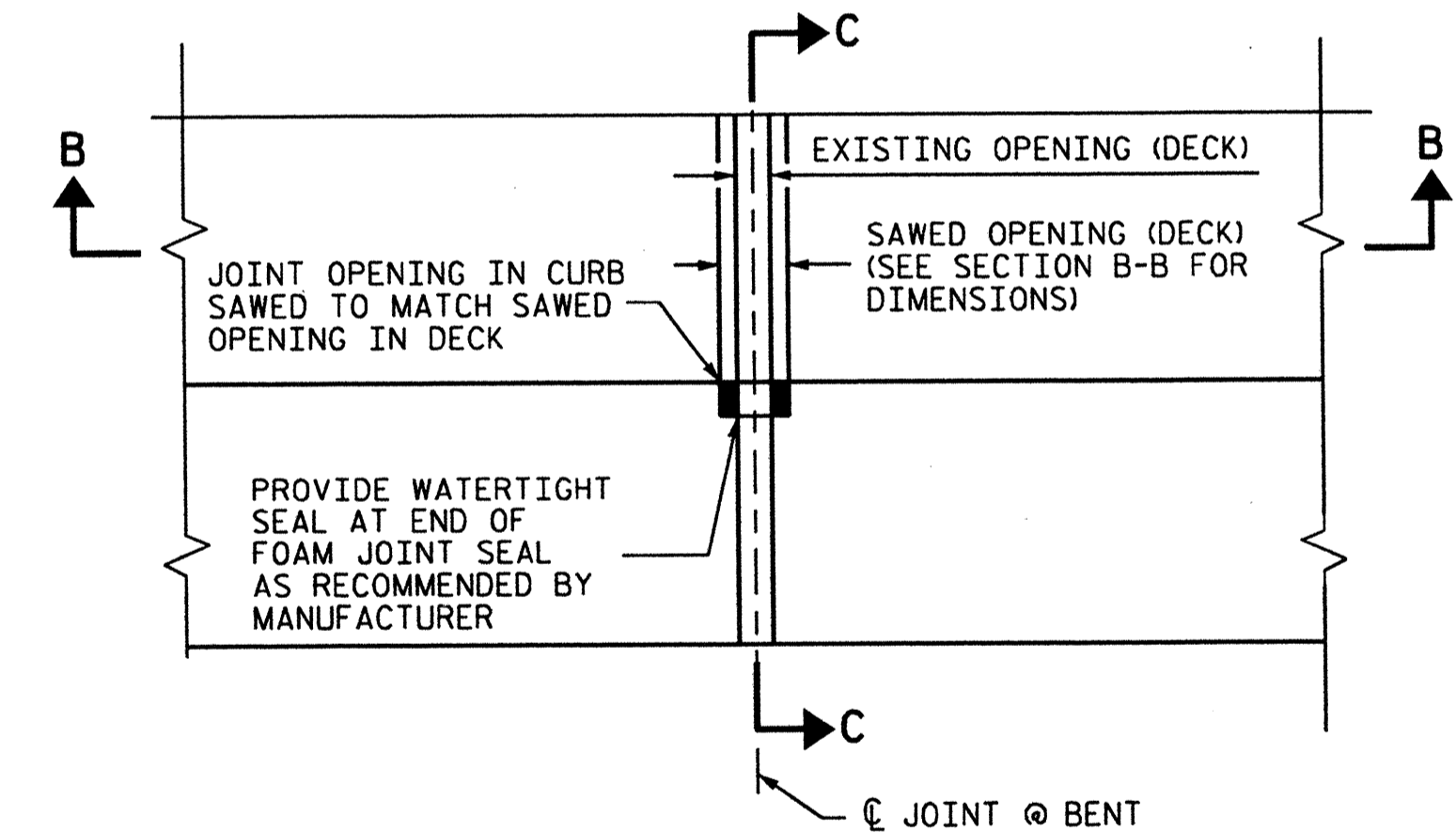

FOAM JOINT SEAL DETAILS

* SEAL WIDTH IN CURB TO BE DETERMINED BY THE ENGINEER

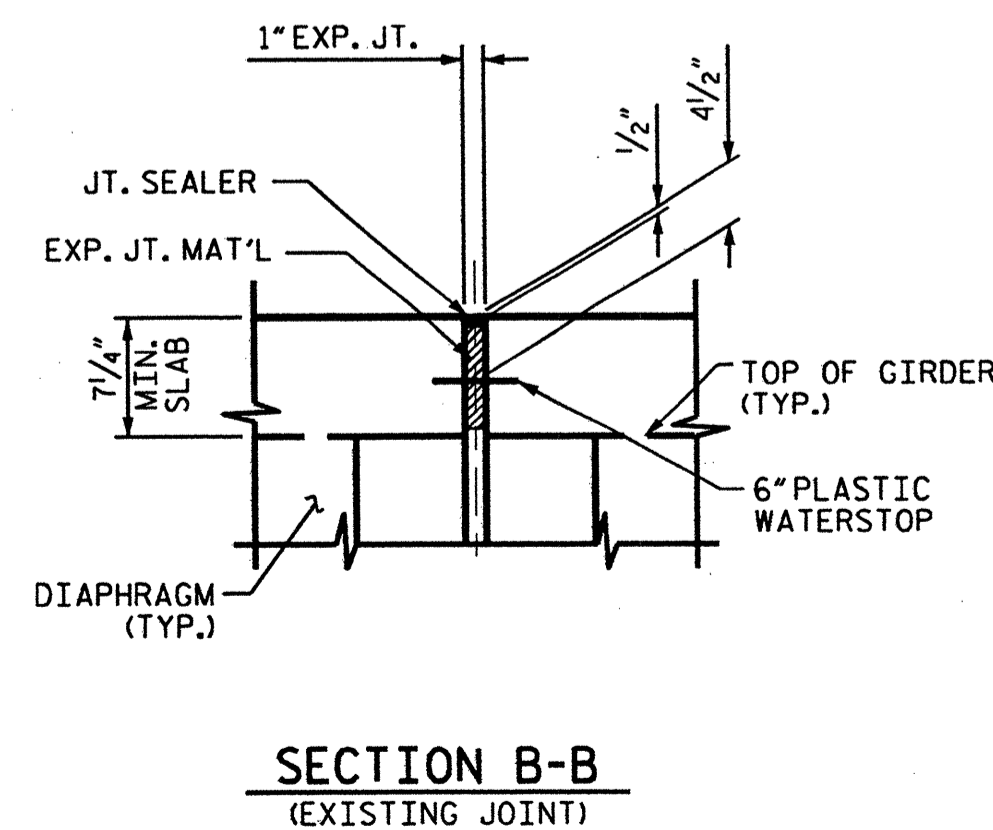

SECTION B-B
(EXISTING JOINT)

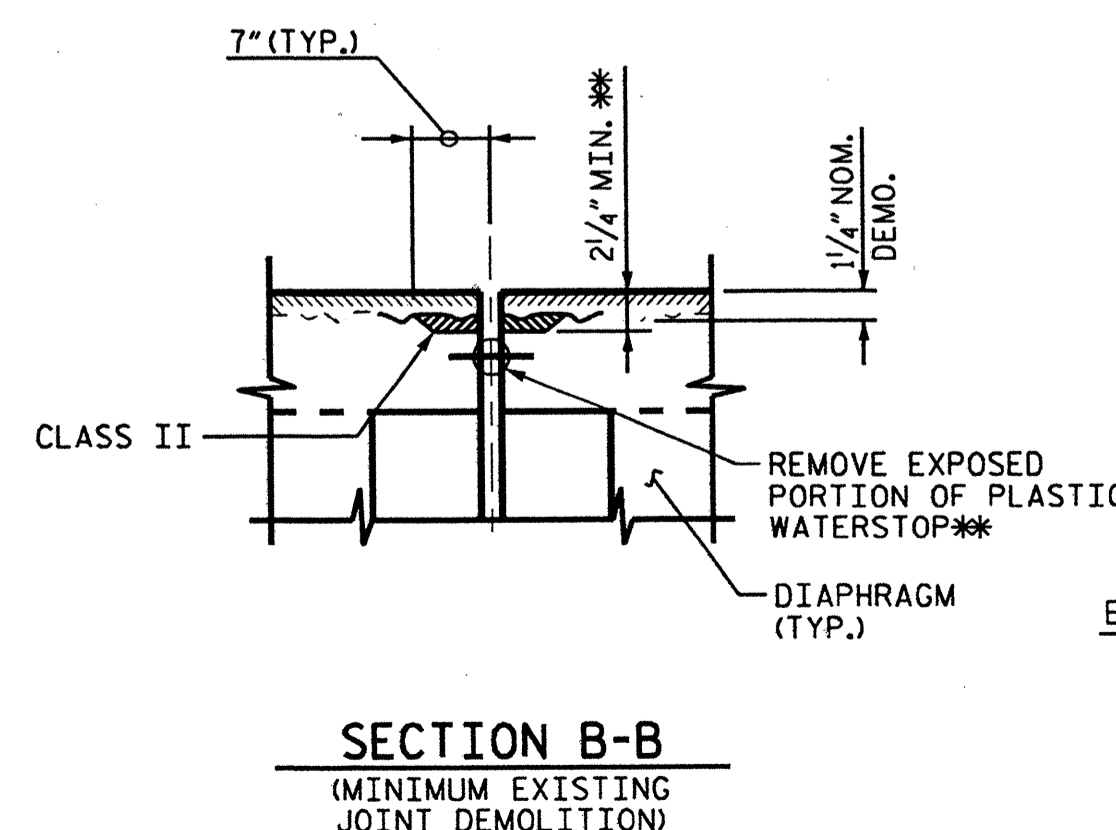

SECTION B-B
(MINIMUM EXISTING JOINT DEMOLITION)

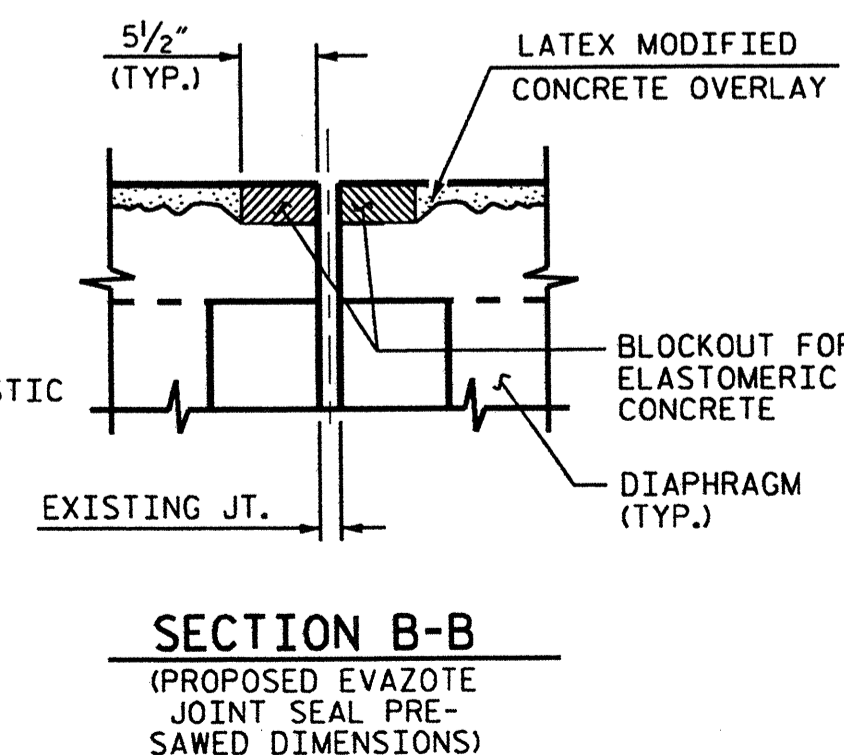

SECTION B-B
(PROPOSED EVAZOTE JOINT SEAL PRE-SAWED DIMENSIONS)

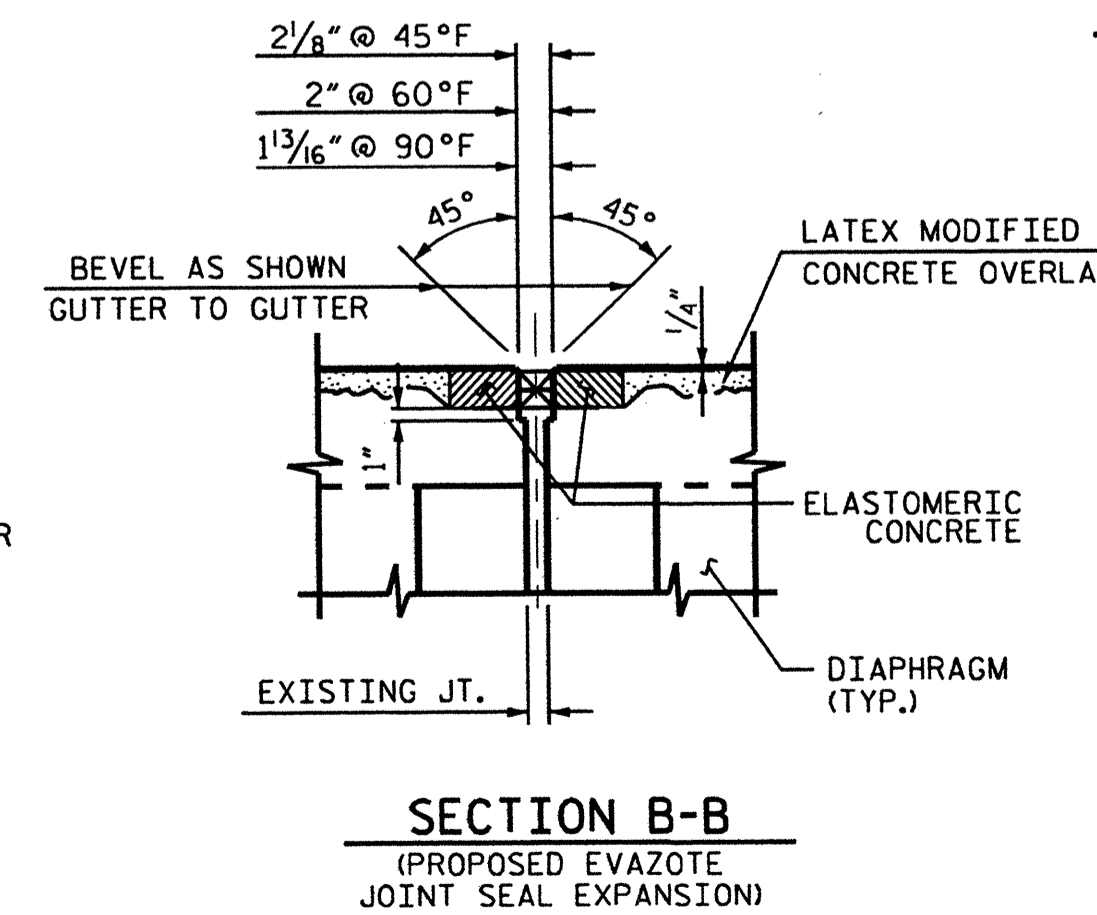

SECTION B-B
(PROPOSED EVAZOTE JOINT SEAL EXPANSION)

** ALL LOOSE AND UNSOUND CONCRETE SHALL BE REMOVED. IF THE EMBEDDED PORTION OF THE EXISTING PLASTIC WATERSTOP IS EXPOSED DURING REMOVAL OF UNSOUND CONCRETE, THE ENTIRE WATERSTOP SHALL BE REMOVED.

PROJECT NO. 17BP.1.P.3
 COUNTY: BERTIE
 DECK REPAIR BRIDGE NO. 49
 SHEET 4 OF 7

STATE OF NORTH CAROLINA
 DEPARTMENT OF TRANSPORTATION
 RALEIGH

TYPICAL SECTION AND JOINT DETAILS

REVISIONS						SHEET NO.
NO.	BY:	DATE:	NO.	BY:	DATE:	S-21
1			3			TOTAL SHEETS
2			4			50

DRAWN BY : K.H. COMPTON DATE : 9/11
 CHECKED BY : D. SNOKE DATE : 9/11

NOTES

1. FOR EXAMPLES OF TYPICAL ENCAPSULATION OF PILES SEE SHEETS #23 AND #24.
2. REPAIR OF THE BRIDGE SHALL BE PERFORMED SO AS NOT TO ALLOW DEBRIS TO FALL INTO THE WATER.

PILE ENCAPSULATION LOCATIONS

BENT	PILE	LF
1	ALL	21.9
2	ALL	55.5
3	ALL	61.1
TOTAL	24	139

PILE ENCAPSULATION LENGTHS INCLUDE 1'-0" ABOVE DAMAGED AREA AND 1'-0" BELOW MUD LINE.
 QUANTITIES ARE BASED ON BEST AVAILABLE INFORMATION.

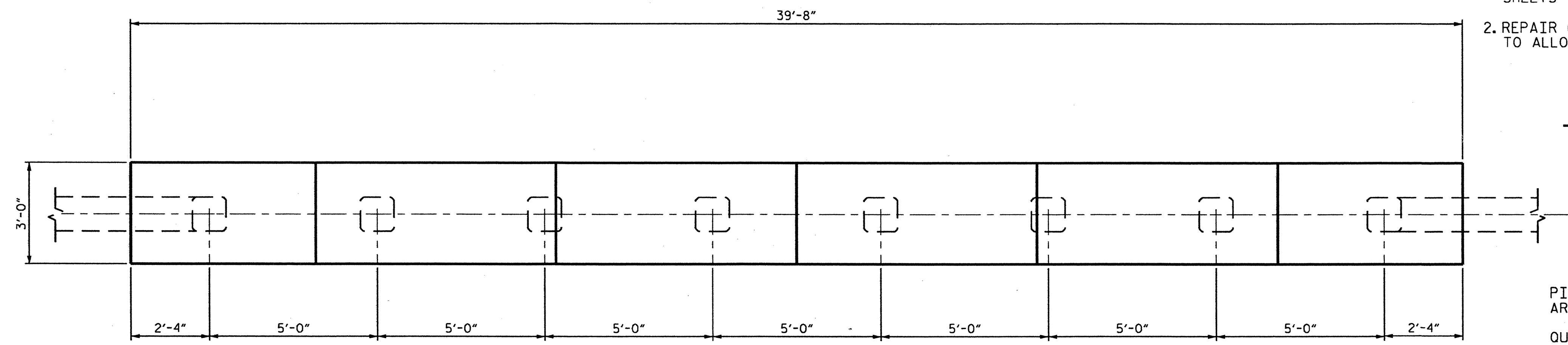

PLAN OF BENT No. 1
 (BENT No. 2 & 3 SIMILAR)

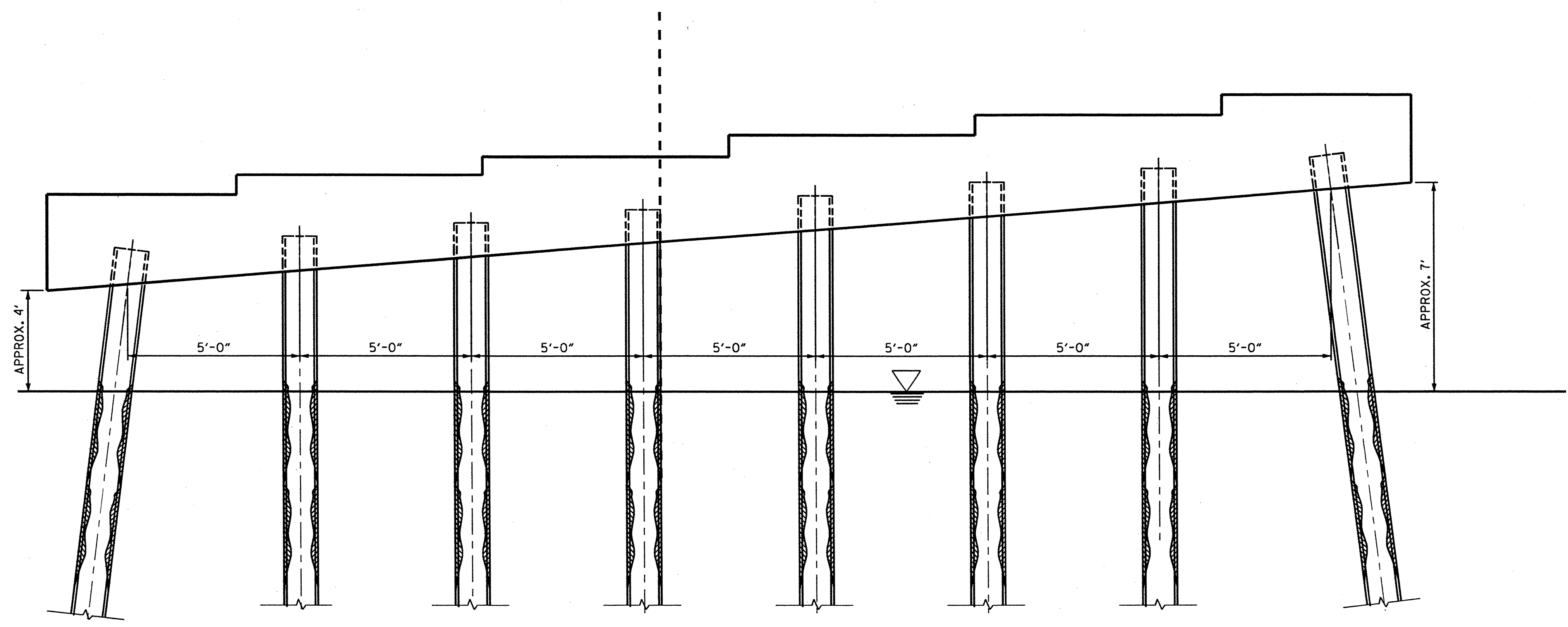

ELEVATION VIEW BENT No. 1
 (BENT No. 2 & 3 SIMILAR)

PROJECT NO. 17BP.1.P.3
 COUNTY: BERTIE
 DECK REPAIR BRIDGE NO. 49
 SHEET 5 OF 7

STATE OF NORTH CAROLINA
 DEPARTMENT OF TRANSPORTATION
 RALEIGH

BENT REPAIRS

REVISIONS						SHEET NO.
NO.	BY:	DATE:	NO.	BY:	DATE:	S-22
1			3			TOTAL SHEETS
2			4			50

BENTS #1, #2 AND #3

DRAWN BY : K.H. COMPTON DATE : 10/11
 CHECKED BY : D. SNOKE DATE : 10/11

10-NOV-2011 10:09
 Z:\Squad_C\Deck\Division 1\Proj01.dns\DKREHAB_070049.dgn
 dmuller

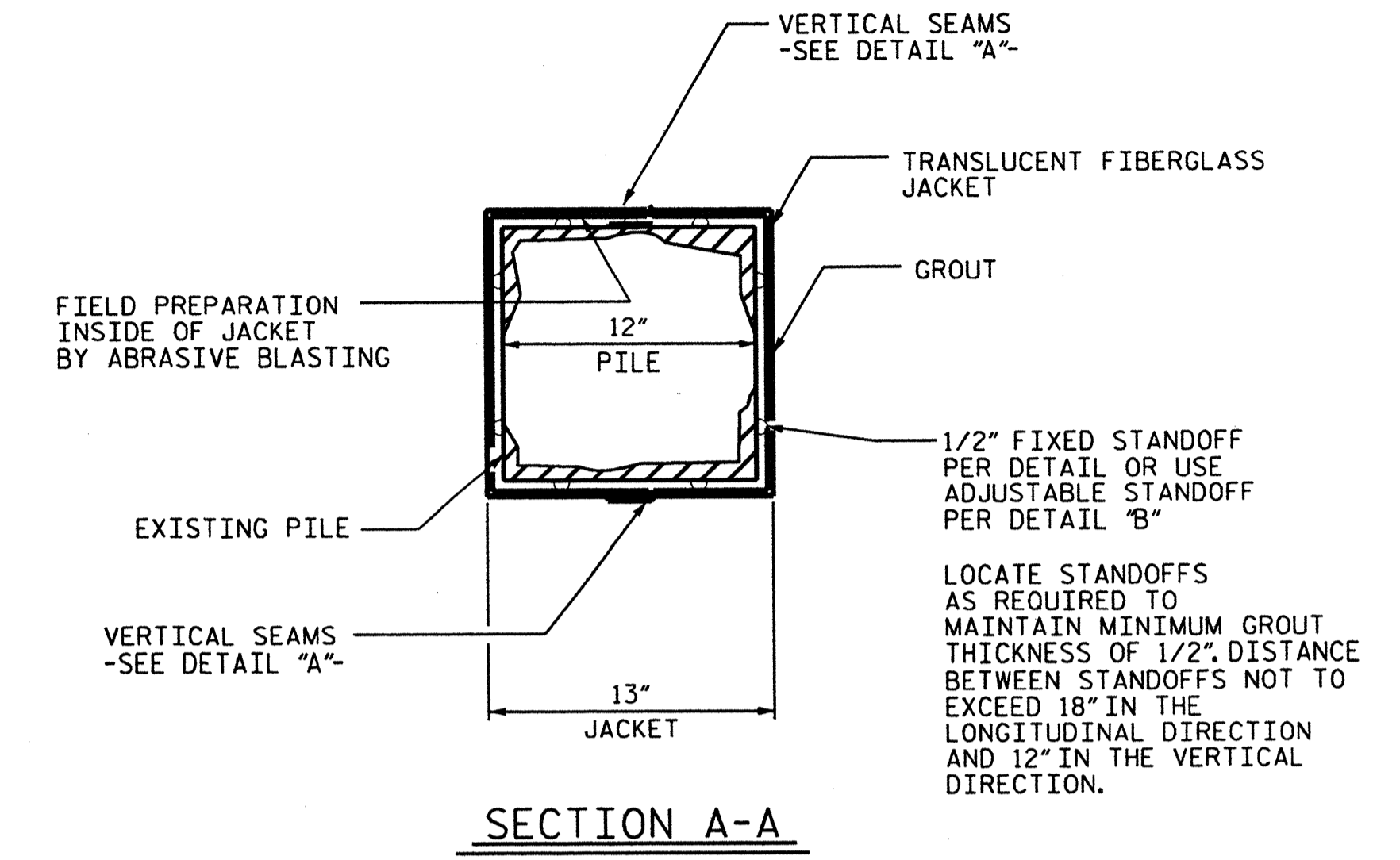
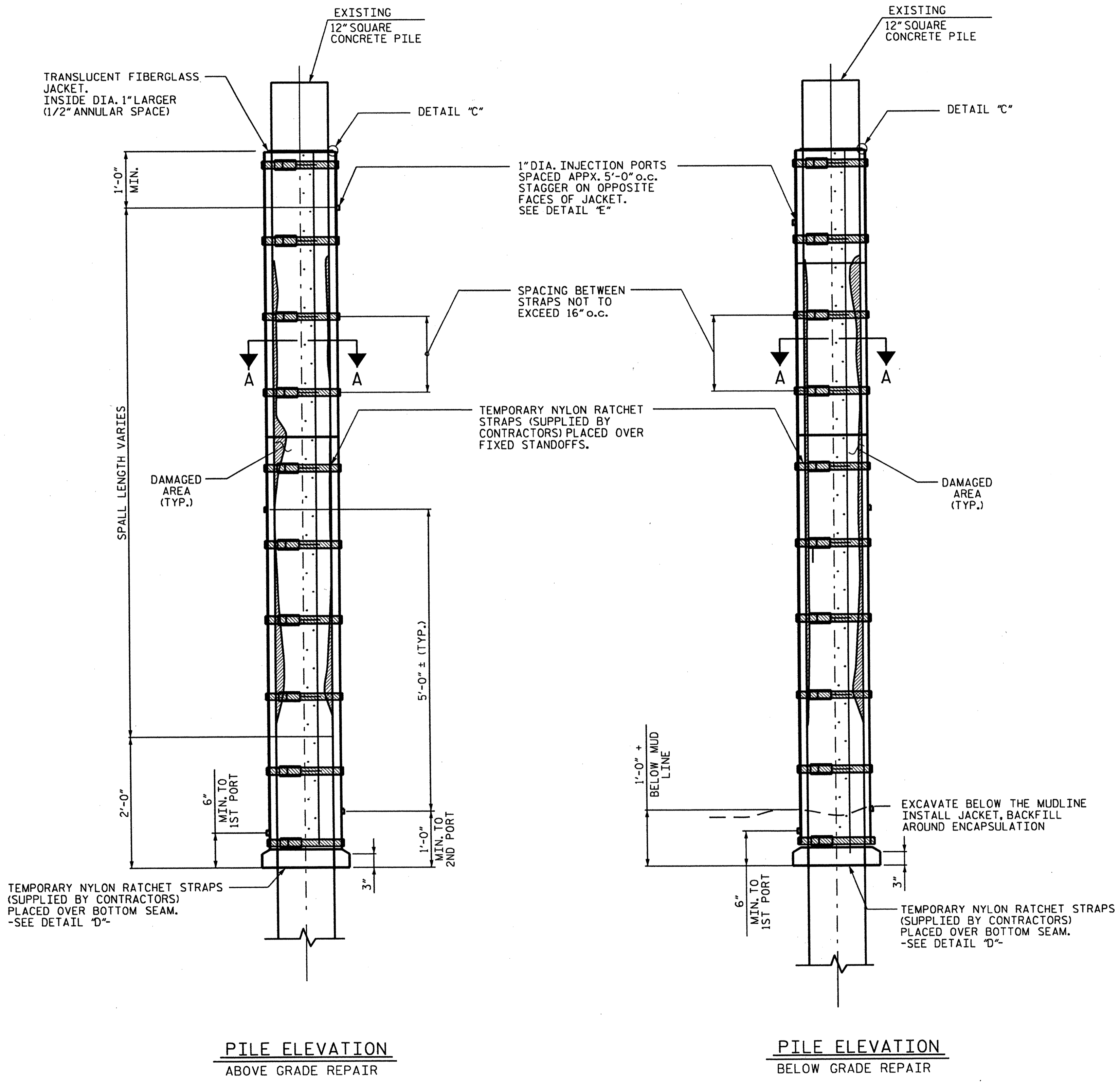

- REPAIR SEQUENCES**
1. AFTER SURFACE PREPARATION, PLACE JACKET IN PROPER LOCATION AROUND PILE AND SEAL LONGITUDINAL SEAMS (SEE DETAIL "A"). INSTALL TEMPORARY BRACING.
 2. CONFIRM SPACING BETWEEN JACKET AND PILE. INSTALL BOTTOM SEAL (SEE DETAIL "D"). ALLOW BOTTOM SEAL TO CURE APPX. 4 HOURS.
 3. ATTACH GROUT HOSE TO LOWERMOST INJECTION PORT AND PUMP A-P-E GROUT FOR 30-sec. CHECK FOR LEAKS ALONG SEAMS AND BOTTOM SEAL. (OPTIONALLY ALLOW THIS GROUT TO CURE AND PROCEED WITH GROUT INJECTION FROM 2nd PORT.)
 4. PLUG UPPER INJECTION PORTS AND PUMP GROUT INTO LOWER PORT UNTIL GROUT REACHES TOP OF JACKET. ONLY USE UPPER PORTS IF INJECTION BECOMES DIFFICULT.

PROJECT NO. 17BP.1.P.3
 COUNTY: BERTIE
 DECK REPAIR BRIDGE NO. 49
 SHEET 6 OF 7

STATE OF NORTH CAROLINA DEPARTMENT OF TRANSPORTATION RALEIGH					
SQUARE PILE ENCAPSULATION					
REVISIONS					
NO.	BY:	DATE:	NO.	BY:	DATE:
1			3		
2			4		
					SHEET NO. S-23
					TOTAL SHEETS 50

DRAWN BY : K.H. COMPTON DATE : 10/11
 CHECKED BY : D. SNOKE DATE : 10/11

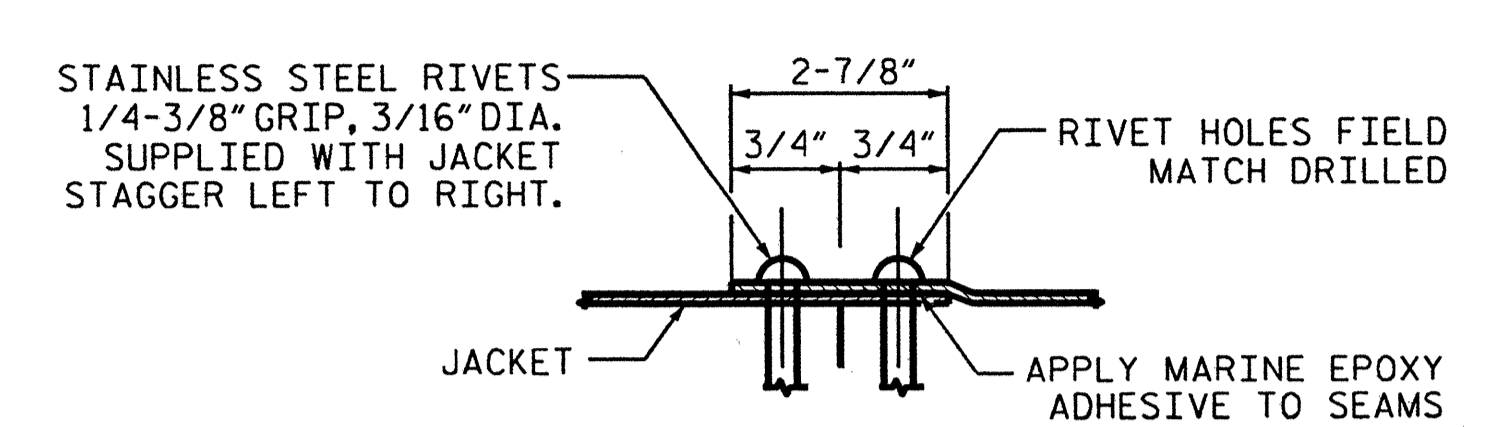
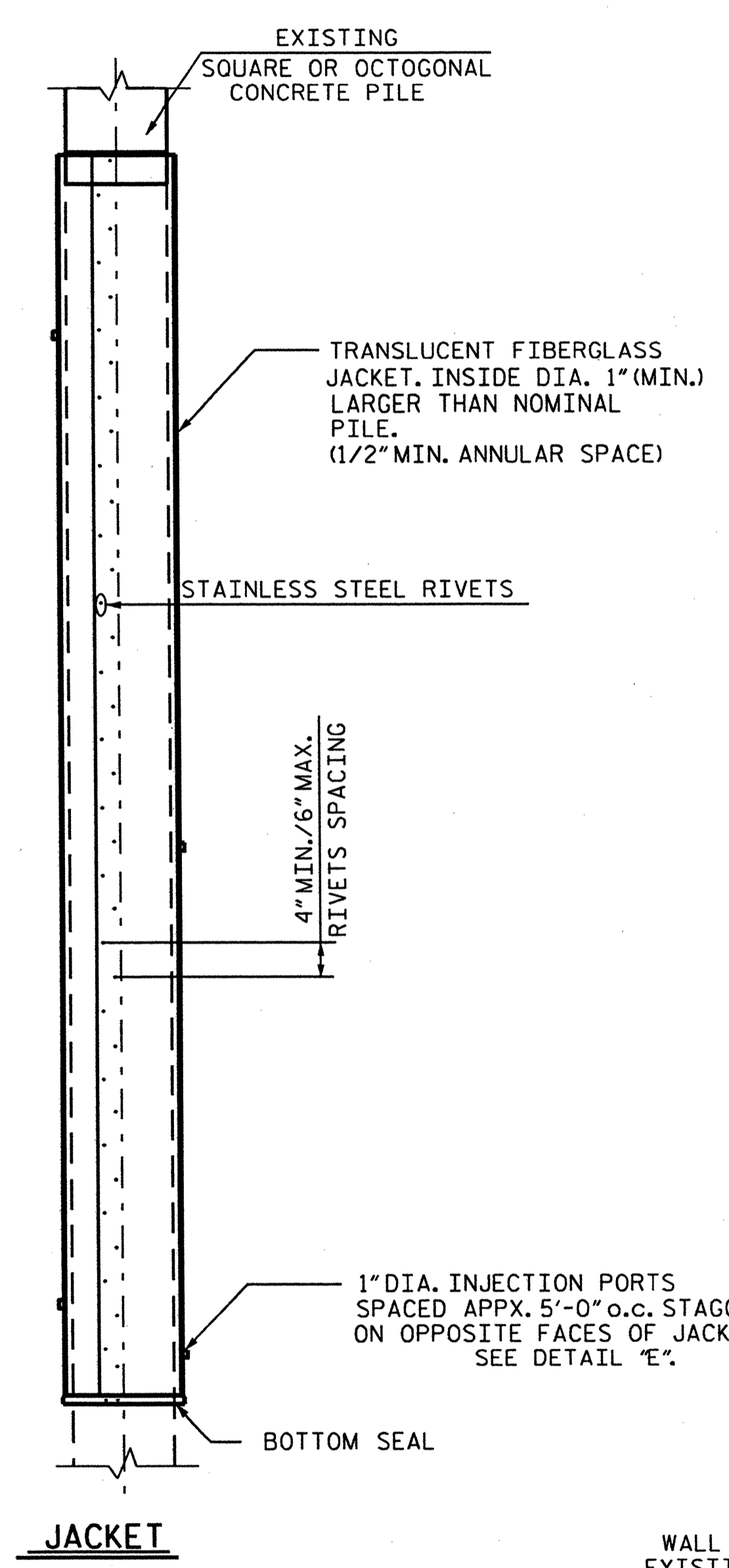

DETAIL A
SEAM DETAIL

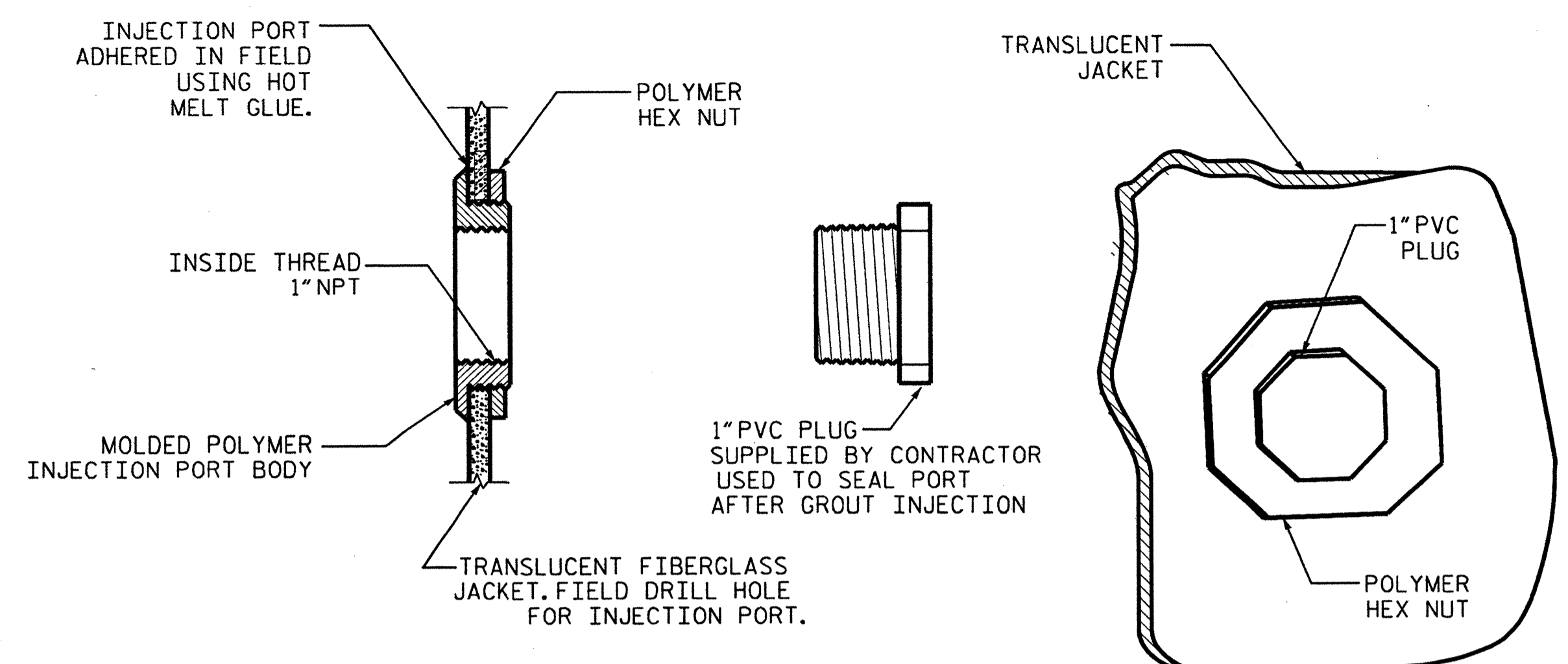

SECTION THRU PORT

ISOMETRIC VIEW

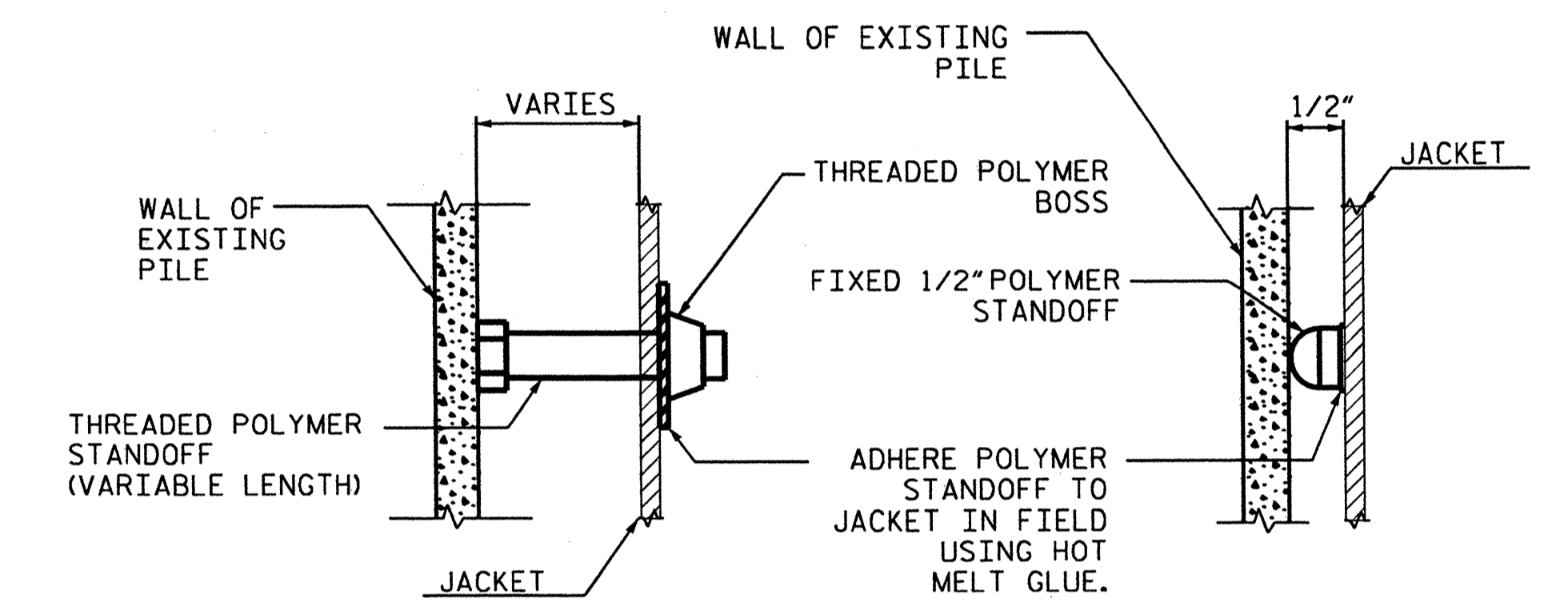

ADJUSTABLE STANDOFF DETAIL

FIXED STANDOFF DETAIL

DETAIL B

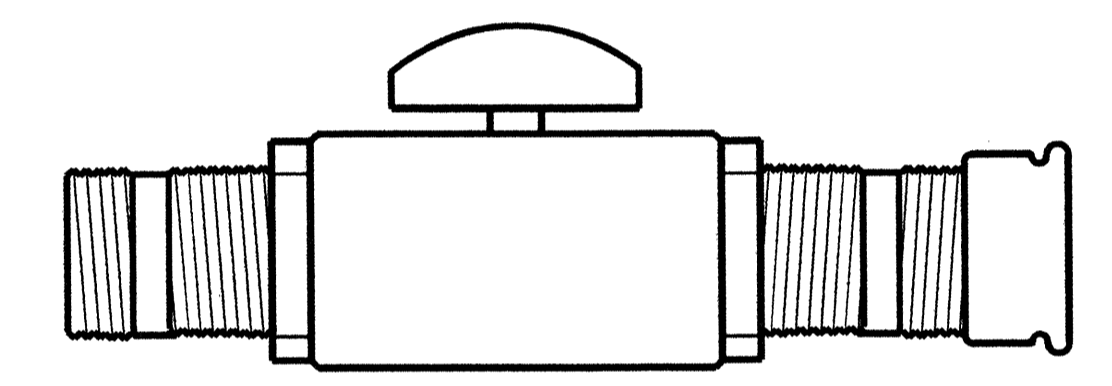

DETAIL E

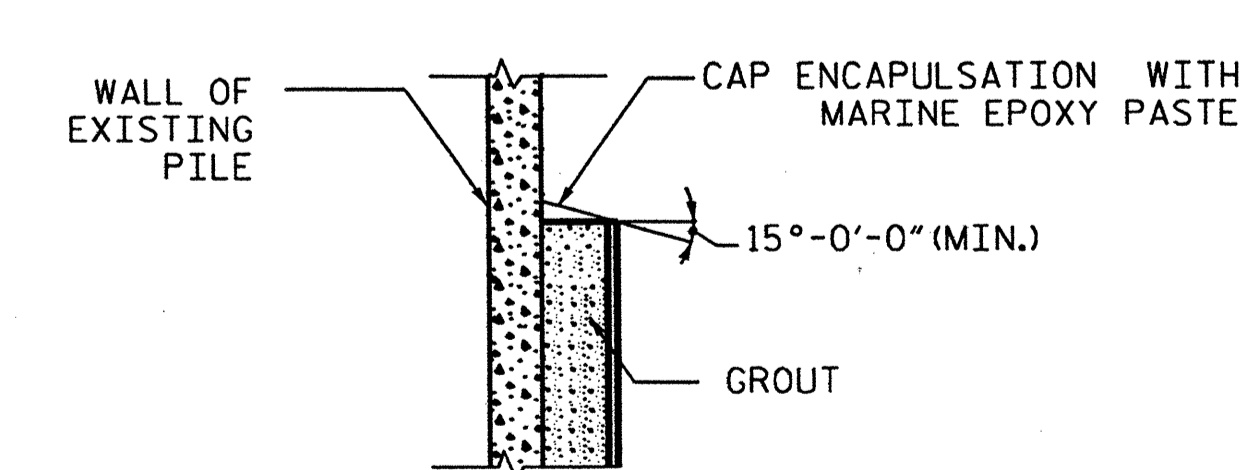

DETAIL C
-TOP OF JACKET-

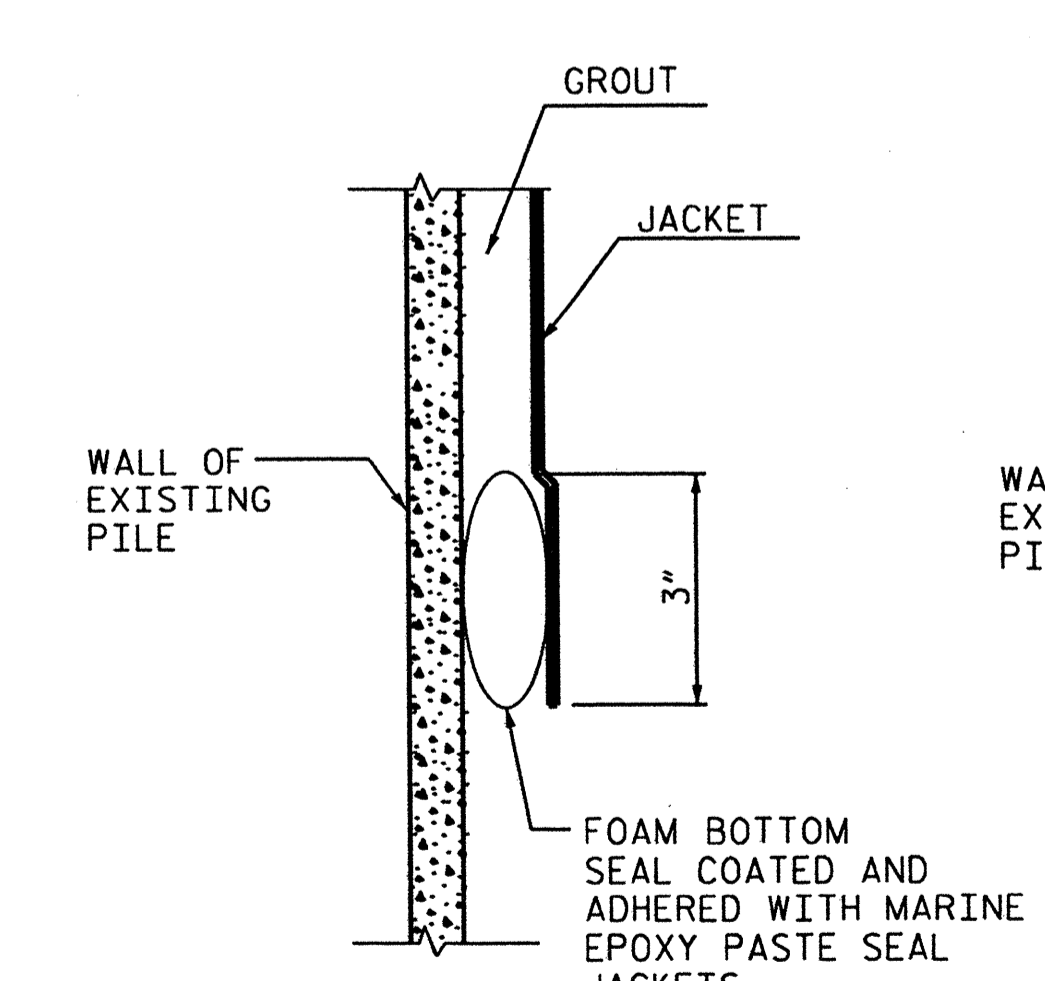

BOTTOM SEAL DETAIL

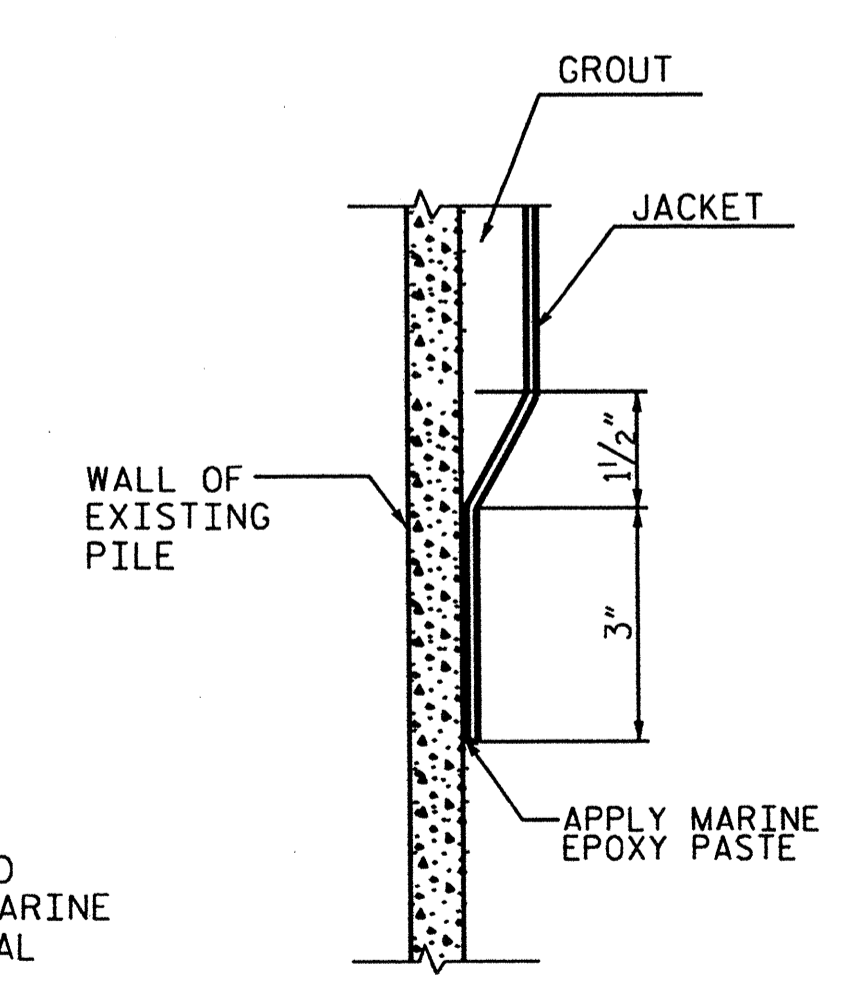

ALT. BOTTOM SEAL DETAIL

DETAIL D

PROJECT NO. 17BP.1.P.3
 COUNTY: BERTIE
 DECK REPAIR BRIDGE NO. 49
 SHEET 7 OF 7

STATE OF NORTH CAROLINA DEPARTMENT OF TRANSPORTATION RALEIGH						SHEET NO. S-24
PILE ENCAPSULATION DETAILS						TOTAL SHEETS 50
REVISIONS						NO.
NO.	BY:	DATE:	NO.	BY:	DATE:	
1			3			4
2			4			

DRAWN BY : K.H. COMPTON DATE : 10/11
 CHECKED BY : D. SNOKE DATE : 10/11

10-NOV-2011 10:09
 Z:\Squad C\Deck\Division 1\Proj01.dns\DKREHAB_070049.dgn
 dmuller

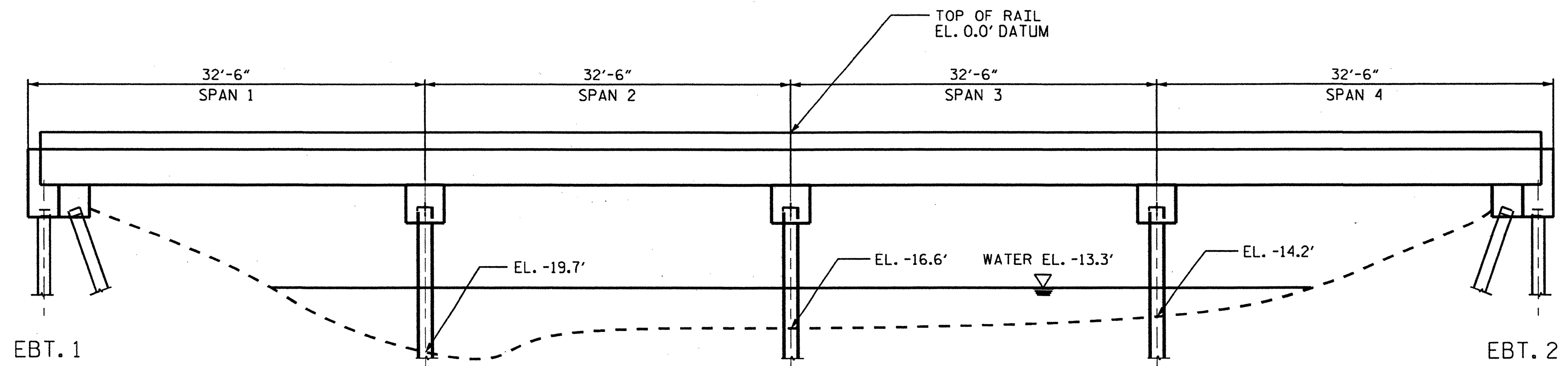

PROFILE OF BRIDGE

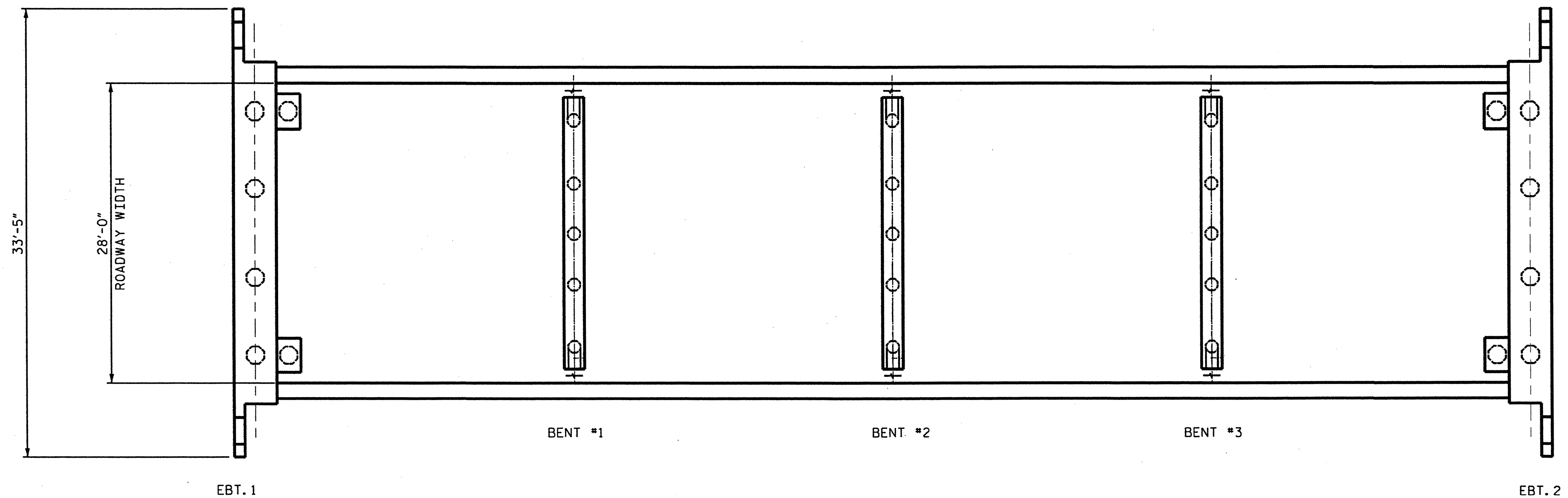

PLAN OF BRIDGE

TOTAL BILL OF MATERIAL

DECK** SCARIFICATION	CLASS I* SURFACE PREPARATION	CLASS II* SURFACE PREPARATION	CLASS III* SURFACE PREPARATION	HYDRO- DEMOLITION OF BRIDGE DECK	LATEX MODIFIED CONCRETE	PLACING & FINISHING LATEX MODIFIED CONCRETE	FOAM JOINT SEALS	GROOVING BRIDGE FLOORS	ASPHALT CONC. SURF. COURSE TYPE S9.5B	PILE ENCAPSULATION
SQ.YDS.	SQ.YDS.	SQ.YDS.	SQ.YDS.	SQ.YDS.	C.Y.	SQ.YDS.	LUMP SUM	SQ. FT.	TON	LF
404	0	0	0	404	16.9	404	LUMP SUM	3,100	0	83

* QUANTITIES ARE SHOWN FOR INFORMATIONAL PURPOSES ONLY. IF ANY CLASS III LOCATIONS ARE ENCOUNTERED PRIOR TO OR DURING HYDRO-DEMOLITION, SEE TYP. "BLOW THRU" CONTAINMENT AND FALSEWORK DETAILS.

** INCLUDES MILLING OF ROADWAY PAVEMENT.

DRAWN BY : K.H. COMPTON DATE : 10/11
 CHECKED BY : D. SNOKE DATE : 10/11

10-NOV-2011 10:09
 Z:\Squad C\Deck\Division 1\Proj01.dns\DKREHAB_070050.dgn
 cmuller

PROJECT NO. 17BP.1.P.3

COUNTY: BERTIE

DECK REPAIR BRIDGE NO. 50

SHEET 1 OF 7

STATE OF NORTH CAROLINA
 DEPARTMENT OF TRANSPORTATION
 RALEIGH

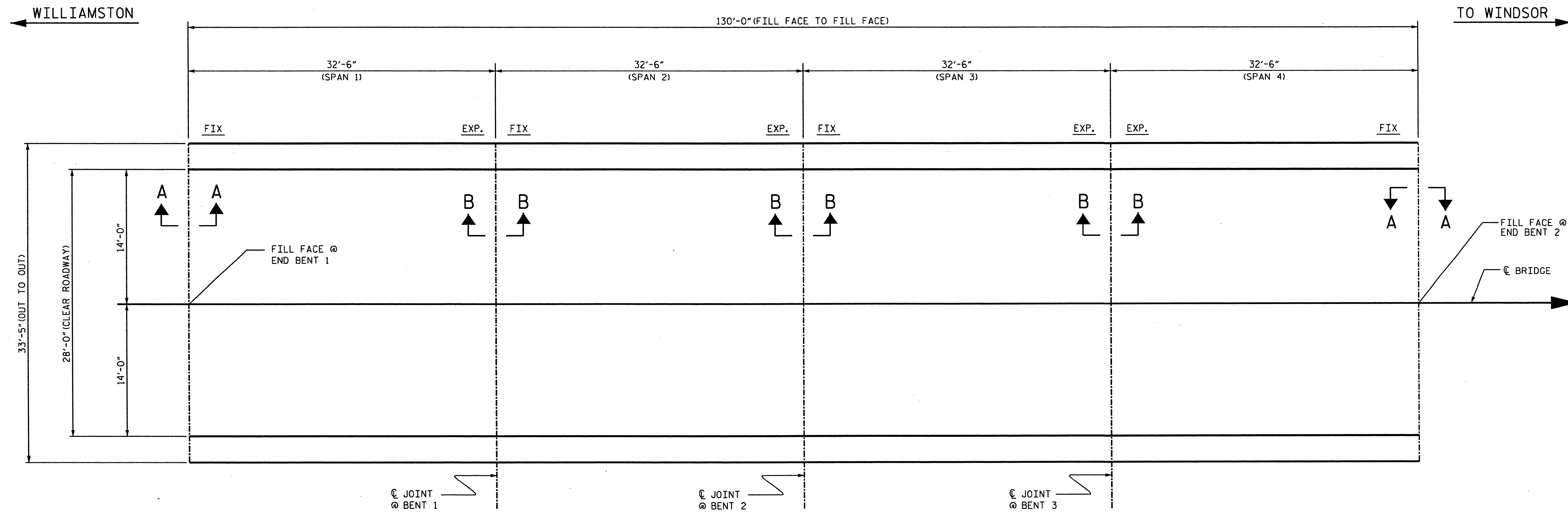

GENERAL DRAWING
 BRIDGE #49 ON US13
 OVER ROQUIST CREEK

REVISIONS						SHEET NO.
NO.	BY:	DATE:	NO.	BY:	DATE:	S-25
1			3			TOTAL SHEETS
2			4			50



PLAN OF SPANS- DECK REPAIRS

ENTIRE DECK TO BE SCARIFIED AND HYDRODEMOLITION

 APPROX. AREA: CLASS II REPAIR
 APPROX. AREA: CLASS III REPAIR

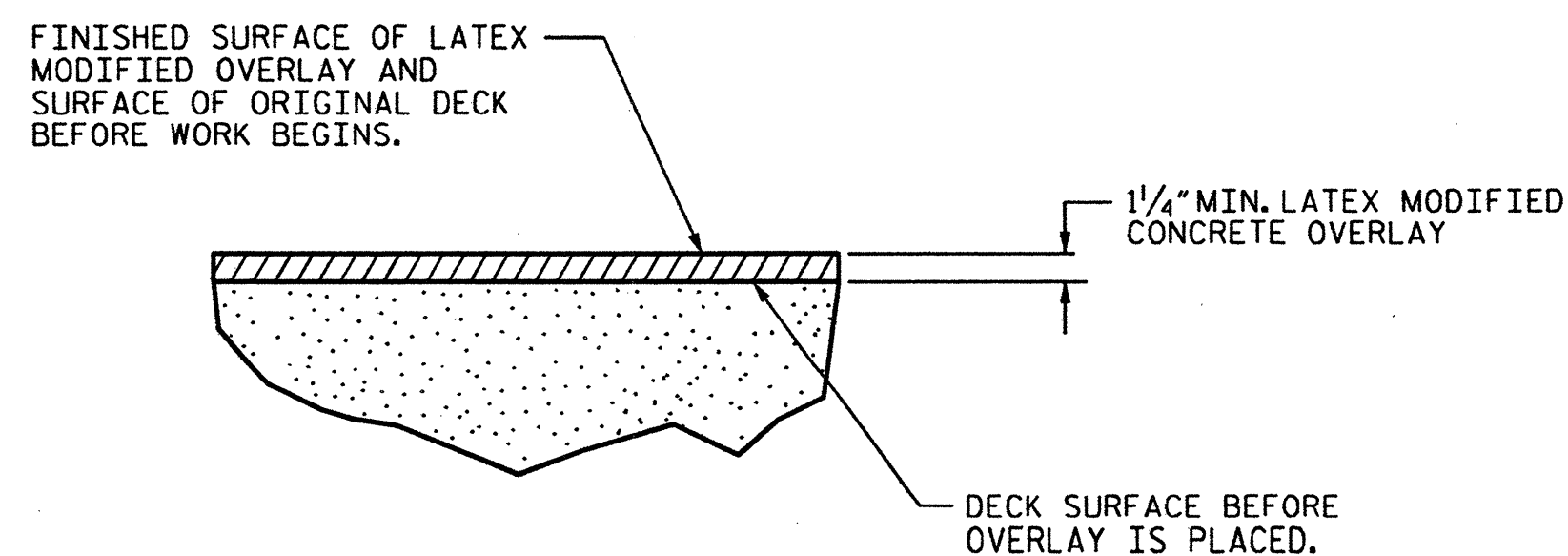

DETAIL FOR LATEX MODIFIED CONCRETE OVERLAY

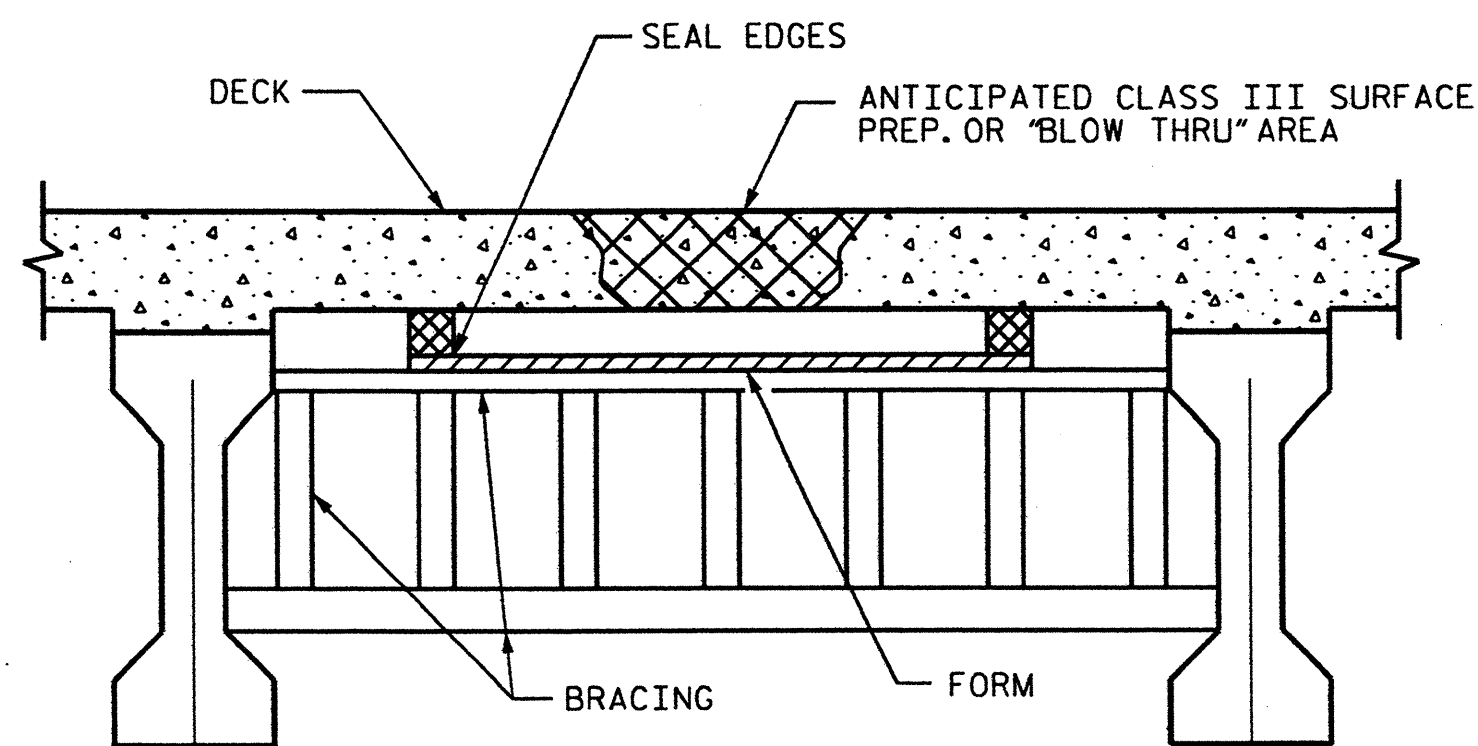

TYP. "BLOW THRU" CONTAINMENT AND FORMWORK

A METHOD TO CAPTURE WATER AND DEBRIS FROM BLOW THRU DURING HYDRO-DEMOLITION SHALL BE INSTALLED IN AREAS INDICATED AS CLASS III SURFACE PREPARATION.
 SUBMIT DETAILS OF PROPOSED FORMWORK FOR APPROVAL PRIOR TO BEGINNING WORK.
 COST FOR INSTALLING AND REMOVING FORMWORK SHALL BE INCIDENTAL TO THE PRICE PER SQ. YARD OF HYDRO-DEMOLITION.

PROJECT NO. 17BP.1.P.3
 COUNTY: BERTIE
 DECK REPAIR BRIDGE NO: 50
 SHEET 2 OF 7

STATE OF NORTH CAROLINA DEPARTMENT OF TRANSPORTATION RALEIGH					
PLAN OF BRIDGE					
28'-0" CLEAR ROADWAY (90°-00' SKEW)					
REVISIONS					
NO.	BY:	DATE:	NO.	BY:	DATE:
1			3		
2			4		
SHEET NO.					S-26
TOTAL SHEETS					50

DRAWN BY : K.H. COMPTON DATE : 9/11
 CHECKED BY : D. SNOKE DATE : 9/11

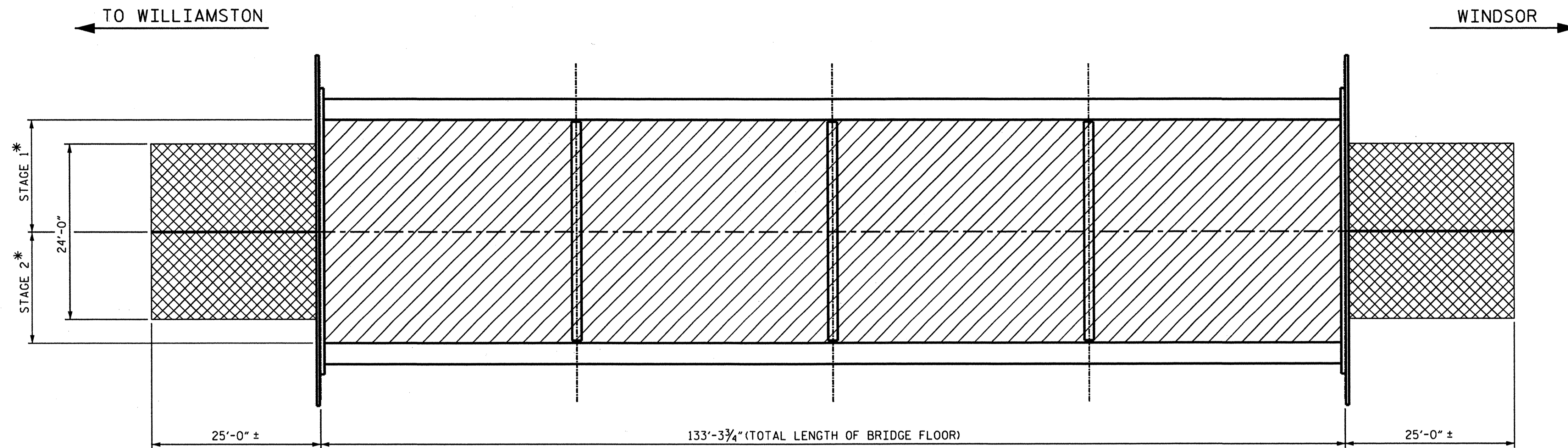

*SEE STAGING PLAN IN TRAFFIC CONTROL PLAN, SHEET TMP-4

PLAN

- DECK SCARIFICATION AND HYDRODEMOLITION
- MILLING OF ROADWAY APPROACH

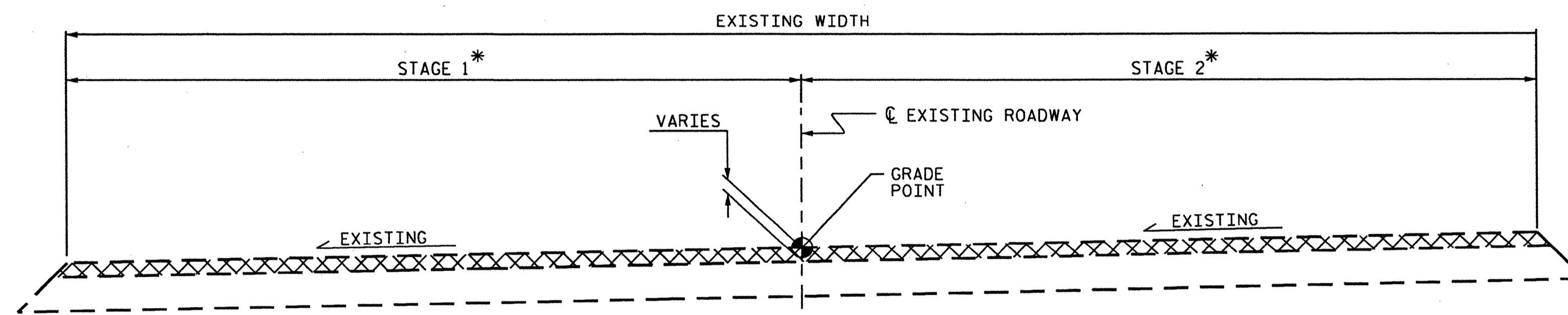

TYPICAL ROADWAY MILLING SECTION

C1 PROPOSED VARIABLE DEPTH ASPHALT CONCRETE SURFACE COURSE, TYPE SF 9.5B AT AN AVERAGE RATE OF 110 LBS. PER SQ. YD. PER 1" DEPTH. TO BE PLACED IN LAYERS NOT LESS THAN 1" IN DEPTH OR GREATER THAN 1 1/2" IN DEPTH.

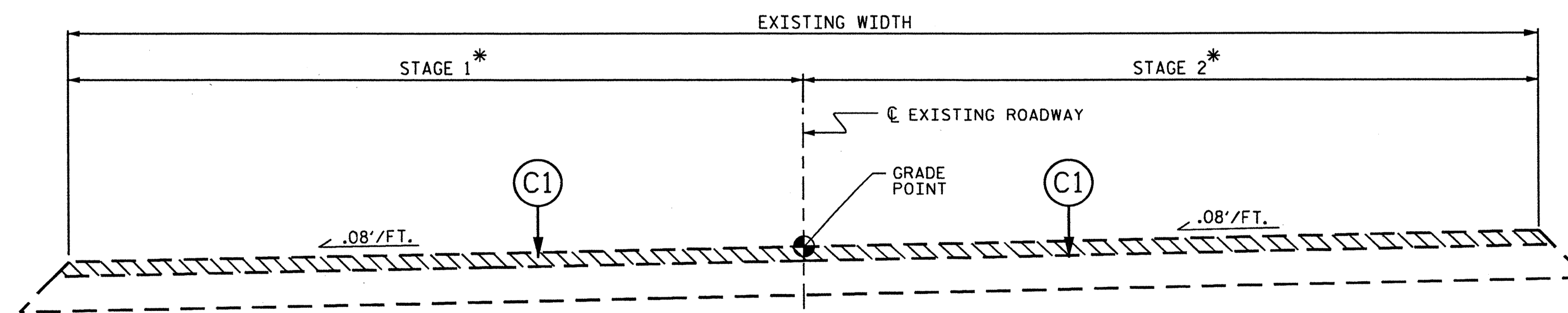

TYPICAL ROADWAY SECTION

PROJECT NO. 17BP.1.P.3
 COUNTY: BERTIE
 DECK REPAIR BRIDGE NO. 50
 SHEET 3 OF 7

STATE OF NORTH CAROLINA DEPARTMENT OF TRANSPORTATION RALEIGH						SHEET NO. S-27
TYPICAL ROADWAY SECTION AND MILLING DETAILS						TOTAL SHEETS 50
REVISIONS						NO.
NO.	BY:	DATE:	NO.	BY:	DATE:	
1			3			2
2			4			

DRAWN BY : K.H. COMPTON DATE : 9/11
 CHECKED BY : D. SNOKE DATE : 9/11

NOT TO SCALE

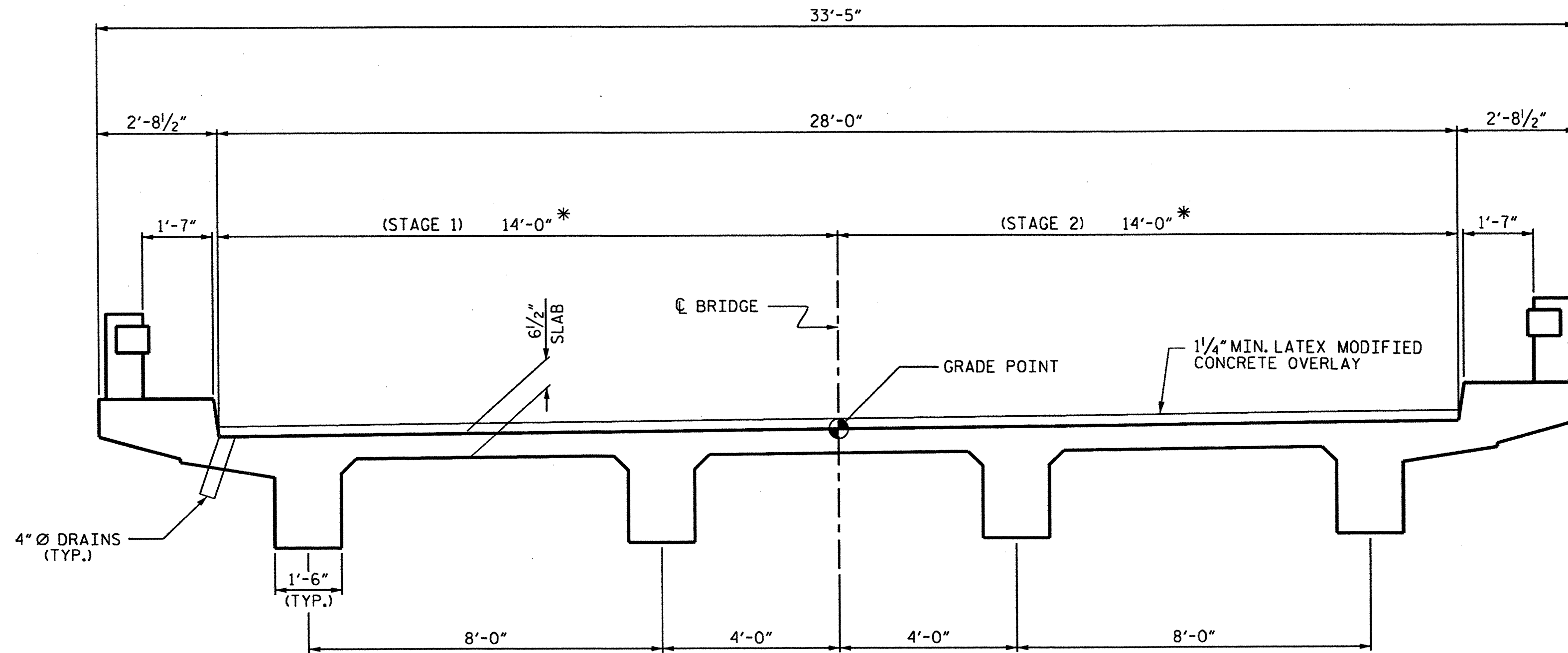

TYPICAL SECTION

* SEE STAGING PLAN IN TRAFFIC CONTROL PLAN, SHEET TMP-4

ELASTOMERIC CONCRETE	
BENTS	16.0 (CU. FT.)
END BENTS	0 (CU. FT.)
* TOTAL	16.0 (CU. FT.)

* BASED ON THE MINIMUM BLOCKOUT SHOWN.

NOTES

EXISTING DECK DRAINS SHALL BE SEALED PRIOR TO BEGINNING REPAIR OF BRIDGE DECKS WITH LATEX MODIFIED CONCRETE. SEE SPECIAL PROVISIONS.

FOR HYDRO-DEMOLITION, SEE SPECIAL PROVISIONS.

THE CONTRACTOR MUST COLLECT, TREAT AND DISPOSE OF RUN-OFF WATER FROM THE HYDRO-DEMOLITION PROCESS, SEE SPECIAL PROVISIONS.

THE BOUNDARIES OF AREAS IDENTIFIED FOR CLASS III SURFACE PREPARATION ARE APPROXIMATE. THE CONTRACTOR SHALL PROVIDE A METHOD OF HANDLING UNEXPECTED BLOW THROUGH OF DECK. SEE DETAIL.

FOR OVERLAY OF BRIDGE DECKS WITH LATEX MODIFIED CONCRETE, SEE SPECIAL PROVISIONS.

SEE SPECIAL PROVISIONS FOR SURFACE PREPARATION.

EXISTING BRIDGE INFORMATION BASED ON BEST AVAILABLE DATA.

FOR FOAM JOINT SEAL SEE SPECIAL PROVISIONS.

THE INSTALLED FOAM JOINT SEAL SHALL BE WATER TIGHT.

NOMINAL UNCOMPRESSED SEAL WIDTH OF FOAM JOINT SEAL SHALL BE 2 1/2" AT BENTS.

THE CONTRACTOR WILL NOT BE PERMITTED TO FORM THE JOINT FOR THE FOAM JOINT SEAL IN LIEU OF SAWING THE JOINT

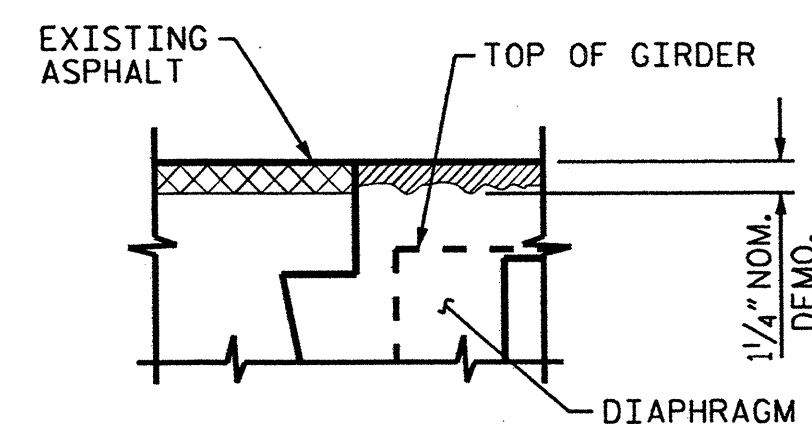

SECTION A-A
(EXISTING JOINT)

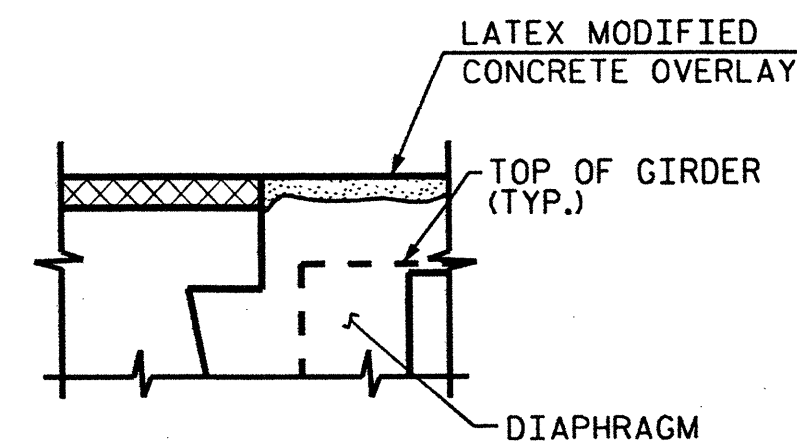

SECTION A-A
(PROPOSED JOINT)

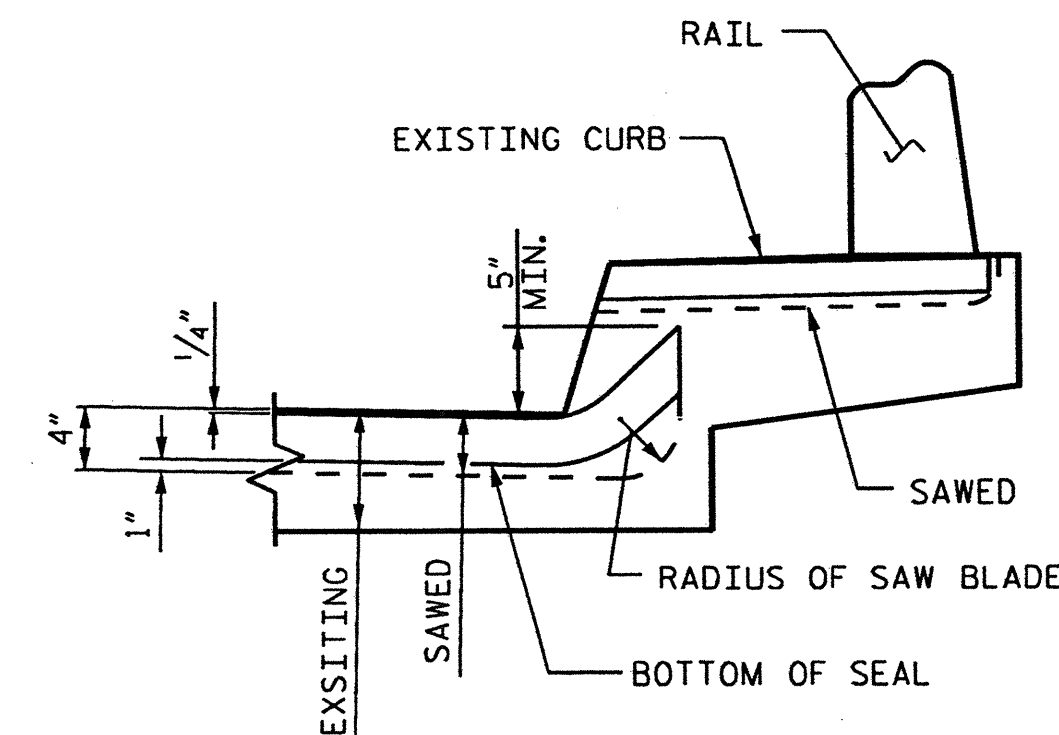

SECTION C-C

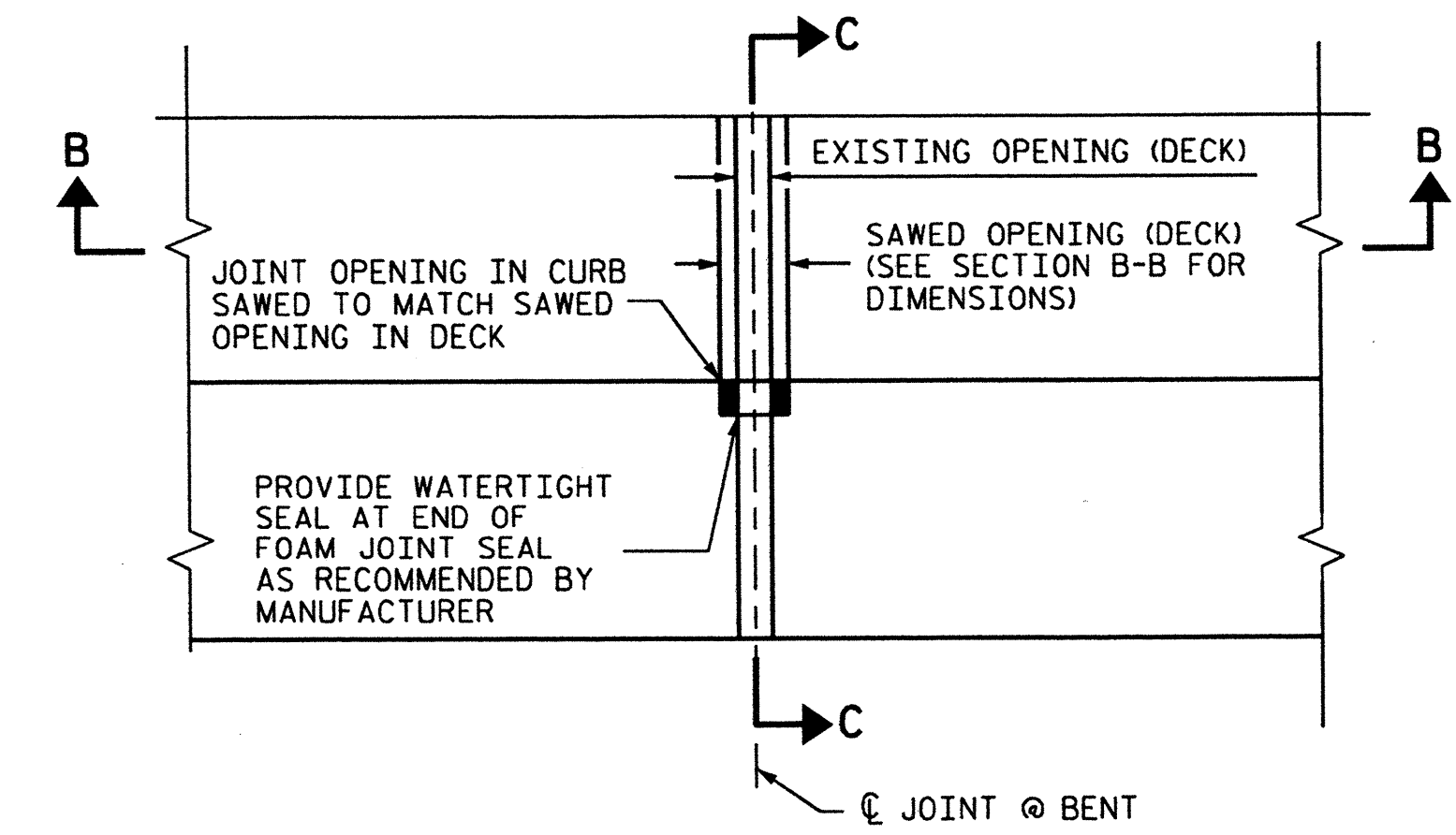

FOAM JOINT SEAL DETAILS

* SEAL WIDTH IN CURB TO BE DETERMINED BY THE ENGINEER

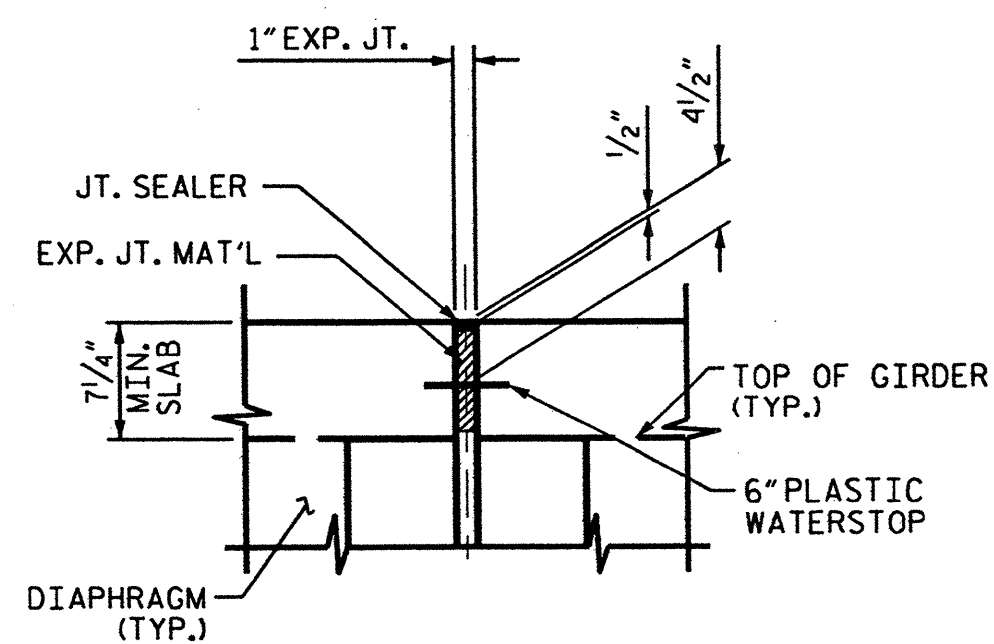

SECTION B-B
(EXISTING JOINT)

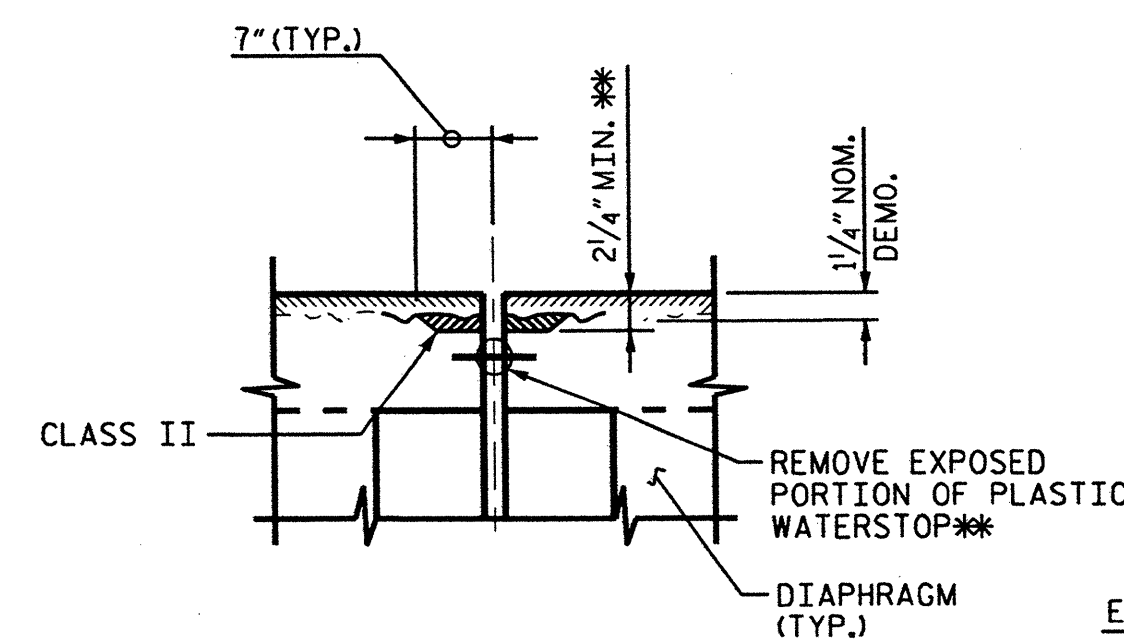

SECTION B-B
(MINIMUM EXISTING JOINT DEMOLITION)

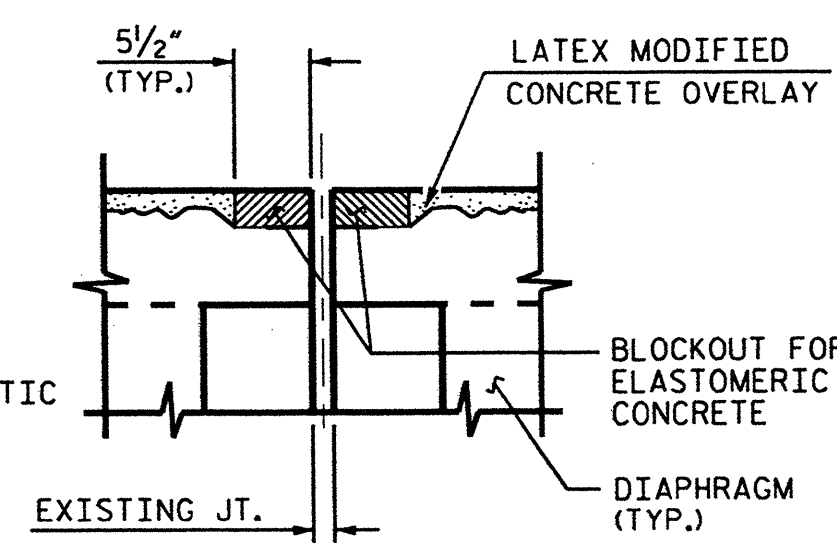

SECTION B-B
(PROPOSED EVAZOTE JOINT SEAL PRE-SAWED DIMENSIONS)

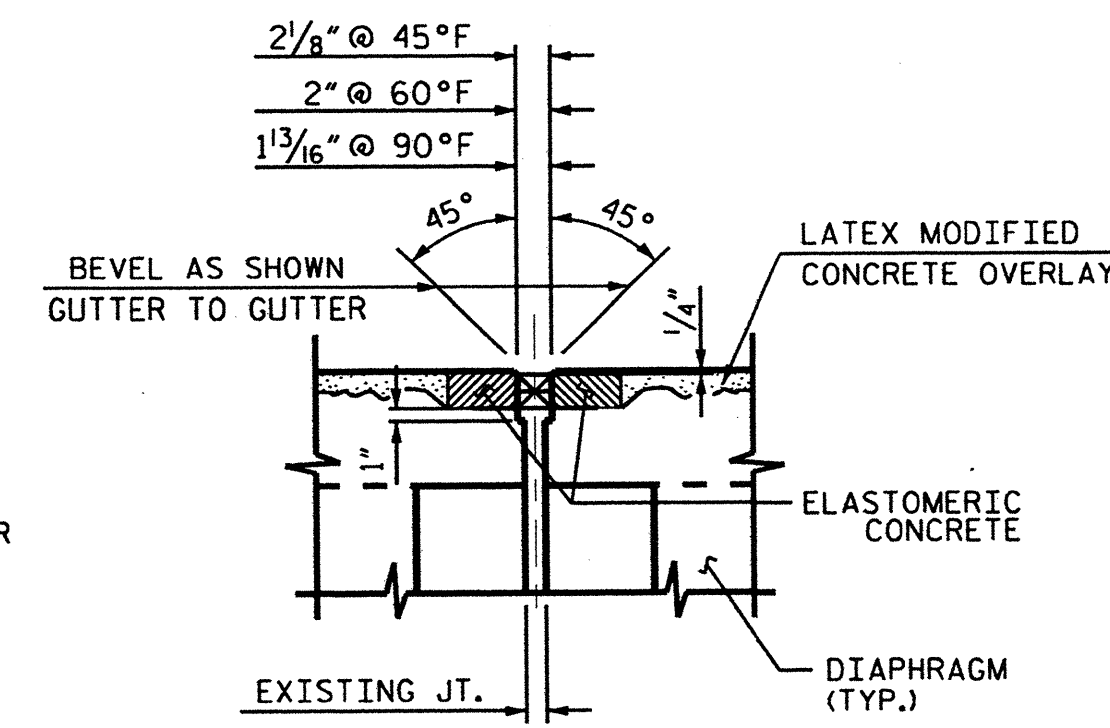

SECTION B-B
(PROPOSED EVAZOTE JOINT SEAL EXPANSION)

** ALL LOOSE AND UNSOUND CONCRETE SHALL BE REMOVED. IF THE EMBEDDED PORTION OF THE EXISTING PLASTIC WATERSTOP IS EXPOSED DURING REMOVAL OF UNSOUND CONCRETE, THE ENTIRE WATERSTOP SHALL BE REMOVED.

PROJECT NO. 17BP.1.P.3

COUNTY: BERTIE

DECK REPAIR BRIDGE NO. 50

SHEET 4 OF 7

STATE OF NORTH CAROLINA
DEPARTMENT OF TRANSPORTATION
RALEIGH

TYPICAL SECTION AND JOINT DETAILS

REVISIONS						SHEET NO.
NO.	BY:	DATE:	NO.	BY:	DATE:	S-28
1			3			TOTAL SHEETS
2			4			50

DRAWN BY : K.H. COMPTON DATE : 9/11
CHECKED BY : D. SNOKE DATE : 9/11

NOTES

1. FOR EXAMPLES OF TYPICAL ENCAPSULATION OF PILES SEE SHEETS #30 AND #31.
2. REPAIR OF THE BRIDGE SHALL BE PERFORMED SO AS NOT TO ALLOW DEBRIS TO FALL INTO THE WATER.

PILE ENCAPSULATION LOCATIONS

BENT	PILE	LF
1	ALL	31.7
2	ALL	31.7
3	ALL	19.4
TOTAL	15	83

PILE ENCAPSULATION LENGTHS INCLUDE 1'-0" ABOVE DAMAGED AREA AND 1'-0" BELOW MUD LINE.

QUANTITIES ARE BASED ON BEST AVAILABLE INFORMATION.

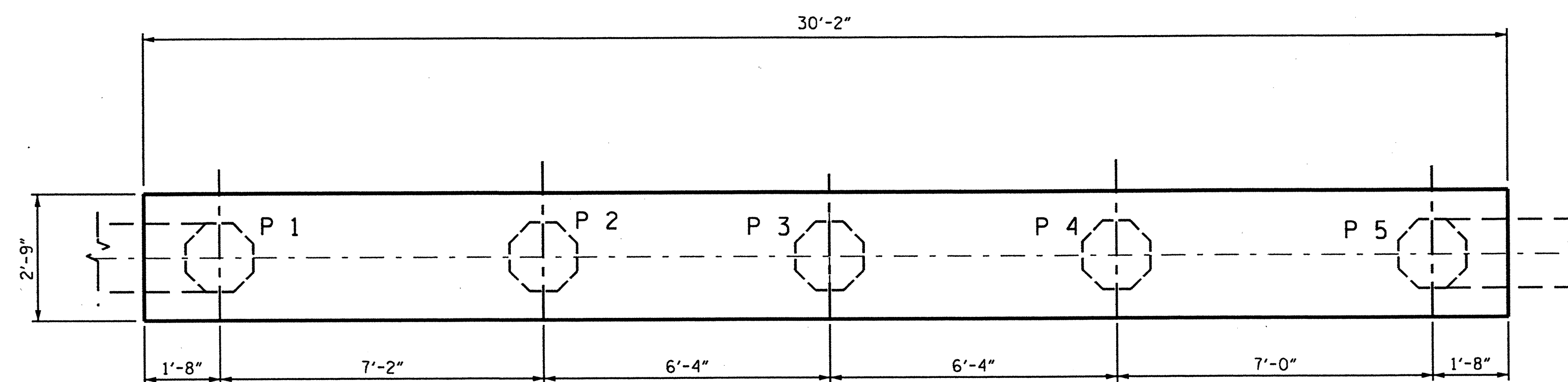

PLAN OF BENT No. 1
(BENT No. 2 & 3 SIMILAR)

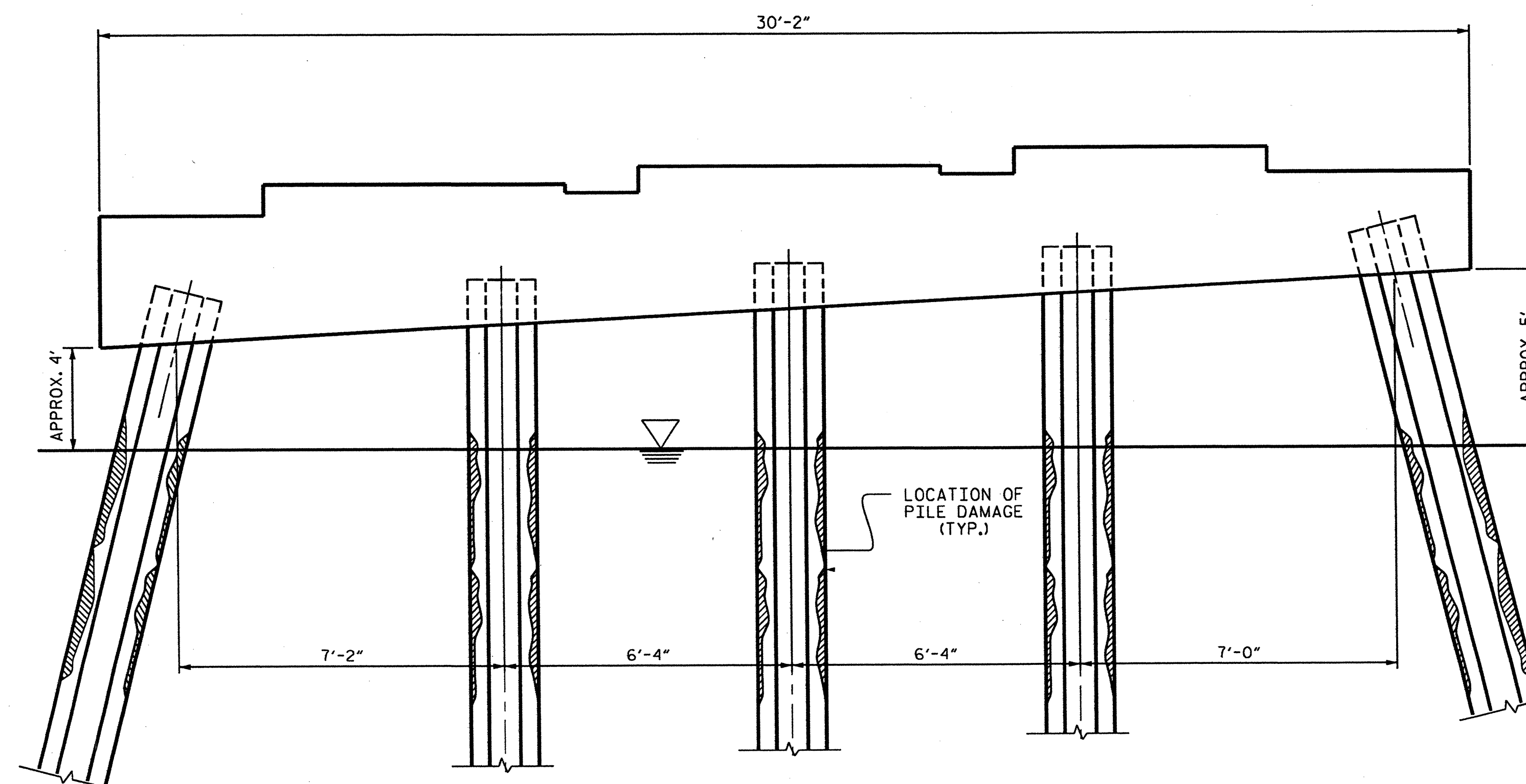

ELEVATION VIEW BENT No. 1
(BENT No. 2 & 3 SIMILAR)

PROJECT NO. 17BP.1.P.3
 COUNTY: BERTIE
 DECK REPAIR BRIDGE NO. 50
SHEET 5 OF 7

STATE OF NORTH CAROLINA
 DEPARTMENT OF TRANSPORTATION
RALEIGH

PILE REPAIRS

BENTS #1, 2* AND #3

REVISIONS						SHEET NO.
NO.	BY:	DATE:	NO.	BY:	DATE:	S-29
1			3			TOTAL SHEETS
2			4			50

DRAWN BY : K.H. COMPTON DATE : 10/11
 CHECKED BY : D. SNOKE DATE : 10/11

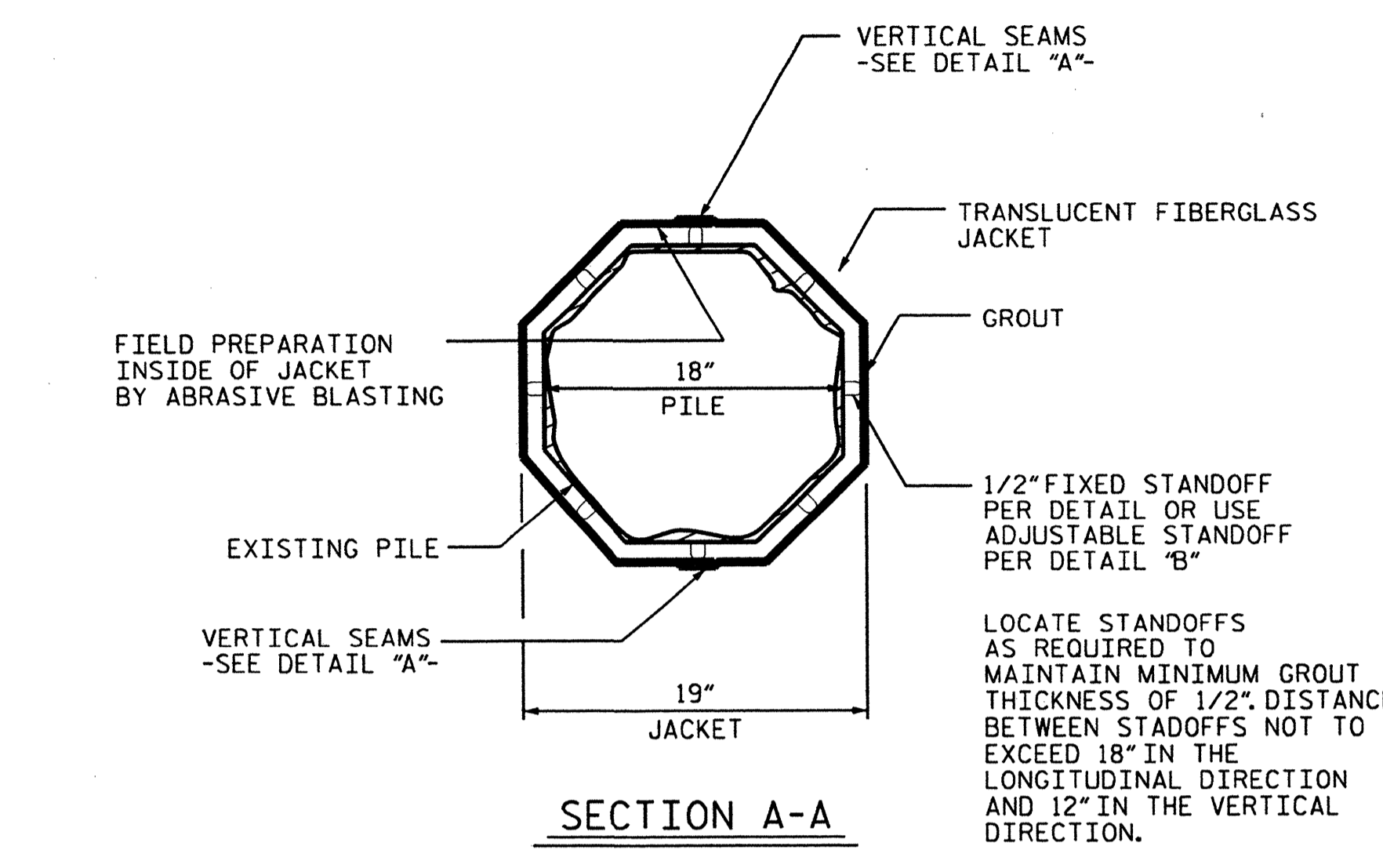
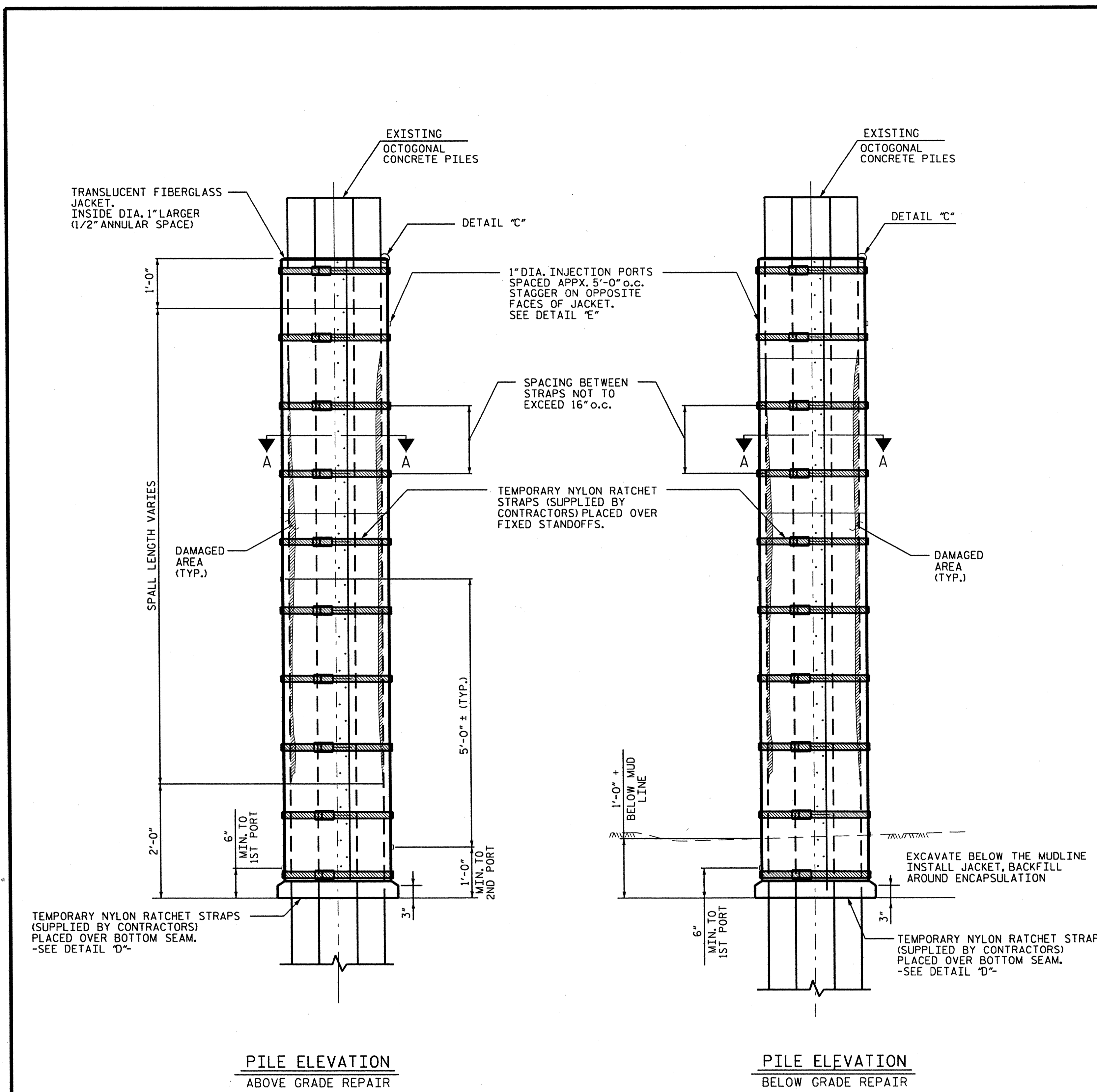

- ### REPAIR SEQUENCES
1. AFTER SURFACE PREPARATION, PLACE JACKET IN PROPER LOCATION AROUND PILE AND SEAL LONGITUDINAL SEAMS (SEE DETAIL "A"). INSTALL TEMPORARY BRACING.
 2. CONFIRM SPACING BETWEEN JACKET AND PILE. INSTALL BOTTOM SEAL (SEE DETAIL "D"). ALLOW BOTTOM SEAL TO CURE APPX. 4 HOURS.
 3. ATTACH GROUT HOSE TO LOWERMOST INJECTION PORT AND PUMP EPOXY GROUT FOR 30-sec. CHECK FOR LEAKS ALONG SEAMS AND BOTTOM SEAL. (OPTIONALLY ALLOW THIS GROUT TO CURE AND PROCEED WITH GROUT INJECTION FROM 2ND PORT.)
 4. PLUG UPPER INJECTION PORTS AND PUMP GROUT INTO LOWER PORT UNTIL GROUT REACHES TOP OF JACKET. ONLY USE UPPER PORTS IF INJECTION BECOMES DIFFICULT.

PROJECT NO. 17BP.1.P.3
 COUNTY: BERTIE
 DECK REPAIR BRIDGE NO. 50
 SHEET 6 OF 7

STATE OF NORTH CAROLINA DEPARTMENT OF TRANSPORTATION RALEIGH						SHEET NO. S-30
OCTOGANAL PILE ENCAPSULATION						TOTAL SHEETS 50
REVISIONS						
NO.	BY:	DATE:	NO.	BY:	DATE:	
1			3			
2			4			

DRAWN BY : K.H. COMPTON DATE : 10/11
 CHECKED BY : D. SNOKE DATE : 10/11

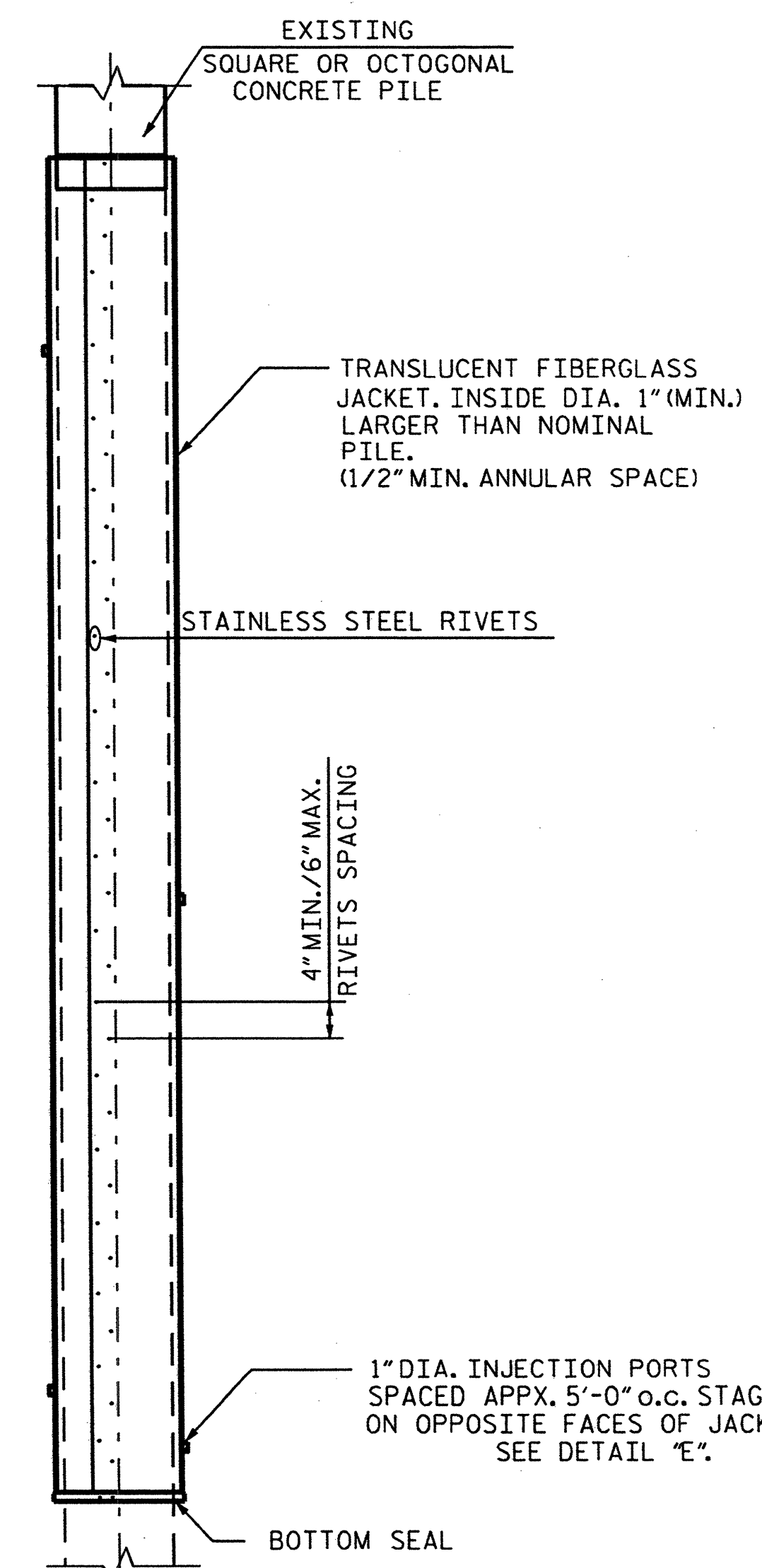

JACKET

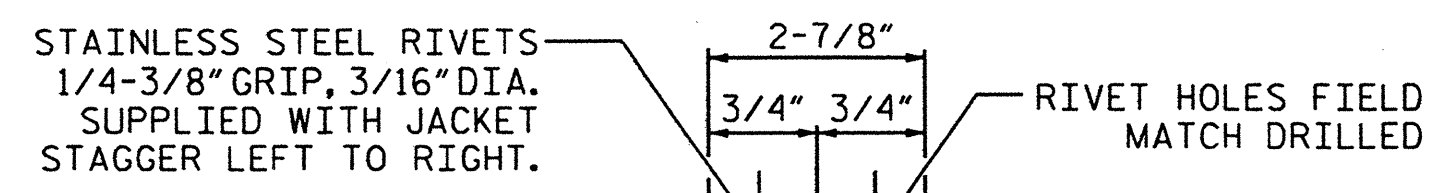

DETAIL A
SEAM DETAIL

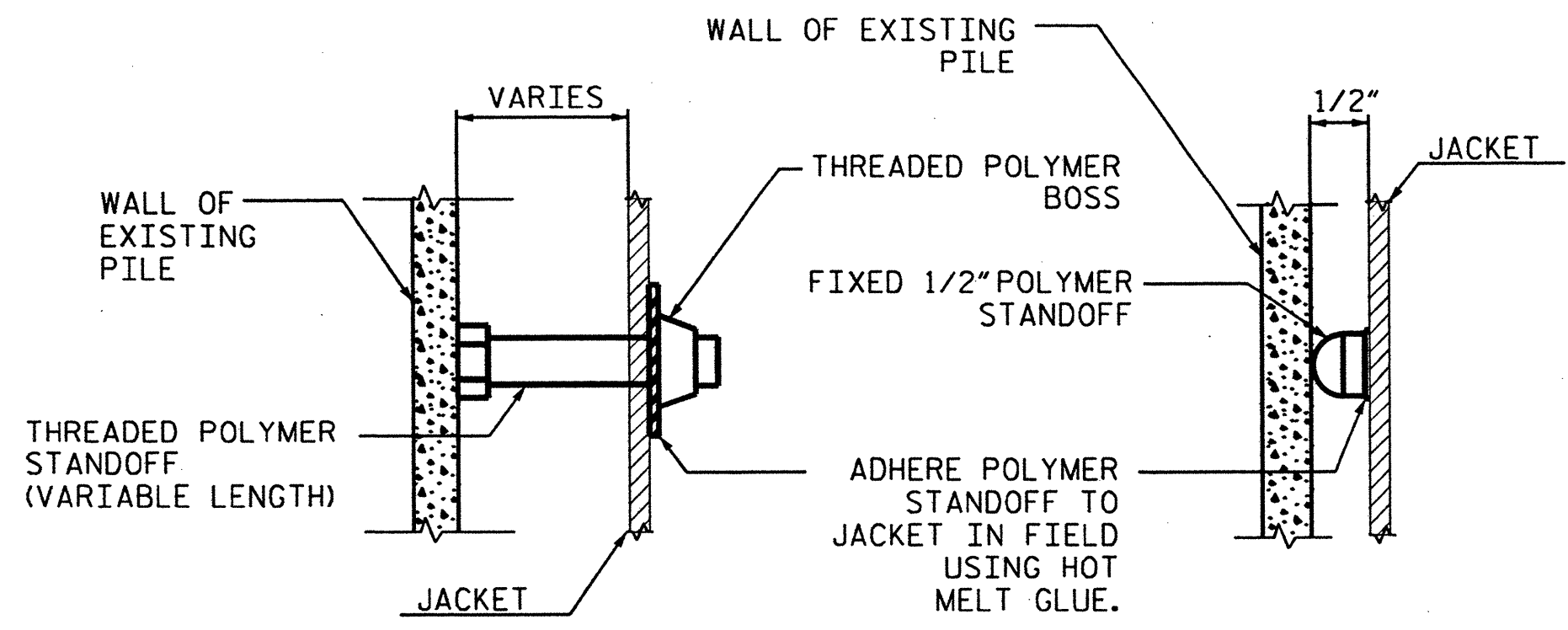

ADJUSTABLE STANDOFF DETAIL

FIXED STANDOFF DETAIL

DETAIL B

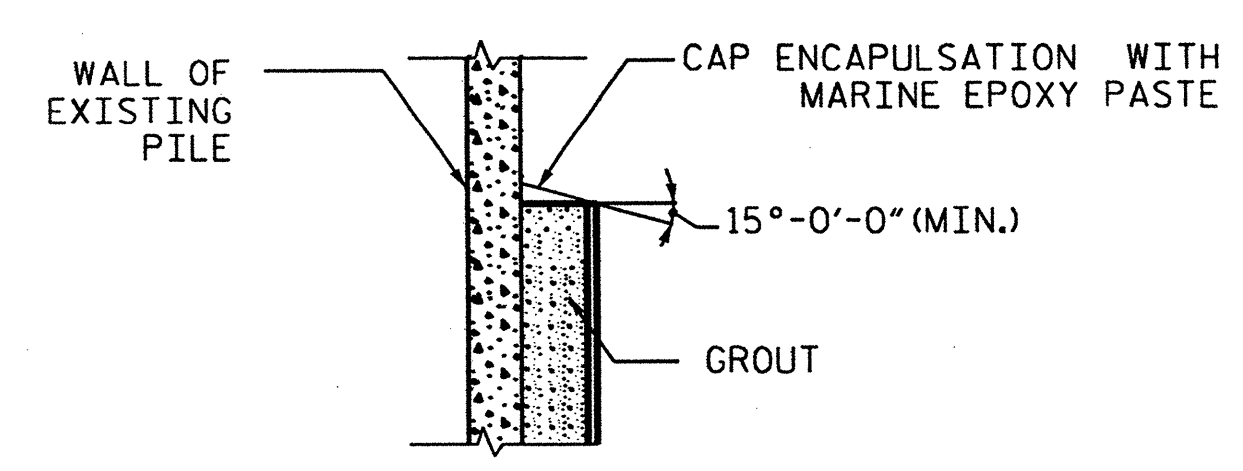

DETAIL C
-TOP OF JACKET-

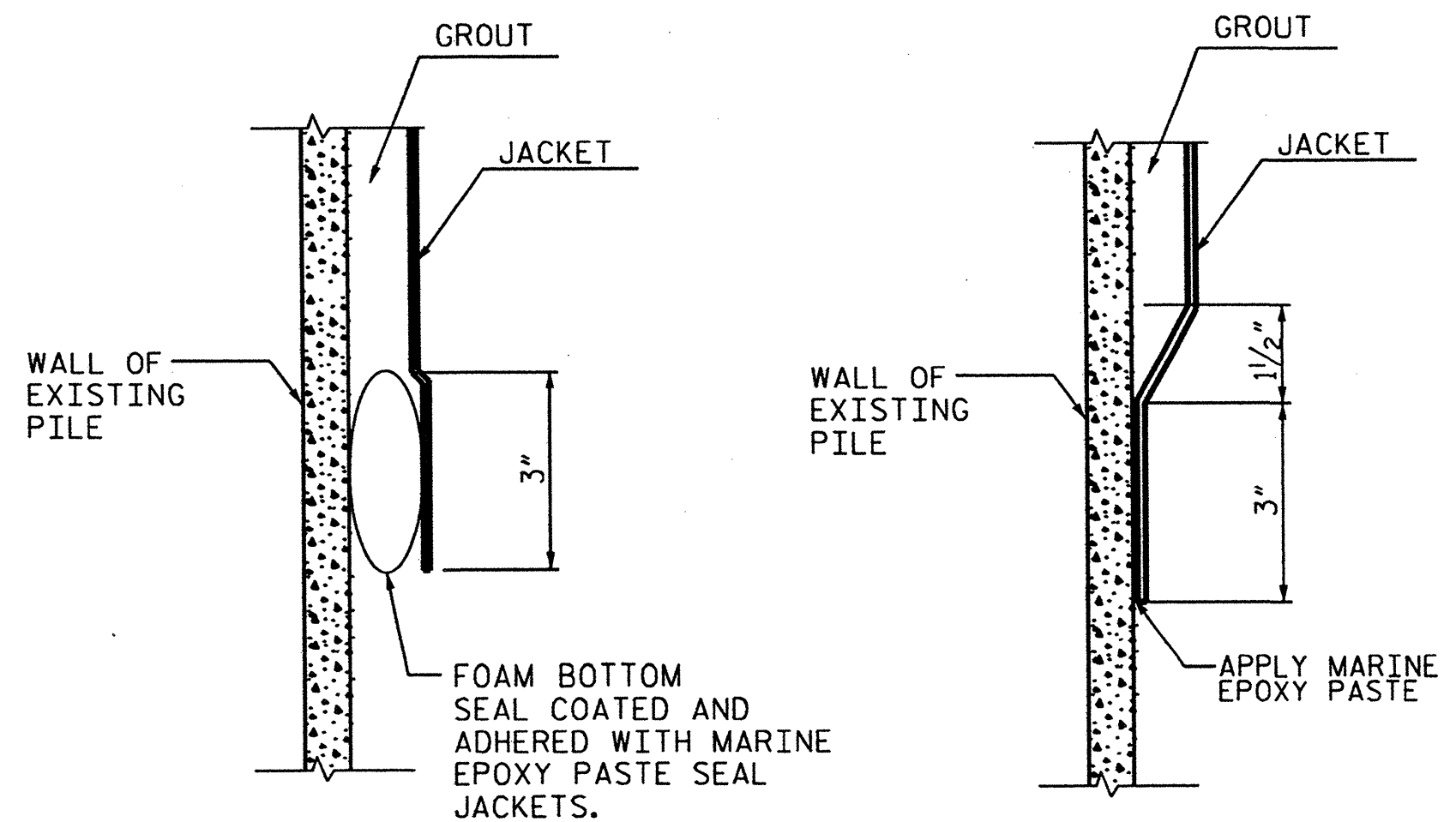

BOTTOM SEAL DETAIL

ALT. BOTTOM SEAL DETAIL

DETAIL D

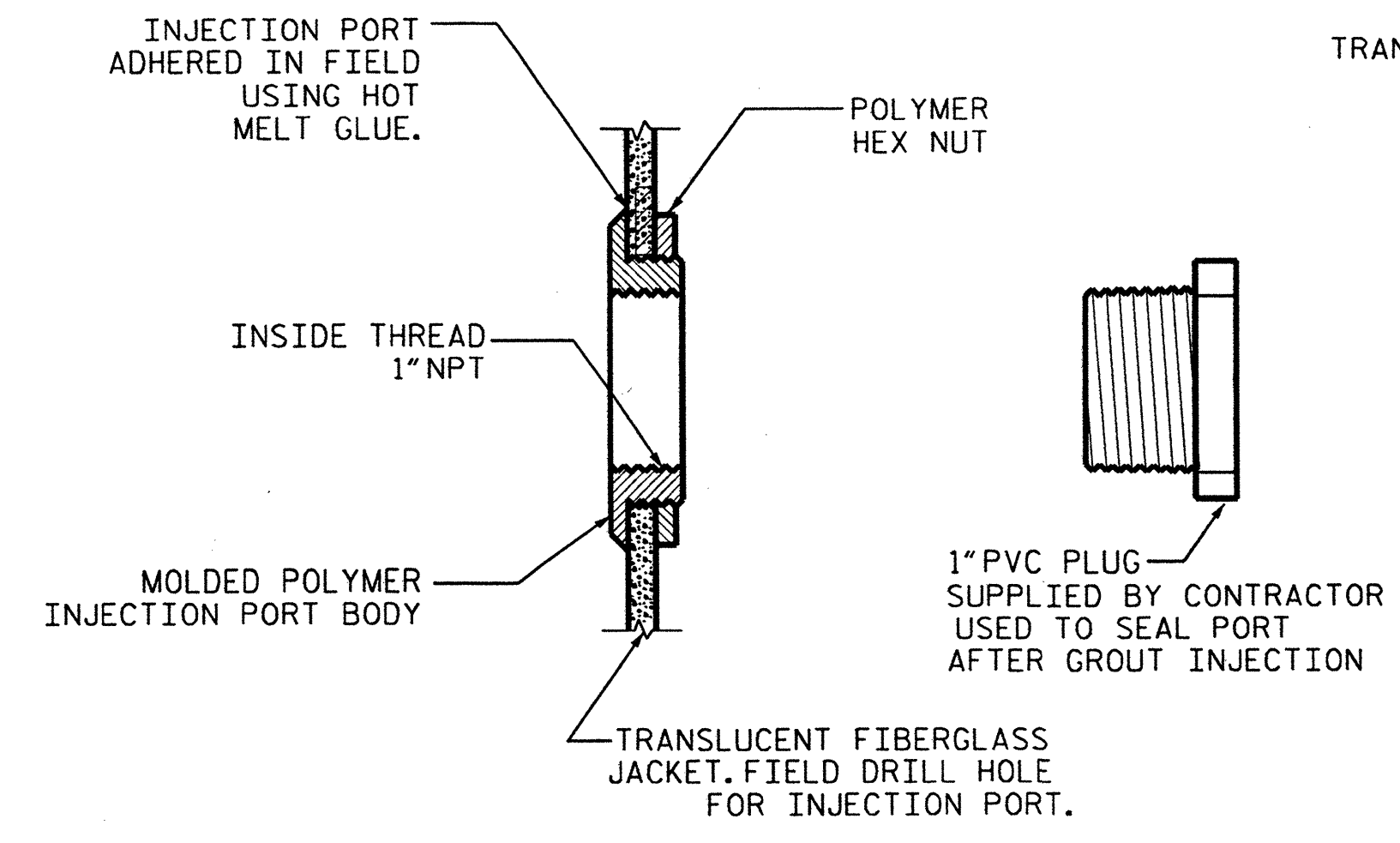

SECTION THRU PORT

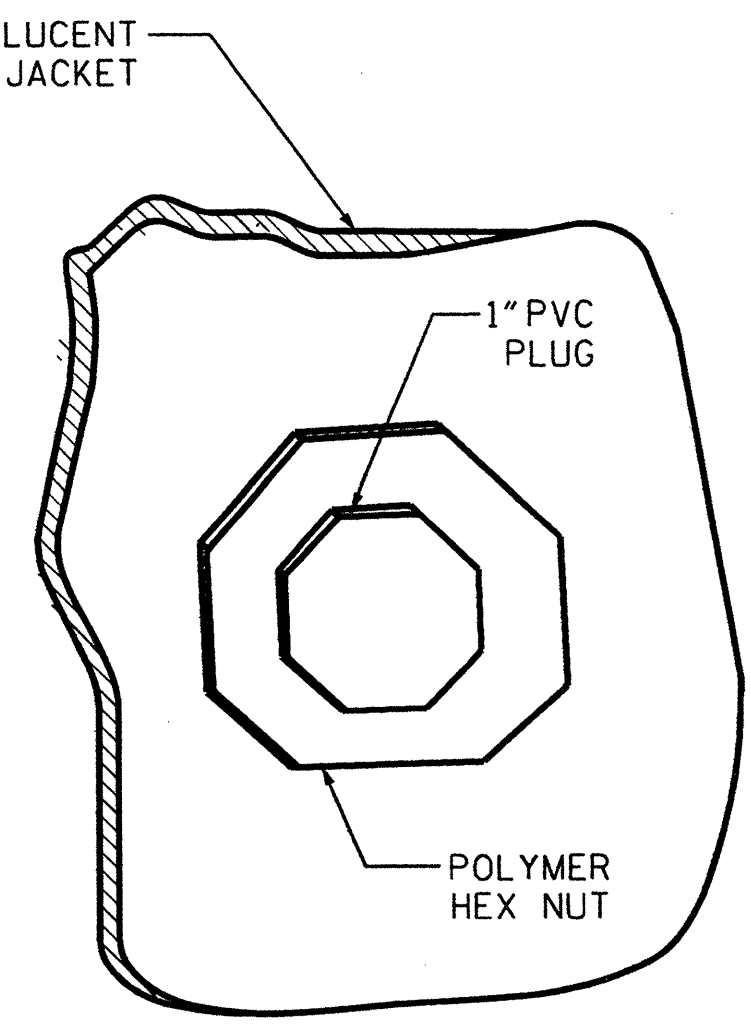

ISOMETRIC VIEW

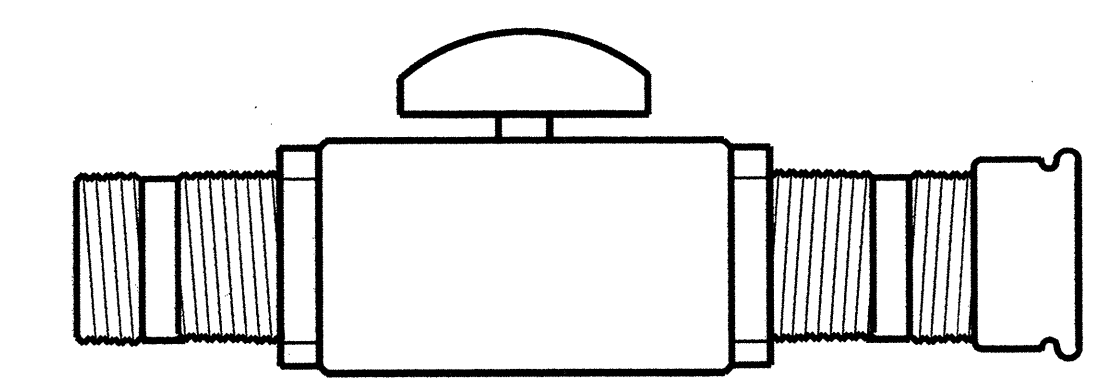

TEMPORARY GROUT FITTING SUPPLIED BY CONTRACTORS TO BE PVC BALL VALVE AND CAM LOCK TO FIT 1\"/>

DETAIL E

PROJECT NO. 17BP.1.P.3
 COUNTY: BERTIE
 DECK REPAIR BRIDGE NO. 50
 SHEET 7 OF 7

STATE OF NORTH CAROLINA DEPARTMENT OF TRANSPORTATION RALEIGH						SHEET NO. S-31
PILE ENCAPSULATION DETAILS						TOTAL SHEETS 50
REVISIONS						
NO.	BY:	DATE:	NO.	BY:	DATE:	
1			3			
2			4			

DRAWN BY : K.H. COMPTON DATE : 10/11
 CHECKED BY : D. SNOKE DATE : 10/11

← WILLIAMSTON

JAMESVILLE →

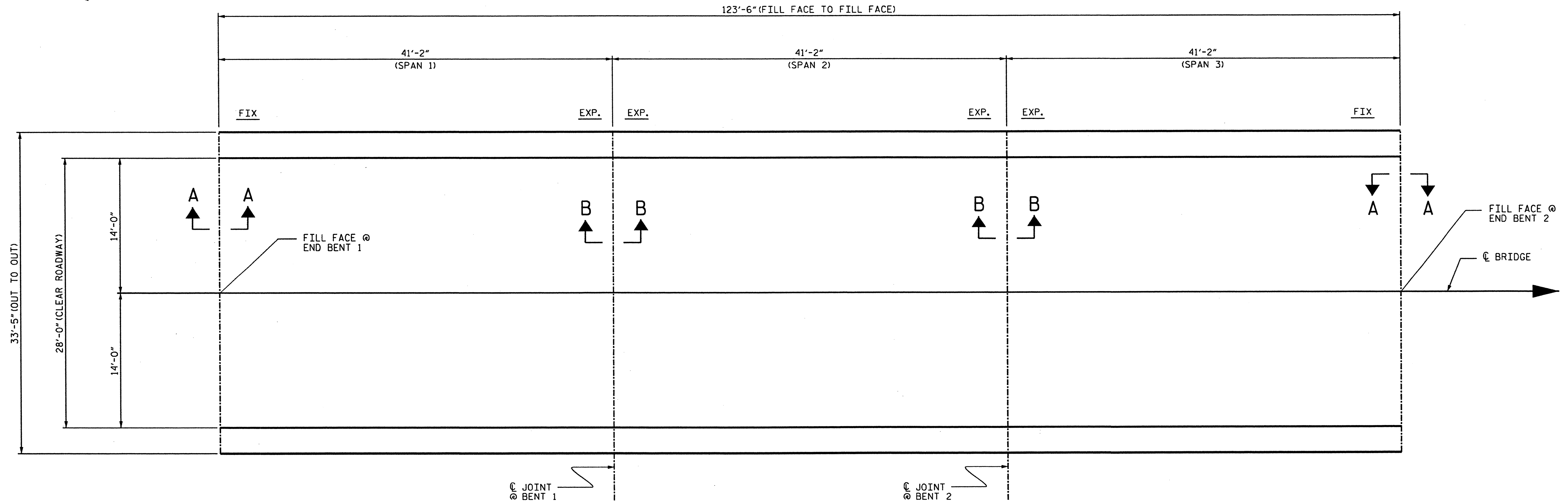

FINISHED SURFACE OF LATEX MODIFIED OVERLAY AND SURFACE OF ORIGINAL DECK BEFORE WORK BEGINS.

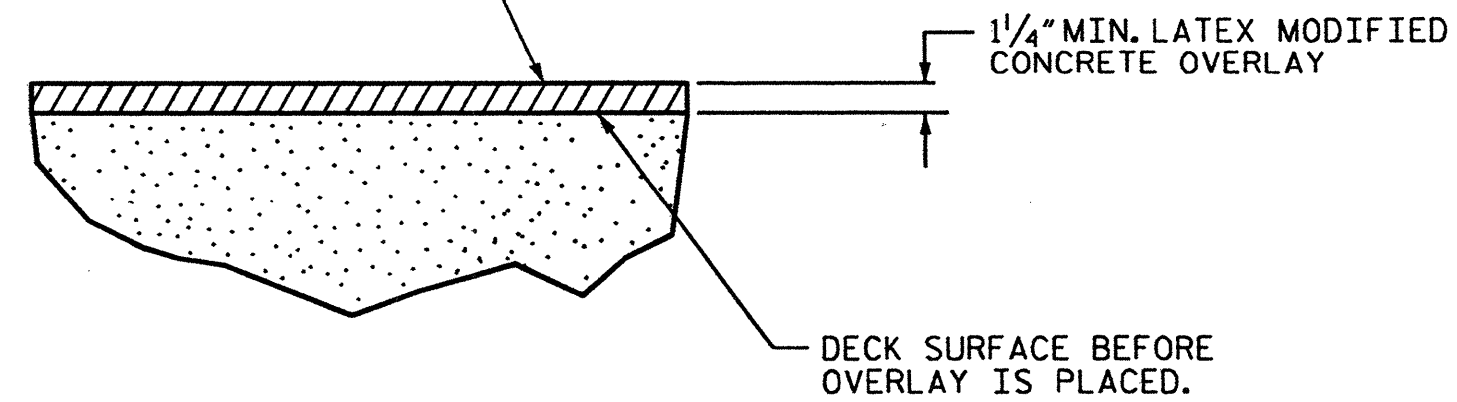

DETAIL FOR LATEX MODIFIED CONCRETE OVERLAY

PLAN OF SPANS- DECK REPAIRS

ENTIRE DECK TO BE SCARIFIED AND HYDRODEMOLITION

- APPROX. AREA: CLASS II REPAIR
- APPROX. AREA: CLASS III REPAIR

TOTAL BILL OF MATERIAL

DECK ** SCARIFICATION	CLASS I * SURFACE PREPARATION	CLASS II * SURFACE PREPARATION	CLASS III * SURFACE PREPARATION	HYDRO- DEMOLITION OF BRIDGE DECK	LATEX MODIFIED CONCRETE	PLACING & FINISHING LATEX MODIFIED CONCRETE	FOAM JOINT SEALS	GROOVING BRIDGE FLOORS	ASPHALT CONC. SURF. COURSE TYPE S9.5B
SO.YDS.	SO.YDS.	SO.YDS.	SO.YDS.	SO.YDS.	C.Y.	SO.YDS.	LUMP SUM	SO. FT.	TON
1,940	0	0	0	384	16.0	384	LUMP SUM	2,988	84

* QUANTITIES ARE SHOWN FOR INFORMATIONAL PURPOSES ONLY. IF ANY CLASS III LOCATIONS ARE ENCOUNTERED PRIOR TO OR DURING HYDRO-DEMOLITION, SEE TYP. "BLOW THRU" CONTAINMENT AND FALSEWORK DETAILS.

** INCLUDES MILLING OF ROADWAY PAVEMENT.

DRAWN BY : K.H. COMPTON DATE : 9/11
 CHECKED BY : D. SNOKE DATE : 9/11

10-NOV-2011 10:09
 Z:\Squid\Deck\Division 1\Proj01.dns\DKREHAB_570007.dgn
 dmuller

PROJECT NO. 17BP.1.P.3

COUNTY: MARTIN

DECK REPAIR BRIDGE NO: 7

SHEET 1 OF 3

STATE OF NORTH CAROLINA
 DEPARTMENT OF TRANSPORTATION
 RALEIGH

**PLAN OF BRIDGE
 AND
 BILL OF MATERIALS**

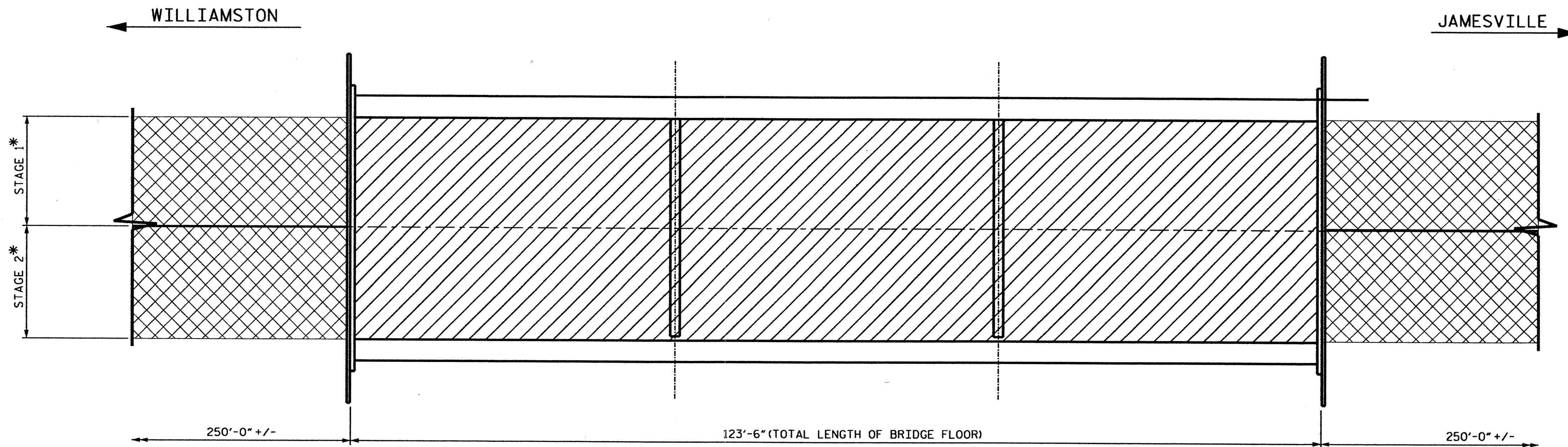

28'-0" CLEAR ROADWAY (90°-00' SKEW)

REVISIONS						SHEET NO.
NO.	BY:	DATE:	NO.	BY:	DATE:	S-32
1			3			TOTAL SHEETS
2			4			50



* SEE STAGING PLAN IN TRAFFIC CONTROL PLAN, SHEETS TMP-5 & TMP-6

PLAN

-  DECK SCARIFICATION AND HYDRODEMOLITION
-  MILLING OF ROADWAY APPROACH

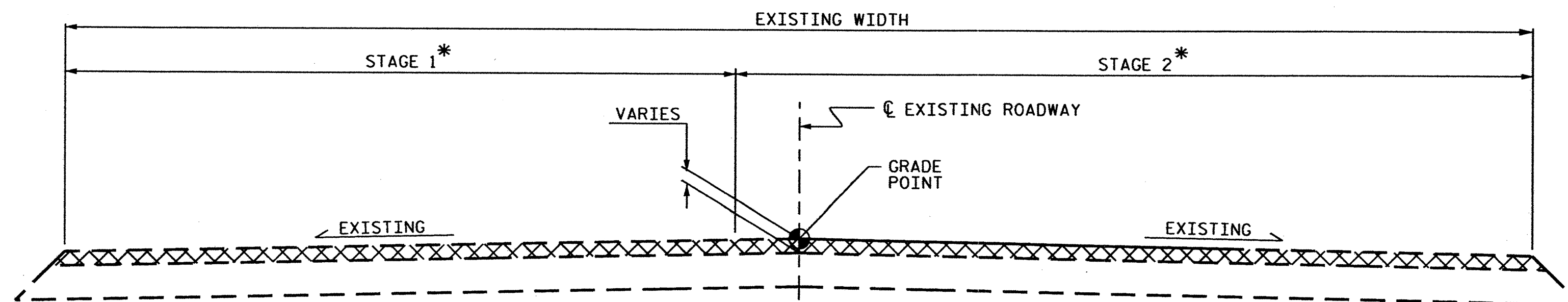

TYPICAL ROADWAY MILLING SECTION

C1 PROPOSED VARIABLE DEPTH ASPHALT CONCRETE SURFACE COURSE, TYPE SF 9.5B AT AN AVERAGE RATE OF 110 LBS. PER SQ. YD. PER 1" DEPTH. TO BE PLACED IN LAYERS NOT LESS THAN 1" IN DEPTH OR GREATER THAN 1 1/2" IN DEPTH.

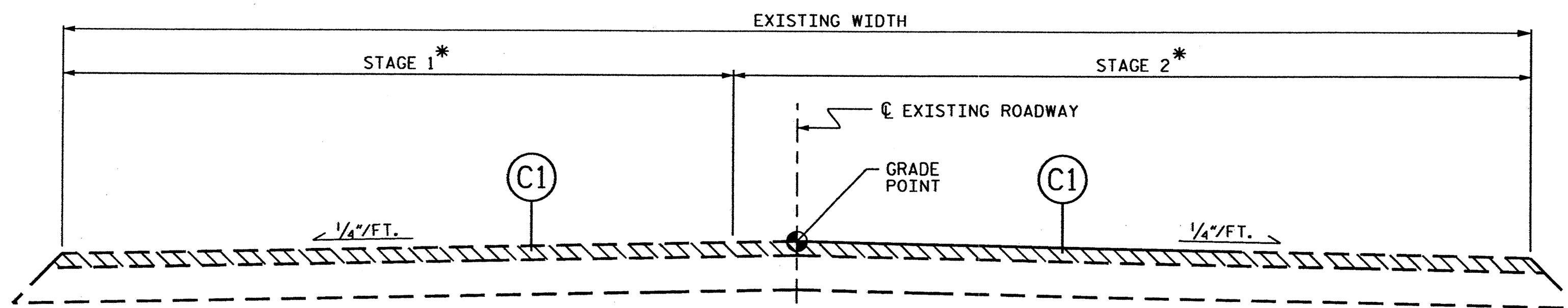

TYPICAL ROADWAY SECTION

PROJECT NO. 17BP.1.P.3
 COUNTY: MARTIN
 DECK REPAIR BRIDGE NO. 7
 SHEET 2 OF 3

STATE OF NORTH CAROLINA
 DEPARTMENT OF TRANSPORTATION
 RALEIGH
 TYPICAL ROADWAY
 SECTION AND
 MILLING DETAILS

DRAWN BY : K.H. COMPTON DATE : 9/11
 CHECKED BY : D. SNOKE DATE : 9/11

NOT TO SCALE

REVISIONS						SHEET NO.
NO.	BY:	DATE:	NO.	BY:	DATE:	S-33
1	DNS	2/12	3			TOTAL SHEETS
2			4			50

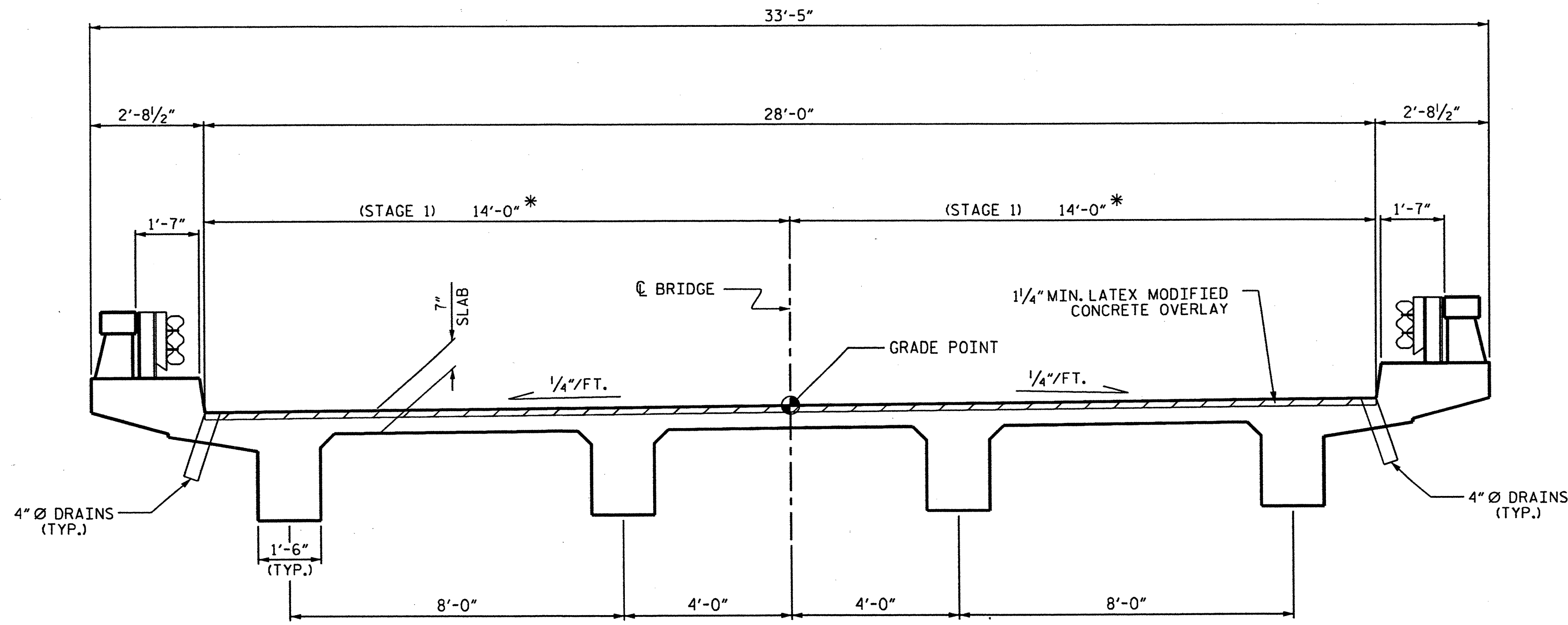

TYPICAL SECTION

* SEE STAGING PLAN IN TRAFFIC CONTROL PLAN, SHEETS TMP-5 & TMP-6

ELASTOMERIC CONCRETE	
BENTS	10.7 (CU. FT.)
END BENTS	0 (CU. FT.)
* TOTAL	10.7 (CU. FT.)

* BASED ON THE MINIMUM BLOCKOUT SHOWN.

NOTES

- EXISTING DECK DRAINS SHALL BE SEALED PRIOR TO BEGINNING REPAIR OF BRIDGE DECKS WITH LATEX MODIFIED CONCRETE. SEE SPECIAL PROVISIONS.
- FOR HYDRO-DEMOLITION, SEE SPECIAL PROVISIONS.
- THE CONTRACTOR MUST COLLECT, TREAT AND DISPOSE OF RUN-OFF WATER FROM THE HYDRO-DEMOLITION PROCESS, SEE SPECIAL PROVISIONS.
- THE BOUNDARIES OF AREAS IDENTIFIED FOR CLASS III SURFACE PREPARATION ARE APPROXIMATE. THE CONTRACTOR SHALL PROVIDE A METHOD OF HANDLING UNEXPECTED BLOW THROUGH OF DECK. SEE DETAIL.
- FOR OVERLAY OF BRIDGE DECKS WITH LATEX MODIFIED CONCRETE, SEE SPECIAL PROVISIONS.
- SEE SPECIAL PROVISIONS FOR SURFACE PREPARATION.
- EXISTING BRIDGE INFORMATION BASED ON BEST AVAILABLE DATA.
- FOR FOAM JOINT SEAL SEE SPECIAL PROVISIONS.
- THE INSTALLED FOAM JOINT SEAL SHALL BE WATER TIGHT.
- NOMINAL UNCOMPRESSED SEAL WIDTH OF FOAM JOINT SEAL SHALL BE 2 1/2" AT BENTS.
- THE CONTRACTOR WILL NOT BE PERMITTED TO FORM THE JOINT FOR THE FOAM JOINT SEAL IN LIEU OF SAWING THE JOINT

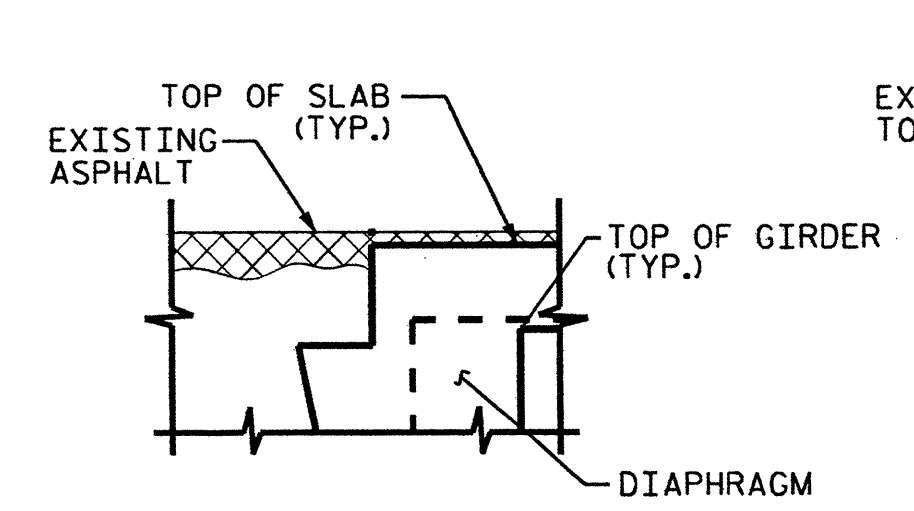

SECTION A-A
(EXISTING JOINT)

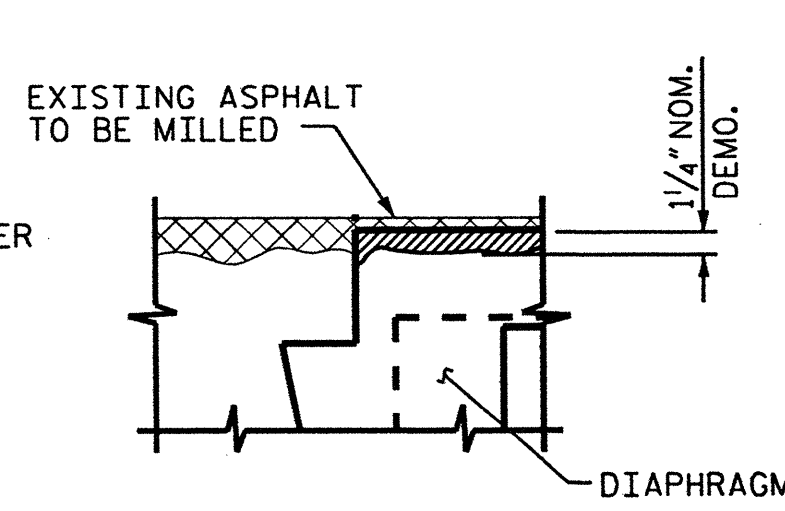

SECTION A-A
(MINIMUM EXISTING JOINT DEMOLITION)

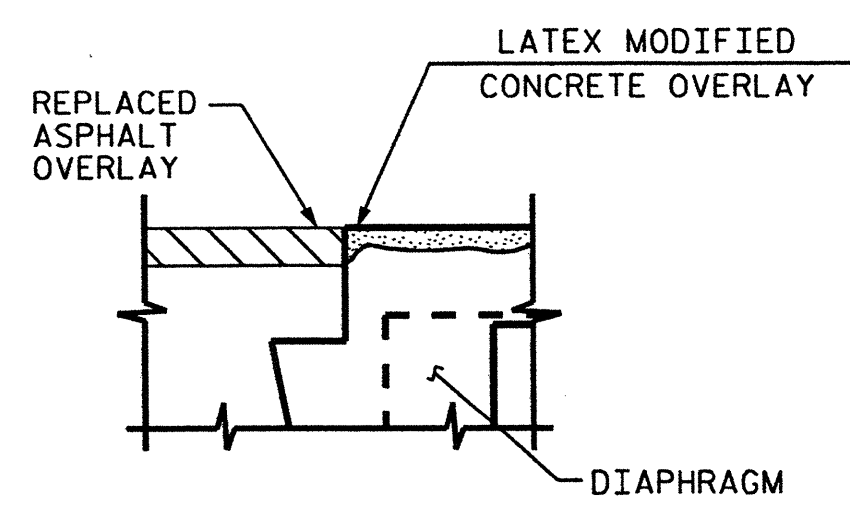

SECTION A-A
(PROPOSED JOINT)

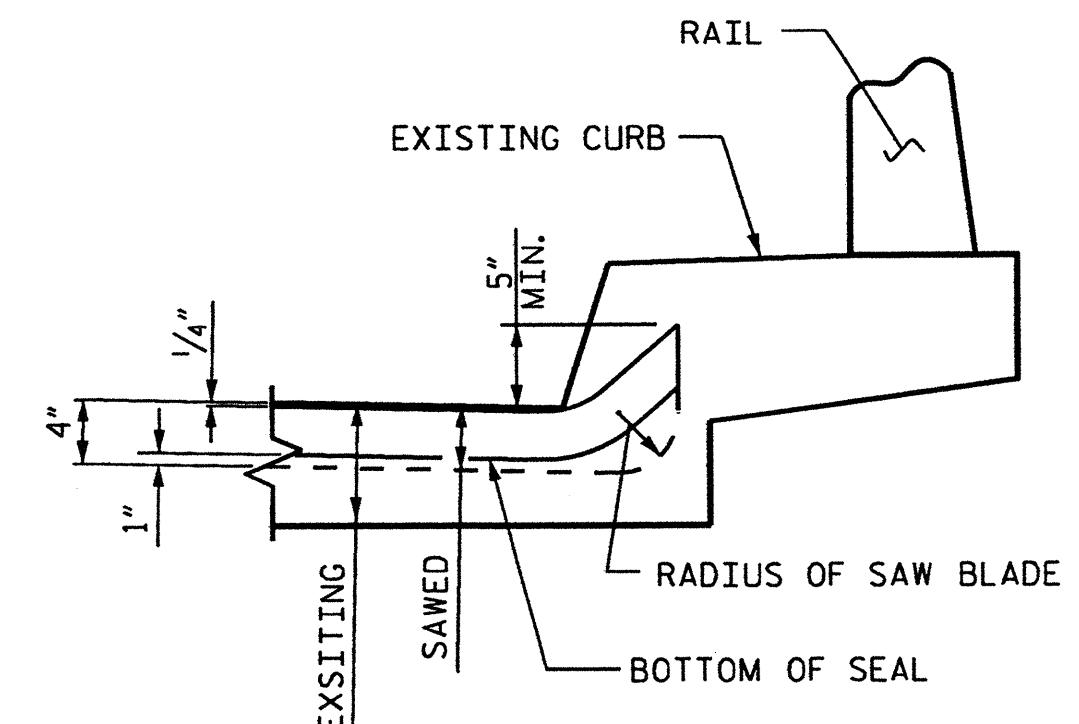

SECTION C-C

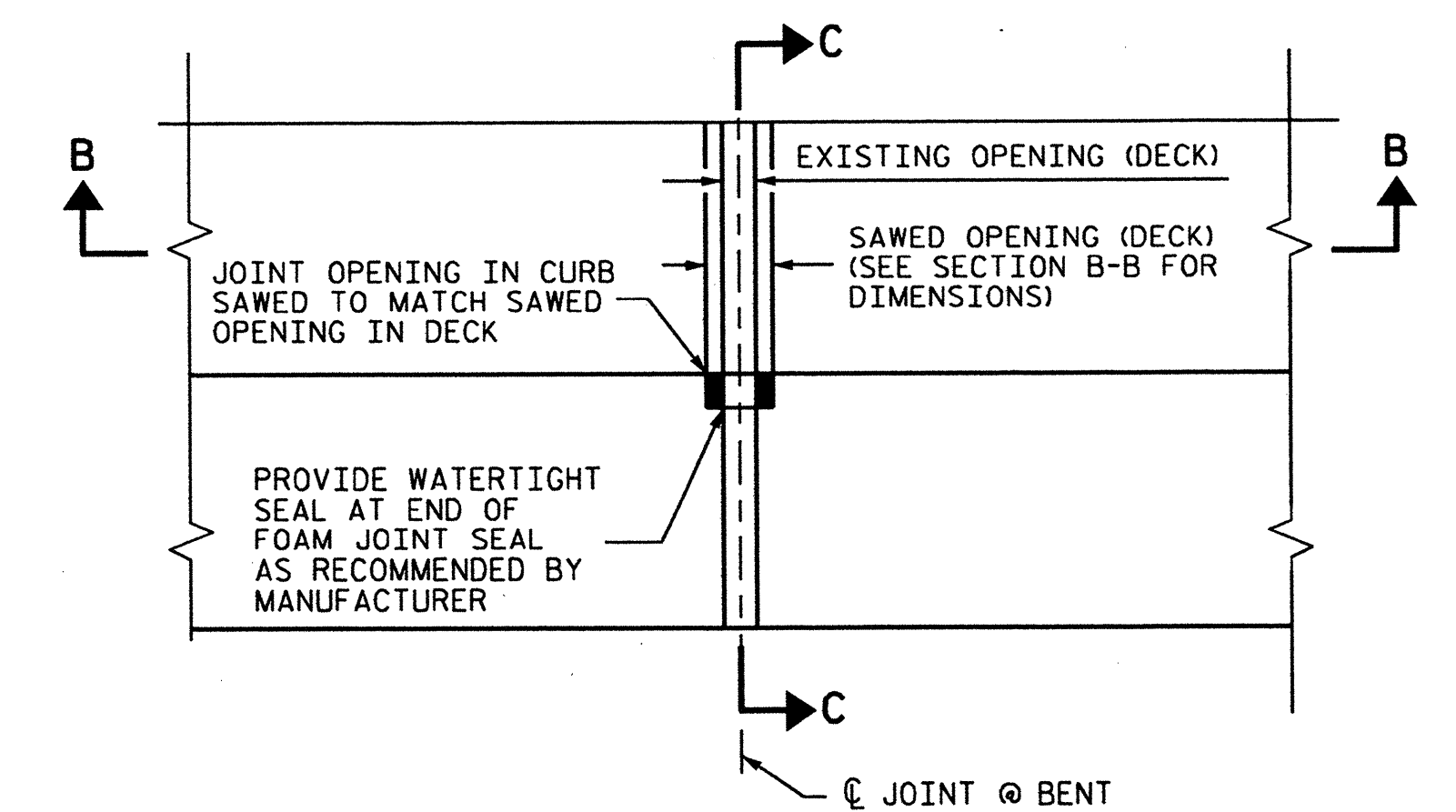

FOAM JOINT SEAL DETAILS
(FOR INT. BENT JOINTS ONLY)

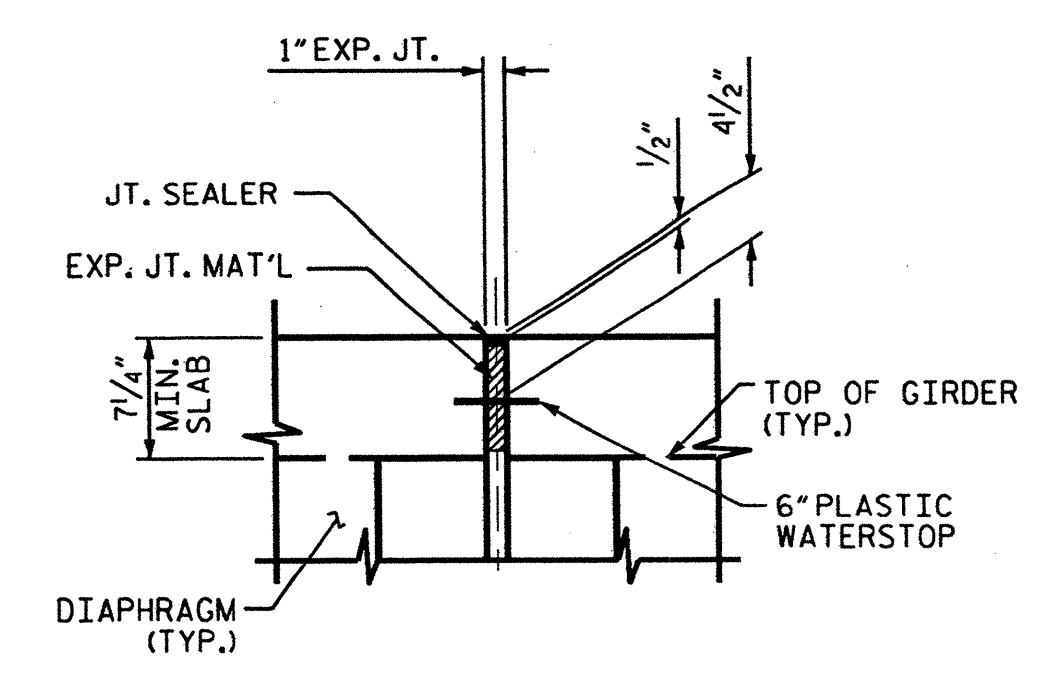

SECTION B-B
(EXISTING JOINT)

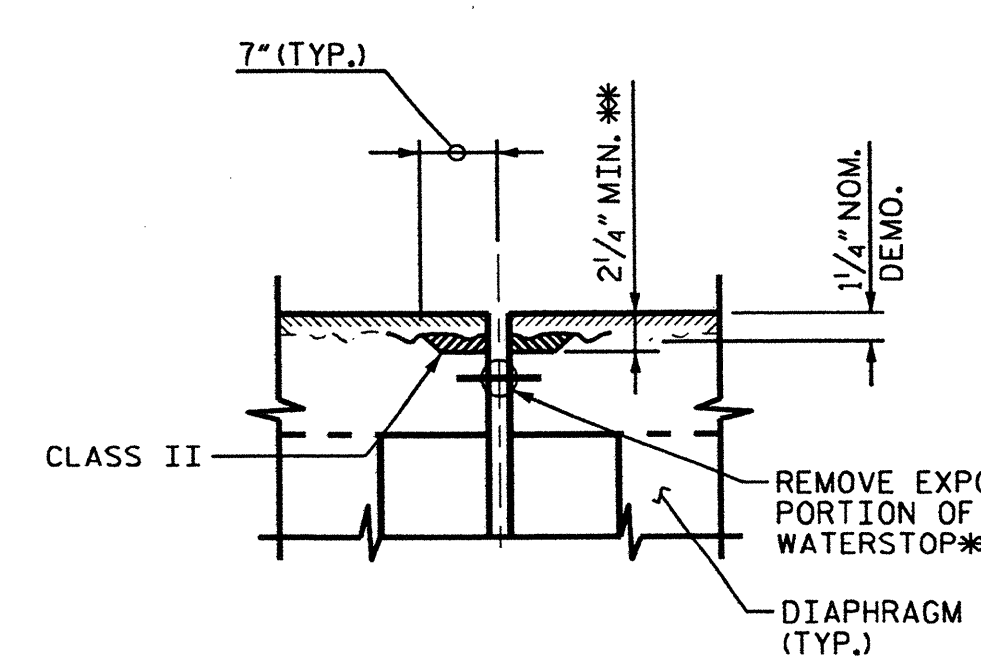

SECTION B-B
(MINIMUM EXISTING JOINT DEMOLITION)

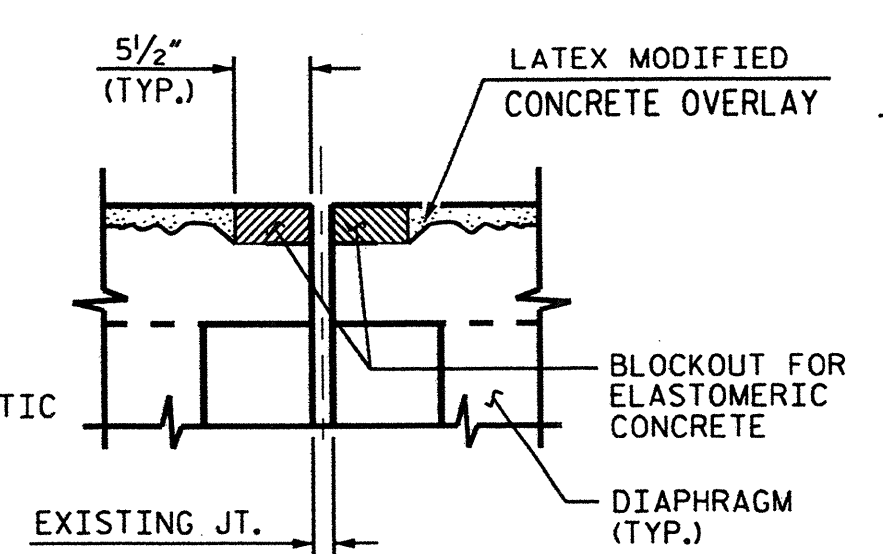

SECTION B-B
(PROPOSED EVAZOTE JOINT SEAL PRE-SAWED DIMENSIONS)

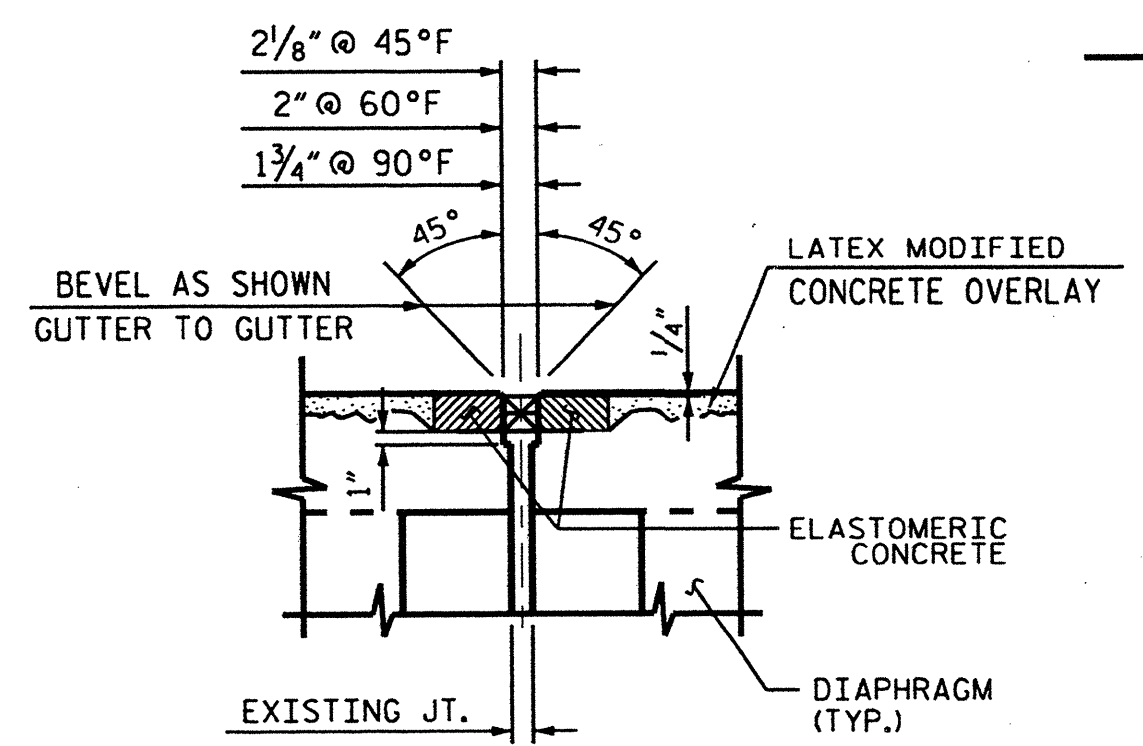

SECTION B-B
(PROPOSED EVAZOTE JOINT SEAL EXPANSION)

** ALL LOOSE AND UNSOUND CONCRETE SHALL BE REMOVED. IF THE EMBEDDED PORTION OF THE EXISTING PLASTIC WATERSTOP IS EXPOSED DURING REMOVAL OF UNSOUND CONCRETE, THE ENTIRE WATERSTOP SHALL BE REMOVED.

PROJECT NO. 17BP.1.P.3
 COUNTY: MARTIN
 DECK REPAIR BRIDGE NO. 7
 SHEET 3 OF 3

REVISIONS						SHEET NO. S-34
NO.	BY:	DATE:	NO.	BY:	DATE:	
1			3			TOTAL SHEETS 50
2			4			



TYPICAL SECTION AND JOINT DETAILS

DRAWN BY : K.H. COMPTON DATE : 9/11
 CHECKED BY : D. SNOKE DATE : 9/11

OAK CITY ←

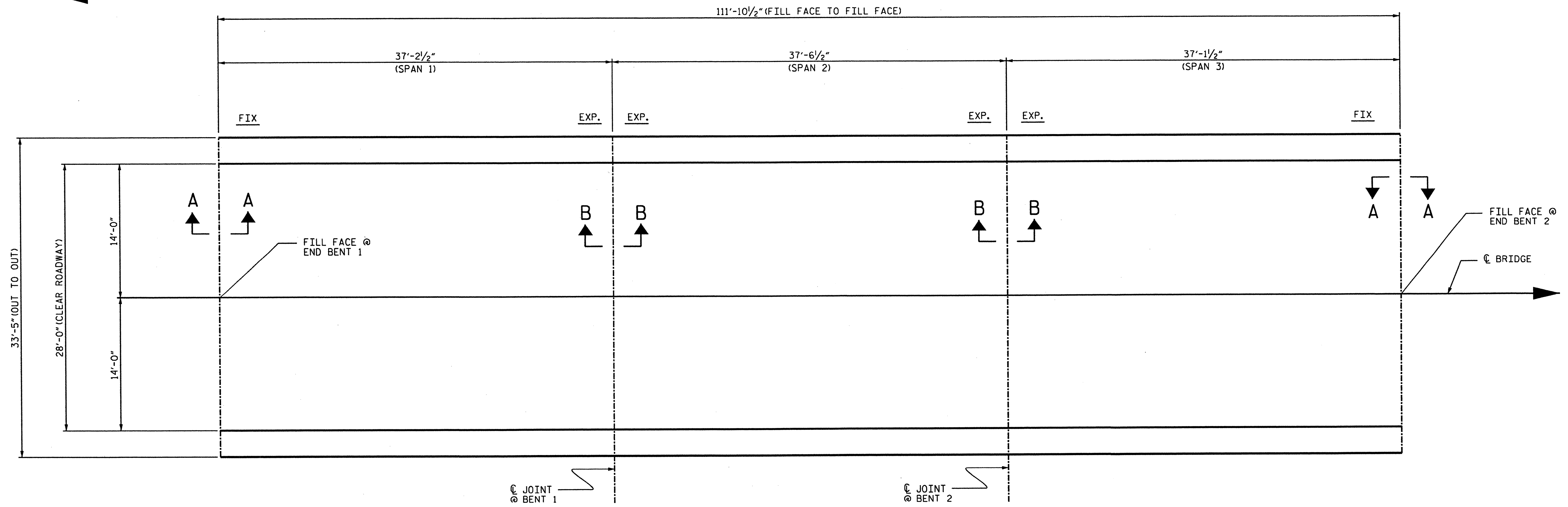
→ HAMILTON



 APPROX. AREA: CLASS II REPAIR
 APPROX. AREA: CLASS III REPAIR

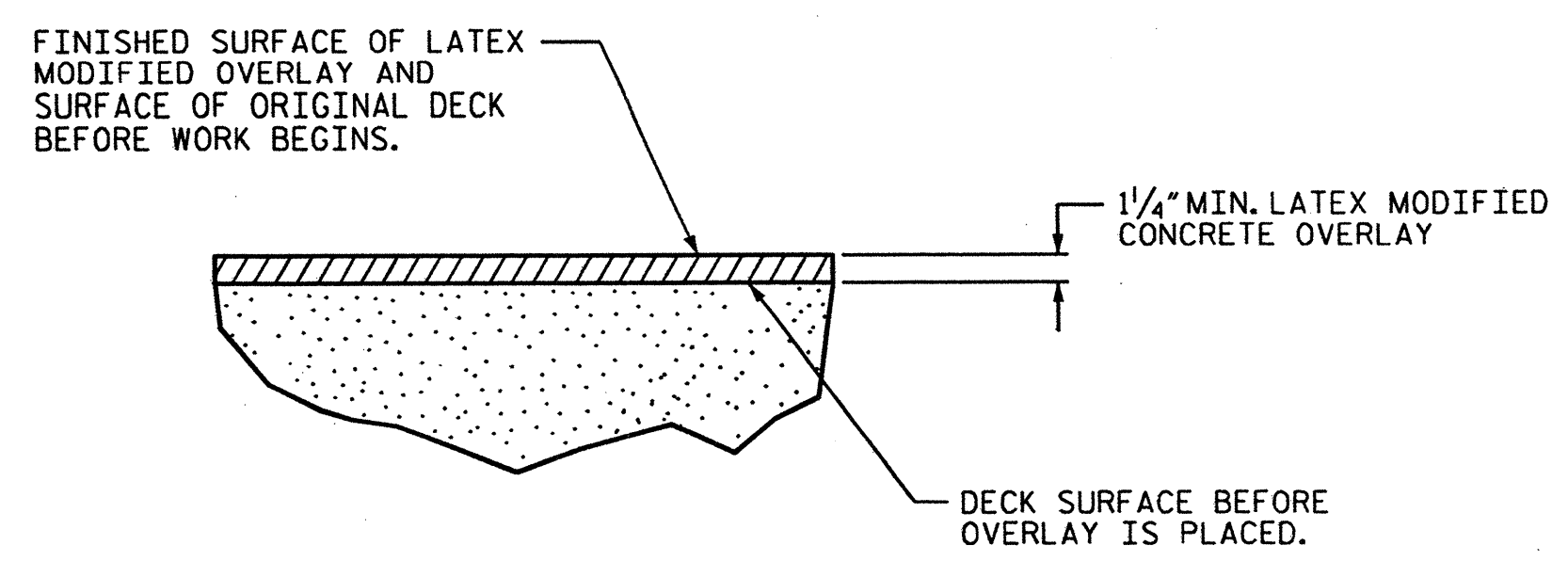

DETAIL FOR LATEX MODIFIED CONCRETE OVERLAY

PLAN OF SPANS- DECK REPAIRS
ENTIRE DECK TO BE SCARIFIED AND HYDRODEMOLITION

PROJECT NO. 17BP.1.P.3
 COUNTY: MARTIN
 DECK REPAIR BRIDGE NO: 12

TOTAL BILL OF MATERIAL									
DECK ** SCARIFICATION	CLASS I* SURFACE PREPARATION	CLASS II* SURFACE PREPARATION	CLASS III* SURFACE PREPARATION	HYDRO-DEMOLITION OF BRIDGE DECK	LATEX MODIFIED CONCRETE	PLACING & FINISHING LATEX MODIFIED CONCRETE	FOAM JOINT SEALS	GROOVING BRIDGE FLOORS	ASPHALT CONC. SURF. COURSE TYPE S9.5B
SO.YDS.	SO.YDS.	SO.YDS.	SO.YDS.	SO.YDS.	C.Y.	SO.YDS.	LUMP SUM	SO. FT.	TON
2,015	0	8.3	0	348	14.5	348	LUMP SUM	2,697	150

* QUANTITIES ARE SHOWN FOR INFORMATIONAL PURPOSES ONLY. IF ANY CLASS III LOCATIONS ARE ENCOUNTERED PRIOR TO OR DURING HYDRO-DEMOLITION, SEE TYP. "BLOW THRU" CONTAINMENT AND FALSEWORK DETAILS.
 ** INCLUDES MILLING OF ROADWAY PAVEMENT.

DRAWN BY : K.H. COMPTON DATE : 9/11
 CHECKED BY : D. SNOKE DATE : 9/11

SHEET 1 OF 3

STATE OF NORTH CAROLINA
DEPARTMENT OF TRANSPORTATION
RALEIGH



PLAN OF BRIDGE AND BILL OF MATERIALS

28'-0" CLEAR ROADWAY (90°-00' SKEW)

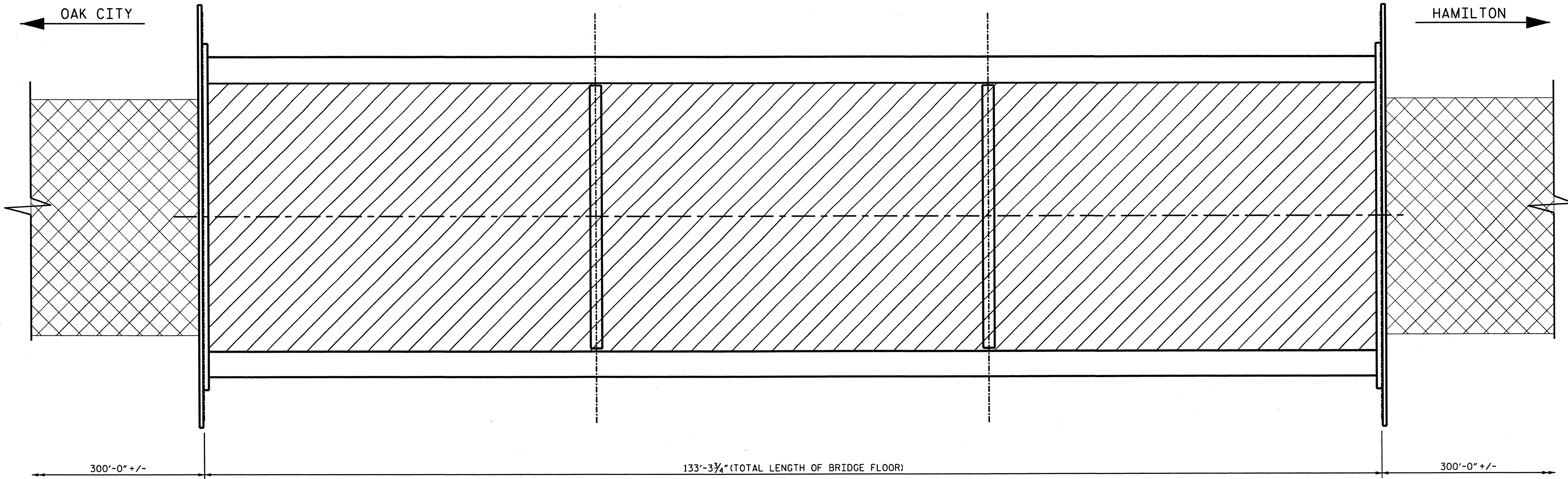
REVISIONS						SHEET NO.
NO.	BY:	DATE:	NO.	BY:	DATE:	S-35
1			3			TOTAL SHEETS
2			4			50



PLAN

-  DECK SCARIFICATION AND HYDRODEMOLITION
-  MILLING OF ROADWAY APPROACH

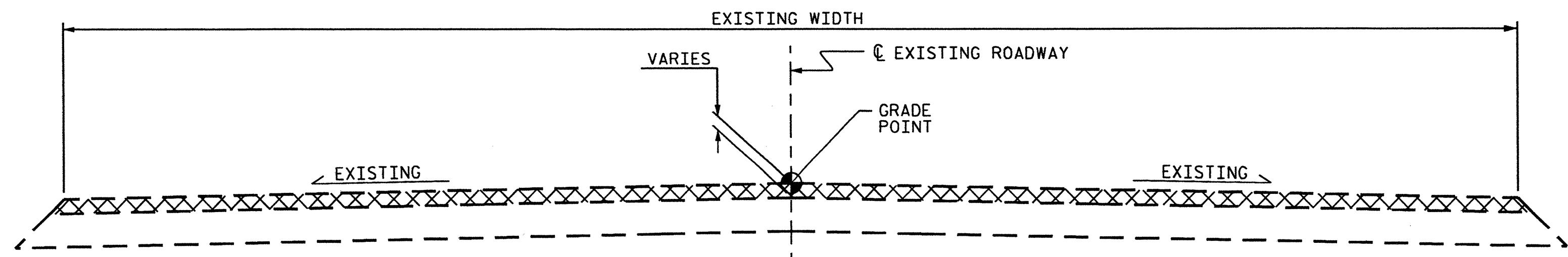

TYPICAL ROADWAY MILLING SECTION

C1 PROPOSED VARIABLE DEPTH ASPHALT CONCRETE SURFACE COURSE, TYPE SF 9.5B AT AN AVERAGE RATE OF 110 LBS. PER SQ. YD. PER 1" DEPTH, TO BE PLACED IN LAYERS NOT LESS THAN 1" IN DEPTH OR GREATER THAN 1 1/2" IN DEPTH.

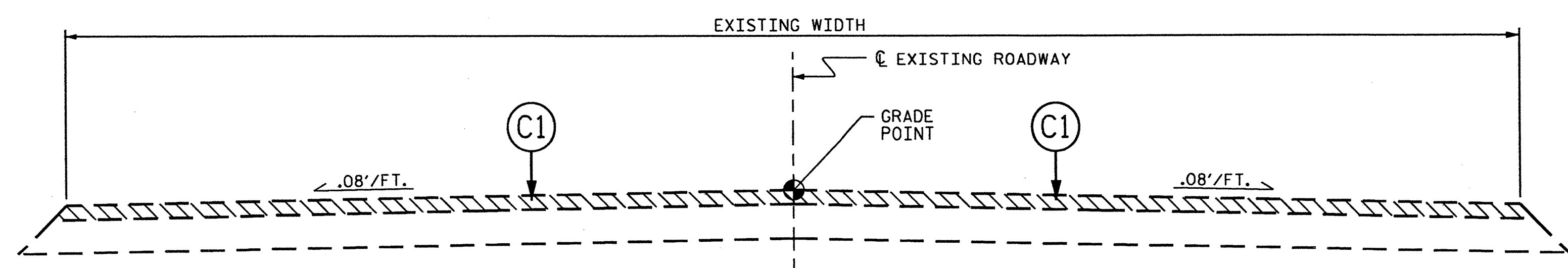

TYPICAL ROADWAY SECTION

PROJECT NO. 17BP.1.P.3
 COUNTY: MARTIN
 DECK REPAIR BRIDGE NO: 12
 SHEET 2 OF 3

STATE OF NORTH CAROLINA
 DEPARTMENT OF TRANSPORTATION
 RALEIGH
 TYPICAL ROADWAY
 SECTION AND
 MILLING DETAILS

REVISIONS						SHEET NO.
NO.	BY:	DATE:	NO.	BY:	DATE:	S-36
1			3			TOTAL SHEETS
2			4			50

DRAWN BY : K.H. COMPTON DATE : 9/11
 CHECKED BY : D. SNOKE DATE : 9/11

NOT TO SCALE

10-NOV-2011 10:10
 Z:\Squid C\Deck\Division 1\Proj01.dns\DKREHAB_S70012.dgn
 cmuller

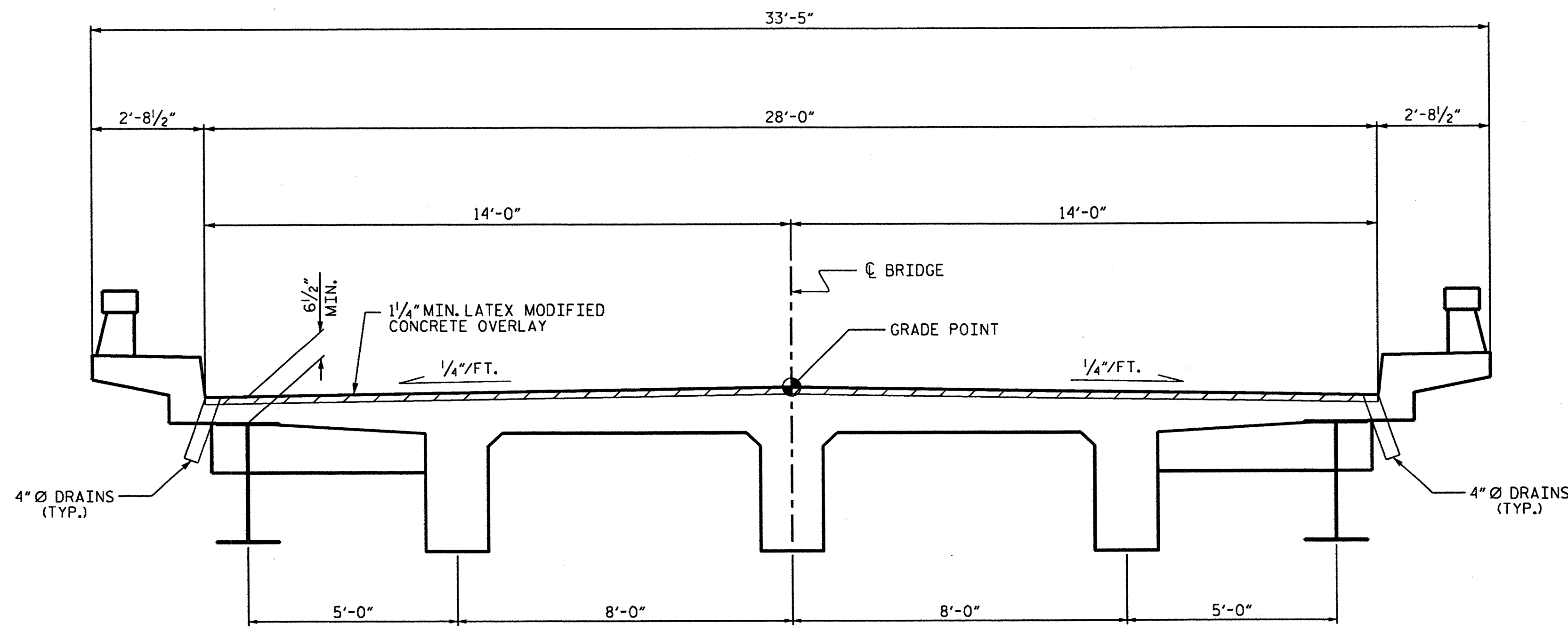

TYPICAL SECTION

ELASTOMERIC CONCRETE	
BENTS	10.7 (CU. FT.)
END BENTS	0 (CU. FT.)
* TOTAL	10.7 (CU. FT.)

* BASED ON THE MINIMUM BLOCKOUT SHOWN.

NOTES

- EXISTING DECK DRAINS SHALL BE SEALED PRIOR TO BEGINNING REPAIR OF BRIDGE DECKS WITH LATEX MODIFIED CONCRETE. SEE SPECIAL PROVISIONS.
- FOR HYDRO-DEMOLITION, SEE SPECIAL PROVISIONS.
- THE CONTRACTOR MUST COLLECT, TREAT AND DISPOSE OF RUN-OFF WATER FROM THE HYDRO-DEMOLITION PROCESS, SEE SPECIAL PROVISIONS.
- THE BOUNDARIES OF AREAS IDENTIFIED FOR CLASS III SURFACE PREPARATION ARE APPROXIMATE. THE CONTRACTOR SHALL PROVIDE A METHOD OF HANDLING UNEXPECTED BLOW THROUGH OF DECK. SEE DETAIL.
- FOR OVERLAY OF BRIDGE DECKS WITH LATEX MODIFIED CONCRETE, SEE SPECIAL PROVISIONS.
- SEE SPECIAL PROVISIONS FOR SURFACE PREPARATION.
- EXISTING BRIDGE INFORMATION BASED ON BEST AVAILABLE DATA.
- FOR FOAM JOINT SEAL SEE SPECIAL PROVISIONS.
- THE INSTALLED FOAM JOINT SEAL SHALL BE WATER TIGHT.
- NOMINAL UNCOMPRESSED SEAL WIDTH OF FOAM JOINT SEAL SHALL BE 2 1/2" AT BENTS.
- THE CONTRACTOR WILL NOT BE PERMITTED TO FORM THE JOINT FOR THE FOAM JOINT SEAL IN LIEU OF SAWING THE JOINT

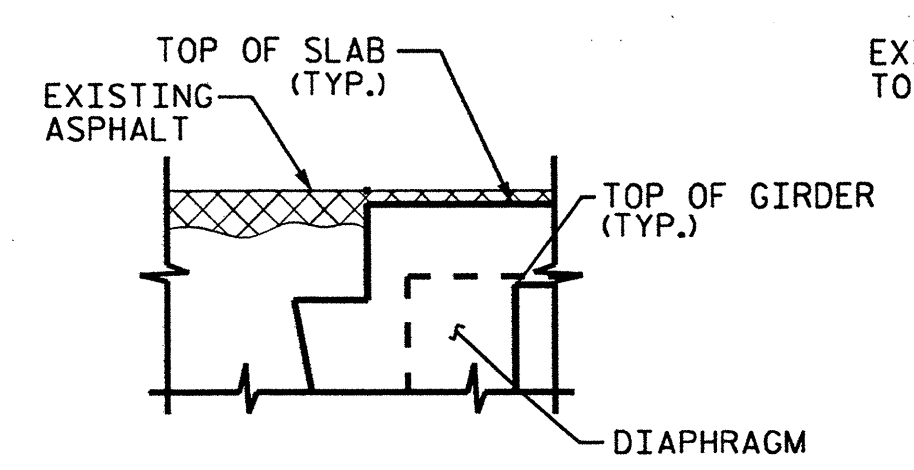

SECTION A-A
(EXISTING JOINT)

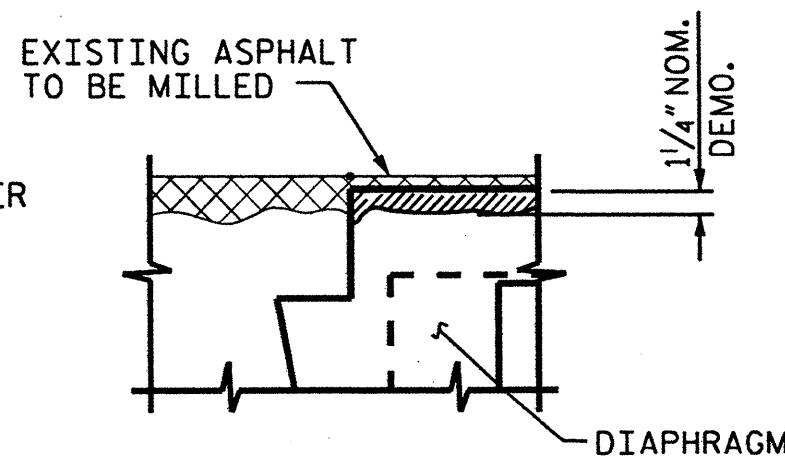

SECTION A-A
(MINIMUM EXISTING JOINT DEMOLITION)

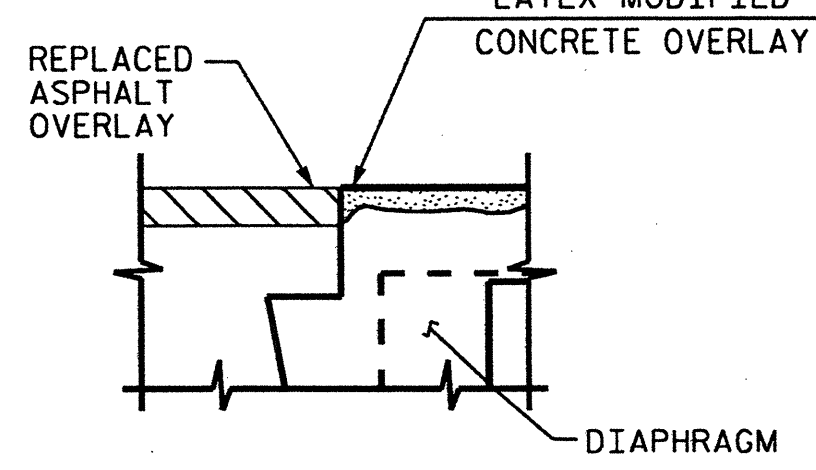

SECTION A-A
(PROPOSED JOINT)

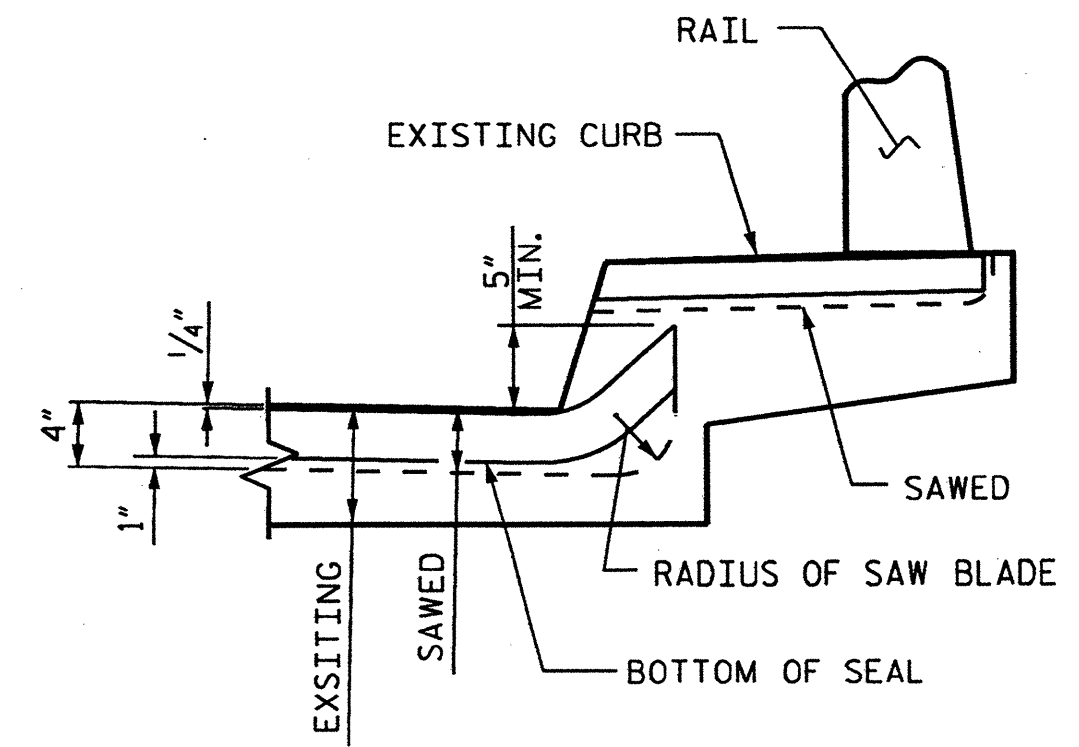

SECTION C-C

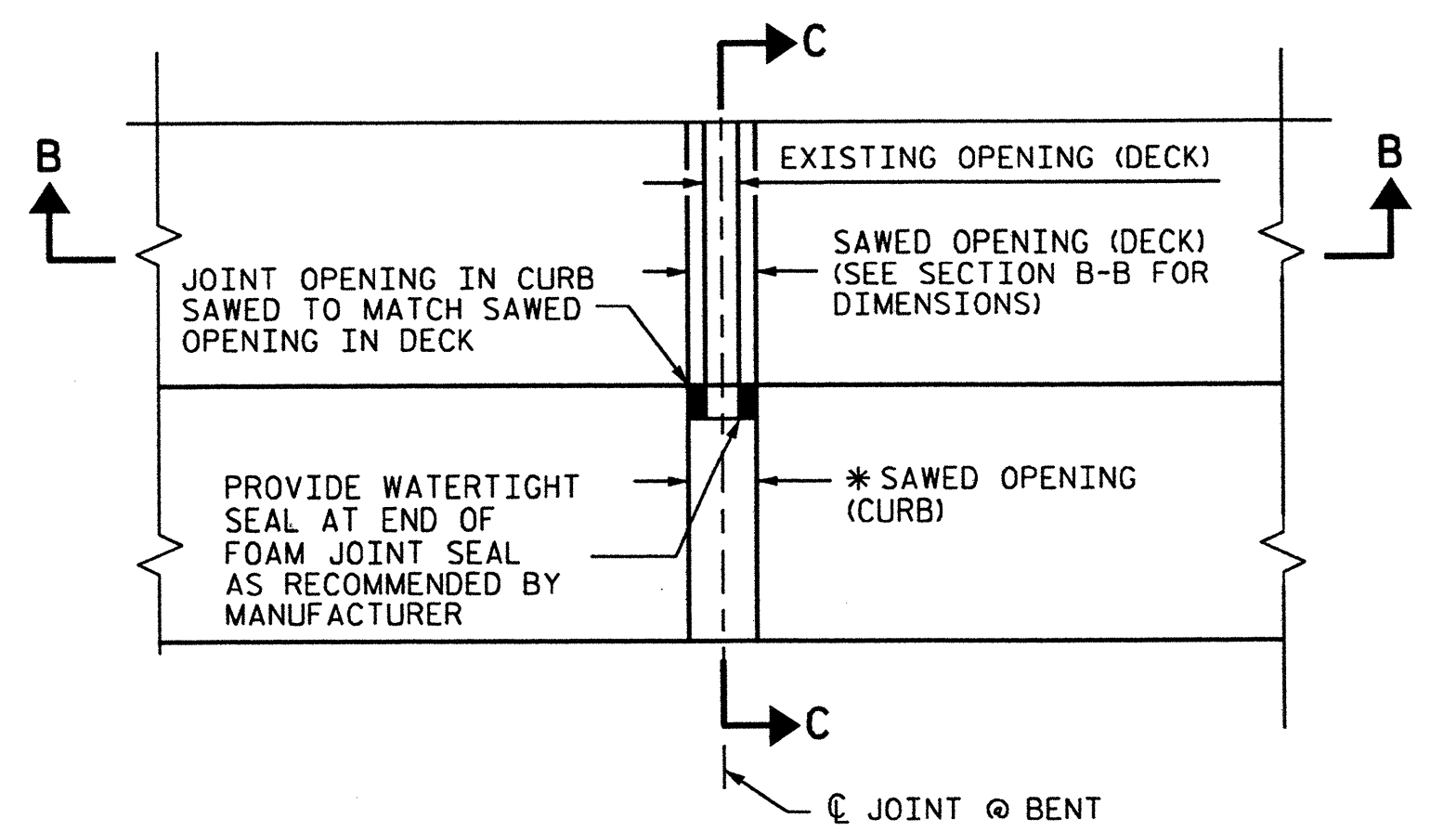

FOAM JOINT SEAL DETAILS
* SEAL WIDTH IN CURB TO BE DETERMINED BY THE ENGINEER

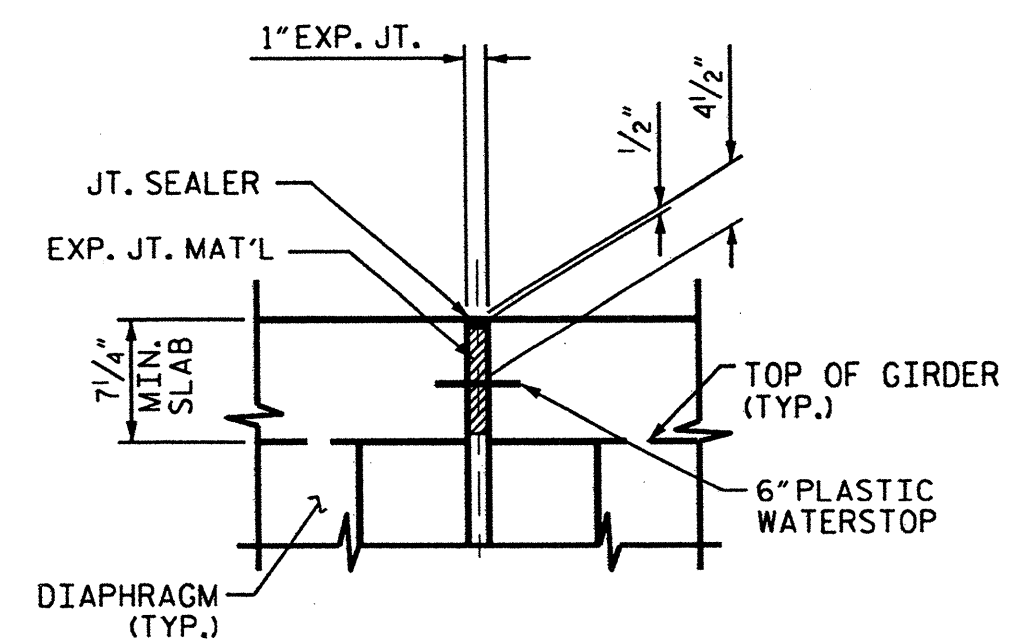

SECTION B-B
(EXISTING JOINT)

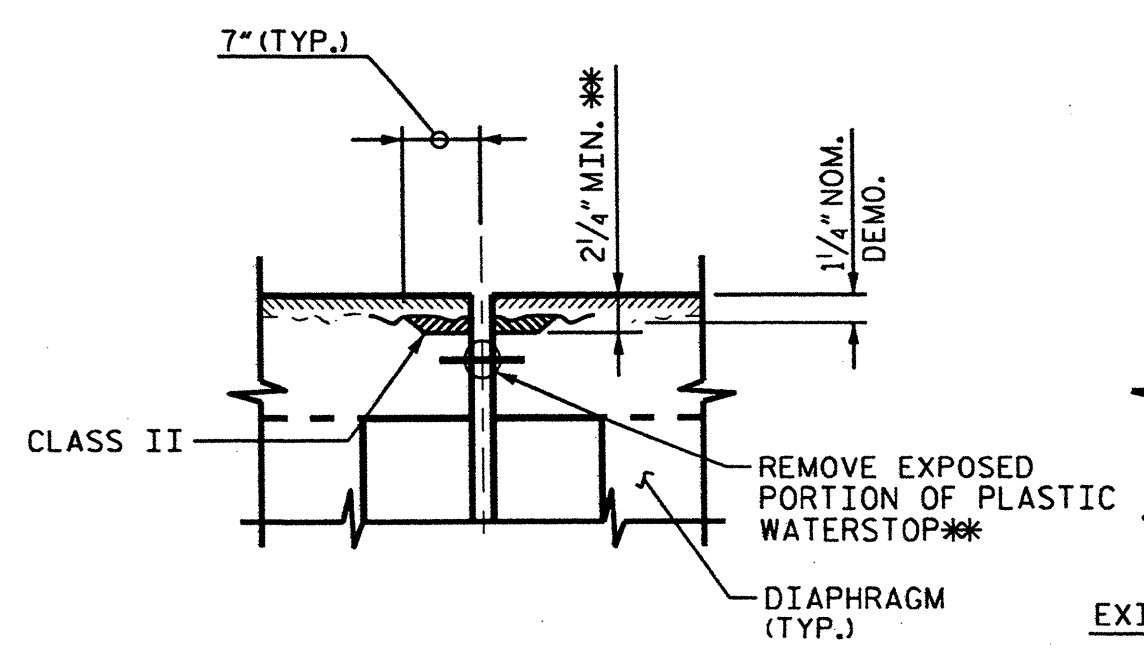

SECTION B-B
(MINIMUM EXISTING JOINT DEMOLITION)

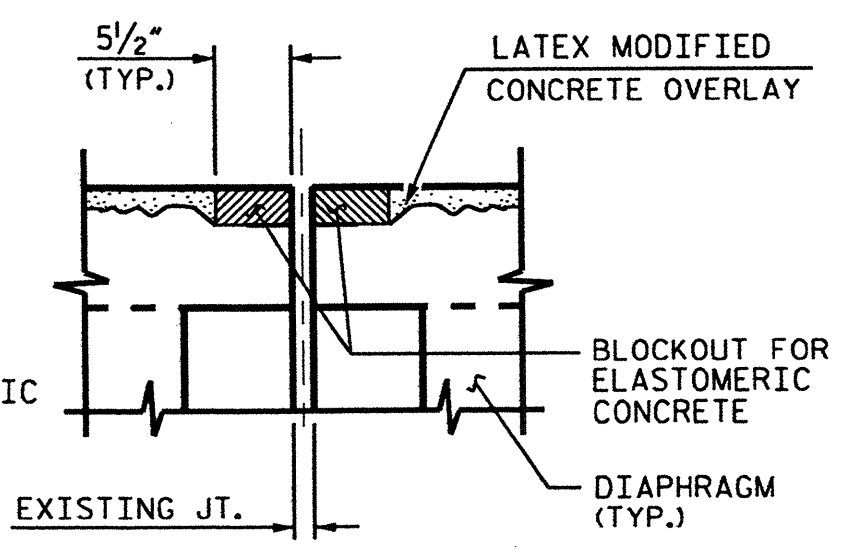

SECTION B-B
(PROPOSED EVAZOTE JOINT SEAL PRE-SAWED DIMENSIONS)

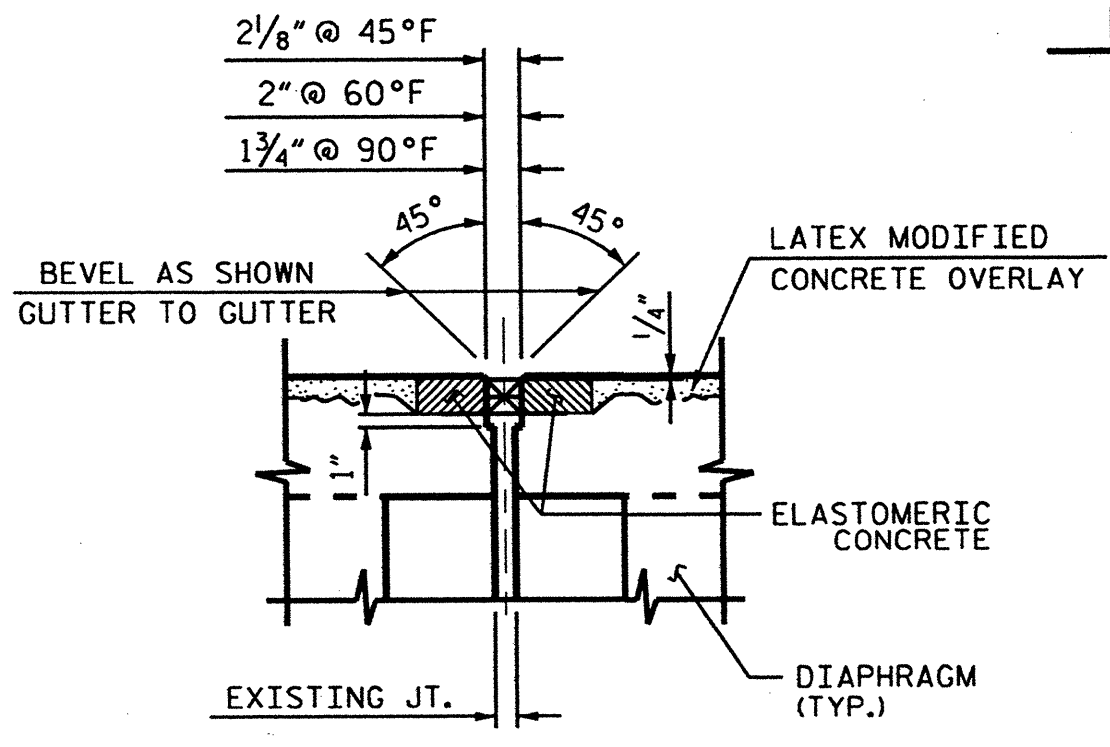

SECTION B-B
(PROPOSED EVAZOTE JOINT SEAL EXPANSION)

** ALL LOOSE AND UNSOUND CONCRETE SHALL BE REMOVED. IF THE EMBEDDED PORTION OF THE EXISTING PLASTIC WATERSTOP IS EXPOSED DURING REMOVAL OF UNSOUND CONCRETE, THE ENTIRE WATERSTOP SHALL BE REMOVED.

PROJECT NO. 17BP.1.P.3
COUNTY: MARTIN
DECK REPAIR BRIDGE NO. 12
SHEET 3 OF 3

STATE OF NORTH CAROLINA
DEPARTMENT OF TRANSPORTATION
RALEIGH

TYPICAL SECTION AND JOINT DETAILS

REVISIONS						SHEET NO. S-37
NO.	BY:	DATE:	NO.	BY:	DATE:	
1			3			TOTAL SHEETS 50
2			4			

DRAWN BY : K.H. COMPTON DATE : 9/11
CHECKED BY : D. SNOKE DATE : 9/11

OAK CITY ←

SR 1333 →

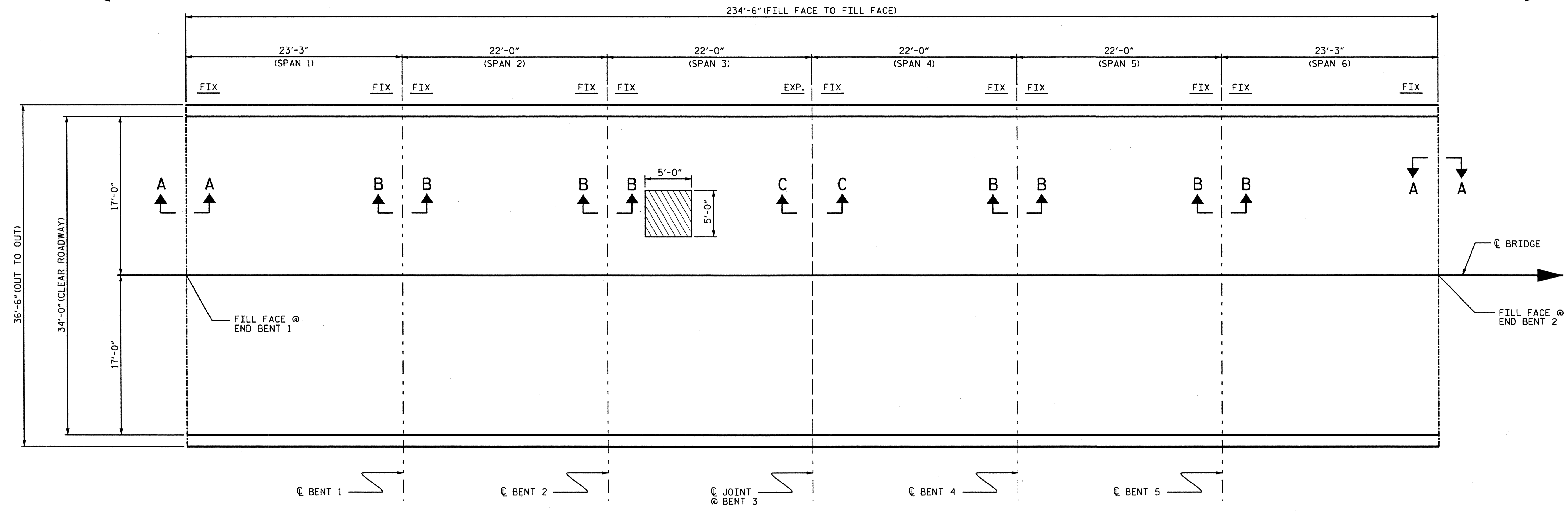

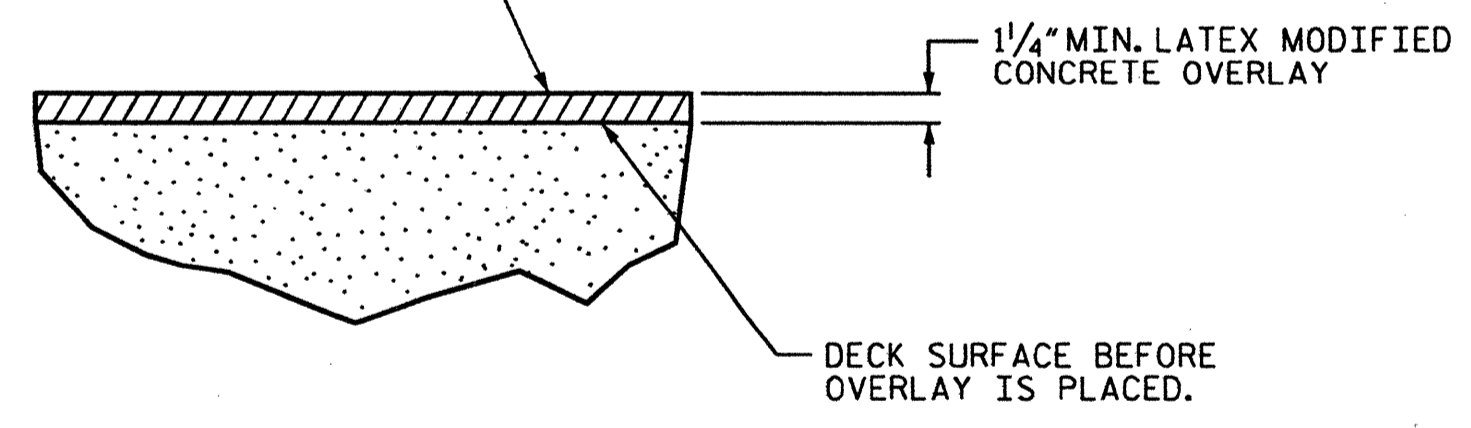

FINISHED SURFACE OF LATEX MODIFIED OVERLAY AND SURFACE OF ORIGINAL DECK BEFORE WORK BEGINS.



DETAIL FOR LATEX MODIFIED CONCRETE OVERLAY

PLAN OF SPANS- DECK REPAIRS
ENTIRE DECK TO BE SCARIFIED AND HYDRODEMOLITION

 APPROX. AREA: CLASS II REPAIR
 APPROX. AREA: CLASS III REPAIR

PROJECT NO. 17BP.1.P.3
COUNTY: MARTIN
DECK REPAIR BRIDGE NO: 14
SHEET 1 OF 3

TOTAL BILL OF MATERIAL									
DECK** SCARIFICATION	CLASS I* SURFACE PREPARATION	CLASS II* SURFACE PREPARATION	CLASS III* SURFACE PREPARATION	HYDRO-DEMOLITION OF BRIDGE DECK	LATEX MODIFIED CONCRETE	PLACING & FINISHING LATEX MODIFIED CONCRETE	EVAZOTE JOINT SEALS	GROOVING BRIDGE FLOORS	ASPHALT CONC. SURF. COURSE TYPE S9.5B
SO.YDS.	SO.YDS.	SO.YDS.	SO.YDS.	SO.YDS.	C.Y.	SO.YDS.	LUMP SUM	SO. FT.	TON
1,064	0	2.8	0	886	36.9	886	LUMP SUM	7,208	16

* QUANTITIES ARE SHOWN FOR INFORMATIONAL PURPOSES ONLY. IF ANY CLASS III LOCATIONS ARE ENCOUNTERED PRIOR TO OR DURING HYDRO-DEMOLITION, SEE TYP. "BLOW THRU" CONTAINMENT AND FALSEWORK DETAILS.
** INCLUDES MILLING OF ROADWAY PAVEMENT.

DRAWN BY: K.H. COMPTON DATE: 9/11
CHECKED BY: D. SNOKE DATE: 9/11

STATE OF NORTH CAROLINA
DEPARTMENT OF TRANSPORTATION
RALEIGH



PLAN OF BRIDGE AND BILL OF MATERIALS

34'-0" CLEAR ROADWAY (90°-00' SKEW)

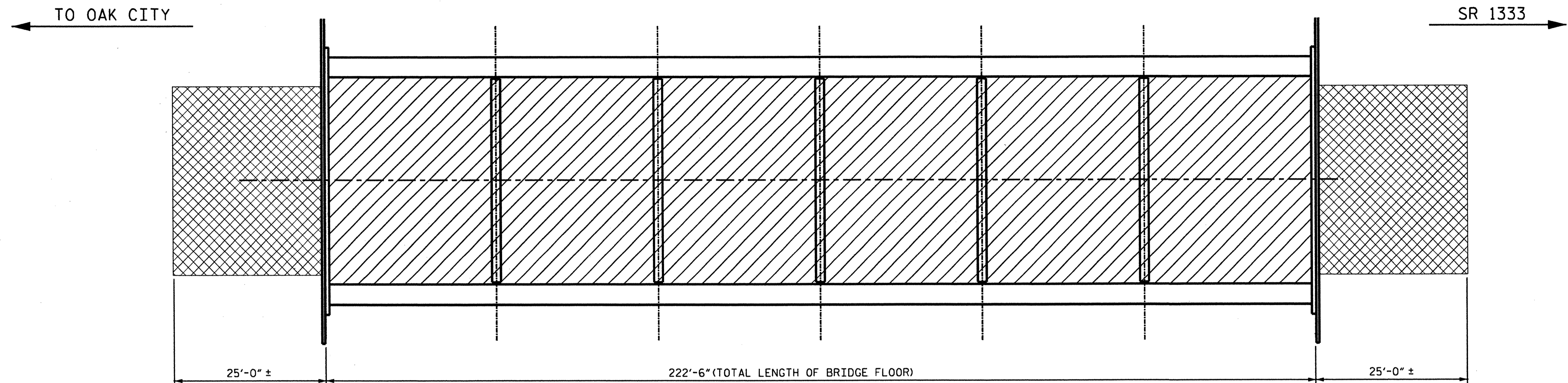
REVISIONS						SHEET NO.
NO.	BY:	DATE:	NO.	BY:	DATE:	S-38
1			3			TOTAL SHEETS 50
2			4			



PLAN

 DECK SCARIFICATION AND HYDRODEMOLITION
 MILLING OF ROADWAY APPROACH

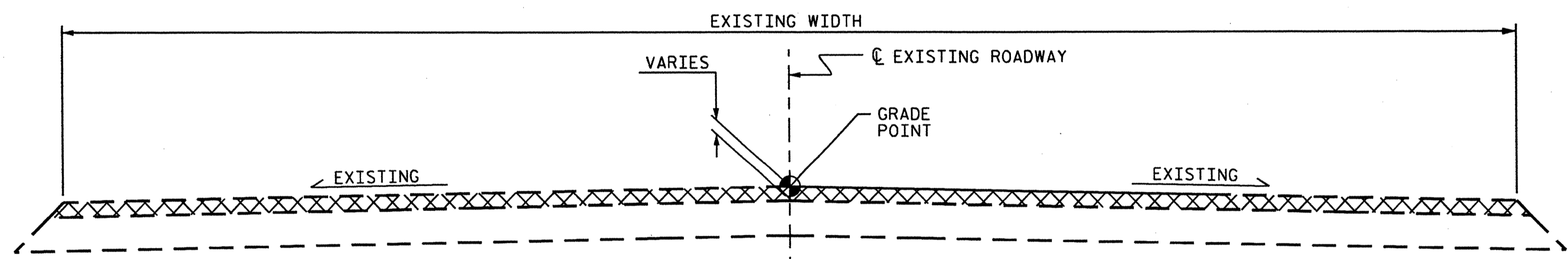

TYPICAL ROADWAY MILLING SECTION

C1 PROPOSED VARIABLE DEPTH ASPHALT CONCRETE SURFACE COURSE, TYPE SF 9.5B AT AN AVERAGE RATE OF 110 LBS. PER SQ. YD. PER 1" DEPTH, TO BE PLACED IN LAYERS NOT LESS THAN 1" IN DEPTH OR GREATER THAN 1/2" IN DEPTH.

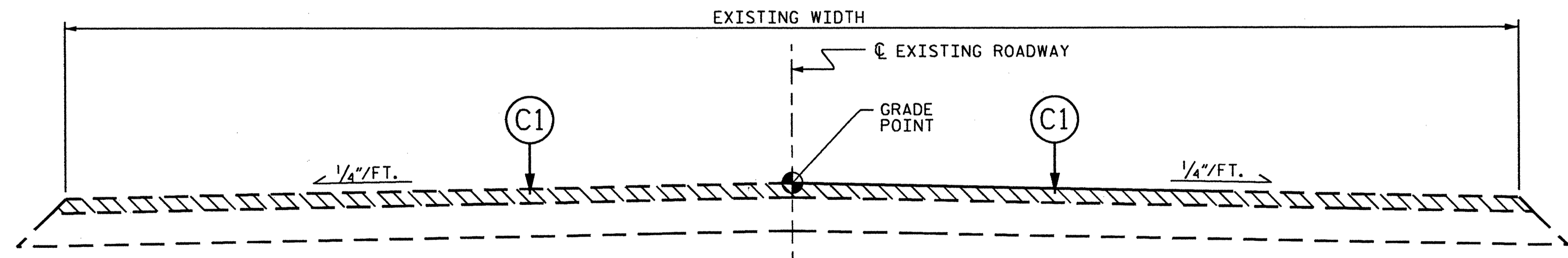

TYPICAL ROADWAY SECTION

PROJECT NO. 17BP.1.P.3
 COUNTY: MARTIN
 DECK REPAIR BRIDGE NO. 14
 SHEET 2 OF 3

STATE OF NORTH CAROLINA
 DEPARTMENT OF TRANSPORTATION
 RALEIGH
 TYPICAL ROADWAY
 SECTION AND
 MILLING DETAILS

DRAWN BY : K.H. COMPTON DATE : 9/11
 CHECKED BY : D. SNOKE DATE : 9/11

10-NOV-2011 10:10
 Z:\Squad\C\Deck\Division 1\Proj01.dns\DKREHAB.570014.dgn
 dmiller

NOT TO SCALE

REVISIONS						SHEET NO.
NO.	BY:	DATE:	NO.	BY:	DATE:	S-39
1			3			TOTAL SHEETS
2			4			50

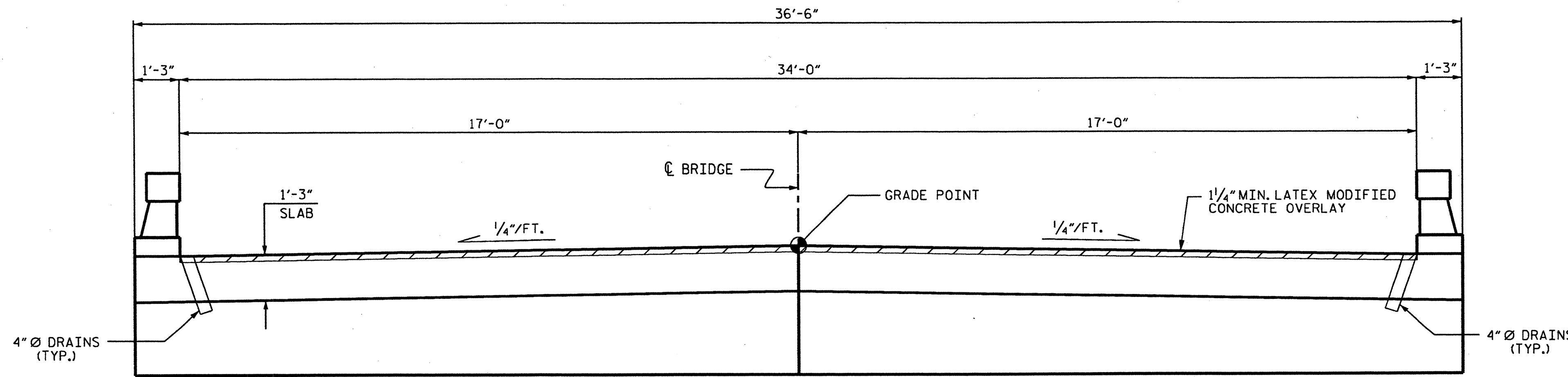

TYPICAL SECTION

NOTES

EXISTING DECK DRAINS SHALL BE SEALED PRIOR TO BEGINNING REPAIR OF BRIDGE DECKS WITH LATEX MODIFIED CONCRETE. SEE SPECIAL PROVISIONS.

FOR HYDRO-DEMOLITION, SEE SPECIAL PROVISIONS.

THE CONTRACTOR MUST COLLECT, TREAT AND DISPOSE OF RUN-OFF WATER FROM THE HYDRO-DEMOLITION PROCESS, SEE SPECIAL PROVISIONS.

THE BOUNDARIES OF AREAS IDENTIFIED FOR CLASS III SURFACE PREPARATION ARE APPROXIMATE. THE CONTRACTOR SHALL PROVIDE A METHOD OF HANDLING UNEXPECTED BLOW THROUGH OF DECK. SEE DETAIL.

FOR OVERLAY OF BRIDGE DECKS WITH LATEX MODIFIED CONCRETE, SEE SPECIAL PROVISIONS.

SEE SPECIAL PROVISIONS FOR SURFACE PREPARATION.

EXISTING BRIDGE INFORMATION BASED ON BEST AVAILABLE DATA.

FOR EVAZOTE JOINT SEAL SEE SPECIAL PROVISIONS.

THE INSTALLED EVAZOTE JOINT SEAL SHALL BE WATER TIGHT.

NOMINAL UNCOMPRESSED SEAL WIDTH OF EVAZOTE JOINT SEAL SHALL BE 2 1/2" AT BENTS.

THE CONTRACTOR WILL NOT BE PERMITTED TO FORM THE JOINT FOR THE EVAZOTE JOINT SEAL IN LIEU OF SAWING THE JOINT

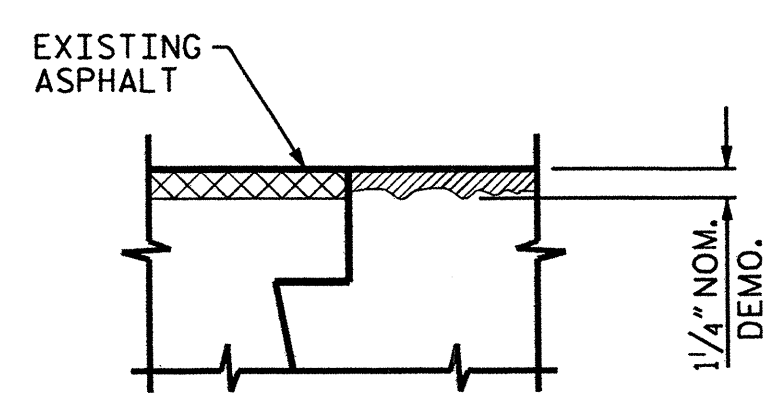

**SECTION A-A
(EXISTING JOINT)**

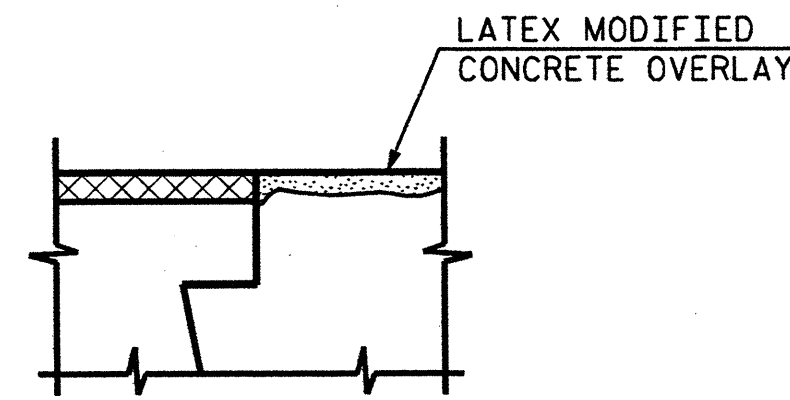

**SECTION A-A
(PROPOSED JOINT)**

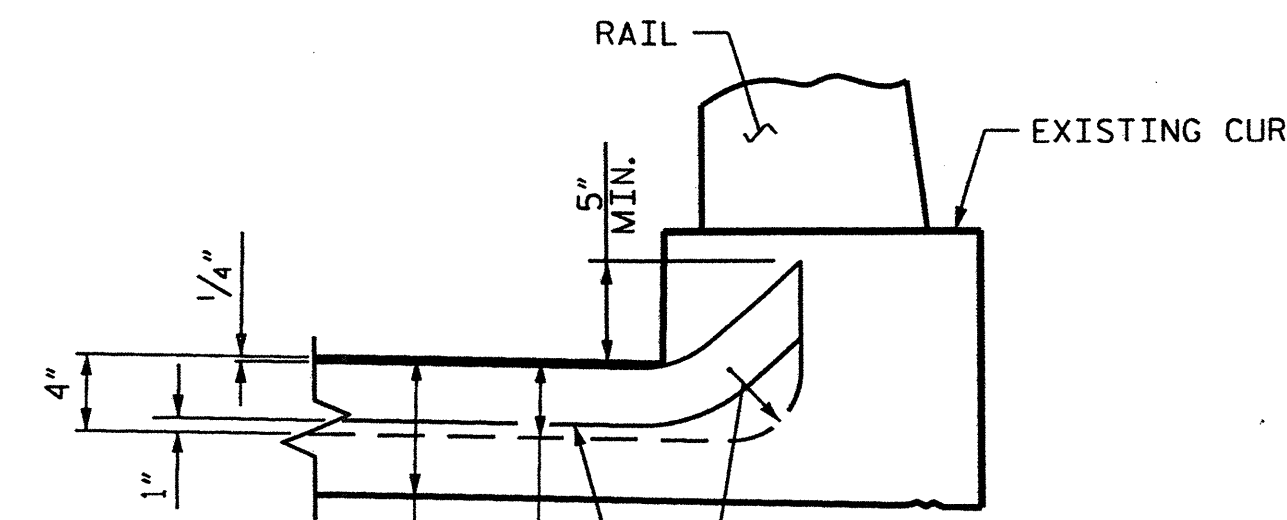

SECTION D-D

ELASTOMERIC CONCRETE		
BENTS	6.5	(CU. FT.)
END BENTS	0	(CU. FT.)
* TOTAL	6.5	(CU. FT.)

* BASED ON THE MINIMUM BLOCKOUT SHOWN.

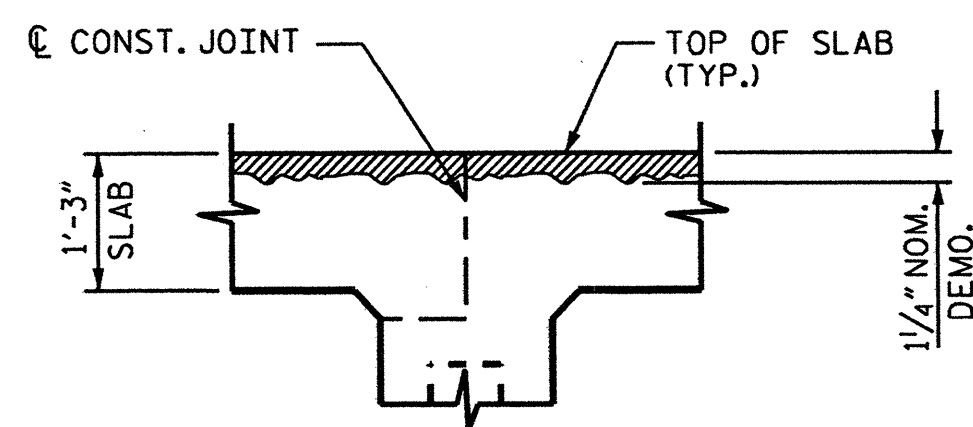

**SECTION B-B
(EXISTING JOINT)**

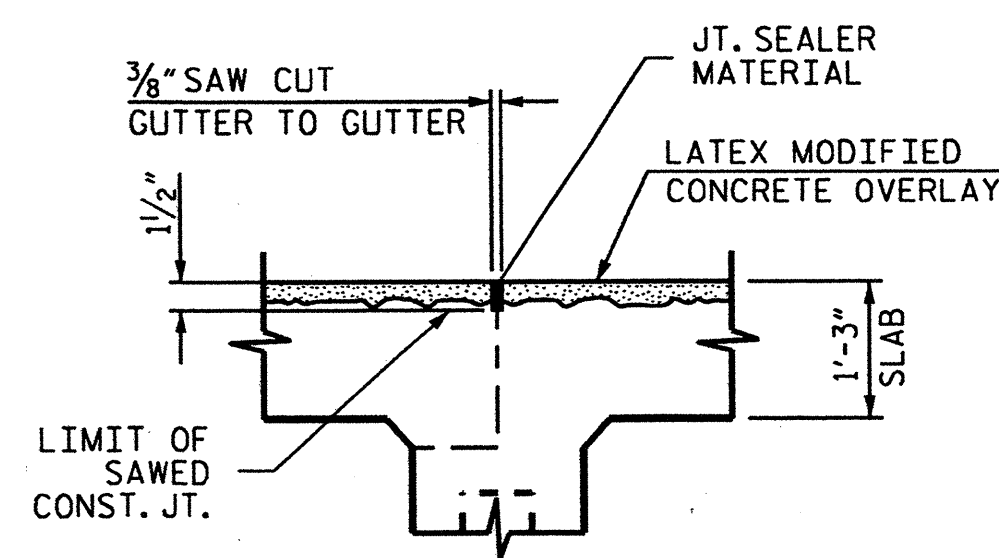

**SECTION B-B
(PROPOSED JOINT)**

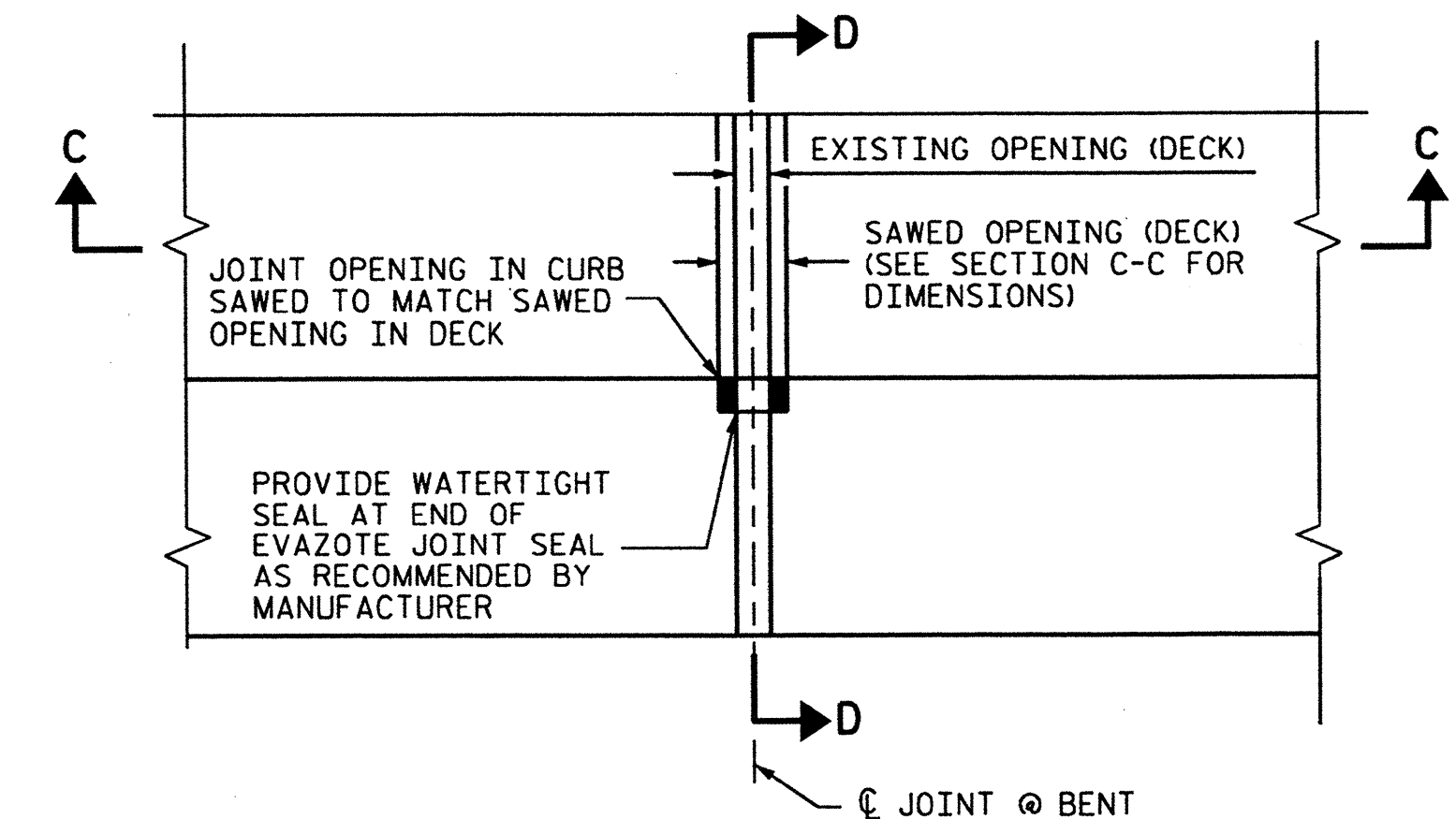

EVAZOTE JOINT SEAL DETAILS

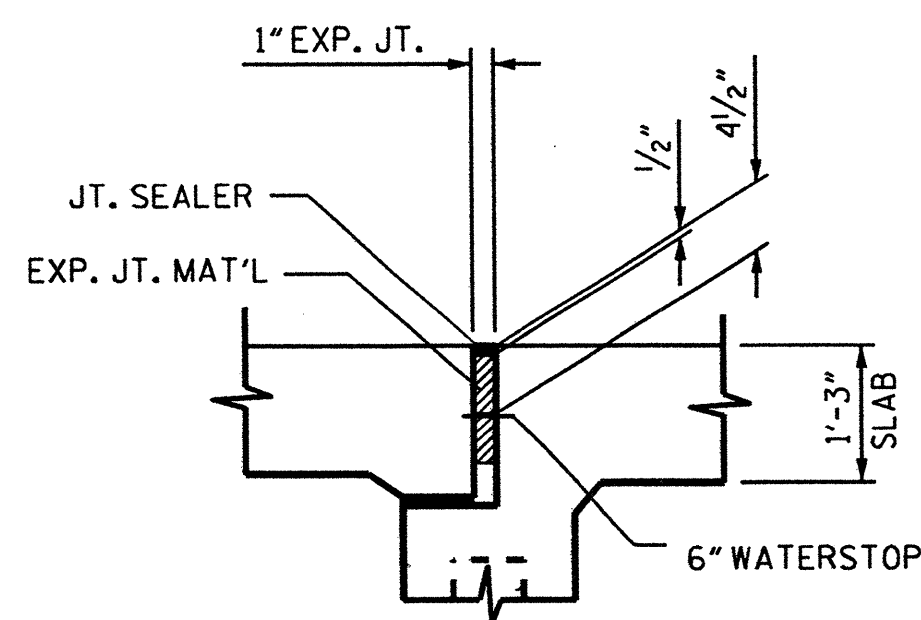

**SECTION C-C
(EXISTING JOINT)**

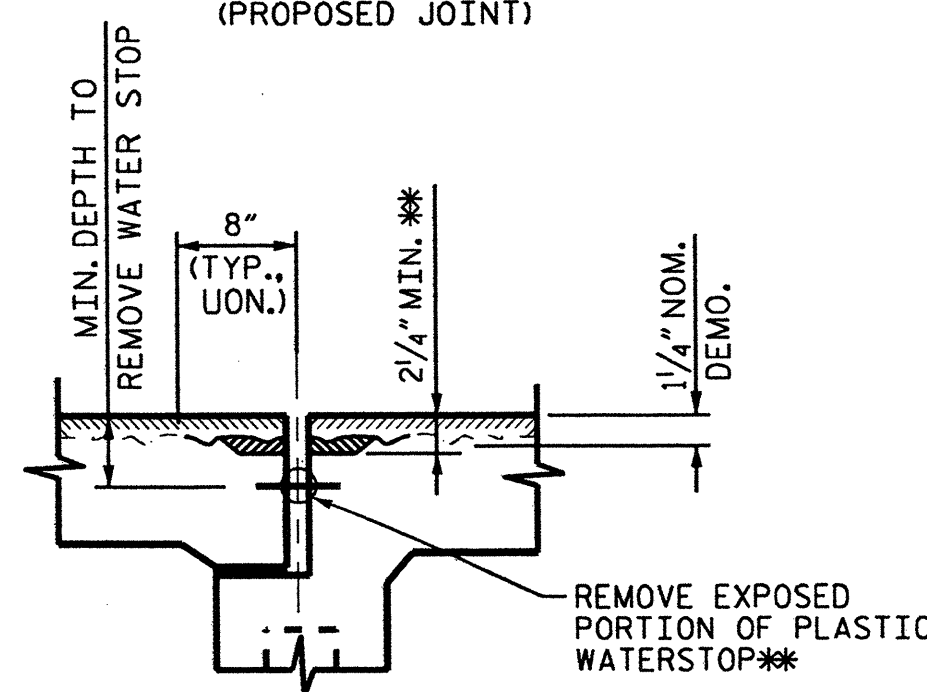

**SECTION C-C
(MINIMUM EXISTING JOINT DEMOLITION)**

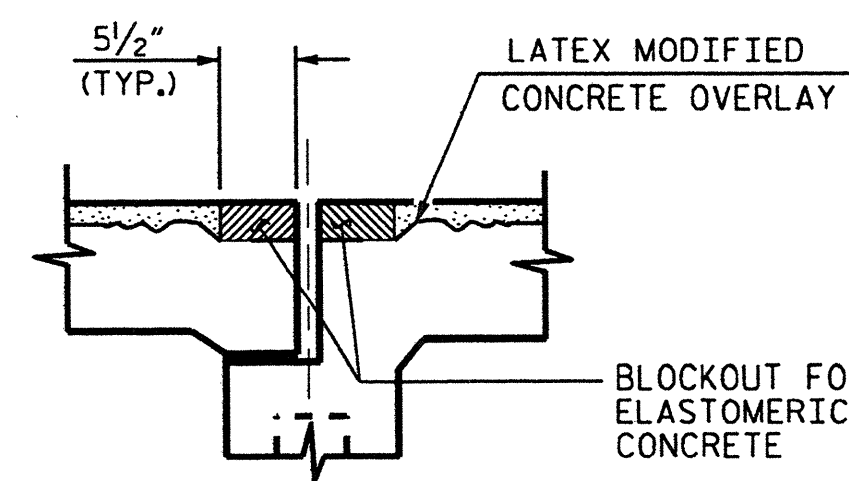

**SECTION C-C
(PROPOSED FOAM JOINT SEAL PRE-SAWED DIMENSIONS)**

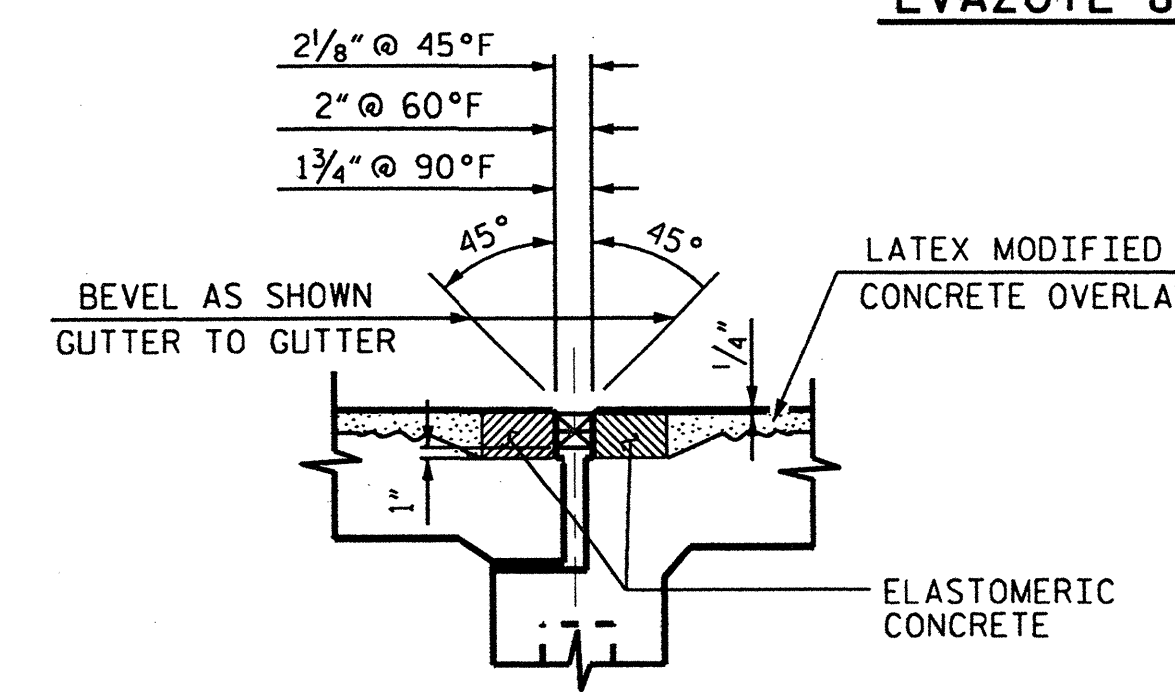

**SECTION C-C
(PROPOSED FOAM JOINT SEAL EXPANSION)**

** ALL LOOSE AND UNSOUND CONCRETE SHALL BE REMOVED. IF THE EMBEDDED PORTION OF THE EXISTING PLASTIC WATERSTOP IS EXPOSED DURING REMOVAL OF UNSOUND CONCRETE, THE ENTIRE WATERSTOP SHALL BE REMOVED.

PROJECT NO. 17BP.1.P.3
 COUNTY: MARTIN
 DECK REPAIR BRIDGE NO. 14
 SHEET 3 OF 3

REVISIONS						SHEET NO.
NO.	BY:	DATE:	NO.	BY:	DATE:	S-40
1			3			TOTAL SHEETS
2			4			50

DRAWN BY : K.H. COMPTON DATE : 9/11
 CHECKED BY : D. SNOKE DATE : 9/11

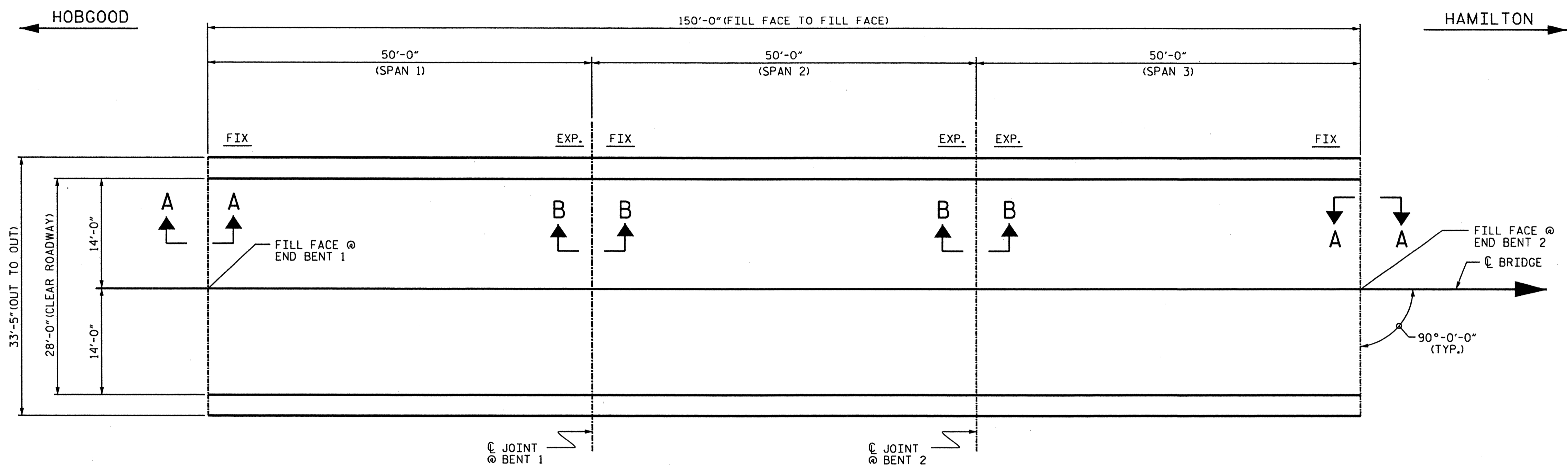

PLAN OF SPANS- DECK REPAIRS

APPROX. AREA: CLASS II REPAIR
 APPROX. AREA: CLASS III REPAIR

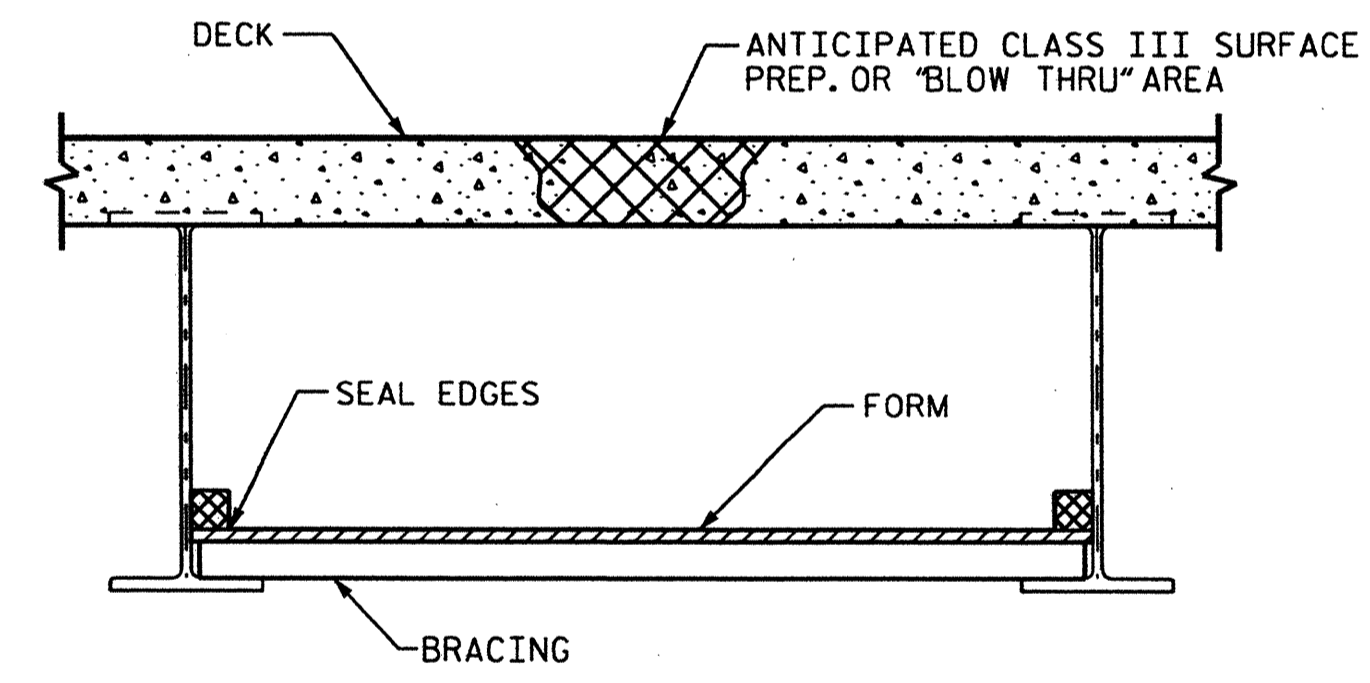

TYP. "BLOW THRU" CONTAINMENT AND FORMWORK

A METHOD TO CAPTURE WATER AND DEBRIS FROM BLOW THRU DURING HYDRO-DEMOLITION SHALL BE INSTALLED IN AREAS INDICATED AS CLASS III SURFACE PREPARATION.
 SUBMIT DETAILS OF PROPOSED FORM WORK FOR APPROVAL PRIOR TO BEGINNING WORK.
 COST FOR INSTALLING AND REMOVING FORM WORK SHALL BE INCIDENTAL TO THE PRICE PER SQ. YARD OF HYDRO-DEMOLITION.

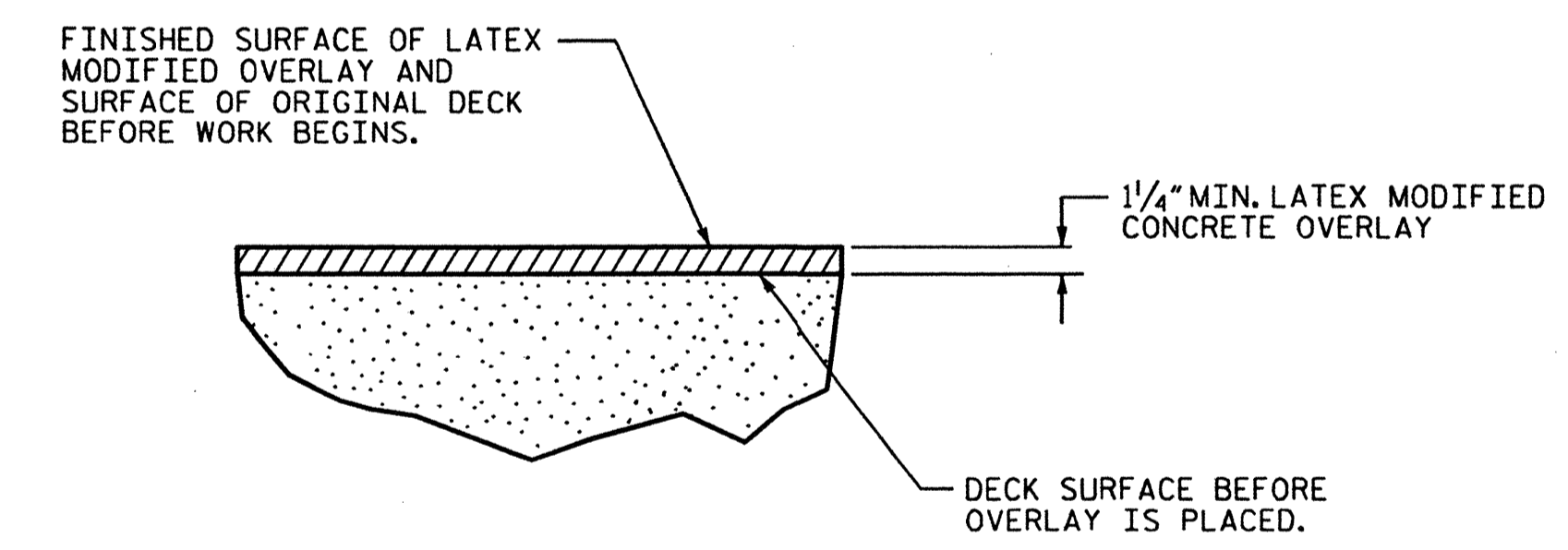

DETAIL FOR LATEX MODIFIED CONCRETE OVERLAY

TOTAL BILL OF MATERIAL									
DECK** SCARIFICATION	CLASS I* SURFACE PREPARATION	CLASS II* SURFACE PREPARATION	CLASS III* SURFACE PREPARATION	HYDRO-DEMOLITION OF BRIDGE DECK	LATEX MODIFIED CONCRETE	PLACING & FINISHING LATEX MODIFIED CONCRETE	FOAM JOINT SEALS	GROOVING BRIDGE FLOORS	ASPHALT CONC. SURF. COURSE TYPE S9.5B
SO.YDS.	SO.YDS.	SO.YDS.	SO.YDS.	SO.YDS.	C.Y.	SO.YDS.	LUMP SUM	SO. FT.	TON
1,089	0	0	0	467	19.4	467	LUMP SUM	3,650	56

* QUANTITIES ARE SHOWN FOR INFORMATIONAL PURPOSES ONLY. IF ANY CLASS III LOCATIONS ARE ENCOUNTERED PRIOR TO OR DURING HYDRO-DEMOLITION, SEE TYP. "BLOW THRU" CONTAINMENT AND FALSEWORK DETAILS.
 ** INCLUDES MILLING OF ROADWAY PAVEMENT.

PROJECT NO. 17BP.1.P.3
 COUNTY: MARTIN
 DECK REPAIR BRIDGE NO. 28
 SHEET 1 OF 3

STATE OF NORTH CAROLINA
DEPARTMENT OF TRANSPORTATION
RALEIGH

PLAN OF BRIDGE AND BILL OF MATERIALS

28'-0" CLEAR ROADWAY (90°-00' SKEW)

REVISIONS				SHEET NO.
NO.	BY:	DATE:	NO.	DATE:
1			3	
2			4	



S-41
TOTAL SHEETS 50

DRAWN BY : K.H. COMPTON DATE : 10/11
 CHECKED BY : D. SNOKE DATE : 10/11

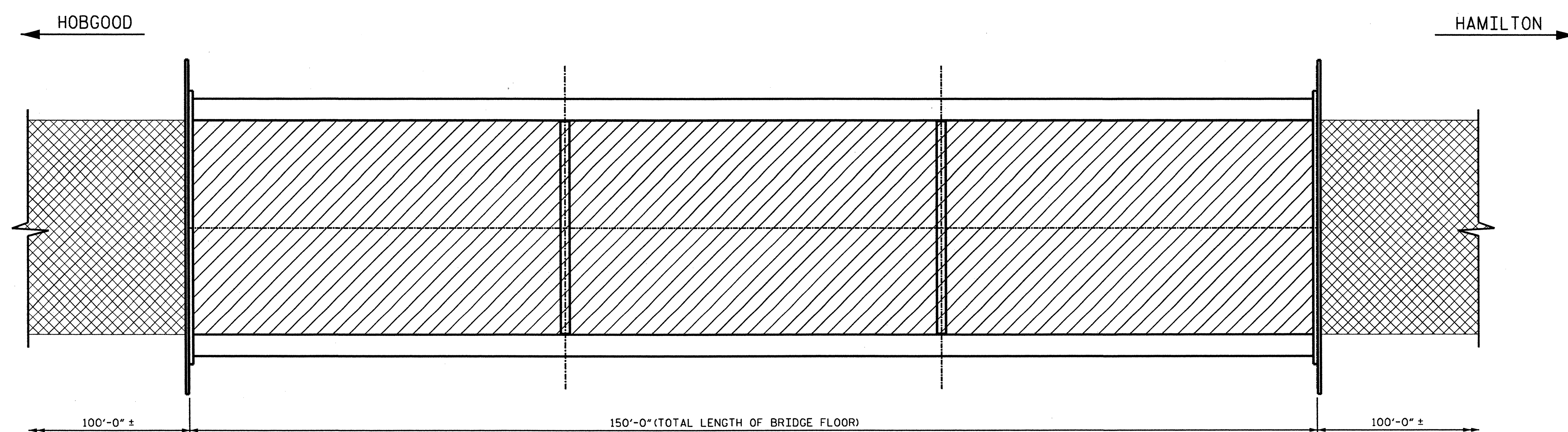
10-NOV-2011 10:10
 Z:\Squad\CDeck\Division 1\Proj01.dns\DKREHAB.570028.dgn
 gmuller

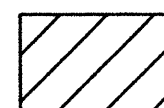

PLAN

-  DECK SCARIFICATION AND HYDRODEMOLITION
-  MILLING OF ROADWAY APPROACH

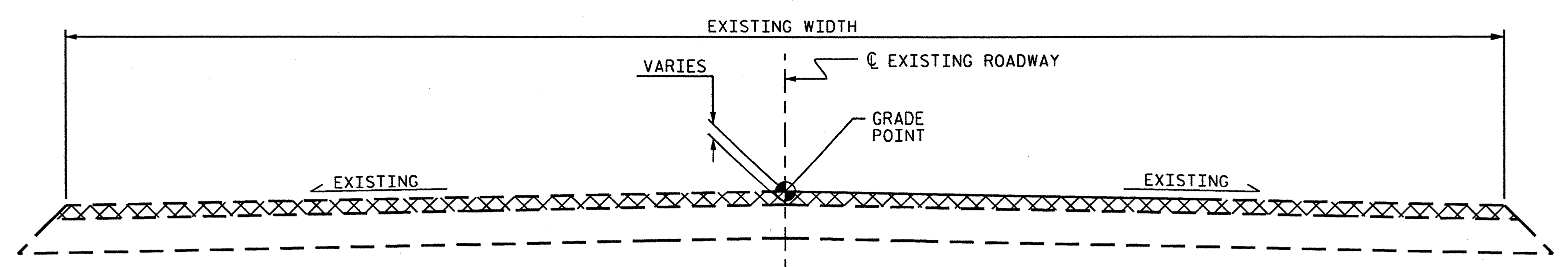

TYPICAL ROADWAY MILLING SECTION

C1 PROPOSED VARIABLE DEPTH ASPHALT CONCRETE SURFACE COURSE, TYPE SF 9.5B AT AN AVERAGE RATE OF 110 LBS. PER SQ. YD. PER 1" DEPTH, TO BE PLACED IN LAYERS NOT LESS THAN 1" IN DEPTH OR GREATER THAN 1 1/2" IN DEPTH.

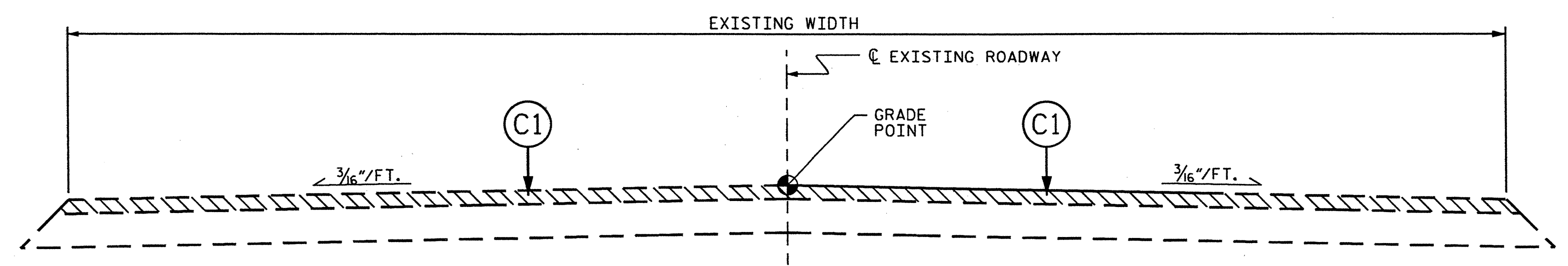

TYPICAL ROADWAY SECTION

PROJECT NO. 17BP.1.P.3
 COUNTY: MARTIN
 DECK REPAIR BRIDGE NO. 28
 SHEET 2 OF 3

STATE OF NORTH CAROLINA
 DEPARTMENT OF TRANSPORTATION
 RALEIGH

TYPICAL ROADWAY SECTION AND MILLING DETAILS

DRAWN BY : K.H. COMPTON DATE : 10/11
 CHECKED BY : D. SNOKE DATE : 10/11

NOT TO SCALE

REVISIONS						SHEET NO.
NO.	BY:	DATE:	NO.	BY:	DATE:	S-42
1			3			TOTAL SHEETS
2			4			50

10-NOV-2011 10:10
 Z:\Squad\C\Deck\Division 1\Proj01.dns\DKREHAB_570028.dgn
 dmuller

NOTES

EXISTING DECK DRAINS SHALL BE SEALED PRIOR TO BEGINNING REPAIR OF BRIDGE DECKS WITH LATEX MODIFIED CONCRETE. SEE SPECIAL PROVISIONS.

FOR HYDRO-DEMOLITION, SEE SPECIAL PROVISIONS.

THE CONTRACTOR MUST COLLECT, TREAT AND DISPOSE OF RUN-OFF WATER FROM THE HYDRO-DEMOLITION PROCESS. SEE SPECIAL PROVISIONS.

THE BOUNDARIES OF AREAS IDENTIFIED FOR CLASS III SURFACE PREPARATION ARE APPROXIMATE. THE CONTRACTOR SHALL PROVIDE A METHOD OF HANDLING UNEXPECTED BLOW THROUGH OF DECK. SEE DETAIL.

FOR OVERLAY OF BRIDGE DECKS WITH LATEX MODIFIED CONCRETE, SEE SPECIAL PROVISIONS.

SEE SPECIAL PROVISIONS FOR SURFACE PREPARATION.

EXISTING BRIDGE INFORMATION BASED ON BEST AVAILABLE DATA.

FOR FOAM JOINT SEAL SEE SPECIAL PROVISIONS.

THE INSTALLED FOAM JOINT SEAL SHALL BE WATER TIGHT.

NOMINAL UNCOMPRESSED SEAL WIDTH OF FOAM JOINT SEAL SHALL BE 2 1/2" AT BENTS.

THE CONTRACTOR WILL NOT BE PERMITTED TO FORM THE JOINT FOR THE FOAM JOINT SEAL IN LIEU OF SAWING THE JOINT

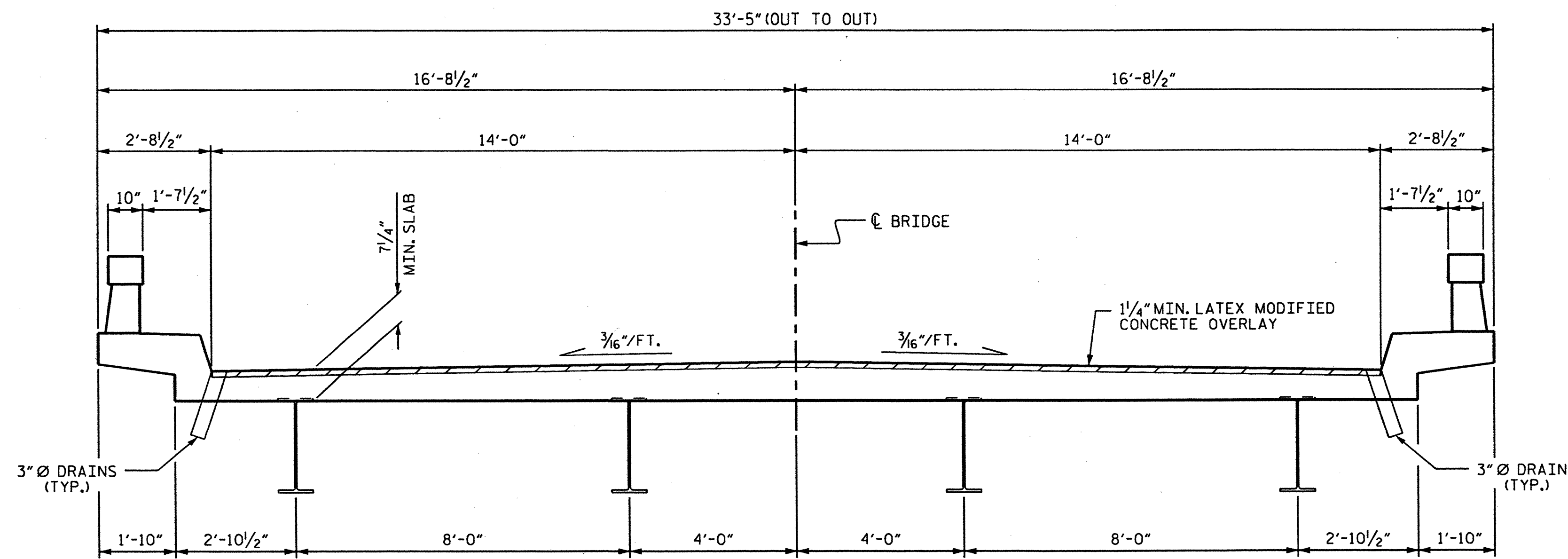

TYPICAL SECTION

ELASTOMERIC CONCRETE	
BENTS	10.7 (CU. FT.)
END BENTS	0 (CU. FT.)
* TOTAL	10.7 (CU. FT.)

* BASED ON THE MINIMUM BLOCKOUT SHOWN.

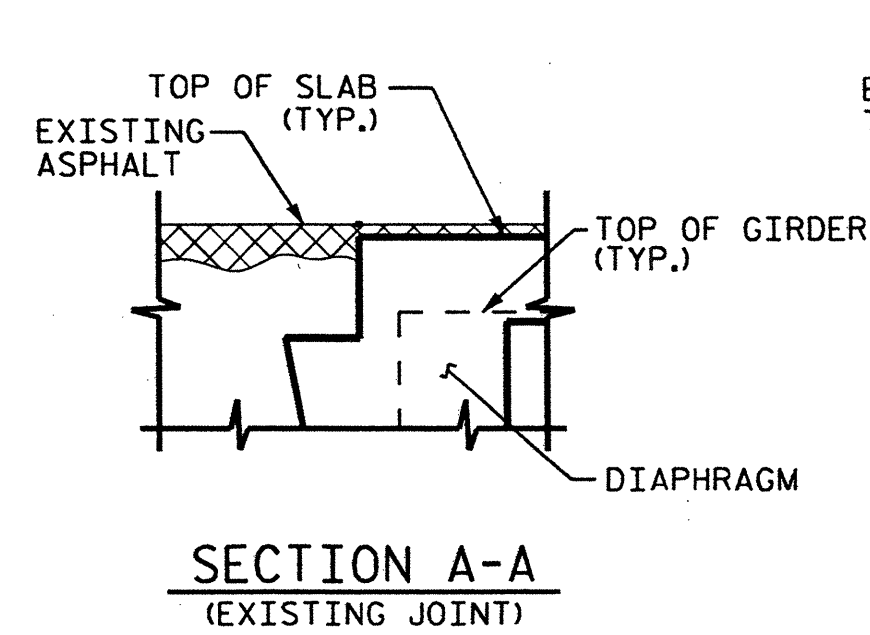

SECTION A-A
(EXISTING JOINT)

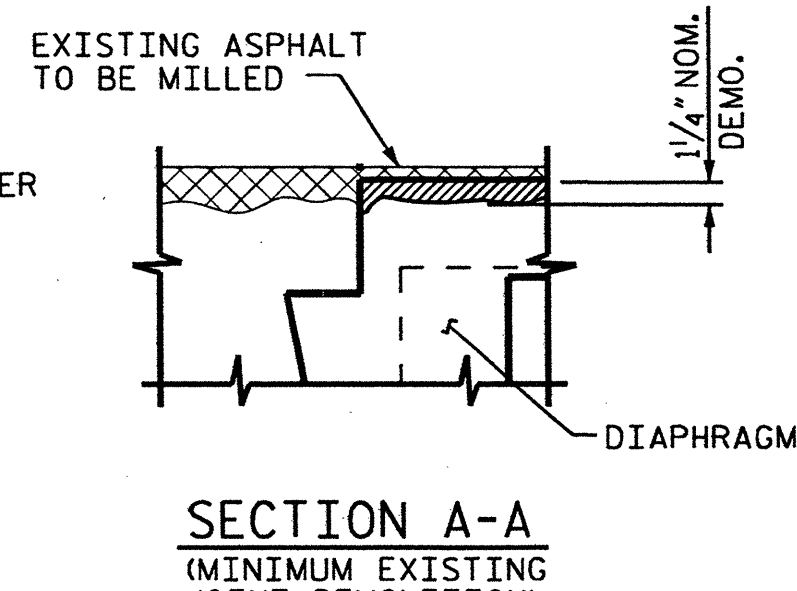

SECTION A-A
(MINIMUM EXISTING JOINT DEMOLITION)

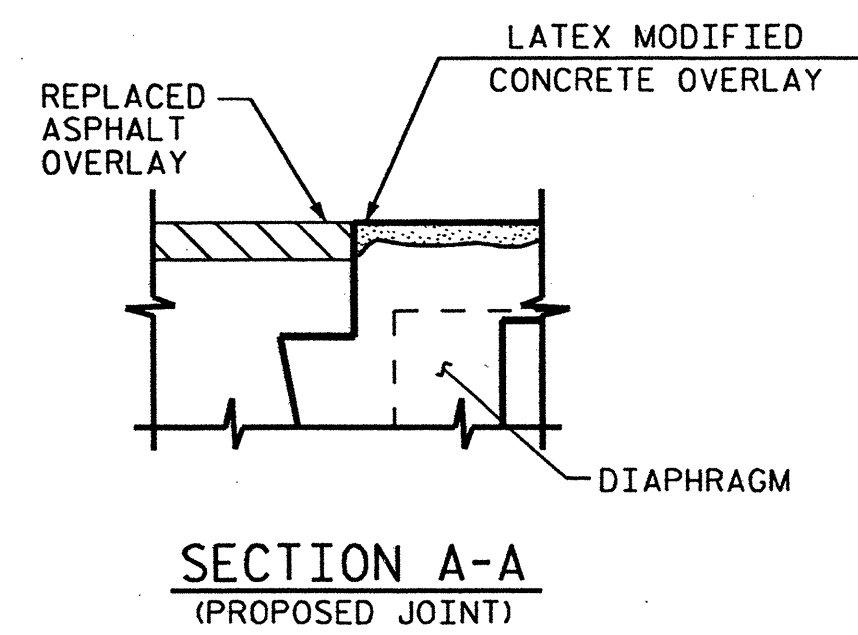

SECTION A-A
(PROPOSED JOINT)

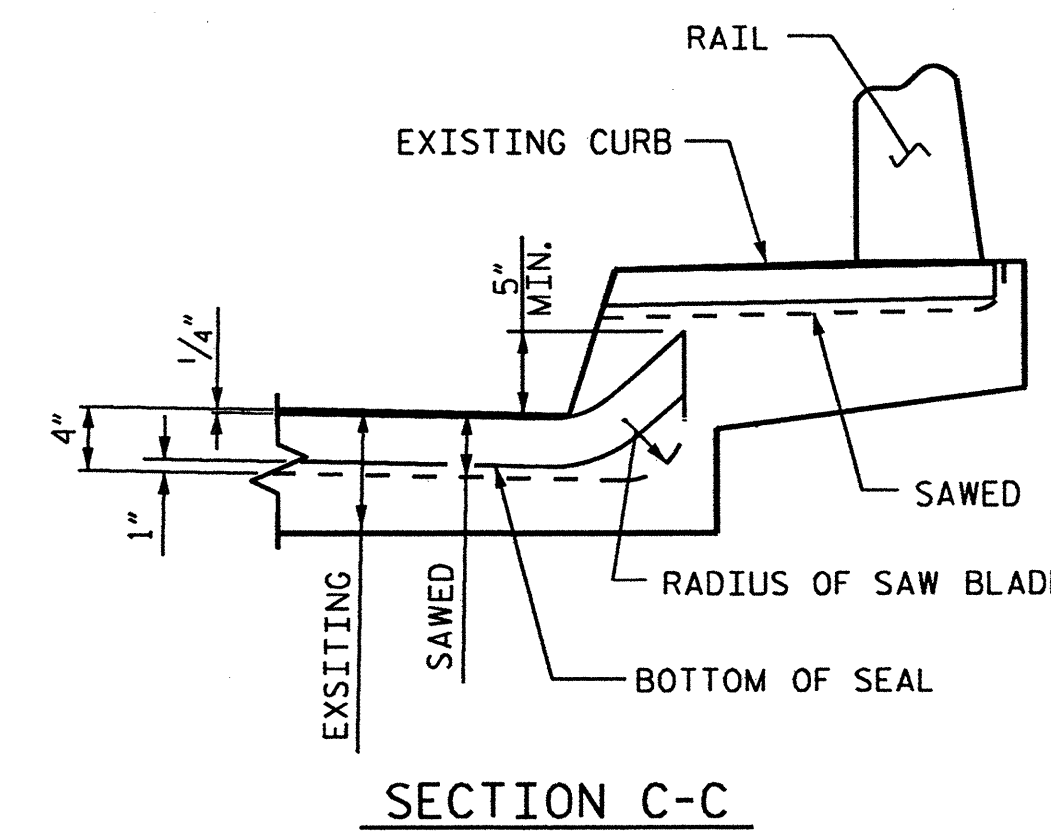

SECTION C-C

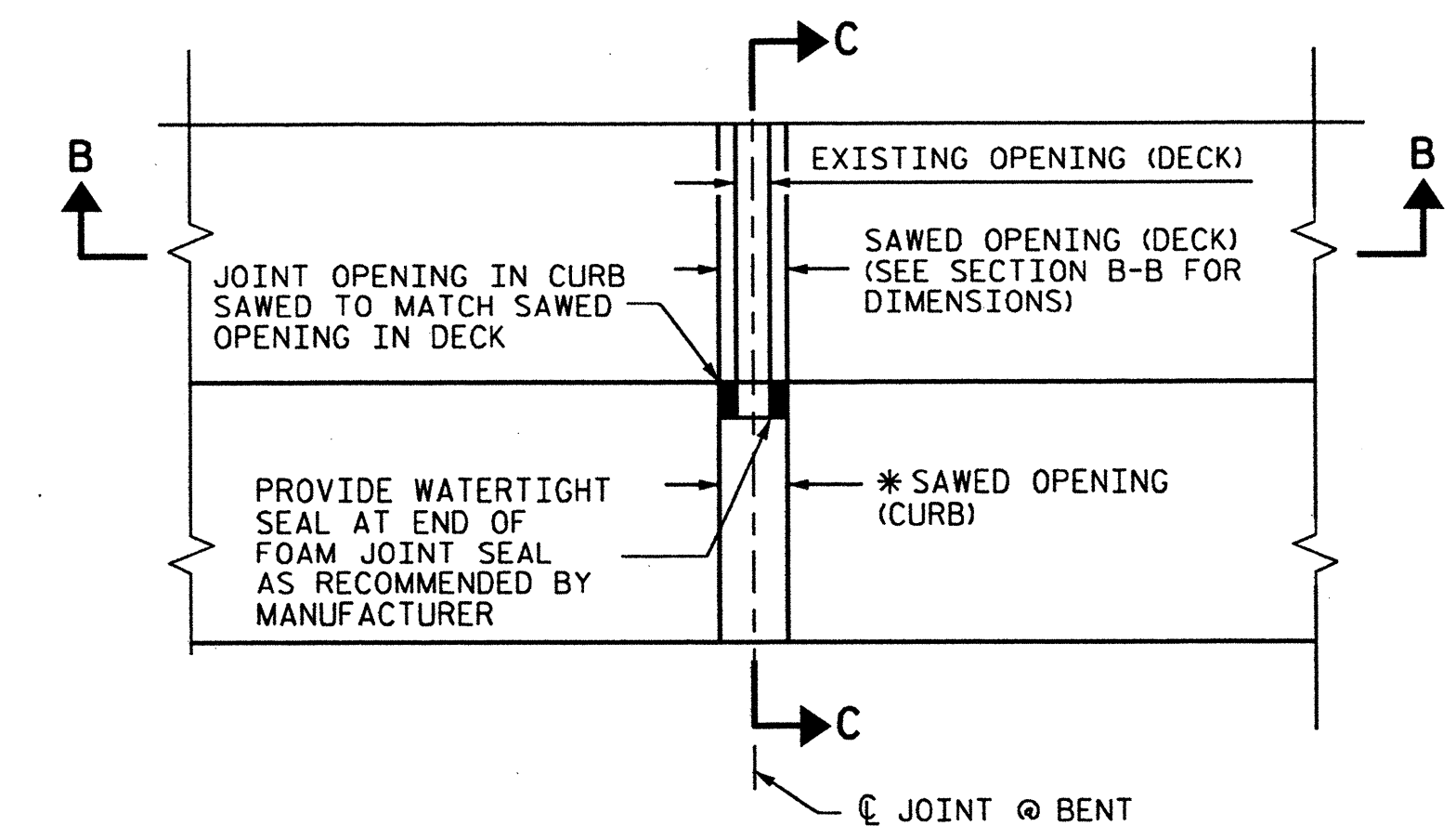

FOAM JOINT SEAL DETAILS

* SEAL WIDTH IN CURB TO BE DETERMINED BY THE ENGINEER

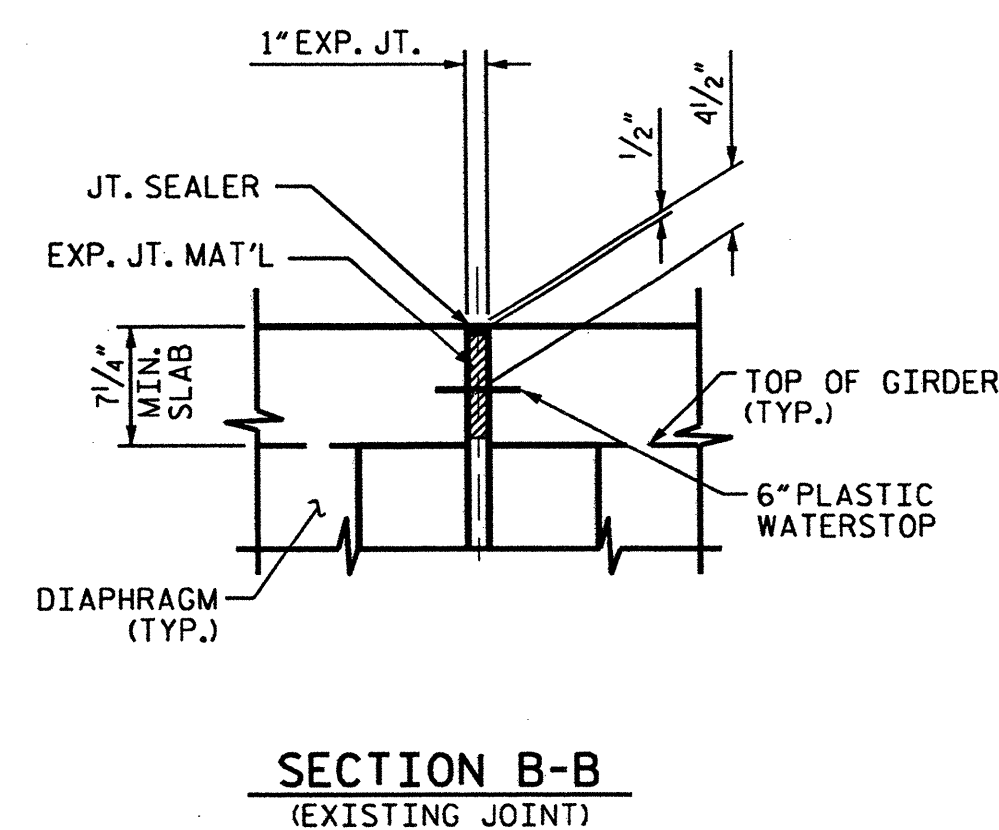

SECTION B-B
(EXISTING JOINT)

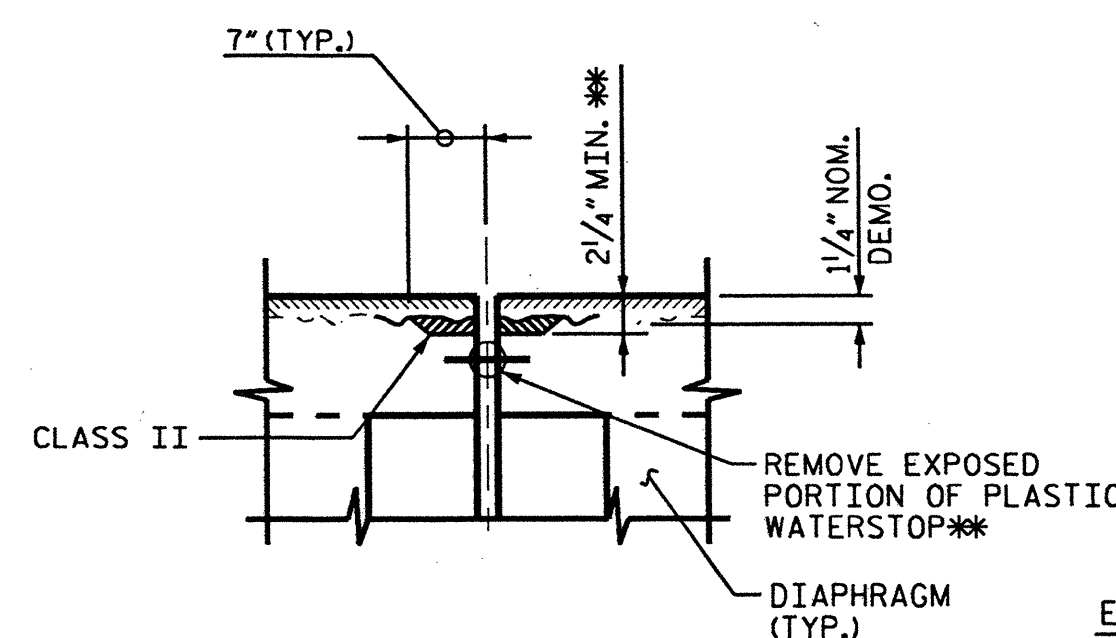

SECTION B-B
(MINIMUM EXISTING JOINT DEMOLITION)

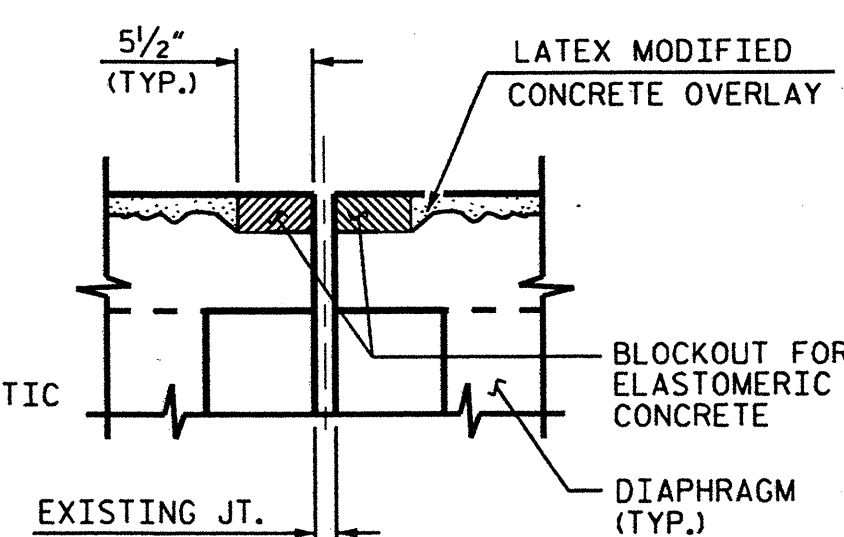

SECTION B-B
(PROPOSED EVAZOTE JOINT SEAL PRE-SAWED DIMENSIONS)

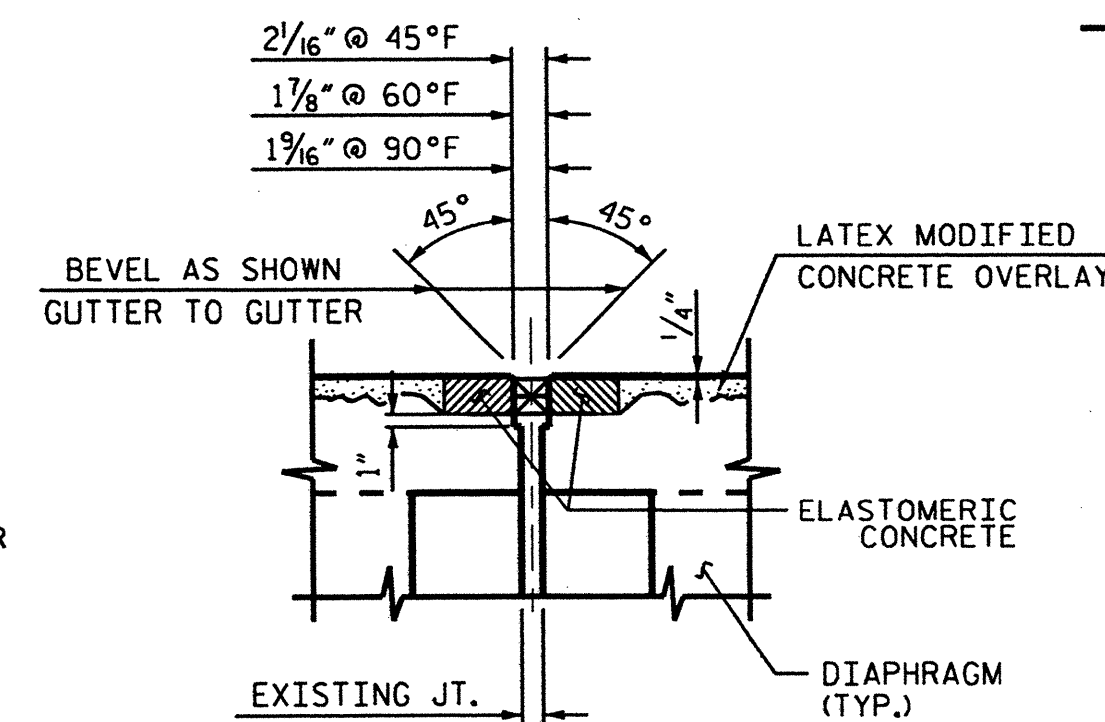

SECTION B-B
(PROPOSED EVAZOTE JOINT SEAL EXPANSION)

** ALL LOOSE AND UNSOUND CONCRETE SHALL BE REMOVED. IF THE EMBEDDED PORTION OF THE EXISTING PLASTIC WATERSTOP IS EXPOSED DURING REMOVAL OF UNSOUND CONCRETE, THE ENTIRE WATERSTOP SHALL BE REMOVED.

PROJECT NO. 17BP.1.P.3
 COUNTY: MARTIN
 DECK REPAIR BRIDGE NO. 28
 SHEET 3 OF 3

REVISIONS						SHEET NO.
NO.	BY:	DATE:	NO.	BY:	DATE:	S-43
1			3			TOTAL SHEETS
2			4			50

DRAWN BY : K.H. COMPTON DATE : 10/11
 CHECKED BY : D. SNOKE DATE : 10/11

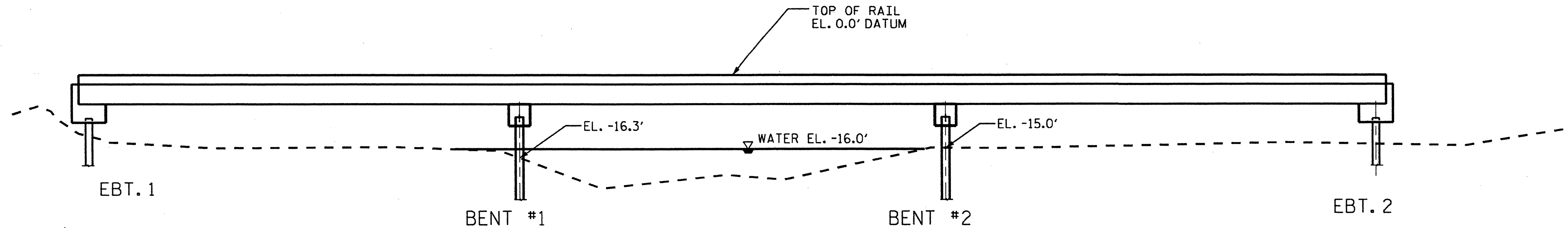

PROFILE OF BRIDGE

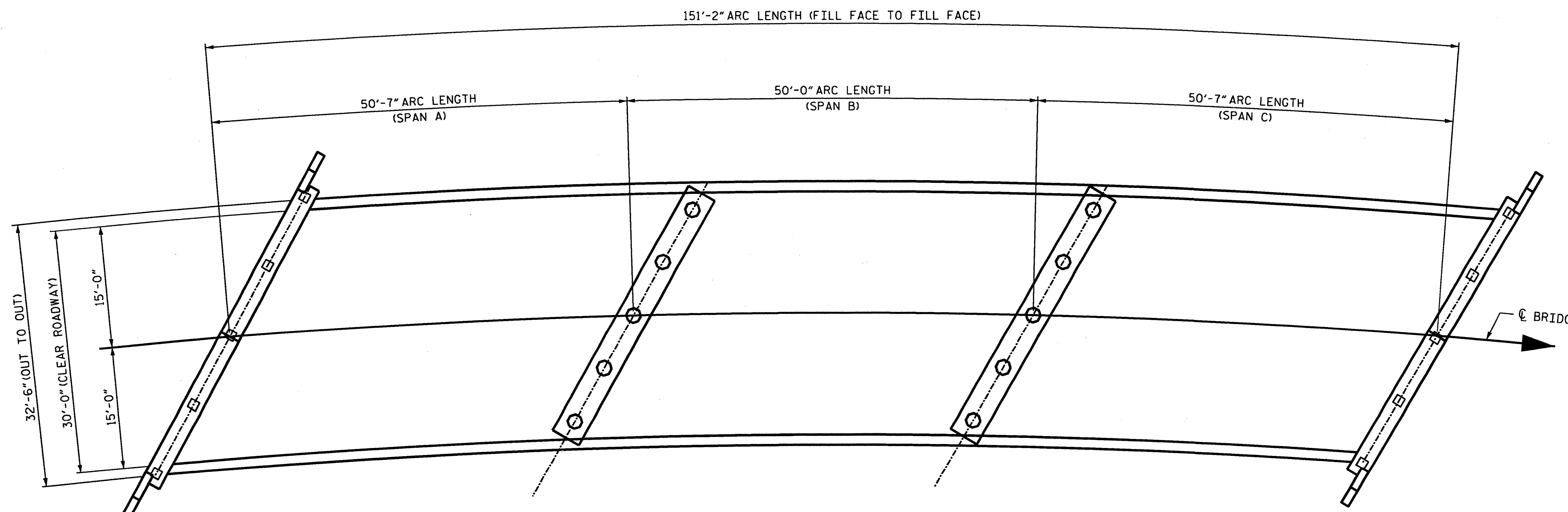

PLAN OF BRIDGE

TOTAL BILL OF MATERIAL

DECK ** SCARIFICATION	CLASS I* SURFACE PREPARATION	CLASS II* SURFACE PREPARATION	CLASS III* SURFACE PREPARATION	HYDRO-DEMOLITION OF BRIDGE DECK	LATEX MODIFIED CONCRETE	PLACING & FINISHING LATEX MODIFIED CONCRETE	FOAM JOINT SEALS	GROOVING BRIDGE FLOORS	ASPHALT CONC. SURF. COURSE TYPE S9.5B	PILE ENCAPSULATION
SO.YDS.	SO.YDS.	SO.YDS.	SO.YDS.	SO.YDS.	C.Y.	SO.YDS.	LUMP SUM	SO. FT.	TON	LF
729	0	0	0	504	17.5	504	LUMP SUM	3,880	20	39

* QUANTITIES ARE SHOWN FOR INFORMATIONAL PURPOSES ONLY. IF ANY CLASS III LOCATIONS ARE ENCOUNTERED PRIOR TO OR DURING HYDRO-DEMOLITION, SEE TYP. "BLOW THRU" CONTAINMENT AND FALSEWORK DETAILS.

** INCLUDES MILLING OF ROADWAY PAVEMENT.

PROJECT NO. 17BP.1.P.3

COUNTY: MARTIN

DECK REPAIR BRIDGE NO. 42

SHEET 1 OF 7

STATE OF NORTH CAROLINA
DEPARTMENT OF TRANSPORTATION
RALEIGH



GENERAL DRAWING
BRIDGE #42 ON SR1528
OVER HARDISON MILL CRK.

REVISIONS						SHEET NO.
NO.	BY:	DATE:	NO.	BY:	DATE:	S-44
1			3			TOTAL SHEETS
2			4			50

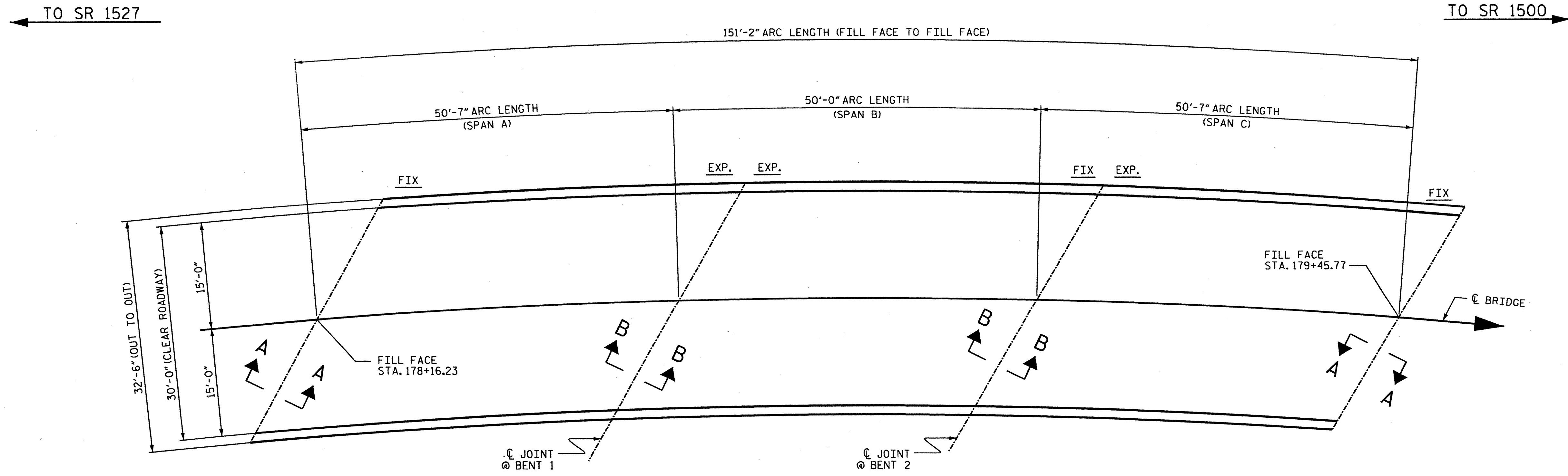
DRAWN BY : K.H. COMPTON DATE : 10/11
CHECKED BY : D. SNOKE DATE : 10/11



PLAN OF SPANS- DECK REPAIRS

 APPROX. AREA: CLASS II REPAIR
 APPROX. AREA: CLASS III REPAIR

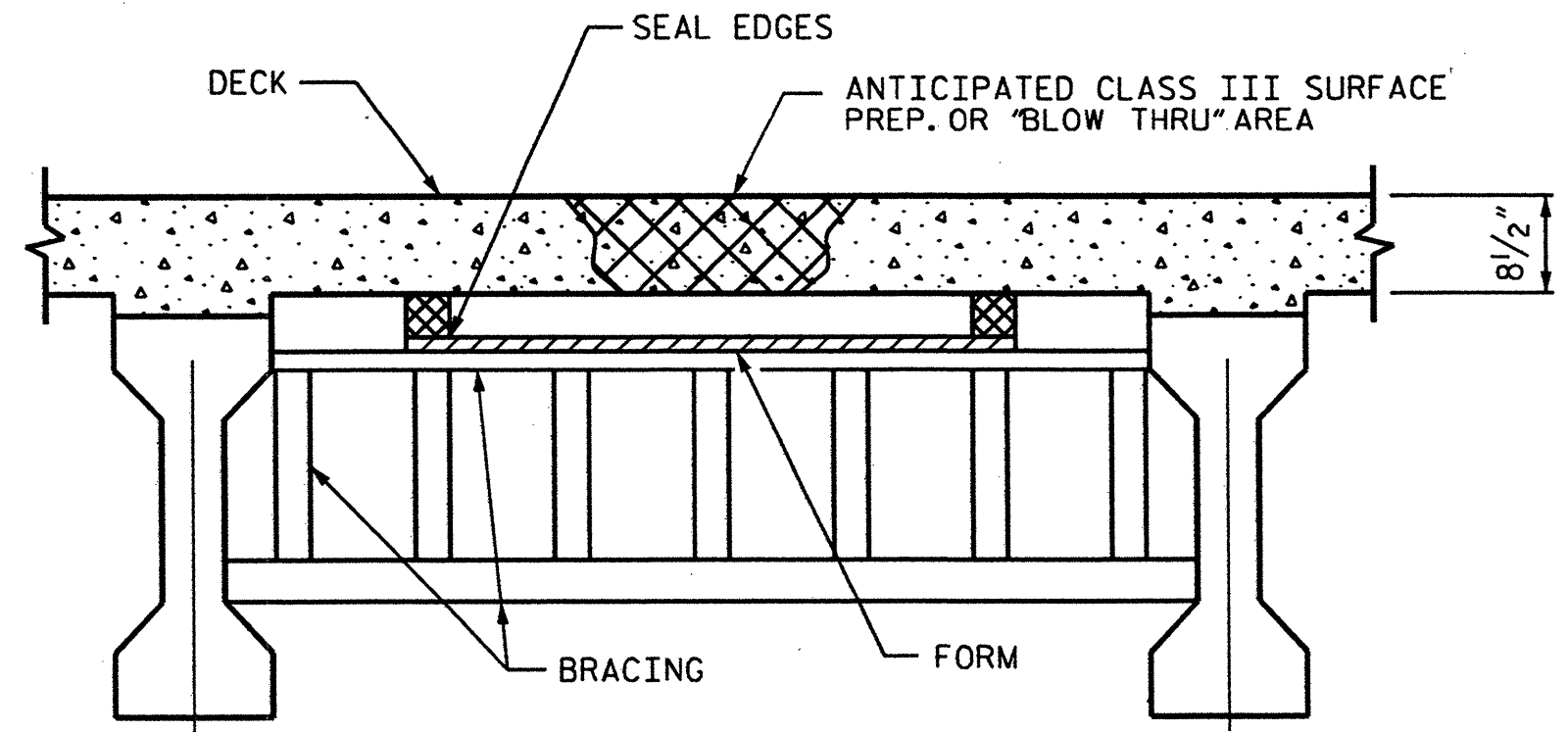

TYP. "BLOW THRU" CONTAINMENT AND FORMWORK

A METHOD TO CAPTURE WATER AND DEBRIS FROM BLOW THRU DURING HYDRO-DEMOLITION SHALL BE INSTALLED IN AREAS INDICATED AS CLASS III SURFACE PREPARATION.
 SUBMIT DETAILS OF PROPOSED FORMWORK FOR APPROVAL PRIOR TO BEGINNING WORK.
 COST FOR INSTALLING AND REMOVING FORMWORK SHALL BE INCIDENTAL TO THE PRICE PER SQ. YARD OF HYDRO-DEMOLITION.

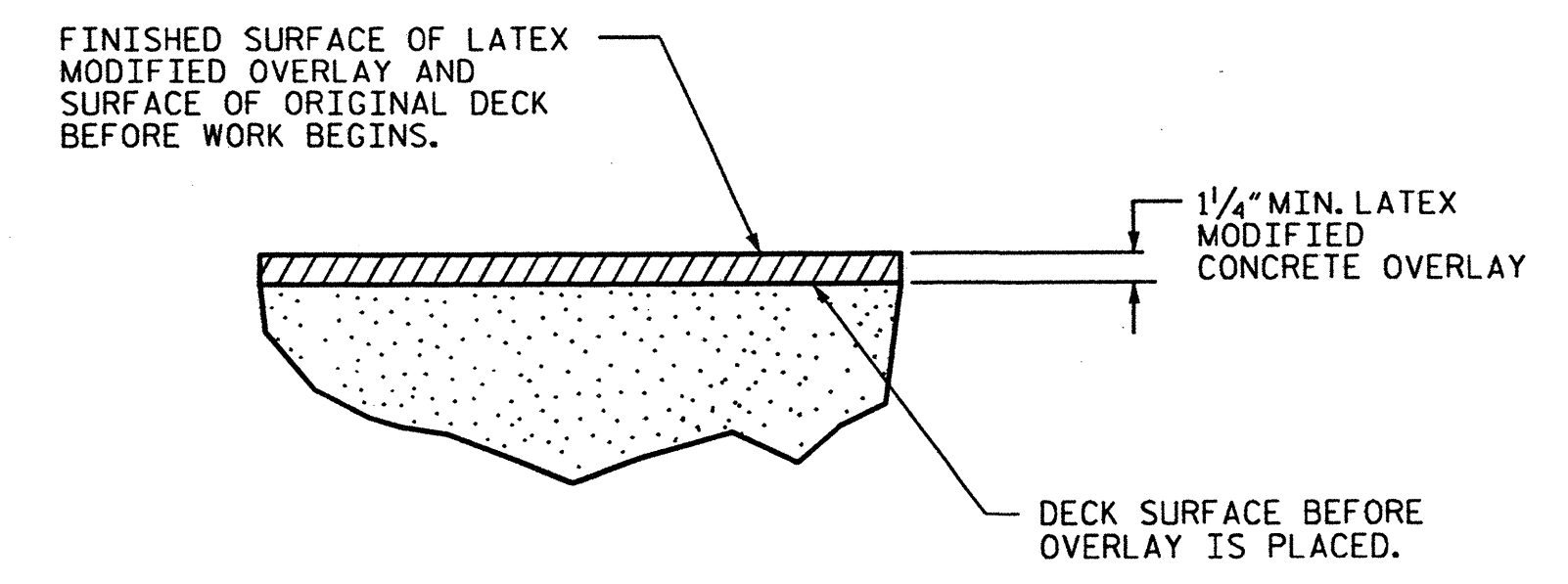

DETAIL FOR LATEX MODIFIED CONCRETE OVERLAY

PROJECT NO. 17BP.1.P.3
 COUNTY: MARTIN
 DECK REPAIR BRIDGE NO. 42
 SHEET 2 OF 7

STATE OF NORTH CAROLINA
 DEPARTMENT OF TRANSPORTATION
 RALEIGH

PLAN OF BRIDGE



DRAWN BY : K.H. COMPTON DATE : 9/11
 CHECKED BY : D. SNOKE DATE : 9/11

REVISIONS						SHEET NO. S-45
NO.	BY:	DATE:	NO.	BY:	DATE:	
1			3			TOTAL SHEETS 50
2			4			

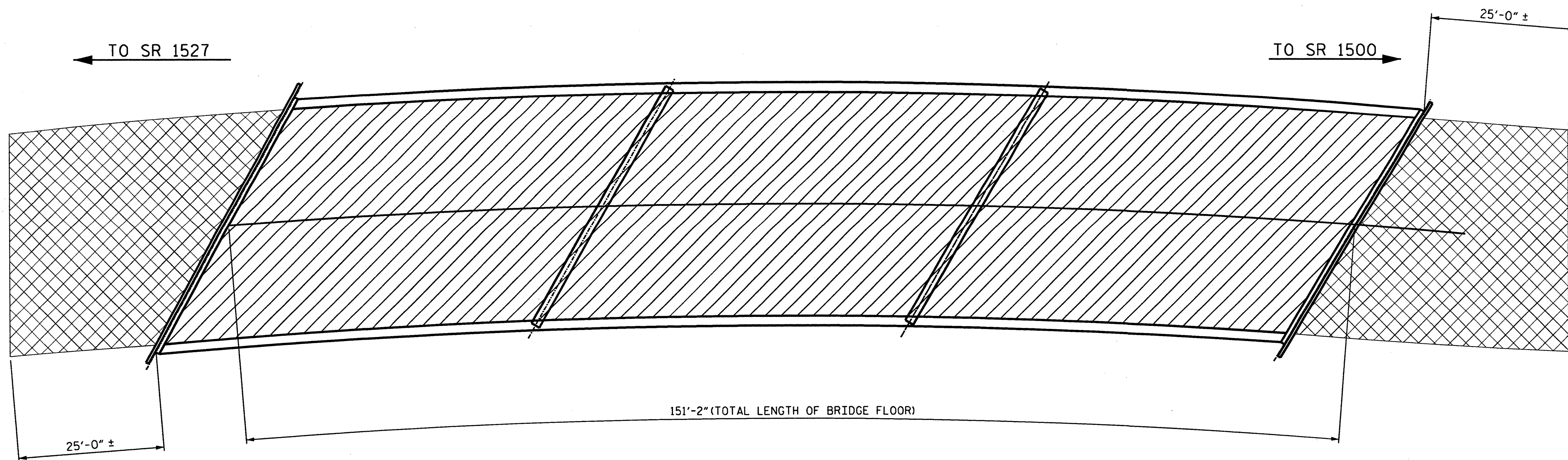
10-NOV-2011 10:10
 Z:\Squad\CDeck\Division 1\Proj01.dns\DKREHAB_570042.dgn
 dmuller

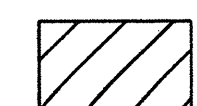

PLAN

-  DECK SCARIFICATION AND HYDRODEMOLITION
-  MILLING OF ROADWAY APPROACH

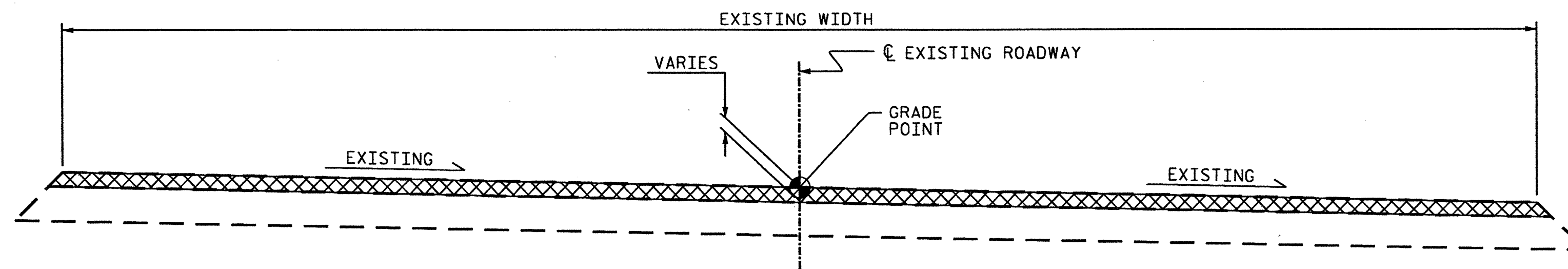

TYPICAL ROADWAY MILLING SECTION

C1 PROPOSED VARIABLE DEPTH ASPHALT CONCRETE SURFACE COURSE, TYPE SF 9.5B AT AN AVERAGE RATE OF 110 LBS. PER SQ. YD. PER 1" DEPTH, TO BE PLACED IN LAYERS NOT LESS THAN 1" IN DEPTH OR GREATER THAN 1 1/2" IN DEPTH.

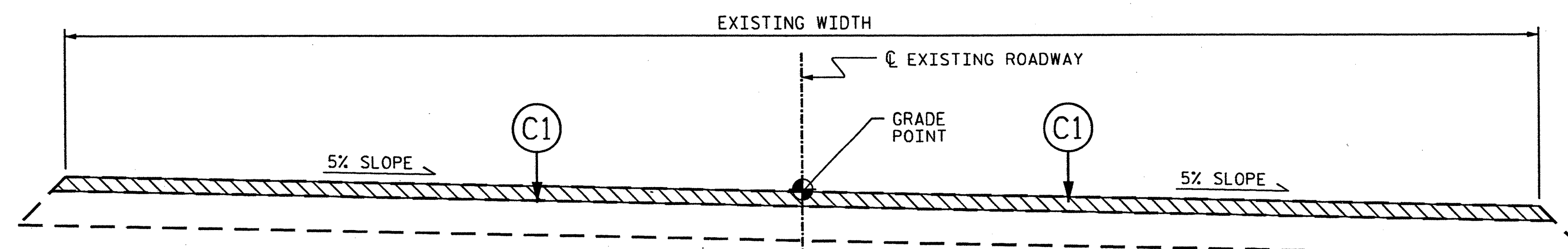

TYPICAL ROADWAY SECTION

PROJECT NO. 17BP.1.P.3
 COUNTY: MARTIN
 DECK REPAIR BRIDGE NO. 42
 SHEET 3 OF 7

STATE OF NORTH CAROLINA
 DEPARTMENT OF TRANSPORTATION
 RALEIGH

TYPICAL ROADWAY
 SECTION AND
 MILLING DETAILS

REVISIONS						SHEET NO.
NO.	BY:	DATE:	NO.	BY:	DATE:	S-46
1			3			TOTAL SHEETS
2			4			50

DRAWN BY : K.H. COMPTON DATE : 10/11
 CHECKED BY : D. SNOKE DATE : 9/11

NOT TO SCALE

10-NOV-2011 10:10
 Z:\Squad C\Deck\Division 1\Proj01.dhs\DKREHAB.570042.dgn
 dmiller

NOTES

EXISTING DECK DRAINS SHALL BE SEALED PRIOR TO BEGINNING REPAIR OF BRIDGE DECKS WITH LATEX MODIFIED CONCRETE. SEE SPECIAL PROVISIONS.

FOR HYDRO-DEMOLITION, SEE SPECIAL PROVISIONS.

THE CONTRACTOR MUST COLLECT, TREAT AND DISPOSE OF RUN-OFF WATER FROM THE HYDRO-DEMOLITION PROCESS, SEE SPECIAL PROVISIONS.

THE BOUNDARIES OF AREAS IDENTIFIED FOR CLASS III SURFACE PREPARATION ARE APPROXIMATE. THE CONTRACTOR SHALL PROVIDE A METHOD OF HANDLING UNEXPECTED BLOW THROUGH OF DECK. SEE DETAIL.

FOR OVERLAY OF BRIDGE DECKS WITH LATEX MODIFIED CONCRETE, SEE SPECIAL PROVISIONS.

SEE SPECIAL PROVISIONS FOR SURFACE PREPARATION.

EXISTING BRIDGE INFORMATION BASED ON BEST AVAILABLE DATA.

FOR FOAM JOINT SEAL SEE SPECIAL PROVISIONS.

THE INSTALLED FOAM JOINT SEAL SHALL BE WATER TIGHT.

NOMINAL UNCOMPRESSED SEAL WIDTH OF FOAM JOINT SEAL SHALL BE 2 1/2" AT BENTS.

THE CONTRACTOR WILL NOT BE PERMITTED TO FORM THE JOINT FOR THE FOAM JOINT SEAL IN LIEU OF SAWING THE JOINT

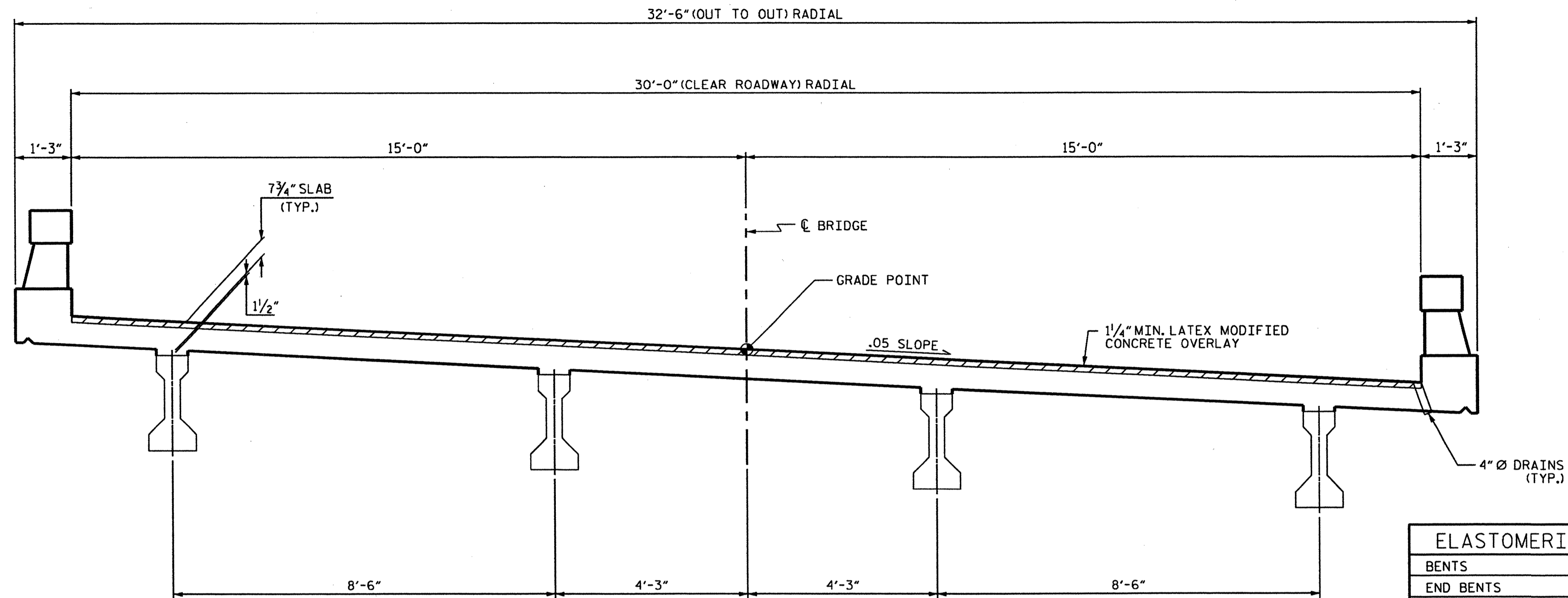

ELASTOMERIC CONCRETE	
BENTS	13.2 (CU. FT.)
END BENTS	0 (CU. FT.)
* TOTAL	13.2 (CU. FT.)

* BASED ON THE MINIMUM BLOCKOUT SHOWN.

TYPICAL SECTION

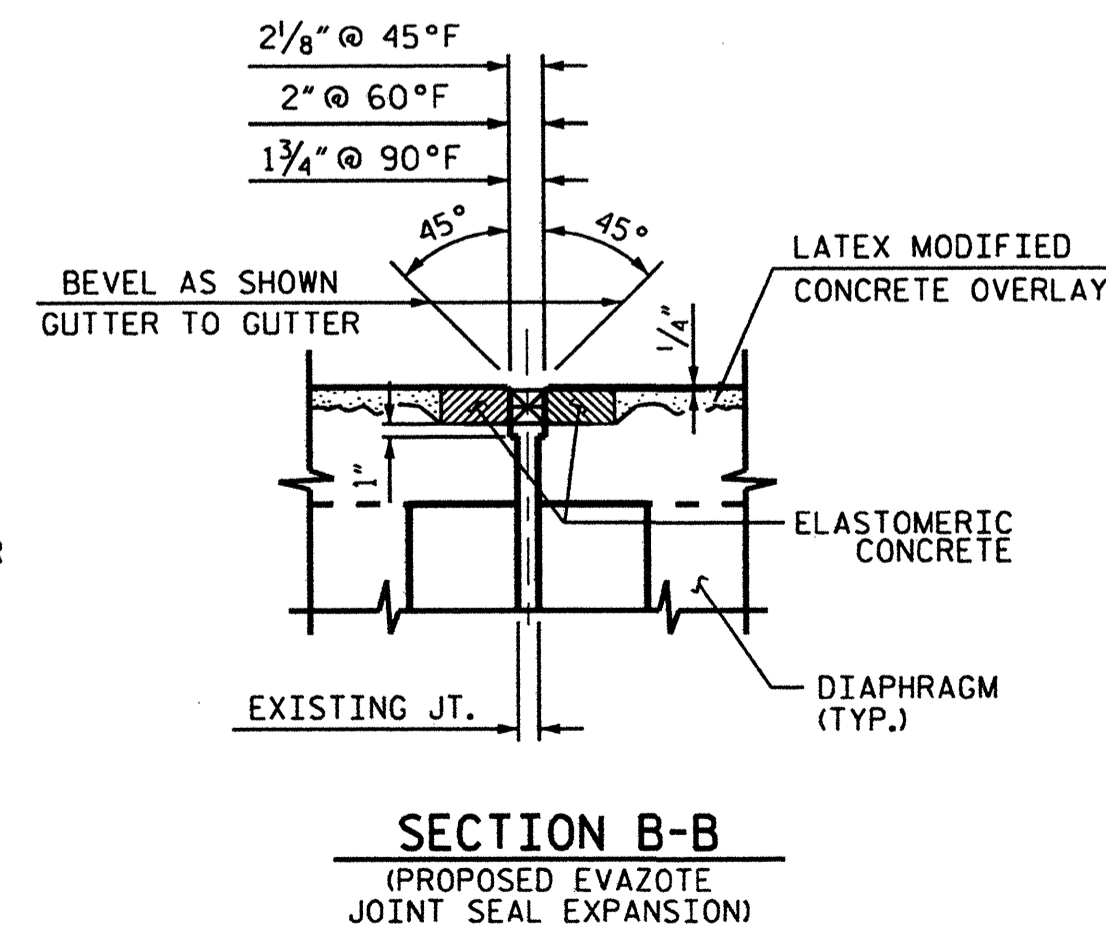
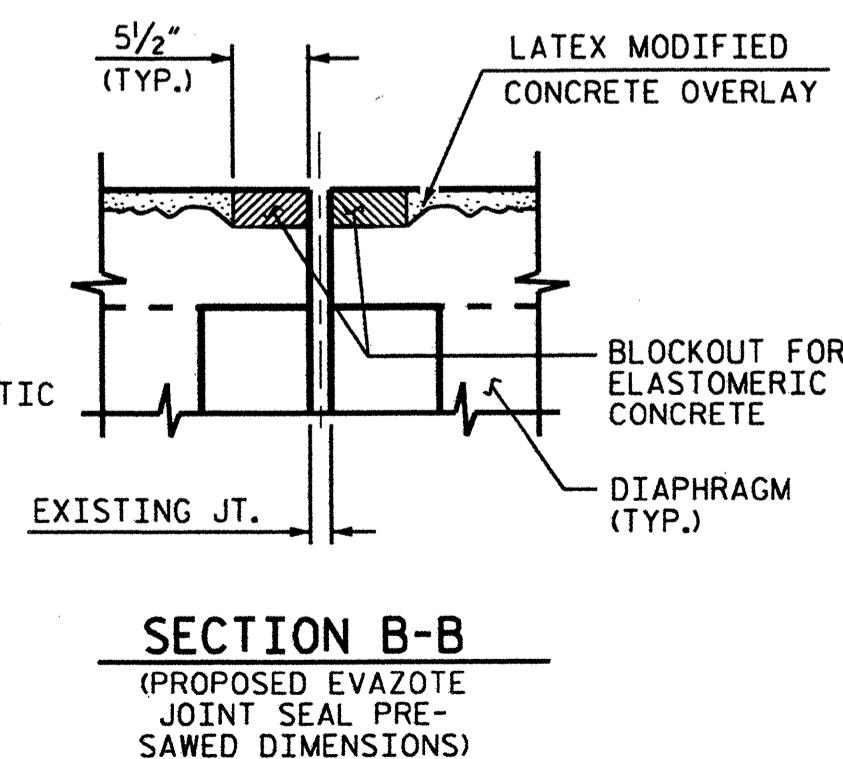
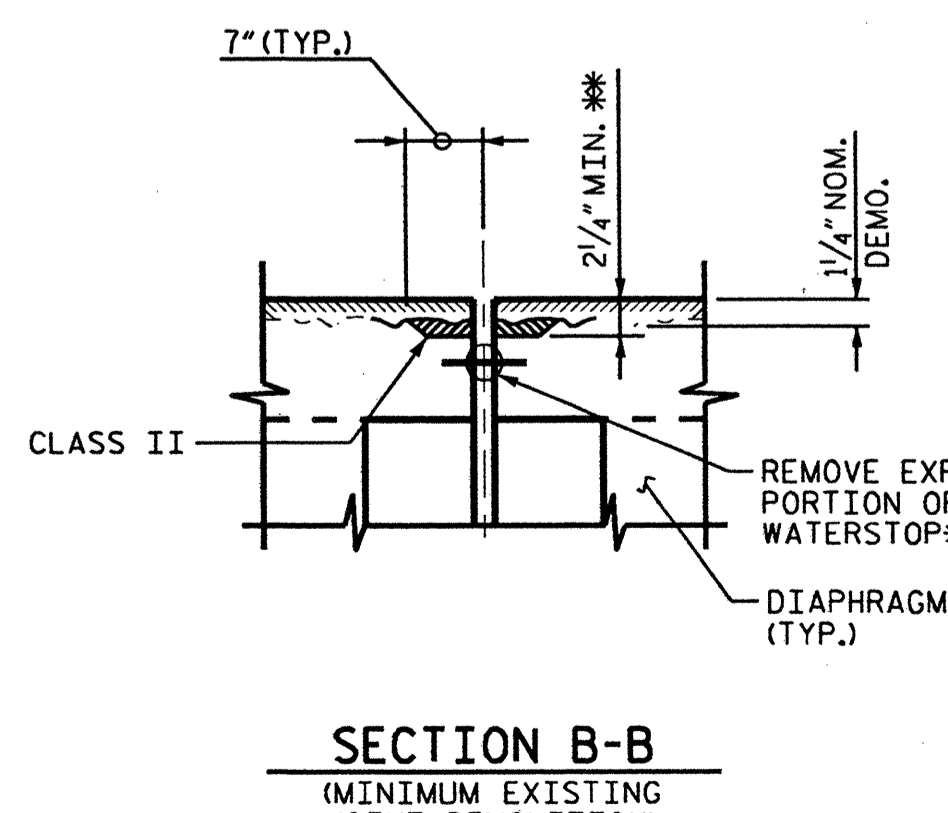
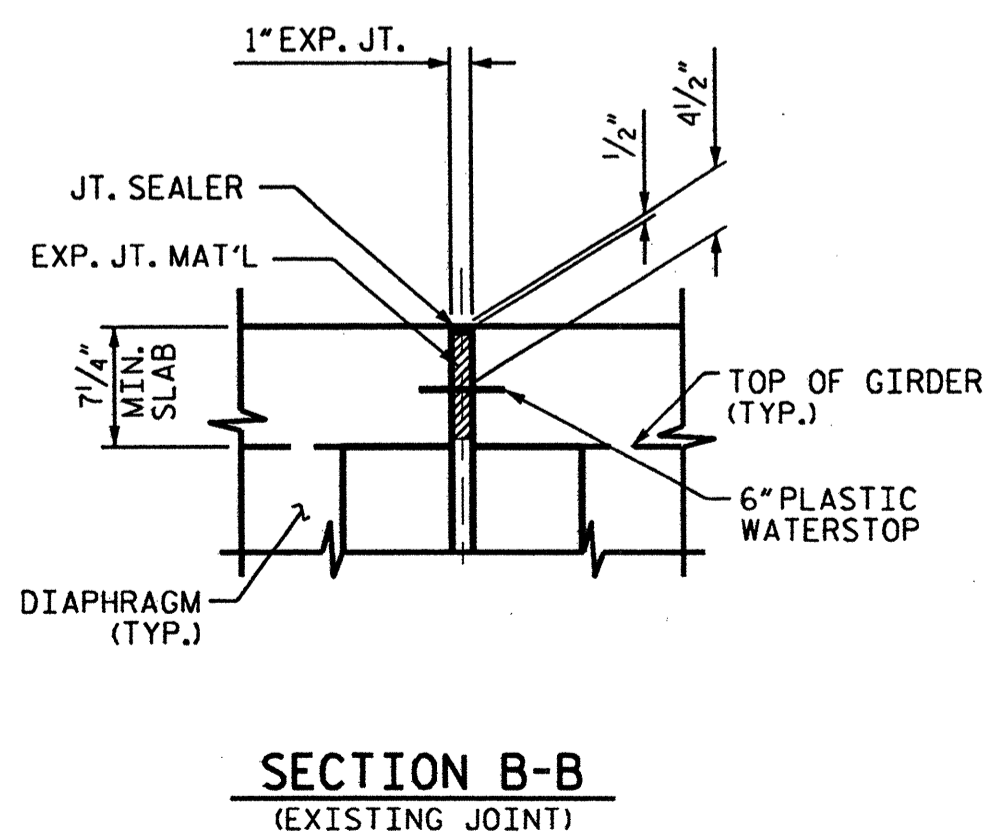
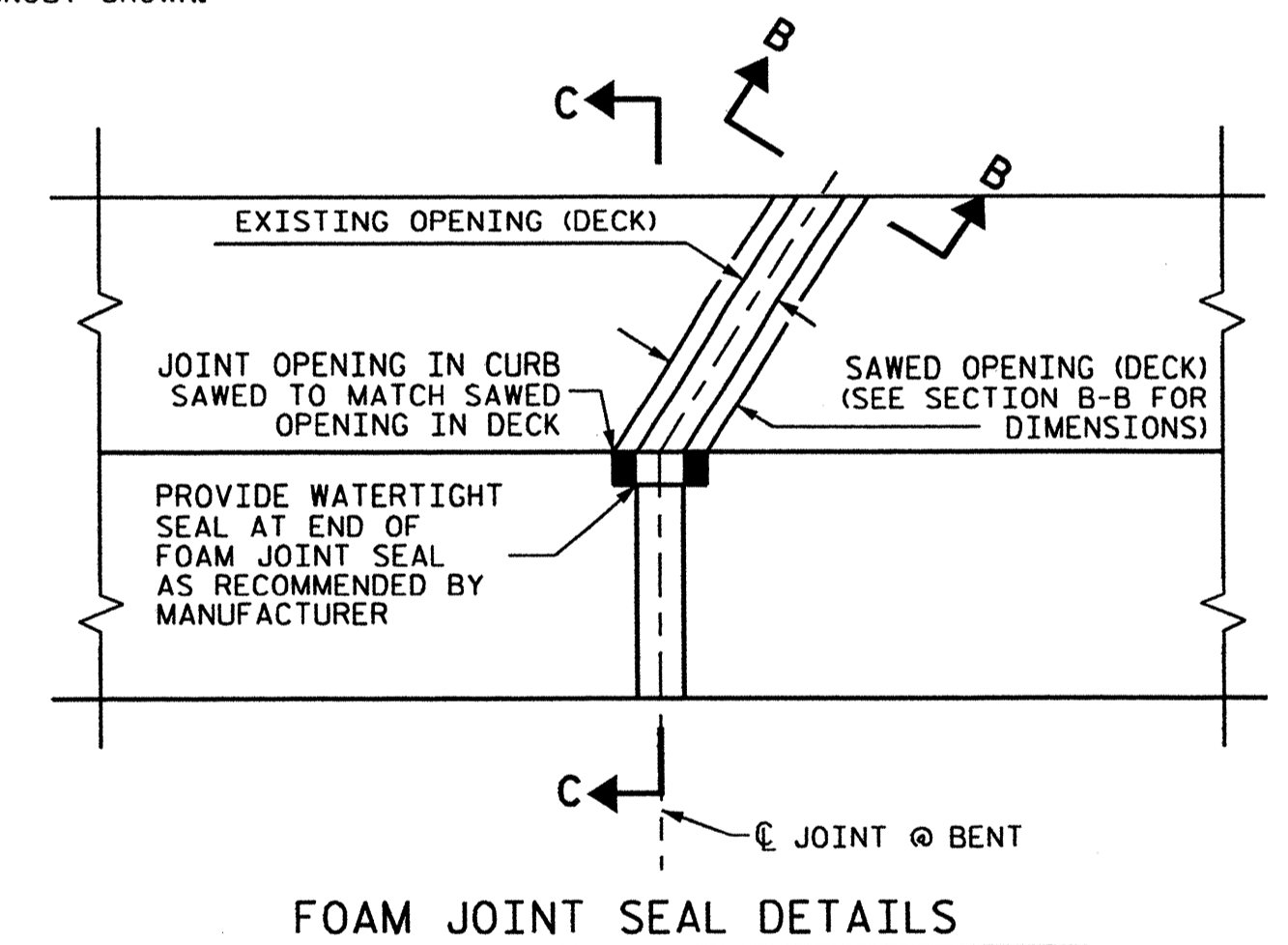
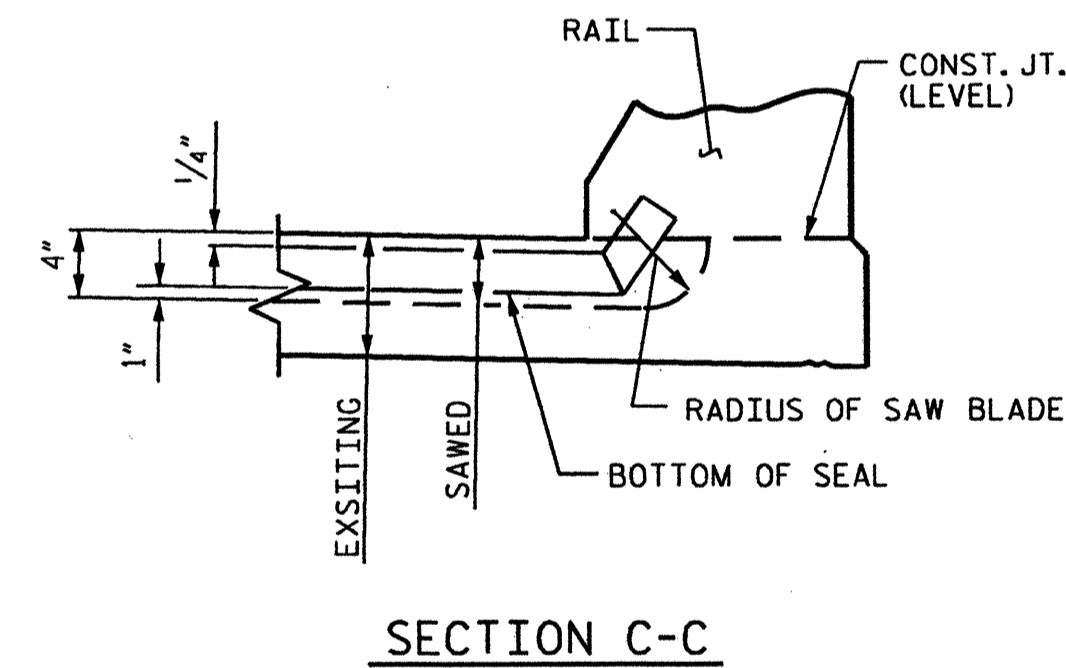
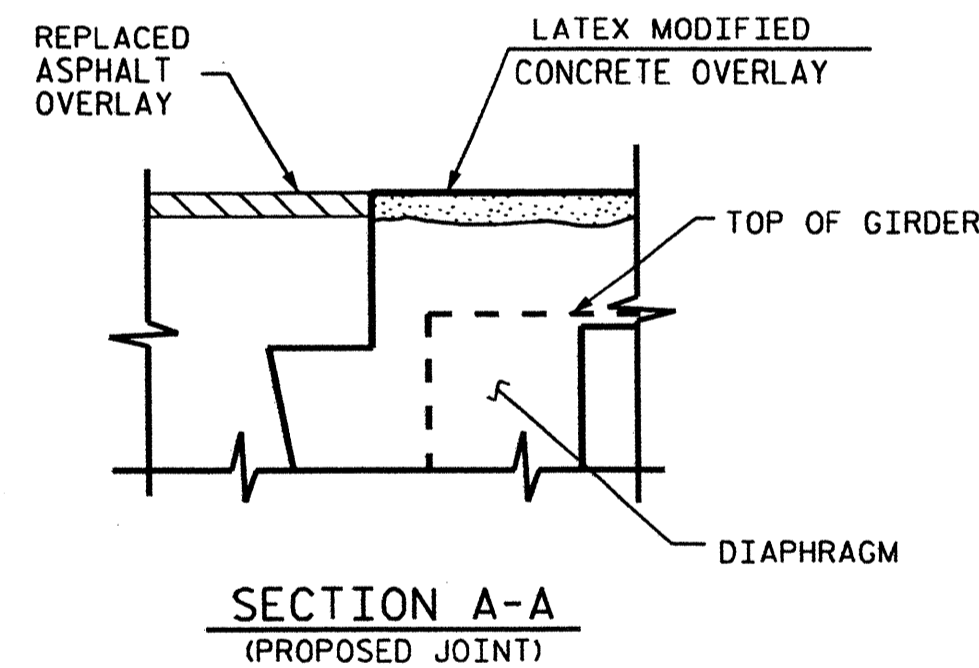
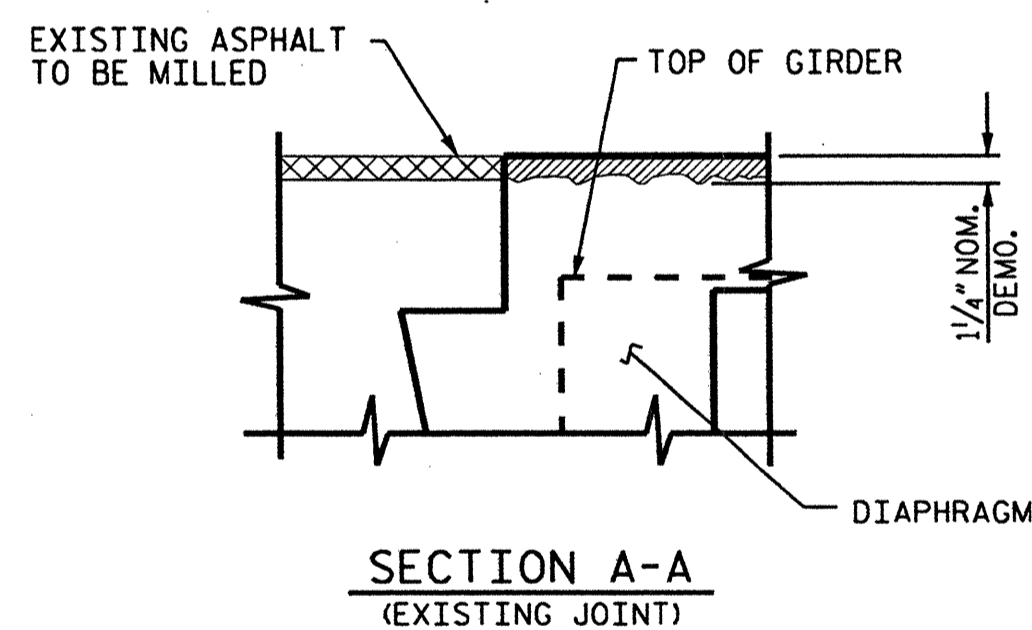

* ALL LOOSE AND UNSOUND CONCRETE SHALL BE REMOVED. IF THE EMBEDDED PORTION OF THE EXISTING PLASTIC WATERSTOP IS EXPOSED DURING REMOVAL OF UNSOUND CONCRETE, THE ENTIRE WATERSTOP SHALL BE REMOVED.

PROJECT NO. 17BP.1.P.3
 COUNTY: MARTIN
 DECK REPAIR BRIDGE NO. 42
 SHEET 4 OF 7

STATE OF NORTH CAROLINA
 DEPARTMENT OF TRANSPORTATION
 RALEIGH

TYPICAL SECTION AND JOINT DETAILS

REVISIONS						SHEET NO.
NO.	BY:	DATE:	NO.	BY:	DATE:	S-47
1			3			TOTAL SHEETS
2			4			50

DRAWN BY : K.H. COMPTON DATE : 10/11
 CHECKED BY : D. SNOKE DATE : 10/11

NOTES

1. FOR EXAMPLES OF TYPICAL ENCAPSULATION OF PILES SEE SHEETS #49 AND #50.
2. REPAIR OF THE BRIDGE SHALL BE PERFORMED SO AS NOT TO ALLOW DEBRIS TO FALL INTO THE WATER.

PILE ENCAPSULATION LOCATIONS

BENT	PILE	LF
1	ALL	23
2	ALL	16
TOTAL	10	39

PILE ENCAPSULATION LENGTHS INCLUDE 1'-0" ABOVE DAMAGED AREA AND 1'-0" BELOW MUD LINE.

QUANTITIES ARE BASED ON BEST AVAILABLE INFORMATION.

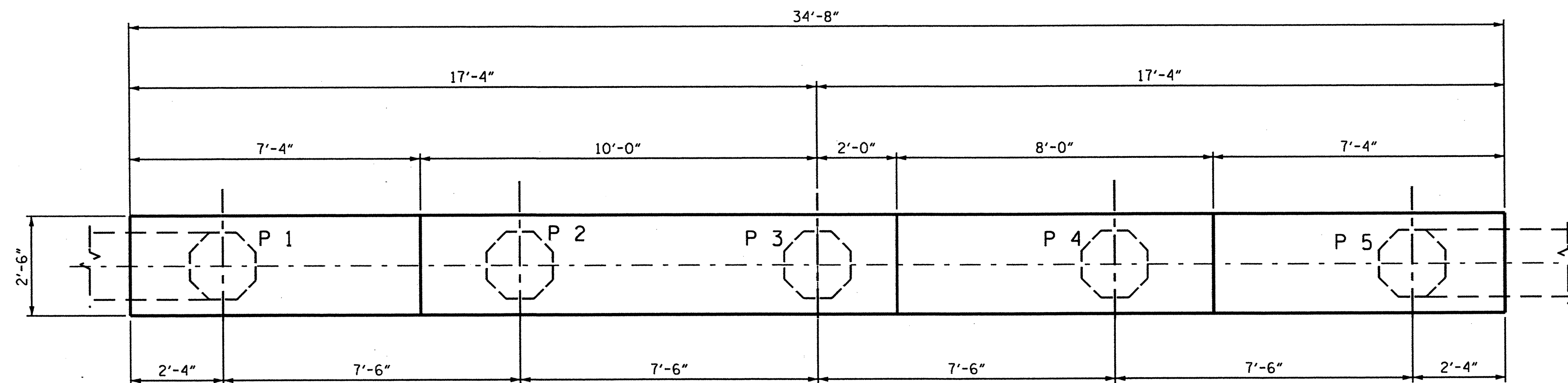

PLAN OF BENT No. 1
(BENT No. 2 SIMILAR)

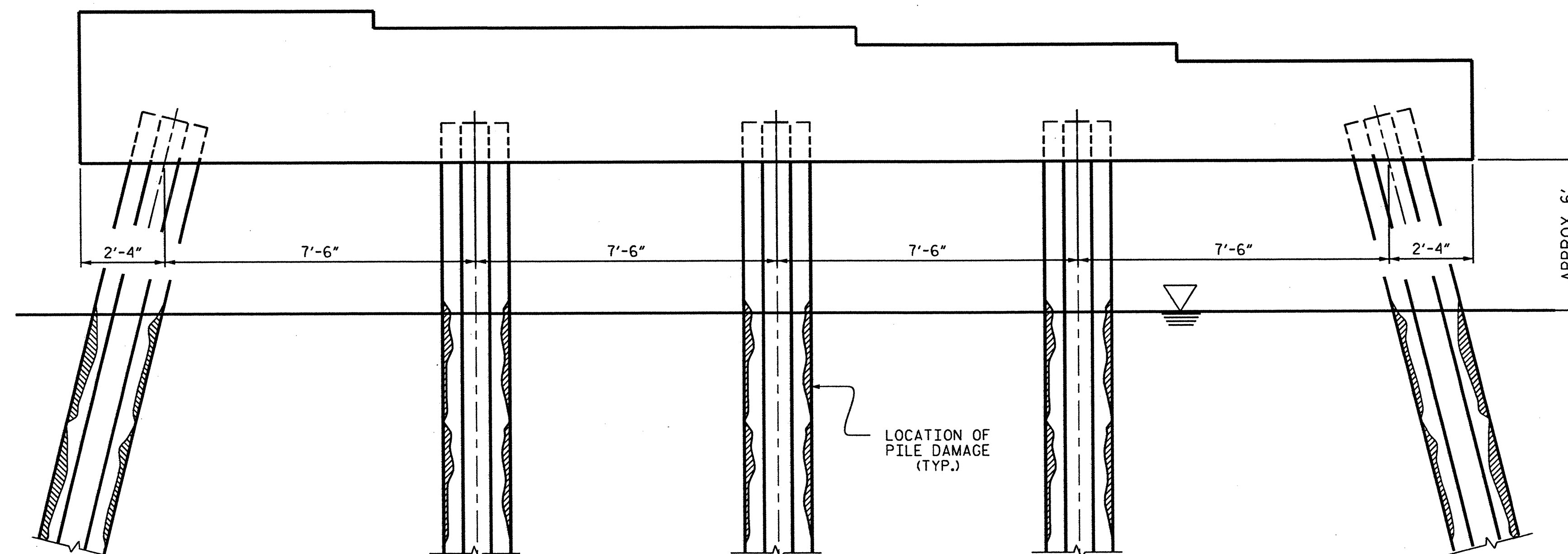

ELEVATION VIEW BENT No. 1
(BENT No. 2 SIMILAR)

PROJECT NO. 17BP.1.P.3
 COUNTY: MARTIN
 DECK REPAIR BRIDGE NO. 42
 SHEET 5 OF 7

STATE OF NORTH CAROLINA
 DEPARTMENT OF TRANSPORTATION
 RALEIGH

PILE REPAIRS

BENTS #1, #2 AND #3

REVISIONS						SHEET NO. S-48
NO.	BY:	DATE:	NO.	BY:	DATE:	
1			3			TOTAL SHEETS 50
2			4			

DRAWN BY : K.H. COMPTON DATE : 10/11
 CHECKED BY : D. SNOKE DATE : 10/11

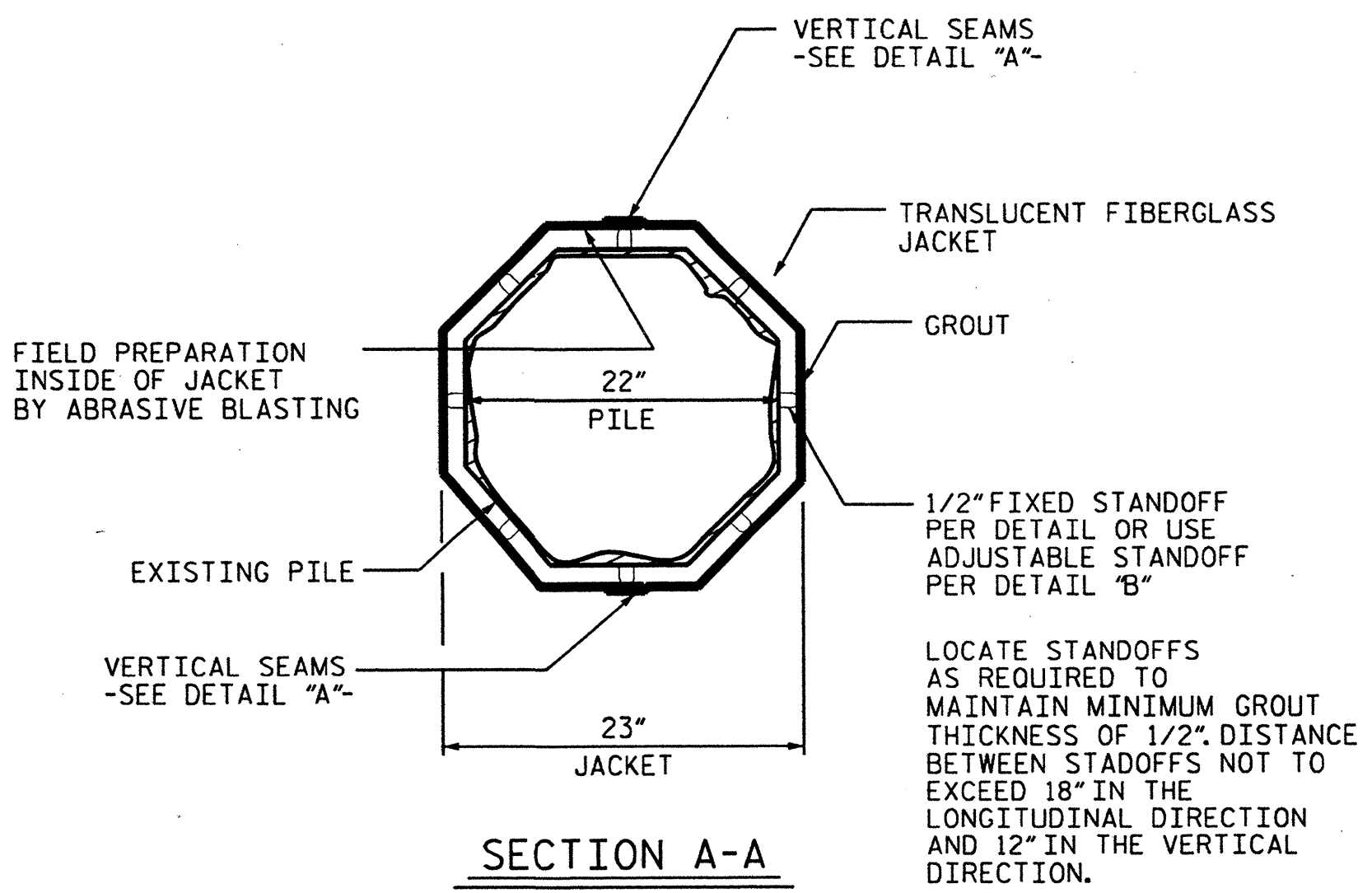
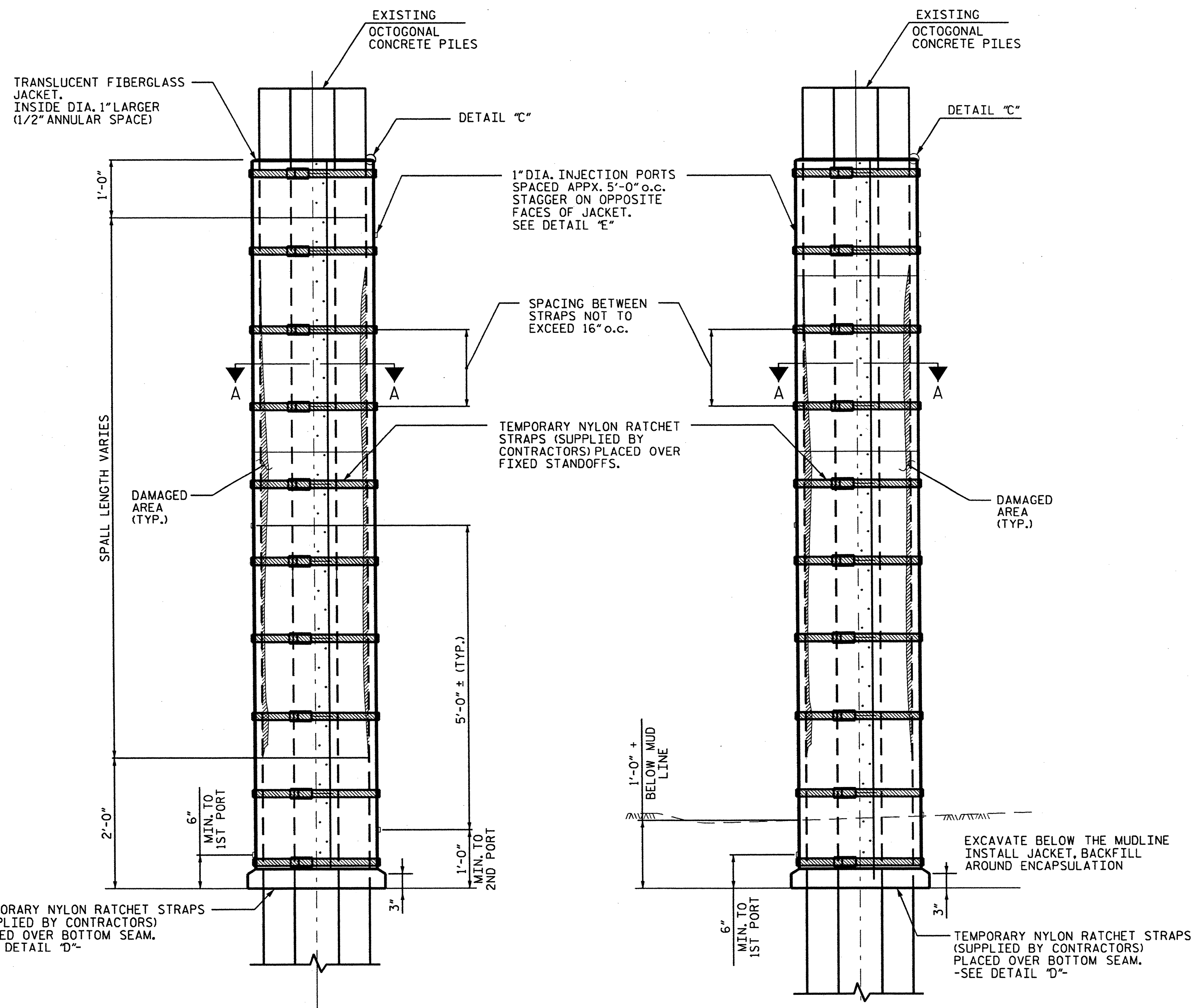

REPAIR SEQUENCES

1. AFTER SURFACE PREPARATION, PLACE JACKET IN PROPER LOCATION AROUND PILE AND SEAL LONGITUDINAL SEAMS (SEE DETAIL "A"). INSTALL TEMPORARY BRACING.
2. CONFIRM SPACING BETWEEN JACKET AND PILE. INSTALL BOTTOM SEAL (SEE DETAIL "D"). ALLOW BOTTOM SEAL TO CURE APPX. 4 HOURS.
3. ATTACH GROUT HOSE TO LOWERMOST INJECTION PORT AND PUMP EPOXY GROUT FOR 30-sec. CHECK FOR LEAKS ALONG SEAMS AND BOTTOM SEAL. (OPTIONALLY ALLOW THIS GROUT TO CURE AND PROCEED WITH GROUT INJECTION FROM 2ND PORT.)
4. PLUG UPPER INJECTION PORTS AND PUMP GROUT INTO LOWER PORT UNTIL GROUT REACHES TOP OF JACKET. ONLY USE UPPER PORTS IF INJECTION BECOMES DIFFICULT.

PROJECT NO. 17BP.1.P.3
 COUNTY: MARTIN
 DECK REPAIR BRIDGE NO. 42
 SHEET 6 OF 7

STATE OF NORTH CAROLINA DEPARTMENT OF TRANSPORTATION RALEIGH					
OCTOGONAL PILE ENCAPSULATION					
REVISIONS					SHEET NO.
NO.	BY:	DATE:	NO.	BY:	DATE:
1			3		
2			4		
TOTAL SHEETS					50

DRAWN BY : K.H. COMPTON DATE : 10/11
 CHECKED BY : D. SNOKE DATE : 10/11

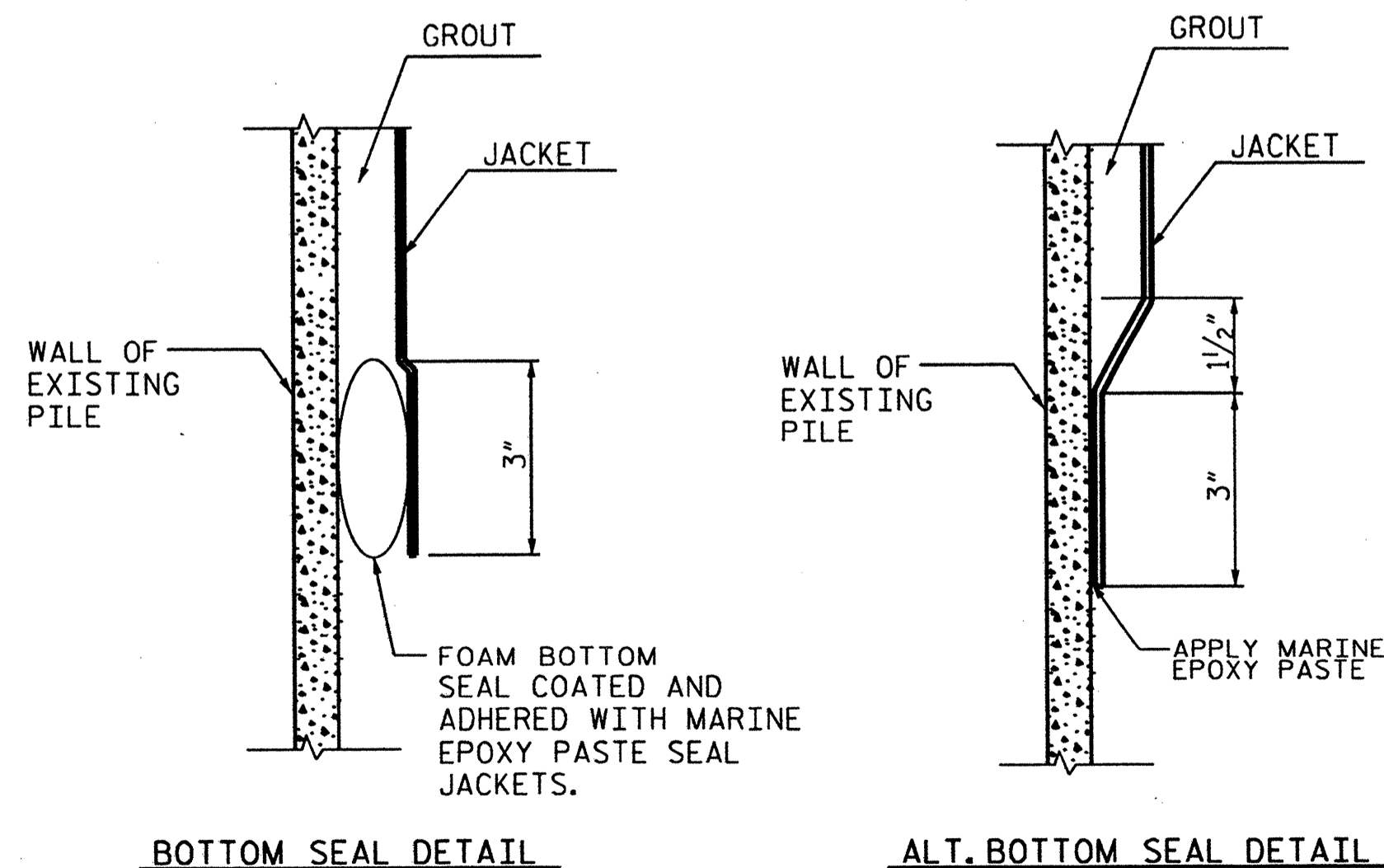
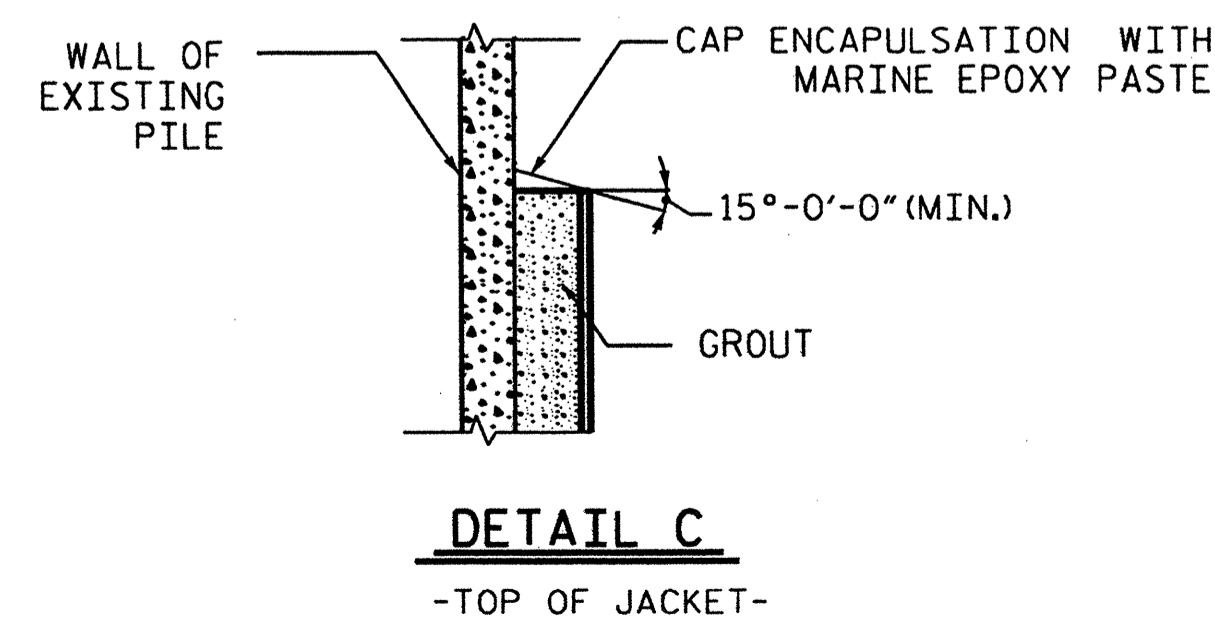
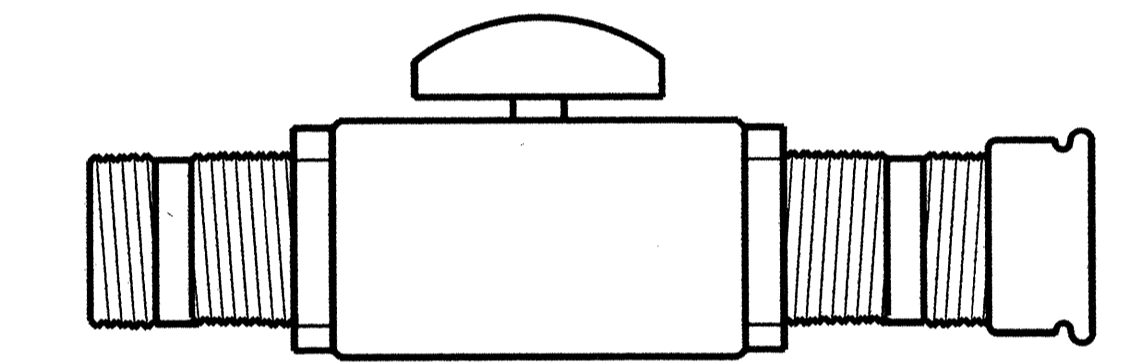
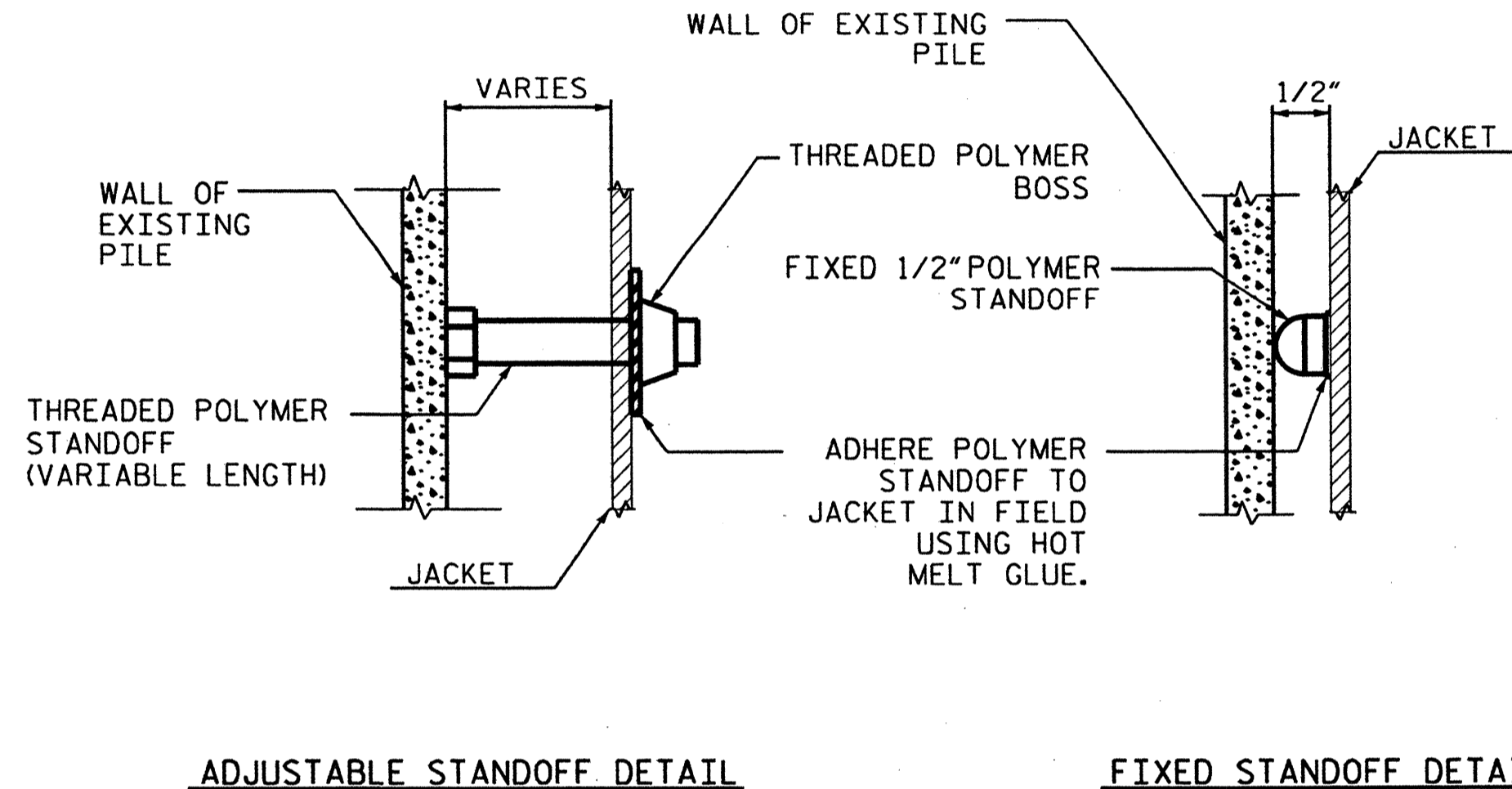
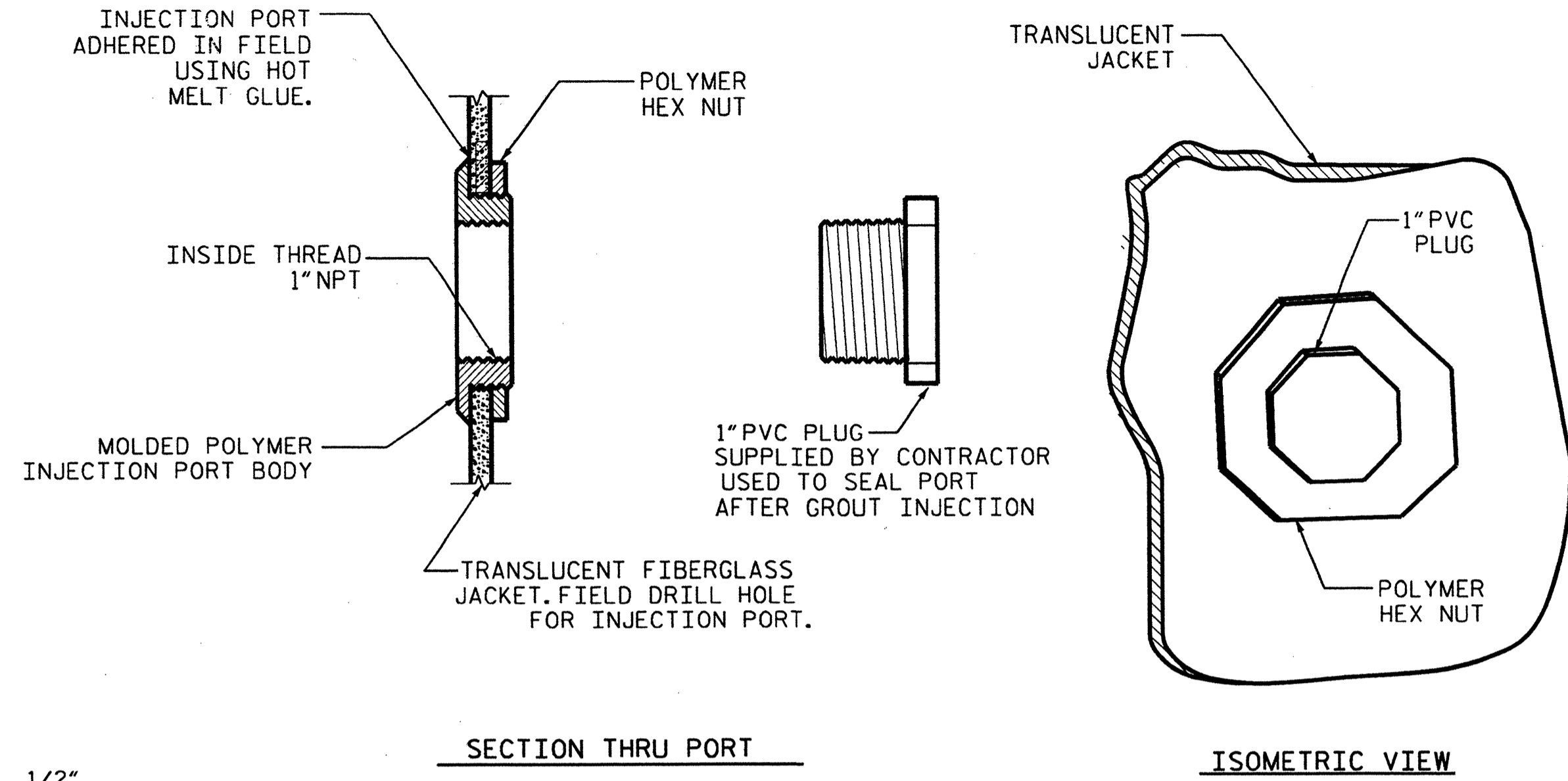
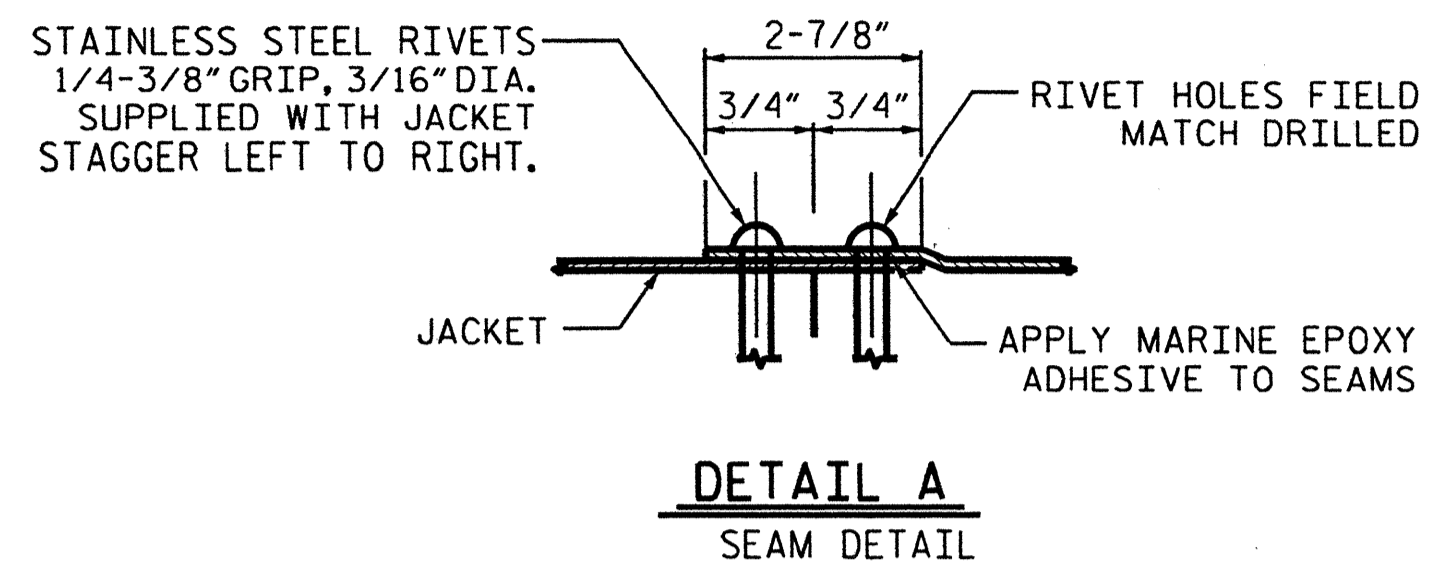
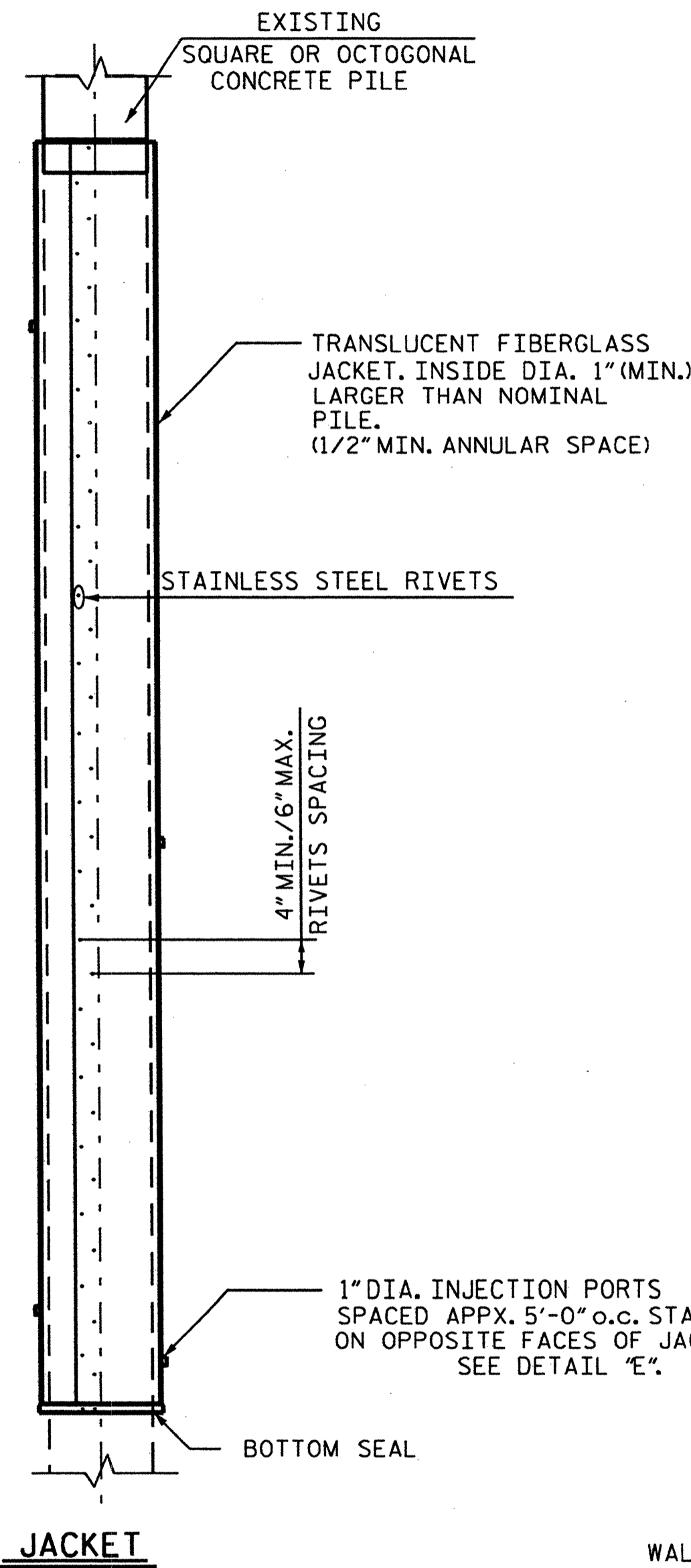

PROJECT NO. 17BP.1.P.3
 COUNTY: MARTIN
 DECK REPAIR BRIDGE NO. 42
 SHEET 7 OF 7

STATE OF NORTH CAROLINA DEPARTMENT OF TRANSPORTATION RALEIGH						SHEET NO. S-50
PILE ENCAPSULATION DETAILS						TOTAL SHEETS 50
REVISIONS						
NO.	BY:	DATE:	NO.	BY:	DATE:	
1			3			
2			4			

DRAWN BY: K.H. COMPTON DATE: 10/11
 CHECKED BY: D. SNOKE DATE: 10/11

STATE OF NORTH CAROLINA
DIVISION OF HIGHWAYS

TRANSPORTATION MANAGEMENT PLAN

BERTIE AND MARTIN COUNTIES

DIVISION 1

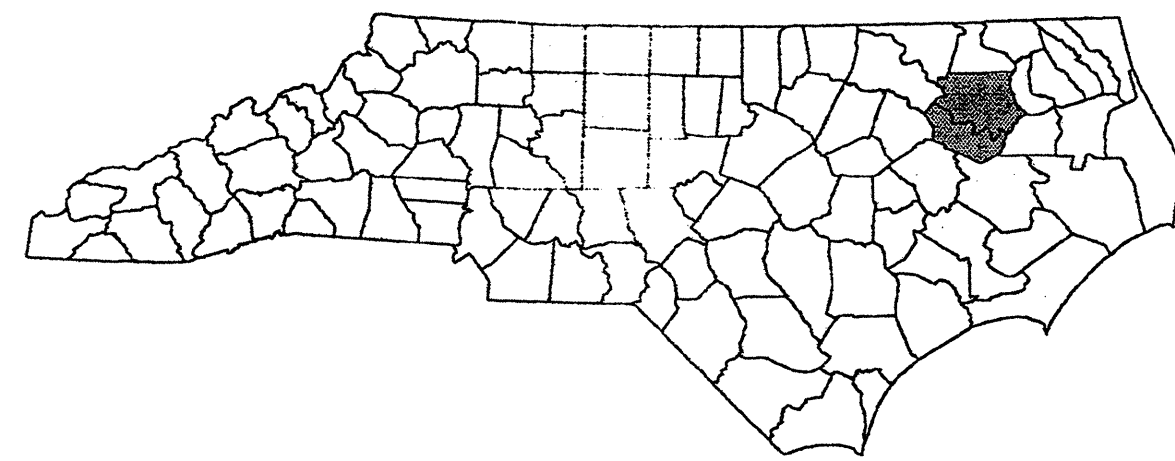

BRIDGE DECK PRESERVATION

- BERTIE BRIDGE #12 – US 13 NORTH OVER ROANOKE RIVER**
- BERTIE BRIDGE #25 – US 13 NORTH OVER ROANOKE RIVER**
- BERTIE BRIDGE #35 – US 13 NORTH OVER CONNIE CREEK**
- BERTIE BRIDGE #47 – US 13 NORTH OVER ROANOKE RIVER**
- BERTIE BRIDGE #49 – US 13 NORTH OVER ROQUIST CREEK**
- BERTIE BRIDGE #50 – US 13 SOUTH OVER ROQUIST CREEK**
- MARTIN BRIDGE #7 – US 64 EAST OVER SWEETWATER CREEK**
- MARTIN BRIDGE #12 – NC 125 OVER CONOHO CREEK**
- MARTIN BRIDGE #14 – NC 11 OVER CONOHO CREEK**
- MARTIN BRIDGE #28 – NC 125 OVER CONOHO CREEK**
- MARTIN BRIDGE #42 – SR 1528 OVER HARDISON MILL CREEK**

I:\28\2011\TrafficControl\BL-17BP.I.P.3 Bertie Martin\TCP\Plan Sheets\BL-17BP.I.P.3.TC.TMP-01.TITLE.dgn

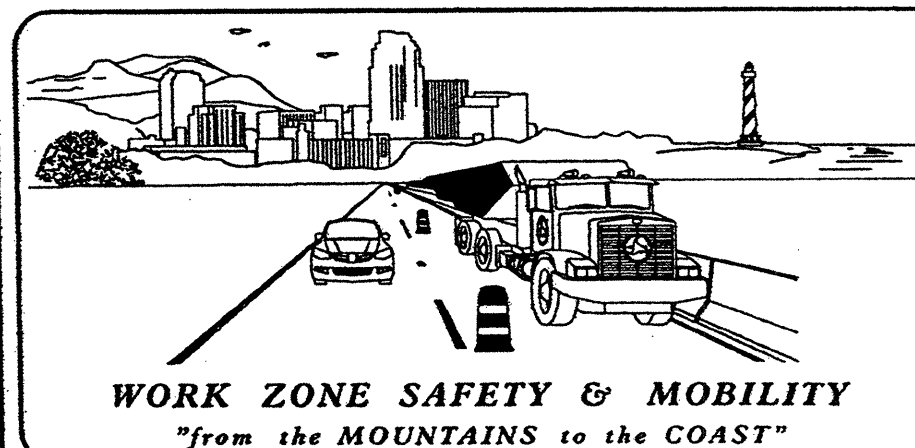

PLAN PREPARED FOR NCDOT BRIDGE MANAGEMENT UNIT
RALEIGH, NC

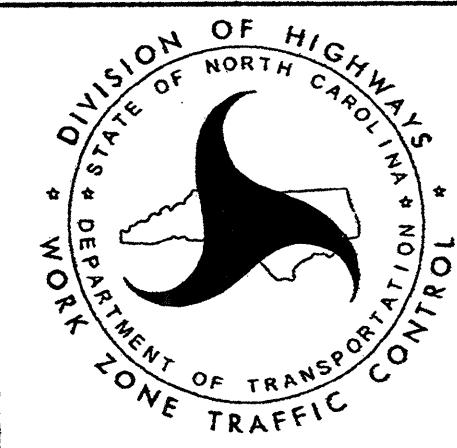

INDEX OF SHEETS

SHEET NO.	TITLE
TMP-1	TITLE SHEET & INDEX OF SHEETS
TMP-1A	LIST OF ROADWAY STANDARD DRAWINGS & LEGEND
TMP-2	GENERAL NOTES
TMP-3	TRAFFIC CONTROL PHASING
TMP-4	BERTIE CO. BRIDGE SECTIONS
TMP-4A	SINGLE LANE CLOSURES USING PORTABLE CONCRETE BARRIER
TMP-5	MARTIN CO. BRIDGE #7 US 64 EASTBOUND CLOSURE OF LEFT LANE
TMP-6	MARTIN CO. BRIDGE #7 US 64 EASTBOUND CLOSURE OF RIGHT LANE

TRAFFIC MANAGEMENT STRATEGY

BERTIE BRIDGES #25, #35, #47: WORK PERFORMED USING LANE CLOSURES AND PORTABLE CONCRETE BARRIER.

BERTIE BRIDGES #12, #49: WORK PERFORMED USING LANE CLOSURES.

BERTIE BRIDGE #50: WORK PERFORMED USING TIME RESTRICTED LANE CLOSURES.

MARTIN BRIDGE #7: WORK PERFORMED USING LANE CLOSURES.

MARTIN BRIDGE #12, #14, #28: WORK PERFORMED USING FLAGGER OPERATION LANE CLOSURES.

MARTIN BRIDGE #42: WORK PERFORMED USING ROAD CLOSURE WITHOUT A SIGNED DETOUR ROUTE.



PLAN PREPARED BY:
Stantec Consulting Services Inc.
801 Jones Franklin Road-Suite 300
Raleigh, NC 27606
Tel. 919.851.6866
Fax. 919.851.7024
www.stantec.com

BETSY L. WATSON, P.E. TRAFFIC ENGINEER
GEORGE KARAGEORGE SR. TRANSPORTATION DESIGNER

APPROVED: *Betsy L. Watson*
DATE: 11/28/11

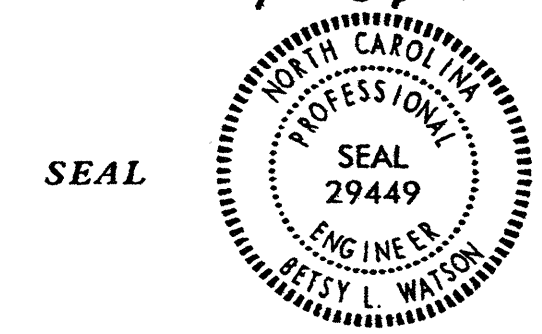



WBS 17BP.I.P.3







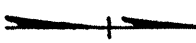



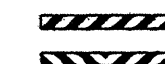

SHEET NO.
TMP-1

LEGEND

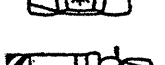
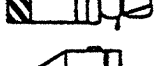

GENERAL

-  DIRECTION OF TRAFFIC FLOW
-  WORK AREA
-  NORTH ARROW

TRAFFIC CONTROL DEVICES

-  BARRICADE (TYPE III)
-  CONE
-  DRUM  SKINNY DRUM  TUBULAR MARKER
-  TEMPORARY CRASH CUSHION
-  FLASHING ARROW BOARD (TYPE C)
-  FLAGGER
-  AUTOMATED FLAGGER ASSISTANCE DEVICE (AFAD)
-  LAW ENFORCEMENT
-  TRUCK MOUNTED ATTENUATOR (TMA)
-  PORTABLE CHANGEABLE MESSAGE SIGN (CMS)
-  PORTABLE CONCRETE BARRIER (PCB)





TEMPORARY SIGNING

-  PORTABLE SIGN
-  STATIONARY SIGN
-  STATIONARY OR PORTABLE SIGN

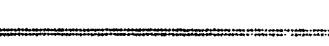

SIGNALS

-  EXISTING
-  PROPOSED
-  TEMPORARY



PAVEMENT MARKINGS

-  EXISTING PAVEMENT MARKING (GRAY)
-  SKIP LINES
-  MINI-SKIP LINES
-  SOLID LINES

PAVEMENT MARKING SYMBOLS

-  PAVEMENT MARKING SYMBOLS
-  EXISTING PAVEMENT MARKING SYMBOLS (HOLLOW)
-  ONLY PAVEMENT MARKING ALPHANUMERIC CHARACTERS

PAVEMENT MARKERS

-  CRYSTAL/CRYSTAL
-  CRYSTAL/RED
-  YELLOW/YELLOW

ROADWAY STANDARD DRAWINGS

THE FOLLOWING ROADWAY STANDARDS AS APPEAR IN "ROADWAY STANDARD DRAWINGS" - PROJECT SERVICES UNIT - N.C. DEPARTMENT OF TRANSPORTATION - RALEIGH, N.C., DATED JANUARY 2012 ARE APPLICABLE TO THIS PROJECT AND BY REFERENCE HEREBY ARE CONSIDERED A PART OF THESE PLANS:

STD. NO.	TITLE
1101.01	WORK ZONE ADVANCE WARNING SIGNS
1101.02	TEMPORARY LANE CLOSURES
1101.03	TEMPORARY ROAD CLOSURES
1101.04	TEMPORARY SHOULDER CLOSURES
1101.11	TRAFFIC CONTROL DESIGN TABLES
1110.01	STATIONARY WORK ZONE SIGNS
1110.02	PORTABLE WORK ZONE SIGNS
1115.01	FLASHING ARROW BOARDS
1130.01	DRUMS
1135.01	CONES
1145.01	BARRICADES
1150.01	FLAGGING DEVICES
1160.01	TEMPORARY CRASH CUSHION
1165.01	WORK VEHICLE LIGHTING SYSTEMS AND TMA DELINEATION
1170.01	PORTABLE CONCRETE BARRIER
1180.01	SKINNY - DRUM
1205.01	PAVEMENT MARKINGS - LINE TYPES AND OFFSETS
1205.02	PAVEMENT MARKINGS - TWO LANE AND MULTILANE ROADWAYS
1250.01	RAISED PAVEMENT MARKERS - INSTALLATION SPACING
1251.01	RAISED PAVEMENT MARKERS - (PERMANENT)
1261.01	GUARDRAIL AND BARRIER DELINEATORS - INSTALLATION SPACING
1261.02	GUARDRAIL AND BARRIER DELINEATORS - TYPES AND MOUNTING

I:\28\2011\TrafficControl\BL-17BP.IP.3.Berrie.Martin\TCP\Plan Sheets\BL-17BP.IP.3.TC.TMP.OIA.RDWYSTDLEGEND.dgn
 gkrcgbrg

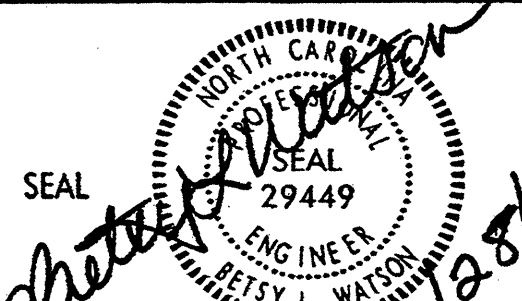
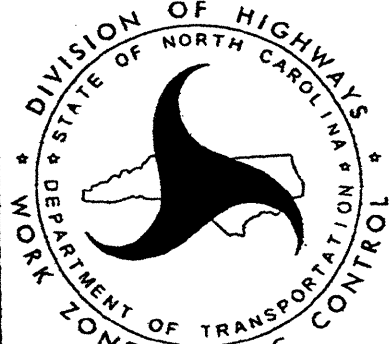
 Stantec	Stantec Consulting Services Inc. 801 Jones Franklin Road Suite 300 Raleigh, NC 27606 Tel. (919) 851-6866 Fax. (919) 851-7024 www.stantec.com License No. F-0572	APPROVED: _____ DATE: _____  SEAL R. L. WATSON ENGINEER 29449 11/28/11	 DIVISION OF HIGHWAYS DEPARTMENT OF TRANSPORTATION WORK ZONE TRAFFIC CONTROL	ROADWAY STANDARD DRAWINGS & LEGEND
---	--	---	--	---

GENERAL NOTES

PROJ. REFERENCE NO.	SHEET NO.
17BP.1.P.3	TMP-2

THE FOLLOWING GENERAL NOTES APPLY AT ALL TIMES FOR THE DURATION OF THE PROJECT EXCEPT WHEN OTHERWISE NOTED IN THE PLAN OR DIRECTED BY THE ENGINEER.

CHANGES MAY BE REQUIRED WHEN PHYSICAL DIMENSIONS IN THE DETAIL DRAWINGS, STANDARD DETAILS, AND ROADWAY DETAILS ARE NOT ATTAINABLE TO MEET FIELD CONDITIONS OR RESULT IN DUPLICATE OR UNDESIRABLE OVERLAPPING OF DEVICES. MODIFICATION MAY INCLUDE: MOVING, SUPPLEMENTING, COVERING, OR REMOVAL OF DEVICES AS DIRECTED BY THE ENGINEER.

HOLIDAY & HOLIDAY WEEKEND LANE CLOSURE TIME RESTRICTIONS

A) DO NOT CLOSE OR NARROW TRAVEL LANES DURING HOLIDAYS AND HOLIDAY WEEKENDS AS FOLLOWS:

ROAD NAME
US 13 & US 64

- 1) FOR ANY UNEXPECTED OCCURRENCE THAT CREATES UNUSUALLY HIGH TRAFFIC VOLUMES, AS DIRECTED BY THE ENGINEER.
- 2) FOR NEW YEAR'S, BETWEEN THE HOURS OF 6:00 A.M. DECEMBER 31st TO 7:00 P.M. JANUARY 2nd. IF NEW YEAR'S DAY IS ON A FRIDAY, SATURDAY, SUNDAY, OR MONDAY THEN UNTIL 7:00 P.M. THE FOLLOWING TUESDAY.
- 3) FOR EASTER, BETWEEN THE HOURS OF 6:00 A.M. THURSDAY AND 7:00 P.M. MONDAY.
- 4) FOR MEMORIAL DAY, BETWEEN THE HOURS OF 6:00 A.M. FRIDAY TO 7:00 P.M. TUESDAY.
- 5) FOR INDEPENDENCE DAY, BETWEEN THE HOURS OF 6:00 A.M. THE DAY BEFORE INDEPENDENCE DAY AND 7:00 P.M. THE DAY AFTER INDEPENDENCE DAY. IF INDEPENDENCE DAY IS ON A FRIDAY, SATURDAY, SUNDAY OR MONDAY; THEN BETWEEN THE HOURS OF 6:00 A.M. THE THURSDAY BEFORE INDEPENDENCE DAY AND 7:00 P.M. THE TUESDAY AFTER INDEPENDENCE DAY.
- 6) FOR LABOR DAY, BETWEEN THE HOURS OF 6:00 A.M. FRIDAY AND 7:00 P.M. TUESDAY.
- 7) FOR THANKSGIVING DAY, BETWEEN THE HOURS OF 6:00 A.M. TUESDAY TO 7:00 P.M. MONDAY.
- 8) FOR CHRISTMAS, BETWEEN THE HOURS OF 6:00 A.M. THE FRIDAY BEFORE THE WEEK OF CHRISTMAS DAY AND 7:00 P.M. THE FOLLOWING TUESDAY AFTER THE WEEK OF CHRISTMAS.

LANE AND SHOULDER CLOSURE REQUIREMENTS

- B) LANE CLOSURES ARE REQUIRED WHEN PERSONNEL AND/OR EQUIPMENT ARE WORKING WITHIN ANY PORTION OF A TRAVEL LANE. CONDUCT THE WORK SO THAT ALL PERSONNEL AND/OR EQUIPMENT REMAIN WITHIN THE CLOSED TRAVEL LANE.
- C) INSTALL ALL LANE CLOSURES ACCORDING TO THE PLANS, ROADWAY STANDARD DRAWINGS (1101.02), OR AS DIRECTED BY THE ENGINEER.
- D) WHEN PERSONNEL AND/OR EQUIPMENT ARE WORKING WITHIN 15 FT OF AN OPEN TRAVEL LANE, CLOSE THE NEAREST OPEN SHOULDER USING ROADWAY STANDARD DRAWING NO. 1101.04 UNLESS THE WORK AREA IS PROTECTED BY BARRIER OR GUARDRAIL OR A LANE CLOSURE IS INSTALLED.
- E) WHEN PERSONNEL AND/OR EQUIPMENT ARE WORKING ON THE SHOULDER ADJACENT TO AN UNDIVIDED FACILITY AND WITHIN 5 FT OF AN OPEN TRAVEL LANE, CLOSE THE NEAREST OPEN TRAVEL LANE UNLESS THE WORK AREA IS PROTECTED BY BARRIER OR GUARDRAIL.
- F) WHEN PERSONNEL AND/OR EQUIPMENT ARE WORKING ON THE SHOULDER ADJACENT TO A DIVIDED FACILITY AND WITHIN 10 FT OF AN OPEN TRAVEL LANE, CLOSE THE NEAREST OPEN TRAVEL LANE UNLESS THE WORK AREA IS PROTECTED BY BARRIER OR GUARDRAIL.

ROAD CLOSURES

- G) NOTIFY THE ENGINEER TWENTY ONE (21) CALENDAR DAYS PRIOR TO ANY TRAFFIC PATTERN ALTERATION.
- H) PROVIDE SIGNING AND DEVICES FOR ROAD CLOSURES ACCORDING TO THE TRAFFIC MANAGEMENT PLAN. COVER OR REMOVE ALL SIGNS AND DEVICES FOR ROAD CLOSURES WHEN NOT IN EFFECT.

PAVEMENT MARKINGS AND MARKERS

- I) RECORD ALL LOCATIONS AND TYPES OF EXISTING PAVEMENT MARKINGS AS THEY WILL BE REPLACED IN THE SAME LOCATION ON THE NEW SURFACE.
- J) UPON COMPLETION OF ALL OTHER CONSTRUCTION OPERATIONS INSTALL PAVEMENT MARKINGS AND PAVEMENT MARKERS ON THE FINAL SURFACE AS FOLLOWS:

<u>ROAD NAME</u>	<u>MARKING</u>	<u>PAVEMENT MARKER</u>
ALL BRIDGE LOCATIONS	POLYUREA	PERMANENT RAISED

TEMPORARY TRAFFIC BARRIER

- K) INSTALL TEMPORARY BARRIER ACCORDING TO THE PLANS A MAXIMUM OF ONE (1) WEEK PRIOR TO BEGINNING WORK IN ANY LOCATION. ONCE TEMPORARY BARRIER IS INSTALLED, PROCEED IN A CONTINUOUS MANNER TO COMPLETE THE PROPOSED WORK IN THAT LOCATION, UNLESS OTHERWISE STATED IN THE PLANS OR DIRECTED BY THE ENGINEER.
- L) DO NOT PLACE BARRIER DIRECTLY ON ANY SURFACE OTHER THAN ASPHALT OR CONCRETE.
- M) INSTALL TEMPORARY BARRIER WITH THE TRAFFIC FLOW, BEGINNING WITH THE UPSTREAM SIDE OF TRAFFIC. REMOVE TEMPORARY BARRIER AGAINST THE TRAFFIC FLOW, BEGINNING WITH THE DOWNSTREAM SIDE OF TRAFFIC.
- N) INSTALL AND SPACE DRUMS NO GREATER THAN TWICE THE POSTED SPEED LIMIT (MPH) TO CLOSE OR KEEP THE SECTION OF THE ROADWAY CLOSED UNTIL THE TEMPORARY BARRIER CAN BE PLACED OR AFTER THE TEMPORARY BARRIER IS REMOVED.
- O) PROTECT THE APPROACH END OF PORTABLE CONCRETE BARRIER AT ALL TIMES DURING THE INSTALLATION AND REMOVAL OF THE BARRIER BY EITHER A TRUCK MOUNTED ATTENUATOR (MAXIMUM 72 HOURS) OR A TEMPORARY CRASH CUSHION.

MISCELLANEOUS

- P) ALL DIMENSIONS AND STATIONS IN THE TRAFFIC MANAGEMENT PLAN AND PHASING ARE APPROXIMATE (+/-); FIELD ADJUST AS NECESSARY OR AS DIRECTED BY THE ENGINEER.
- Q) ENSURE THE OVERSIZE/OVERWEIGHT PERMIT UNIT (919) 733-4740 HAS BEEN ADVISED OF THE ONGOING TRAFFIC OPERATIONS THROUGH THE DIVISION OFFICE.

I:\31\2012\UN\TrafficControl\17BP.1.P.3 Bertie Martin\TCPlan Sheets\17BP.1.P.3.TC.TMP.02.GENERALNOTES.dgn
okoragor

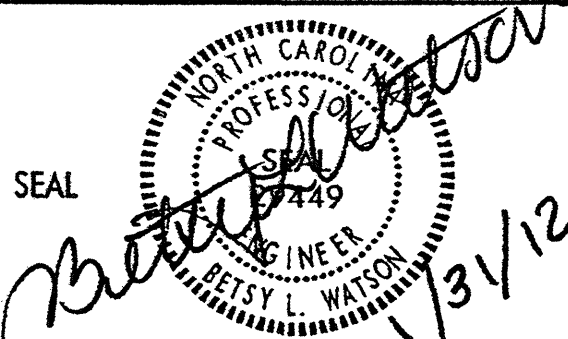
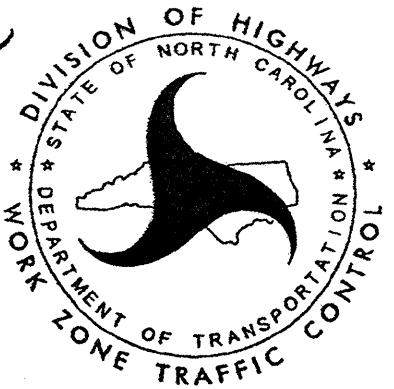
 Stantec Consulting Services Inc. 801 Jones Franklin Road Suite 300 Raleigh, NC 27606 Tel. (919) 851-8896 Fax. (919) 851-7024 www.stantec.com License No. F-0672	APPROVED: _____ DATE: _____ 		GENERAL NOTES
---	--	---	---------------

TTC PHASING

DO NOT WORK ON BRIDGES SIMULTANEOUSLY IN THE SAME DIRECTION OF TRAVEL

BERTIE CO. BRIDGES #25, #35, #47

PERFORM THE BRIDGE WORK USING RIGHT AND LEFT LANE CLOSURES WITH PORTABLE CONCRETE BARRIER AS SHOWN ON SHEET TMP-4A.

REFER TO BRIDGE TYPICAL SECTIONS ON SHEET TMP-4.

BERTIE CO. BRIDGES #12, #49, #50

PERFORM THE BRIDGE WORK USING RIGHT AND LEFT LANE CLOSURES PER ROADWAY STANDARD DRAWING 1101.02, SHEET 3.

REFER TO BRIDGE TYPICAL SECTIONS ON SHEET TMP-4.

MARTIN CO. BRIDGE #7 - US 64 EASTBOUND OVER SWEETWATER CREEK

PERFORM THE BRIDGE WORK USING RIGHT AND LEFT LANE CLOSURES AS SHOWN ON SHEET TMP-5 AND TMP-6.

MARTIN CO. BRIDGE #12, #14, #28

PERFORM THE WORK USING AUTOMATED FLAGGING ASSISTANCE DEVICES PER ROADWAY STANDARD DRAWING 1101.02, SHEET 14. FLAGGER CONTROLLED LANE CLOSURES MAY ALSO BE USED WHEN ALLOWED BY THE ENGINEER PER ROADWAY STANDARD DRAWING 1101.02, SHEET 1.

MARTIN CO. BRIDGE #42-SR 1528(YARRELL CREEK RD) OVER HARDISON MILL CREEK

PERFORM THE WORK USING A ROAD CLOSURE. CLOSE SR 1528 (YARRELL CREEK RD) PER ROADWAY STANDARD DRAWING 1101.03, SHEET 1, TEMPORARY ROAD CLOSURE BEYOND A DETOUR POINT.

I:\28\2011\TrafficControl\BL-17BP.I.P.3 Bertie Martin\TC\Plan Sheets\BL-17BP.I.P.3_TC_TMP_03_PHASING.dgn

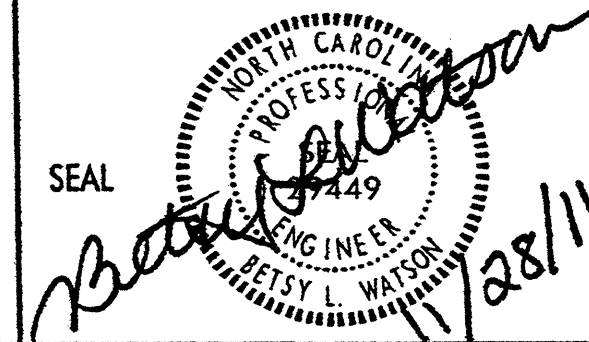
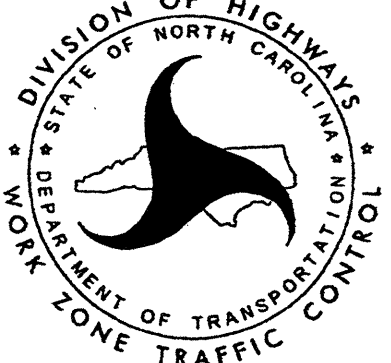
 <p>Stantec Consulting Services Inc. 801 Jones Franklin Road Suite 300 Raleigh, NC 27606 Tel. (919) 851-6366 Fax. (919) 851-7024 www.stantec.com License No. F-0672</p>	<p>APPROVED: _____ DATE: _____</p> <div style="text-align: center;">  <p>SEAL</p> </div>	 <p style="text-align: center;">DIVISION OF HIGHWAYS STATE OF NORTH CAROLINA DEPARTMENT OF TRANSPORTATION LOOK AHEAD TO THE FUTURE</p>	<p>TEMPORARY TRAFFIC CONTROL PHASING</p>
--	---	---	--

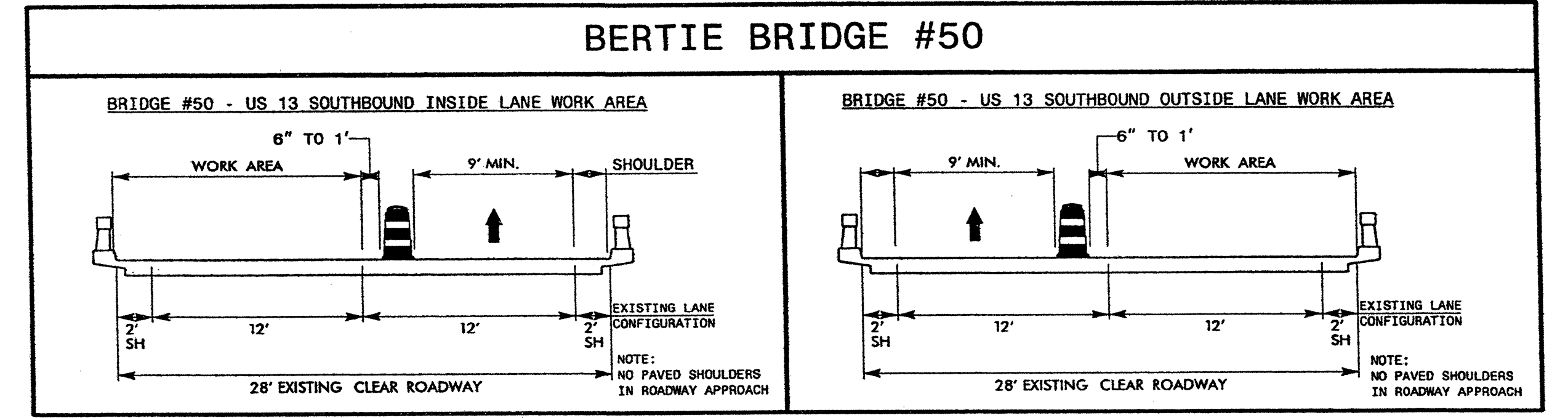
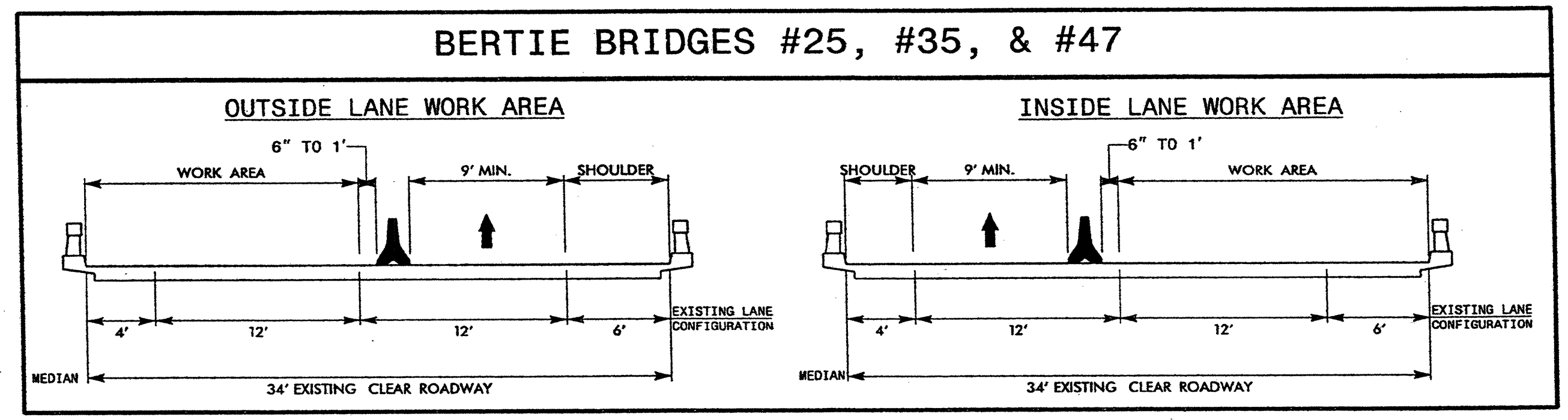
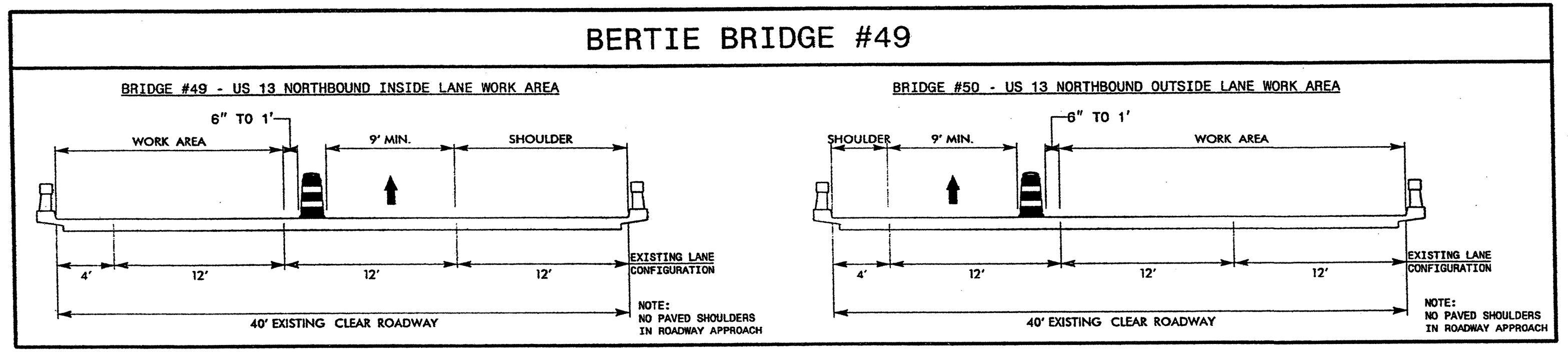
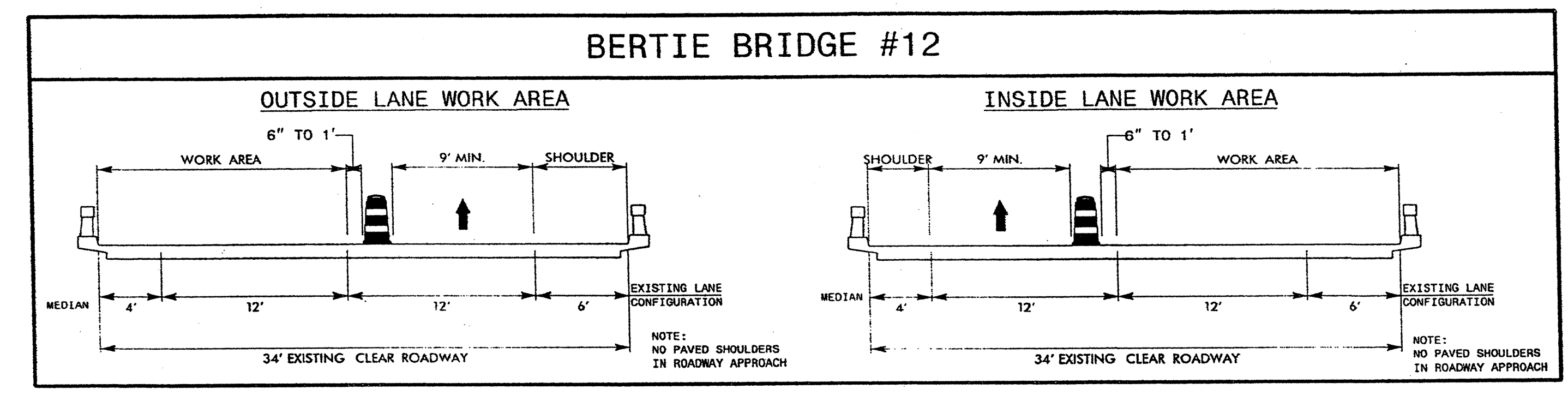

I:\28\2011\TrafficControl\BL-17BP.1.P.3 Bertie Martin\TCP\Plan Sheets\BL-17BP.1.P.3.TC.TMP_04_BERTIE_BRIDGESECTIONS.dgn
 User: gborger

 Stantec Consulting Services Inc. 801 Jones Franklin Road Suite 300 Raleigh, NC 27606 Tel. (919) 851-6886 Fax. (919) 851-7024 www.stantec.com License No. F-0672	APPROVED: _____ DATE: _____ 		<h2 style="margin: 0;">BERTIE BRIDGE TYPICAL SECTIONS</h2>
--	---------------------------------	--	--

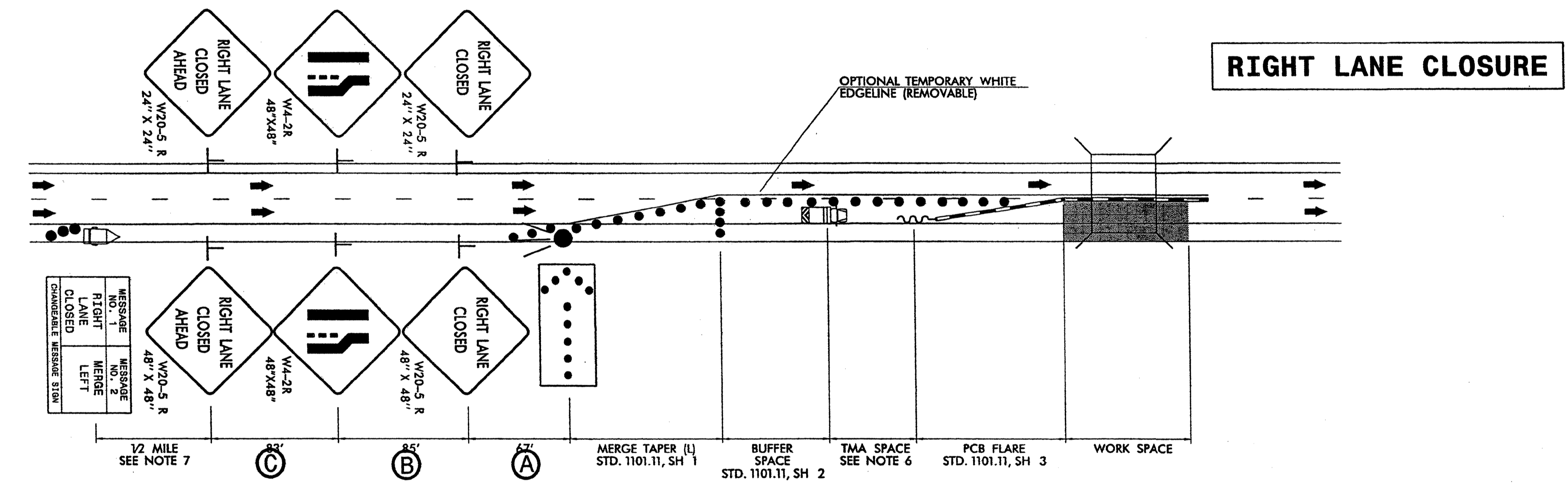
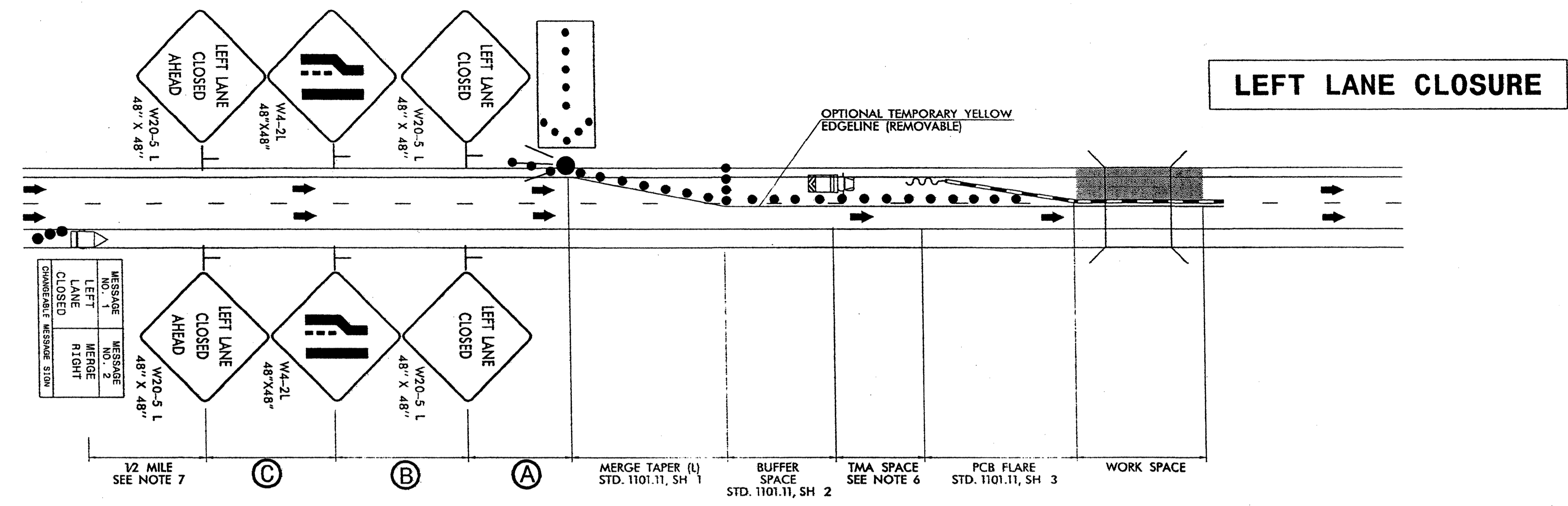

NOTES

- INSTALL LANE CLOSURES WITH THE TRAFFIC FLOW, BEGINNING WITH DEVICES ON THE UPSTREAM SIDE OF TRAFFIC. REMOVE LANE CLOSURES AGAINST THE TRAFFIC FLOW, BEGINNING WITH DEVICES ON THE DOWNSTREAM SIDE OF TRAFFIC.
- STATIONARY SIGNS SHOULD BE USED IF THE LANE CLOSURE WILL BE IN PLACE FOR LONGER THAN 3 CONSECUTIVE DAYS.
- SIGNS ARE NOT REQUIRED ON THE LEFT SIDE OF THE ROADWAY WHEN THERE IS NOT ENOUGH ROOM FOR PLACEMENT. AT CONCRETE BARRIER LOCATIONS CLAMP ATTACHMENTS AND SMALLER SIGNS MAY BE USED.
- PLACE ARROW BOARDS ON THE SHOULDER. IF SHOULDERS DO NOT EXIST, PLACE ARROW BOARDS WITHIN THE MERGE TAPER BEHIND THE CHANNELIZING DEVICES OF THE LANE CLOSURE. IF NEEDED, EXTEND LANE CLOSURES TO PROVIDE STOPPING SIGHT DISTANCE TO THE ARROW BOARD (TABLE 2).
- PLACE LANE CLOSURE DRUMS IN TAPERS AT A MAXIMUM SPACING EQUAL IN FEET TO THE POSTED SPEED LIMIT (MPH). ALONG BUFFER SPACES AND WORK AREAS SPACE DRUMS AT A MAXIMUM SPACING EQUAL IN FEET TO TWICE THE POSTED SPEED LIMIT (MPH). IN ALL CASES, CHANNELIZING DEVICES ARE TO BE SPACED IN SUCH A MANNER AS TO POSITIVELY ACHIEVE THE INTENDED VISUAL CHANNELIZATION. CHANNELIZING DEVICES SHOULD BE LATERALLY OFFSET 3 FT INSIDE THE CLOSED LANE AS ROOM PERMITS.
- POSITION THE TMA TO MAINTAIN A ROLL-AHEAD DISTANCE AS RECOMMENDED BY THE MANUFACTURER.
- IF TRAFFIC BACKS UP TO WHERE THE CMS IS INITIALLY PLACED, RELOCATE CMS 1/2 MILE FROM ANTICIPATED BACKUP. CONTINUE TO MONITOR TRAFFIC AND MOVE CMS APPROXIMATELY 1/2 MILE IN CONJUNCTION WITH ANTICIPATED BACKUP.
- WHEN WORK IS NOT BEING PERFORMED BEHIND THE LANE CLOSURE OR WHEN A LANE CLOSURE IS NO LONGER NEEDED OR AS DIRECTED BY THE ENGINEER, REMOVE LANE CLOSURE DEVICES, COVER OR LAY DOWN SIGNS, AND TURN OFF ARROW BOARD AND MESSAGE BOARDS.

I:\28\2011\TX\TrafficControl\17BP.1.P.3 Bertie Martin\TCP\Plan Sheets\BL-17BP.1.P.3.TC.TMP-04A_SINGLE_LANE_CLOSURES_with_PCB.dgn
 OK or qdeor.08

<p>Stantec Consulting Services Inc. 801 Jones Franklin Road Suite 300 Raleigh, NC 27606 Tel. (919) 851-6866 Fax. (919) 851-7024 www.stantec.com License No. F-0672</p>	APPROVED: _____ DATE: _____ 		<p>SINGLE LANE CLOSURES ON MULTI-LANE ROADWAYS USING PORTABLE CONCRETE BARRIER</p>

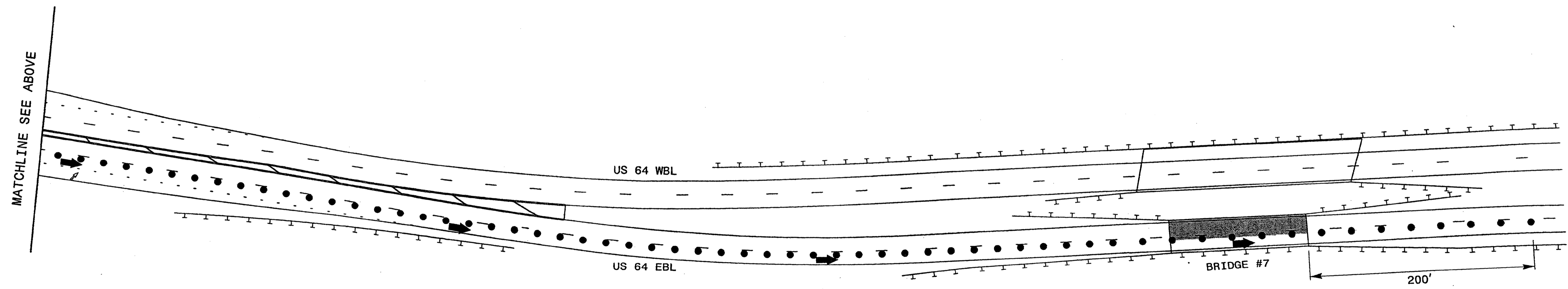
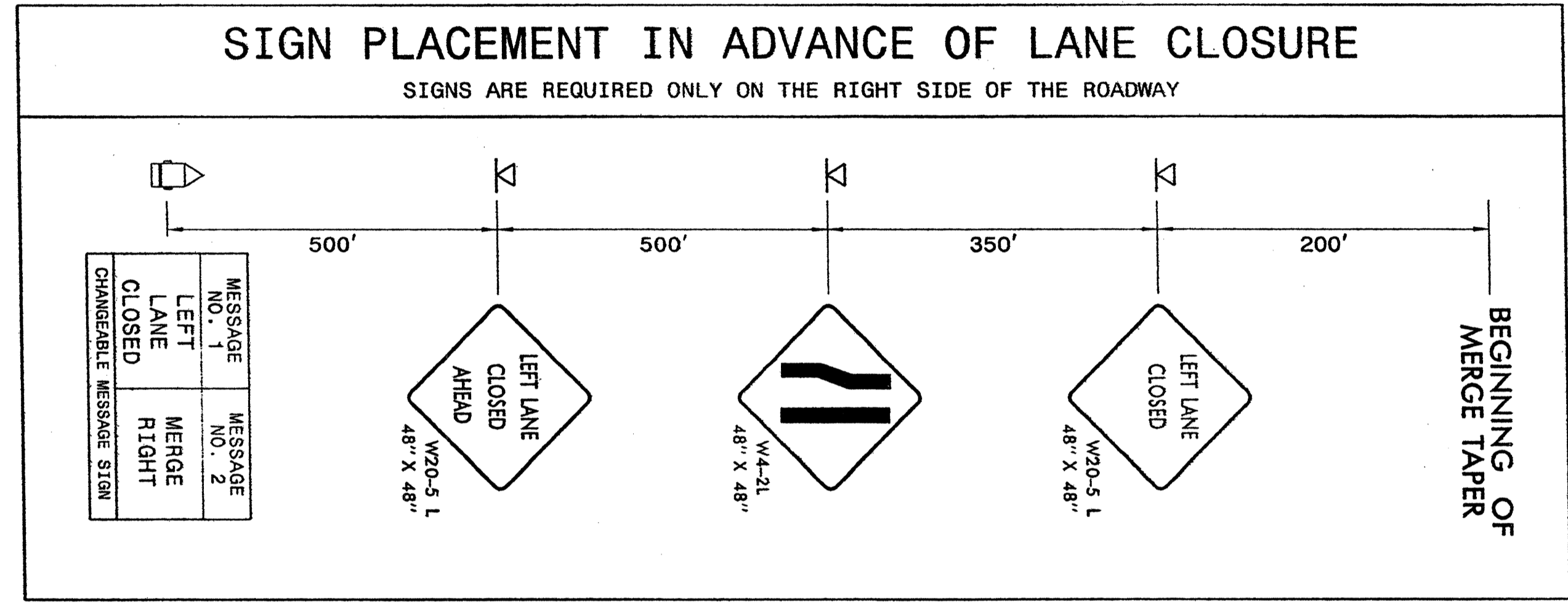
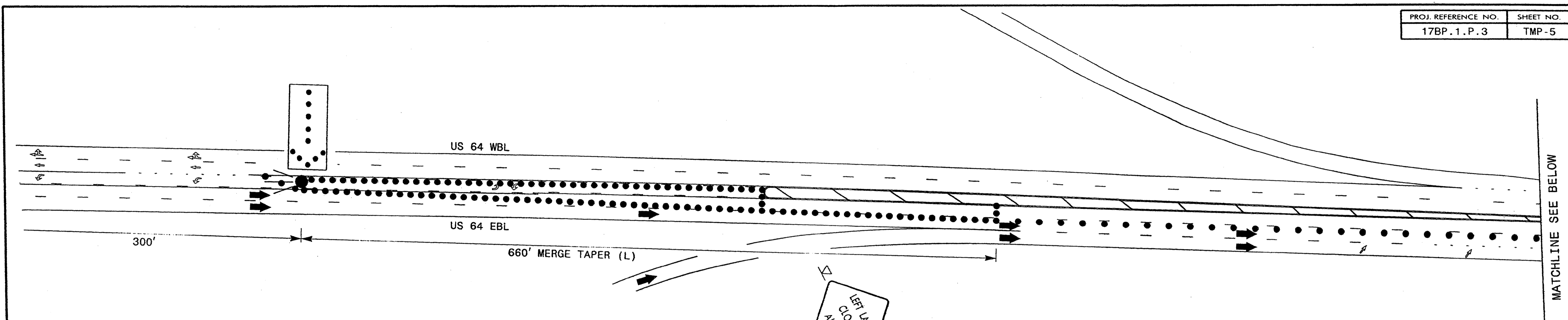

11/28/2011
 U:\Traffic\TrafficControl\17BP.1.P.3 Barrie Martin\TCP\Plan Sheets\BL-17BP.1.P.3.TC.TMP_05.MARTIN.07.LL.dgn
 dkcaro@stantec.com

 Stantec <small>Stantec Consulting Services Inc. 801 Jones Franklin Road Suite 300 Raleigh, NC 27606 Tel. (919) 851-6866 Fax. (919) 851-7024 www.stantec.com License No. F-0672</small>	APPROVED: _____ DATE: _____ 		MARTIN CO. BRIDGE #7 US 64 EASTBOUND LEFT LANE CLOSURE

SIGN PLACEMENT IN ADVANCE OF LANE CLOSURE

SIGNS ARE REQUIRED ONLY ON THE RIGHT SIDE OF THE ROADWAY

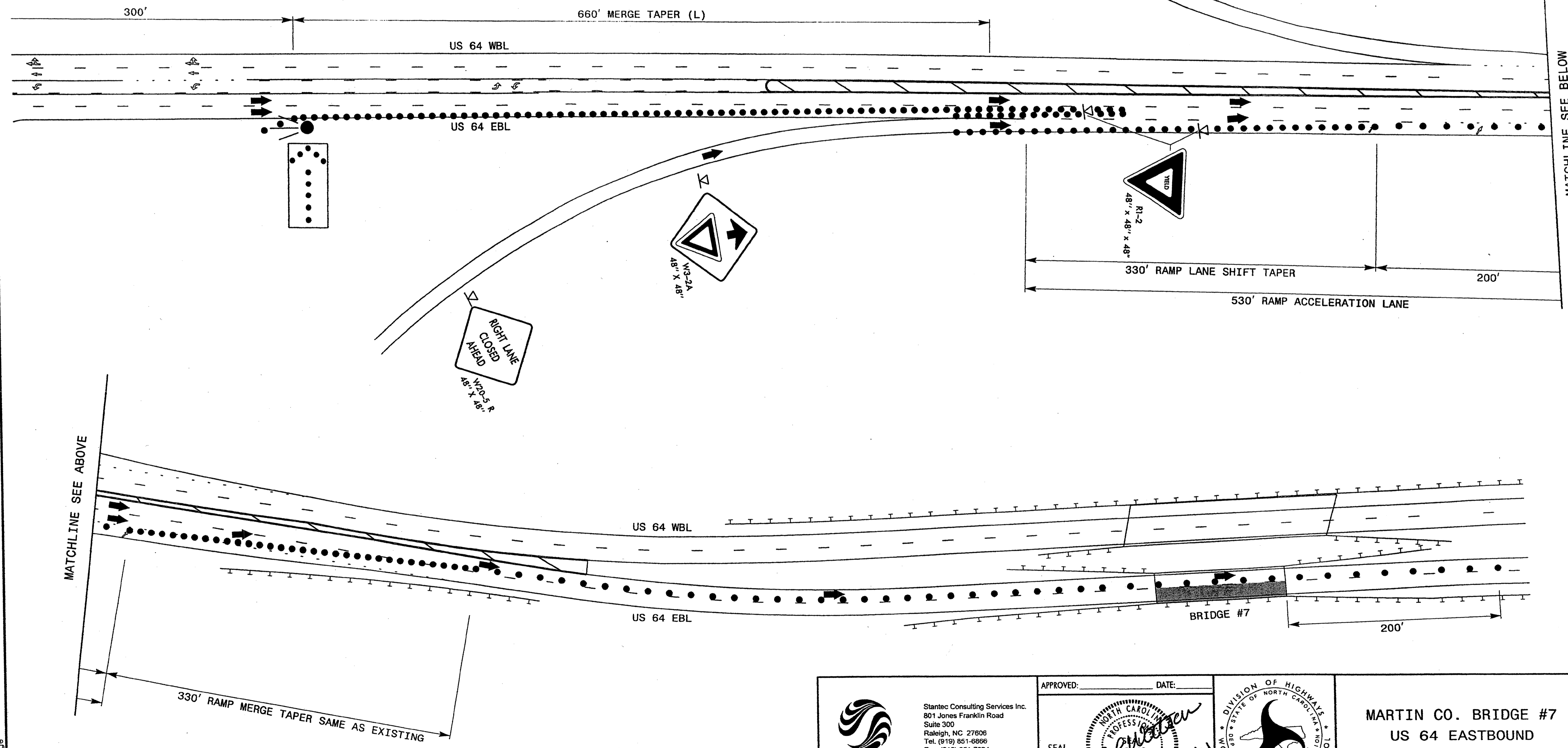
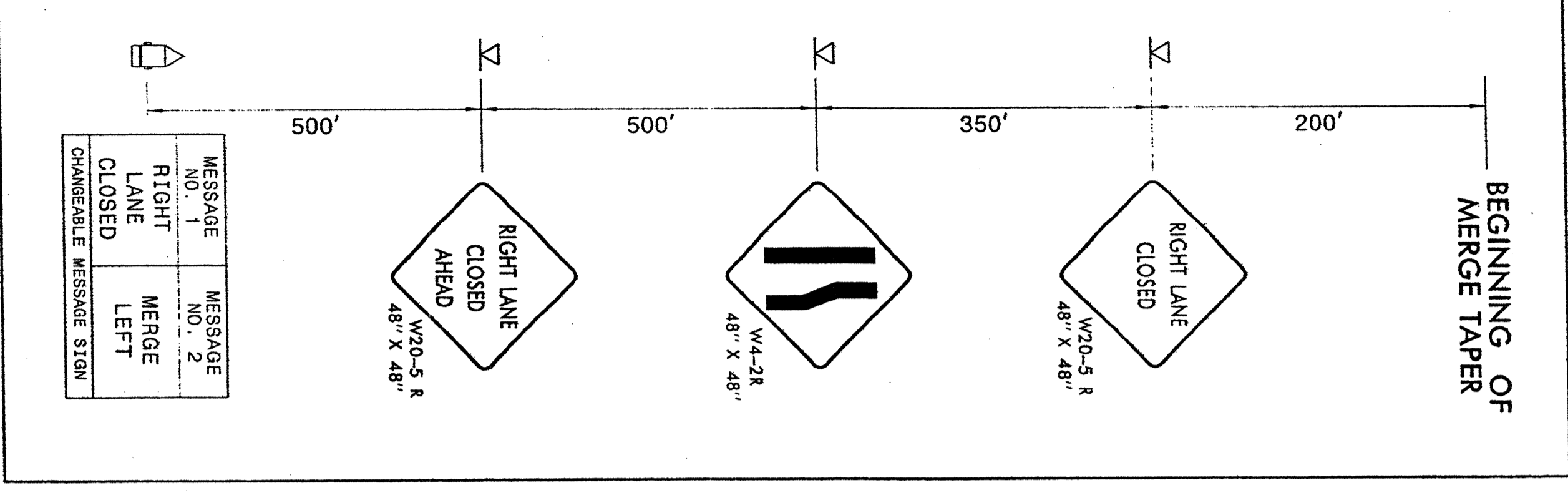

I:\28\2011\TrafficControl\BL-17BP.1.P.3 Ber-tie Martin\TC\Plan Sheets\BL-17BP.1.P.3.TC.TMP_06.MARTIN_07-RL.dgn
 gkarageorge

<p>Stantec Consulting Services Inc. 801 Jones Franklin Road Suite 300 Raleigh, NC 27606 Tel. (919) 851-8866 Fax. (919) 851-7024 www.stantec.com License No. F-0672</p>	APPROVED: _____ DATE: _____		<p>MARTIN CO. BRIDGE #7 US 64 EASTBOUND RIGHT LANE CLOSURE</p>
	SEAL <i>Timothy L. Watson</i> 1/26/11		

