

STATE	STATE PROJECT REFERENCE NO.	SHEET NO.	TOTAL SHEETS
N.C.	R-2237C	1	
STATE PROJ. NO.	F.A. PROJ. NO.	DESCRIPTION	
34402.1.1		PE	
34402.2.6		R / W	
34402.3.7		CONST.	

STATE OF NORTH CAROLINA  
DIVISION OF HIGHWAYS

# CALDWELL & WATAUGA COUNTIES

LOCATION: US 321 FROM SR 1500 (BLACKBERRY ROAD)  
TO US 221 AT BLOWING ROCK

TYPE OF WORK: GRADING, DRAINAGE, PAVING, CULVERT, RETAINING WALLS,  
AND SIGNALS

## Part 2 of 2

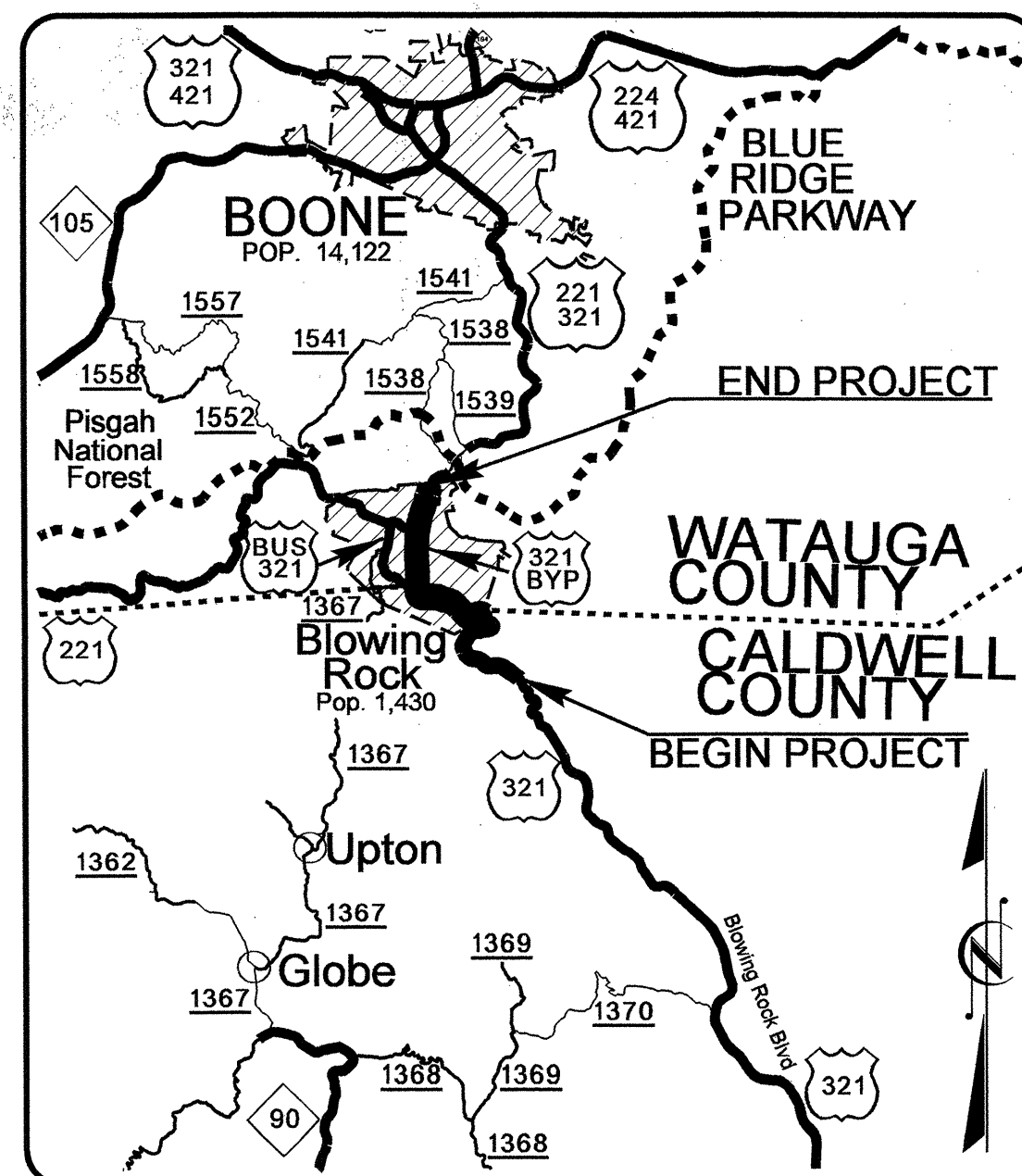

VICINITY MAP

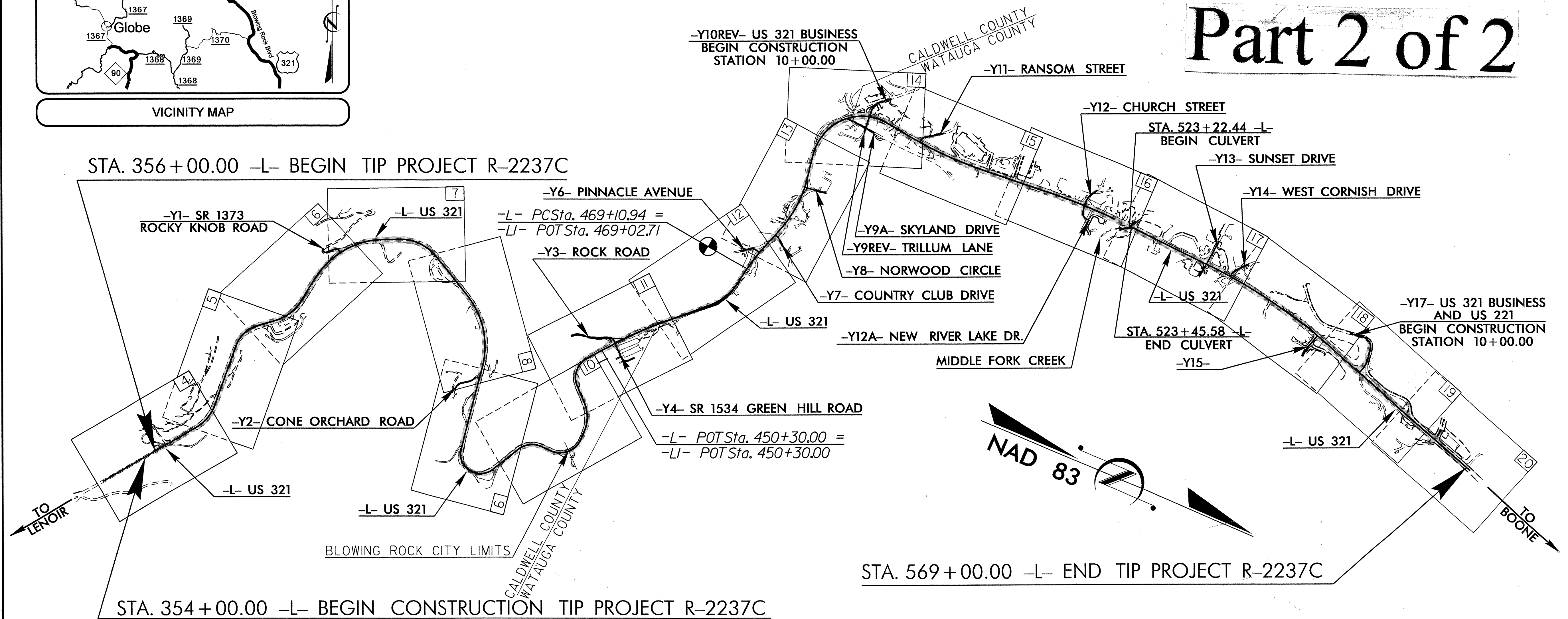

TIP PROJECT: R-2237C

CONTRACT: C202585

**GRAPHIC SCALES**

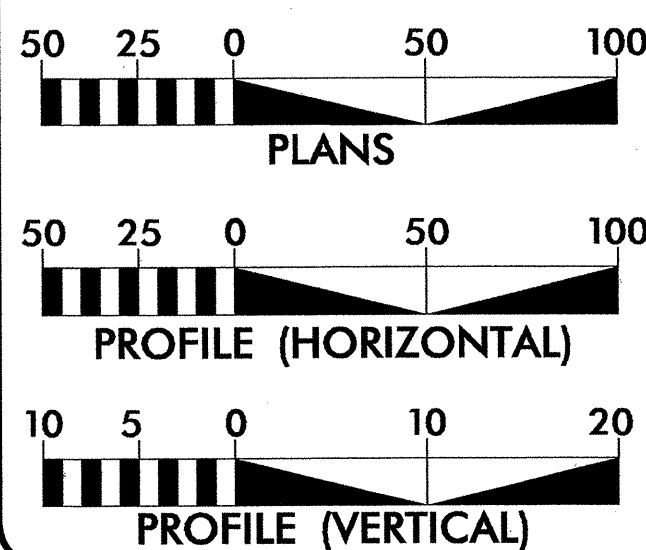

**DESIGN DATA**

ADT 2011 = 17,052  
ADT 2035 = 23,100  
DHV = 12 %  
D = 55 %  
T = 9 % \*  
V = 40 MPH  
\* TTST 3% + DUAL 6%  
STATEWIDE TIER  
FUNCTIONAL CLASSIFICATION  
ARTERIAL

**PROJECT LENGTH**

LENGTH ROADWAY TIP PROJECT R-2237C = 4.029 MILES  
LENGTH STRUCTURE TIP PROJECT R-2237C = 0.005 MILES  
TOTAL LENGTH OF TIP PROJECT R-2237C = 4.034 MILES

Prepared in the Office of:  
**DIVISION OF HIGHWAYS**  
1000 Birch Ridge Dr., Raleigh NC, 27610

2006 STANDARD SPECIFICATIONS

RIGHT OF WAY DATE:  
JUNE 27, 2008

LETTING DATE:  
NOVEMBER 15, 2011

G. E. BREW, PE  
PROJECT ENGINEER

W. T. BEST  
PROJECT DESIGN ENGINEER

HYDRAULICS ENGINEER

8-31-11  
Signature: *Marc T. Showen*  
NORTH CAROLINA PROFESSIONAL ENGINEER SEAL 20870  
MARC T. SHOWEN

ROADWAY DESIGN ENGINEER

8-19-11  
Signature: *Gregory E. Brew*  
NORTH CAROLINA PROFESSIONAL ENGINEER SEAL 18903  
GREGORY E. BREW

DIVISION OF HIGHWAYS  
STATE OF NORTH CAROLINA

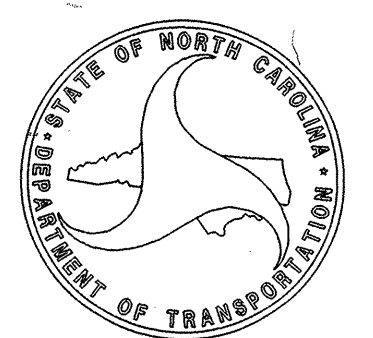

Signature: *Art McMillan*  
P.E.  
STATE HIGHWAY DESIGN ENGINEER

STATE OF NORTH CAROLINA  
DEPARTMENT OF TRANSPORTATION

PAVEMENT MARKING PLAN  
CALDWELL & WATAUGA COUNTIES

LOCATION: US 321 FROM SR 1500 (BLACKBERRY ROAD)  
TO US 221 AT BLOWING ROCK

TIP NO. R-2237C	SHEET NO. PMP-1
APPROVED: <i>Ayman Alqudwah</i>	
DATE: 3/16/11	
SEAL	
	

T.I.P.: R-2237C

**ROADWAY STANDARD DRAWING**

THE FOLLOWING ROADWAY STANDARDS AS APPEAR IN "ROADWAY STANDARD DRAWINGS" - PROJECT SERVICES UNIT - N.C. DEPARTMENT OF TRANSPORTATION - RALEIGH, N.C., DATED JULY 2006 ARE APPLICABLE TO THIS PROJECT AND BY REFERENCE HEREBY ARE CONSIDERED A PART OF THESE PLANS:

STD. NO.	TITLE
1205.01	PAVEMENT MARKINGS - LINE TYPES AND OFFSETS
1205.02	PAVEMENT MARKINGS - 2 LANE AND MULTILANE ROADWAYS
1205.04	PAVEMENT MARKINGS - INTERSECTIONS
1205.05	PAVEMENT MARKINGS - TURN LANES
1205.07	PAVEMENT MARKINGS - PEDESTRIAN CROSSINGS
1205.08	PAVEMENT MARKINGS - SYMBOL AND WORD MESSAGES
1205.09	PAVEMENT MARKINGS - PAINTED ISLANDS
1250.01	PAVEMENT MARKER SPACING
1253.01	SNOWFLOWABLE RAISED PAVEMENT MARKERS
1261.01	GUARDRAIL AND BARRIER DELINEATOR SPACING
1261.02	GUARDRAIL AND BARRIER DELINEATOR TYPES
1262.01	GUARDRAIL END DELINEATION

**GENERAL NOTES**

THE FOLLOWING GENERAL NOTES APPLY AT ALL TIMES FOR THE DURATION OF THE CONSTRUCTION PROJECT, EXCEPT WHEN OTHERWISE NOTED IN THE PLAN, OR DIRECTED BY THE ENGINEER.

- A) INSTALL PAVEMENT MARKINGS AND PAVEMENT MARKERS ON THE FINAL SURFACE AS FOLLOWS:

ROAD NAME	MARKING	MARKER
-L- US 321	POLYUREA & THERMOPLASTIC	SNOW PLOWABLE
-Y10- US 321 BUS.	POLYUREA & THERMOPLASTIC	SNOW PLOWABLE
-Y13- SUNSET DR.	POLYUREA & THERMOPLASTIC	SNOW PLOWABLE
-Y17- US 321 BUS./US 221	POLYUREA & THERMOPLASTIC	SNOW PLOWABLE
OTHER MARKED -Y- LINES	POLYUREA & THERMOPLASTIC	NONE

- B) TIE PROPOSED PAVEMENT MARKING LINES TO EXISTING PAVEMENT MARKING LINES.  
 C) REMOVE/REPLACE ANY CONFLICTING/DAMAGED PAVEMENT MARKINGS AND MARKERS.  
 D) PASSING ZONES WILL BE DETERMINED IN THE FIELD AND MUST BE APPROVED BY THE ENGINEER.  
 E) STOPBAR LOCATION AT NON-SIGNALIZED INTERSECTIONS MAY BE ADJUSTED AS DIRECTED BY THE ENGINEER.

**INDEX**

SHEET NO.	DESCRIPTION
PMP-1	PAVEMENT MARKING PLAN TITLE SHEET
PMP-2	PAVEMENT MARKING SCHEDULE
PMP-3-15	PAVEMENT MARKING DETAIL

PLAN PREPARED BY: N.C.D.O.T. SIGNING AND DELINEATION UNIT

AYMAN I. ALQUDWAH, P.E. SIGNING & DELINEATION REGIONAL ENGINEER

DERRICK BEARD SIGNING & DELINEATION PROJECT DESIGN ENGINEER

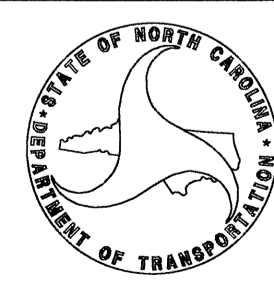

CONTRACT:

TIP NO.	SHEET NO.
R-2237C	PMP-2
APPROVED: <i>[Signature]</i>	
DATE: 3/11/11	
SEAL	
	

**PAVEMENT  
MARKING SCHEDULE**

SYMBOL      DESCRIPTION

MARKINGS

THERMOPLASTIC (24", 120 MILS)

T2      WHITE STOPBAR

POLYUREA (4") Highly Reflective Elements

- V8      2 FT. - 8 FT./SP WHITE MINISKIP
- VA      WHITE EDGELINE
- VB      YELLOW EDGELINE
- VC      10 FT. WHITE SKIP
- VD      2 FT. - 13 FT./SP WHITE MINISKIP
- VE      WHITE SOLID LANE LINE
- VG      2 FT. - 13 FT./SP YELLOW MINISKIP
- VI      YELLOW DOUBLE CENTER

POLYUREA (8") Highly Reflective Elements

VP      WHITE GORELINE

THERMOPLASTIC (8", 120 MILS)

TV      WHITE CROSSWALK LINE

THERMOPLASTIC (8", 90 MILS)

- TQ      WHITE DIAGONAL
- TT      YELLOW DIAGONAL

THERMOPLASTICPAVEMENT MARKING SYMBOLS (90 MILS)

- UA      LEFT TURN ARROW
- UB      RIGHT TURN ARROW
- UC      STRAIGHT ARROW
- UD      COMBO.STRAIGHT/LEFT
- UE      COMBO.STRAIGHT/RIGHT
- UN      24" YIELD LINE TRIANGLE

MARKERS

SNOWPLOWABLE RAISED PAVEMENT MARKERS

- ME      YELLOW & YELLOW
- MF      CRYSTAL & RED

**PAVEMENT MARKING DETAIL**

I7-MAR-2010 07:29  
 R:\Traffic\Signing\CADD\PMR\R-2237C.Sgn\_PMP-2.dgn  
 AT TE244736  
 dhbeard

TIP NO.	SHEET NO.
R-2237C	PMP-3
APPROVED: <i>[Signature]</i>	
DATE: 3/16/11	
SEAL	

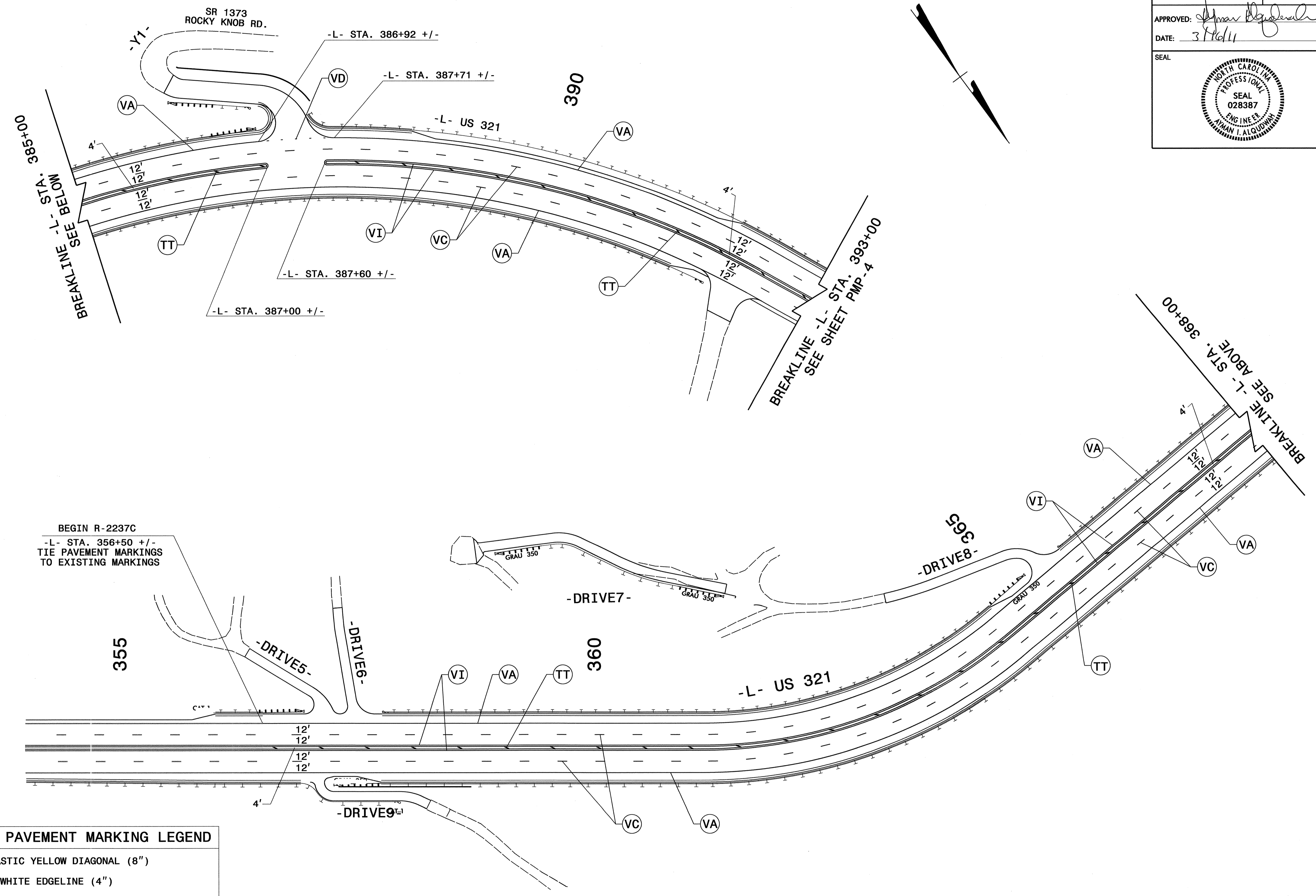

BEGIN R-2237C  
-L- STA. 356+50 +/-  
TIE PAVEMENT MARKINGS  
TO EXISTING MARKINGS

**SYMBOL & PAVEMENT MARKING LEGEND**

TT	THERMOPLASTIC YELLOW DIAGONAL (8")
VA	POLYUREA WHITE EDGELINE (4")
VC	POLYUREA 10' WHITE SKIP (4")
VD	POLYUREA 2 FT. 13 FT./SP. WHITE MINISKIP (4")
VI	POLYUREA YELLOW DOUBLE CENTER (4")

**PAVEMENT MARKING DETAIL**

I7-MAR-2011 13:40  
R:\Traffic\Signaling\CADD\PMR\R-2237C\_Sgn\_PMP\_3.dgn  
dnbeard AT 1E244736

TIP NO. R-2237C	SHEET NO. PMP-4
APPROVED: <i>[Signature]</i>	
DATE: 3/16/11	
SEAL	

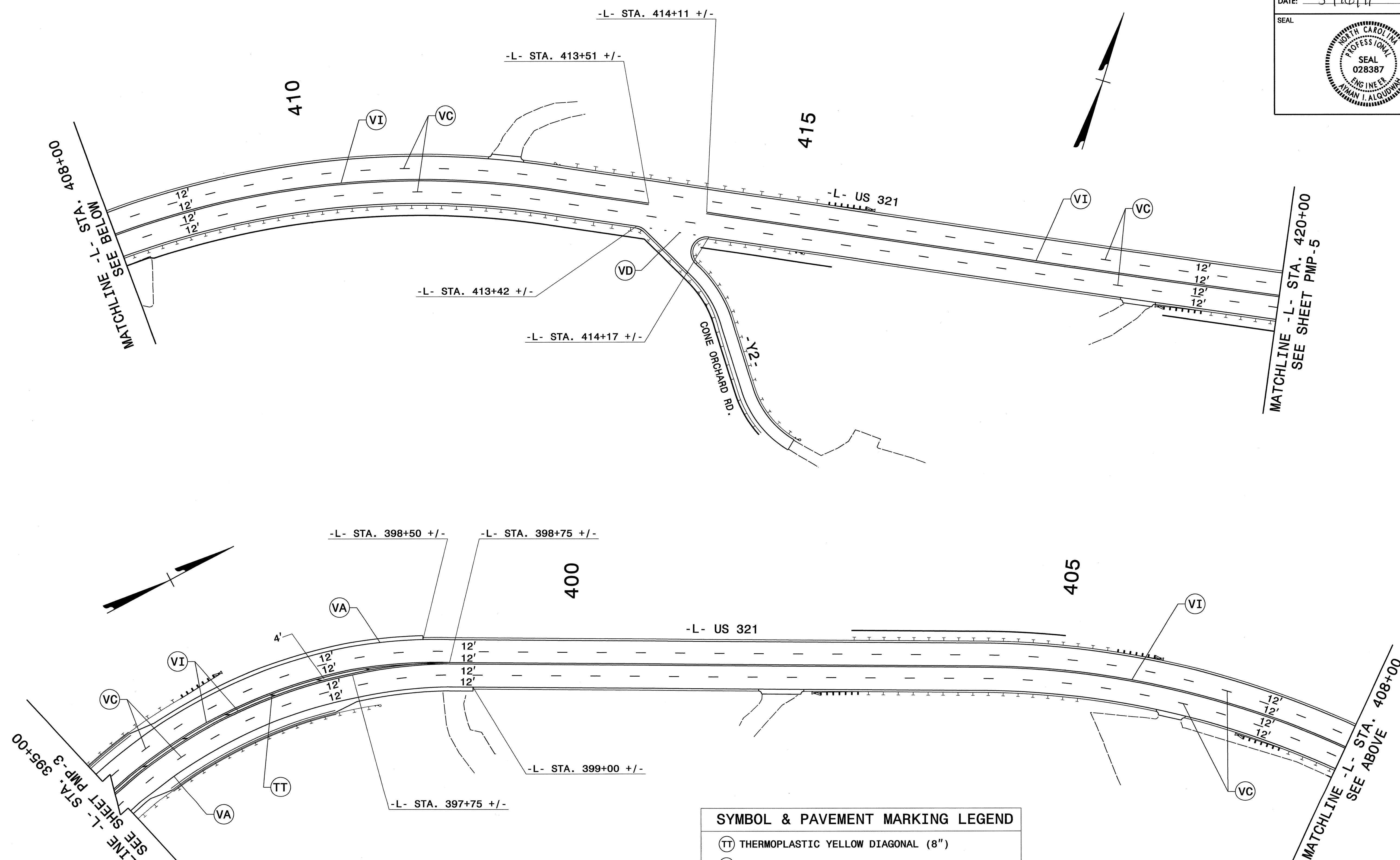

**SYMBOL & PAVEMENT MARKING LEGEND**

(TT)	THERMOPLASTIC YELLOW DIAGONAL (8")
(VA)	POLYUREA WHITE EDGELINE (4")
(VC)	POLYUREA 10' WHITE SKIP (4")
(VD)	POLYUREA 2 FT. 13 FT./SP. WHITE MINISKIP (4")
(VI)	POLYUREA YELLOW DOUBLE CENTER (4")

**PAVEMENT MARKING DETAIL**

I7-MAR-2011 13:41  
 R:\Traffic\Signing\CADD\PMR-2237C\_Sgn\_PMP-4.dgn  
 dbbeard AT 1E244736

TIP NO.	SHEET NO.
R-2237C	PMP-5
APPROVED: <i>[Signature]</i>	
DATE: 3/16/11	
SEAL	
	

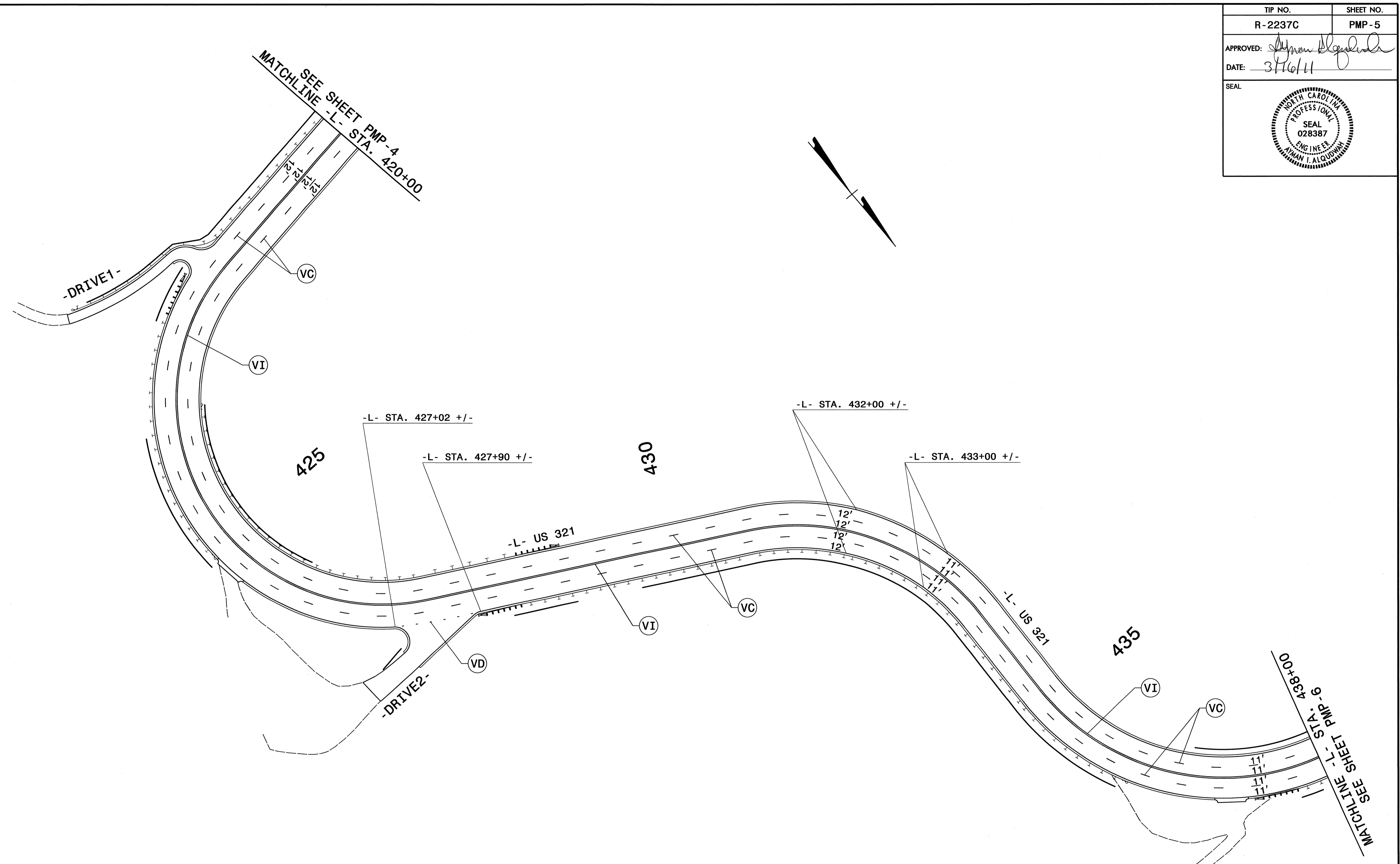

**SYMBOL & PAVEMENT MARKING LEGEND**

(VC)	POLYUREA 10' WHITE SKIP (4")
(VD)	POLYUREA 2 FT. 13 FT./SP. WHITE MINISKIP (4")
(VI)	POLYUREA YELLOW DOUBLE CENTER (4")

**PAVEMENT MARKING DETAIL**







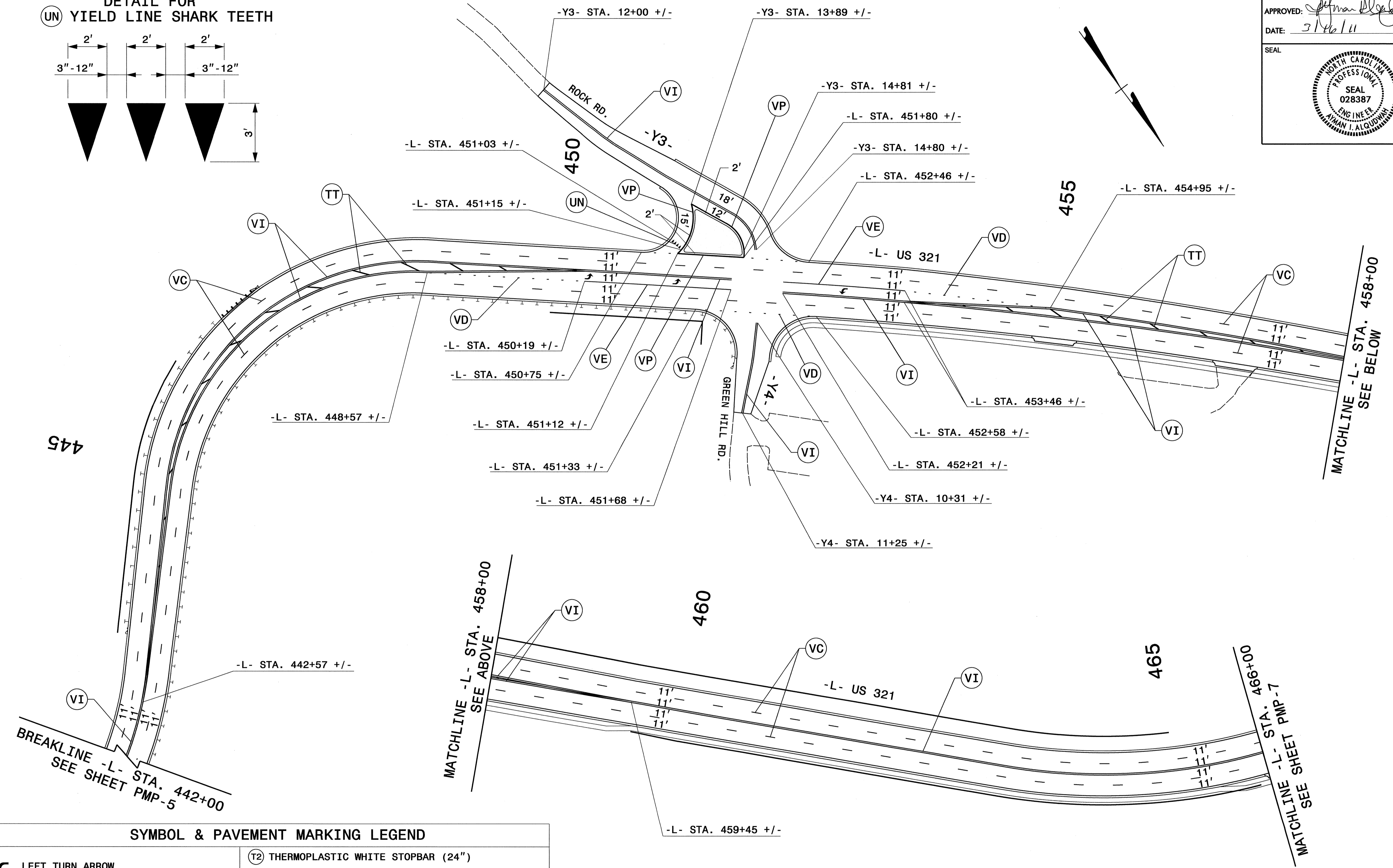
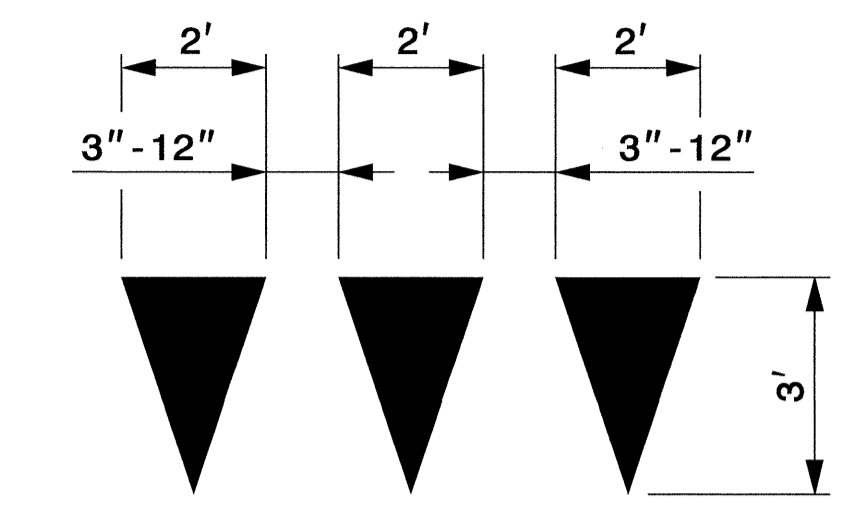

I:\MAR-2011\07132  
 R:\Tr\offic\Signing\CADD\PMR\R-2237C\_Sgn\_PMP-5.dgn  
 dbbeard AT 12/24/10

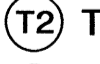
TIP NO. R-2237C	SHEET NO. PMP-6
APPROVED: <i>[Signature]</i>	
DATE: 3/16/11	
SEAL	
	

**DETAIL FOR YIELD LINE SHARK TEETH**



**SYMBOL & PAVEMENT MARKING LEGEND**

	LEFT TURN ARROW		THERMOPLASTIC WHITE STOPBAR (24")
	THERMOPLASTIC YIELD LINE TRIANGLE		THERMOPLASTIC YELLOW DIAGONAL (8")
			POLYUREA 10' WHITE SKIP (4")
			POLYUREA 2 FT. 13 FT./SP. WHITE MINISKIP (4")
			POLYUREA WHITE LANE LINE (4")
			POLYUREA YELLOW DOUBLE CENTER (4")
			POLYUREA WHITE GORELINE (8")

**PAVEMENT MARKING DETAIL**

I7-MAR-2010 07:33  
 R:\Tr-office\Signing\CADD\NMP\AR-2237C\_Sgn\_PMP-6.dgn  
 dbeard AT TE244736

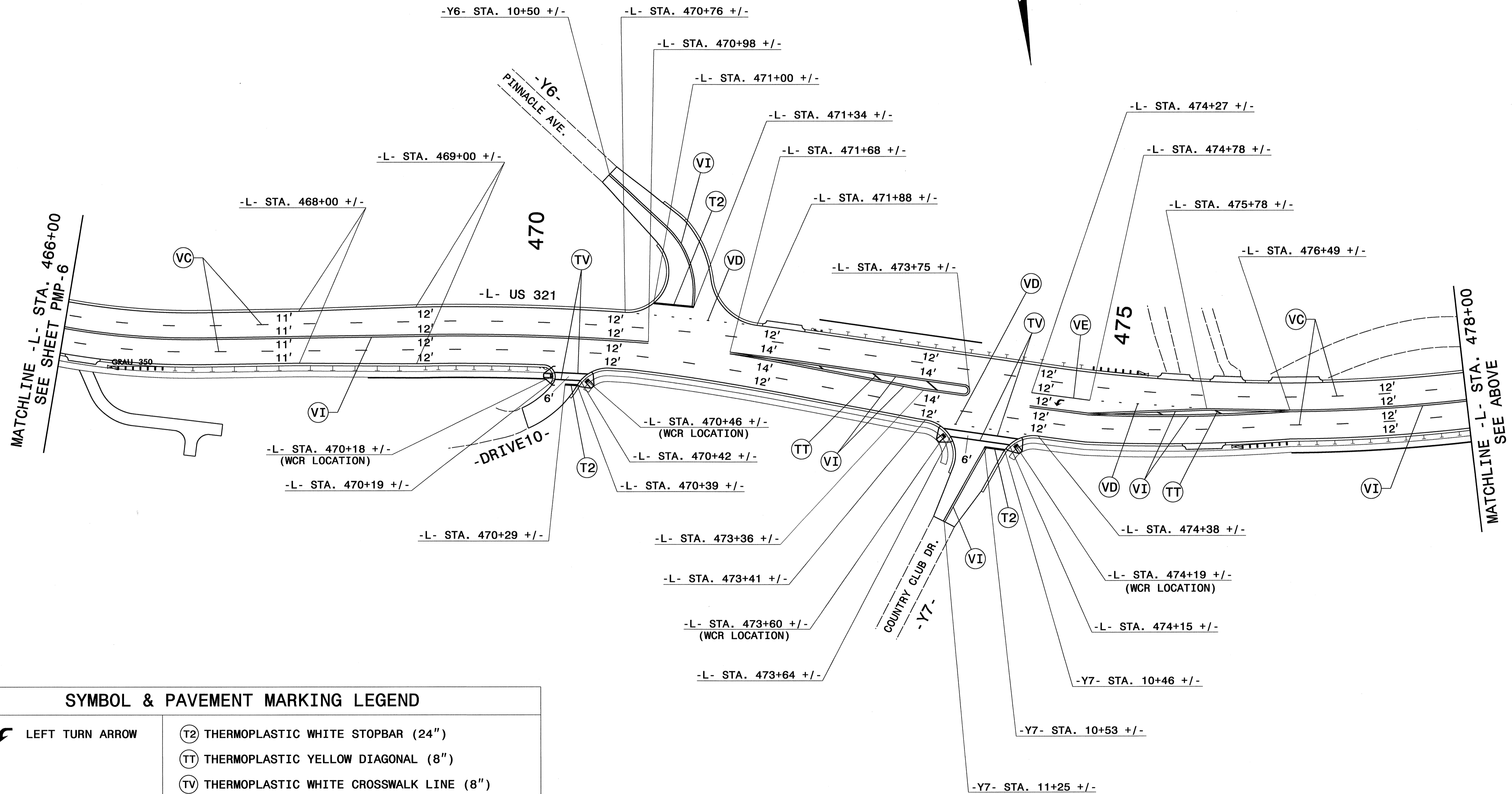

**SYMBOL & PAVEMENT MARKING LEGEND**

← LEFT TURN ARROW

- (T2) THERMOPLASTIC WHITE STOPBAR (24")
- (TT) THERMOPLASTIC YELLOW DIAGONAL (8")
- (TV) THERMOPLASTIC WHITE CROSSWALK LINE (8")
- (VC) POLYUREA 10' WHITE SKIP (4")
- (VD) POLYUREA 2 FT. 13 FT./SP. WHITE MINISKIP (4")
- (VE) POLYUREA WHITE LANE LINE (4")
- (VI) POLYUREA YELLOW DOUBLE CENTER (4")

**PAVEMENT MARKING DETAIL**



TIP NO.	SHEET NO.
R-2237C	PMP-8
APPROVED: <i>[Signature]</i>	
DATE: 3/16/11	
SEAL	

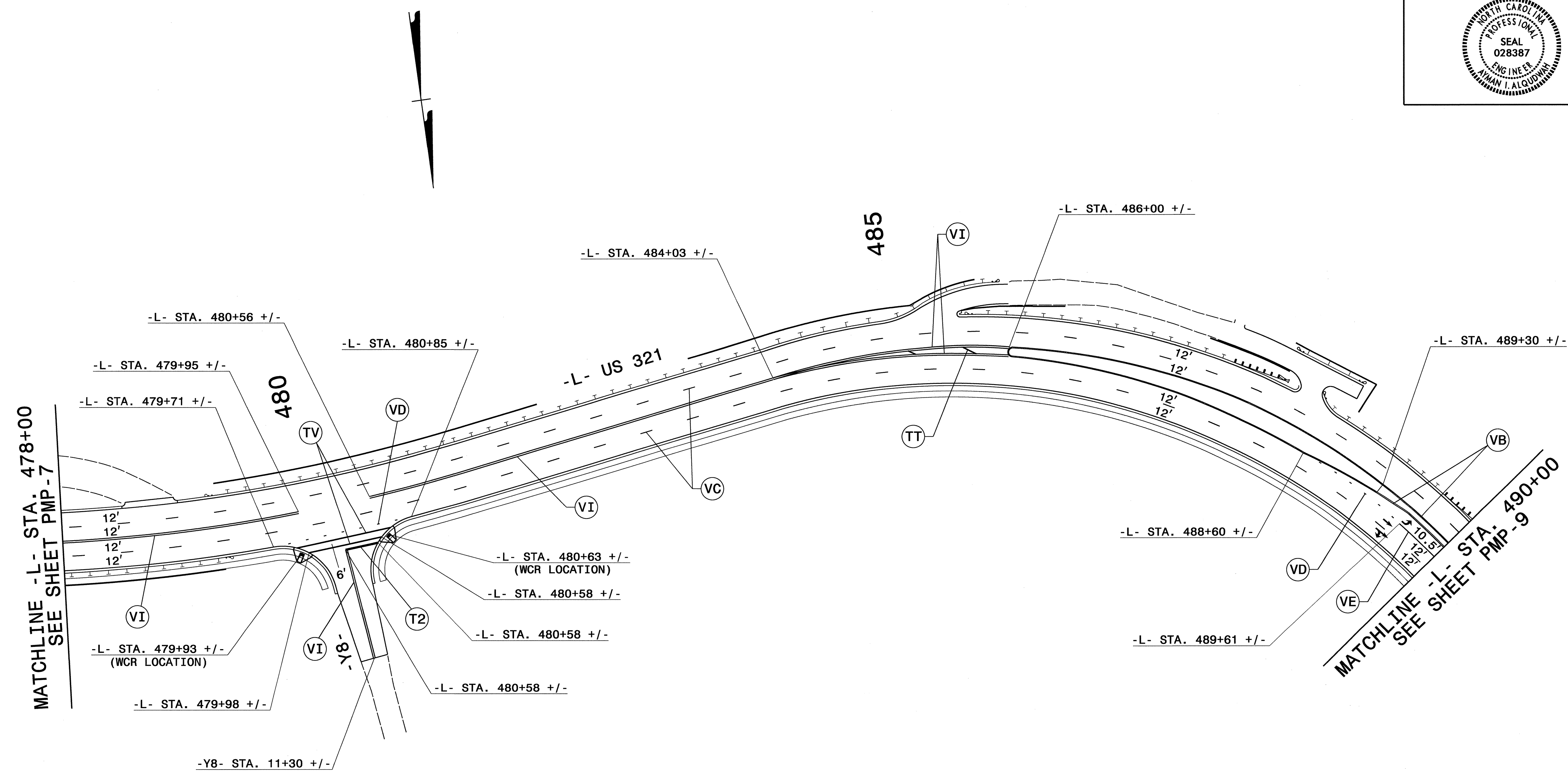

**SYMBOL & PAVEMENT MARKING LEGEND**

	LEFT TURN ARROW		THERMOPLASTIC YELLOW DIAGONAL (8")
	STRAIGHT ARROW		THERMOPLASTIC WHITE CROSSWALK LINE (8")
	COMBO STRAIGHT/RIGHT ARROW		POLYUREA YELLOW EDGELINE (4")
			POLYUREA 10' WHITE SKIP (4")
			POLYUREA 2 FT. 13 FT./SP. WHITE MINISKIP (4")
			POLYUREA WHITE SOLID LANE LINE (4")
			POLYUREA YELLOW DOUBLE CENTER (4")

**PAVEMENT MARKING DETAIL**

IT-MAR-2011 07:38  
 R:\T\office\Signing\CADD\PMR\R-2237C\_Sgn\_PMP-8.dgn  
 dhbeard AT 12/24/10

TIP NO. R-2237C	SHEET NO. PMP-9
APPROVED: <i>[Signature]</i>	
DATE: 3/16/11	
SEAL	

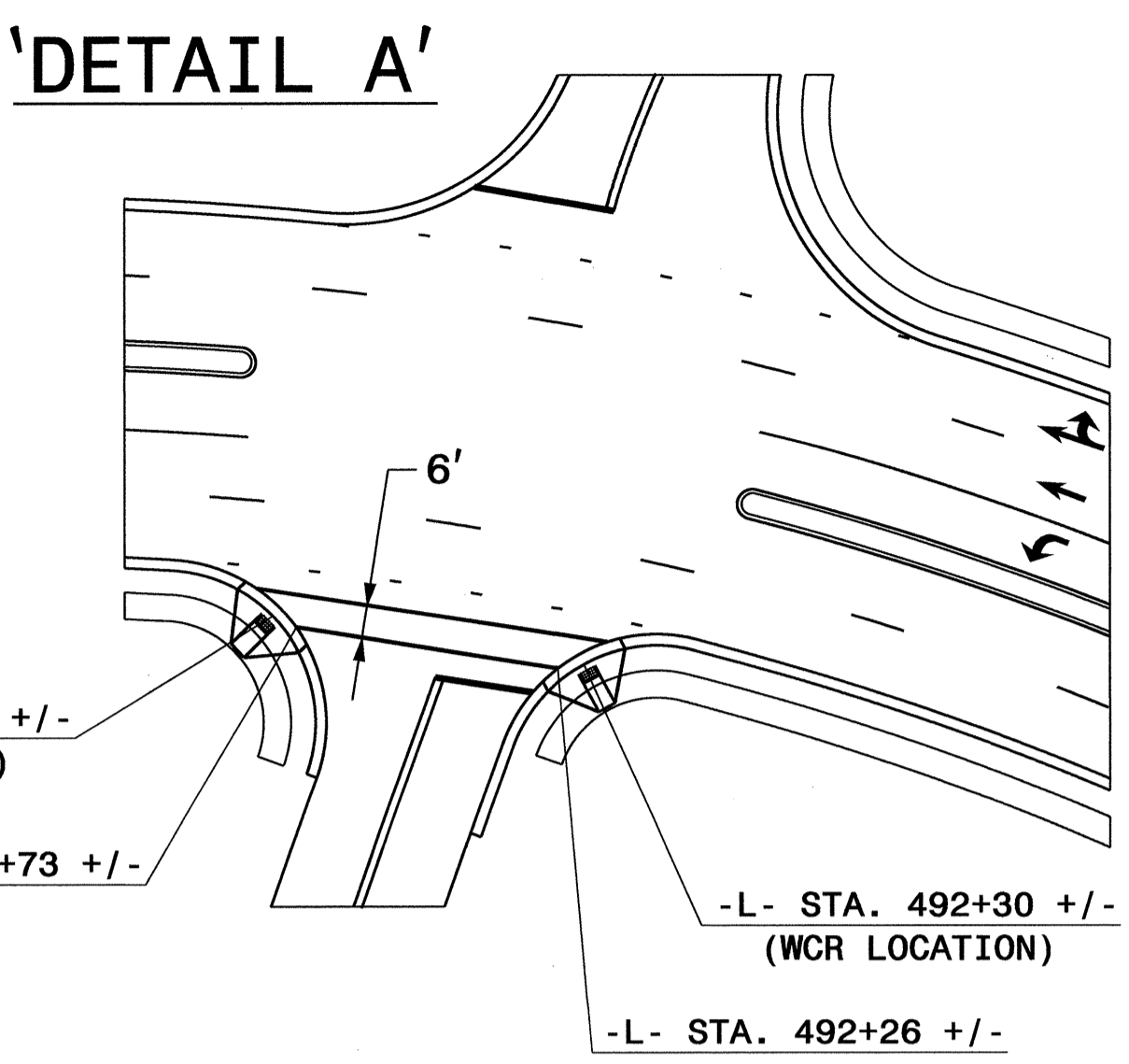
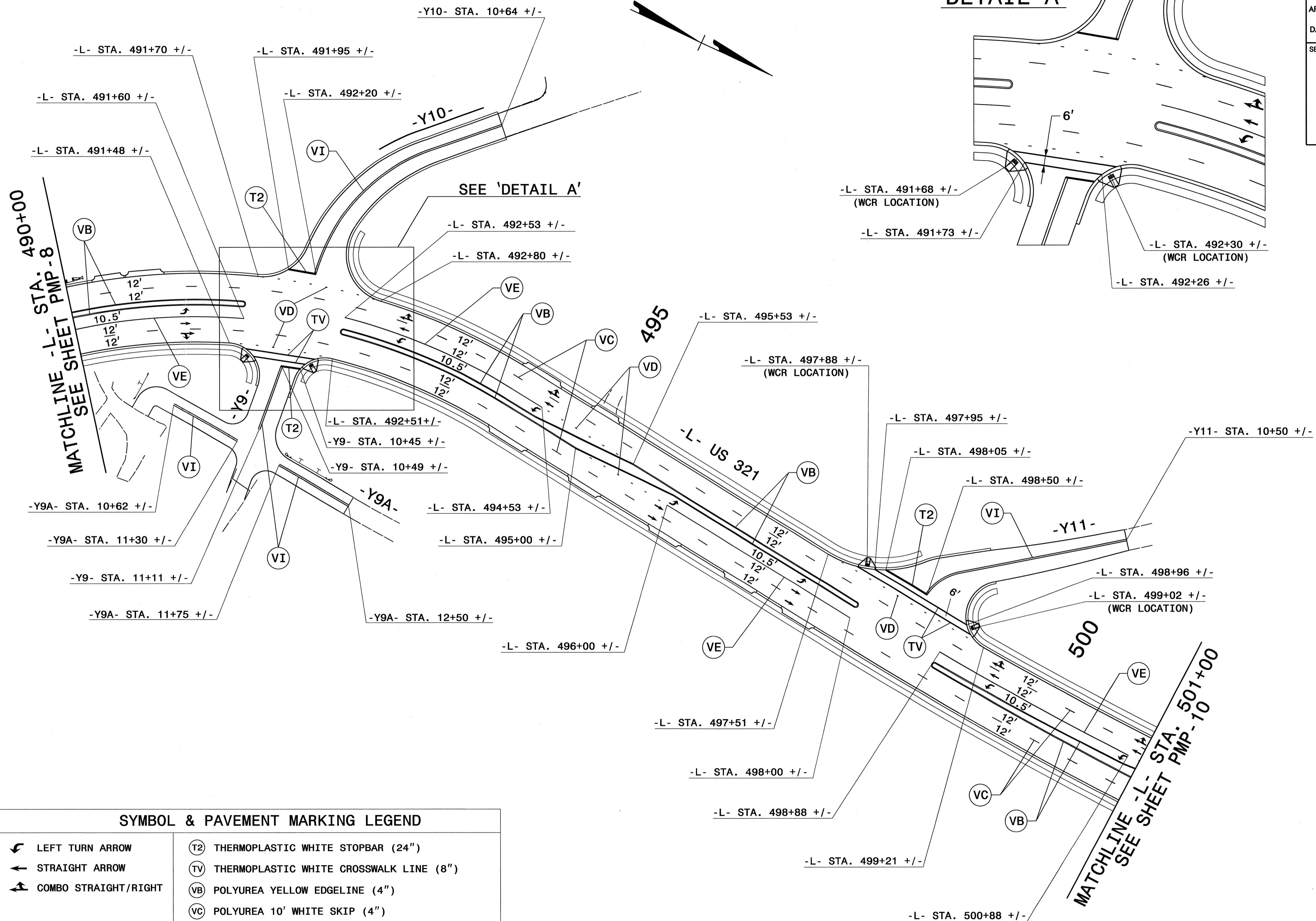

**SYMBOL & PAVEMENT MARKING LEGEND**

	LEFT TURN ARROW		THERMOPLASTIC WHITE STOPBAR (24")
	STRAIGHT ARROW		THERMOPLASTIC WHITE CROSSWALK LINE (8")
	COMBO STRAIGHT/RIGHT		POLYUREA YELLOW EDGELINE (4")
			POLYUREA 10' WHITE SKIP (4")
			POLYUREA 2 FT. 13 FT./SP. WHITE MINISKIP (4")
			POLYUREA WHITE SOLID LANE LINE (4")
			POLYUREA YELLOW DOUBLE CENTER (4")

**PAVEMENT MARKING DETAIL**

I7-MAR-2011 07:33  
 R:\Traffic\Signing\CADD\PMR\R-2237C\_Sgn\_PMP\_9.dgn  
 dbbeard

TIP NO. R-2237C	SHEET NO. PMP-10
APPROVED: <i>[Signature]</i>	
DATE: 3/16/11	
SEAL	

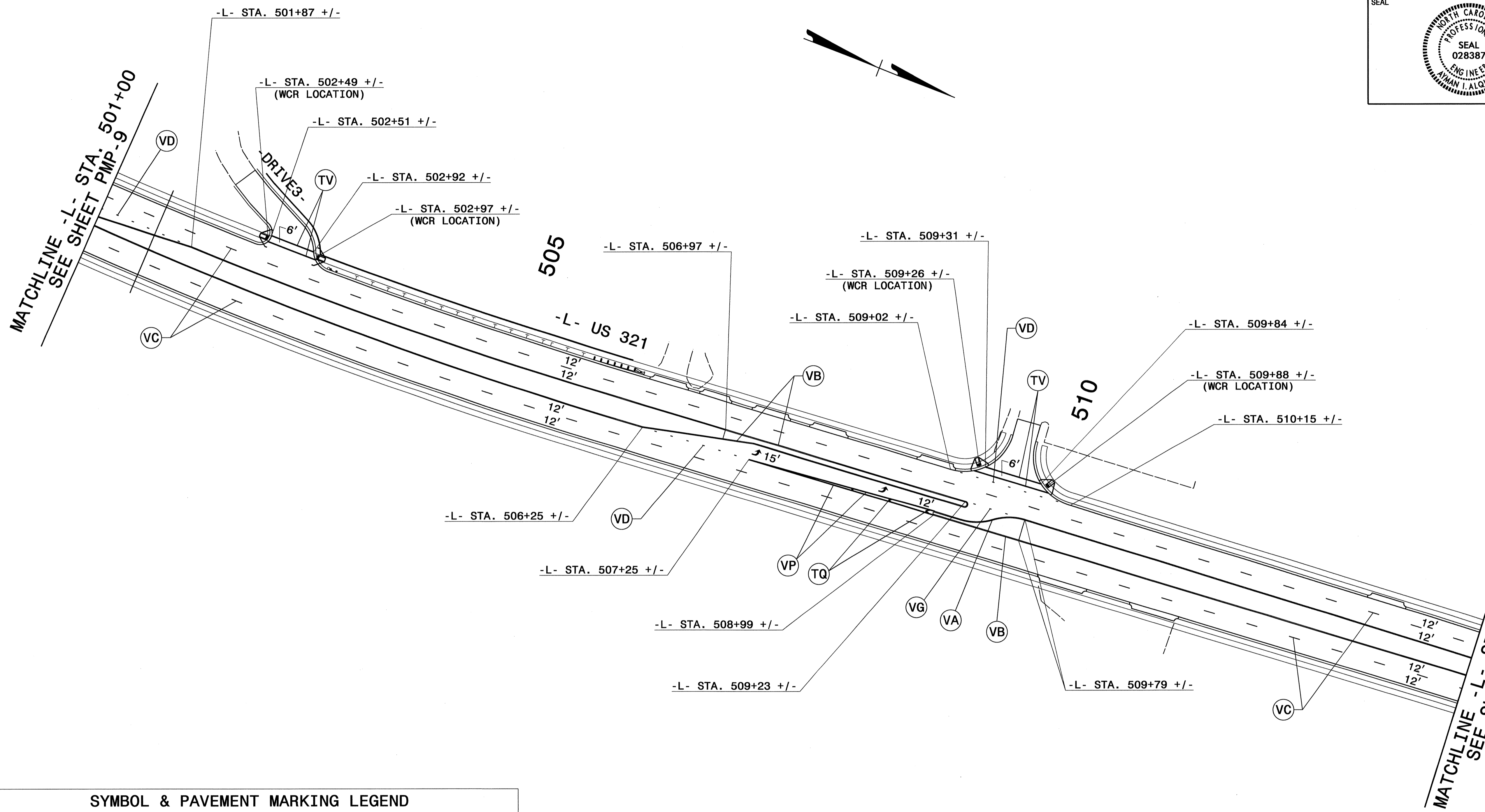

**SYMBOL & PAVEMENT MARKING LEGEND**

LEFT TURN ARROW	(TQ) THERMOPLASTIC WHITE DIAGONAL (8")
	(TV) THERMOPLASTIC WHITE CROSSWALK LINE (8")
	(VA) POLYUREA WHITE EDGELINE (4")
	(VB) POLYUREA YELLOW EDGELINE (4")
	(VC) POLYUREA 10' WHITE SKIP (4")
	(VD) POLYUREA 2 FT. 13 FT./SP. WHITE MINISKIP (4")
	(VG) POLYUREA 2 FT. 13FT./SP. YELLOW MINISKIP (4")
	(VP) POLYUREA WHITE GORELINE (8")

**PAVEMENT MARKING DETAIL**

I7-MAR-2011 07:40  
 R:\Traffic\Signing\CADD\PMR\R-2237C\_Sgn\_PMP\_10.dgn  
 dnbeard AT 112244736

TIP NO. R-2237C	SHEET NO. PMP-11
APPROVED: <i>[Signature]</i>	
DATE: 3/11/11	
SEAL	

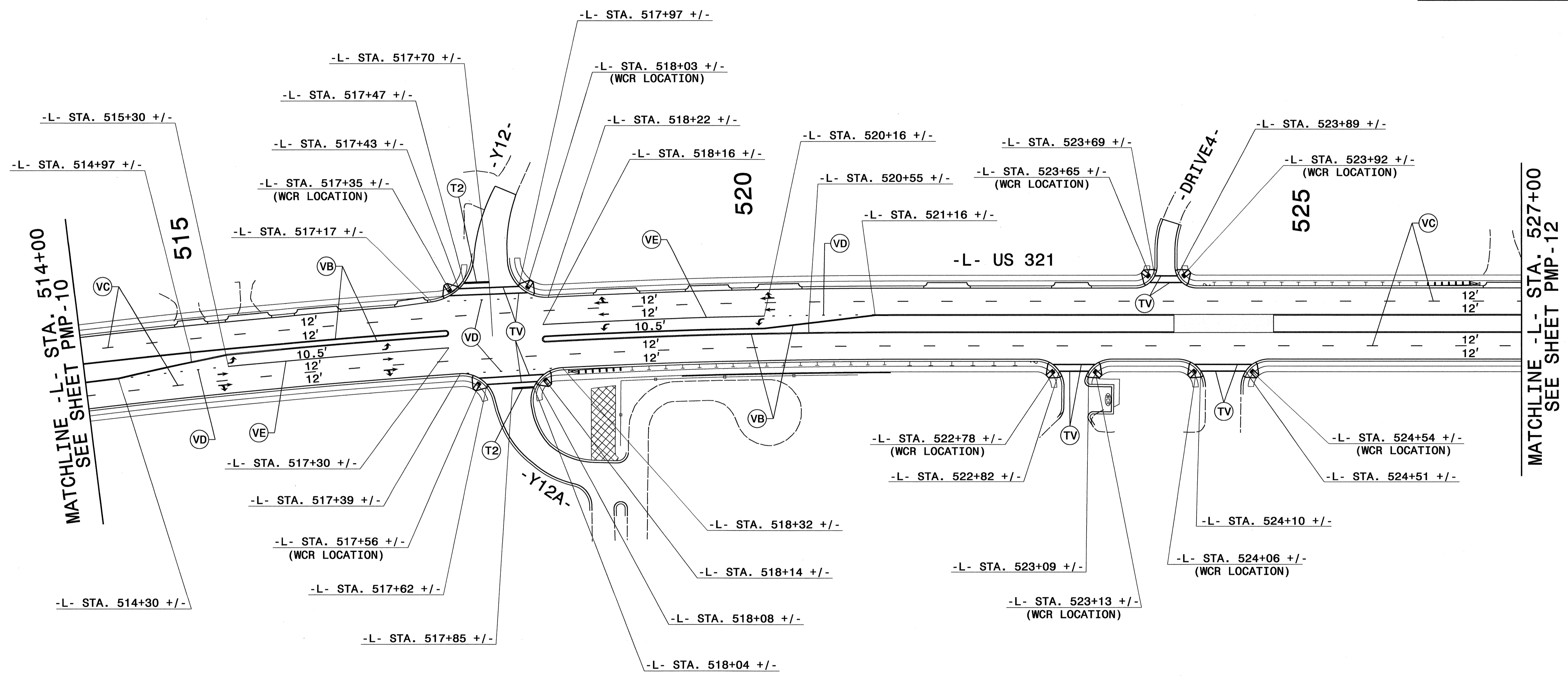

**SYMBOL & PAVEMENT MARKING LEGEND**

	LEFT TURN ARROW		THERMOPLASTIC WHITE STOPBAR (24")
	STRAIGHT ARROW		THERMOPLASTIC WHITE CROSSWALK LINE (8")
	COMBO STRAIGHT/RIGHT		POLYUREA YELLOW EDGELINE (4")
			POLYUREA 10' WHITE SKIP (4")
			POLYUREA 2 FT. 13 FT./SP. WHITE MINISKIP (4")
			POLYUREA WHITE SOLID LANE LINE (4")

**PAVEMENT MARKING DETAIL**

I7-MAR-2011 11:48  
 R:\Traffic\Signing\CADD\NMP\AR-2237C\_Sgn\_PMP\_11.dgn  
 dbbeard AT 1E244736

TIP NO.	SHEET NO.
R-2237C	PMP-12
APPROVED: <i>[Signature]</i>	
DATE: 3/16/11	
SEAL	

### SYMBOL & PAVEMENT MARKING LEGEND

	LEFT TURN ARROW	(T2)	THERMOPLASTIC WHITE STOPBAR (24")
	STRAIGHT ARROW	(TV)	THERMOPLASTIC WHITE CROSSWALK LINE (8")
	COMBO STRAIGHT/RIGHT	(VA)	POLYUREA WHITE EDGELINE (4")
		(VB)	POLYUREA YELLOW EDGELINE (4")
		(VC)	POLYUREA 10' WHITE SKIP (4")
		(VD)	POLYUREA 2 FT. 13 FT./SP. WHITE MINISKIP (4")
		(VE)	POLYUREA WHITE SOLID LANE LINE (4")
		(VI)	POLYUREA YELLOW DOUBLE CENTER (4")

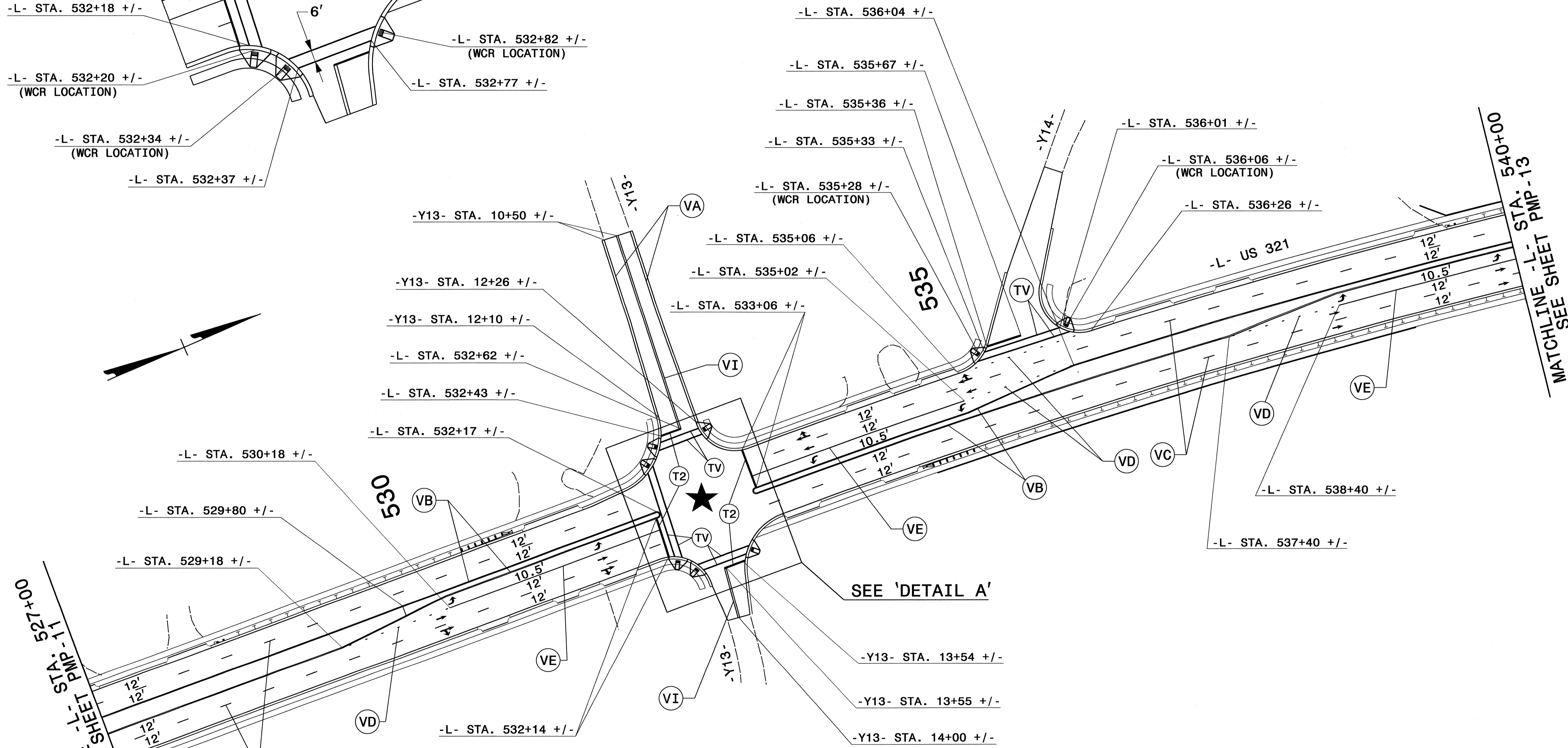
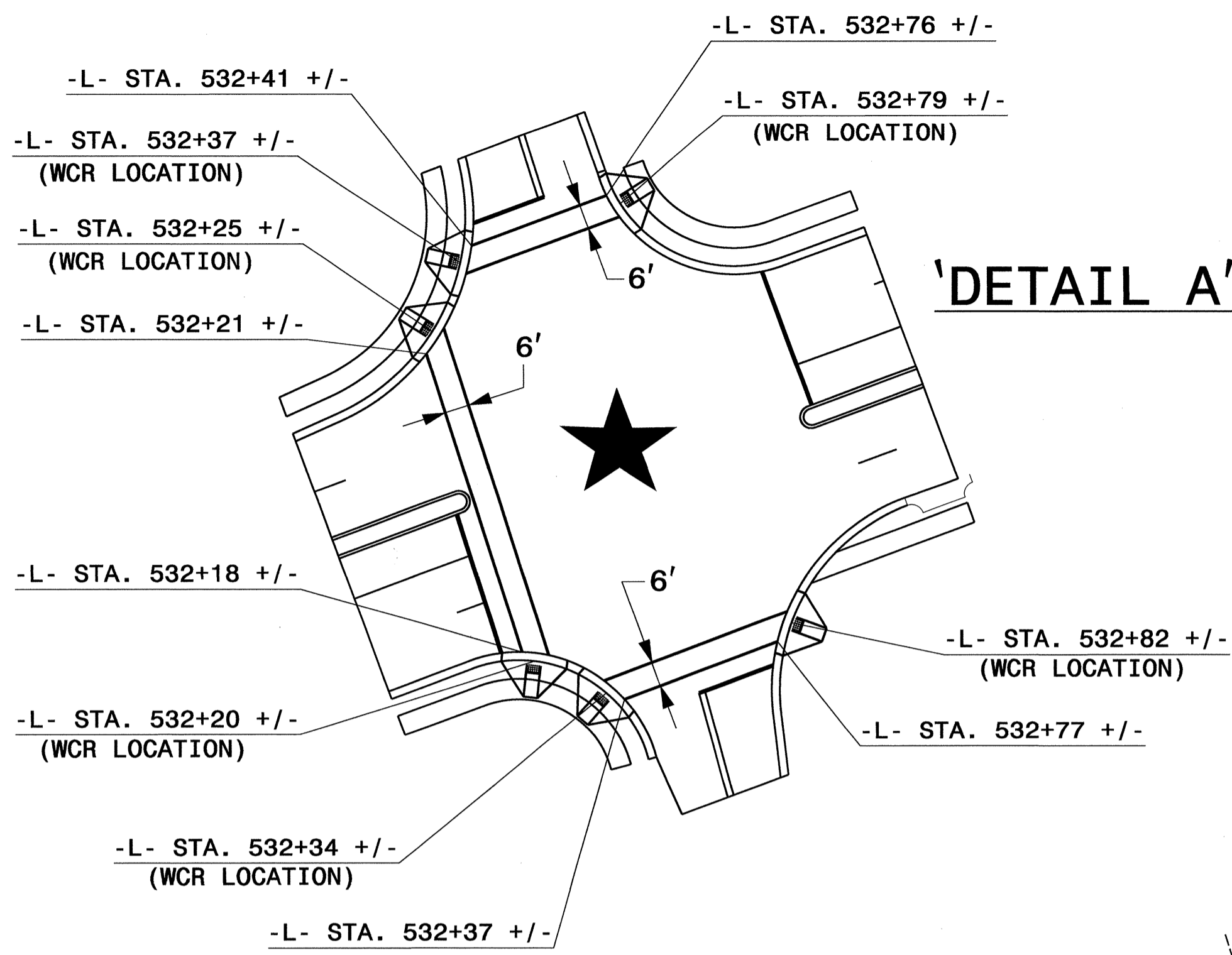

**PAVEMENT MARKING DETAIL**

I7-MAR-2011 11:49  
 R:\T\office\Signing\CADD\PM\AR-2237C\_Sgn\_PMP\_12.dgn  
 dbbeard AT TE244736

TIP NO.	SHEET NO.
R-2237C	PMP-13
APPROVED: <i>[Signature]</i>	
DATE: 3/16/11	
SEAL	

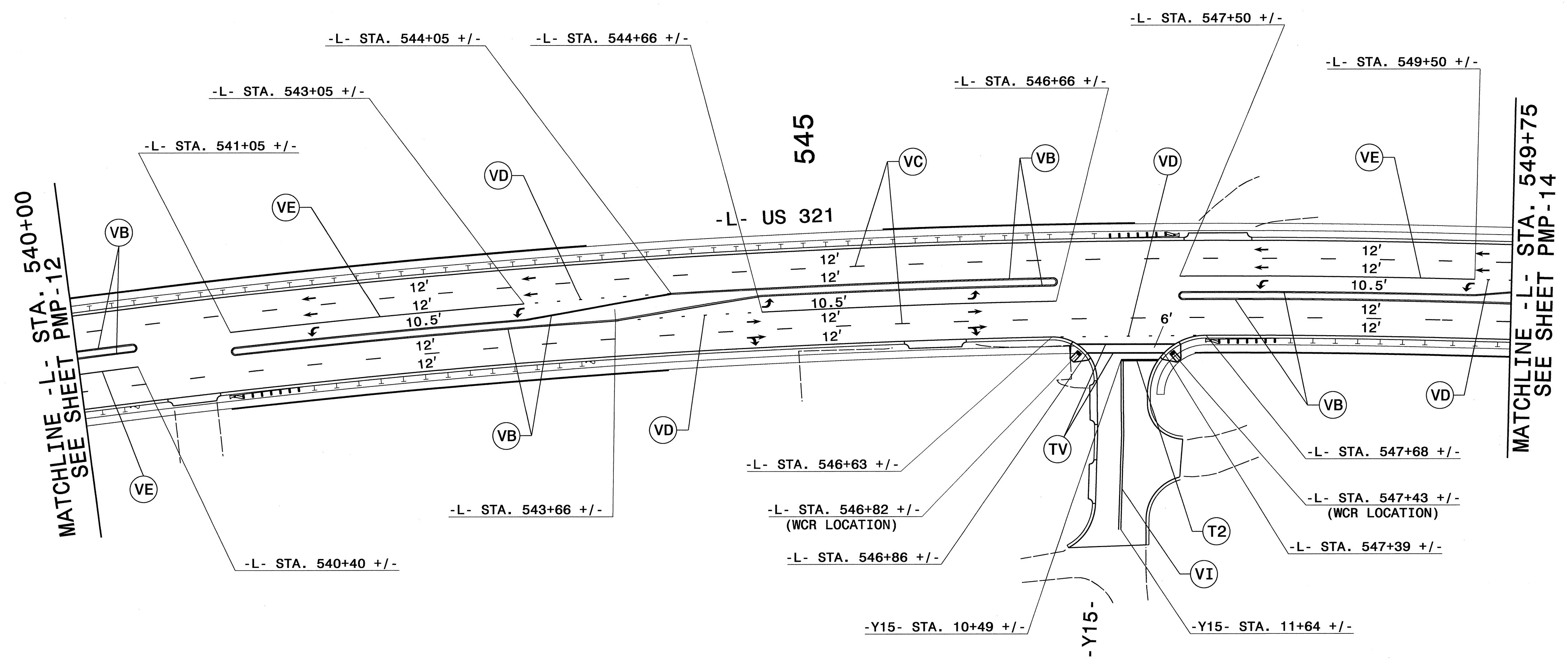





SYMBOL & PAVEMENT MARKING LEGEND	
	LEFT TURN ARROW
	STRAIGHT ARROW
	COMBO STRAIGHT/RIGHT
	THERMOPLASTIC WHITE STOPBAR (24")
	THERMOPLASTIC WHITE CROSSWALK LINE (8")
	POLYUREA YELLOW EDGELINE (4")
	POLYUREA 10' WHITE SKIP (4")
	POLYUREA 2 FT. 13 FT./SP. WHITE MINISKIP (4")
	POLYUREA WHITE SOLID LANE LINE (4")
	POLYUREA YELLOW DOUBLE CENTER (4")

**PAVEMENT MARKING DETAIL**

I7-MAR-2011 08:05  
 R:\Traffic\Signaling\CADD\PMR\R-2237C\_Sgn\_PMP\_13.dgn  
 dnbeard AT 11244736

TIP NO. R-2237C	SHEET NO. PMP-14
APPROVED: <i>[Signature]</i>	
DATE: 3/16/11	
SEAL	
	

**SYMBOL & PAVEMENT MARKING LEGEND**

- |  |  |
|--|--|
|  LEFT TURN ARROW      | (T2) THERMOPLASTIC WHITE STOPBAR (24")             |
|  RIGHT TURN ARROW     | (TT) THERMOPLASTIC YELLOW DIAGONAL (8")            |
|  STRAIGHT ARROW       | (TV) THERMOPLASTIC WHITE CROSSWALK LINE (8")       |
|  COMBO STRAIGHT/LEFT  | (V8) POLYUREA 2 FT. 8FT./SP. WHITE MINISKIP (4")   |
|  COMBO STRAIGHT/RIGHT | (VA) POLYUREA WHITE EDGELINE (4")                  |
|  | (VB) POLYUREA YELLOW EDGELINE (4")                 |
|  | (VC) POLYUREA 10' WHITE SKIP (4")                  |
|  | (VD) POLYUREA 2 FT. 13 FT./SP. WHITE MINISKIP (4") |
|  | (VE) POLYUREA WHITE SOLID LANE LINE (4")           |
|  | (VI) POLYUREA YELLOW DOUBLE CENTER (4")            |

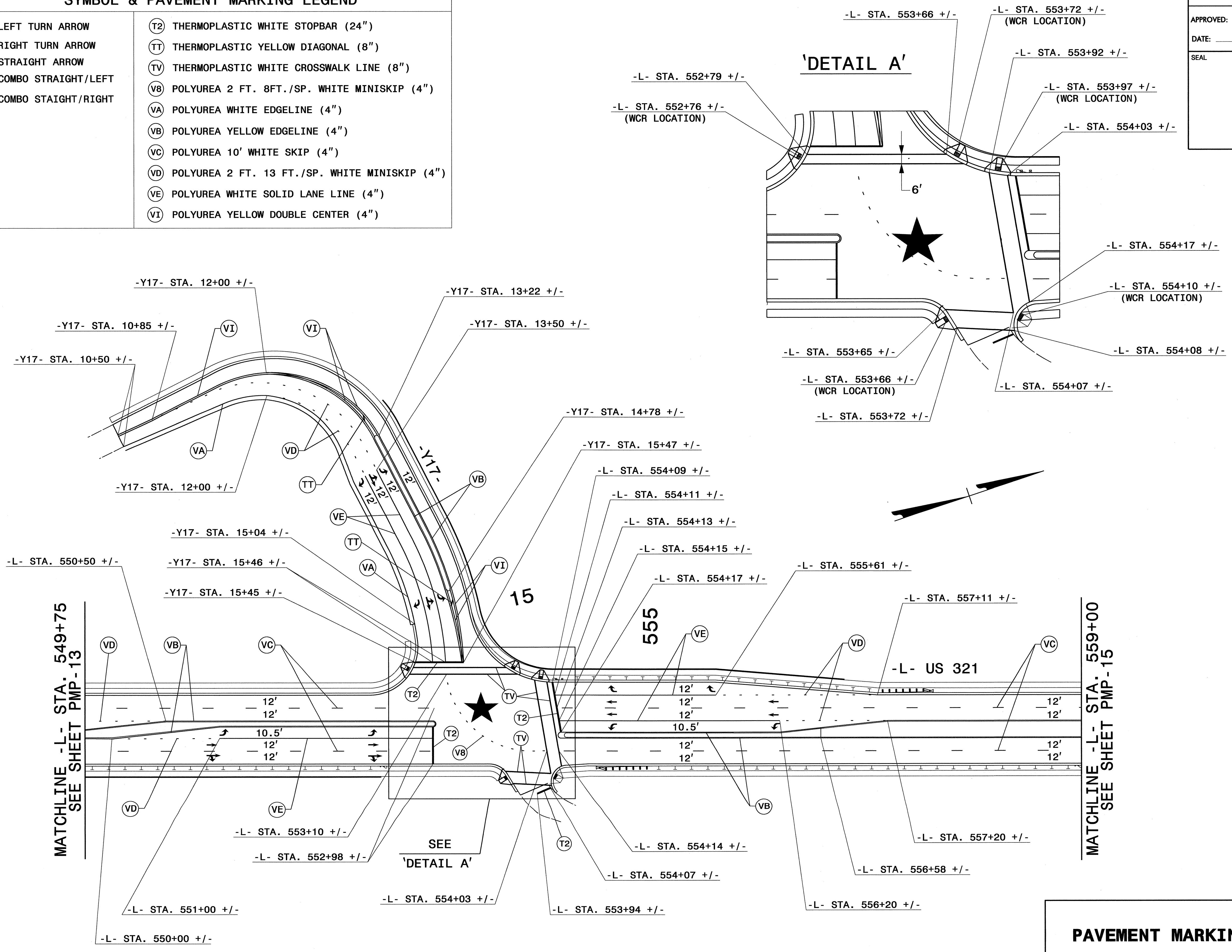

**'DETAIL A'**

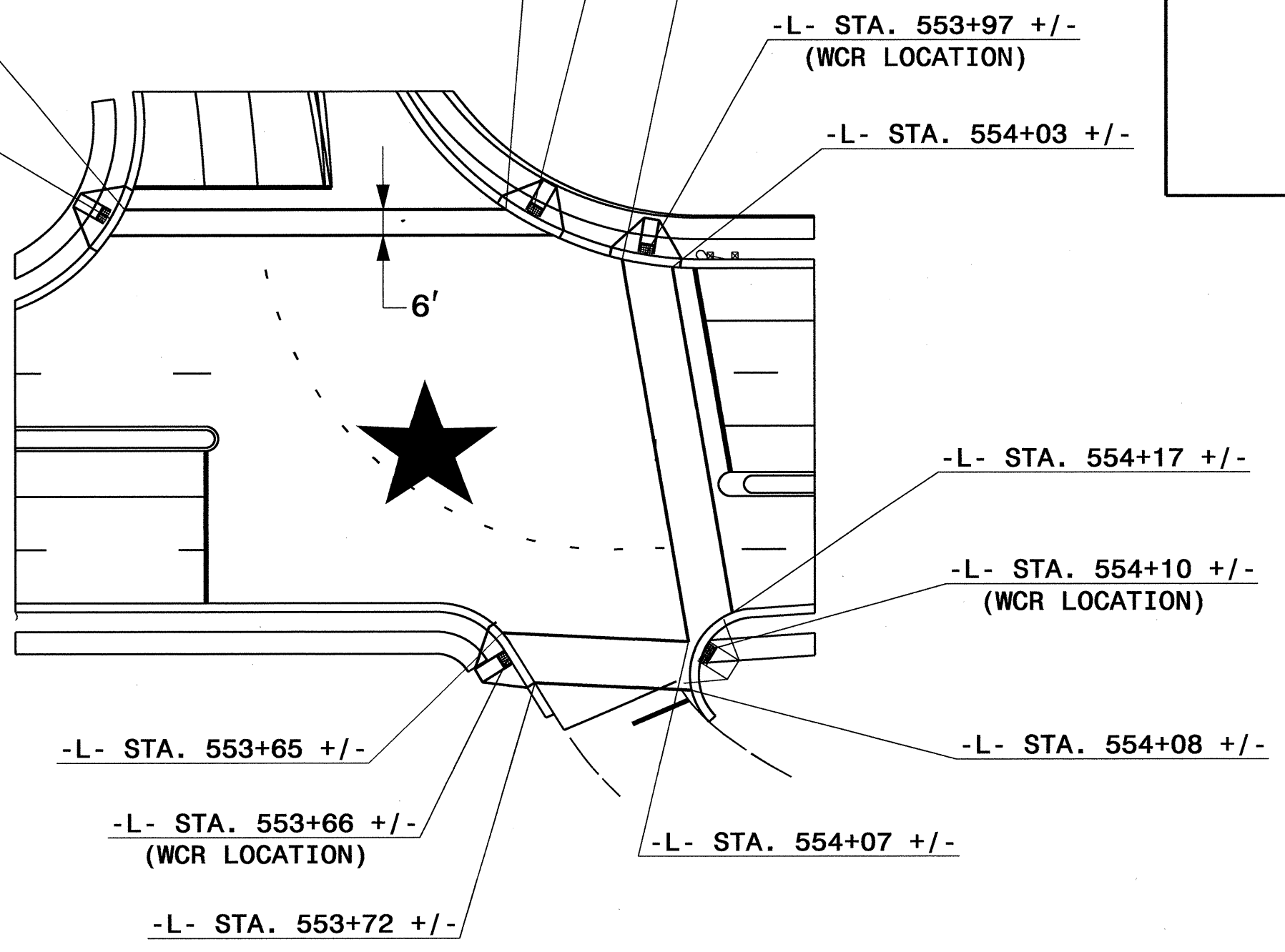

I7-MAR-2011 11:50  
 R:\Tr-office\Signing\CADD\PMR\R-2237C\_Sgn\_PMP-14.dgn  
 gibeard AT TE244736

**PAVEMENT MARKING DETAIL**

TIP NO.	SHEET NO.
R-2237C	PMP-15
APPROVED: <i>[Signature]</i>	
DATE: 3/16/11	
SEAL	

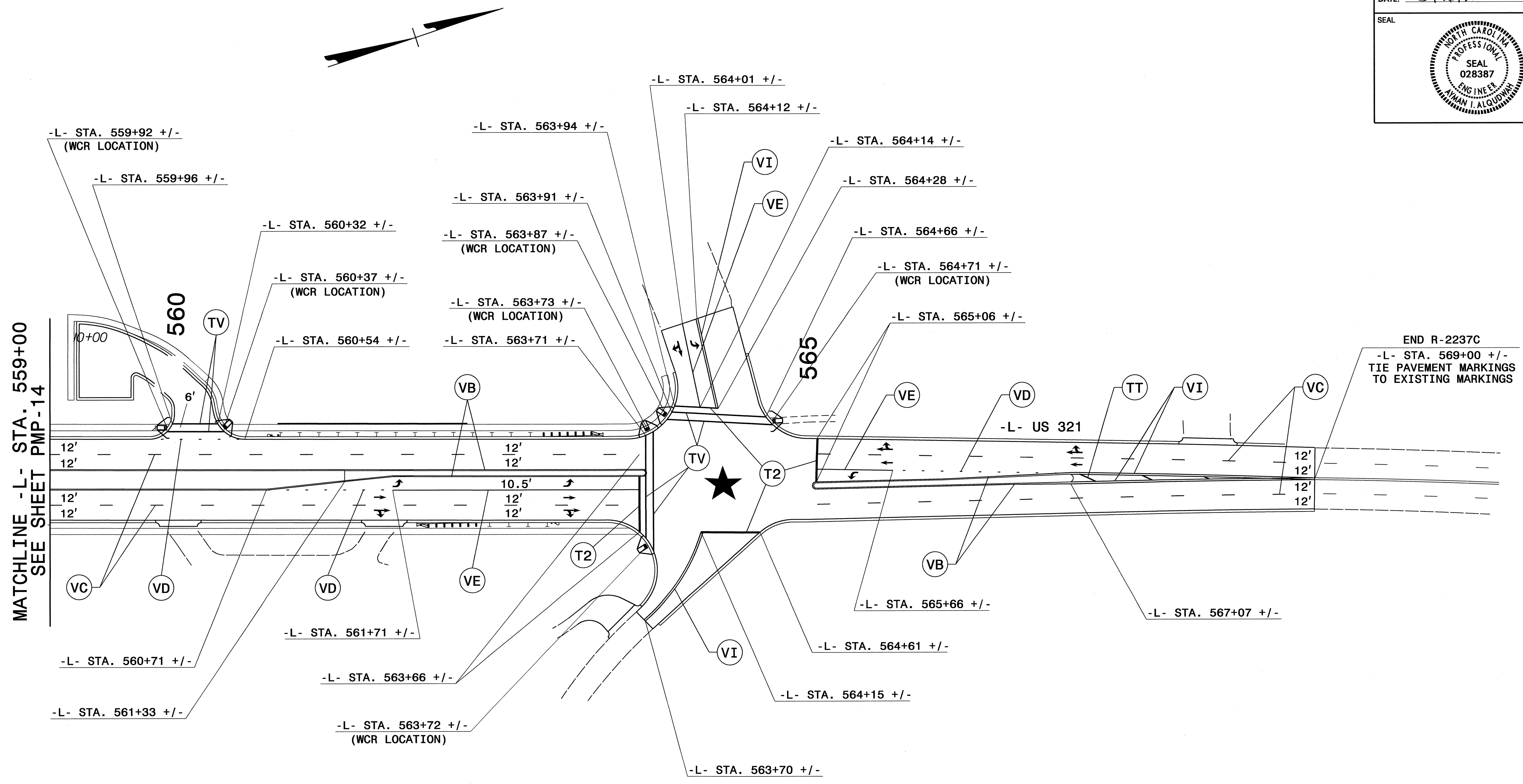

**SYMBOL & PAVEMENT MARKING LEGEND**

	LEFT TURN ARROW		THERMOPLASTIC WHITE STOPBAR (24")
	STRAIGHT ARROW		THERMOPLASTIC YELLOW DIAGONAL (8")
	COMBO STRAIGHT/RIGHT		THERMOPLASTIC WHITE CROSSWALK LINE (8")
			POLYUREA YELLOW EDGELINE (4")
			POLYUREA 10' WHITE SKIP (4")
			POLYUREA 2 FT. 13 FT./SP. WHITE MINISKIP (4")
			POLYUREA WHITE SOLID LANE LINE (4")
			POLYUREA YELLOW DOUBLE CENTER (4")

**PAVEMENT MARKING DETAIL**

I7-MAR-2011 11:51  
 R:\Traffic\Signaling\CADD\PMR-R-2237C.Sgn\_PMP-15.dgn  
 dbeard AT 1E244736