

STATE OF NORTH CAROLINA
DIVISION OF HIGHWAYS

TRANSPORTATION MANAGEMENT PLAN

NASH COUNTY

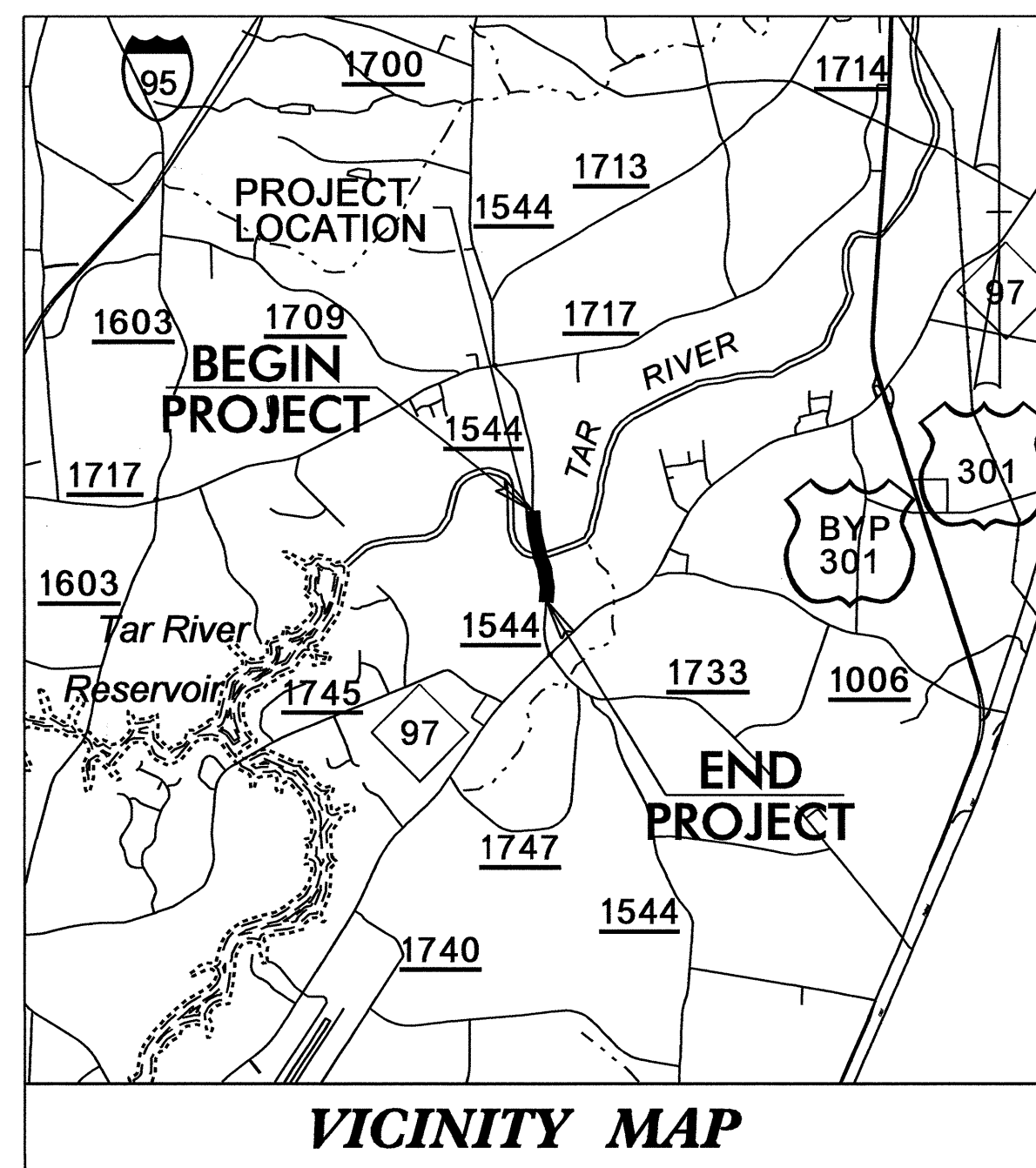
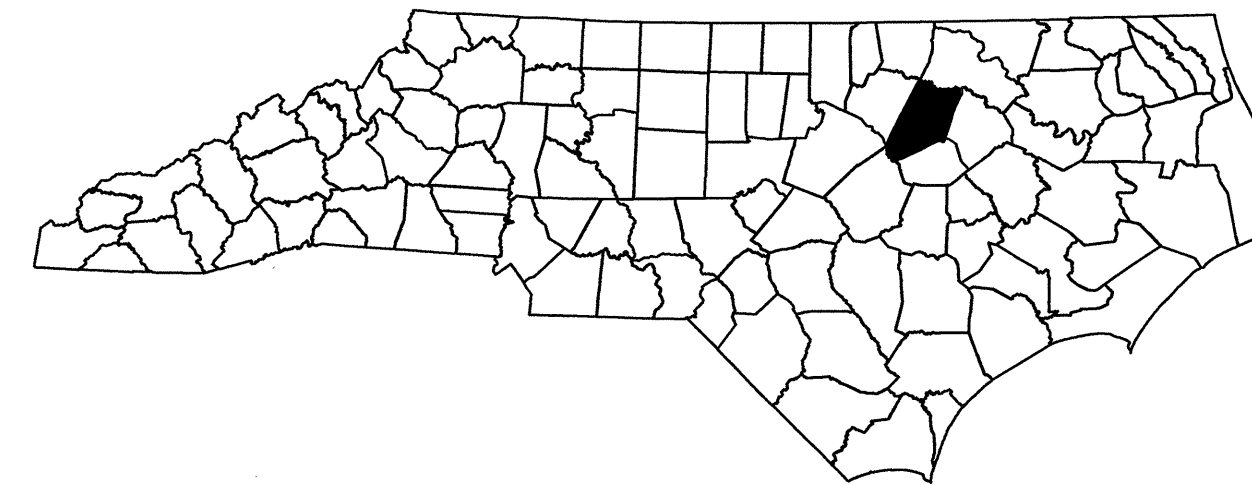

**LOCATION: BRIDGE NO. 56 OVER TAR RIVER ON
SR 1544 (SOUTH HALIFAX RD.)**

**TYPE OF WORK: GRADING, DRAINAGE, PAVING, AND
STRUCTURES**

INDEX OF SHEETS

SHEET NO.	TITLE
TMP-1	TITLE SHEET AND INDEX OF SHEETS
TMP-1A	LIST OF APPLICABLE ROADWAY STANDARD DRAWINGS, LEGEND, AND TEMPORARY PAVEMENT MARKING
TMP-1B	TRANSPORTATION OPERATIONS PLAN: (MANAGEMENT STRATEGIES, GENERAL NOTES, AND LOCAL NOTES)
TMP-2	DETAIL DRAWING FOR TWO-WAY UNDIVIDED WORK ZONE WARNING SIGNS
TMP-3	TEMPORARY TRAFFIC CONTROL PHASE I DETAIL
TMP-4	TEMPORARY TRAFFIC CONTROL PHASE II DETAIL

SHEET NO.
TMP-1

B-421I

TIP PROJECT:

24-JUN-2011 09:56 \\dot\dfs\dot\01\Proj\TIPProjects-B\421I\TrafficControl\TCP\B-421I\TMP-1.dgn smiller AT 248375

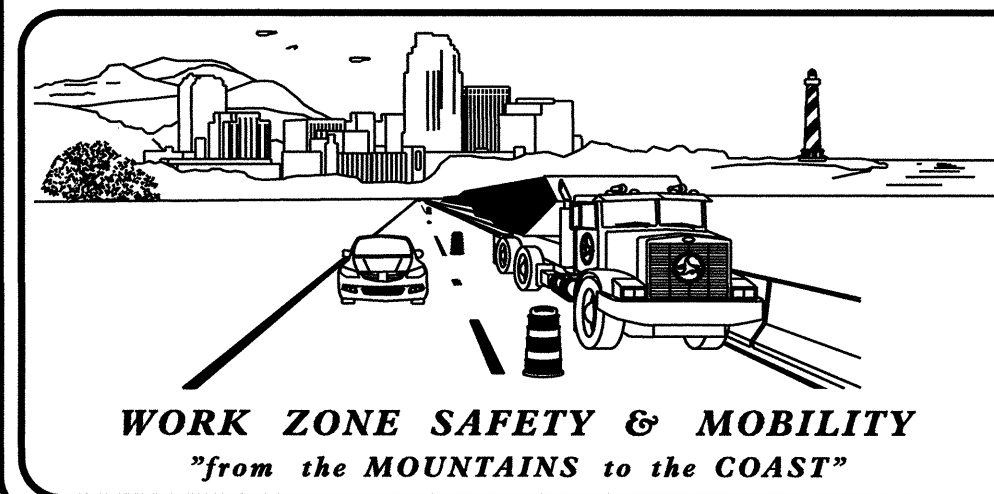

N.C.D.O.T. WORK ZONE TRAFFIC CONTROL
1561 MAIL SERVICE CENTER (MSC) RALEIGH, NC 27699-1561
150 N. GREENFIELD PARKWAY, GARNER, NC 27529 (DELIVERY)
PHONE: (919) 773-2800 FAX: (919) 771-2745

J. S. BOURNE, P.E. STATE TRAFFIC MANAGEMENT ENGINEER
J. S. KITE, P.E. TRAFFIC CONTROL PROJECT ENGINEER
D. W. BISSETTE, P.E. TRAFFIC CONTROL PROJECT DESIGN ENGINEER
S. D. MILLER, P.E. TRAFFIC CONTROL DESIGN ENGINEER

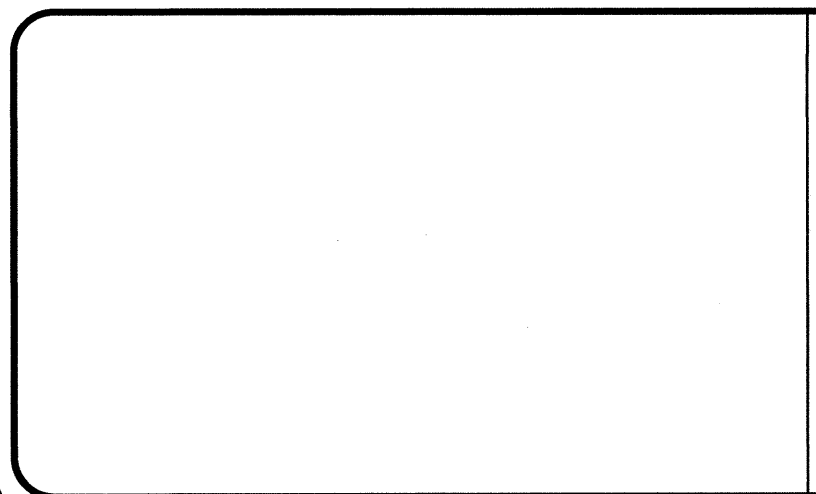
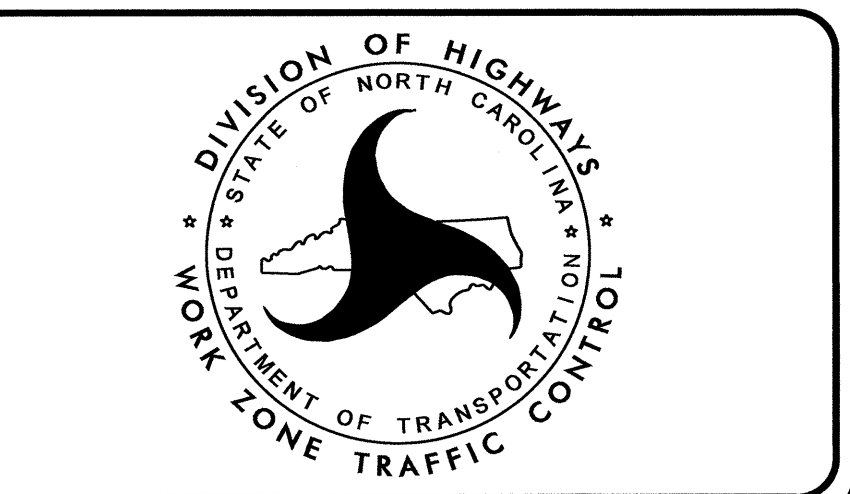

APPROVED: *St. Miller*
DATE: 6-24-11

SEAL







ROADWAY STANDARD DRAWINGS

THE FOLLOWING ROADWAY STANDARDS AS SHOWN IN "ROADWAY STANDARD DRAWINGS" - PROJECT SERVICES UNIT - N.C. DEPARTMENT OF TRANSPORTATION - RALEIGH, N.C., DATED JULY 2006 ARE APPLICABLE TO THIS PROJECT AND BY REFERENCE HEREBY ARE CONSIDERED A PART OF THESE PLANS:

<u>STD. NO.</u>	<u>TITLE</u>
1101.02	TEMPORARY LANE CLOSURES
1101.03	TEMPORARY ROAD CLOSURES
1101.04	TEMPORARY SHOULDER CLOSURES
1101.05	WORK ZONE VEHICLE ACCESSES
1101.11	TRAFFIC CONTROL DESIGN TABLES
1110.01	STATIONARY WORK ZONE SIGNS
1110.02	PORTABLE WORK ZONE SIGNS
1130.01	DRUMS
1135.01	CONES
1145.01	BARRICADES
1150.01	FLAGGING DEVICES
1165.01	TRUCK MOUNTED IMPACT ATTENUATOR
1180.01	SKINNY - DRUM
1205.01	PAVEMENT MARKINGS - LINE TYPES AND OFFSETS
1205.02	PAVEMENT MARKINGS - 2 LANE & MULTILANE ROADWAYS
1205.12	PAVEMENT MARKINGS - BRIDGES
1250.01	PAVEMENT MARKER SPACING
1251.01	RAISED PAVEMENT MARKERS - PERMANENT AND TEMPORARY

LEGEND

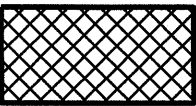
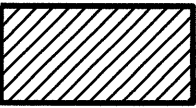









GENERAL

-  DIRECTION OF TRAFFIC FLOW
-  DIRECTION OF PEDESTRIAN TRAFFIC FLOW
- EXIST. PVMT.
-  NORTH ARROW
- PROPOSED PVMT.
-  WORK AREA
-  TEMPORARY PAVING
-  WEDGING
-  USER DEFINED (IF NEEDED)

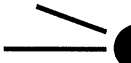

TEMPORARY PAVEMENT MARKING

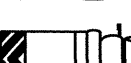
SYMBOL	DESCRIPTION
	PAVEMENT MARKINGS PAINT (4")
PA	WHITE EDGELINE (2X)
PI	YELLOW DOUBLE CENTER (2X)
	MARKERS RAISED PAVEMENT MARKERS
MA	YELLOW/YELLOW



TRAFFIC CONTROL DEVICES

-  BARRICADE (TYPE III)
-  CONE
-  DRUM  SKINNY DRUM  TUBULAR MARKER
-  TEMPORARY CRASH CUSHION
-  FLASHING ARROW PANEL (TYPE C)
-  FLAGGER
-  LAW ENFORCEMENT
-  TRUCK MOUNTED IMPACT ATTENUATOR (TMIA)
-  CHANGEABLE MESSAGE SIGN

TEMPORARY SIGNING

-  PORTABLE SIGN
-  STATIONARY SIGN
-  STATIONARY OR PORTABLE SIGN



SIGNALS

-  EXISTING
-  PROPOSED
-  TEMPORARY

PAVEMENT MARKINGS

- EXISTING LINES
- TEMPORARY LINES



PAVEMENT MARKERS

-  CRYSTAL/CRYSTAL
-  CRYSTAL/RED
-  YELLOW/YELLOW

PAVEMENT MARKING SYMBOLS

-  PAVEMENT MARKING SYMBOLS

24-JUN-2011 10:00 \\dot\dfsroot\01\Proj\TIP\Projects-B\4211\TrafficControl\TCP\B-4211.TMP-1A.dgn scmler AT TE248375

APPROVED: <i>Steve Miller</i>	DATE: 6-24-11		
			<p>ROADWAY STANDARD DRAWINGS, LEGEND, & TEMPORARY PAVEMENT MARKINGS</p>

MANAGEMENT STRATEGIES

- AN ONSITE DETOUR WILL BE CONSTRUCTED TO MAINTAIN TRAFFIC DURING CONSTRUCTION
- PAVEMENT WEDGING WILL BE CONSTRUCTED IN ORDER TO TIE THE EXISTING ROAD INTO THE ONSITE DETOUR
- LOCAL TRAFFIC WITHIN THE ROAD CLOSURE WILL BE MAINTAINED

GENERAL NOTES

CHANGES MAY BE REQUIRED WHEN PHYSICAL DIMENSIONS IN THE DETAIL DRAWINGS, STANDARD DETAILS, AND ROADWAY DETAILS ARE NOT ATTAINABLE TO MEET FIELD CONDITIONS OR RESULT IN DUPLICATE OR UNDESIRED OVERLAPPING OF DEVICES. MODIFICATION MAY INCLUDE: MOVING, SUPPLEMENTING, COVERING, OR REMOVAL OF DEVICES AS DIRECTED BY THE ENGINEER.

THE FOLLOWING GENERAL NOTES APPLY AT ALL TIMES FOR THE DURATION OF THE CONSTRUCTION PROJECT EXCEPT WHEN OTHERWISE NOTED IN THE PLAN OR DIRECTED BY THE ENGINEER.

LANE AND SHOULDER CLOSURE REQUIREMENTS

- A) REMOVE LANE CLOSURE DEVICES FROM THE LANE WHEN WORK IS NOT BEING PERFORMED BEHIND THE LANE CLOSURE OR WHEN A LANE CLOSURE IS NO LONGER NEEDED, OR AS DIRECTED BY THE ENGINEER.
- B) WHEN PERSONNEL AND/OR EQUIPMENT ARE WORKING WITHIN 15 FT OF AN OPEN TRAVEL LANE, CLOSE THE NEAREST OPEN SHOULDER USING ROADWAY STANDARD DRAWING NO. 1101.04 UNLESS THE WORK AREA IS PROTECTED BY BARRIER OR GUARDRAIL OR A LANE CLOSURE IS INSTALLED.
- C) WHEN PERSONNEL AND/OR EQUIPMENT ARE WORKING ON THE SHOULDER ADJACENT TO AN UNDIVIDED FACILITY AND WITHIN 5 FT OF AN OPEN TRAVEL LANE, CLOSE THE NEAREST OPEN TRAVEL LANE USING ROADWAY STANDARD DRAWING NO. 1101.02 UNLESS THE WORK AREA IS PROTECTED BY BARRIER OR GUARDRAIL.
- D) WHEN PERSONNEL AND/OR EQUIPMENT ARE WORKING WITHIN A LANE OF TRAVEL OF AN UNDIVIDED OR DIVIDED FACILITY, CLOSE THE LANE ACCORDING TO THE TRAFFIC CONTROL PLANS, ROADWAY STANDARD DRAWINGS OR AS DIRECTED BY THE ENGINEER. CONDUCT THE WORK SO THAT ALL PERSONNEL AND/OR EQUIPMENT REMAIN WITHIN THE CLOSED TRAVEL LANE.
- E) DO NOT WORK SIMULTANEOUSLY WITHIN 15 FT ON BOTH SIDES OF AN OPEN TRAVELWAY WITHIN THE SAME LOCATION UNLESS PROTECTED WITH GUARDRAIL OR BARRIER.

PAVEMENT EDGE DROP OFF REQUIREMENTS

- F) BACKFILL AT A 6:1 SLOPE UP TO THE EDGE AND ELEVATION OF EXISTING PAVEMENT IN AREAS ADJACENT TO AN OPENED TRAVEL LANE THAT HAS AN EDGE OF PAVEMENT DROP-OFF AS FOLLOWS:

BACKFILL DROP-OFFS THAT EXCEED 2 INCHES ON ROADWAYS WITH POSTED SPEED LIMITS OF 45 MPH OR GREATER.

BACKFILL WITH SUITABLE COMPACTED MATERIAL, AS APPROVED BY THE ENGINEER, AT NO EXPENSE TO THE DEPARTMENT.
- G) DO NOT EXCEED A DIFFERENCE OF 2 INCHES IN ELEVATION BETWEEN OPEN LANES OF TRAFFIC FOR NOMINAL LIFTS OF 1.5 INCHES. INSTALL ADVANCE WARNING "UNEVEN LANES" SIGNS (W8-11) 100 FT IN ADVANCE OF THE UNEVEN AREA.

TRAFFIC PATTERN ALTERATIONS

- H) NOTIFY THE ENGINEER TWENTY ONE (21) CALENDAR DAYS PRIOR TO ANY TRAFFIC PATTERN ALTERATION.

SIGNING

- I) PROVIDE PERMANENT SIGNING.
- J) PROVIDE SIGNING AND DEVICES REQUIRED FOR THE ONSITE DETOUR ACCORDING TO THE ROADWAY STANDARD DRAWINGS AND TRAFFIC CONTROL PLANS.
- K) COVER OR REMOVE ALL SIGNS AND DEVICES REQUIRED FOR THE ONSITE DETOUR WHEN THE ONSITE DETOUR IS NOT IN OPERATION.
- L) ENSURE ALL NECESSARY SIGNING IS IN PLACE PRIOR TO ALTERING ANY TRAFFIC PATTERN.
- M) INSTALL BLACK ON ORANGE "DIP" SIGNS (W8-2) AND/OR "BUMP" SIGNS (W8-1) 100 FT IN ADVANCE OF THE UNEVEN AREA, OR AS DIRECTED BY THE ENGINEER.

TRAFFIC CONTROL DEVICES

- N) SPACE CHANNELIZING DEVICES IN WORK AREAS NO GREATER IN FEET THAN TWICE THE POSTED SPEED LIMIT (MPH), EXCEPT 10 FT ON-CENTER IN RADII, AND 3 FT OFF THE EDGE OF AN OPEN TRAVELWAY, WHEN LANE CLOSURES ARE NOT IN EFFECT. WHEN SKINNY DRUMS ARE ALLOWED, REFER TO SECTION 1180 OF STANDARD SPECIFICATIONS FOR ROADS AND STRUCTURES OR AS SHOWN IN THE PLANS.
- O) PLACE TYPE III BARRICADES, WITH "ROAD CLOSED" SIGN R11-2 ATTACHED, OF SUFFICIENT LENGTH TO CLOSE ENTIRE ROADWAY.

PAVEMENT MARKINGS AND MARKERS

- P) INSTALL PAVEMENT MARKINGS AND PAVEMENT MARKERS ON THE FINAL SURFACE AS SHOWN IN THE PAVEMENT MARKING PLAN.
- Q) INSTALL TEMPORARY PAVEMENT MARKINGS AND TEMPORARY PAVEMENT MARKERS ON INTERIM LAYERS OF PAVEMENT AS FOLLOWS:

ROAD NAME	MARKING	MARKER
SOUTH HALIFAX RD SR 1544	PAINT	YELLOW/YELLOW
- R) PLACE TWO APPLICATIONS OF PAINT FOR TEMPORARY TRAFFIC PATTERNS. PLACE A SECOND APPLICATION OF PAINT SIX (6) MONTHS AFTER THE INITIAL APPLICATION AND EVERY SIX MONTHS AS DIRECTED BY THE ENGINEER.
- S) TIE PROPOSED PAVEMENT MARKING LINES TO EXISTING PAVEMENT MARKING LINES.
- T) REMOVE/REPLACE ANY CONFLICTING/DAMAGED PAVEMENT MARKINGS AND MARKERS BY THE END OF EACH DAY'S OPERATION.

MISCELLANEOUS

- U) IN THE EVENT A TIE-IN CANNOT BE MADE IN ONE DAYS TIME, BRING THE TIE-IN AREA TO AN APPROPRIATE ROADWAY ELEVATION, AS DETERMINED BY THE ENGINEER. PLACE BLACK ON ORANGE "LOOSE GRAVEL" SIGNS (W8-7) AND BLACK ON ORANGE "PAVEMENT ENDS" SIGNS (W8-3) AND RESPECTIVELY IN ADVANCE OF THE UNEVEN AREAS. USE DRUMS TO DELINEATE THE EDGE OF ROADWAY ALONG UNPAVED AREAS.

24-JUN-2010 09:01 \\dot\c\p\proj\TIP\Projects-B\B4211\TrafficControl\TCP\B-4211-TMP-1B.dgn
sdmiller AT 1E248375

APPROVED: *Steve Miller* DATE: 6-29-11

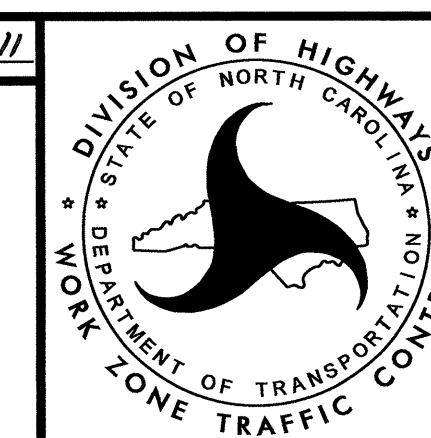
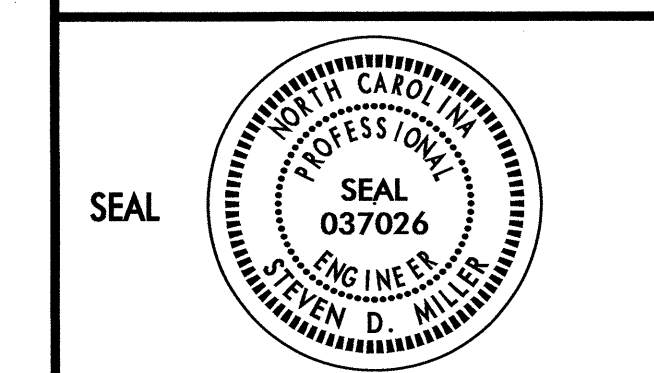

**TRANSPORTATION
OPERATIONS
PLAN**

TWO-WAY UNDIVIDED (L-LINES)

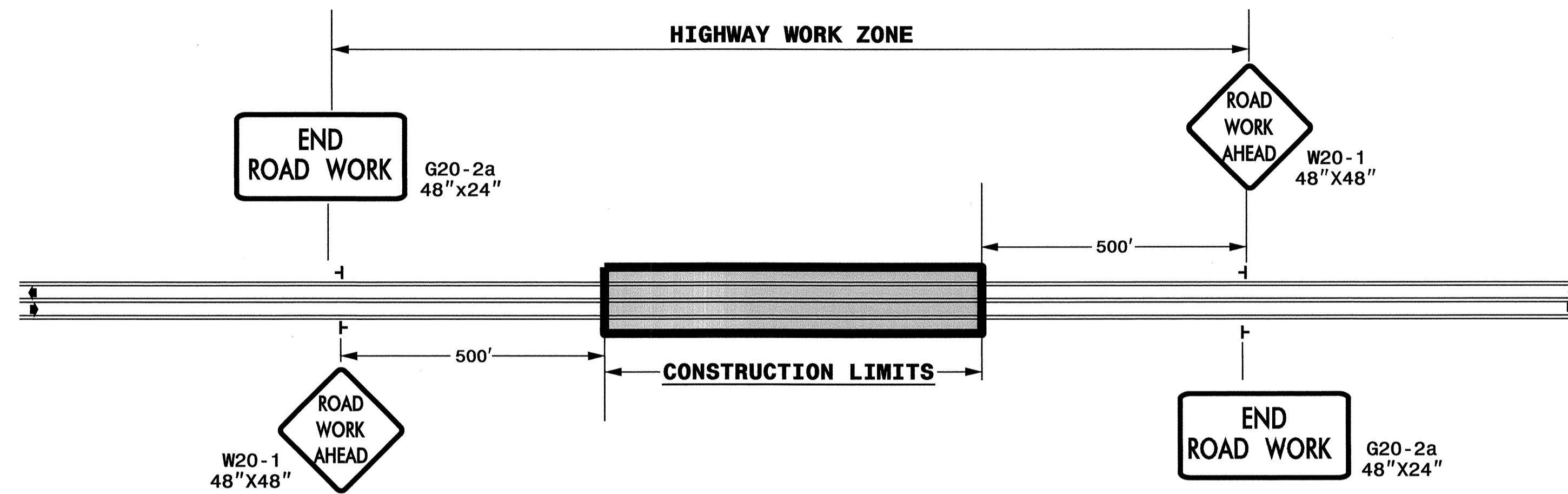

STATE OF NORTH CAROLINA
DEPT. OF TRANSPORTATION
DIVISION OF HIGHWAYS
RALEIGH, N.C.

DETAIL DRAWING FOR
TWO-WAY UNDIVIDED
WORK ZONE WARNING SIGNS

GENERAL NOTES

- USE FLUORESCENT ORANGE SHEETING (TYPE VII OR HIGHER) ON ALL ADVANCED WORK ZONE SIGNS.
- DO NOT INSTALL ADVANCE WARNING SIGNS MORE THAN 3 DAYS PRIOR TO BEGINNING OF WORK.
- SIGNS SHOWN ARE REQUIRED FOR WORK ZONES THAT WILL REMAIN IN EFFECT OVERNIGHT. FOR SHORT-TERM DAILY MAINTENANCE TYPE OPERATIONS, THIS SIGNING APPLICATION IS OPTIONAL; MAY USE ONLY APPLICABLE ROADWAY STANDARD DRAWINGS INSTEAD. HOWEVER, IF THIS SIGNING APPLICATION IS USED, SIGNS MAY BE PORTABLE MOUNTED.
- ALL SIGN SPACING DIMENSIONS ARE APPROXIMATE, FIELD ADJUST AS NECESSARY OR AS DIRECTED.
- USE 3LB STEEL U-CHANNEL POST OR 4" X 4" WOOD POST FOR ALL WORK ZONE SIGNS. 3LB STEEL U-CHANNEL POSTS MUST MEET THE REQUIREMENTS OF STANDARD SPECIFICATION SECTION 1094-1(B), MAY BE GALVANIZED STEEL, OR MAY BE PAINTED GREEN BY THE POST MANUFACTURER. SQUARE STEEL TUBING POSTS HAVING EQUIVALENT STRENGTH OF THE 3 LB STEEL U-CHANNEL POST ARE ALSO ACCEPTABLE FOR USE. ERECT SIGNS PER ROADWAY STANDARD DRAWING 1110.01. PAYMENT FOR WOOD POSTS, 3LB STEEL U-CHANNEL AND SQUARE STEEL TUBING POSTS WITH SIGNS WILL BE MADE ACCORDING TO STANDARD SPECIFICATION "WORK ZONE SIGNS" SECTION 1110.
- WHEN NECESSARY, USE SPLICING IN ACCORDANCE WITH ROADWAY STANDARD DRAWING NO. 1110.01. REMOVE ENTIRE POST WHEN REMOVING SIGNS WITH SPLICED POSTS.
- DO NOT BACK BRACE SIGN SUPPORTS.

LEGEND

- ┆ STATIONARY SIGN
- ◀ DIRECTION OF TRAFFIC FLOW

SHEET 1 OF 1

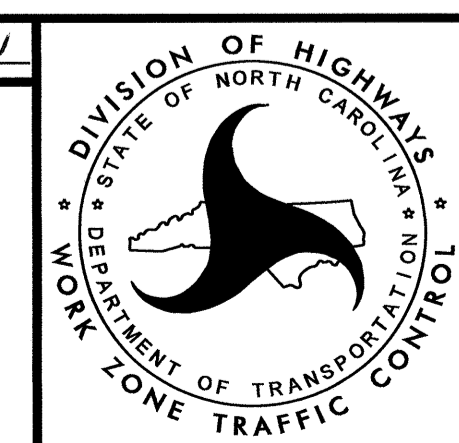
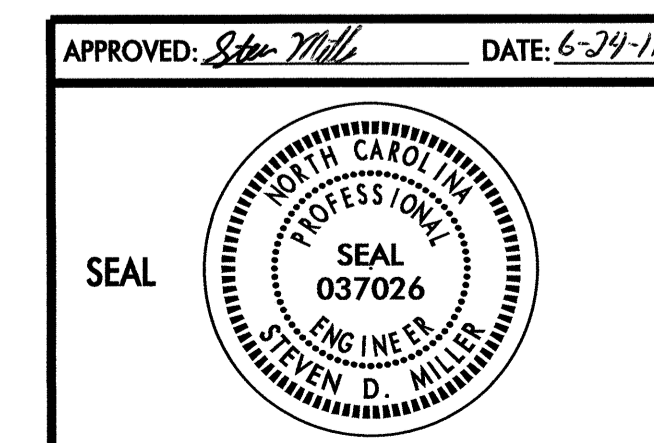

DETAIL DRAWING FOR
TWO-WAY UNDIVIDED
WORK ZONE WARNING SIGNS

24-JUN-2011 10:02 AM
C:\D:\Y\G\AT\OP\Projects\B\B421\TrafficControl\TCP\B-421\TMP-2.dgn
scmiller AT 1E248375

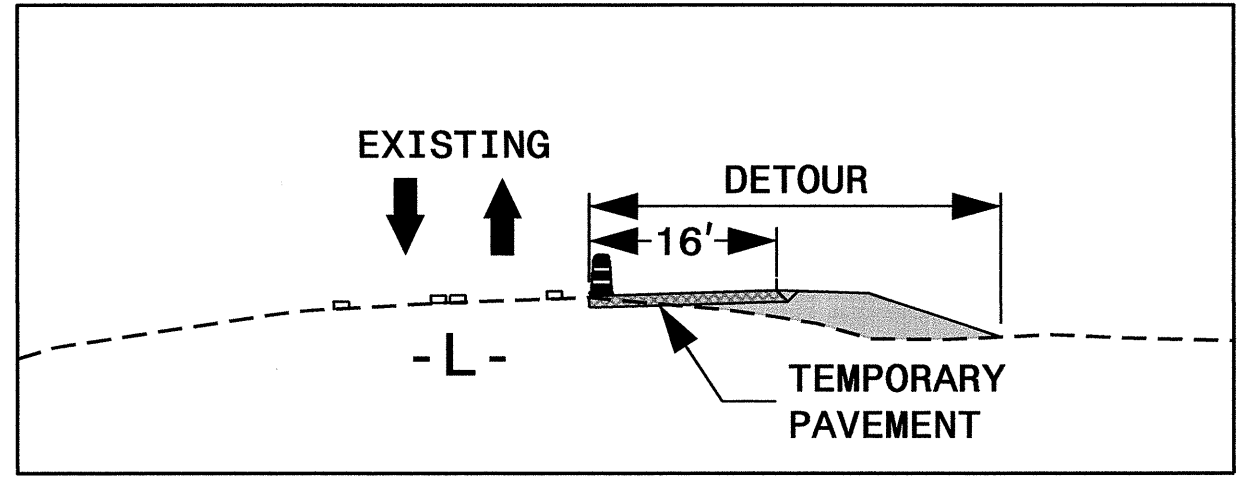
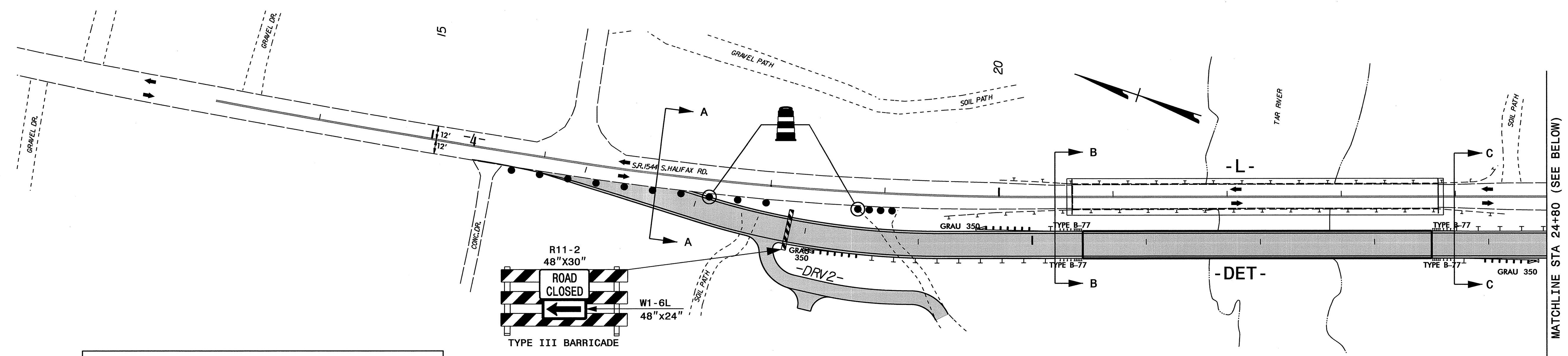

A-A 17+00

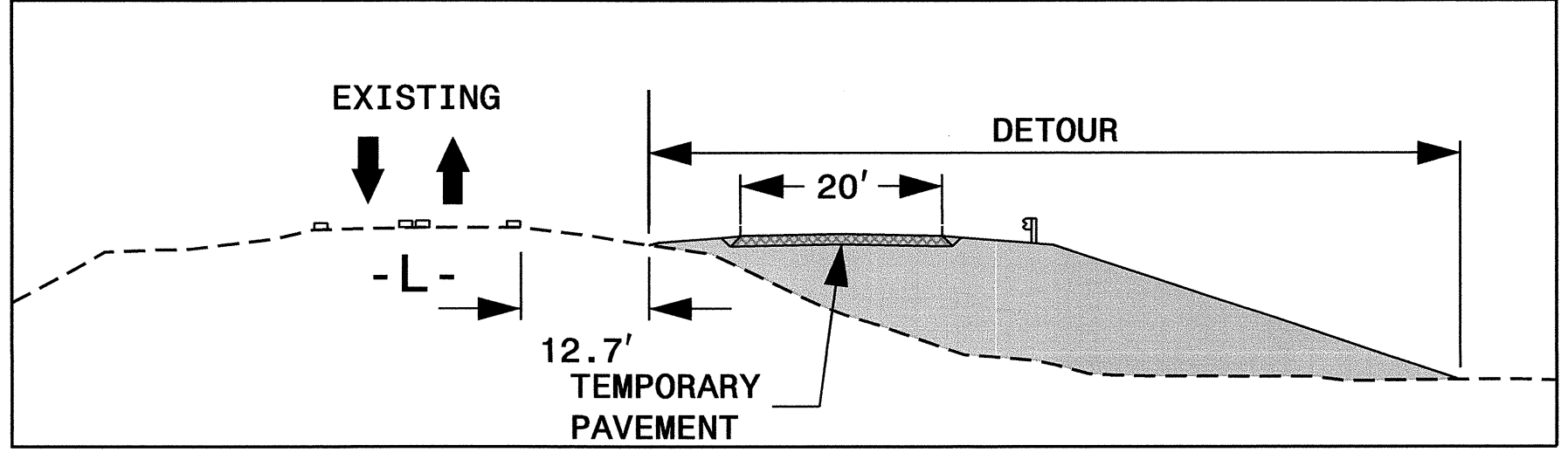

B-B 20+49

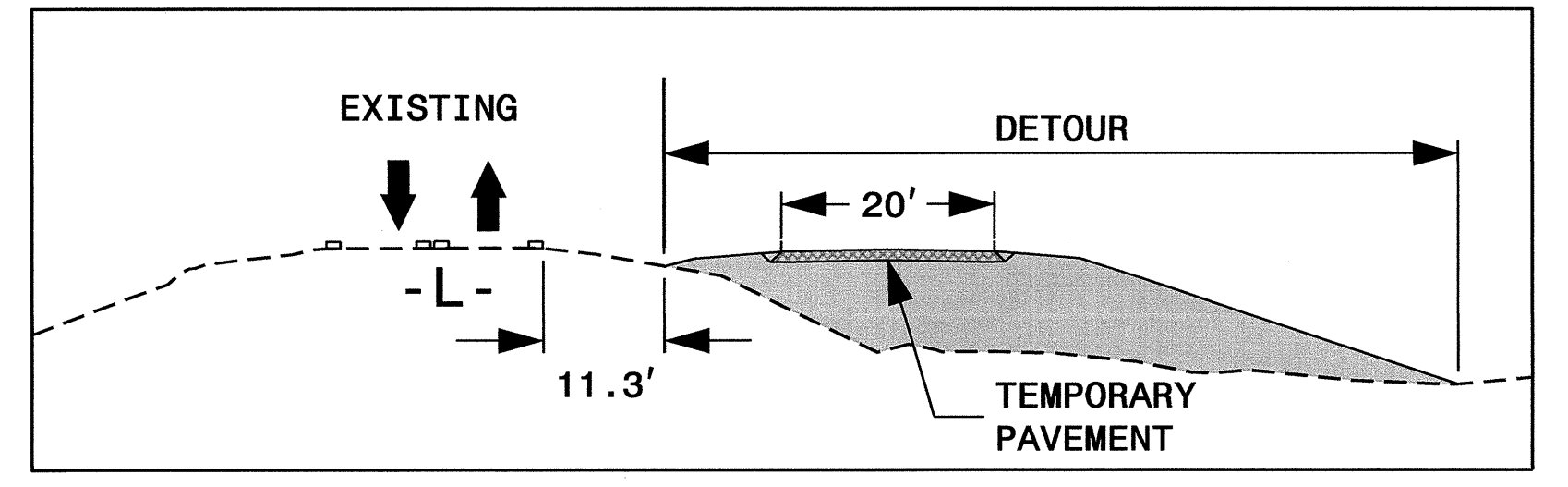

C-C 23+99

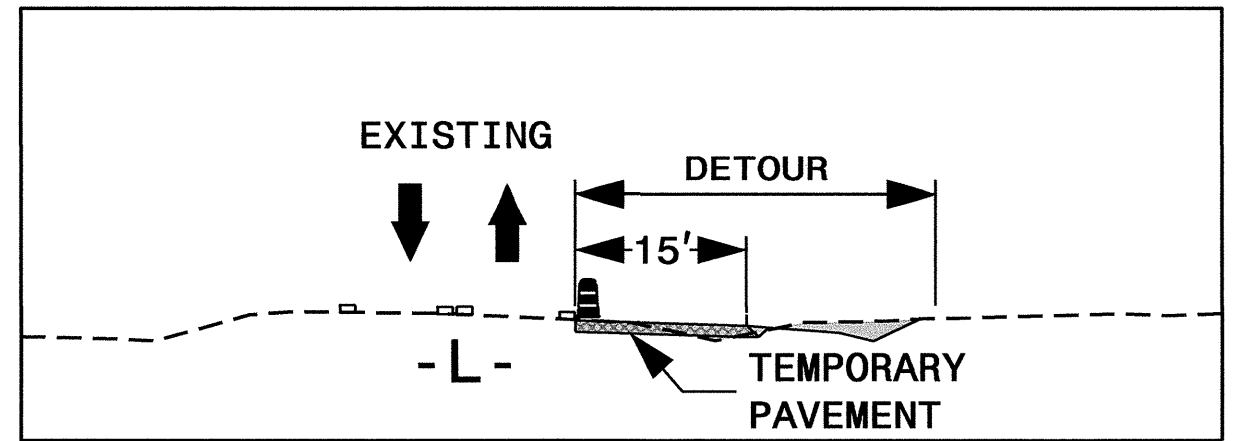
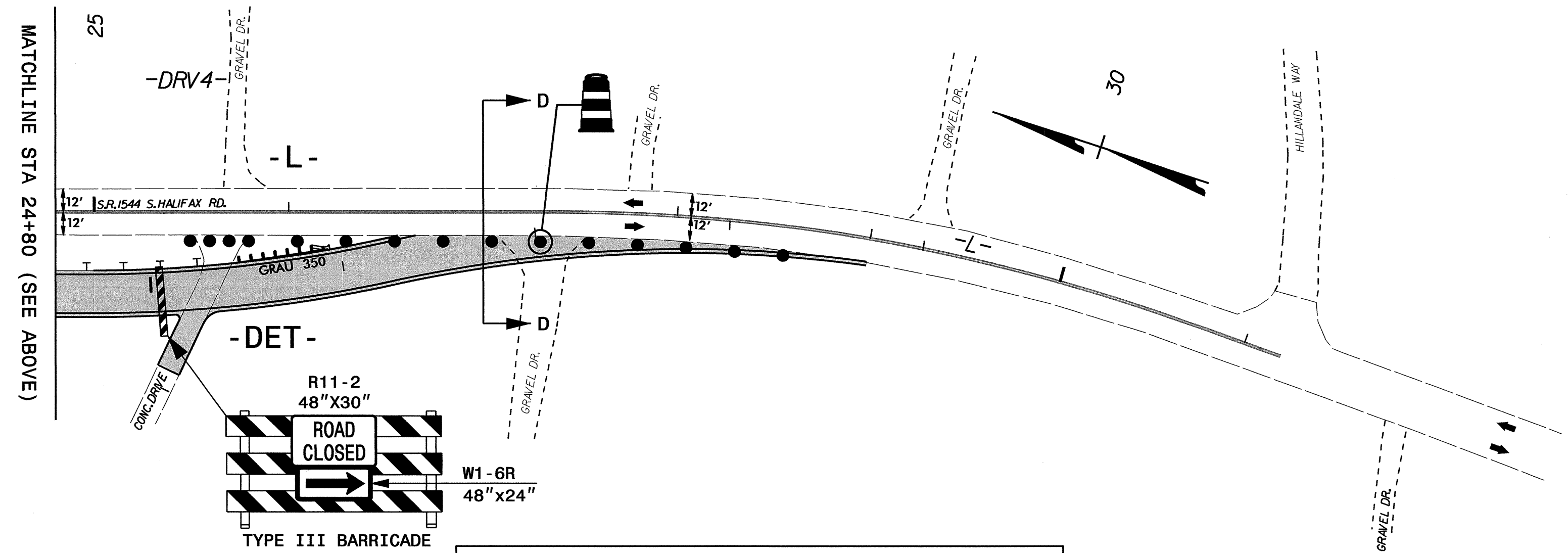

D-D 27+00

PHASE I

TRAFFIC SHALL BE MAINTAINED IN THE EXISTING TWO-LANE, TWO-WAY PATTERN DURING PHASE I. MAINTAIN DRIVEWAY ACCESS.

STEP 1: INSTALL DRUMS, BARRICADES, AND ADVANCE WARNING SIGNS AS SHOWN ON TMP-2 AND TMP-3.

STEP 2: USING ROADWAY STANDARD DRAWING 1101.02 SHEET 1 OF 9 AND FLAGGERS AS NEEDED:
 -CONSTRUCT THE -DET- STRUCTURE, -DET- ROADWAY, AND DRIVEWAY ACCESSES AS SHOWN ON TMP-3.

USING ROADWAY STANDARD DRAWING 1101.02 SHEET 1 OF 9 AND FLAGGERS AS NEEDED COMPLETE STEP 3 IN A CONTINUOUS MANNER:

- STEP 3:
- TIE THE DETOUR INTO THE EXISTING ROADWAY
 - REMOVE THE BARRICADES AND DRUMS ON -DET-
 - PLACE TEMPORARY PAVEMENT MARKINGS AND MARKERS ON -DET- AS SHOWN ON TMP-4 AND IN ACCORDANCE WITH THE TEMPORARY PAVEMENT MARKING SCHEDULE ON TMP-1A, REMOVING ANY CONFLICTING EXISTING PAVEMENT MARKINGS.
 - INSTALL THE TWO W24-1 SIGNS SHOWN ON TMP-4.
 - SHIFT TRAFFIC TO A TWO-LANE, TWO-WAY PATTERN ON -DET-.
 - PLACE DRUMS AND BARRICADES CLOSING -L- AS SHOWN ON TMP-4.

APPROVED: *Stu Mills* DATE: 6-24-11

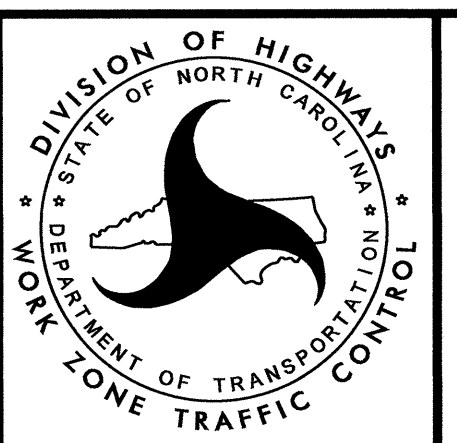
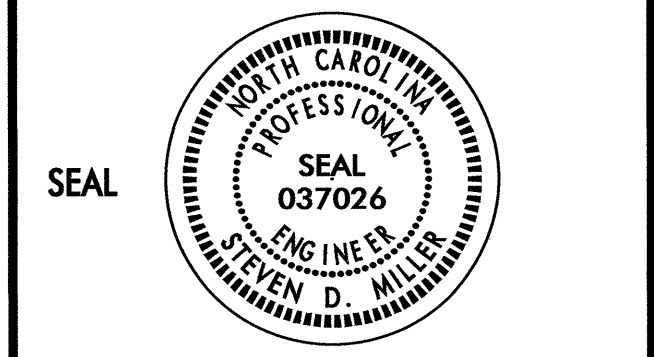

PHASE I DETAIL

24-JUN-2011 10:03 \\dot\dfs\proj\TIP\Projects-B\4211\TrafficControl\TCP\B-4211-TMP-3.dgn somiler AT 1248375

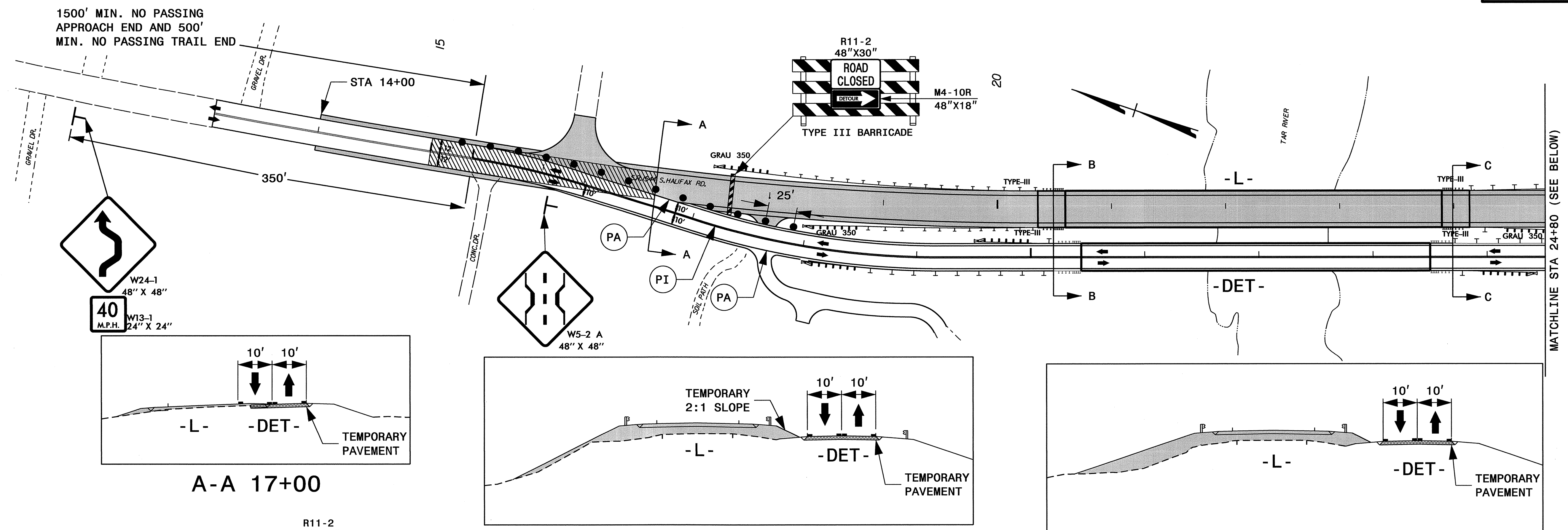

1500' MIN. NO PASSING APPROACH END AND 500' MIN. NO PASSING TRAIL END

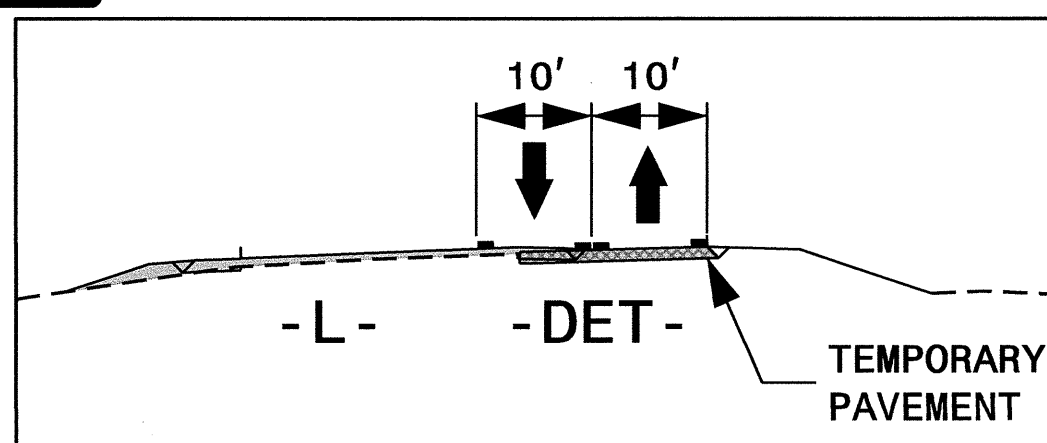
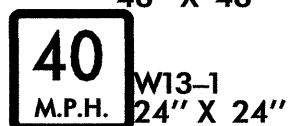
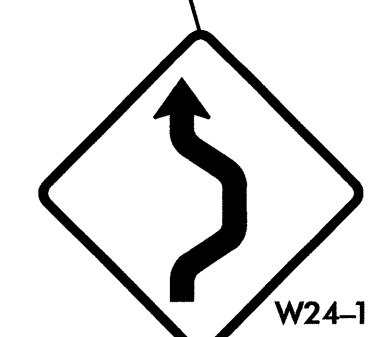

A-A 17+00

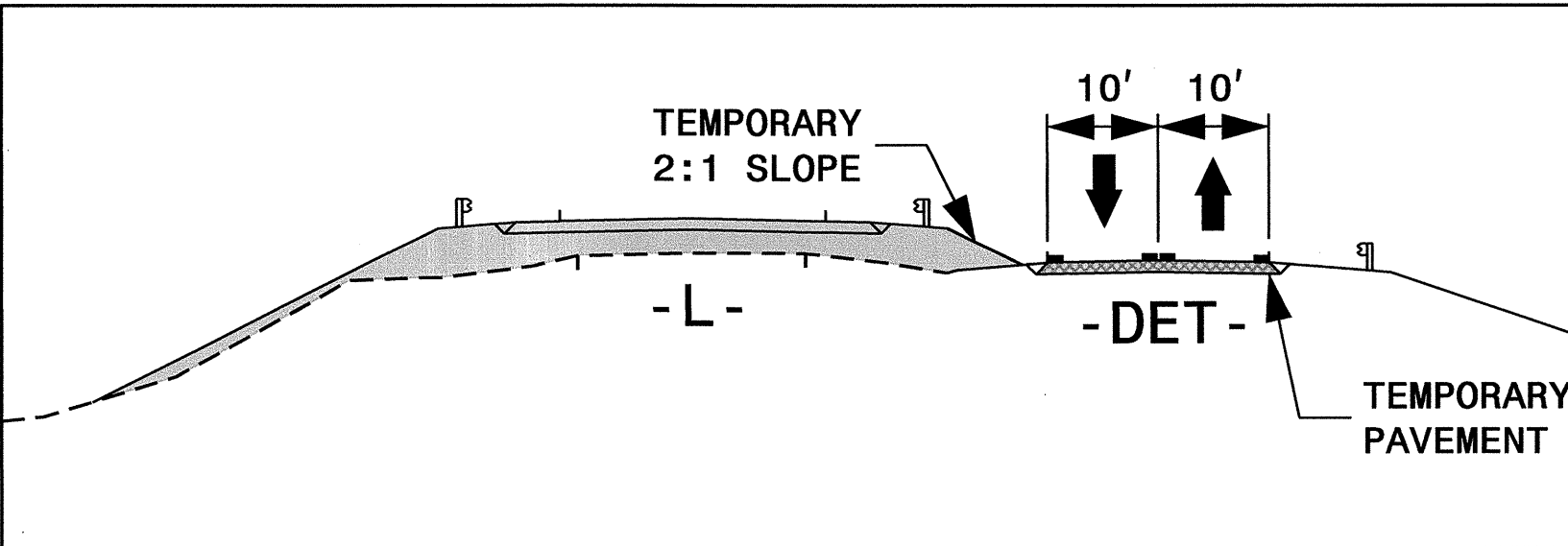

B-B 20+49

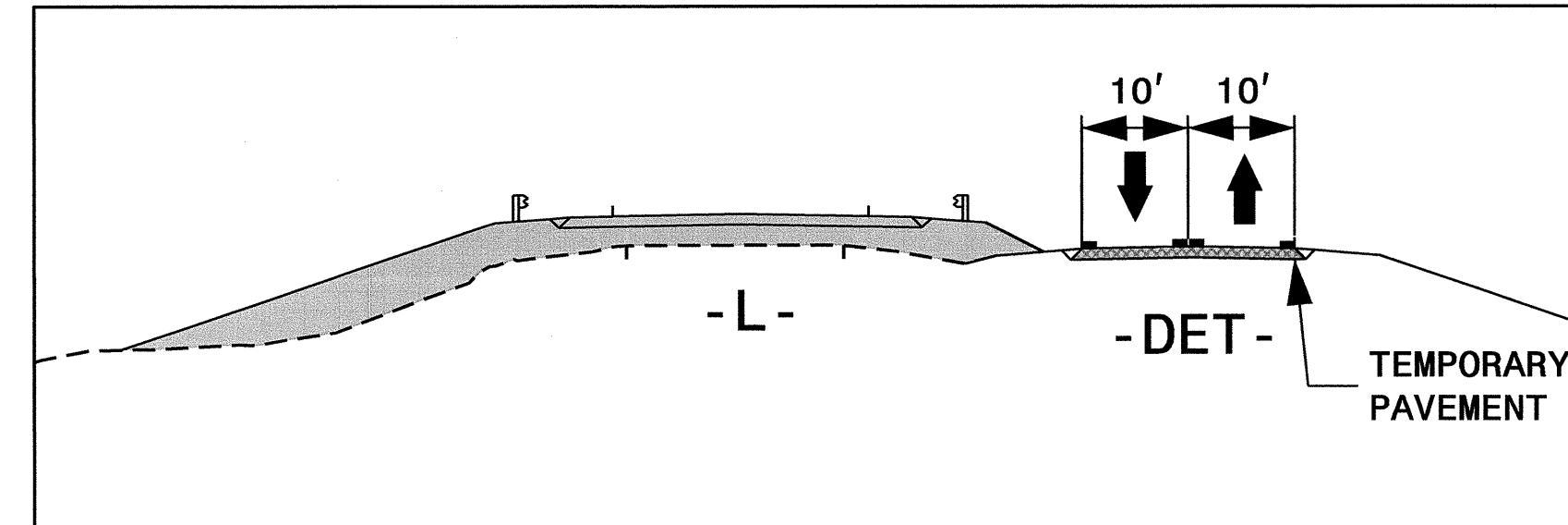

C-C 23+99

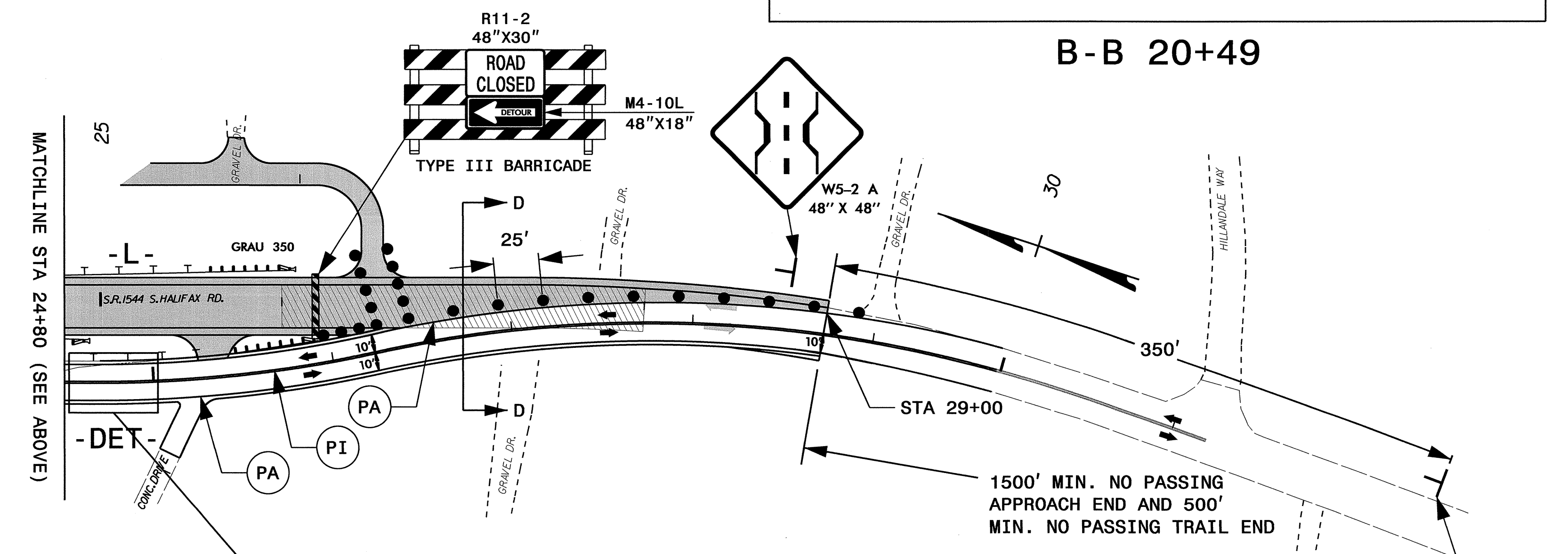

MATCHLINE STA 24+80 (SEE ABOVE)

1500' MIN. NO PASSING APPROACH END AND 500' MIN. NO PASSING TRAIL END

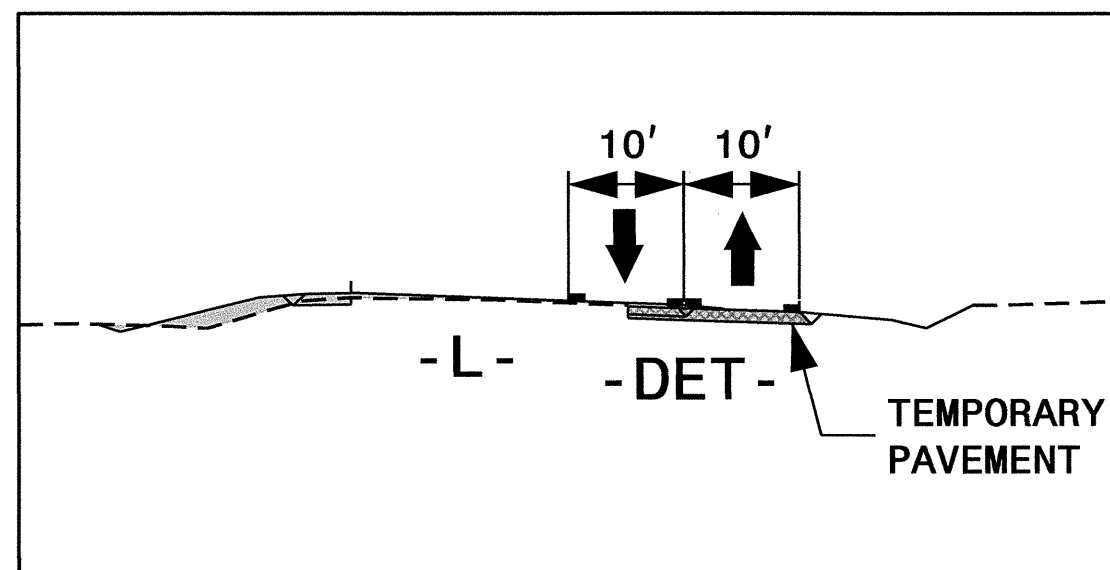

D-D 27+00

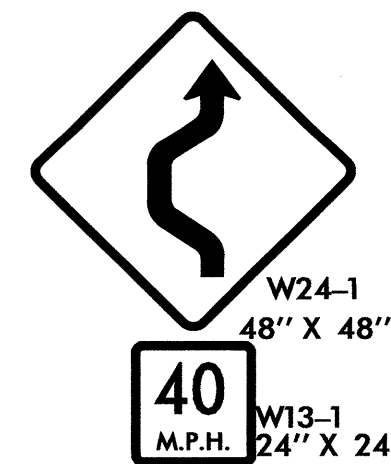

PAVEMENT MARKERS AND MARKINGS FOR TEMPORARY DETOUR	
YELLOW/YELLOW RAISED PAVEMENT MARKERS ON 20 FT. SPACING	WHITE EDGE LINE
CRYSTAL/CRYSTAL RAISED PAVEMENT MARKERS ALONG EDGE LINE ON 20 FT. SPACING	DOUBLE YELLOW CENTER LINE
	WHITE EDGE LINE
300' MINIMUM BOTH SIDES OF BRIDGE	

PHASE II

TRAFFIC SHALL BE MAINTAINED IN A TEMPORARY TWO-LANE, TWO-WAY PATTERN RIGHT OF -L- DURING PHASE II. MAINTAIN DRIVEWAY ACCESS.

- STEP 1: USING ROADWAY STANDARD DRAWING 1101.02 SHEET 1 OF 9 AND FLAGGERS AS NEEDED COMPLETE THE FOLLOWING:
- REMOVE THE EXISTING -L- STRUCTURE
 - CONSTRUCT THE PROPOSED -L- STRUCTURE AND -L- ROADWAY UP TO BUT NOT INCLUDING THE FINAL SURFACE LAYER FROM STA 14+00 TO STA 29+00 AS SHOWN ON TMP-4. USE WEDGING AS NECESSARY TO MAINTAIN TRAFFIC ON -DET- ACROSS -L- CONSTRUCTION.

USING ROADWAY STANDARD DRAWING 1101.02 SHEET 1 OF 9 AND FLAGGERS AS NEEDED COMPLETE STEP 2 IN A CONTINUOUS MANNER:

- STEP 2: -WEDGE A TIE IN FROM -DET- TO -L-
 -PLACE TEMPORARY PAVEMENT MARKINGS AND MARKERS ON -L-
 -REMOVE THE BARRICADES AND DRUMS ON -L-
 -COVER OR REMOVE THE TWO W24-1 SIGNS
 -SHIFT TRAFFIC TO A TWO-LANE, TWO-WAY PATTERN ON -L-
 -PLACE DRUMS AND BARRICADES CLOSING -DET- AS PREVIOUSLY PLACED IN PHASE I.

PHASE III

- STEP 1: USING ROADWAY STANDARD DRAWING 1101.02 SHEET 1 OF 9 AND FLAGGERS AS NEEDED:
 -REMOVE THE -DET- STRUCTURE AND ROADWAY.
 -PLACE THE FINAL SURFACE LAYER ON -L- FROM STA 14+00 TO STA 29+00 AND PLACE FINAL PAVEMENT MARKINGS.

STEP 2: REMOVE ALL ADVANCE WARNING SIGNS AND TRAFFIC CONTROL DEVICES.

APPROVED: *St. Mills* DATE: 6-24-11

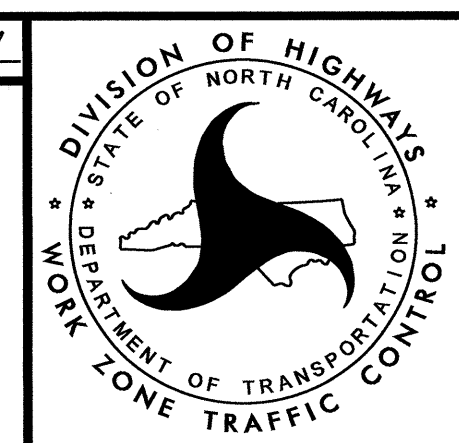
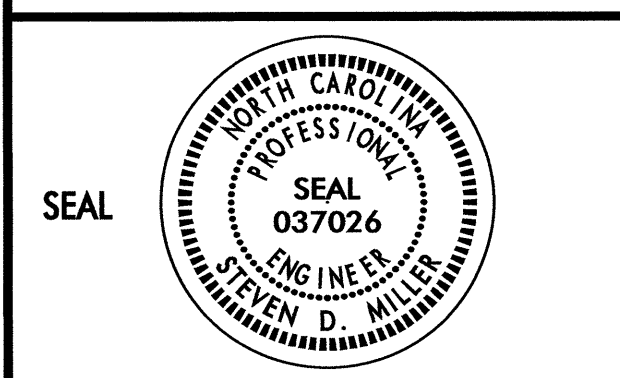

PHASE II DETAIL

24-JUN-2011 10:04 \\dot\dfsroot\01\Proj\TIP\Projects-B\4211\TrafficControl\TCP\B-4211-TMP-4.dgn scmillert AT TE248375