

**STATE OF NORTH CAROLINA
DEPARTMENT OF TRANSPORTATION**

**PAVEMENT MARKING PLAN
BURKE COUNTY**

**LOCATION: MORGANTON - NC 18 (STERLING STREET)
AND I-40 INTERCHANGE**

TIP NO. U-2550B	SHEET NO. PMP-1
APPROVED: <i>Ayman Alqudwah</i>	
DATE: 3-7-11	
SEAL	
	

T.I.P.: U-2550B
CONTRACT: C202622

ROADWAY STANDARD DRAWING

THE FOLLOWING ROADWAY STANDARDS AS APPEAR IN "ROADWAY STANDARD DRAWINGS" - PROJECT SERVICES UNIT - N.C. DEPARTMENT OF TRANSPORTATION - RALEIGH, N.C., DATED JULY 2006 ARE APPLICABLE TO THIS PROJECT AND BY REFERENCE HEREBY ARE CONSIDERED A PART OF THESE PLANS:

STD. NO.	TITLE
1205.01	PAVEMENT MARKINGS - LINE TYPES AND OFFSETS
1205.02	PAVEMENT MARKINGS - 2 LANE AND MULTILANE ROADWAYS
1205.03	PAVEMENT MARKINGS - INTERCHANGES
1205.04	PAVEMENT MARKINGS - INTERSECTIONS
1205.05	PAVEMENT MARKINGS - TURN LANES
1205.06	PAVEMENT MARKINGS - THRU LANE DROPS
1205.07	PAVEMENT MARKINGS - PEDESTRIAN CROSSINGS
1205.08	PAVEMENT MARKINGS - SYMBOL AND WORD MESSAGES
1205.09	PAVEMENT MARKINGS - PAINTED ISLANDS
1205.12	PAVEMENT MARKINGS - BRIDGES
1250.01	PAVEMENT MARKER SPACING
1251.01	RAISED PAVEMENT MARKERS - TEMPORARY AND PERMANENT
1253.01	SNOWPLOWABLE RAISED PAVEMENT MARKERS
1261.01	GUARDRAIL AND BARRIER DELINEATOR SPACING
1261.02	GUARDRAIL AND BARRIER DELINEATOR TYPES
1262.01	GUARDRAIL END DELINEATION

GENERAL NOTES

THE FOLLOWING GENERAL NOTES APPLY AT ALL TIMES FOR THE DURATION OF THE CONSTRUCTION PROJECT, EXCEPT WHEN OTHERWISE NOTED IN THE PLAN, OR DIRECTED BY THE ENGINEER.

- A) INSTALL PAVEMENT MARKINGS AND PAVEMENT MARKERS ON THE FINAL SURFACE AS FOLLOWS:

ROAD NAME	MARKING	MARKER
NC 18 & -Y- LINES	THERMOPLASTIC	SNOWPLOWABLE MARKERS
I-40 PLUS RAMPS & LOOPS	THERMOPLASTIC	SNOWPLOWABLE MARKERS
BRIDGES	COLD APPLIED PLASTIC (III)	PERMANENT RAISED
- D) TIE PROPOSED PAVEMENT MARKING LINES TO EXISTING PAVEMENT MARKING LINES.
- E) REMOVE/REPLACE ANY CONFLICTING/DAMAGED PAVEMENT MARKINGS AND MARKERS.
- F) PASSING ZONES WILL BE DETERMINED IN THE FIELD AND MUST BE APPROVED BY THE ENGINEER.
- G) STOPBAR LOCATION AT NON-SIGNALIZED INTERSECTIONS MAY BE ADJUSTED AS DIRECTED BY THE ENGINEER.
- H) REMOVE ALL RESIDUE AND SURFACE LAITANCE BY ACCEPTABLE METHODS ON THE BRIDGE DECKS PRIOR TO PLACING COLD APPLIED PLASTIC (TYPE III) PAVEMENT MARKING.

INDEX

SHEET NO.	DESCRIPTION
PMP-1	PAVEMENT MARKING PLAN TITLE SHEET
PMP-2	PAVEMENT MARKING SCHEDULE
PMP-3-11	PAVEMENT MARKING DETAIL

PLAN PREPARED BY: N.C.D.O.T. SIGNING AND DELINEATION UNIT

AYMAN I. ALQUDWAH, PE SIGNING & DELINEATION REGIONAL ENGINEER

DERRICK H. BEARD SIGNING & DELINEATION PROJECT DESIGN ENGINEER

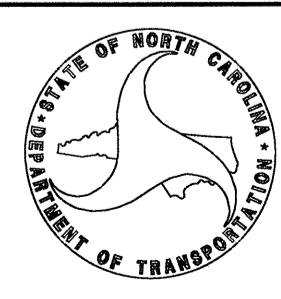

TIP NO.	SHEET NO.
U-2550B	PMP-2
APPROVED: <i>[Signature]</i>	
DATE: 3-7-11	
SEAL	



U-2550B PAVEMENT MARKING SCHEDULE

SYMBOL	DESCRIPTION
	FINAL PAVEMENT MARKINGS
	THERMOPLASTIC (12", 90 MILS)
TY	WHITE GORELINE
	THERMOPLASTIC (24", 120 MILS)
T2	WHITE STOPBAR
	THERMOPLASTIC (4", 120 MILS)
T11	2 FT. - 8 FT./SP YELLOW MINISKIP
T8	2 FT. - 8 FT./SP WHITE MINISKIP
TC	10 FT. WHITE SKIP
TD	2 FT. - 13 FT./SP WHITE MINISKIP
TE	WHITE SOLID LANE LINE
TI	YELLOW DOUBLE CENTER
	THERMOPLASTIC (4", 90 MILS)
TA	WHITE EDGE LINE
TB	YELLOW EDGE LINE
	COLD APPLIED PLASTIC (6") Type3 - Permanent Wet Reflective
C6	WHITE EDGE LINE
C7	YELLOW EDGE LINE
CK	10 FT. WHITE SKIP
CL	2 FT. - 13 FT./SP WHITE MINISKIP
	THERMOPLASTIC (6", 120 MILS)
TJ	10 FT. WHITE SKIP
TK	2 FT. - 13 FT./SP WHITE MINISKIP
TL	WHITE SOLID LANE LINE
	THERMOPLASTIC (6", 90 MILS)
T6	WHITE EDGE LINE
T7	YELLOW EDGE LINE
	THERMOPLASTIC (8", 120 MILS)
TV	WHITE CROSSWALK LINE
	THERMOPLASTIC (8", 90 MILS)
TP	WHITE GORELINE
TQ	WHITE DIAGONAL
TT	YELLOW DIAGONAL
	THERMOPLASTIC PAVEMENT MARKING SYMBOLS (90 MILS)
UA	LEFT TURN ARROW
UB	RIGHT TURN ARROW
UC	STRAIGHT ARROW
UE	COMBO STRAIGHT/RIGHT
UN	24" YIELD LINE ARROW
	MARKERS
	PERMANENT RAISED PAVEMENT MARKERS
MB	CRYSTAL & RED
	SNOWPLOWABLE RAISED PAVEMENT MARKERS
ME	YELLOW & YELLOW
MF	CRYSTAL & RED

PAVEMENT MARKING SCHEDULE

04-MAR-2011 10:22
R:\Tratfic\Signing\CADD\PMU-U-2550B.Sgn_PMP-TITLESHEETS.dgn
dhbeard AT TE244736

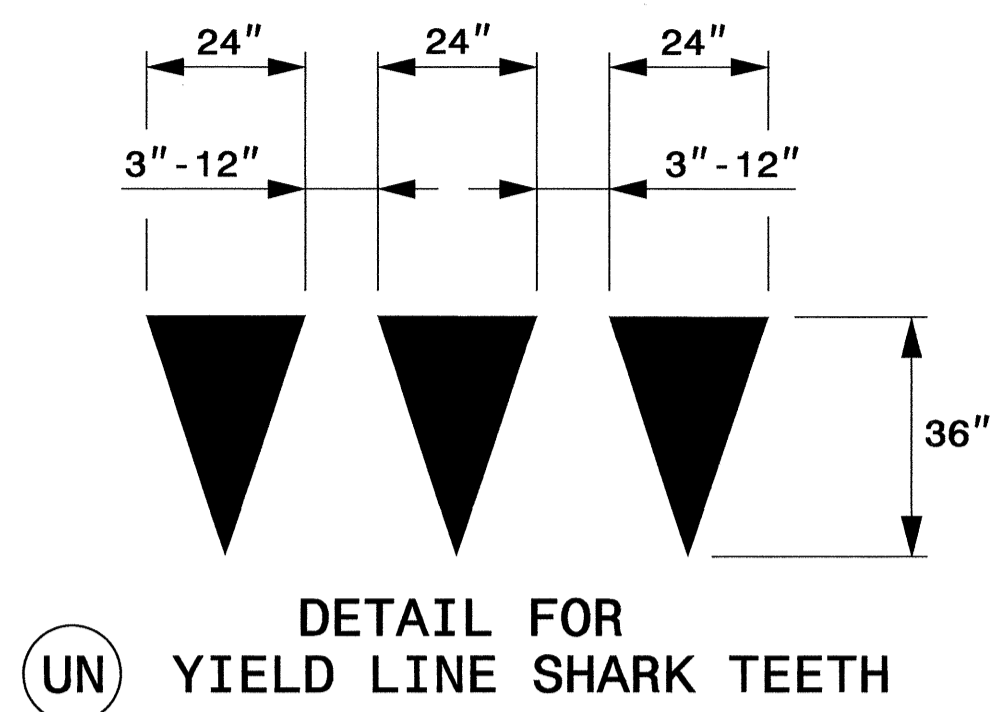

UN

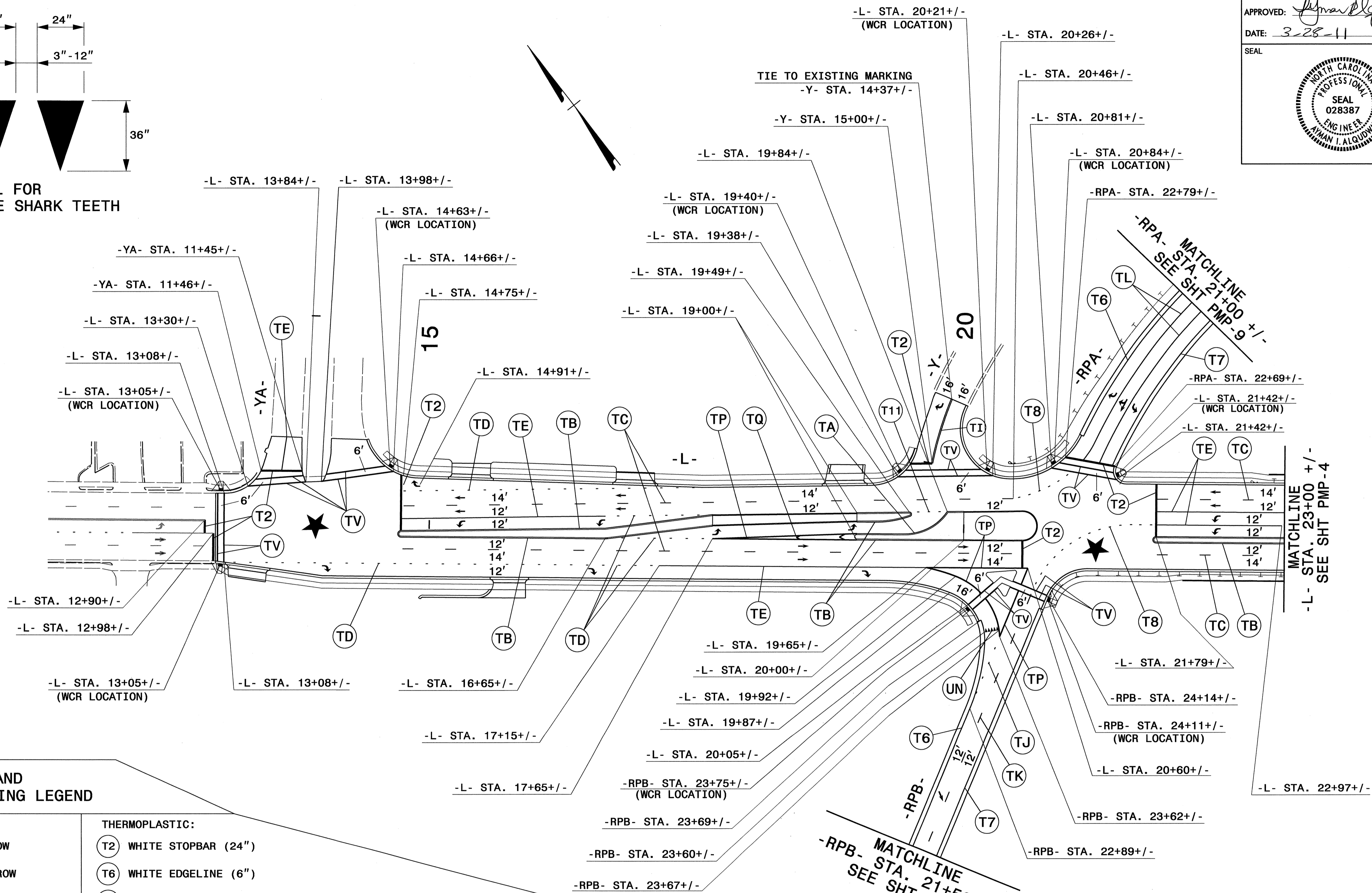

SYMBOL AND
PAVEMENT MARKING LEGEND

- THERMOPLASTIC:
- UA LEFT TURN ARROW
 - UB RIGHT TURN ARROW
 - UC STRAIGHT ARROW
 - UE COMBO STRAIGHT/RIGHT
 - UN 24" YIELD LINE TRIANGLE

- THERMOPLASTIC:
- T2 WHITE STOPBAR (24")
 - T6 WHITE EDGELINE (6")
 - T7 YELLOW EDGELINE (6")
 - T8 2 FT. - 8 FT./SP WHITE MINISKIP (4")
 - T11 2 FT. - 8 FT./SP YELLOW MINISKIP (4")
 - TA WHITE EDGELINE (4")
 - TB YELLOW EDGELINE (4")
 - TC 10 FT. WHITE SKIP (4")
 - TD 2 FT. 13 FT./SP WHITE MINISKIP (4")

- TE WHITE LANE LINE (4")
- TI YELLOW DOUBLE CENTER (4")
- TJ 10 FT. WHITE SKIP (6")
- TK 2 FT. - 13 FT./SP WHITE MINISKIP (6")
- TL WHITE LANE LINE (6")
- TP WHITE GORELINE (8")
- TQ WHITE DIAGONAL (8")
- TV WHITE CROSSWALK (8")

PAVEMENT MARKING DETAIL

25-MAR-2011 09:41
 C:\Users\jacob\AppData\Local\Temp\CADD\PMU-2550B_Sgn_PMP-3.dgn
 jacob

TIP NO. U-2550B	SHEET NO. PMP-4
APPROVED: <i>[Signature]</i>	
DATE: 3-7-11	
SEAL	

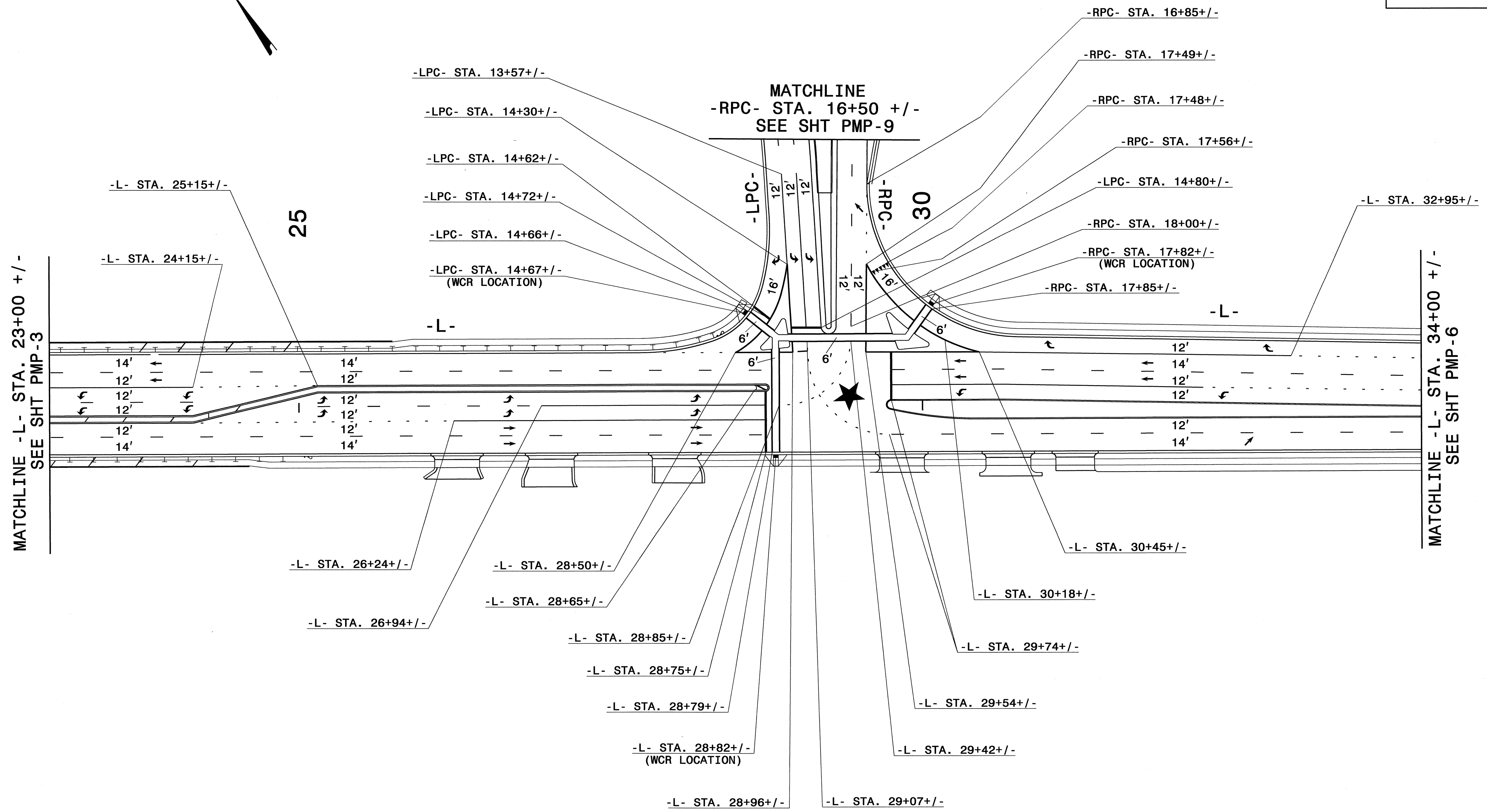

PAVEMENT MARKING DETAIL

TIP NO. U-2550B	SHEET NO. PMP-5
APPROVED: <i>[Signature]</i>	
DATE: 3-7-11	
SEAL	
	

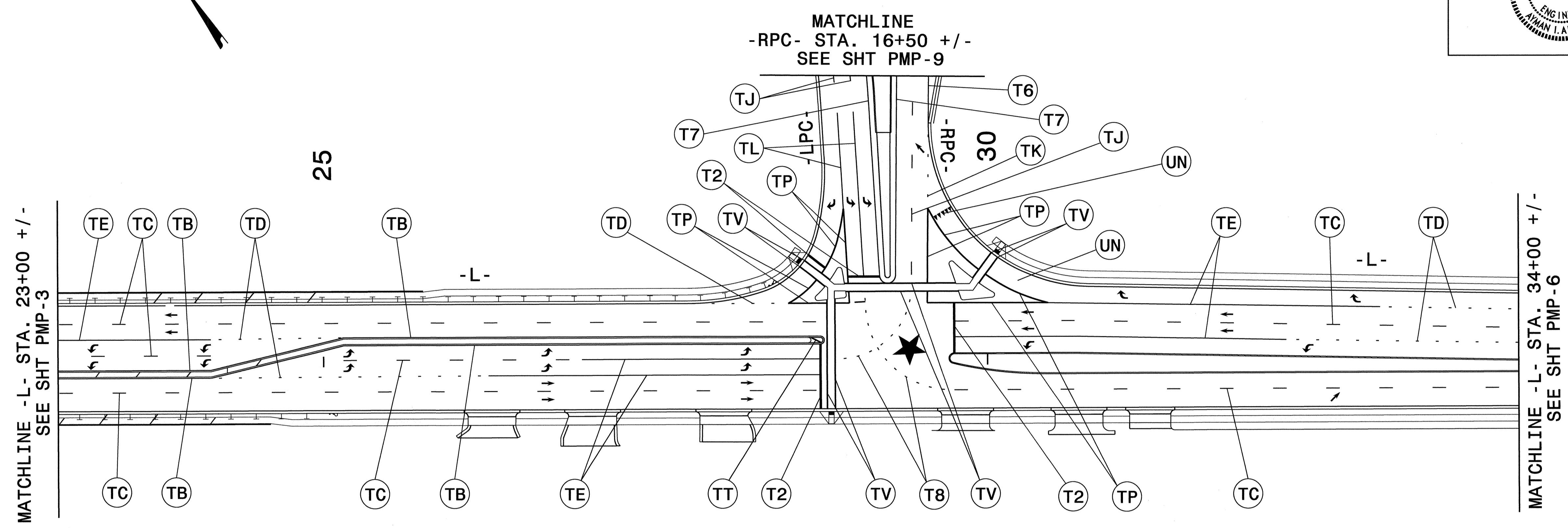

SYMBOL AND PAVEMENT MARKING LEGEND

<p>THERMOPLASTIC:</p> <ul style="list-style-type: none"> ↖ UA LEFT TURN ARROW ↗ UB RIGHT TURN ARROW → UC STRAIGHT ARROW ▼ UN 24" YIELD LINE TRIANGLE 	<p>THERMOPLASTIC:</p> <ul style="list-style-type: none"> (T2) WHITE STOPBAR (24") (T6) WHITE EDGELINE (6") (T7) YELLOW EDGELINE (6") (T8) 2 FT. - 8FT./SP. WHITE MINISKIP (4") (TB) YELLOW EDGELINE (4") (TC) 10 FT. WHITE SKIP (4") (TD) 2 FT. - 13 FT./SP. WHITE MINISKIP (4") (TE) WHITE LANE LINE (4") (TJ) 10' WHITE SKIP (6") (TK) 2 FT. - 13 FT./SP. WHITE MINISKIP (6") (TL) WHITE LANE LINE (6") (TP) WHITE GORELINE (8") (TT) YELLOW DIAGONAL (8") (TV) WHITE CROSSWALK LINE (8")
---	--

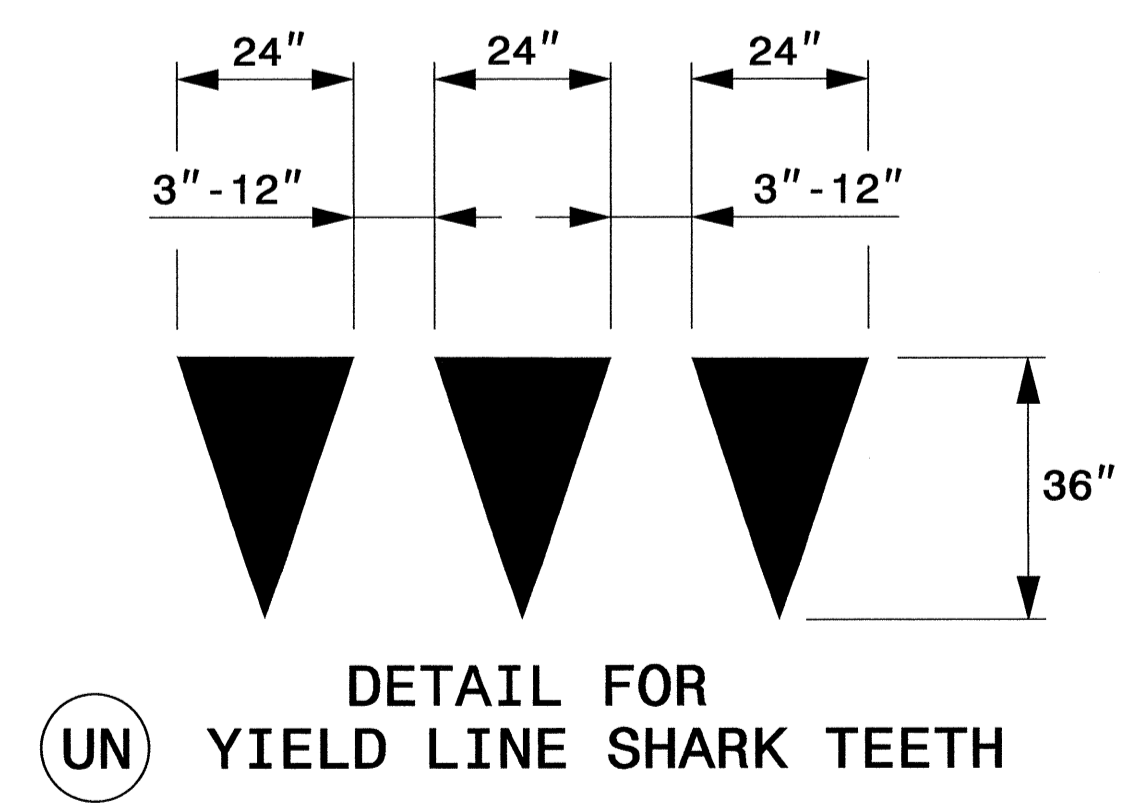

(UN) **DETAIL FOR YIELD LINE SHARK TEETH**

PAVEMENT MARKING DETAIL

04-MAR-2011 09:42
 C:\Users\chbeard\Documents\CADD\PMP-U-2550B-Sgn-PMP-5.dgn
 chbeard

TIP NO. U-2550B	SHEET NO. PMP-6
APPROVED: <i>[Signature]</i>	
DATE: 3-7-11	
SEAL	
	

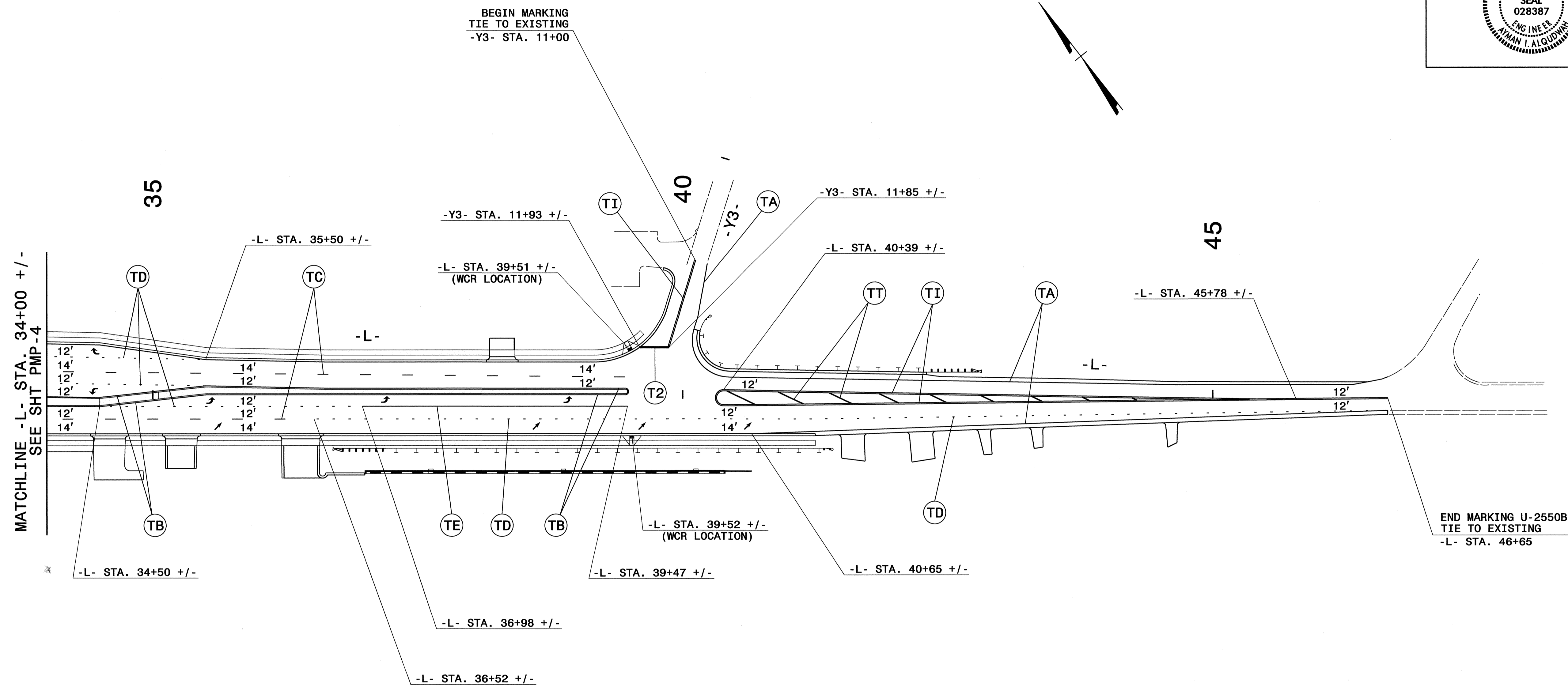

SYMBOL AND PAVEMENT MARKING LEGEND

THERMOPLASTIC:

- UA LEFT TURN ARROW
- UB RIGHT TURN ARROW
- UC STRAIGHT ARROW

THERMOPLASTIC:

- (T2) WHITE STOPBAR (24")
- (TA) WHITE EDGELINE (4")
- (TB) YELLOW EDGELINE (4")
- (TC) 10 FT. WHITE SKIP (4")
- (TD) 2 FT. - 13 FT./SP WHITE MINISKIP (4")
- (TE) WHITE LANE LINE (4")
- (TI) YELLOW DOUBLE CENTER (4")
- (TT) YELLOW DIAGONAL (8")

PAVEMENT MARKING DETAIL



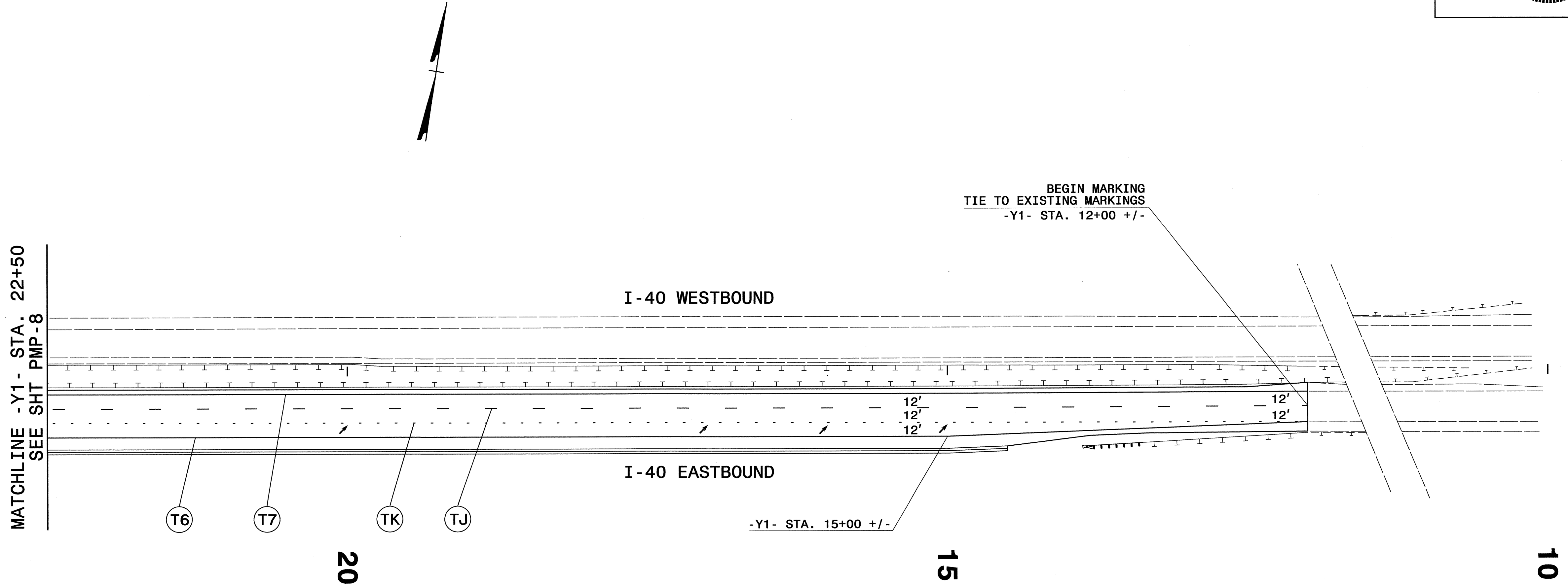

04-MAR-2011 09:43
 C:\Users\pmp6\Documents\CADD\PMU-U-2550B-Sgn-PMP-6.dgn
 pmp6.dwg

TIP NO. U-2550B	SHEET NO. PMP-7
APPROVED: <i>[Signature]</i>	
DATE: 3-7-11	
SEAL	
	



SYMBOL AND PAVEMENT MARKING LEGEND

THERMOPLASTIC:
 UC STRAIGHT ARROW

- THERMOPLASTIC:**
-  WHITE EDGELINE (6")
 -  YELLOW EDGELINE (6")
 -  10 FT. WHITE SKIP (6")
 -  2 FT. - 13 FT./SP WHITE MINISKIP (6")

PAVEMENT MARKING DETAIL

04-MAR-2011 09:44
 C:\MATT\cadd\CADD\PMU-2550B_Sgn_PMP_7.dgn
 jbeard

TIP NO. U-2550B	SHEET NO. PMP-8
APPROVED: <i>[Signature]</i>	
DATE: 3-7-11	
SEAL	

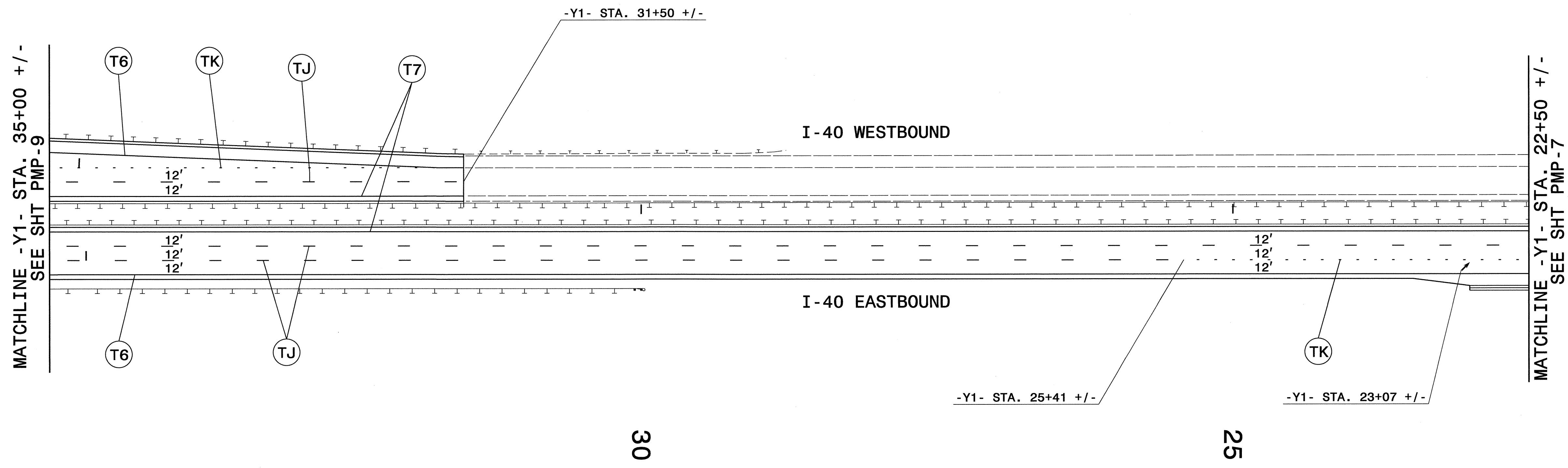

SYMBOL AND PAVEMENT MARKING LEGEND

THERMOPLASTIC:
 → UA STRAIGHT ARROW

THERMOPLASTIC:
 (T6) WHITE EDGELINE (6")
 (T7) YELLOW EDGELINE (6")
 (TJ) 10 FT. WHITE SKIP (6")
 (TK) 2 FT. - 13 FT./SP WHITE MINISKIP (6")

PAVEMENT MARKING DETAIL

04-MAR-2011 09:45
 c:\paw\cadd\pmp\U-2550B.Sgn_PMP-8.dgn
 chbeard

TIP NO. U-2550B	SHEET NO. PMP-9
APPROVED: <i>[Signature]</i>	
DATE: 3-7-11	
SEAL	
	

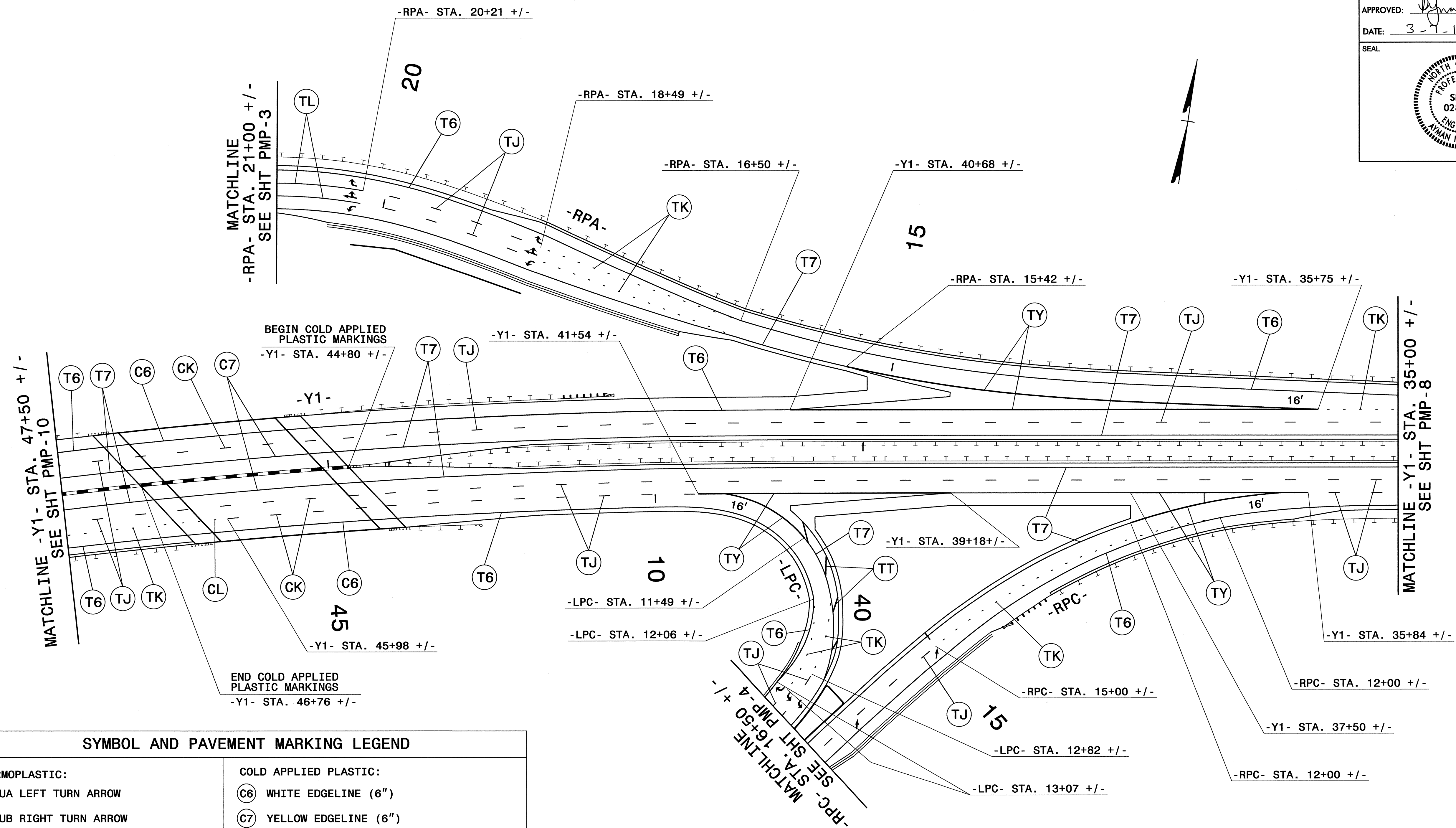

SYMBOL AND PAVEMENT MARKING LEGEND

<p>THERMOPLASTIC:</p> <ul style="list-style-type: none"> UA LEFT TURN ARROW UB RIGHT TURN ARROW UC STRAIGHT ARROW UE COMBO STRAIGHT/RIGHT ARROW 	<p>COLD APPLIED PLASTIC:</p> <ul style="list-style-type: none"> C6 WHITE EDGELINE (6") C7 YELLOW EDGELINE (6") CK 10 FT. WHITE SKIP (6") CL 2 FT. - 13 FT./SP WHITE MINISKIP (6") <p>THERMOPLASTIC:</p> <ul style="list-style-type: none"> T6 WHITE EDGELINE (6") T7 YELLOW EDGELINE (6") TJ 10 FT. WHITE SKIP (6") TK 2 FT. - 13 FT./SP WHITE MINISKIP (6") TL WHITE LANE LINE (6") TT YELLOW DIAGONAL (8") TY WHITE GORELINE (12")
--	---

PAVEMENT MARKING DETAIL

04-MAR-2011 09:45
 C:\MAR-2011\CADD\PMU-2550B_Sgn_PMP-9.dgn
 chbeard

TIP NO. U-2550B	SHEET NO. PMP-10
APPROVED: <i>[Signature]</i>	
DATE: 3-7-11	
SEAL	

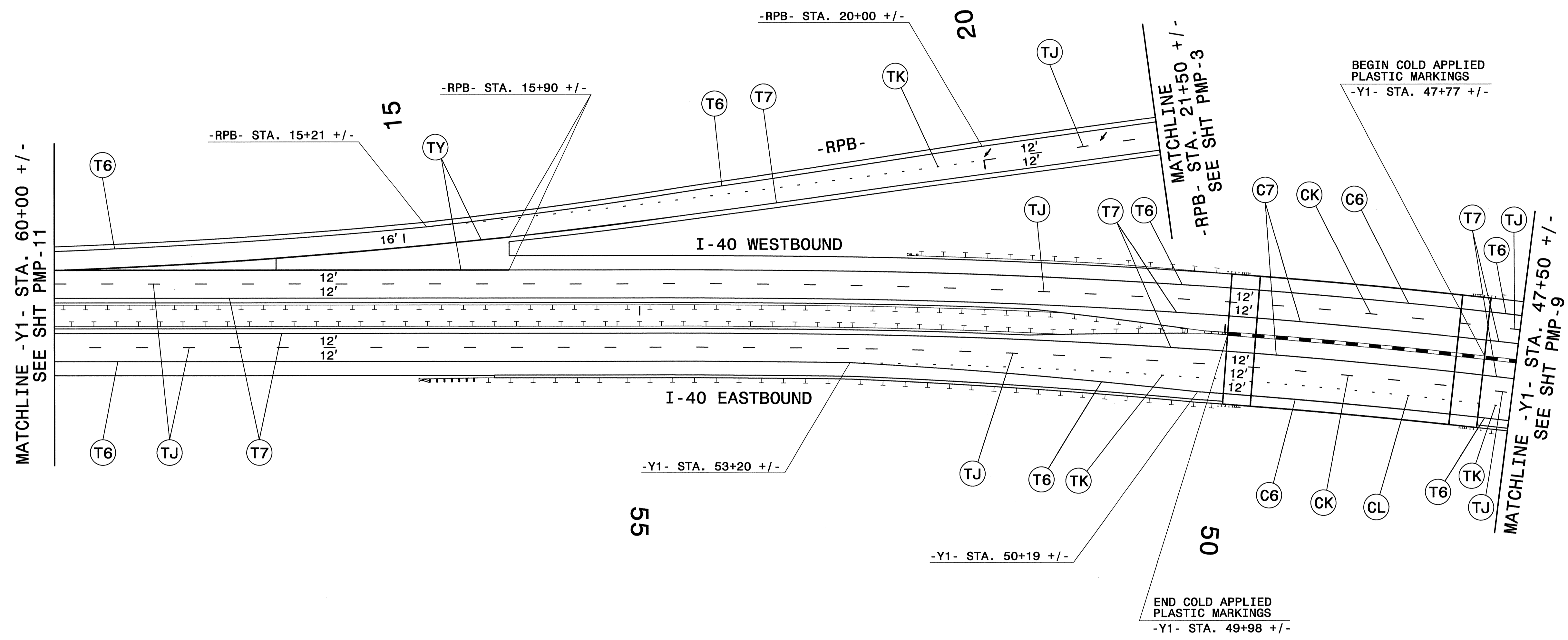

SYMBOL AND PAVEMENT MARKING SCHEDULE

<p>THERMOPLASTIC:</p> <p>← UC STRAIGHT ARROW</p>	<p>COLD APPLIED PLASTIC (TYPE III):</p> <p>(C6) WHITE EDGELINE (6")</p> <p>(C7) YELLOW EDGELINE (6")</p> <p>(CK) 10 FT. WHITE SKIP (6")</p> <p>(CL) 2 FT. - 13 FT./SP WHITE MINISKIP (6")</p> <p>THERMOPLASTIC:</p> <p>(T6) WHITE EDGELINE (6")</p> <p>(T7) YELLOW EDGELINE (6")</p> <p>(TJ) 10 FT. WHITE SKIP (6")</p> <p>(TK) 2 FT. - 13 FT./SP WHITE MINISKIP (6")</p> <p>(TY) WHITE GORELINE (12")</p>
---	--

PAVEMENT MARKING DETAIL



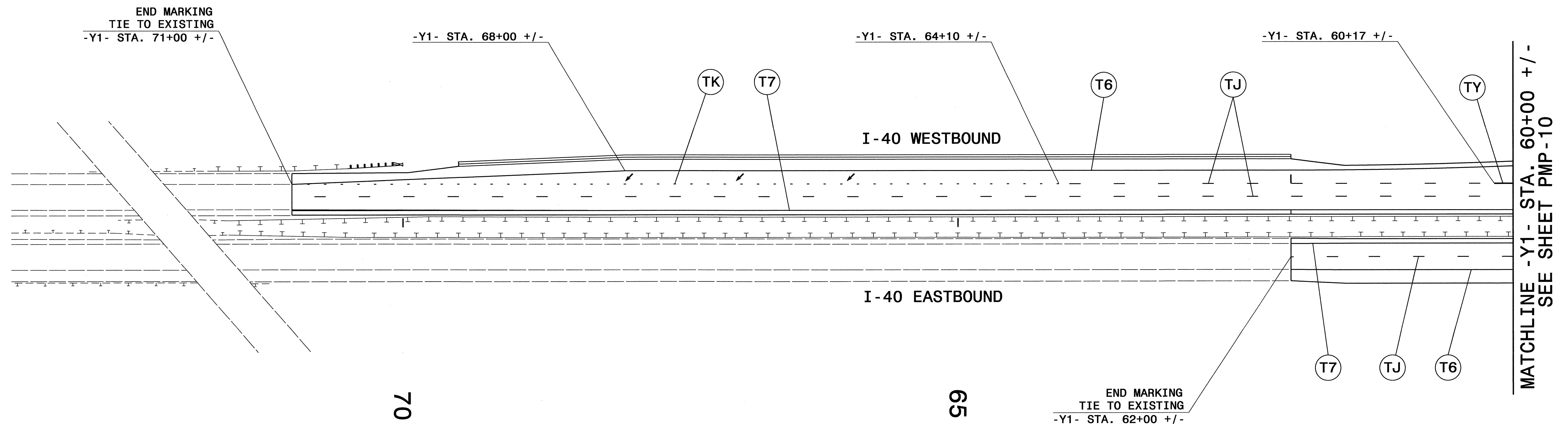

04-MAR-2011 09:46
 C:\JAF\2011\CADD\PMU-U-2550B-Sgn-PMP-10.dgn
 chbeard

TIP NO. U-2550B	SHEET NO. PMP-11
APPROVED: <i>[Signature]</i>	
DATE: 3-7-11	
SEAL	
	



SYMBOL AND PAVEMENT MARKING LEGEND

THERMOPLASTIC:
 UC STRAIGHT ARROW

- THERMOPLASTIC:**
-  WHITE EDGELINE (6")
 -  YELLOW EDGELINE (6")
 -  10 FT. WHITE SKIP (6")
 -  2 FT. - 13 FT./SP WHITE MINISKIP (6")
 -  WHITE GORELINE (12")

PAVEMENT MARKING DETAIL

04-MAR-2011 09:47
 C:\MAR_2011\09_47\IC\101\101.dgn
 chbeard