

CONTRACT: 700009462 TIP PROJECT: U-2826B

**NORTH CAROLINA
DEPARTMENT OF TRANSPORTATION**

FORSYTH COUNTY

TYPE OF WORK: INSTALLATION OF FIBER OPTIC CABLE AND WIRELESS
ETHERNET NETWORK, CCTV CAMERAS, DYNAMIC MESSAGE SIGNS,
MICROWAVE VEHICLE DETECTORS AND TRUCK ROLLOVER SYSTEM

STATE	STATE PROJECT REFERENCE NO.	SHEET NO.	TOTAL SHEETS
N.C.	U-2826B	ITS-1	
STATE PROJ. NO.	F.A. PROJ. NO.	DESCRIPTION	

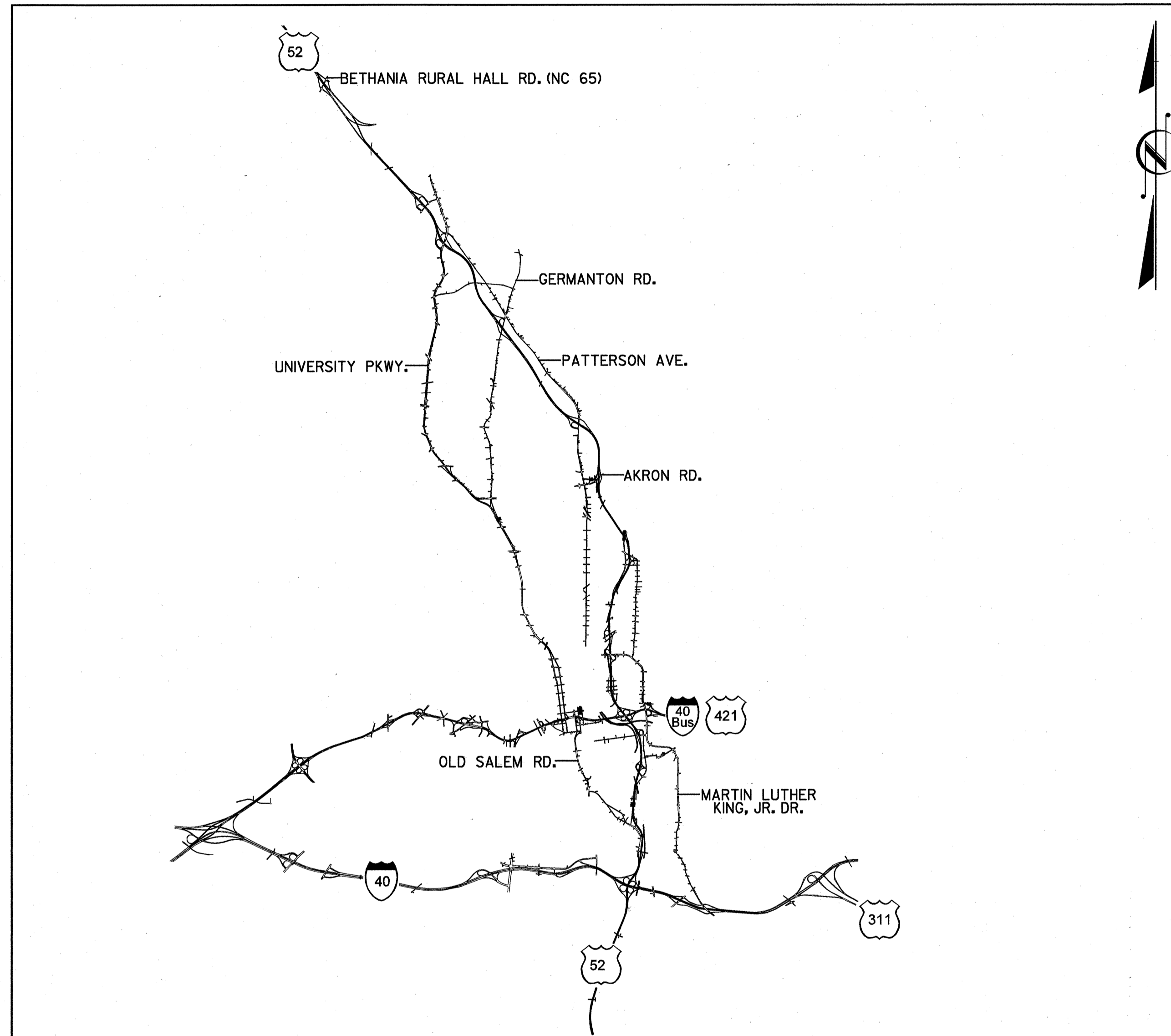
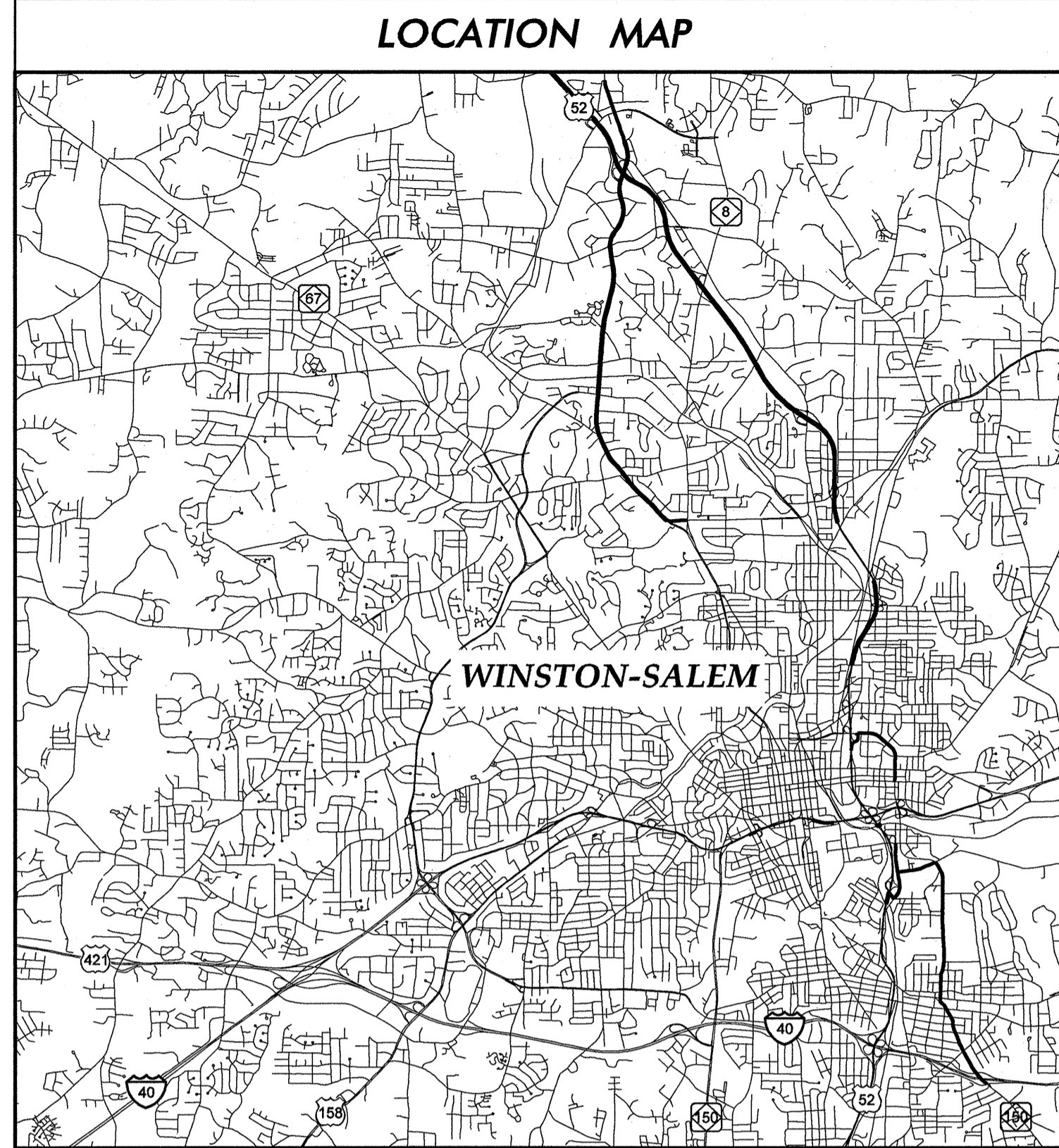

FINAL PLANS

INDEX OF PLANS

SHEET NUMBER	DESCRIPTION
1	TITLE SHEET
1A	CONSTRUCTION NOTES
1B-1C	PLAN KEY
2-2L	DETAILS
3	QUANTITIES
4-82	CABLE ROUTING PLANS
SPLI-66	SPLICE DETAIL

ROADWAY STANDARD DRAWINGS

THE FOLLOWING ROADWAY STANDARDS AS APPEAR IN "ROADWAY STANDARD DRAWINGS" - ROADWAY DESIGN UNIT - N.C. DEPARTMENT OF TRANSPORTATION - RALEIGH, N.C., DATED JULY 2006 ARE APPLICABLE TO THIS PROJECT AND BY REFERENCE HEREBY ARE CONSIDERED A PART OF THESE PLANS:

STD. NUMBER	DESCRIPTION
1700.01	ELECTRICAL SERVICE OPTIONS
1700.02	ELECTRICAL SERVICE GROUNDING
1715.01	UNDERGROUND CONDUIT
1716.01	JUNCTION BOXES
1720.01	WOOD POLES
1721.01	GUY ASSEMBLIES
1730.01	FIBER OPTIC SPARE CABLE STORAGE

LETTING DATE:

APRIL 19, 2011

PROJECT LENGTH

PROJECT LENGTH = 31 MILES

DEPARTMENT OF TRANSPORTATION
FEDERAL HIGHWAY ADMINISTRATION

APPROVED _____ DATE _____
DIVISION ADMINISTRATOR

DIVISION OF HIGHWAYS
STATE OF NORTH CAROLINA

STATE DESIGN ENGINEER _____ P. E.

PLANS PREPARED BY:

**Kimley-Horn
and Associates, Inc.**
NC License #F-0102
P.O. Box 33068
Raleigh, NC 27636
(919) 671-2000

KIMLEY-HORN CONTACTS:
STEPHANIE B. PRIVETTE, P.E. - PROJECT MANAGER

NCDOT CONTACTS:
TRANSPORTATION MOBILITY AND SAFETY DIVISION
THOMAS G. PARKER - ITS PROJECT ENGINEER
SHERRY C. YOW - PROJECT DESIGN ENGINEER

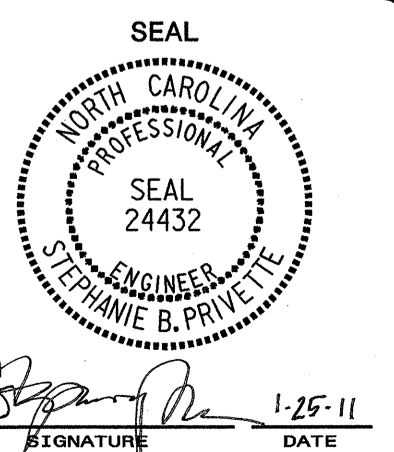
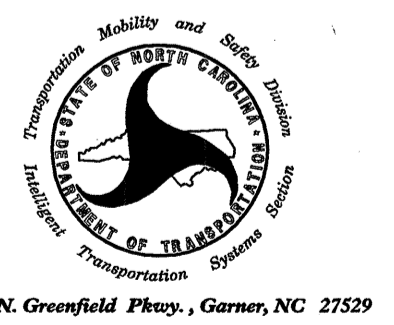

- 1 INSTALL REA, PE - 22, SHIELDED, TWISTED PAIR COMMUNICATIONS CABLE
- 2 INSTALL REA, PE - 38, (FIGURE - 8) SHIELDED, TWISTED PAIR COMMUNICATIONS CABLE
- 3 INSTALL REA, PE - 39, (UNDERGROUND) SHIELDED, TWISTED PAIR COMMUNICATIONS CABLE
- 4 INSTALL SMFO CABLE
- 5 INSTALL ETHERNET CABLE
- 6 INSTALL FIBER OPTIC DROP CABLE
- 7 INSTALL TRACER WIRE
- 8 TRENCH
- 9 INSTALL PVC CONDUIT
- 10 INSTALL RIGID, GALVANIZED STEEL CONDUIT
- 11 INSTALL RIGID, GALVANIZED STEEL RISER WITH WEATHERHEAD
- 12 INSTALL RIGID, GALVANIZED STEEL RISER WITH FIBER OPTIC CABLE SEAL
- 13 INSTALL OUTER-DUCT POLYETHYLENE CONDUIT
- 14 INSTALL POLYETHYLENE CONDUIT
- 15 DIRECTIONAL DRILL CONDUIT
- 16 BORE AND JACK CONDUIT
- 17 INSTALL CABLE(S) IN EXISTING CONDUIT
- 18 INSTALL CABLE(S) IN NEW CONDUIT
- 19 INSTALL CABLE(S) IN EXISTING RISER
- 20 INSTALL CABLE(S) IN NEW RISER
- 21 INSTALL CABLE(S) IN EXISTING CONDUIT STUBOUTS
- 22 INSTALL NEW CONDUIT INTO EXISTING CABINET BASE (USE EXISTING CONDUIT STUB-OUTS WHEN AVAILABLE)
- 23 INSTALL NEW RISER INTO EXISTING CABINET BASE (USE EXISTING CONDUIT STUB-OUTS WHEN AVAILABLE)
- 24 INSTALL NEW CONDUIT INTO EXISTING POLE MOUNTED CABINET
- 25 INSTALL NEW RISER INTO EXISTING POLE MOUNTED CABINET
- 26 TERMINATE COMMUNICATIONS CABLE ON EXISTING TELEMETRY INTERFACE PANEL IN TRAFFIC SIGNAL CONTROLLER CABINET
- 27 MODIFY EXISTING SPLICE CABINET/ENCLOSURE
- 28 INSTALL INTERCONNECT CENTER, PATCH PANEL, JUMPERS, AND FUSION SPLICE CABLE IN CABINET
- 29 INSTALL UNDERGROUND SPLICE ENCLOSURE
- 30 INSTALL AERIAL SPLICE ENCLOSURE
- 31 INSTALL POLE MOUNTED SPLICE CABINET
- 32 INSTALL BASE MOUNTED SPLICE CABINET
- 33 REMOVE EXISTING SPLICE CABINET
- 34 INSTALL CABINET FOUNDATION

- 35 REMOVE EXISTING CABINET FOUNDATION
- 36 INSTALL CCTV CAMERA ASSEMBLY
- 37 INSTALL CCTV CAMERA WOOD POLE
- 38 INSTALL SPECIAL SIZED JUNCTION BOX
- 39 INSTALL JUNCTION BOX
- 40 INSTALL OVERSIZED JUNCTION BOX
- 41 REMOVE EXISTING JUNCTION BOX
- 42 INSTALL WOOD POLE
- 43 REMOVE EXISTING WOOD POLE
- 44 INSTALL AERIAL GUY ASSEMBLY
- 45 INSTALL STANDARD GUY ASSEMBLY
- 46 INSTALL SIDEWALK GUY ASSEMBLY
- 47 INSTALL MESSENGER CABLE
- 48 REMOVE EXISTING COMMUNICATIONS CABLE AND MESSENGER CABLE
- 49 REMOVE EXISTING COMMUNICATIONS CABLE
- 50 INSTALL TELEPHONE SERVICE
- 51 INSTALL CABLE STORAGE RACKS (SNOW SHOES) AND STORE 100 FEET OF EACH CABLE
- 52 INSTALL DELINEATOR MARKER
- 53 STORE 30 FEET OF EACH COMMUNICATIONS CABLE
- 54 LASH CABLE(S) TO EXISTING SIGNAL/COMMUNICATIONS CABLE
- 55 LASH CABLE(S) TO EXISTING MESSENGER CABLE
- 56 LASH CABLE(S) TO NEW MESSENGER CABLE
- 57 MODIFY EXISTING ELECTRICAL SERVICE
- 58 INSTALL NEW ELECTRICAL SERVICE
- 59 INSTALL ETHERNET EDGE SWITCH
- 60 INSTALL VIDEO ENCODER
- 61 INSTALL WOOD MVD POLE
- 62 INSTALL MYD ASSEMBLY
- 63 INSTALL EQUIPMENT CABINET
- 64 INSTALL DMS ASSEMBLY
- 65 INSTALL ISOLATION TRANSFORMER
- 66 INSTALL UNI-DIRECTIONAL ANTENNA
- 67 INSTALL OMNI-DIRECTIONAL ANTENNA
- 68 INSTALL 2.45.8 GHz RADIO UNIT
- 69 INSTALL 900 MHz RADIO UNIT

LEGEND

	NEW FIBER OPTIC COMMUNICATIONS CABLE
	NEW DIRECTIONAL DRILLED CONDUIT
	NEW CONDUIT
	NEW JUNCTION BOX
	EXISTING JUNCTION BOX
	NEW WOOD POLE
	EXISTING WOOD POLE
	EXISTING METAL POLE
	NEW STANDARD GUY ASSEMBLY
	NEW STANDARD GUY ASSEMBLY
	NEW CABLE STORAGE RACKS (SNOW SHOES)
	NEW AERIAL SPLICE ENCLOSURE
	EXISTING AERIAL SPLICE ENCLOSURE
	UNDERGROUND SPLICE ENCLOSURE
	EXISTING CONTROLLER AND CABINET
	EXISTING SPLICE CABINET
	NEW CCTV ASSEMBLY
	EXISTING CCTV ASSEMBLY
	EXISTING OVERHEAD DMS AND SIGN STRUCTURE
	EXISTING OVERHEAD DMS AND SIGN STRUCTURE
	NEW PEDESTAL MOUNTED DMS AND SIGN STRUCTURE
	EXISTING PEDESTAL MOUNTED DMS AND SIGN STRUCTURE
	NEW MICROWAVE VEHICLE DETECTOR ASSEMBLY
	NEW WIRELESS TRANSCEIVER AND ANTENNA
	EXISTING GUARDRAIL
	NEW GUARDRAIL (BY OTHERS)

CONSTRUCTION NOTE SYMBOLOGY KEY

- INDICATES NUMBER OF CABLES, LOOPS, ETC.
- INDICATES NUMBER OF FIBERS PER CABLE, TWISTED PAIRS PER CABLE, ETC.
- INDICATES NUMBER OF RISER(S)/CONDUIT(S)
- INDICATES DIAMETER OF RISER(S)/CONDUIT(S) (INCH)

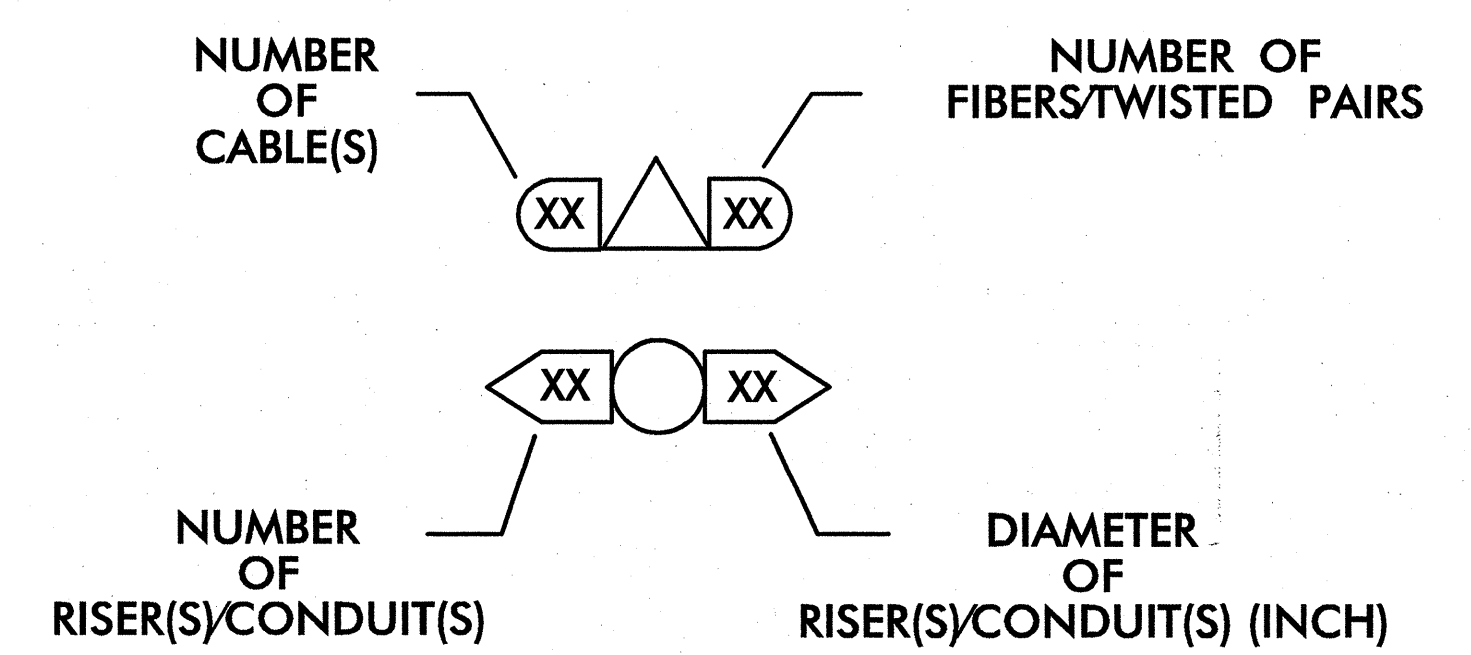

K:\RAL_T770_ITS\01106188-US 52 ITS (U-2826B)\Plan_Sht_001A.dgn
 1/25/2011 12:52:47 PM JERRY CROSS

PLANS PREPARED IN THE OFFICE OF:





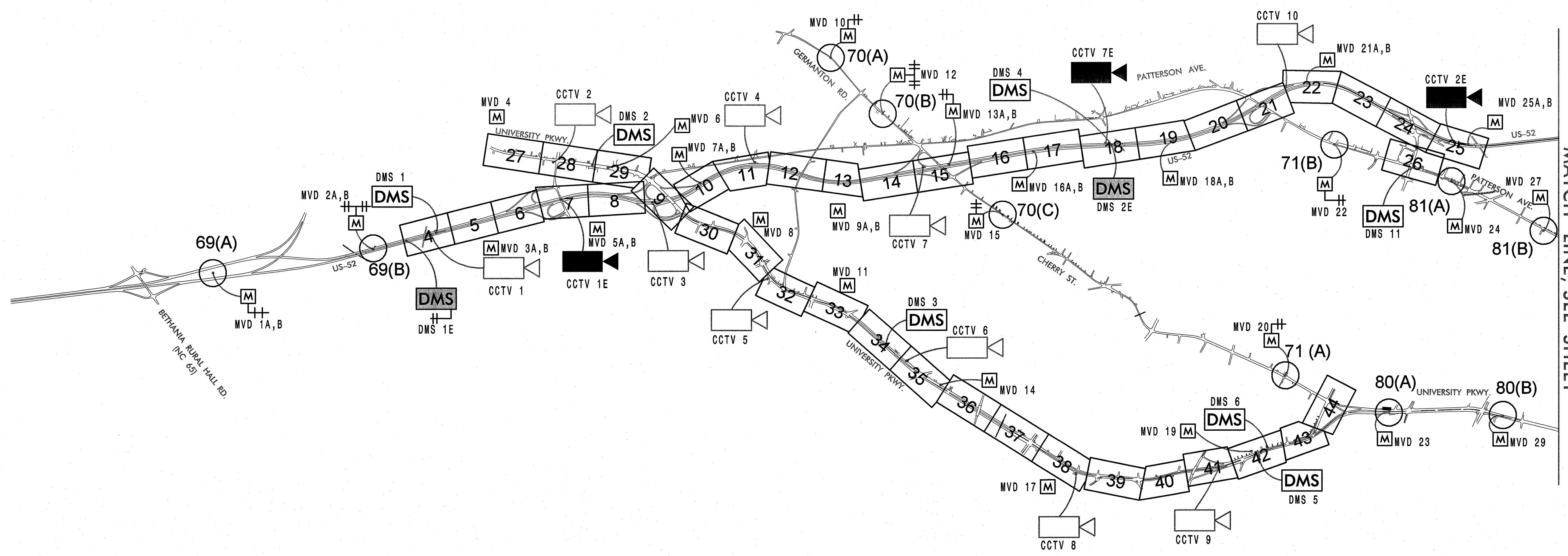

Kimley-Horn and Associates, Inc.
 P.O. Box 33068
 Raleigh, N.C. 27636-3068
 (919) 677-2000
 N.C. License # F-0102

	U-2826B		
	CONSTRUCTION NOTES AND LEGEND		
	DIVISION 9 FORSYTH COUNTY WINSTON SALEM	PLANNING	
PREPARED BY: J. Cross	REVIEWED BY: S. Privette	DATE	DATE
REVISIONS	INIT.	DATE	DATE

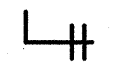

MATCH LINE, SEE SHEET

KEY

-  WIRELESS RADIO ANTENNA
-  MVD
-  PROPOSED DMS
-  EXISTING DMS
-  PROPOSED CCTV
-  EXISTING CCTV

1/25/2011 11:45:47 AM jerry.cross k:\ral_tpro_its\0108158-us_52_1ts (U-2826B)\plan_sht_001b.dgn

PLANS PREPARED IN THE OFFICE OF:

Kimley-Horn and Associates, Inc.
 P.O. Box 33068
 Raleigh N.C. 27636-3068
 (919) 677-2000
 N.C. License # F-0102

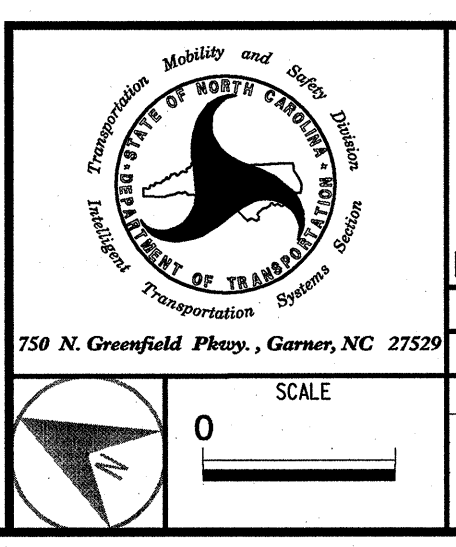

U-2826B	
CABLE ROUTING PLAN SHEET	
DIVISION 9 FORSYTH COUNTY WINSTON SALEM	
PLAN DATE: JANUARY 2011	REVIEWED BY:
PREPARED BY: J. CROSS	REVIEWED BY: S. Privette
REVISIONS	INIT. DATE

SEAL

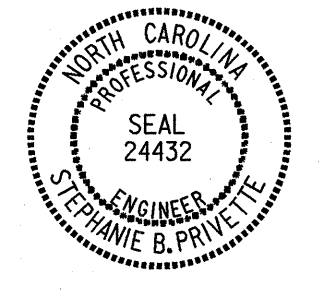

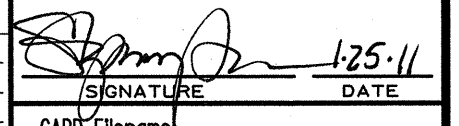
 SIGNATURE DATE 1-25-11
 CADD Filename

MATCH LINE,
SEE SHEET 1B

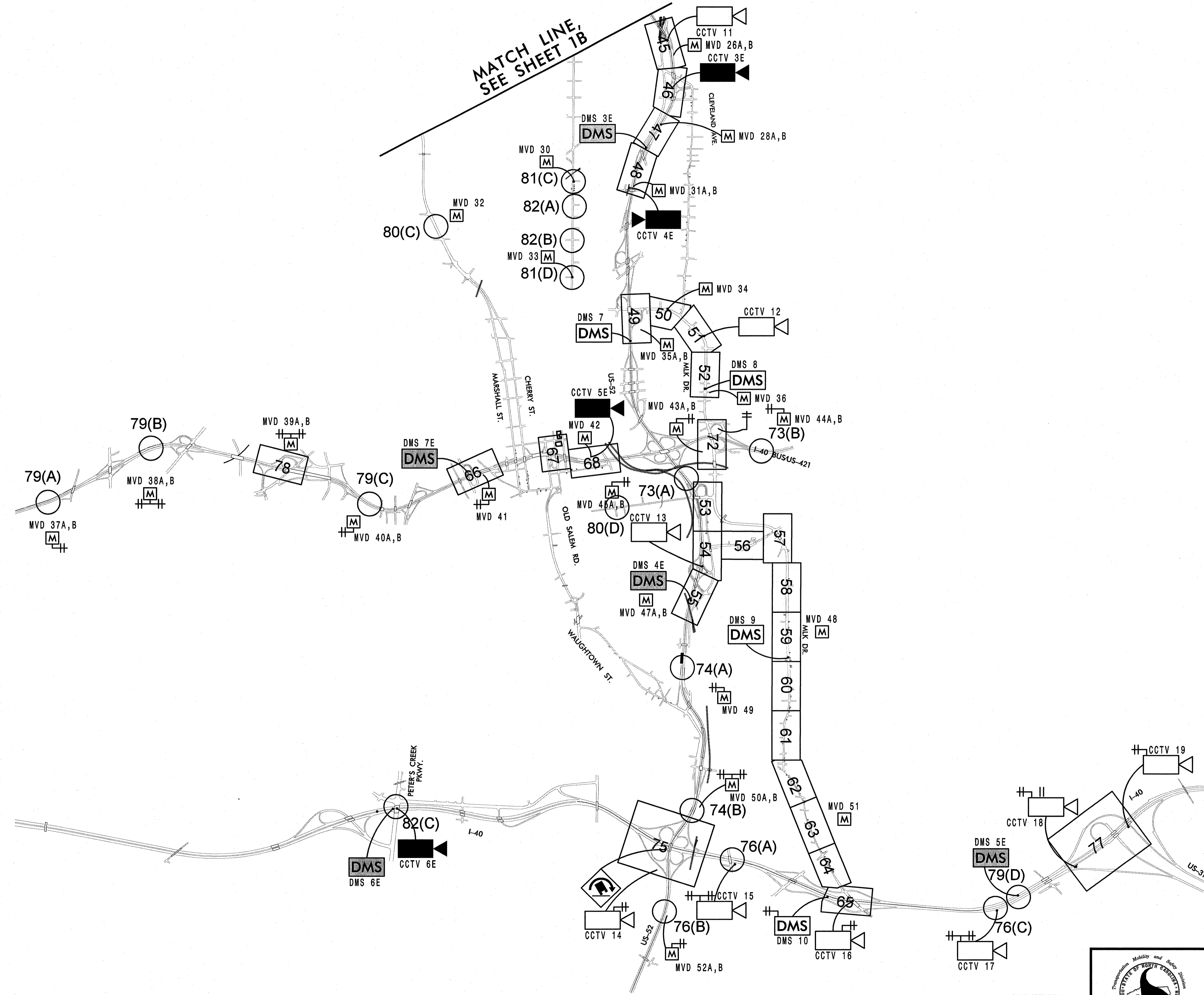

- KEY**
- WIRELESS RADIO ANTENNA
 - MVD
 - PROPOSED DMS
 - EXISTING DMS
 - PROPOSED CCTV
 - EXISTING CCTV
 - PROPOSED TRUCK ROLLOVER WARNING SYSTEM

1/25/2011 11:45:48 AM jerry.cross k:\val_tproj_its\01086158-us 82_its (u-2826B)\plan\shet_001c.dgn

PLANS PREPARED IN THE OFFICE OF:

Kimley-Horn and Associates, Inc.
 P.O. Box 33068
 Raleigh N.C. 27636-3068
 (919) 677-2000
 N.C. License # F-0102

750 N. Greenfield Pkwy., Garner, NC 27529

U-2826B	
CABLE ROUTING PLAN SHEET	
DIVISION 9 FORSYTH COUNTY WINSTON SALEM	
PLAN DATE: JANUARY 2011	REVIEWED BY:
PREPARED BY: J. Cross	REVIEWED BY: S. Privette
REVISIONS	INIT. DATE

SEAL

STEPHANIE B. PRIVETTE
 ENGINEER
 STATE OF NORTH CAROLINA
 LICENSE NO. 24432

1-25-11
 DATE

CADD Filenames

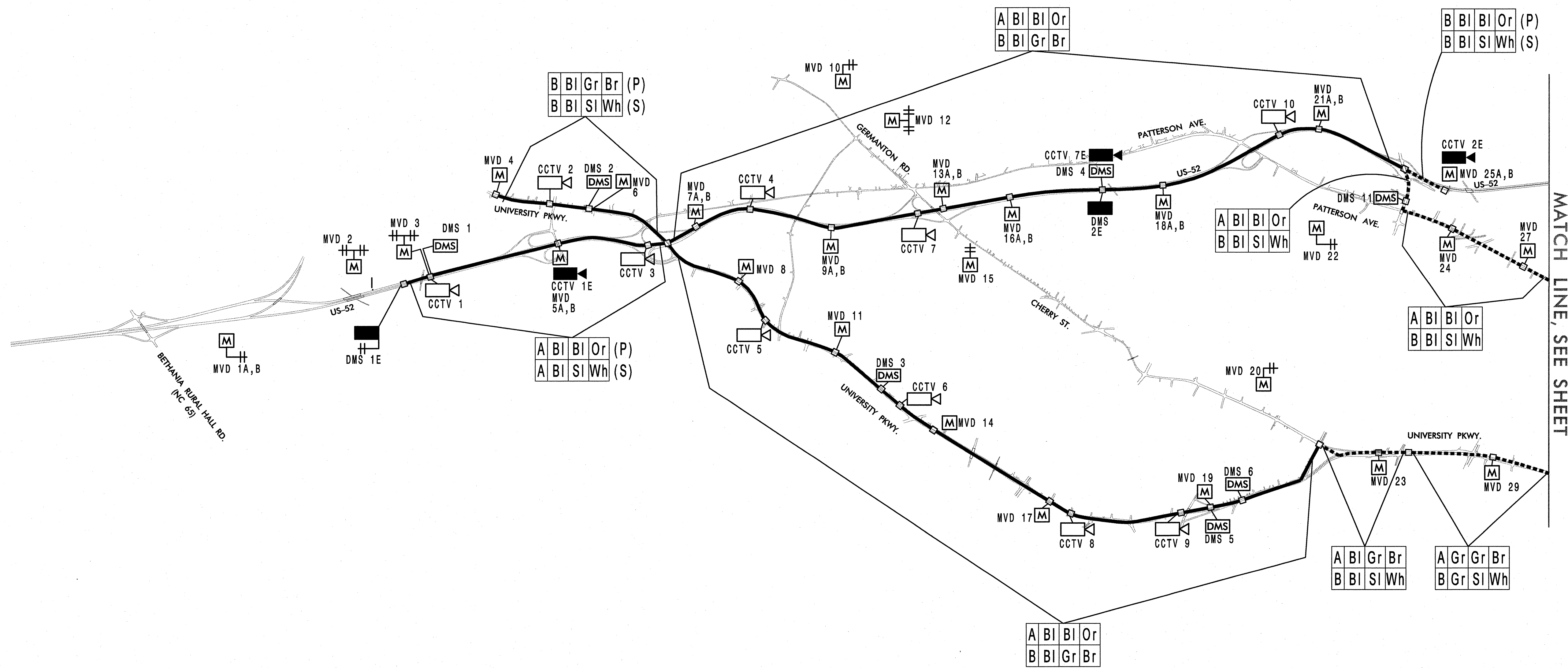

MATCH LINE, SEE SHEET

KEY		BUFFER TUBE/FIBER COLOR CODE			
	WIRELESS RADIO ANTENNA	Bl=BLUE	Re=RED		
	MVD	Or=ORANGE	Bk=BLACK		
	PROPOSED DMS	Gr=GREEN	Ye=YELLOW		
	EXISTING DMS	Br=BROWN	Vi=VIOLET		
	PROPOSED CCTV	Sl=SLATE	Ro=ROSE		
	EXISTING CCTV	Wh=WHITE	Aq=AQUA		
	NEW FOC	FOC LABEL KEY			
	EXISTING FOC	RING NAME	BUFFER TUBE COLOR	FIBER 1 COLOR	FIBER 2 COLOR
		(P)	PRIMARY		
		(S)	SECONDARY		

1/25/2011 11:45:50 AM jerty.cross k:\ra\proj_its\011036158-us_52_1ts (U-2826B)\plan\sh1 002.dgn

PLANS PREPARED IN THE OFFICE OF:

Kimley-Horn and Associates, Inc.
 P.O. Box 33068
 Raleigh, N.C. 27636-3068
 (919) 677-2000
 N.C. License # F-0102

 750 N. Greenfield Pkwy., Garner, NC 27529
 SCALE: 0' = 1"

U-2826B
RING A, B & C
CABLE ROUTING OVERVIEW

DIVISION 9 FORSYTH COUNTY WINSTON SALEM

PLAN DATE: JANUARY 2011	REVIEWED BY:
PREPARED BY: J. Cross	REVIEWED BY: S. Privette
REVISIONS	INIT. DATE

SEAL

STEPHANIE B. PRIVETTE
 ENGINEER
 DATE: 1/25/11
 CADD Filename:

MATCH LINE,
SEE SHEET 2

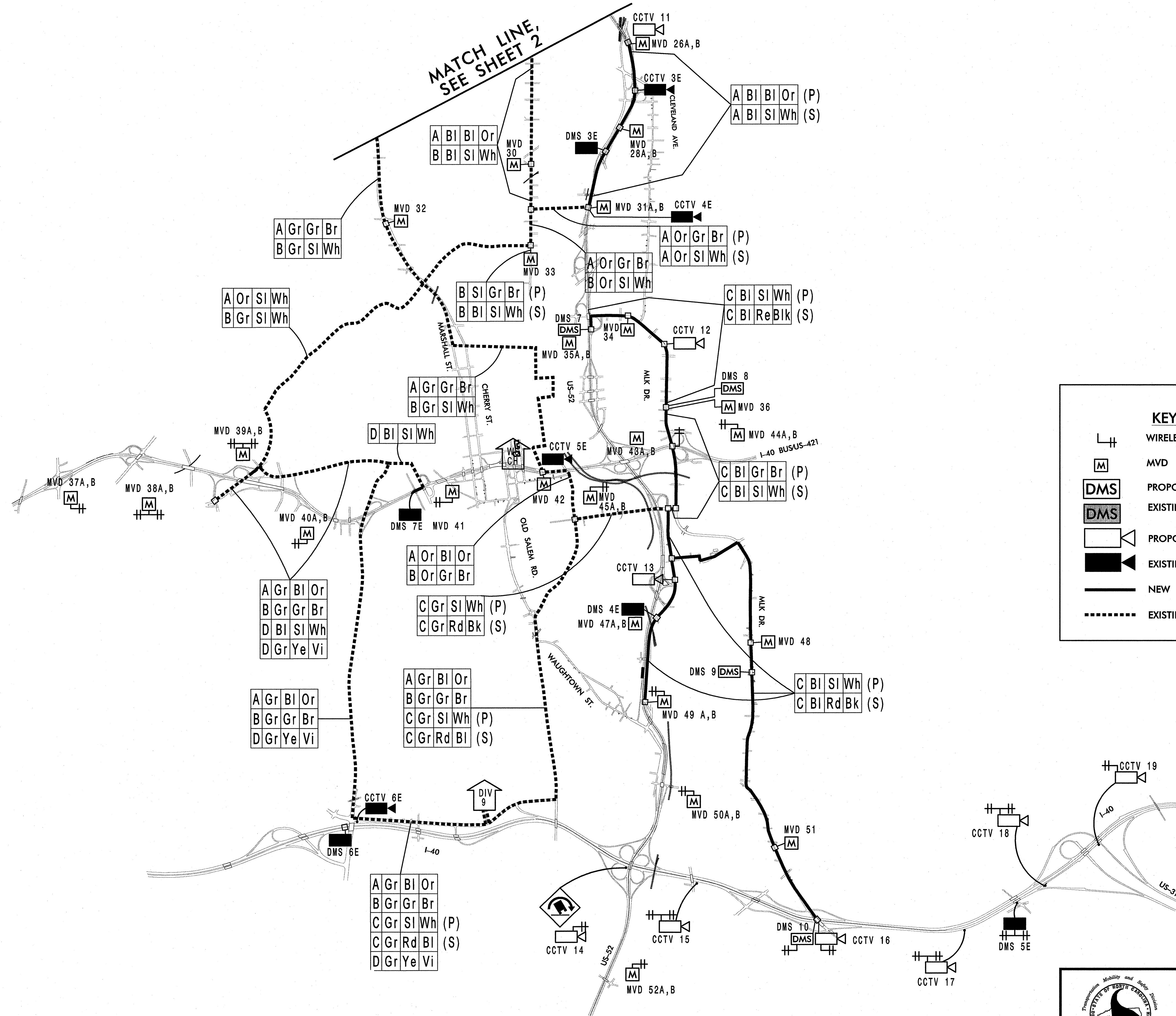

KEY		BUFFER TUBE/FIBER COLOR CODE			
	WIRELESS RADIO ANTENNA	Bl=BLUE	Re=RED		
	MVD	Or=ORANGE	Bk=BLACK		
	PROPOSED DMS	Gr=GREEN	Ye=YELLOW		
	EXISTING DMS	Br=BROWN	Vi=VIOLET		
	PROPOSED CCTV	Sl=SLATE	Ro=ROSE		
	EXISTING CCTV	Wh=WHITE	Aq=AQUA		
	NEW FOC				
	EXISTING FOC				

FOC LABEL KEY			
RING NAME	BUFFER TUBE COLOR	FIBER 1 COLOR	FIBER 2 COLOR
		(P) PRIMARY	
		(S) SECONDARY	

k:\na\trp\tsa\01106188-us 52.tss (U-2826B)\plan\sh1 002a.dgn
 2:57:59 PM
 jerry.cross
 1/26/2011

PLANS PREPARED IN THE OFFICE OF:

Kimley-Horn and Associates, Inc.
 P.O. Box 33068
 Raleigh N.C. 27636-3068
 (919) 677-2000
 N.C. License # F-002

750 N. Greenfield Pkwy., Garner, NC 27529

U-2826B			
RING A, B & C			
CABLE ROUTING OVERVIEW			
DIVISION 9 FORSYTH COUNTY		WINSTON SALEM	
PLAN DATE: JANUARY 2011	REVIEWED BY:		
PREPARED BY: J. Cross	REVIEWED BY: S. Privette		
REVISIONS	INIT.	DATE	

SEAL

STEPHANIE B. PRIVETTE
 ENGINEER
 SEAL 24432

DATE: 1-26-11

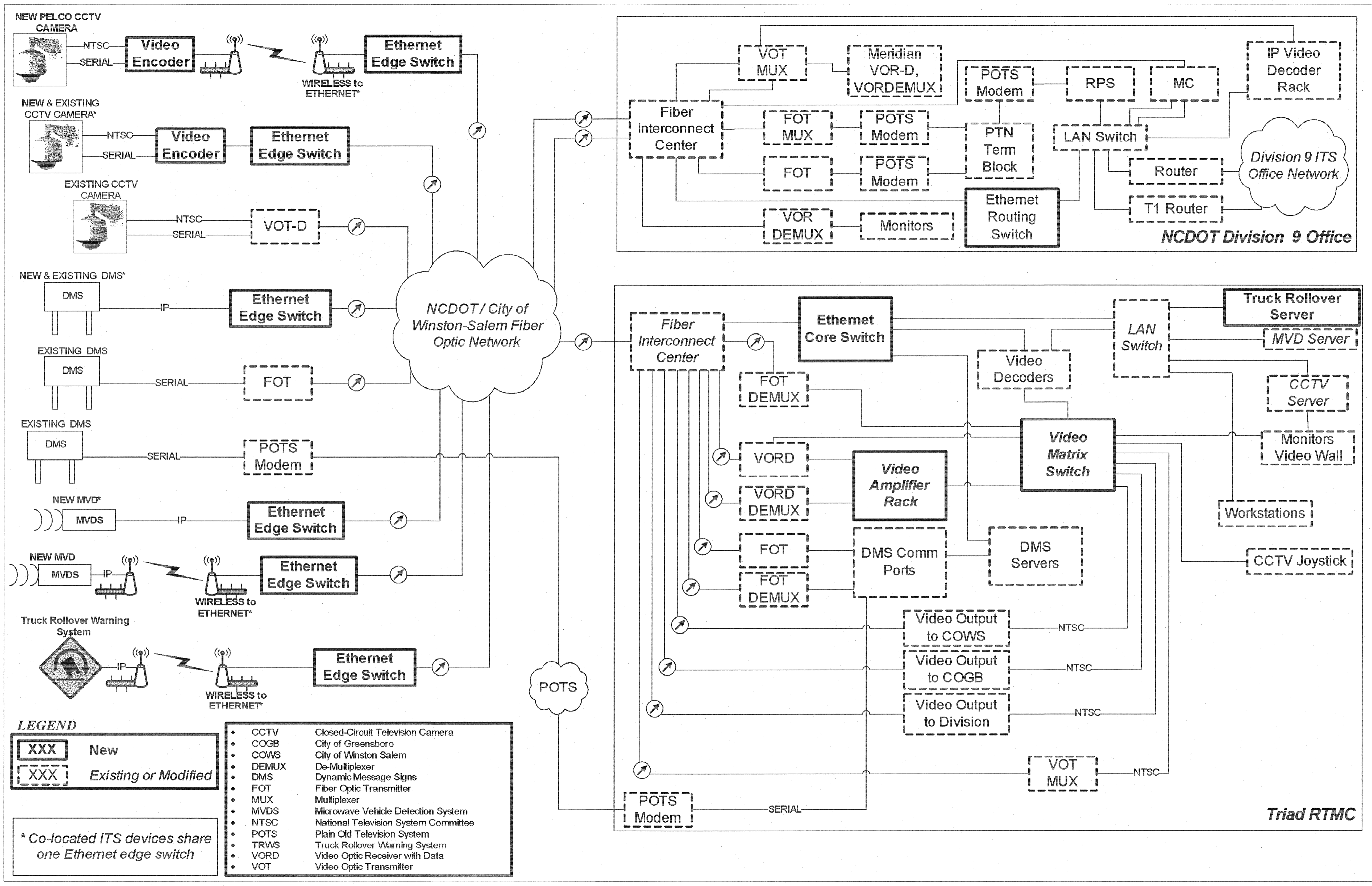

LEGEND

XXX	New
XXX	Existing or Modified

* Co-located ITS devices share one Ethernet edge switch

• CCTV	Closed-Circuit Television Camera
• COGB	City of Greensboro
• COWS	City of Winston Salem
• DEMUX	De-Multiplexer
• DMS	Dynamic Message Signs
• FOT	Fiber Optic Transmitter
• MUX	Multiplexer
• MVDS	Microwave Vehicle Detection System
• NTSC	National Television System Committee
• POTS	Plain Old Television System
• TRWS	Truck Rollover Warning System
• VORD	Video Optic Receiver with Data
• VOT	Video Optic Transmitter

K:\04_1701_ITS\011056158-US 52 ITS (U-2826B)\Plan Set 0026.dgn 1:30:55 PM susan.pennell@ncdot.gov 1/25/2011

PLANS PREPARED IN THE OFFICE OF:

 Kimley-Horn and Associates, Inc.
 P.O. Box 33068
 Raleigh N.C. 27636-3068
 (919) 677-2000
 N.C. License # F-002

 259 N. Greenfield Place, Garner, NC 27529	U-2826B DIVISION 9 OFFICE		SEAL STEPHANIE B. PRIVETTE
	DIVISION 9 FORSYTH COUNTY WINSTON SALEM		
	PLAN DATE: JANUARY 2011 PREPARED BY: J. Cross	REVIEWED BY: S. Privette	
SCALE 0	REVISIONS INIT. DATE	SIGNATURE DATE: 1.25.11	CADD Filename

INSTALL NEW ETHERNET ROUTING SWITCH AND CABLING INTO EXISTING RACK CABINET. CONNECT NEW SWITCH TO FIBER INTERCONNECT CENTER AND LAN SWITCH.

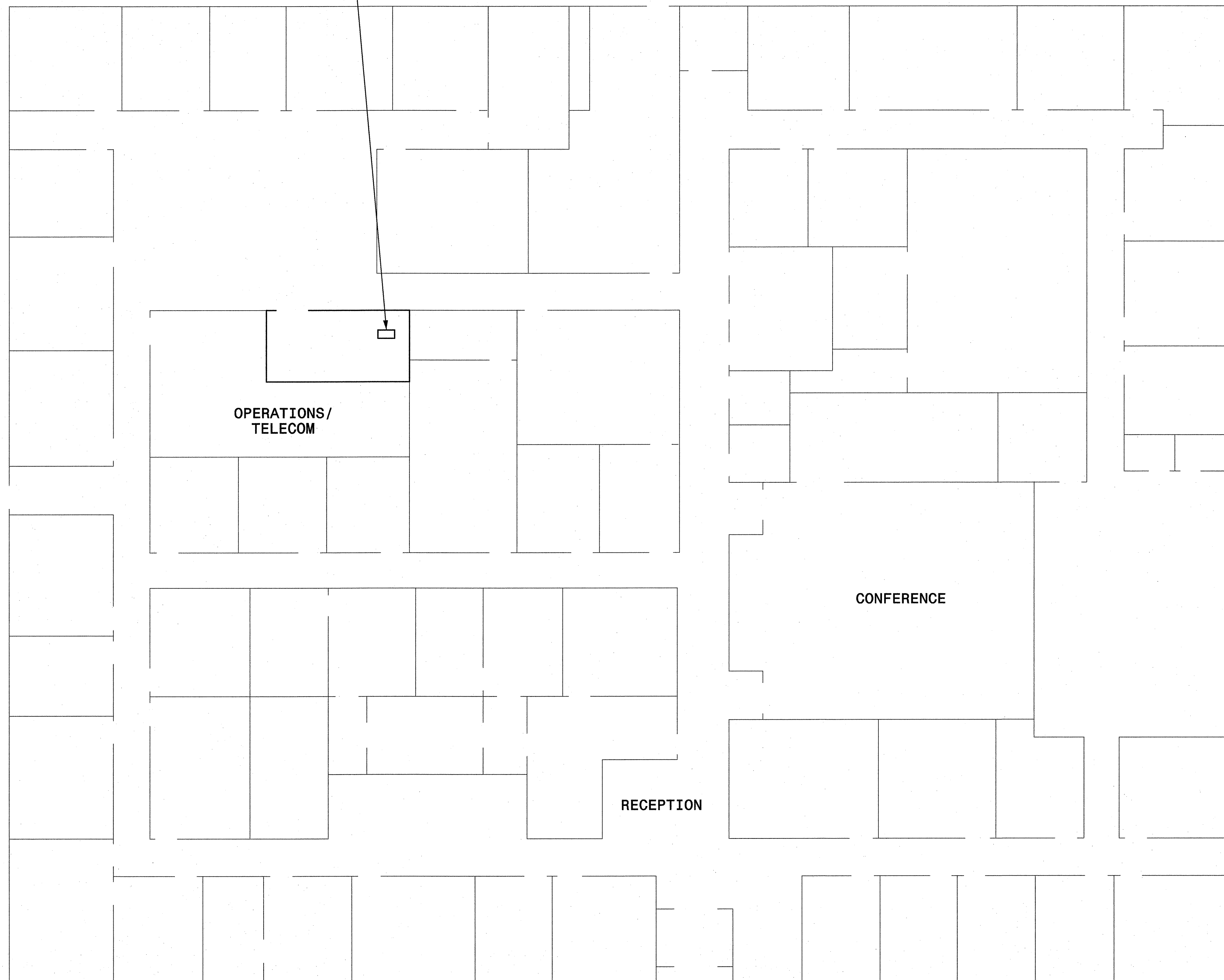

FRONT OF BUILDING

k:\rd\trn_its\0106188-us 52_its (u-2826b)\plan\st 020c.dgn
11:45:55 AM
jerry.cross
1/25/2011

PLANS PREPARED IN THE OFFICE OF:

Kimley-Horn and Associates, Inc.
P.O. Box 33068
Raleigh, N.C. 27636-3068
(919) 677-2000
N.C. License # F-0102

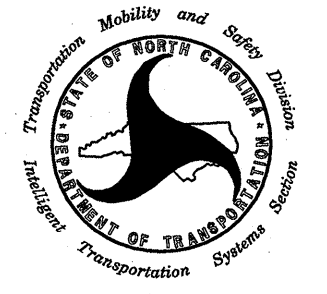

750 N. Greenfield Pkwy., Garner, NC 27529

SCALE
0

U-2826B			
DIVISION 9 OFFICE			
DIVISION 9 FORSYTH COUNTY WINSTON SALEM			
PLAN DATE: JANUARY 2011	REVIEWED BY:		
PREPARED BY: J. Cross	REVIEWED BY: S. Privette		
REVISIONS	INIT.	DATE	

SEAL

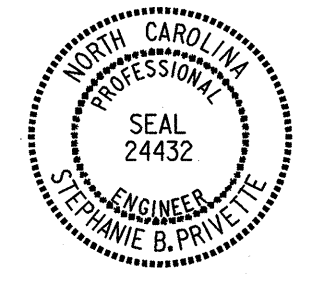

STEPHANIE B. PRIVETTE
SEAL 24432

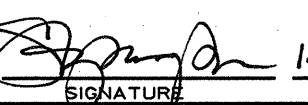
 1/25/11
SIGNATURE DATE

CADD Filename:

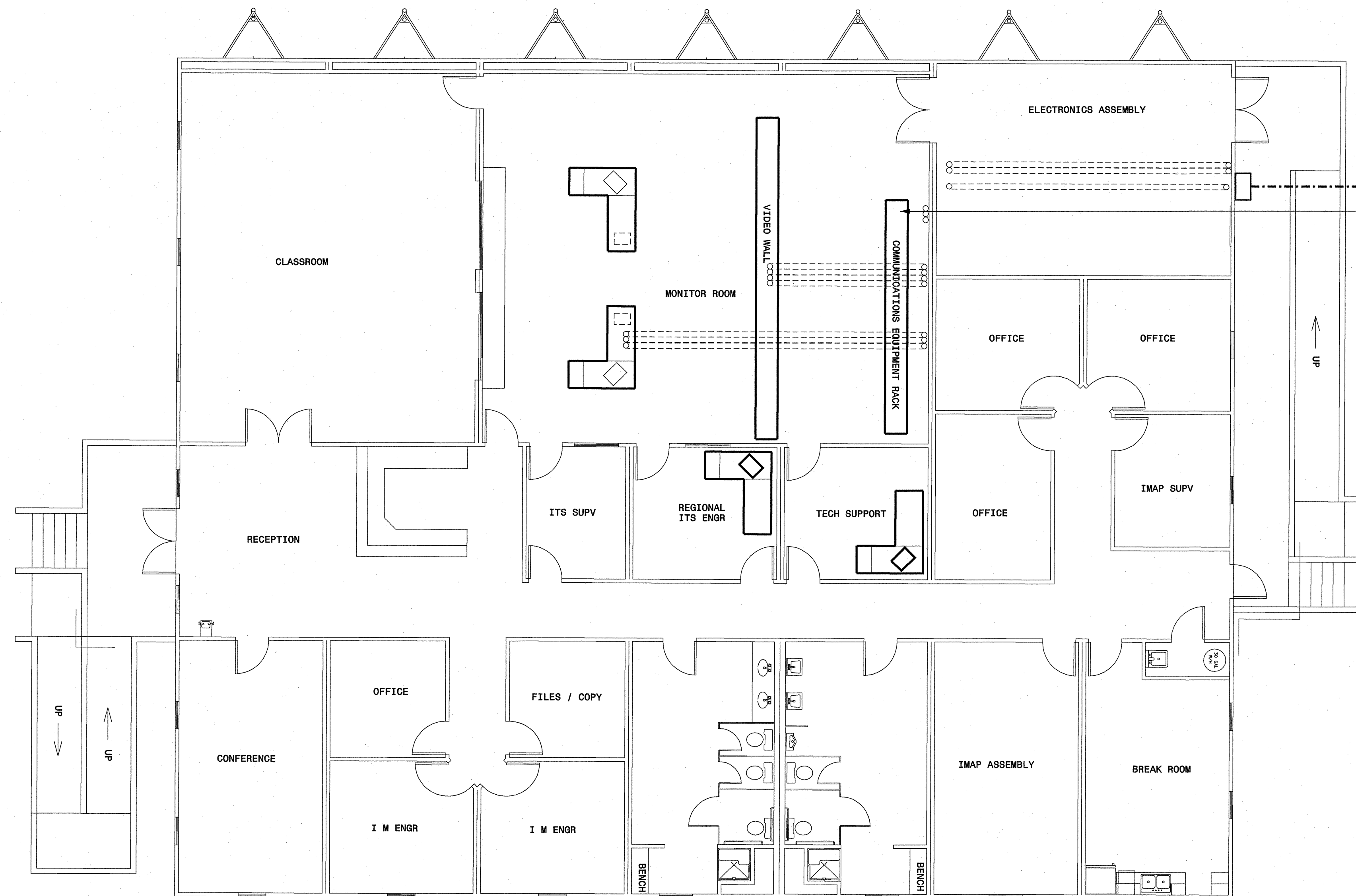

INSTALL NEW 19" EQUIPMENT RACK WITH CABLE MANAGEMENT SYSTEM. INSTALL ETHERNET CORE SWITCH, VIDEO DECODERS, AND CABLING. CONNECT TO EXISTING EQUIPMENT AS SHOWN ON THE BLOCK DIAGRAM

1/25/2011 11:46:36 AM jerry.cross k:\val_tproj_its\01086188-us 52_its (u-2826b)\plan\shd 020a.dgn

PLANS PREPARED IN THE OFFICE OF:

Kimley-Horn and Associates, Inc.
 P.O. Box 33068
 Raleigh N.C. 27636-3068
 (919) 877-2000
 N.C. License # F-0102

750 N. Greenfield Pkwy., Garner, NC 27529

U-2826B			
TRIAD REGIONAL TRANSPORTATION MANAGEMENT CENTER			
DIVISION 9		FORSYTH COUNTY WINSTON SALEM	
PLAN DATE:	JANUARY 2011	REVIEWED BY:	
PREPARED BY:	J. Cross	REVIEWED BY:	S. Privette
REVISIONS	INIT.	DATE	

SEAL

STEPHANIE B. PRIVETTE
 ENGINEER
 SEAL 24432
 STATE OF NORTH CAROLINA

1/25/11
 SIGNATURE DATE
 CADD Filename:

DETAIL "A"

DETAIL "B"

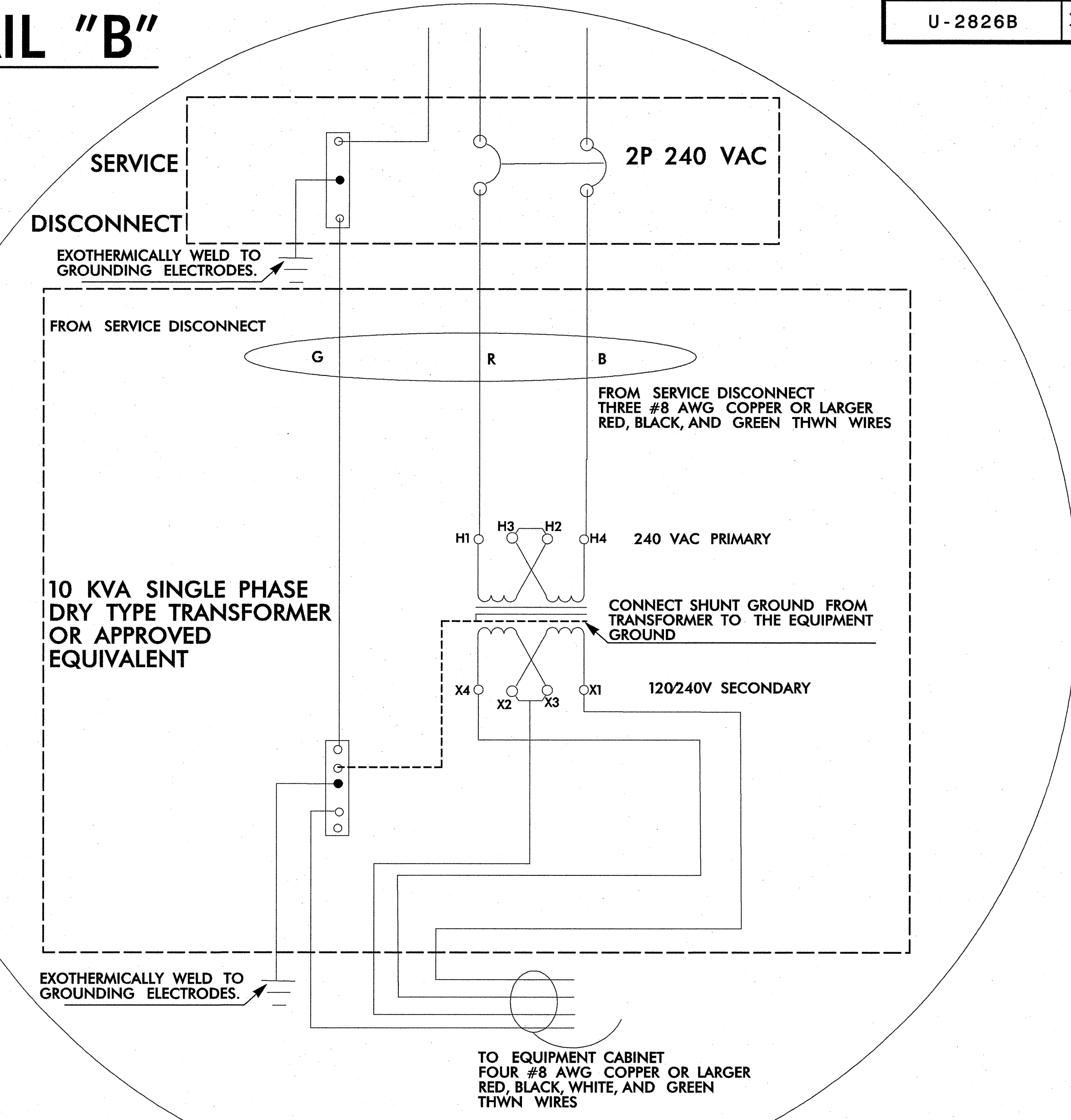
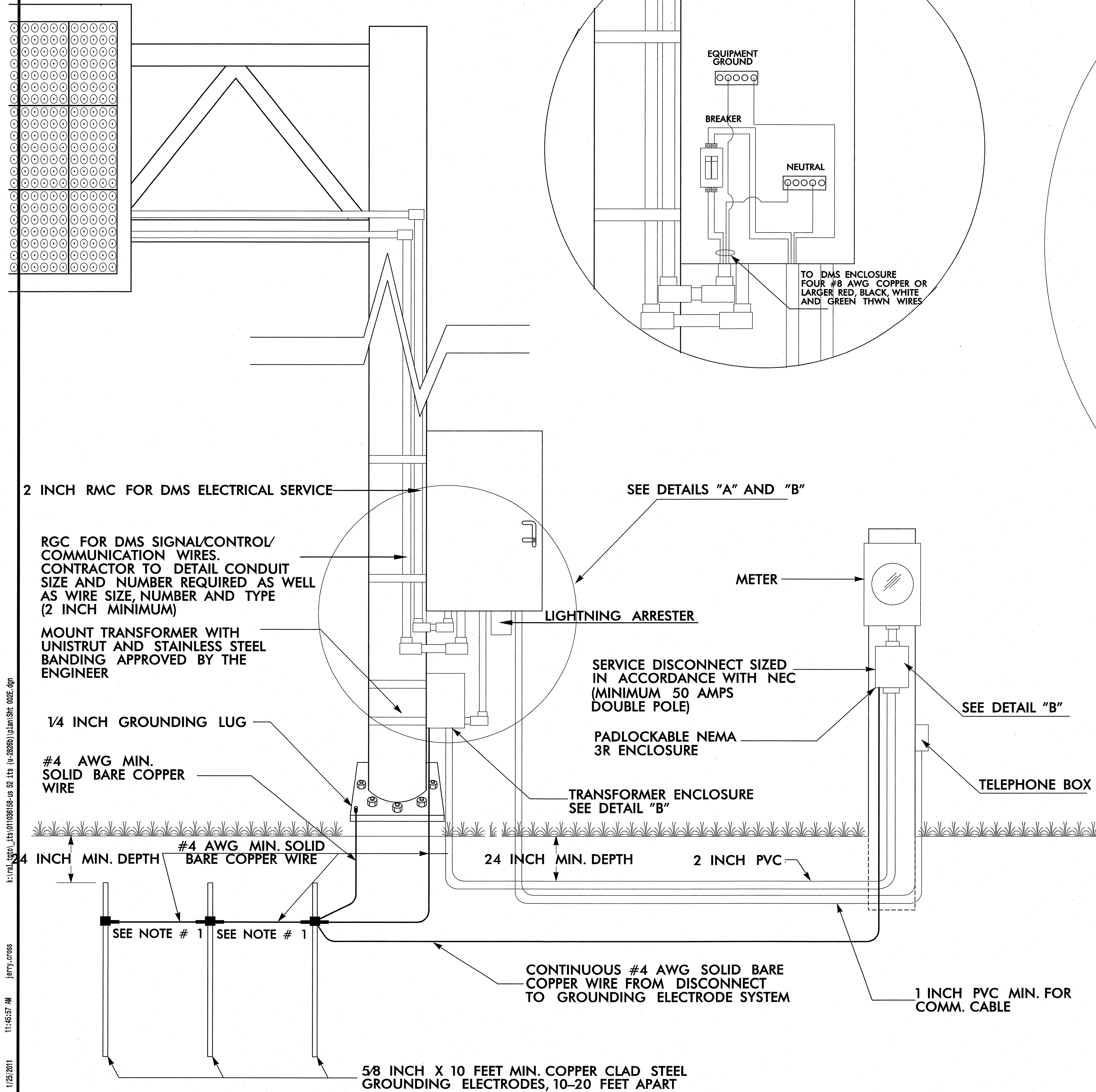

NOTES

1. INSTALL A MINIMUM OF THREE GROUND RODS SPACED A MINIMUM OF 10 FEET APART. ENSURE THAT EXISTING UNDERGROUND FACILITIES ARE NOT DAMAGED DURING INSTALLATION.
2. TEST GROUNDING SYSTEM USING AN APPROVED METHOD. SYSTEM SHALL MEASURE TWENTY (20) OHMS OR LESS. ADDITIONAL GROUND RODS SHALL BE INSTALLED AS DIRECTED BY THE ENGINEER TO MEET THIS REQUIREMENT.
3. EXOTHERMICALLY WELD ALL CONNECTIONS TO GROUND RODS.
4. INSTALL MARKER TAPE DIRECTLY ABOVE ALL GROUNDING ELECTRODES AND CONDUCTORS AT A DEPTH OF 12 INCHES.
5. EXOTHERMICALLY WELD THE SERVICE POLE GROUND WIRE TO THE GROUND ROD SYSTEM.
6. REMOVE BONDING JUMPER BETWEEN EQUIPMENT GROUND AND AC NEUTRAL IN THE EQUIPMENT CABINET.
7. BOND ALL RIGID GALVANIZED STEEL CONDUITS ENTERING THE CABINET TO EQUIPMENT GROUND.
8. ALL ABOVE GROUND CONDUITS SHALL BE RGC OR LIQUIDTIGHT FLEXIBLE METAL CONDUIT (LFMC). PVC CONDUITS ARE ALLOWED FOR UNDERGROUND INSTALLATIONS.
9. SERVICE DISCONNECT NEUTRAL BUS BAR SHALL PROVIDE FOR 2 #4 AWG CONNECTIONS.
10. ENSURE EQUIPMENT GROUND IS ELECTRICALLY BONDED TO EQUIPMENT CABINET.
11. ENSURE TELEPHONE SERVICE IN THE EQUIPMENT CABINET IS BONDED TO EQUIPMENT GROUND.

PLANS PREPARED IN THE OFFICE OF:

Kimley-Horn and Associates, Inc.
 P.O. Box 33068
 Raleigh, N.C. 27636-3068
 (919) 677-2000
 N.C. License # F-002

 STATE OF NORTH CAROLINA PROFESSIONAL ENGINEER SEAL 24432 STEPHANIE B. PRIVETTE	U-2826B DYNAMIC MESSAGE SIGN ELECTRICAL SERVICE WITH ISOLATION TRANSFORMER		SEAL 24432 DATE 1-25-11
	DIVISION 9 FORSYTH COUNTY WINSTON SALEM PLAN DATE: JANUARY 2011 REVIEWED BY: PREPARED BY: J. Cross REVIEWED BY: S. Privette		
SCALE 		REVISIONS INIT. DATE	

1/25/2011 11:45:57 AM jerry.cross
 k:\na\proj_its\01038158-us_52_1ts (U-2826B)\plan\shd 002E.dgn

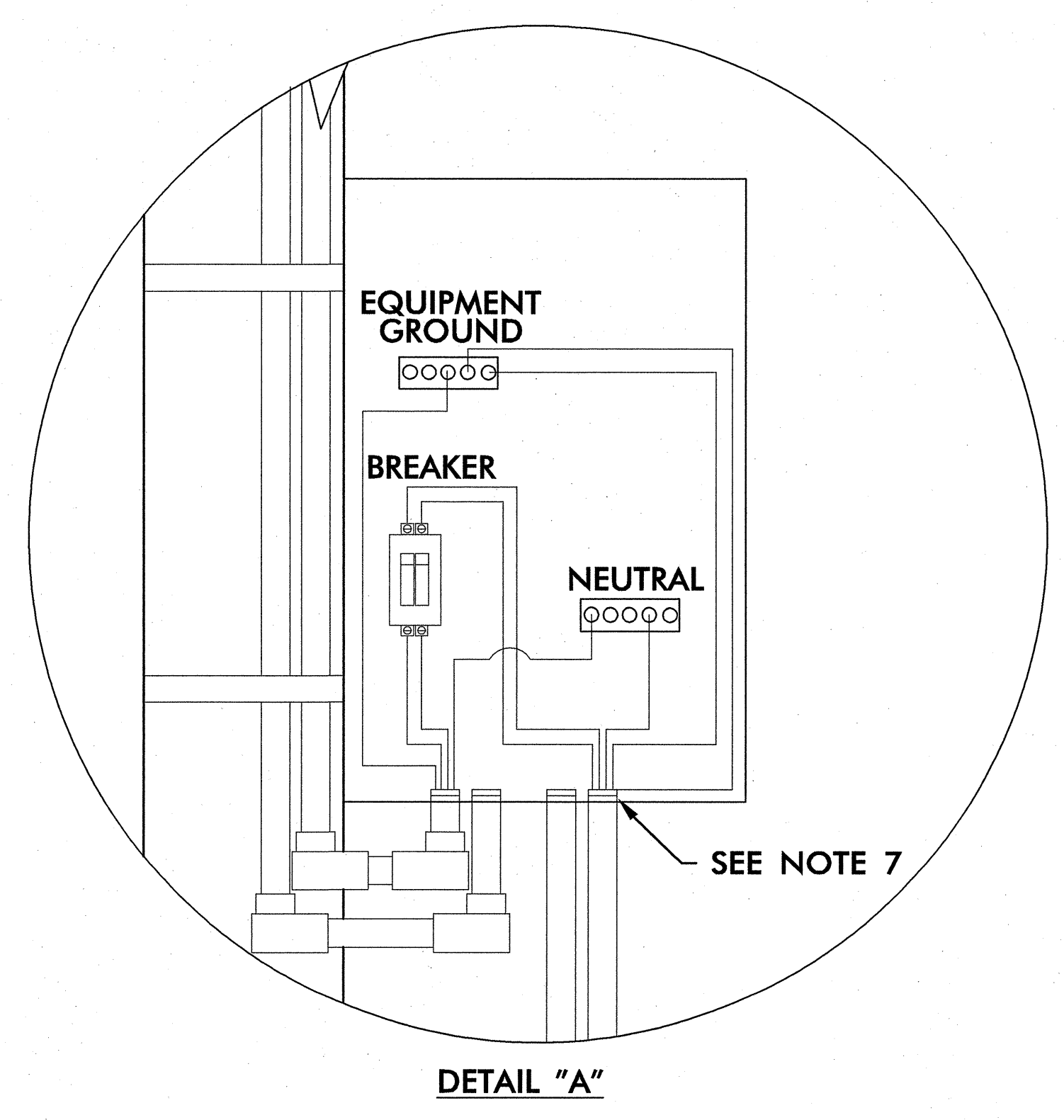
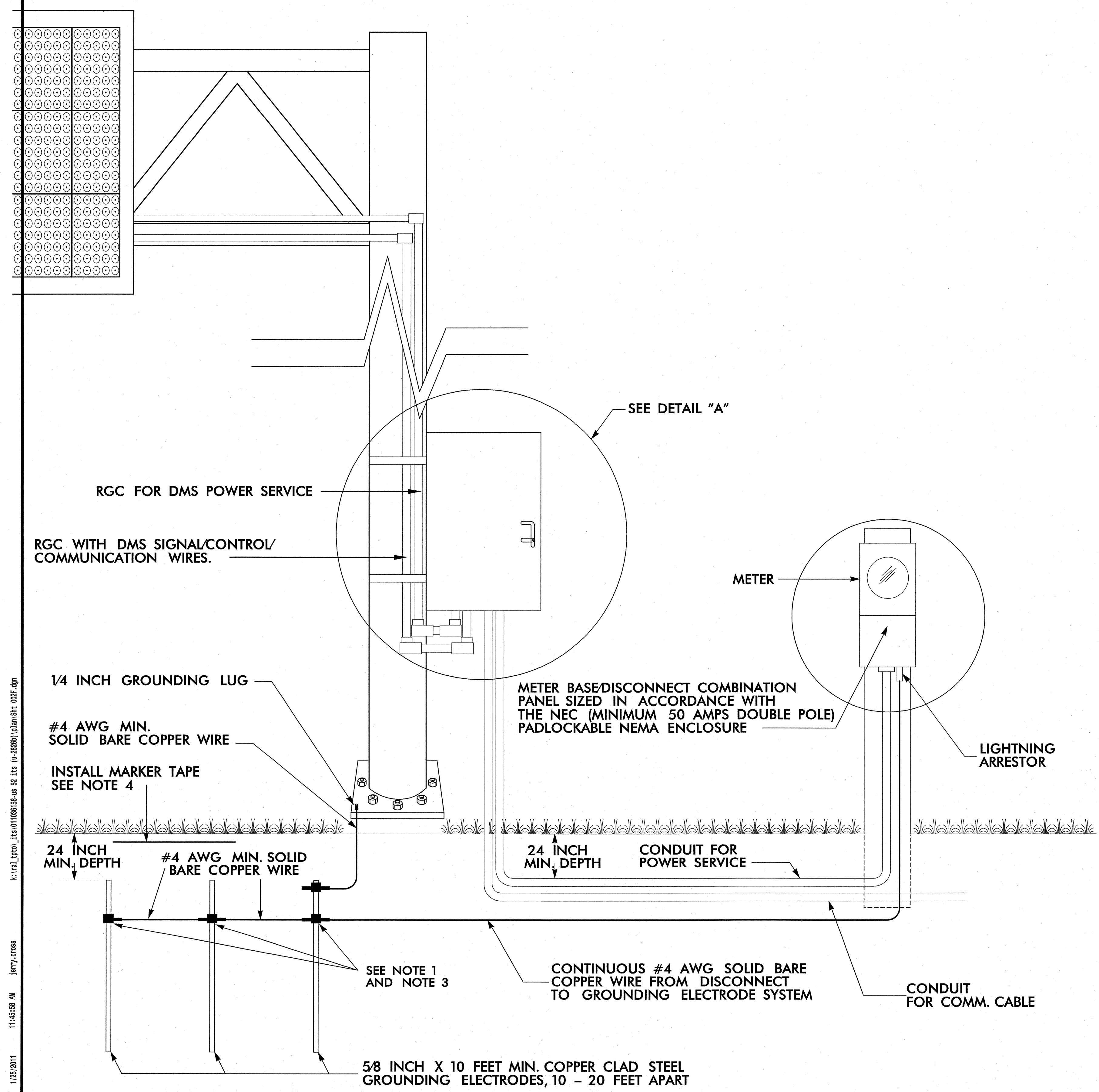

NOTES

1. INSTALL A MINIMUM OF THREE (3) GROUND RODS SPACED A MINIMUM OF 10 FEET APART. ENSURE THAT EXISTING UNDERGROUND FACILITIES ARE NOT DAMAGED DURING INSTALLATION.
2. TEST GROUNDING SYSTEM USING AN APPROVED METHOD. SYSTEM SHOULD MEASURE TWENTY (20) OHMS OR LESS. ADDITIONAL GROUND RODS SHALL BE INSTALLED AS DIRECTED BY THE ENGINEER TO MEET THIS REQUIREMENT.
3. EXOTHERMICALLY WELD ALL CONNECTIONS TO GROUND RODS.
4. INSTALL MARKER TAPE DIRECTLY ABOVE ALL GROUNDING ELECTRODES AND CONDUCTORS AT A DEPTH OF 6 - 12 INCHES.
5. EXOTHERMICALLY WELD THE SERVICE POLE GROUND WIRE TO THE GROUND ROD SYSTEM.
6. REMOVE BONDING JUMPER IN EQUIPMENT CABINET IF INSTALLED BETWEEN AC NEUTRAL AND EQUIPMENT GROUND.
7. BOND ALL RIGID GALVANIZED STEEL CONDUITS ENTERING THE CABINET TO "EQUIPMENT GROUND".
8. INSTALL CONDUIT BETWEEN DISCONNECT AND CABINET.
9. SERVICE DISCONNECT NEUTRAL BUS BAR SHALL PROVIDE FOR 2 #4 AWG CONNECTIONS.
10. ENSURE EQUIPMENT GROUND IS ELECTRICALLY BONDED TO CABINET.

k:\n\proj\tsa\011086158-us 52.tss (U-2826B)\plan\shd_0025.dgn
 11:46:58 AM jerry.cross
 1/25/2011

PLANS PREPARED IN THE OFFICE OF:

Kimley-Horn and Associates, Inc.
 P.O. Box 33068
 Raleigh N.C. 27636-3068
 (919) 677-2000
 N.C. License # F-0102

	U-2826B DYNAMIC MESSAGE SIGN ELECTRICAL SERVICE AND GROUNDING TYPICAL DETAIL		SEAL NORTH CAROLINA PROFESSIONAL ENGINEER SEAL 24432 STEPHANIE B. PRIVETTE
	DIVISION 9 FORSYTH COUNTY WINSTON SALEM		
PLAN DATE: JANUARY 2011	REVIEWED BY:		
PREPARED BY: J. Cross	REVIEWED BY: S. Privette		
REVISIONS	INIT.	DATE	
0			
SCALE			1/25-11 DATE
CADD Filename:			

INSET 'A'

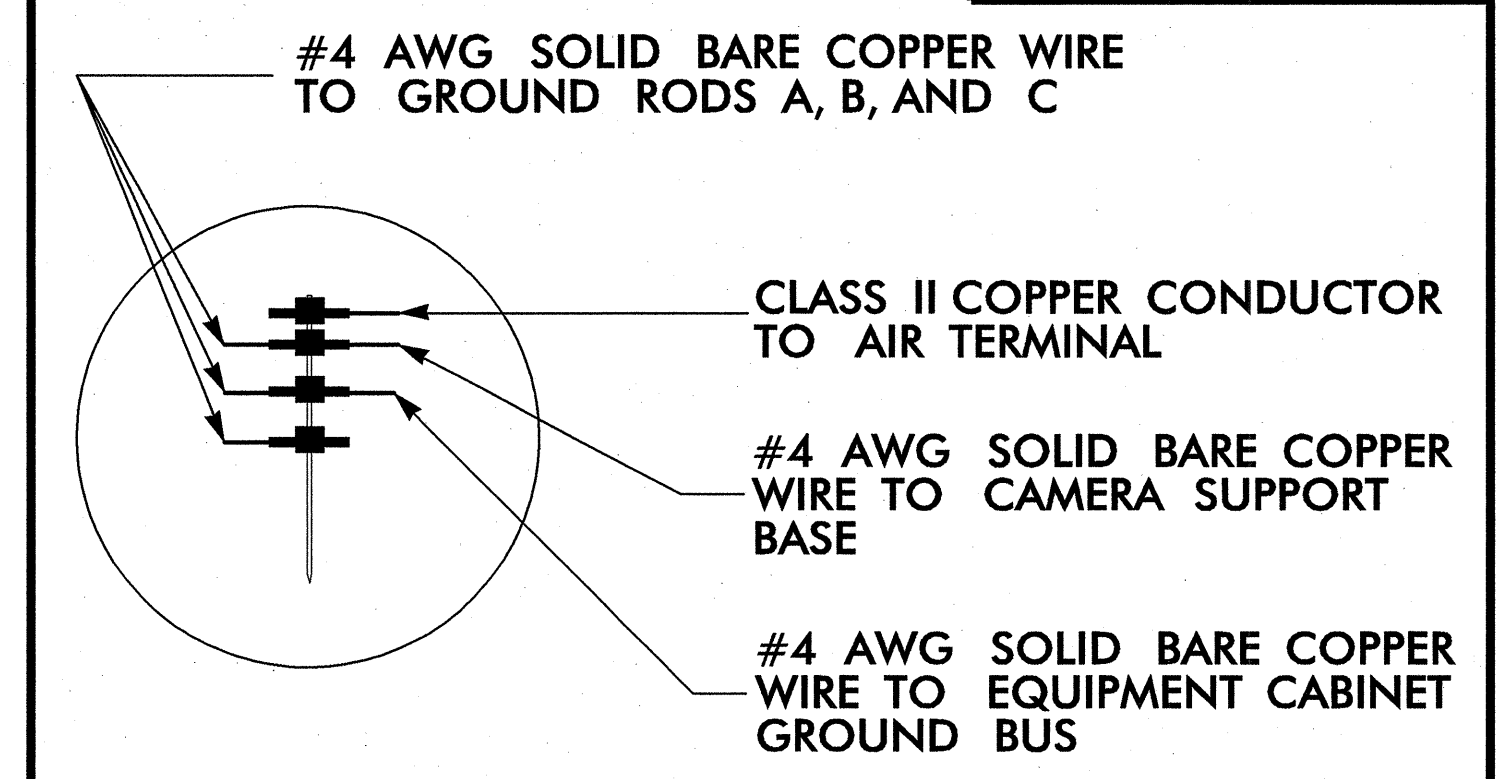

10 FOOT RADIUS EACH "SPHERE OF INFLUENCE"

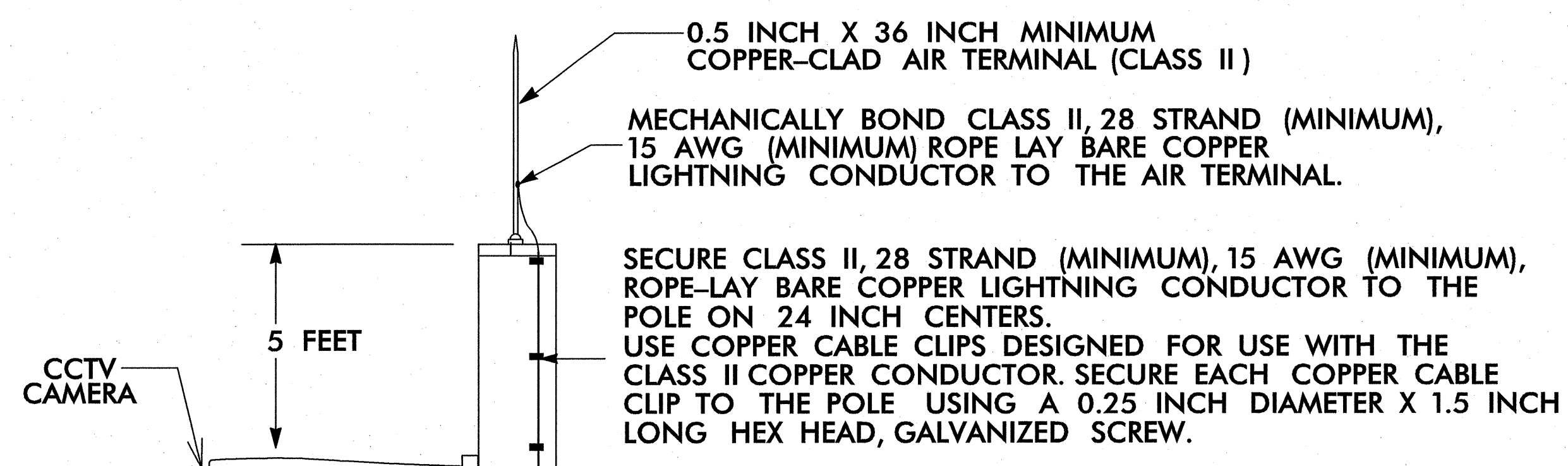
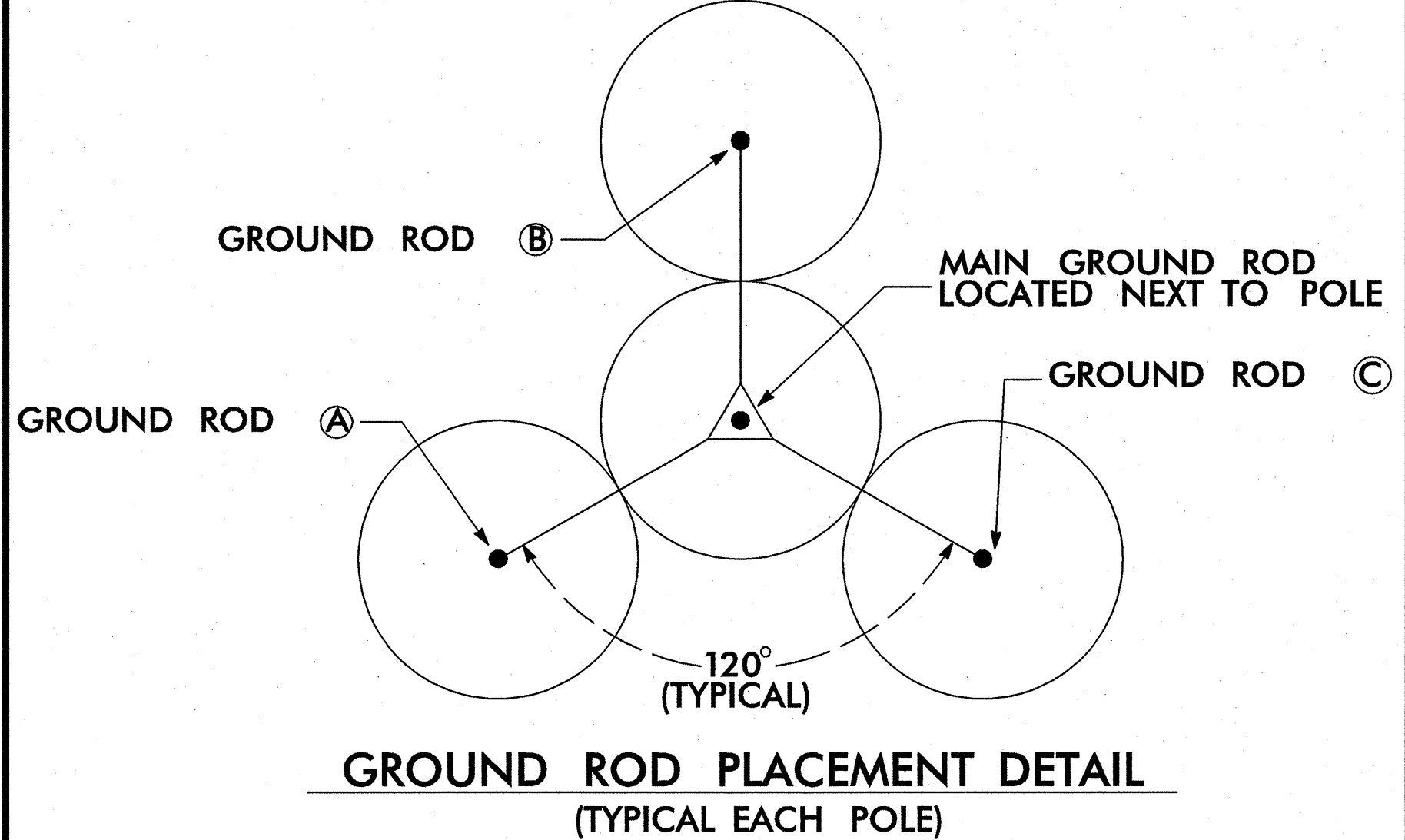

BOND #4 AWG SOLID BARE COPPER WIRE TO CAMERA SUPPORT BASE BY AN ALUMINUM TO COPPER #2 - #14 AWG LUG. ATTACH TO CAMERA BASE WITH A STAINLESS STEEL SELF TAPPING SCREW. REMOVE PAINT OR PROTECTIVE COATING WHERE ATTACHING LUG ONLY.

INSTALL 2-INCH PVC U-GUARD OVER COPPER CONDUCTOR FROM GROUND LEVEL TO 10 FEET (MINIMUM) ABOVE THE GROUND.

2-INCH RIGID GALVANIZED STEEL RISER FOR POWER AND CONTROL WIRES

1-INCH RIGID GALVANIZED STEEL RISER WITH WEATHERHEAD

POLE MOUNT EQUIPMENT CABINET

METER BASE / DISCONNECT COMBINATION PANEL

SEE NOTE 5

1-INCH CONDUIT FOR FEEDER

ALTERNATE GROUNDING METHOD

IF SPACE IS NOT AVAILABLE TO DRIVE MULTIPLE RODS, DRIVE SECTIONAL GROUND RODS A MINIMUM OF 30 FEET.

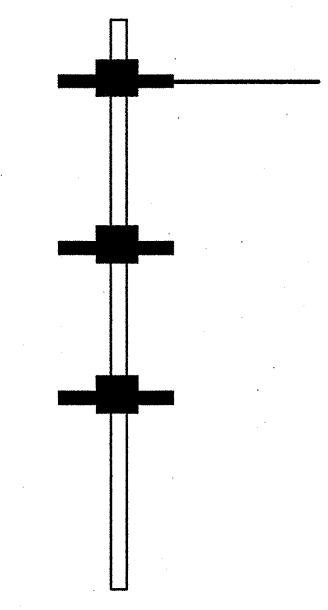

JOIN SECTIONAL GROUND RODS BY EXOTHERMIC WELDING CONNECTION

INSTALL ELECTRICAL SERVICE POLE NEAR RIGHT OF WAY OR AS DIRECTED BY THE ENGINEER.

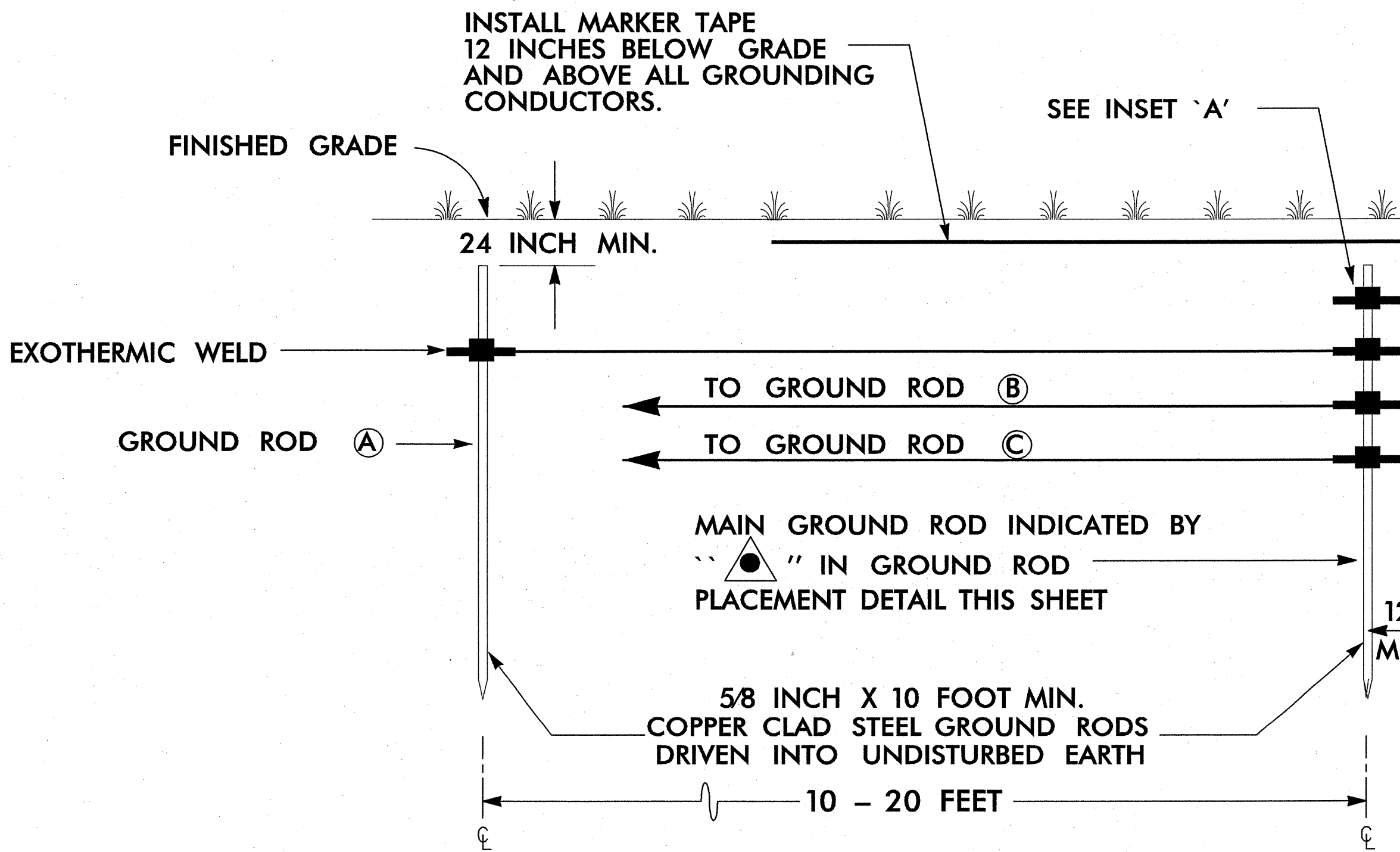

NOTES

- BOND CLASS II, 28 STRAND (MINIMUM), 15 AWG (MINIMUM) ROPE-LAY BARE COPPER CONDUCTOR TO THE MAIN GROUND ROD BY AN EXOTHERMIC WELD METHOD. MAINTAIN MAXIMUM HORIZONTAL SEPARATION BETWEEN COPPER CONDUCTOR AND RISER.
- EXOTHERMICALLY WELD ALL CONNECTIONS TO GROUND RODS.
- THE CONTRACTOR MAY, UPON APPROVAL OF THE ENGINEER, INSTALL A 30-FOOT SECTIONAL GROUND ROD FOR INSTANCES WHEN CONDITIONS WILL NOT ALLOW FOR THE INSTALLATION OF THE 3 - RADIAL GROUND RODS.
- INSTALL MARKER TAPE DIRECTLY ABOVE ALL GROUNDING ELECTRODES AND CONDUCTORS AT A DEPTH OF 12 INCHES.
- REMOVE BONDING JUMPER BETWEEN EQUIPMENT CABINET GROUND BUS AND NEUTRAL BUS.

	<p>U-2826B CCTV CAMERA INSTALLATION FOR WOOD POLES WITH AERIAL ELECTRICAL SERVICE TYPICAL DETAIL</p>		
	<p>DIVISION 9 FORSYTH COUNTY WINSTON SALEM</p>	<p>PREPARED BY: J. Cross REVIEWED BY: S. Privette</p>	
<p>750 N. Greenfield Pkwy., Garner, NC 27529</p>	<p>PLAN DATE: JANUARY 2011</p>	<p>REVISIONS</p>	<p>INIT. DATE</p>
<p>SCALE 0</p>	<p>1/25/11</p>	<p>DATE</p>	<p>CADD Filename</p>

PLANS PREPARED IN THE OFFICE OF:
Kimley-Horn and Associates, Inc.
P.O. Box 33068
Raleigh, N.C. 27636-3068
(919) 677-2000
N.C. License # F-002

k:\real_proj_its\01086158-us_52_its (u-2826B)\plan\shd_0003.dgn
 11-46359 AW
 jbrty, cross
 1/25/2011

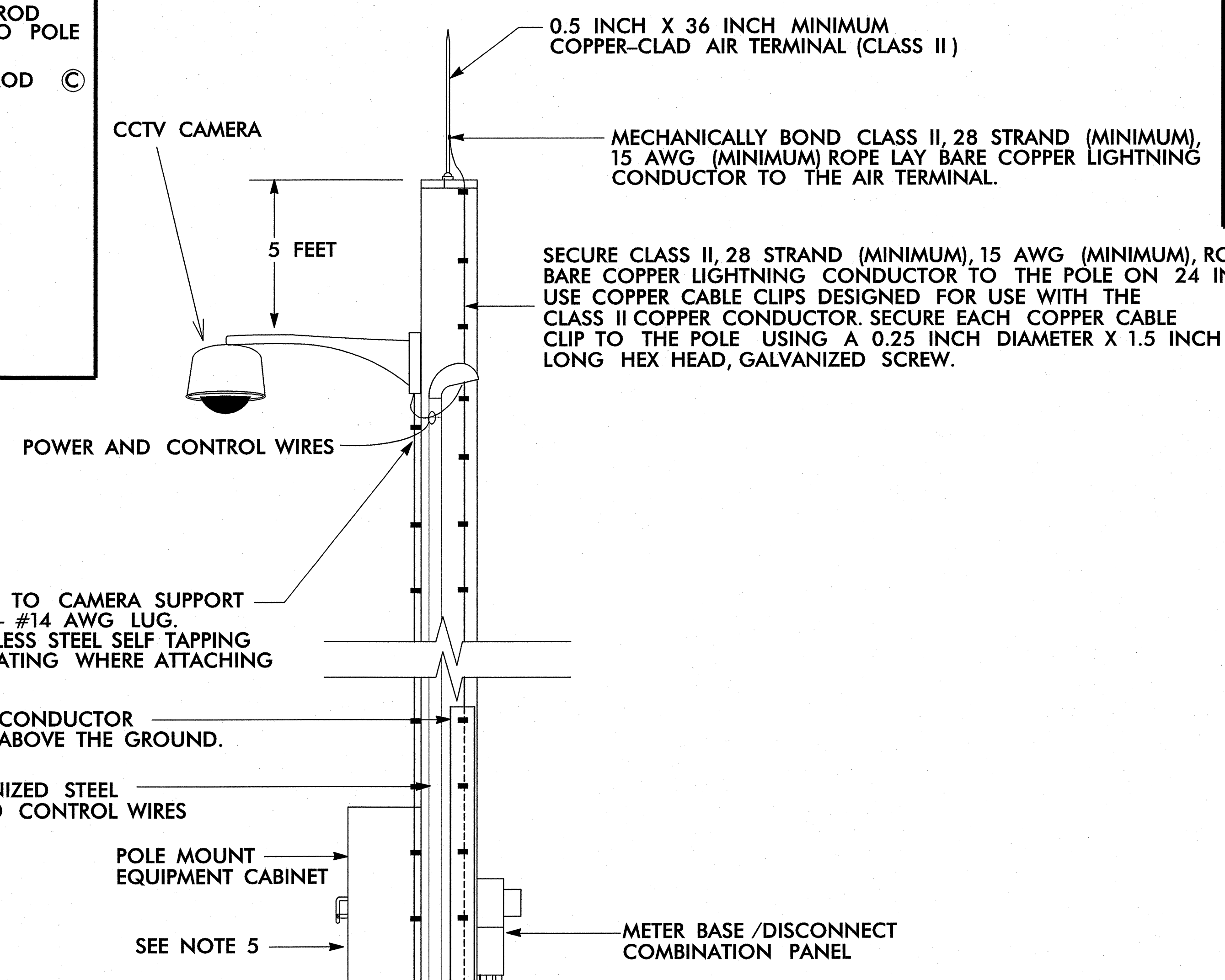
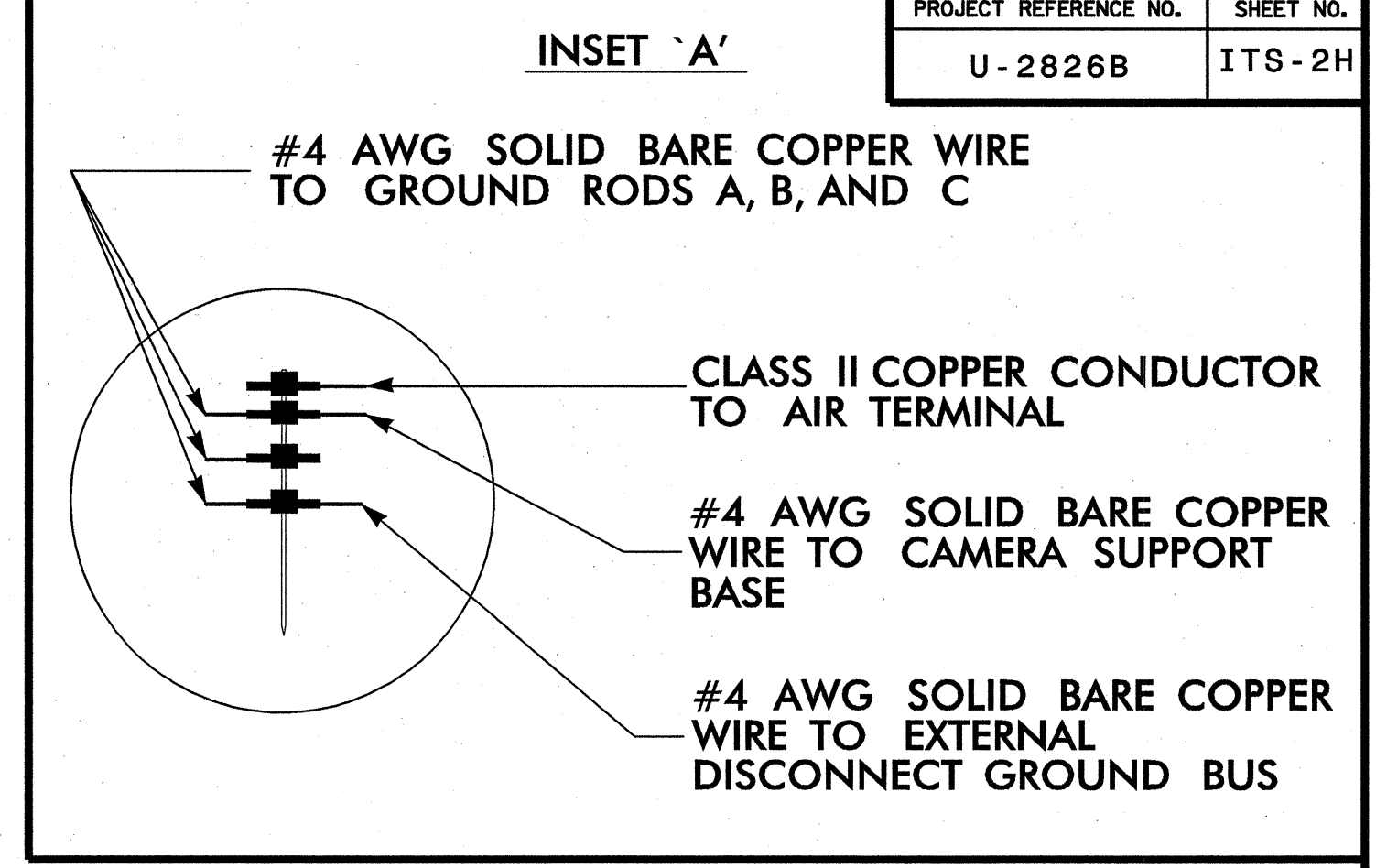
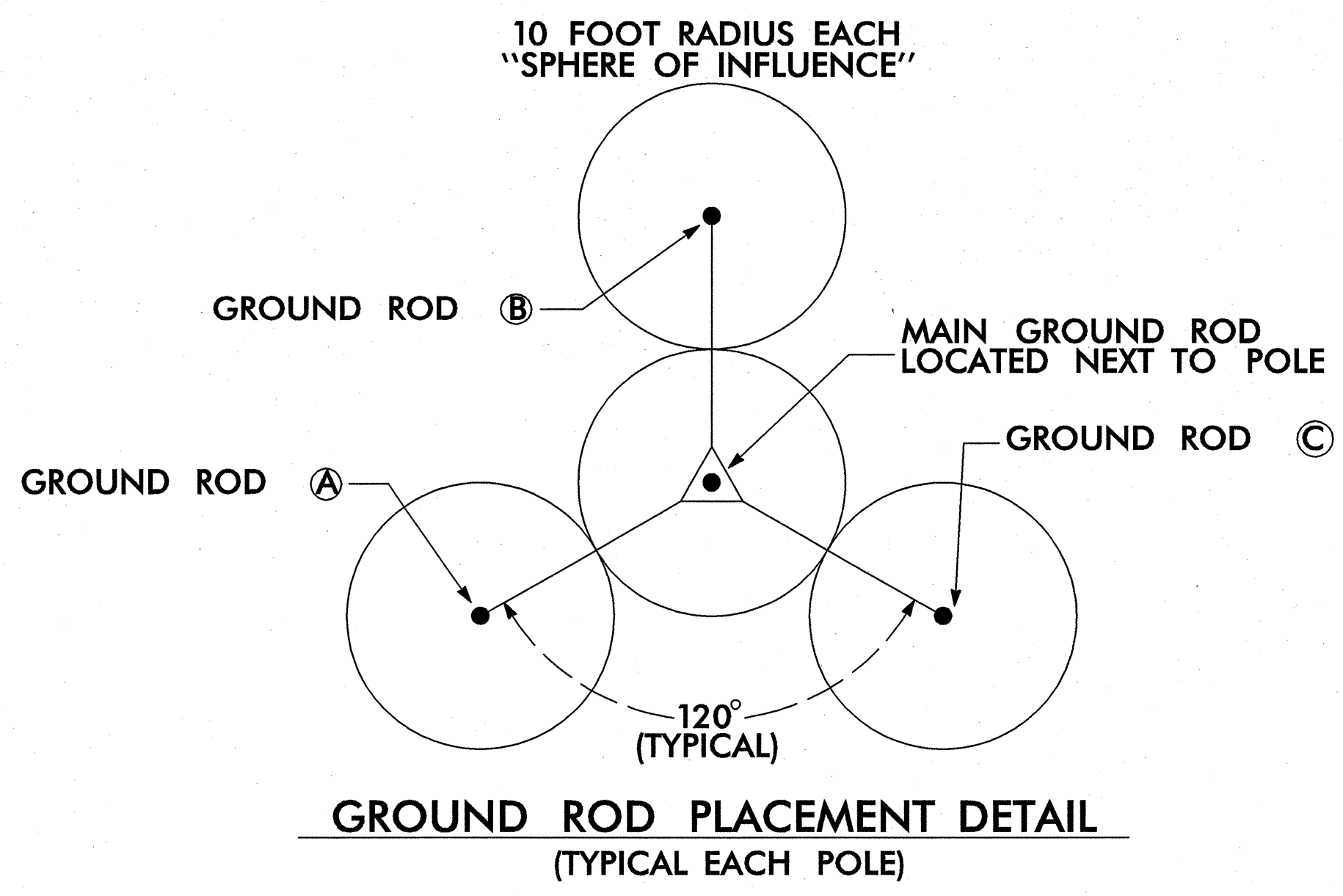

BOND #4 AWG SOLID BARE COPPER WIRE TO CAMERA SUPPORT BASE BY AN ALUMINUM TO COPPER #2 - #14 AWG LUG. ATTACH TO CAMERA BASE WITH A STAINLESS STEEL SELF TAPPING SCREW. REMOVE PAINT OR PROTECTIVE COATING WHERE ATTACHING LUG ONLY.

INSTALL 2-INCH PVC U-GUARD OVER COPPER CONDUCTOR FROM GROUND LEVEL TO 10 FEET (MINIMUM) ABOVE THE GROUND.

INSTALL MARKER TAPE 12 INCHES BELOW GRADE AND ABOVE ALL GROUNDING CONDUCTORS.

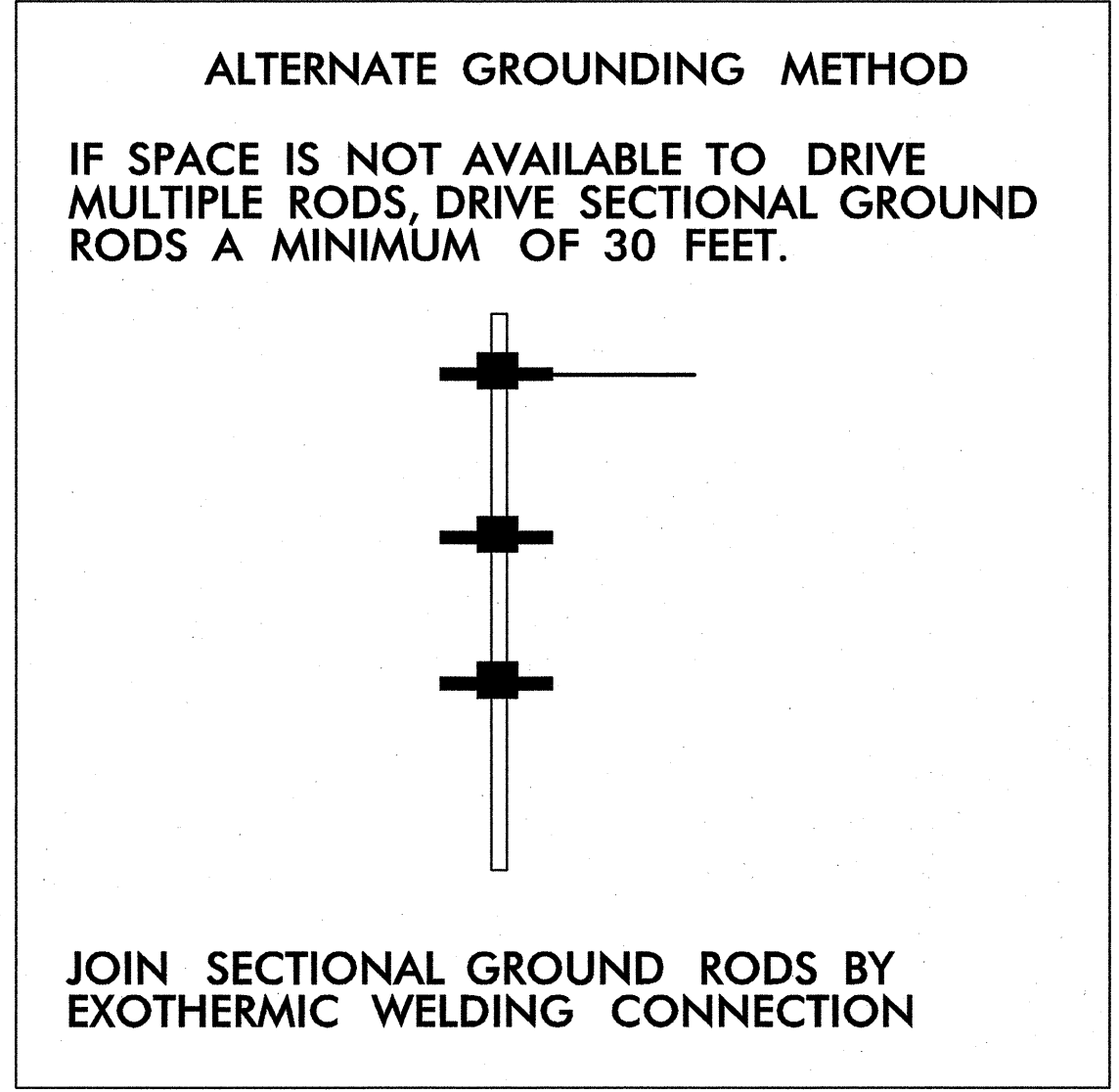

NOTES

1. BOND CLASS II, 28 STRAND (MINIMUM), 15 AWG (MINIMUM) ROPE-LAY BARE COPPER CONDUCTOR TO THE MAIN GROUND ROD BY AN EXOTHERMIC WELD METHOD. MAINTAIN MAXIMUM HORIZONTAL SEPARATION BETWEEN COPPER CONDUCTOR AND RISER.
2. EXOTHERMICALLY WELD ALL CONNECTIONS TO GROUND RODS.
3. THE CONTRACTOR MAY, UPON APPROVAL OF THE ENGINEER, INSTALL A 30-FOOT SECTIONAL GROUND ROD FOR INSTANCES WHEN CONDITIONS WILL NOT ALLOW FOR THE INSTALLATION OF THE 3 - RADIAL GROUND RODS.
4. INSTALL MARKER TAPE DIRECTLY ABOVE ALL GROUNDING ELECTRODES AND CONDUCTORS AT A DEPTH OF 12 INCHES.
5. REMOVE BONDING JUMPER BETWEEN EQUIPMENT CABINET GROUND BUS AND NEUTRAL BUS.

	U-2826B CCTV CAMERA INSTALLATION FOR WOOD POLES WITH UNDERGROUND ELECTRICAL SERVICE TYPICAL DETAIL		
	DIVISION 9 FORSYTH COUNTY WINSTON SALEM		
PLAN DATE: JANUARY 2011 PREPARED BY: J. Cross	REVIEWED BY: S. Privette	REVISIONS INIT. DATE	SIGNATURE: <i>Stephanie B. Privette</i> DATE: 1-25-11
SCALE: 0 NONE		SEAL: NONE	

PLANS PREPARED IN THE OFFICE OF:

Kimley-Horn and Associates, Inc.
 P.O. Box 33068
 Raleigh, N.C. 27636-3068
 (919) 677-2000
 N.C. License # F-002

1/25/2011 11:46:00 AM jerry.cross k:\val\proj\its\01088556-us_52_its (u-2826B)\plan\shd_002a.dgn

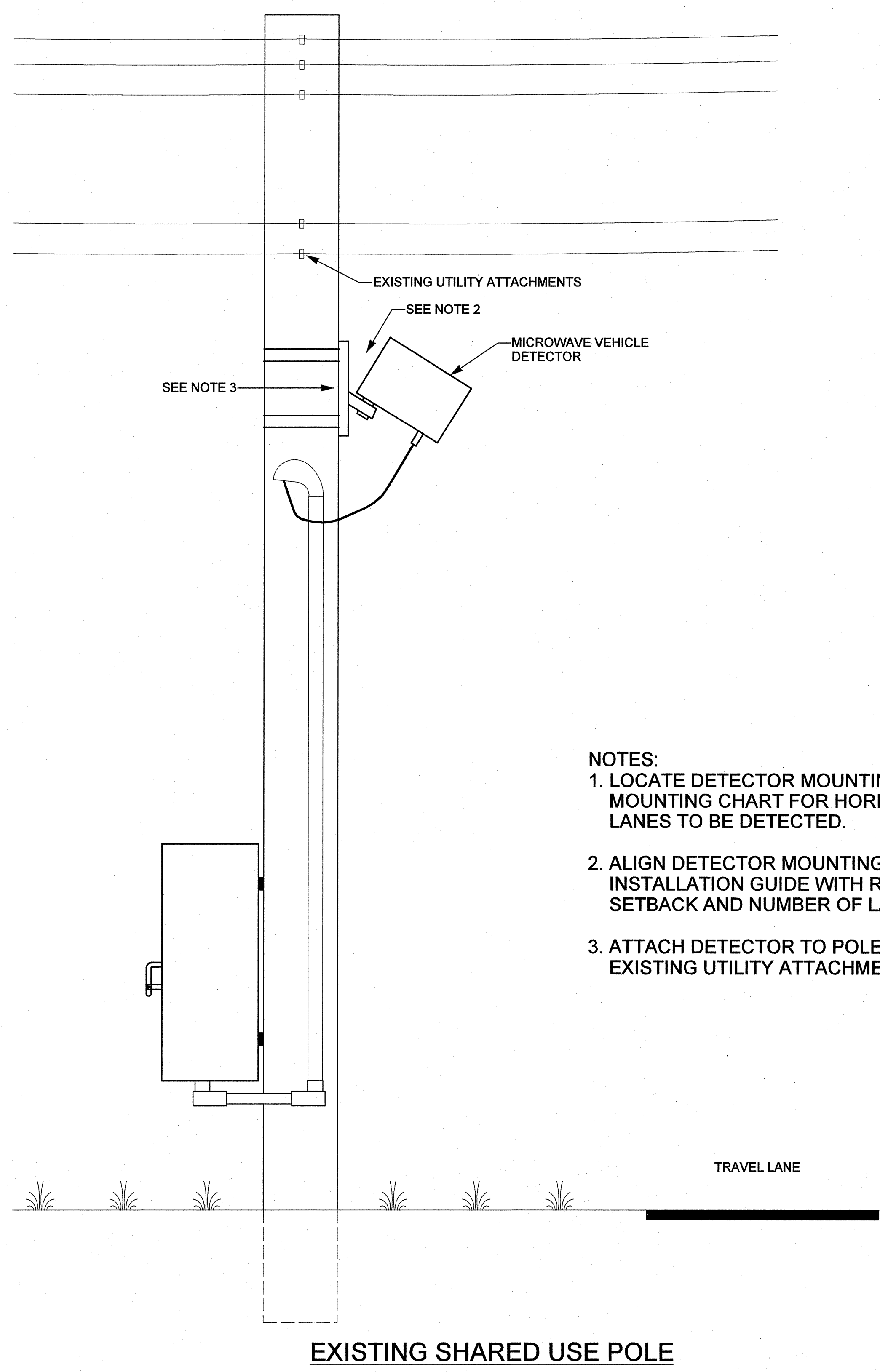
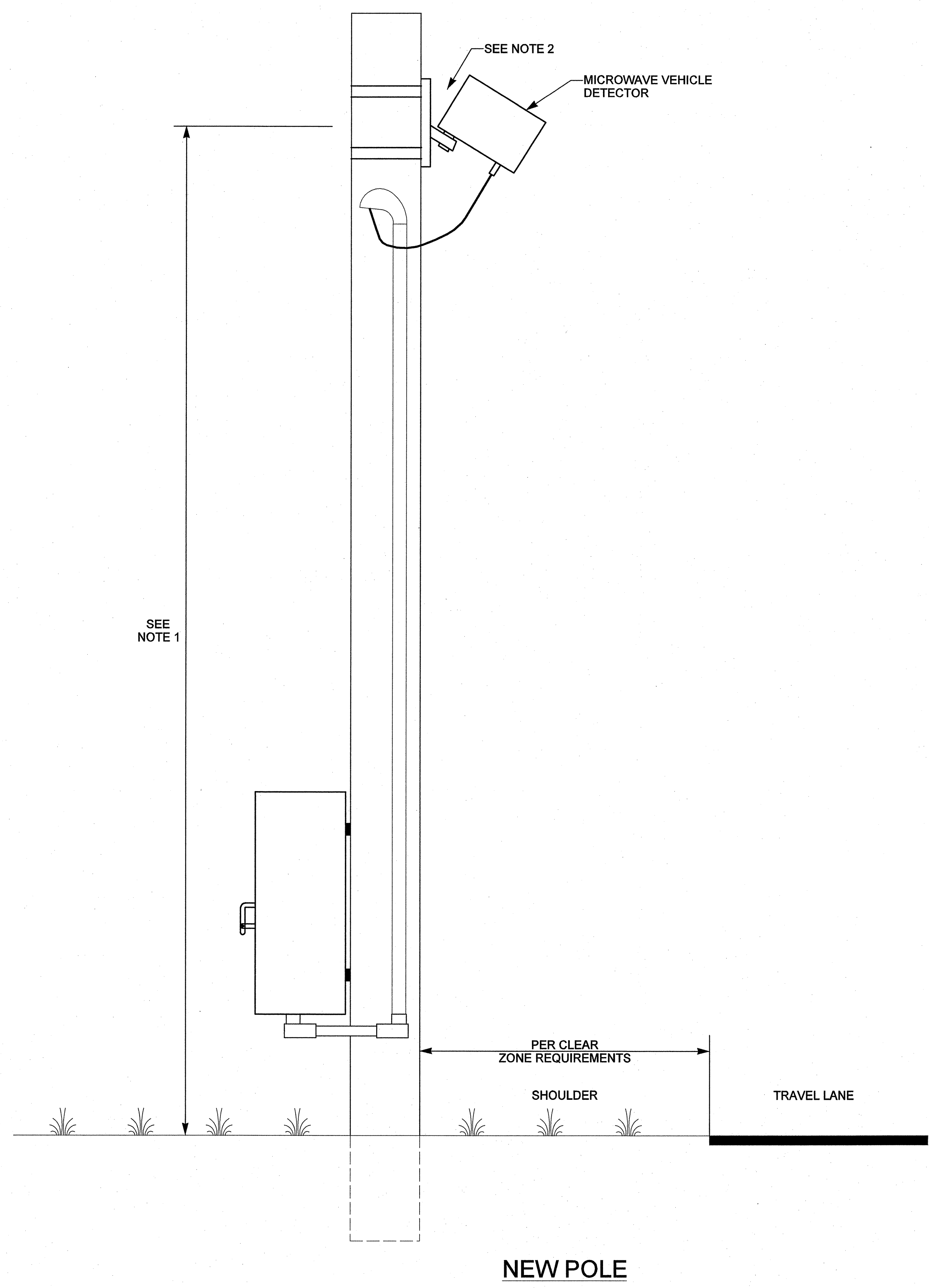

- NOTES:
1. LOCATE DETECTOR MOUNTING HEIGHT PER THE MANUFACTURER'S MOUNTING CHART FOR HORIZONTAL SETBACK AND NUMBER OF LANES TO BE DETECTED.
 2. ALIGN DETECTOR MOUNTING ANGLE PER THE MANUFACTURER'S INSTALLATION GUIDE WITH RESPECT TO HEIGHT, HORIZONTAL SETBACK AND NUMBER OF LANES DETECTED.
 3. ATTACH DETECTOR TO POLE IN NESC COMPLIANCE RELATIVE TO EXISTING UTILITY ATTACHMENTS.

k:\rad_tproj_its\01061618-us 52_its (u-2826b)\plan\shd 0102.dgn
 11:46:01 AM jerry.cross
 1/25/2011

PLANS PREPARED IN THE OFFICE OF:

Kimley-Horn and Associates, Inc.
 P.O. Box 33068
 Raleigh N.C. 27636-3068
 (919) 677-2000
 N.C. License # F-0102

	U-2826B		
	MICROWAVE VEHICLE DETECTION WOOD POLE MOUNTING		
DIVISION 9 FORSYTH COUNTY WINSTON SALEM		PREPARED BY: J. Cross REVIEWED BY: S. Privette	
PLAN DATE: JANUARY 2011	PREPARED BY: J. Cross	REVIEWED BY: S. Privette	SCALE: 0
REVISIONS	INIT.	DATE	SIGNATURE: <i>S. Privette</i> 1/25/11 DATE

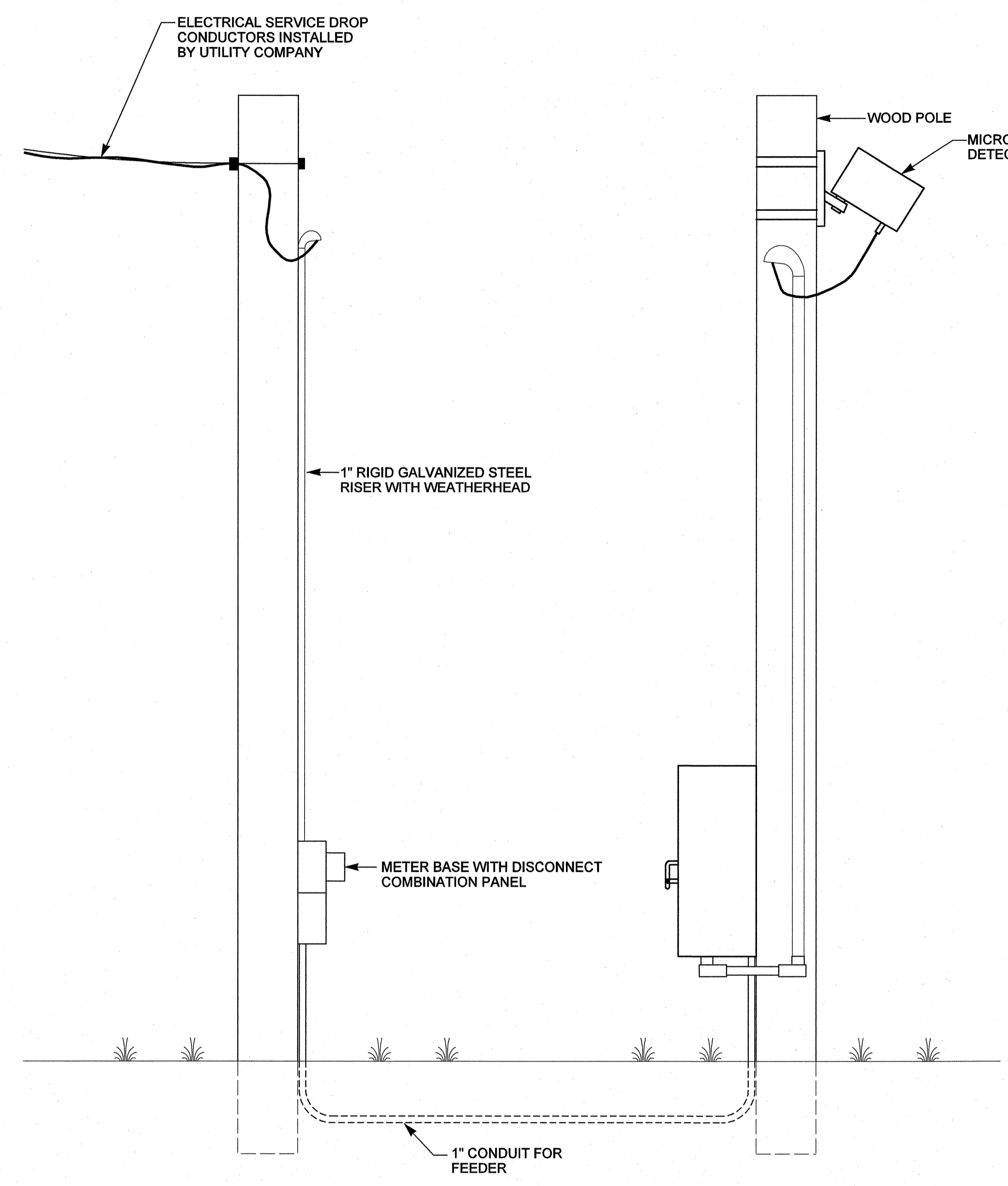

AERIAL ELECTRICAL SERVICE WITH SERVICE POLE

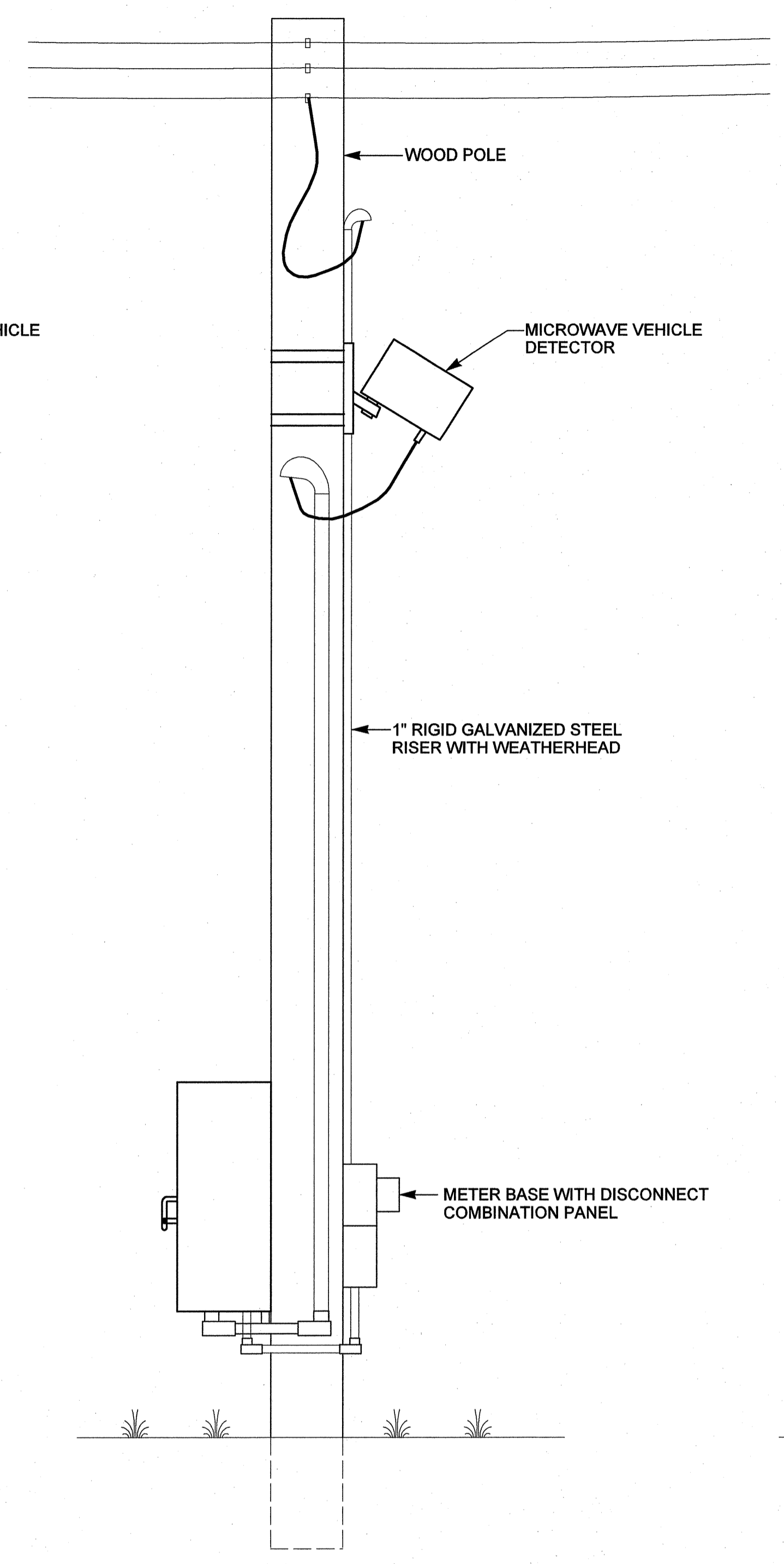

AERIAL ELECTRICAL SERVICE ON POLE

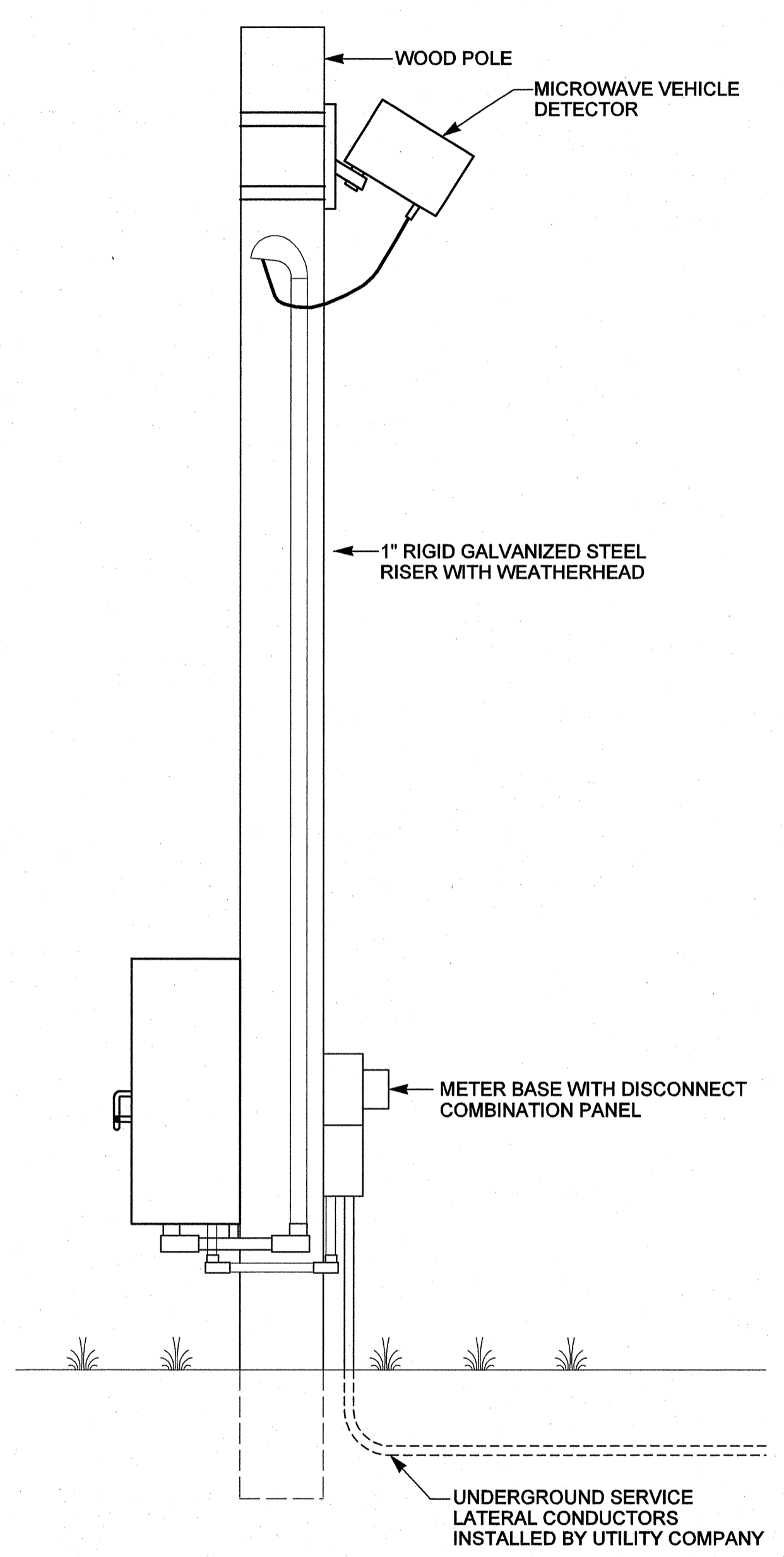

UNDERGROUND SERVICE

k:\val_tproj_its\1108158-us 2.its (U-2826B) (p.lam) (Sht. 002K.dgn) 1/25/2011 11:46:02 AM jerry.cross

PLANS PREPARED IN THE OFFICE OF:

Kimley-Horn and Associates, Inc.
 P.O. Box 33068
 Raleigh N.C. 27636-3068
 (919) 677-2000
 N.C. License # F-0102

 750 N. Greenfield Pkwy., Garner, NC 27529	U-2826B MICROWAVE VEHICLE DETECTION ELECTRICAL SERVICE		SEAL STEPHANIE B. PRIVETTE
	DIVISION 9 FORSYTH COUNTY WINSTON SALEM		
PLAN DATE: JANUARY 2011	REVIEWED BY:		DATE
PREPARED BY: J. Cross	REVIEWED BY: S. Privette		
SCALE 	REVISIONS	INIT.	DATE
SIGNATURE:			DATE: 1-25-11

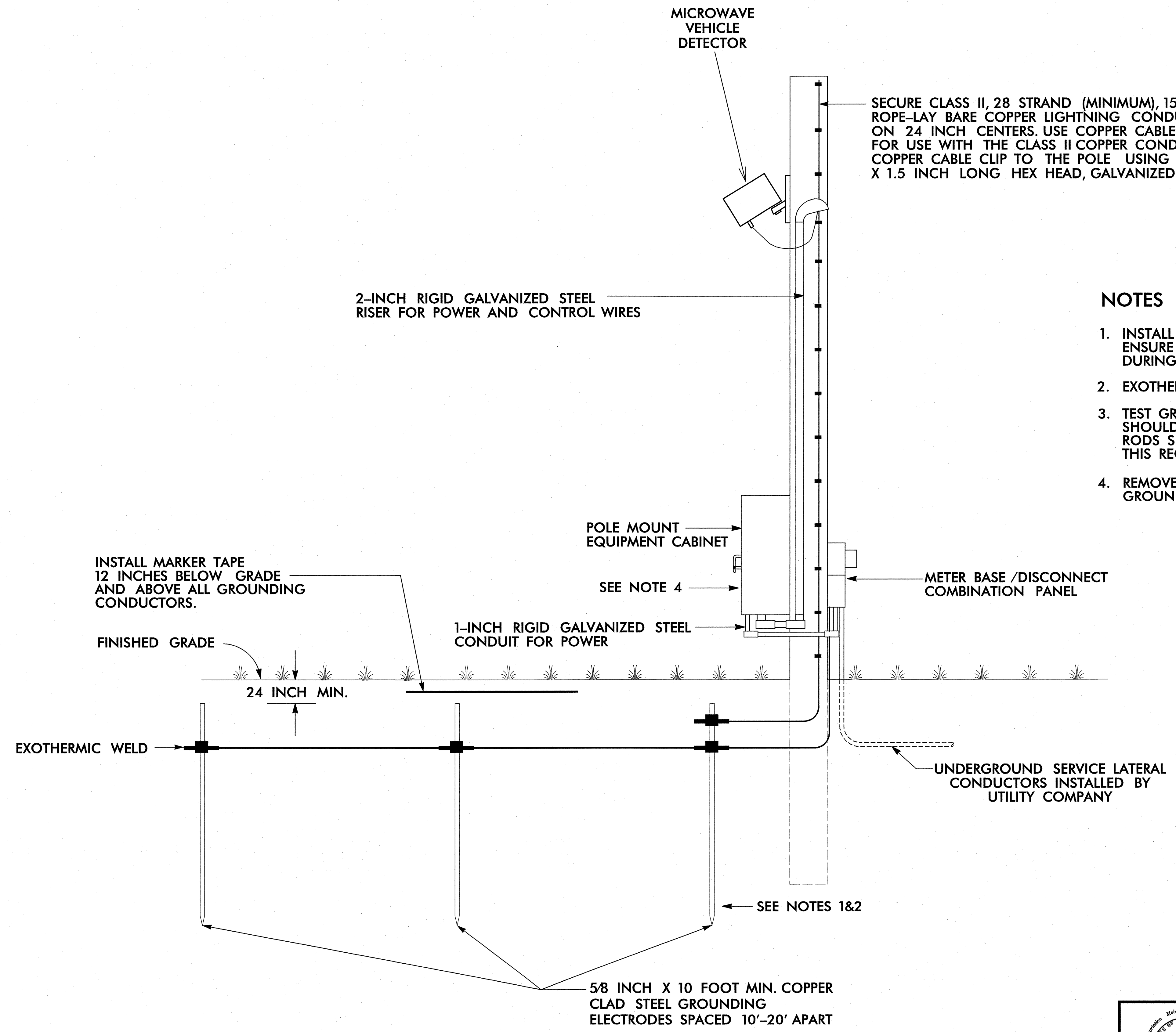

SECURE CLASS II, 28 STRAND (MINIMUM), 15 AWG (MINIMUM), ROPE-LAY BARE COPPER LIGHTNING CONDUCTOR TO THE POLE ON 24 INCH CENTERS. USE COPPER CABLE CLIPS DESIGNED FOR USE WITH THE CLASS II COPPER CONDUCTOR. SECURE EACH COPPER CABLE CLIP TO THE POLE USING A 0.25 INCH DIAMETER X 1.5 INCH LONG HEX HEAD, GALVANIZED SCREW.

2-INCH RIGID GALVANIZED STEEL RISER FOR POWER AND CONTROL WIRES

POLE MOUNT EQUIPMENT CABINET

SEE NOTE 4

METER BASE /DISCONNECT COMBINATION PANEL

INSTALL MARKER TAPE 12 INCHES BELOW GRADE AND ABOVE ALL GROUNDING CONDUCTORS.

FINISHED GRADE

1-INCH RIGID GALVANIZED STEEL CONDUIT FOR POWER

24 INCH MIN.

EXOTHERMIC WELD

UNDERGROUND SERVICE LATERAL CONDUCTORS INSTALLED BY UTILITY COMPANY

SEE NOTES 1&2

5/8 INCH X 10 FOOT MIN. COPPER CLAD STEEL GROUNDING ELECTRODES SPACED 10'-20' APART

NOTES

1. INSTALL THREE (3) GROUND RODS SPACED A MINIMUM OF 10' APART. ENSURE THAT NO EXISTING UNDERGROUND FACILITIES ARE DAMAGED DURING INSTALLATION.
2. EXOTHERMICALLY WELD ALL CONNECTIONS TO GROUND RODS.
3. TEST GROUNDING SYSTEM USING AN APPROVED METHOD. SYSTEM SHOULD MEASURE TWENTY (20) OHMS OR LESS. ADDITIONAL GROUND RODS SHALL BE INSTALLED AS DIRECTED BY THE ENGINEER TO MEET THIS REQUIREMENT.
4. REMOVE BONDING JUMPER BETWEEN EQUIPMENT CABINET GROUND BUS AND NEUTRAL BUS.

k:\real\proj_its\01038158-us_52_1ts (U-2826B)\plan\SHt 022L.dgn
 11-16-03 AM jerry.cross
 1/25/2011

PLANS PREPARED IN THE OFFICE OF:

Kimley-Horn and Associates, Inc.
 P.O. Box 33068
 Raleigh, N.C. 27636-3068
 (919) 677-2000
 N.C. License # F-0102

 750 N. Greenfield Pkwy., Garner, NC 27529
 SCALE: NONE
 0

U-2826B	
GROUNDING DETAIL FOR	
MICROWAVE VEHICLE DETECTOR	
ON WOOD POLE	
DIVISION 9	FORSYTH COUNTY WINSTON SALEM
PLAN DATE: JANUARY 2011	REVIEWED BY:
PREPARED BY: J. Cross	REVIEWED BY: S. Privette
REVISIONS	INIT. DATE

SEAL

 SIGNATURE: DATE: 1-25-11
 CADD Filename:

QUANTITIES

1/25/2011 11:45:04 AM jerry.cross k:\nal_tproj_its\01036158-us_52_its (U-2826B)\plan\shd 013.dgn

PLANS PREPARED IN
 THE OFFICE OF:

**Kimley-Horn
 and Associates, Inc.**
 P.O. Box 33068
 Raleigh, N.C. 27636-3068
 (919) 677-2000
 N.C. License # F-0102

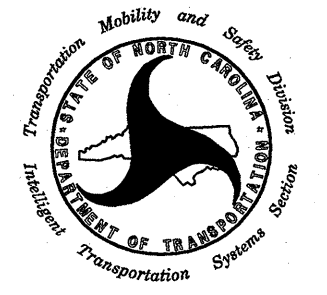
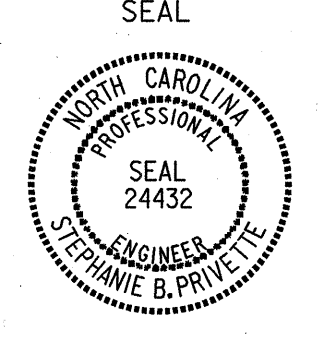
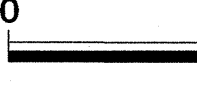
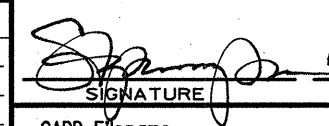
 <small>750 N. Greenfield Pkwy., Garner, NC 27529</small>	U-2826B QUANTITIES		SEAL  NORTH CAROLINA PROFESSIONAL SEAL 24432 ENGINEER STEPHANIE B. PRIVETTE
	DIVISION 9 FORSYTH COUNTY WINSTON SALEM		
PLAN DATE: JANUARY 2011	REVIEWED BY:		
PREPARED BY: J. Cross	REVIEWED BY: S. Privette		
SCALE 0 	REVISIONS	INIT.	DATE
			SIGNATURE:  DATE: 1-25-11 CADD Filenames:

DMS POLE LOCATION
N 36°11.675'
W 80°17.240'

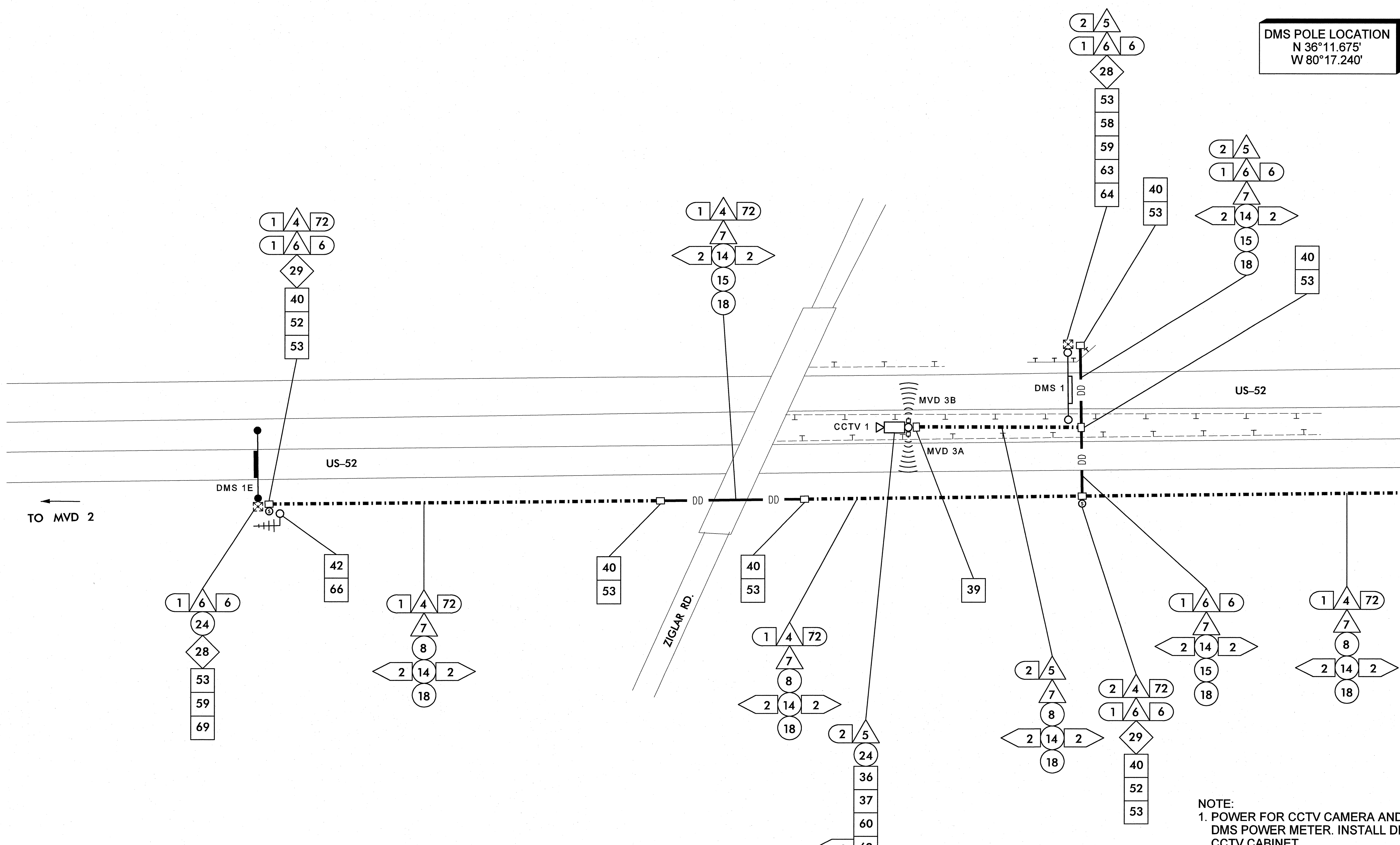

← TO MVD 2

MATCH LINE, SEE SHEET 5

NOTE:
1. POWER FOR CCTV CAMERA AND CABINET FROM DMS POWER METER. INSTALL DISCONNECT AT CCTV CABINET.

NOTE 1

1/25/2011 11:46:05 AM jerry.cross
k:\real_time\its\0108658-us 52.its (u-2826B)\plan\sh4-004.dgn

PLANS PREPARED IN THE OFFICE OF:
Kimley-Horn and Associates, Inc.
P.O. Box 33068
Raleigh N.C. 27636-3068
(919) 677-2000
N.C. License # F-0102



U - 2826B			
CABLE ROUTING PLAN SHEET			
DIVISION 9 FORSYTH COUNTY		WINSTON SALEM	
PLAN DATE: JANUARY 2011	REVIEWED BY:		
PREPARED BY: J. Cross	REVIEWED BY: S. Privette		
REVISIONS	INIT.	DATE	

SEAL
NORTH CAROLINA PROFESSIONAL ENGINEER
STEPHANIE B. PRIVETTE
SEAL 24432
1-25-11
DATE
CADD Filename:

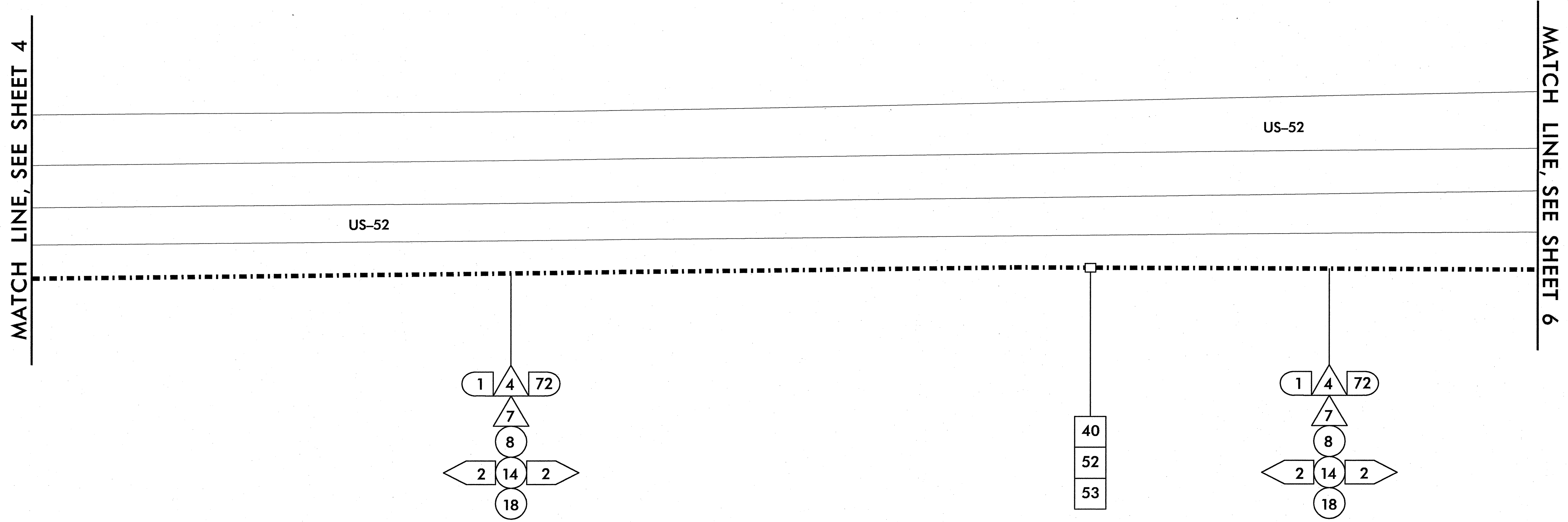

1/25/2011 11:45:09 AM jerry.cross k:\real_proj_its\01086158-us_52_its (U-2826B)\plan\sh4.dwg

PLANS PREPARED IN THE OFFICE OF:

Kimley-Horn and Associates, Inc.
 P.O. Box 33068
 Raleigh, N.C. 27636-3068
 (919) 677-2000
 N.C. License # F-0102

750 N. Greenfield Pkwy., Garner, NC 27529
 SCALE
 0 50

U-2826B	
CABLE ROUTING PLAN SHEET	
DIVISION 9 FORSYTH COUNTY WINSTON SALEM	
PLAN DATE: JANUARY 2011	REVIEWED BY:
PREPARED BY: J. Cross	REVIEWED BY: S. Privette
REVISIONS	INIT. DATE

SEAL

SIGNATURE: *Stephanie B. Privette* DATE: 1-25-11
 CADD Filename:

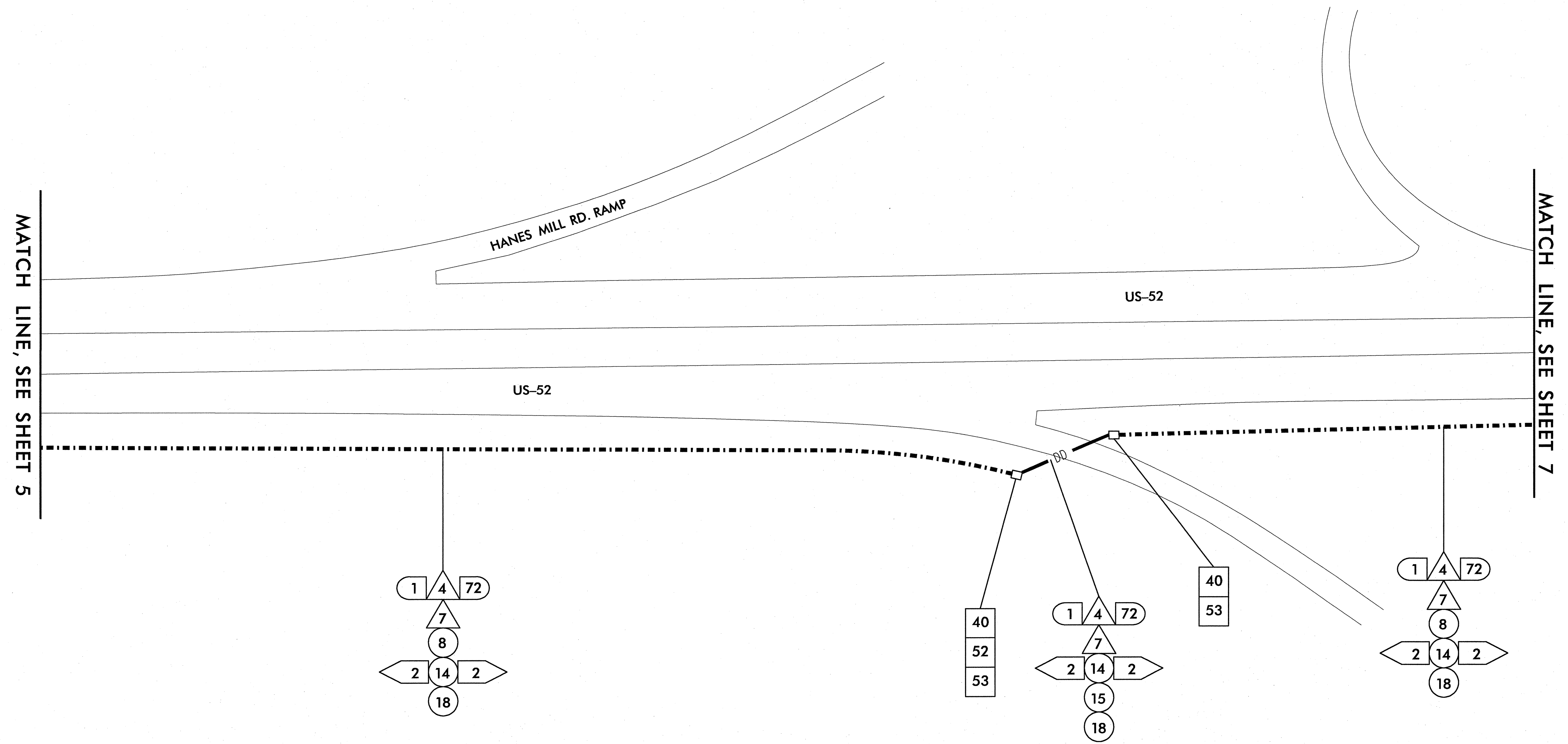

1/25/2011 11:46:07 AM jerry.cross k:\rel_ppro_its\01\086159.us 52.its (U-2826B)\plan\shp_006.dgn

PLANS PREPARED IN THE OFFICE OF:

Kimley-Horn and Associates, Inc.
 P.O. Box 33068
 Raleigh, N.C. 27636-3068
 (919) 677-2000
 N.C. License # F-002

750 N. Greenfield Pkwy., Garner, NC 27529
 SCALE 0 50

U-2826B	
CABLE ROUTING PLAN SHEET	
DIVISION 9 FORSYTH COUNTY WINSTON SALEM	
PLAN DATE: JANUARY 2011	REVIEWED BY:
PREPARED BY: J. Cross	REVIEWED BY: S. Privette
REVISIONS	INIT. DATE

SEAL

SIGNATURE: DATE: 1-25-11
 CAD File Name:

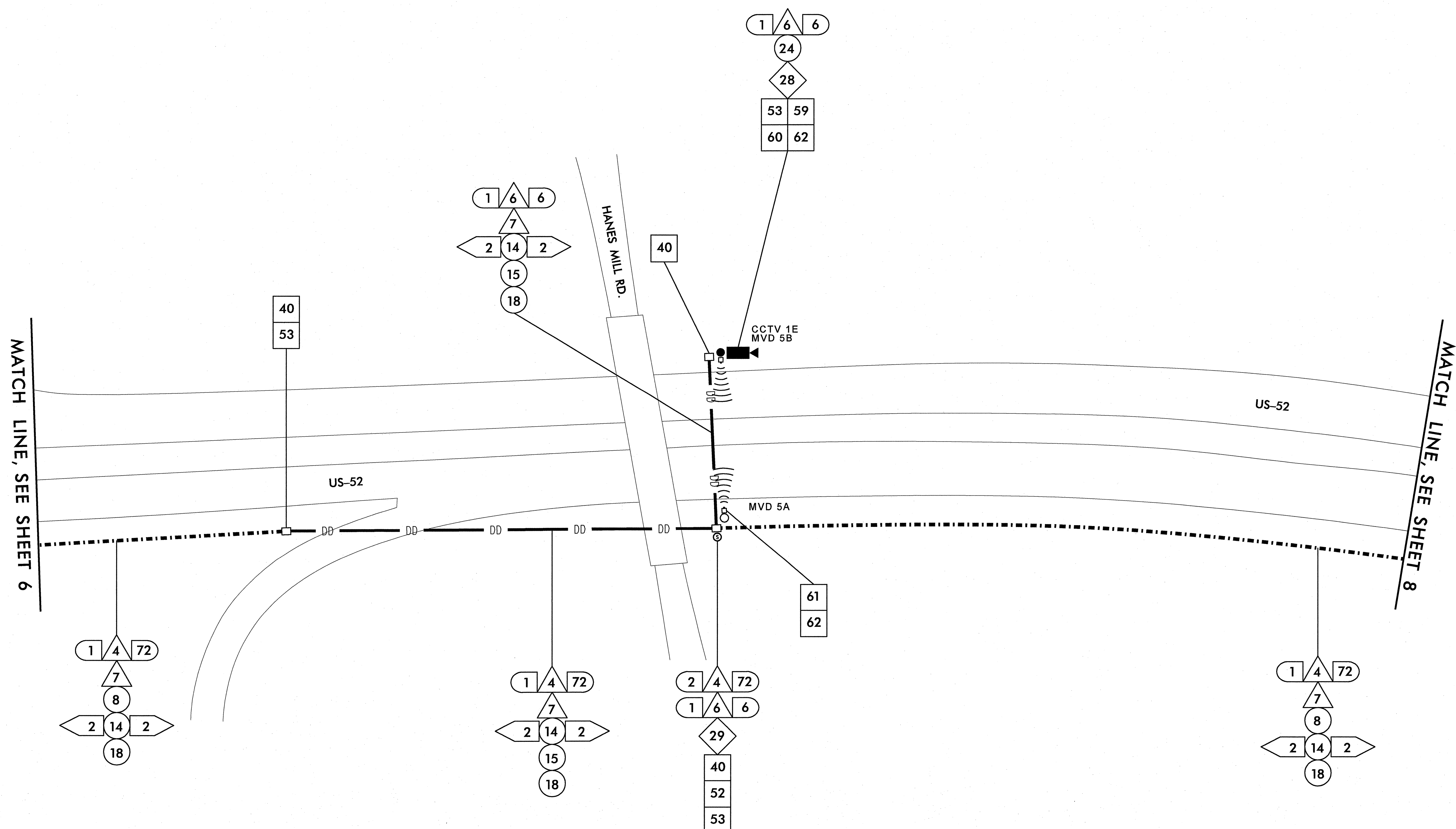

k:\real_tproj_tts\011056158-us 52_tts (u-2826B)\plan\Sheet 007.dgn
 1/25/2011 11:46:09 AM jerry.cross

PLANS PREPARED IN THE OFFICE OF:

Kimley-Horn and Associates, Inc.
 P.O. Box 33068
 Raleigh, N.C. 27636-3068
 (919) 677-2000
 N.C. License # F-0102

750 N. Greenfield Pkwy., Garner, NC 27529

U-2826B	
CABLE ROUTING PLAN SHEET	
DIVISION 9 FORSYTH COUNTY WINSTON SALEM	
PLAN DATE: JANUARY 2011	REVIEWED BY:
PREPARED BY: J. Cross	REVIEWED BY: S. Privette
REVISIONS	INIT. DATE

SEAL

SIGNATURE DATE 1-25-11
 CADD Filename:

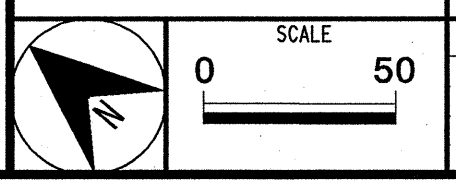

MATCH LINE, SEE SHEET 7

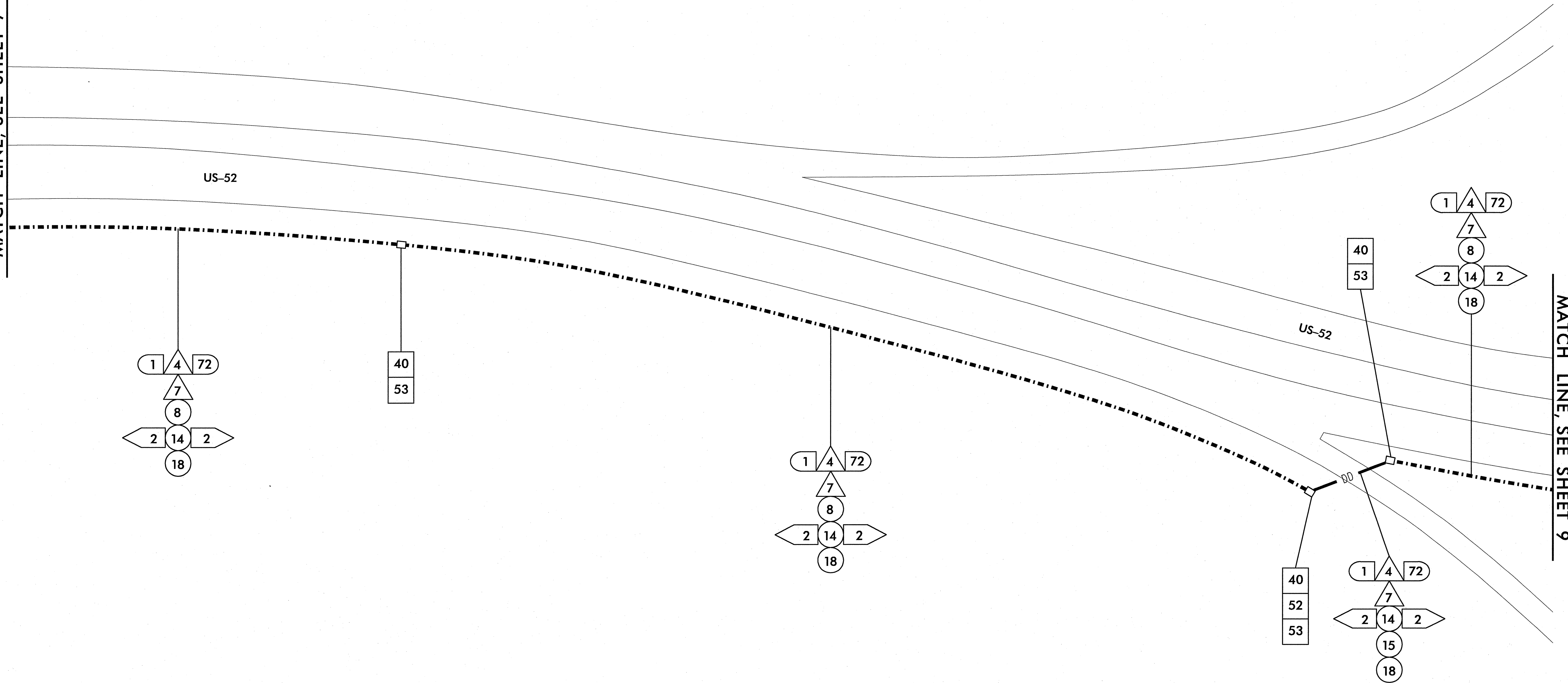

MATCH LINE, SEE SHEET 9

k:\ra1_ppro_its\01\086158-us-52_its (U-2826B)\plan\sh9_008.dgn

11:46:09 AM jerry.cross

1/25/2011

PLANS PREPARED IN THE OFFICE OF:

Kimley-Horn and Associates, Inc.
 P.O. Box 33068
 Raleigh, N.C. 27636-3068
 (919) 677-2000
 N.C. License # F-0102

 750 N. Greenfield Pkwy., Garner, NC 27529
 SCALE: 0 50

U-2826B	
CABLE ROUTING PLAN SHEET	
DIVISION 9 FORSYTH COUNTY WINSTON SALEM	
PLAN DATE: JANUARY 2011	REVIEWED BY:
PREPARED BY: J. Cross	REVIEWED BY: S. Privette
REVISIONS	INIT. DATE

SEAL

 SIGNATURE: DATE: 1-25-11
 CAD: Filername

MATCH LINE, SEE SHEET 29

MATCH LINE, SEE SHEET 30

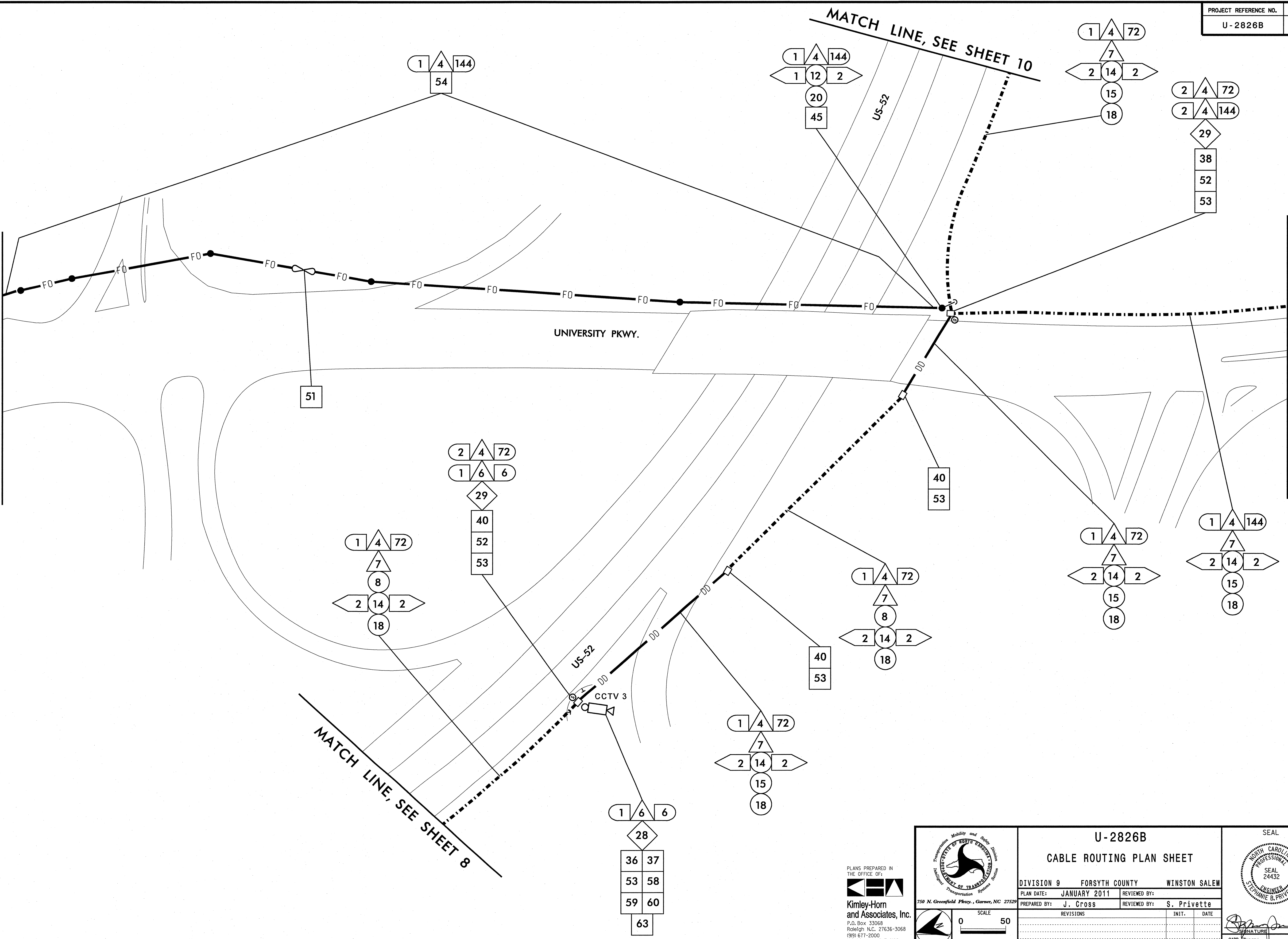

k:\ral_tproj_its\01080508-us 52_its (u-2826B)\plan\shd 008.dgn
11-16-10 JM jerry.cross
1/25/2011

MATCH LINE, SEE SHEET 8

MATCH LINE, SEE SHEET 10

PLANS PREPARED IN THE OFFICE OF:

Kimley-Horn and Associates, Inc.
P.O. Box 33068
Raleigh, N.C. 27636-3068
(919) 677-2000
N.C. License # F-0102

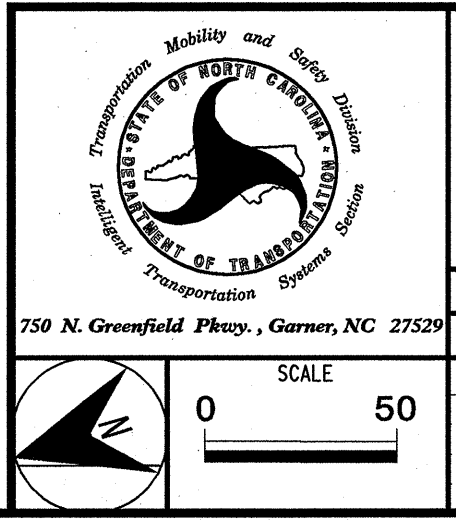

U-2826B	
CABLE ROUTING PLAN SHEET	
DIVISION 9 FORSYTH COUNTY WINSTON SALEM	
PLAN DATE: JANUARY 2011	REVIEWED BY:
PREPARED BY: J. Cross	REVIEWED BY: S. Privette
REVISIONS	INIT. DATE

SEAL

STEPHANIE B. PRIVETTE
1-25-11
DATE
CADD Filenames

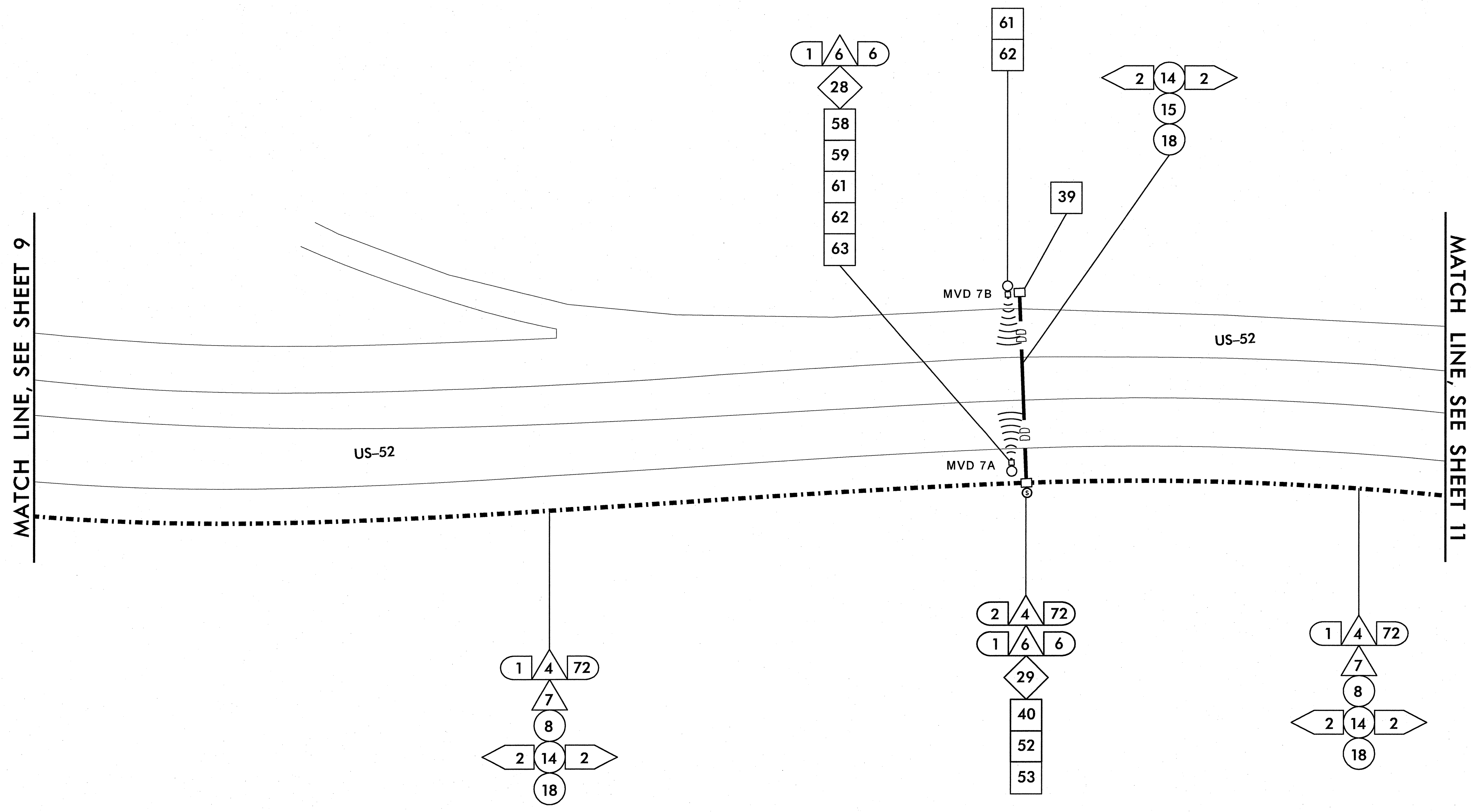

k:\ncal_tproj_its\01056158-us 52_its (u-2826b)\plan\st 010.dgn
 11:46:17 AM jerry.cross
 1/25/2011

PLANS PREPARED IN
 THE OFFICE OF:

**Kimley-Horn
 and Associates, Inc.**
 P.O. Box 33068
 Raleigh N.C. 27636-3068
 (919) 677-2000
 N.C. License # F-0102

750 N. Greenfield Pkwy., Garner, NC 27529
 SCALE
 0 50

U-2826B	
CABLE ROUTING PLAN SHEET	
DIVISION 9 FORSYTH COUNTY WINSTON SALEM	
PLAN DATE: JANUARY 2011	REVIEWED BY:
PREPARED BY: J. Cross	REVIEWED BY: S. Privette
REVISIONS	INIT. DATE

SEAL

SIGNATURE: *Stephanie B. Privette* DATE: 1-25-11
 CADD Filename:

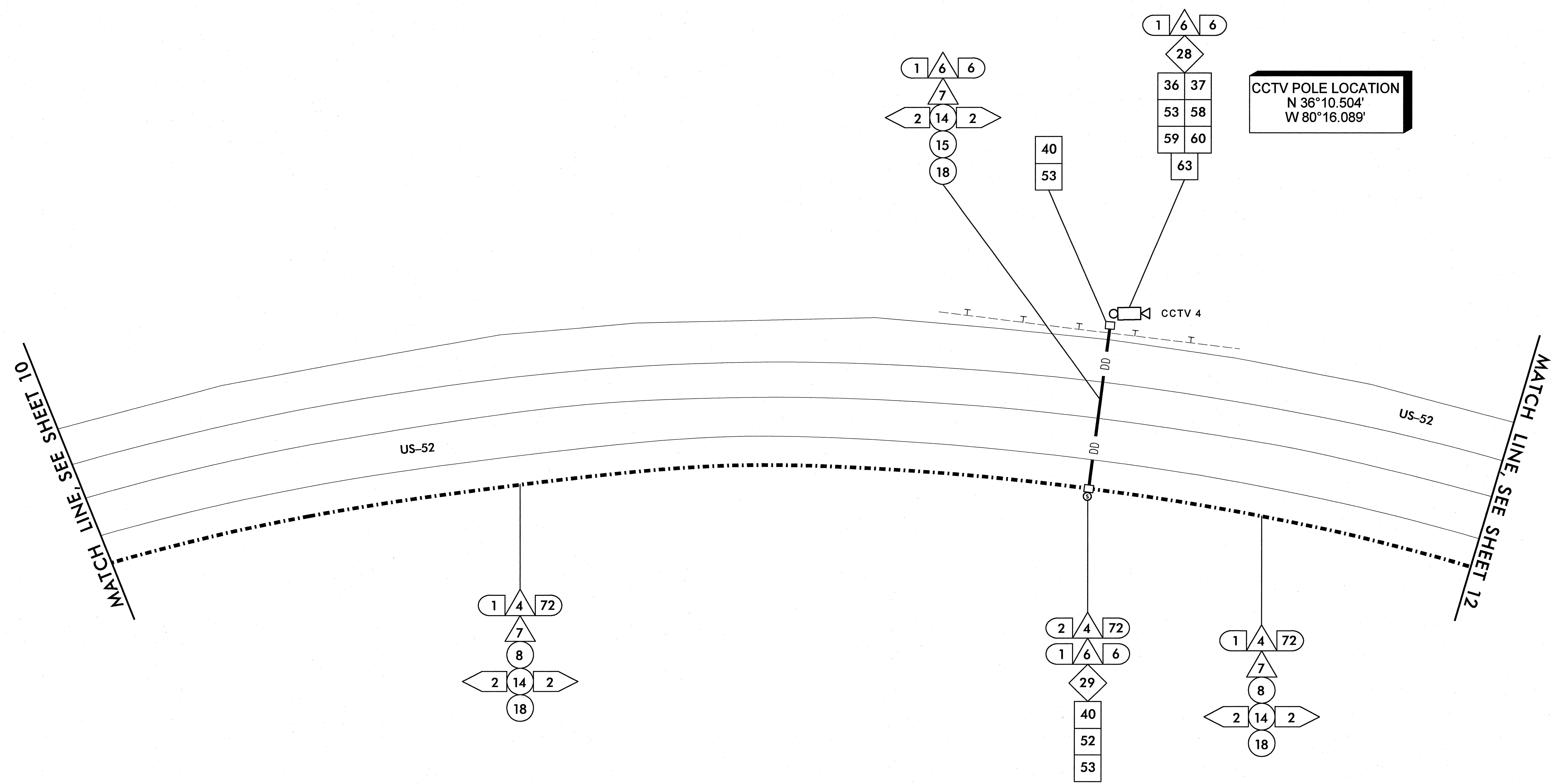

CCTV POLE LOCATION
 N 36°10.504'
 W 80°16.089'

1/25/2011 11:46:12 AM jerry.cross k:\ra1\proj_its\0108858-us_52_its\0-2826B\plan\sh1011.dgn

PLANS PREPARED IN THE OFFICE OF:

Kimley-Horn and Associates, Inc.
 P.O. Box 33068
 Raleigh, N.C. 27636-3068
 (919) 677-2000
 N.C. License # F-0102

750 N. Greenfield Pkwy., Garner, NC 27529

U-2826B	
CABLE ROUTING PLAN SHEET	
DIVISION 9 FORSYTH COUNTY WINSTON SALEM	
PLAN DATE: JANUARY 2011	REVIEWED BY:
PREPARED BY: J. Cross	REVIEWED BY: S. Privette
SCALE: 0 50	REVISIONS
INIT.	DATE

SEAL

STEPHANIE B. PRIVETTE
 ENGINEER
 1-25-11
 SIGNATURE DATE
 CADD Filename:

MATCH LINE, SEE SHEET 11

MATCH LINE, SEE SHEET 13

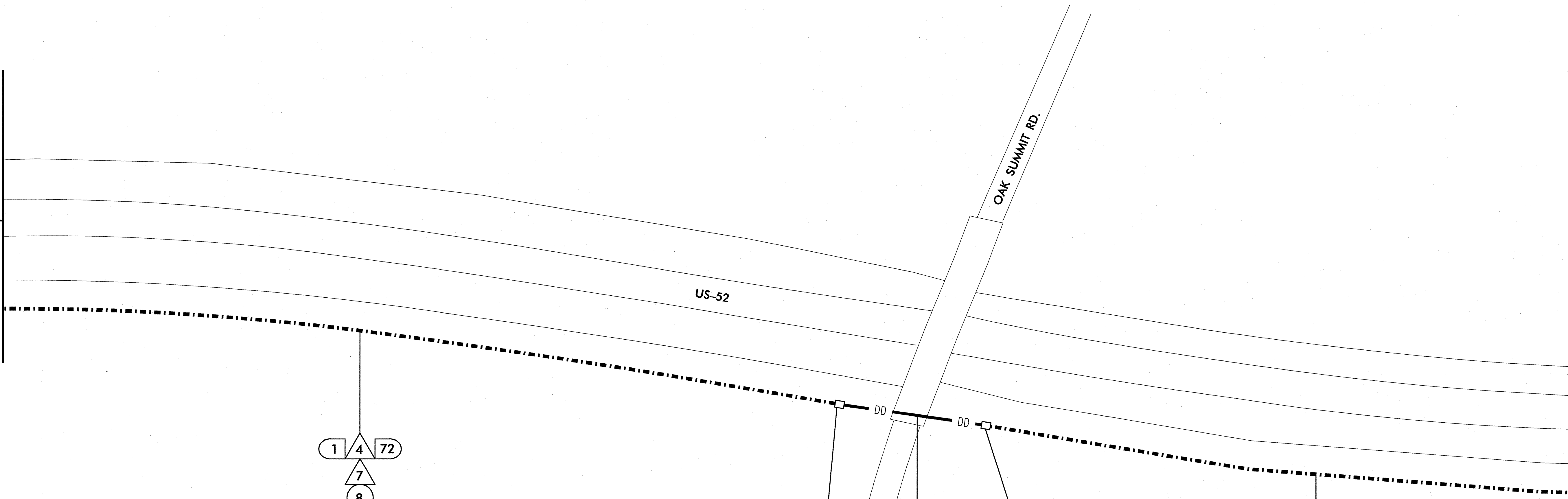

1/25/2011 11:46:19 AM jerry.cross k:\val_tproj_its\01026188-us 52_its (u-2826B)\plan\sh1 012.dgn

PLANS PREPARED IN THE OFFICE OF:

Kimley-Horn and Associates, Inc.
 P.O. Box 33068
 Raleigh N.C. 27636-3068
 (919) 677-2000
 N.C. License # F-0102

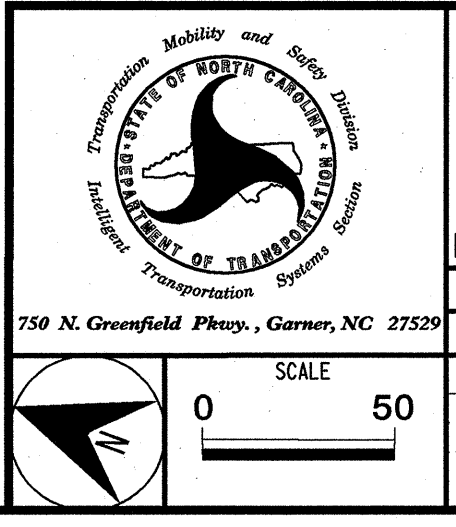

U-2826B	
CABLE ROUTING PLAN SHEET	
DIVISION 9 FORSYTH COUNTY WINSTON SALEM	
PLAN DATE: JANUARY 2011	REVIEWED BY:
PREPARED BY: J. Cross	REVIEWED BY: S. Privette
REVISIONS	INIT. DATE

SEAL

SIGNATURE DATE 1-25-11
 CADD Filename:

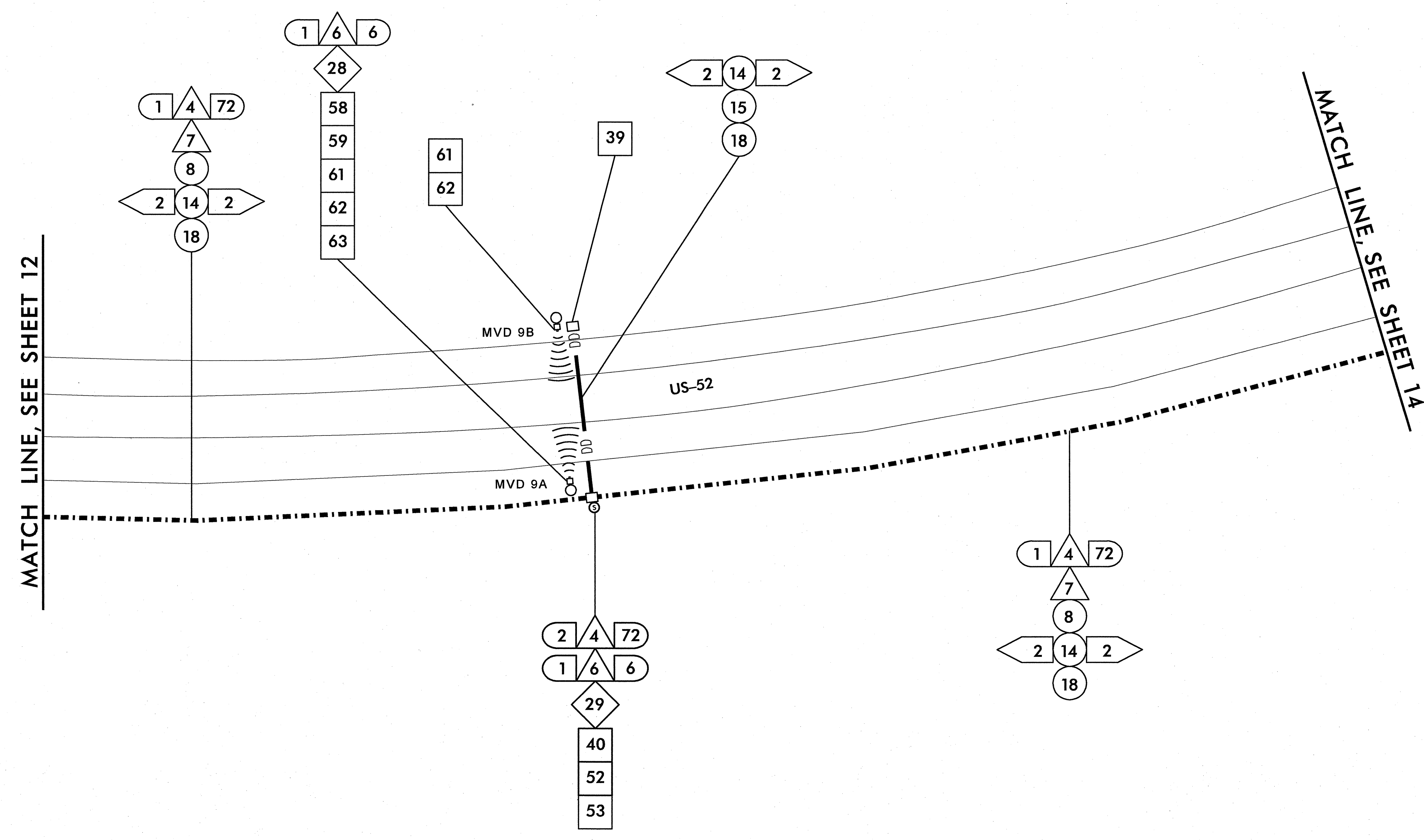

1/25/2011 11:46:14 AM jerry.cross k:\ra1\proj_its\0108858-us_52_its (u-2826B)\plan\sh1 013.dgn

PLANS PREPARED IN THE OFFICE OF:

Kimley-Horn and Associates, Inc.
 P.O. Box 33068
 Raleigh, N.C. 27636-3068
 (919) 677-2000
 N.C. License # F-0102

750 N. Greenfield Pkwy., Garner, NC 27529
 SCALE: 0 50

U-2826B	
CABLE ROUTING PLAN SHEET	
DIVISION 9 FORSYTH COUNTY WINSTON SALEM	
PLAN DATE: JANUARY 2011	REVIEWED BY:
PREPARED BY: J. Cross	REVIEWED BY: S. Privette
REVISIONS	INIT. DATE

SEAL

SIGNATURE: *Stephanie B. Privette* DATE: 1-25-11
 CADD Filename:

MATCH LINE, SEE SHEET 13

MATCH LINE, SEE SHEET 15

US-52

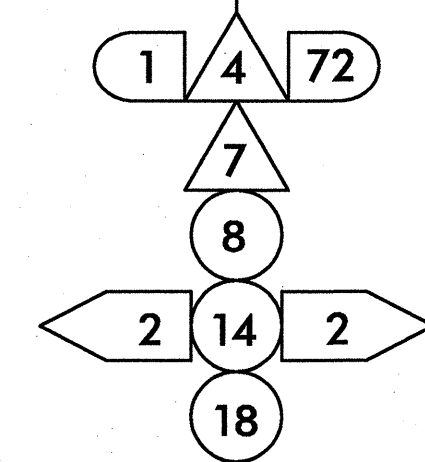
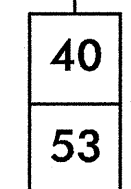
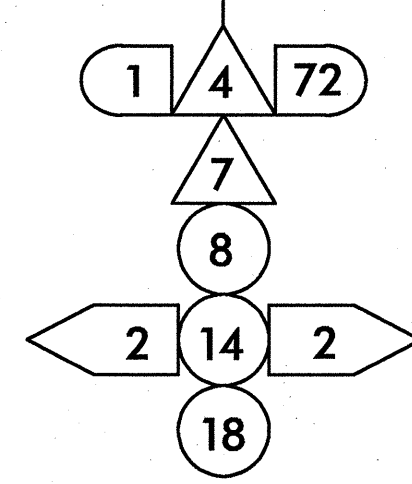

1/25/2011 11:46:15 AM jerry.cross k:\ral\proj_its\01086158-us 52_its (U-2826B)\plan\shc 014.dgn

PLANS PREPARED IN THE OFFICE OF:

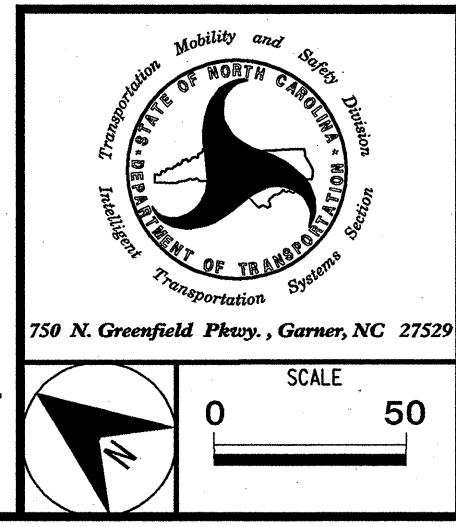
Kimley-Horn and Associates, Inc.
 P.O. Box 33068
 Raleigh N.C. 27636-3068
 (919) 677-2000
 N.C. License # F-0102

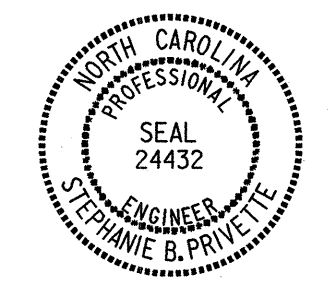

U-2826B	
CABLE ROUTING PLAN SHEET	
DIVISION 9	FORSYTH COUNTY WINSTON SALEM
PLAN DATE: JANUARY 2011	REVIEWED BY:
PREPARED BY: J. Cross	REVIEWED BY: S. Privette
REVISIONS	INIT. DATE

SEAL



STEPHANIE B. PRIVETTE
 ENGINEER
 No. 24432

[Signature] 1-25-11
 DATE

CADD Filename: V

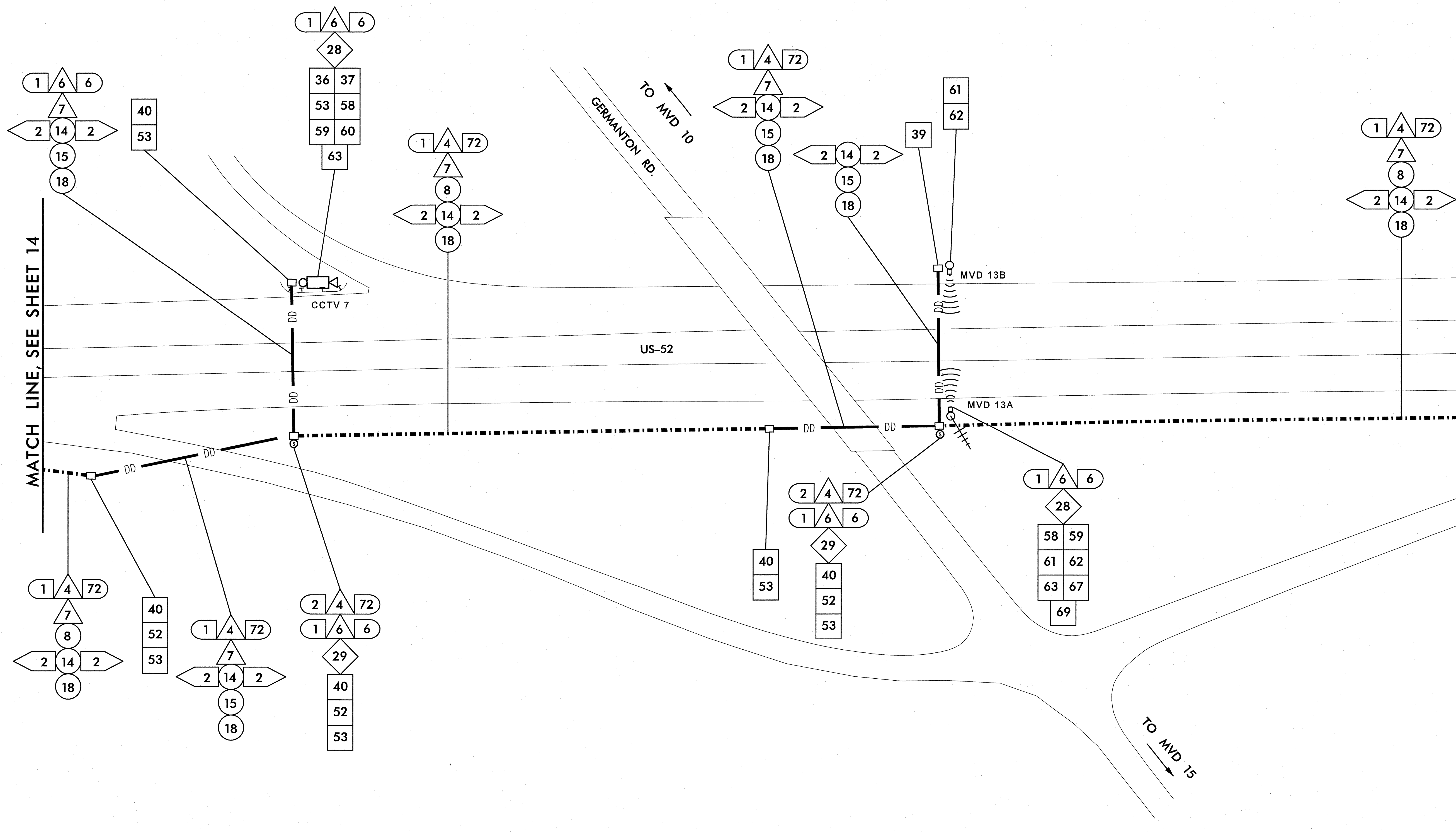

k:\real\proj\its\15\10286B-us_52_11s (U-2826B)\plan\Sh1 015.dgn
 11:46:16 AM jerry.cross
 1/25/2011

PLANS PREPARED IN THE OFFICE OF:

Kimley-Horn and Associates, Inc.
 P.O. Box 33068
 Raleigh, N.C. 27636-3068
 (919) 677-2000
 N.C. License # F-0102

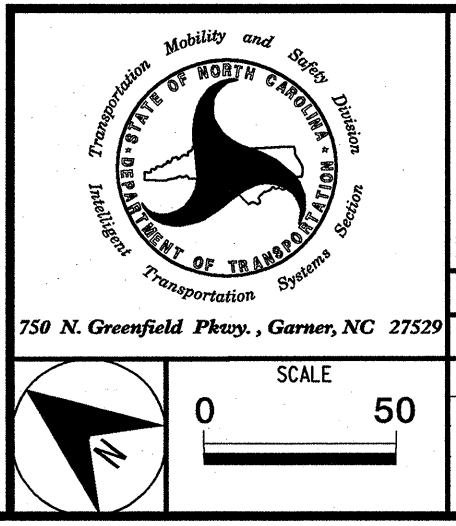

U-2826B	
CABLE ROUTING PLAN SHEET	
DIVISION 9 FORSYTH COUNTY WINSTON SALEM	
PLAN DATE: JANUARY 2011	REVIEWED BY:
PREPARED BY: J. Cross	REVIEWED BY: S. Privette
REVISIONS	INIT. DATE

SEAL

 SIGNATURE: *Stephanie B. Privette* 1/25/11
 DATE: 1/25/11
 CADD: *[Signature]*

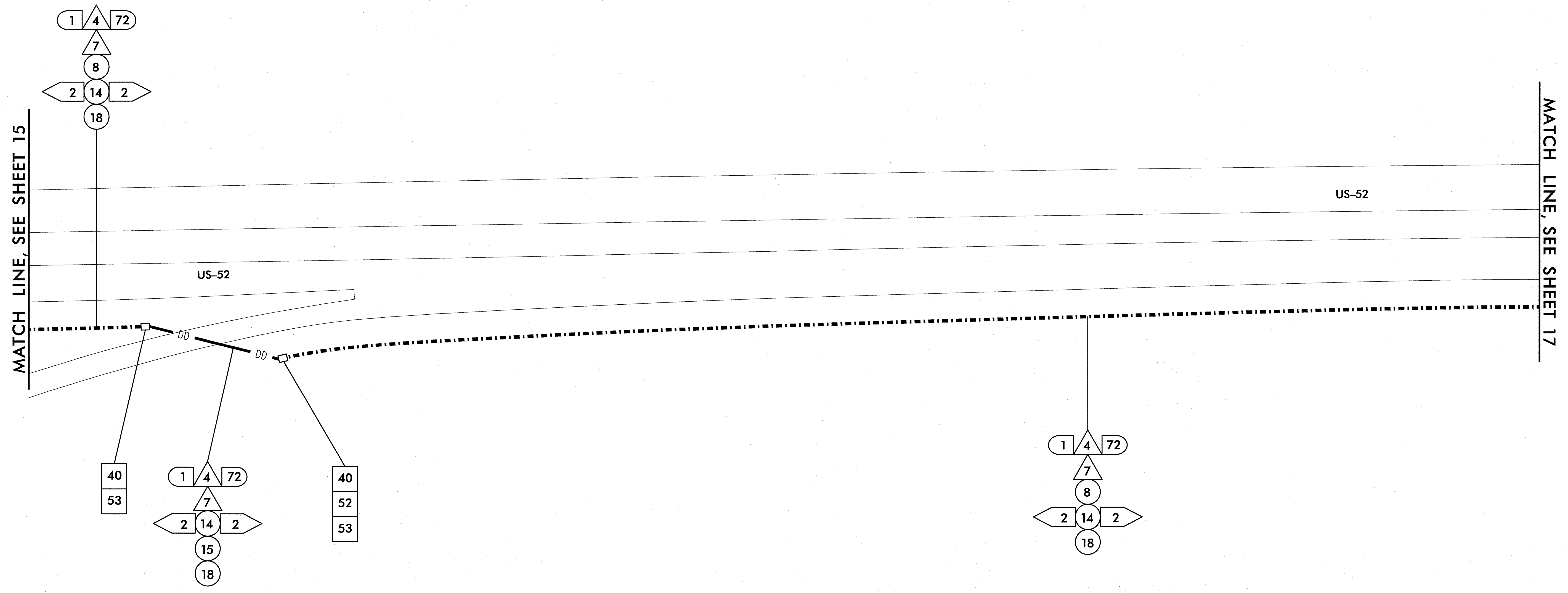

1/25/2011 11:46:17 AM jerry.cross k:\val_tproj_its\1026168-us_52_1ts (U-2826B)\plan\sh1 c16.dgn

PLANS PREPARED IN THE OFFICE OF:

Kimley-Horn and Associates, Inc.
 P.O. Box 33068
 Raleigh N.C. 27636-3068
 (919) 677-2000
 N.C. License # F-0102

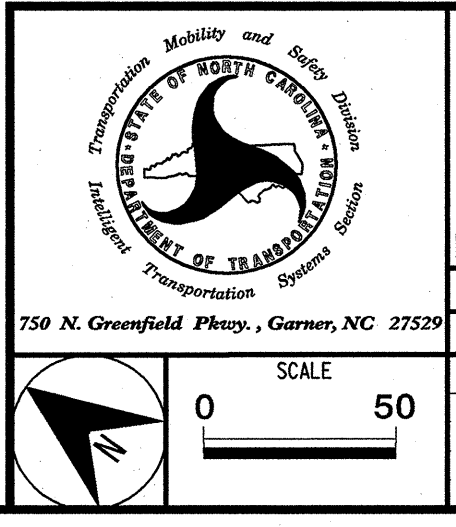

U-2826B	
CABLE ROUTING PLAN SHEET	
DIVISION 9 FORSYTH COUNTY WINSTON SALEM	
PLAN DATE: JANUARY 2011	REVIEWED BY:
PREPARED BY: J. Cross	REVIEWED BY: S. Privette
REVISIONS	INIT. DATE

SEAL

SIGNATURE: *Stephanie B. Privette* DATE: 1.25.11
 CADD filename:

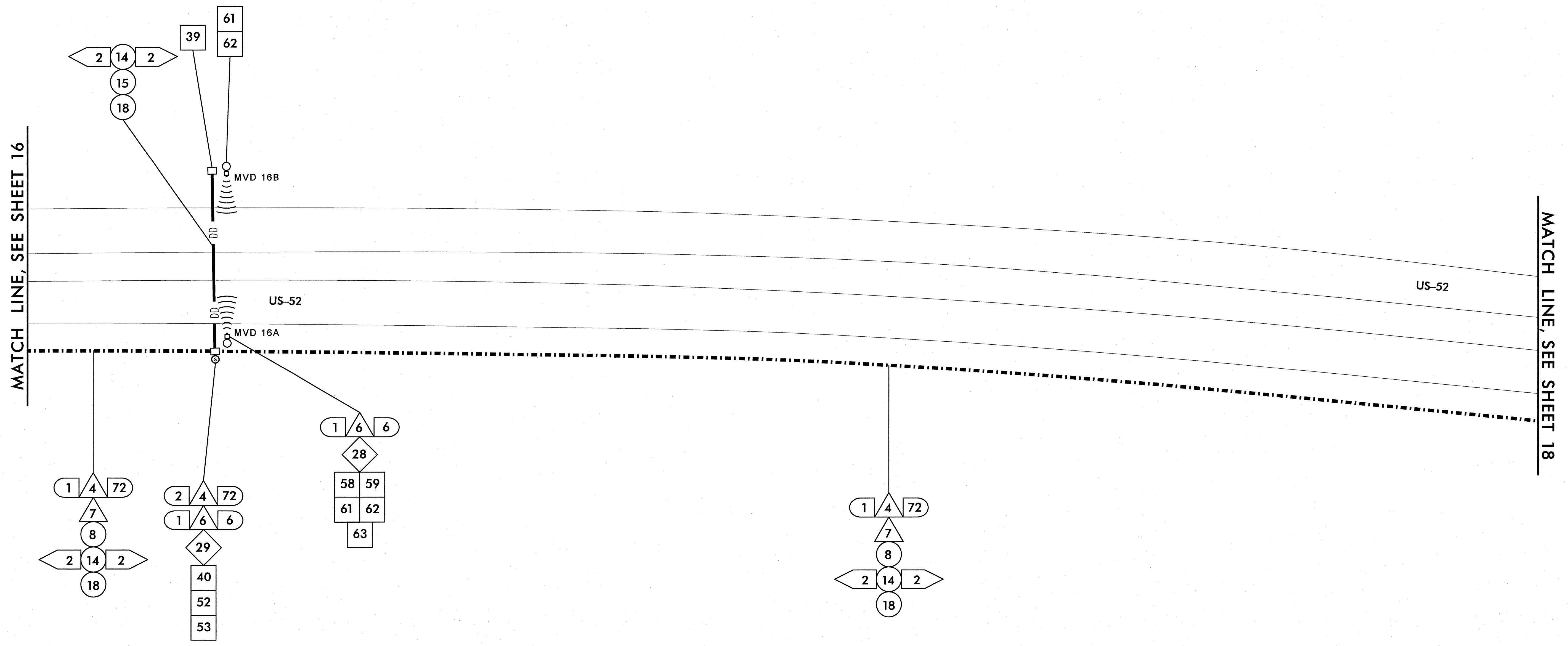

1/25/2011 11:46:16 AM jerry.cross k:\val_tproj_its\0105658-us 52_its (u-2826B)\plan_sht 017.dgn

PLANS PREPARED IN THE OFFICE OF:

Kimley-Horn and Associates, Inc.
 P.O. Box 33068
 Raleigh N.C. 27636-3068
 (919) 677-2000
 N.C. License # F-002

NORTH CAROLINA PROFESSIONAL ENGINEER
 SEAL
 24432
 STEPHANIE B. PRIVETTE

U-2826B	
CABLE ROUTING PLAN SHEET	
DIVISION 9 FORSYTH COUNTY WINSTON SALEM	
PLAN DATE: JANUARY 2011	REVIEWED BY:
PREPARED BY: J. Cross	REVIEWED BY: S. Privette
REVISIONS	INIT. DATE

SEAL

 SIGNATURE: *Stephanie B. Privette* 1-25-11
 DATE: 1-25-11
 CADD Filename:

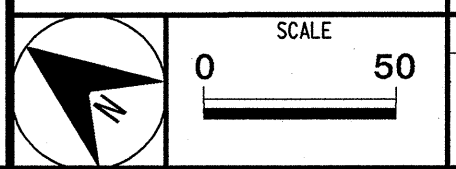

MATCH LINE, SEE SHEET 17

MATCH LINE, SEE SHEET 19

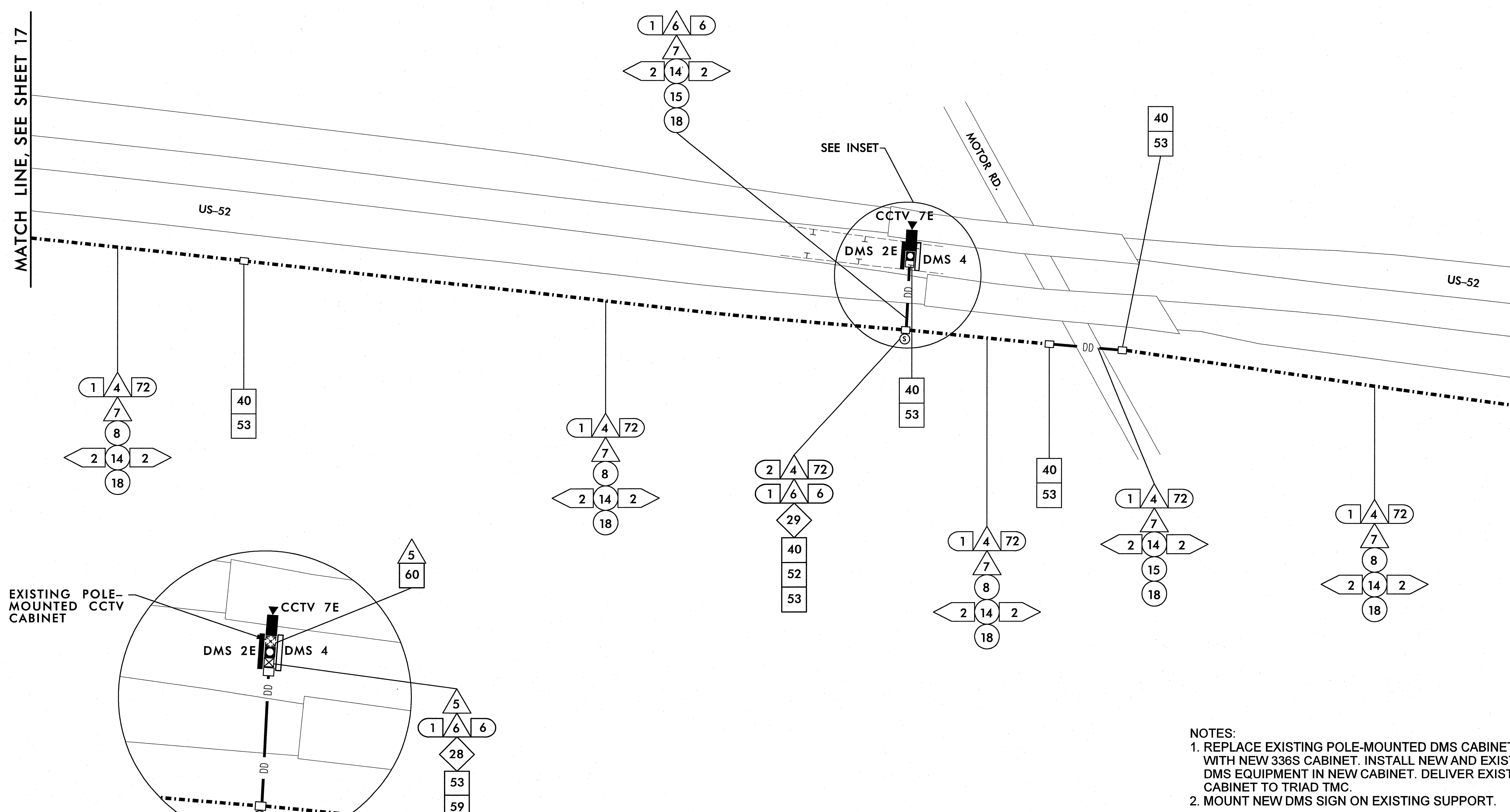

EXISTING POLE-MOUNTED CCTV CABINET

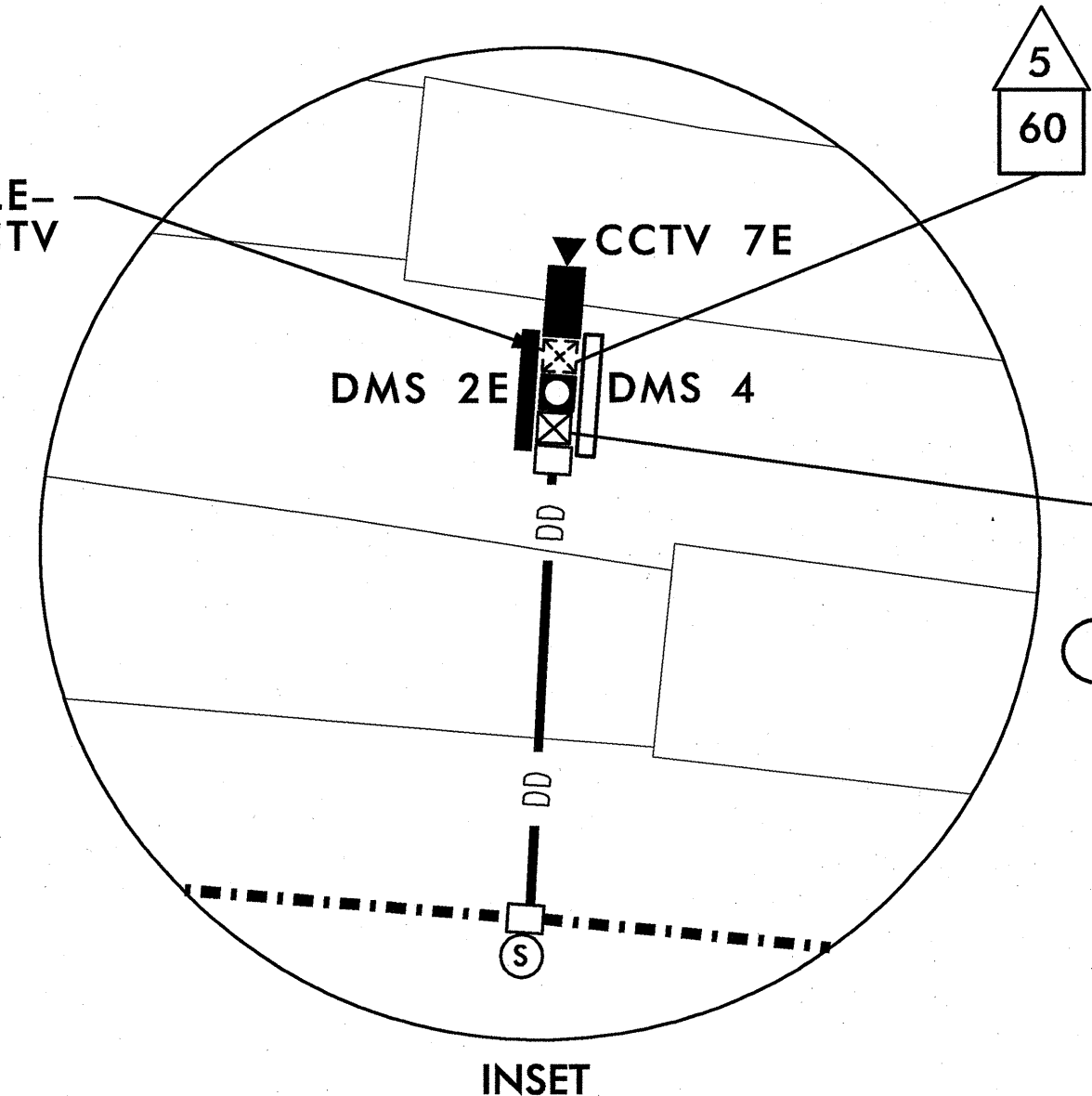

- 53
- 59
- 63 SEE NOTE 1
- 64 SEE NOTE 2

NOTES:

1. REPLACE EXISTING POLE-MOUNTED DMS CABINET WITH NEW 336S CABINET. INSTALL NEW AND EXISTING DMS EQUIPMENT IN NEW CABINET. DELIVER EXISTING CABINET TO TRIAD TMC.
2. MOUNT NEW DMS SIGN ON EXISTING SUPPORT.

1/25/2011 11:46:19 AM jerry.cross k:\a1_tproj_its\01038158-us_52_its (u-2826b)\plan\sh1 018.dgn

PLANS PREPARED IN THE OFFICE OF:

Kimley-Horn and Associates, Inc.
 P.O. Box 33068
 Raleigh, N.C. 27636-3068
 (919) 677-2000
 N.C. License # F-0102

750 N. Greenfield Pkwy., Garner, NC 27529

U-2826B	
CABLE ROUTING PLAN SHEET	
DIVISION 9 FORSYTH COUNTY WINSTON SALEM	
PLAN DATE: JANUARY 2011	REVIEWED BY:
PREPARED BY: J. Cross	REVIEWED BY: S. Privette
SCALE: 0 50	REVISIONS
	INIT. DATE

SEAL

STEPHANIE B. PRIVETTE
 ENGINEER
 1-25-11
 DATE

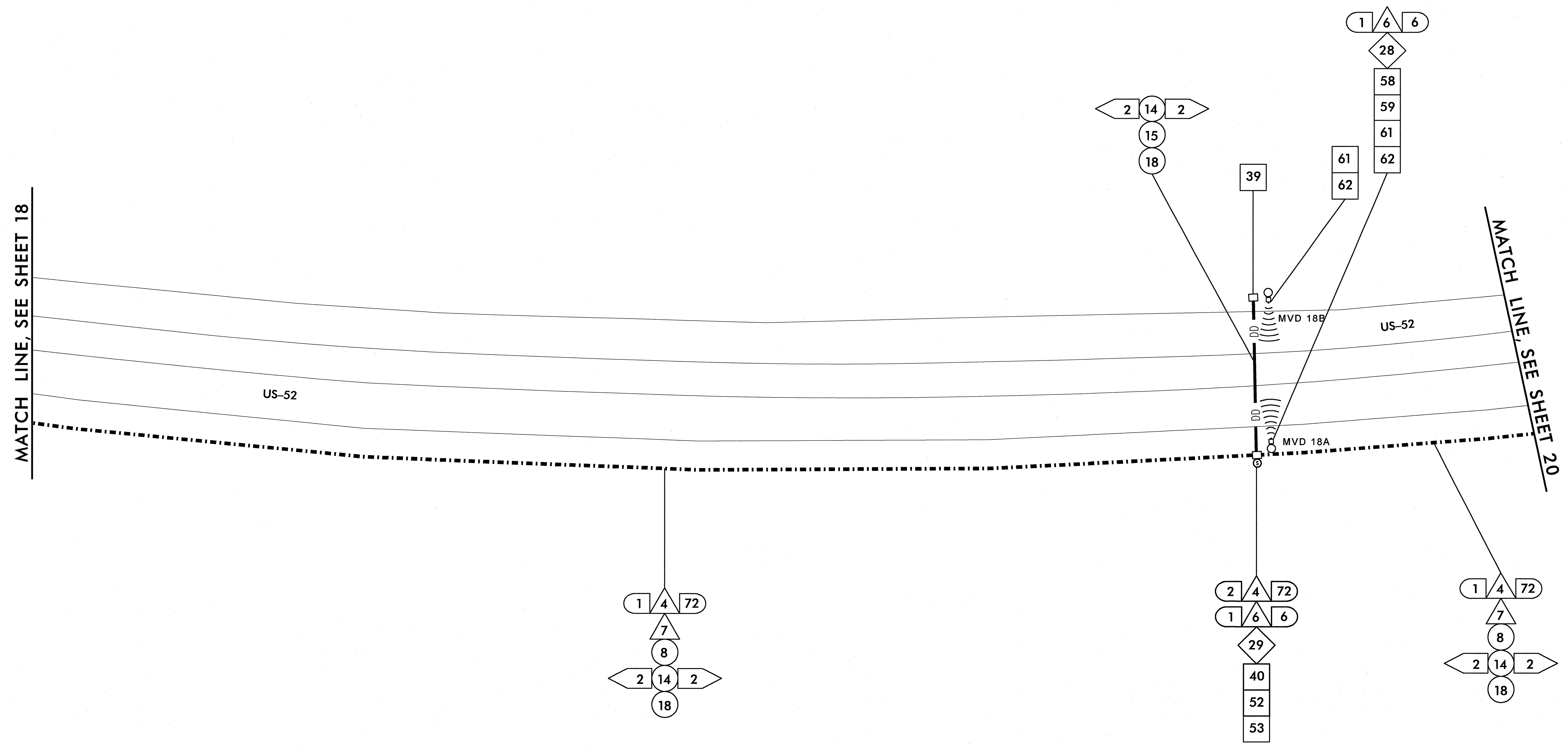

1/25/2011 11:46:21 AM jerry.cross k:\rd\proj\its\01038658-us_52_1ts (U-2826B)\plan\sh1 019.dgn

PLANS PREPARED IN THE OFFICE OF:

Kimley-Horn and Associates, Inc.
 P.O. Box 33068
 Raleigh, N.C. 27636-3068
 (919) 677-2000
 N.C. License # F-0102

750 N. Greenfield Pkwy., Garner, NC 27529

U-2826B	
CABLE ROUTING PLAN SHEET	
DIVISION 9 FORSYTH COUNTY WINSTON SALEM	
PLAN DATE: JANUARY 2011	REVIEWED BY:
PREPARED BY: J. Cross	REVIEWED BY: S. Privette
REVISIONS	INIT. DATE

SEAL

SIGNATURE: *Stephanie B. Privette* DATE: 1-25-11

CADD filename:

MATCH LINE, SEE SHEET 19

MATCH LINE, SEE SHEET 21

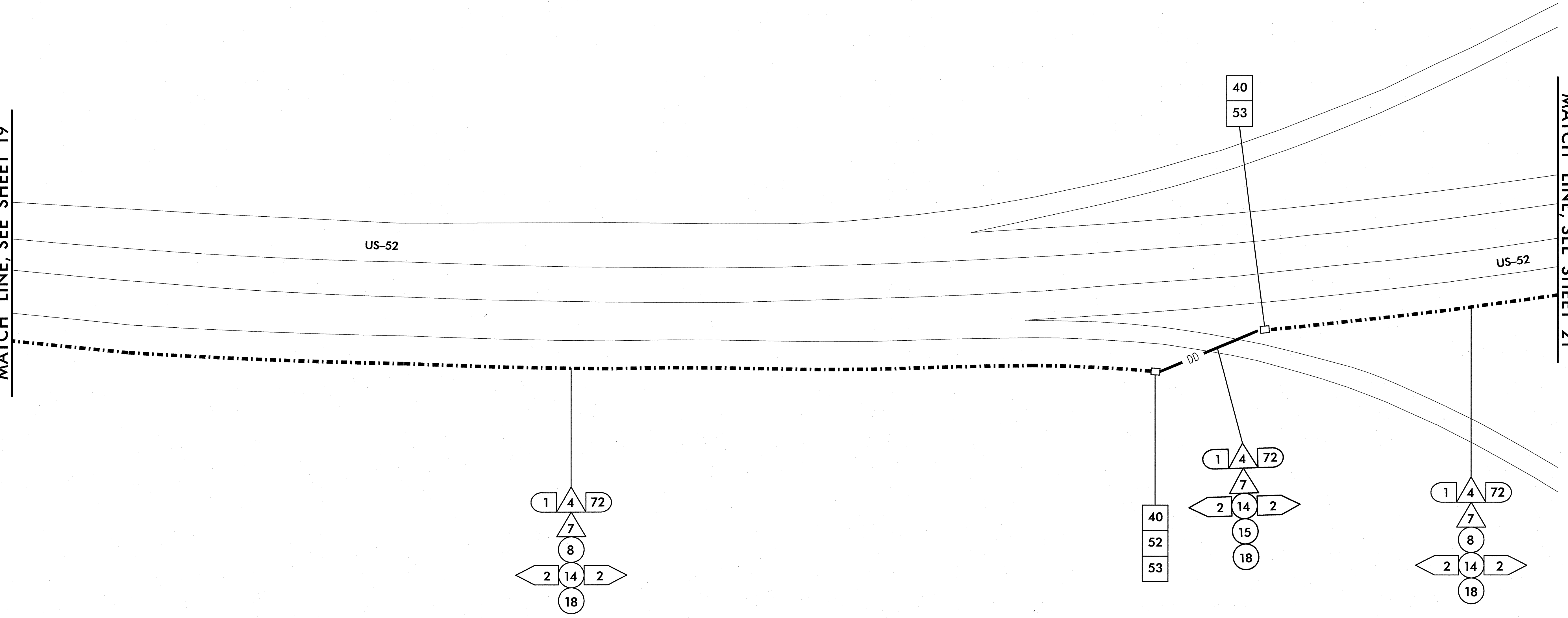

k:\real\proj_its\0103658-us_52_1ts (U-2826B)\plan\sh1 020.dgn
11:46:21 AM Jerry Cross
1/25/2011

PLANS PREPARED IN THE OFFICE OF:

Kimley-Horn and Associates, Inc.
P.O. Box 33068
Raleigh, N.C. 27636-3068
(919) 677-2000
N.C. License # F-0102

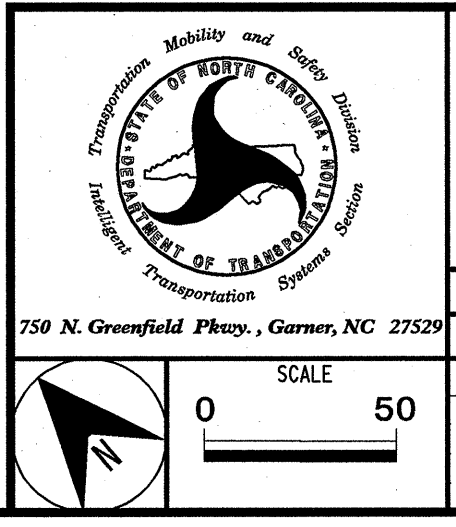

U-2826B	
CABLE ROUTING PLAN SHEET	
DIVISION 9 FORSYTH COUNTY WINSTON SALEM	
PLAN DATE: JANUARY 2011	REVIEWED BY:
PREPARED BY: J. Cross	REVIEWED BY: S. Privette
REVISIONS	INIT. DATE

SEAL

STEPHANIE B. PRIVETTE
1/25/11
DATE

CADD Filename:

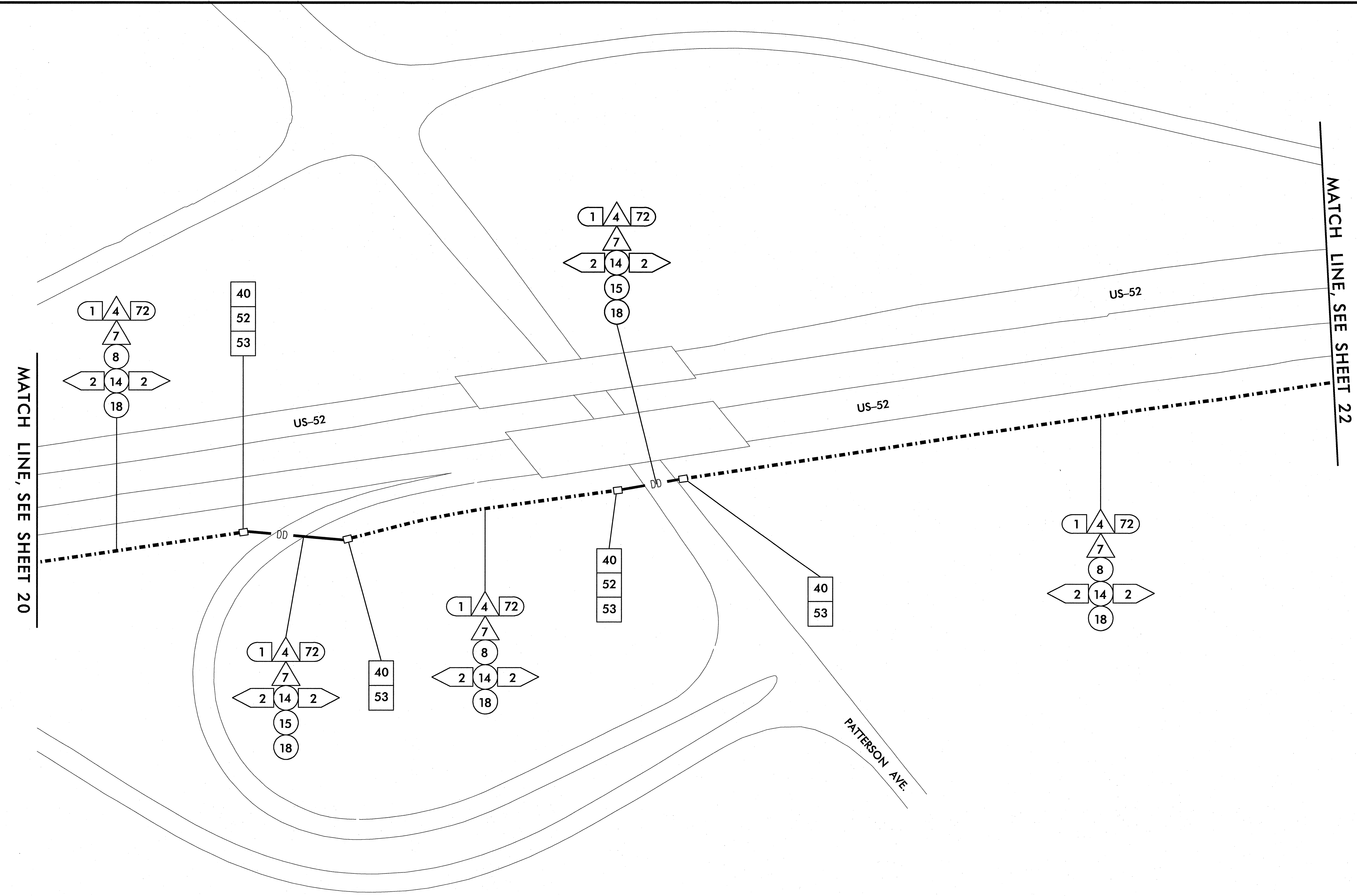

1/25/2011 11:46:23 AM jerry.cross k:\ra1_prio_its\01086158-us_52_its (u-2826B)\plan\sh1 021.dgn

PLANS PREPARED IN THE OFFICE OF:

Kimley-Horn and Associates, Inc.
 P.O. Box 33068
 Raleigh, N.C. 27636-3068
 (919) 677-2000
 N.C. License # F-0102

750 N. Greenfield Pkwy., Garner, NC 27529

U-2826B	
CABLE ROUTING PLAN SHEET	
DIVISION 9 FORSYTH COUNTY WINSTON SALEM	
PLAN DATE: JANUARY 2011	REVIEWED BY:
PREPARED BY: J. Cross	REVIEWED BY: S. Privette
REVISIONS	INIT. DATE

SEAL

SEAL
24432
ENGINEER
STEPHANIE B. PRIVETTE

DATE: 1-25-11
 CADD Filename:

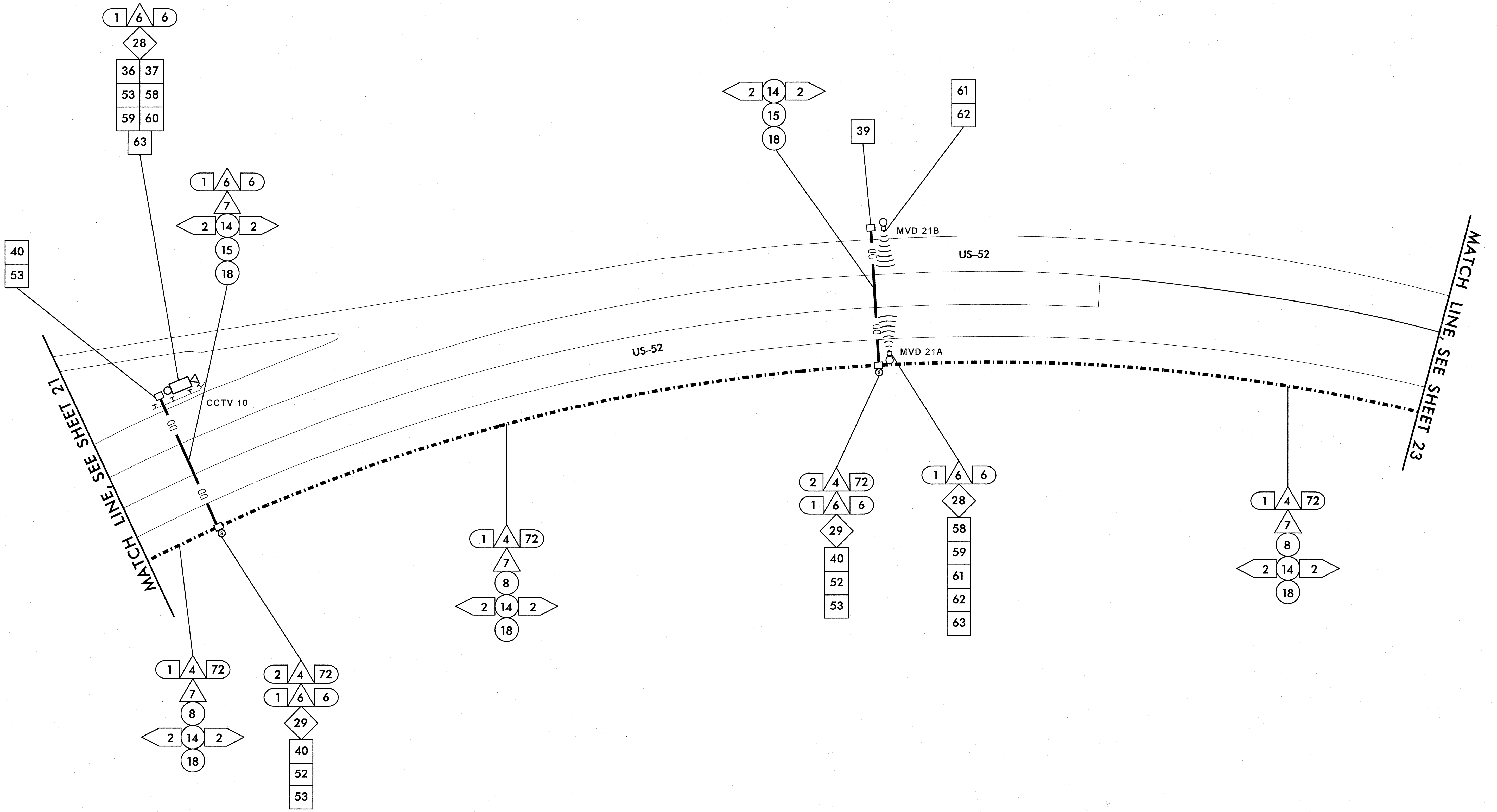

k:\ral\proj\its\01036158-us_52_11s (u-2826b)\plan\shd 022.dgn
11-16:23 AM jerry.cross
1/25/2011

PLANS PREPARED IN THE OFFICE OF:

Kimley-Horn and Associates, Inc.
P.O. Box 33068
Raleigh N.C. 27636-3068
(919) 677-2000
N.C. License # F-0102

750 N. Greenfield Pkwy., Garner, NC 27529
SCALE 0 50

U-2826B			
CABLE ROUTING PLAN SHEET			
DIVISION 9 FORSYTH COUNTY		WINSTON SALEM	
PLAN DATE: JANUARY 2011	PREPARED BY: J. Cross	REVIEWED BY: S. Privette	DATE

SEAL

STEPHANIE B. PRIVETTE
SIGNATURE DATE 1-25-11
CADD Filename:

MATCH LINE, SEE SHEET 22

MATCH LINE, SEE SHEET 24

US-52

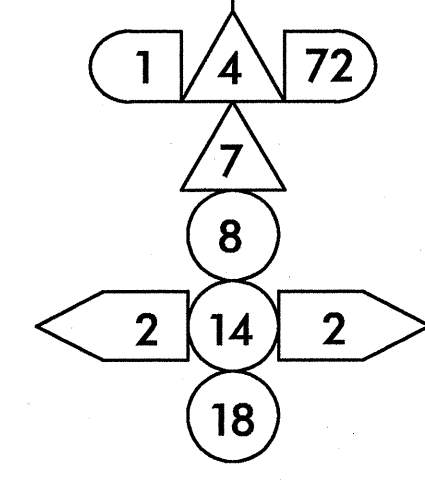
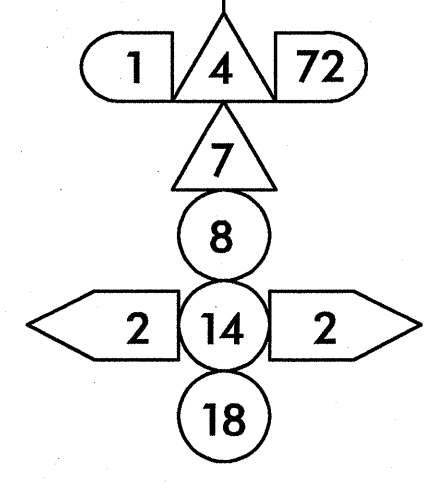

k:\na\proj\its\01036158-us_52_its (U-2826B)\plan\sh1 023.dgn
 11-16-24 AM jerry.cross
 1/25/2011

PLANS PREPARED IN THE OFFICE OF:

Kimley-Horn and Associates, Inc.
 P.O. Box 33068
 Raleigh, N.C. 27636-3068
 (919) 677-2000
 N.C. License # F-0102



U-2826B	
CABLE ROUTING PLAN SHEET	
DIVISION 9 FORSYTH COUNTY WINSTON SALEM	
PLAN DATE: JANUARY 2011	REVIEWED BY:
PREPARED BY: J. Cross	REVIEWED BY: S. Privette
REVISIONS	INIT. DATE

SEAL

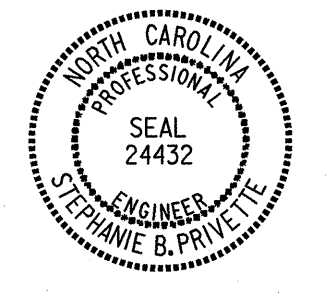

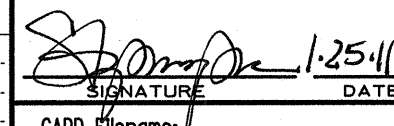
 SIGNATURE DATE 1-25-11
 CADD Filename:

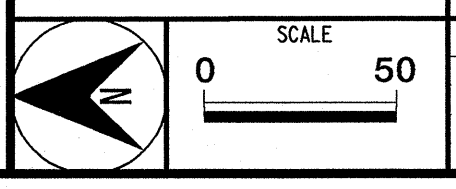

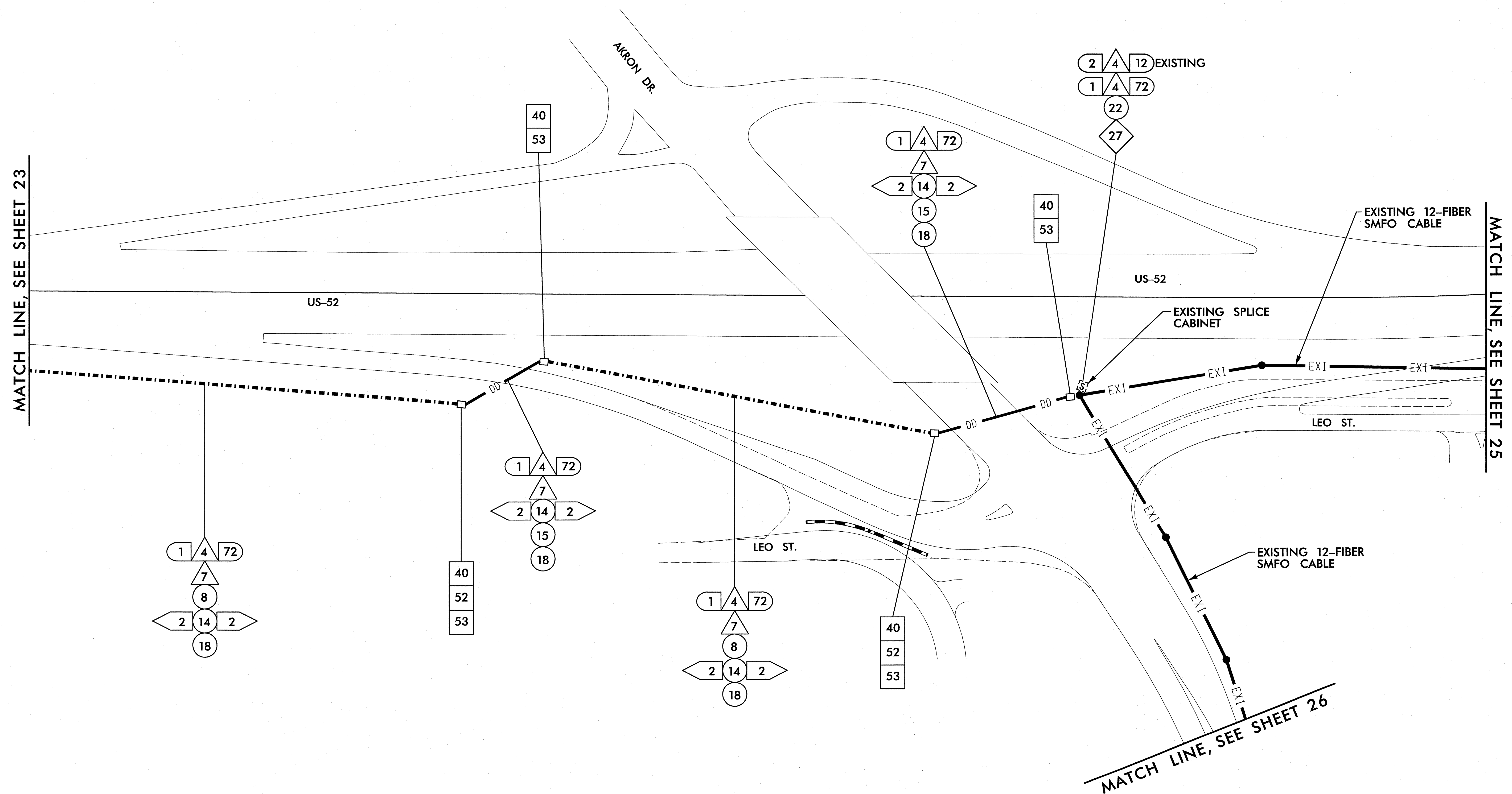

MATCH LINE, SEE SHEET 23

MATCH LINE, SEE SHEET 25

MATCH LINE, SEE SHEET 26

1/25/2011 11:46:25 AM jbrty.cross k:\na1_dna1_its\01080608-us_52_its\U-2826B\plan\Sh1 024.dgn

NOTE:
1. EXISTING AND PROPOSED ROADWAY SHOWN FOR CLARIFICATION.

PLANS PREPARED IN THE OFFICE OF:

Kimley-Horn and Associates, Inc.
P.O. Box 33068
Raleigh, N.C. 27636-3068
(919) 677-2000
N.C. License # F-0102

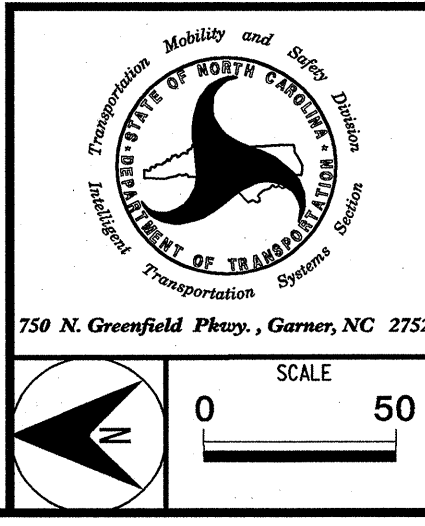

U-2826B	
CABLE ROUTING PLAN SHEET	
DIVISION 9 FORSYTH COUNTY WINSTON SALEM	
PLAN DATE: JANUARY 2011	REVIEWED BY:
PREPARED BY: J. Cross	REVIEWED BY: S. Privette
REVISIONS	INIT. DATE

SEAL

STEPHANIE B. PRIVETTE
1/25/11
DATE

CADD Filenames

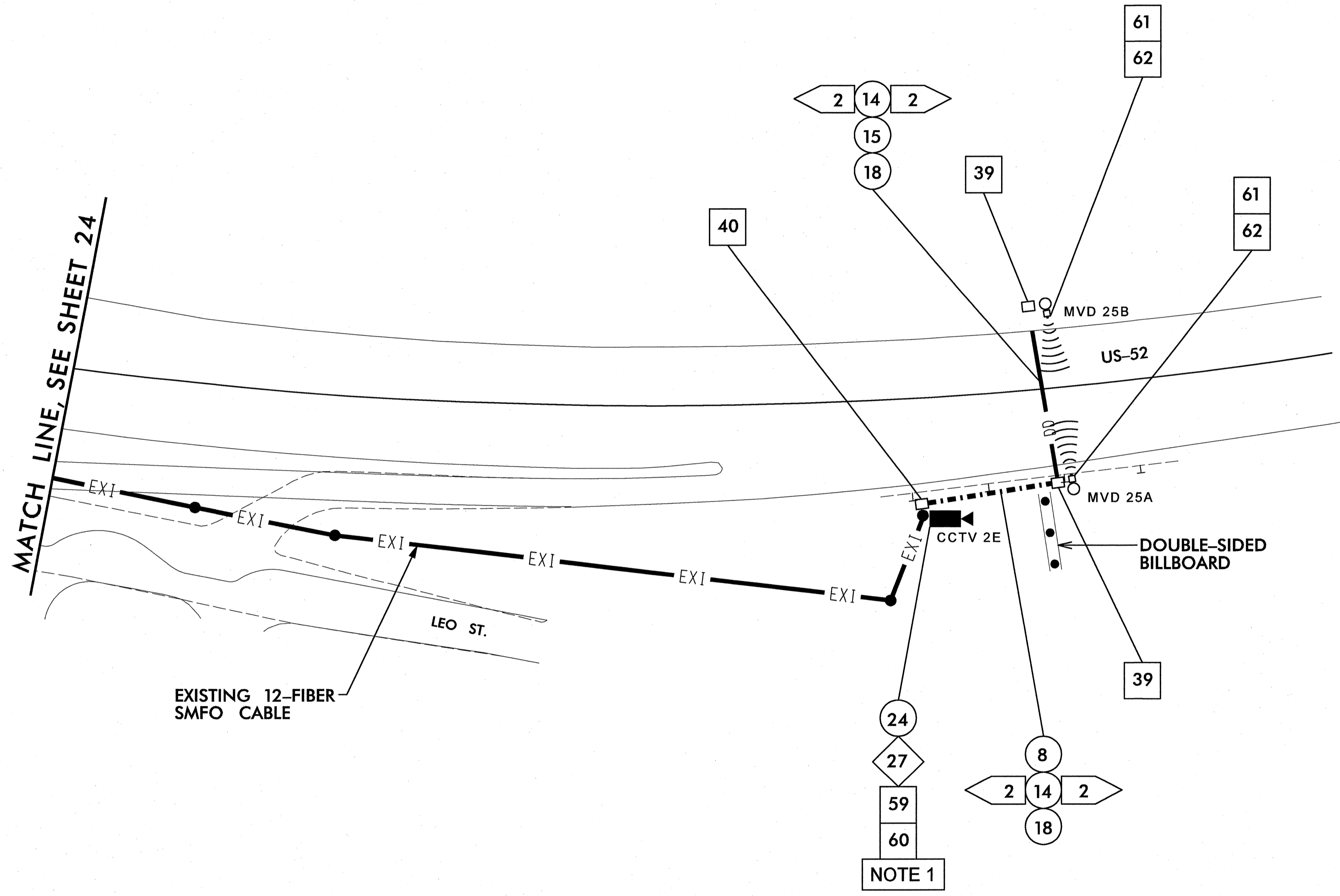

k:\real\proj_its\01056158-us_52_11s (U-2826B)\plan\sh1 025.dgn
 11:46:28 AM jerry.cross
 1/25/2011

NOTE:
 1. INSTALL MVD EQUIPMENT IN EXISTING CCTV CABINET.
 2. EXISTING AND PROPOSED ROADWAY SHOWN FOR CLARIFICATION.

PLANS PREPARED IN THE OFFICE OF:

Kimley-Horn and Associates, Inc.
 P.O. Box 33068
 Raleigh, N.C. 27636-3068
 (919) 677-2000
 N.C. License # F-0102

750 N. Greenfield Pkwy., Garner, NC 27529
 SCALE 0 50

U-2826B	
CABLE ROUTING PLAN SHEET	
DIVISION 9 FORSYTH COUNTY WINSTON SALEM	
PLAN DATE: JANUARY 2011	REVIEWED BY:
PREPARED BY: J. Cross	REVIEWED BY: S. Privette
REVISIONS	INIT. DATE

SEAL

SIGNATURE: *Stephanie B. Privette*
 DATE: 1-25-11
 CADD Filename:

MATCH LINE, SEE SHEET 24

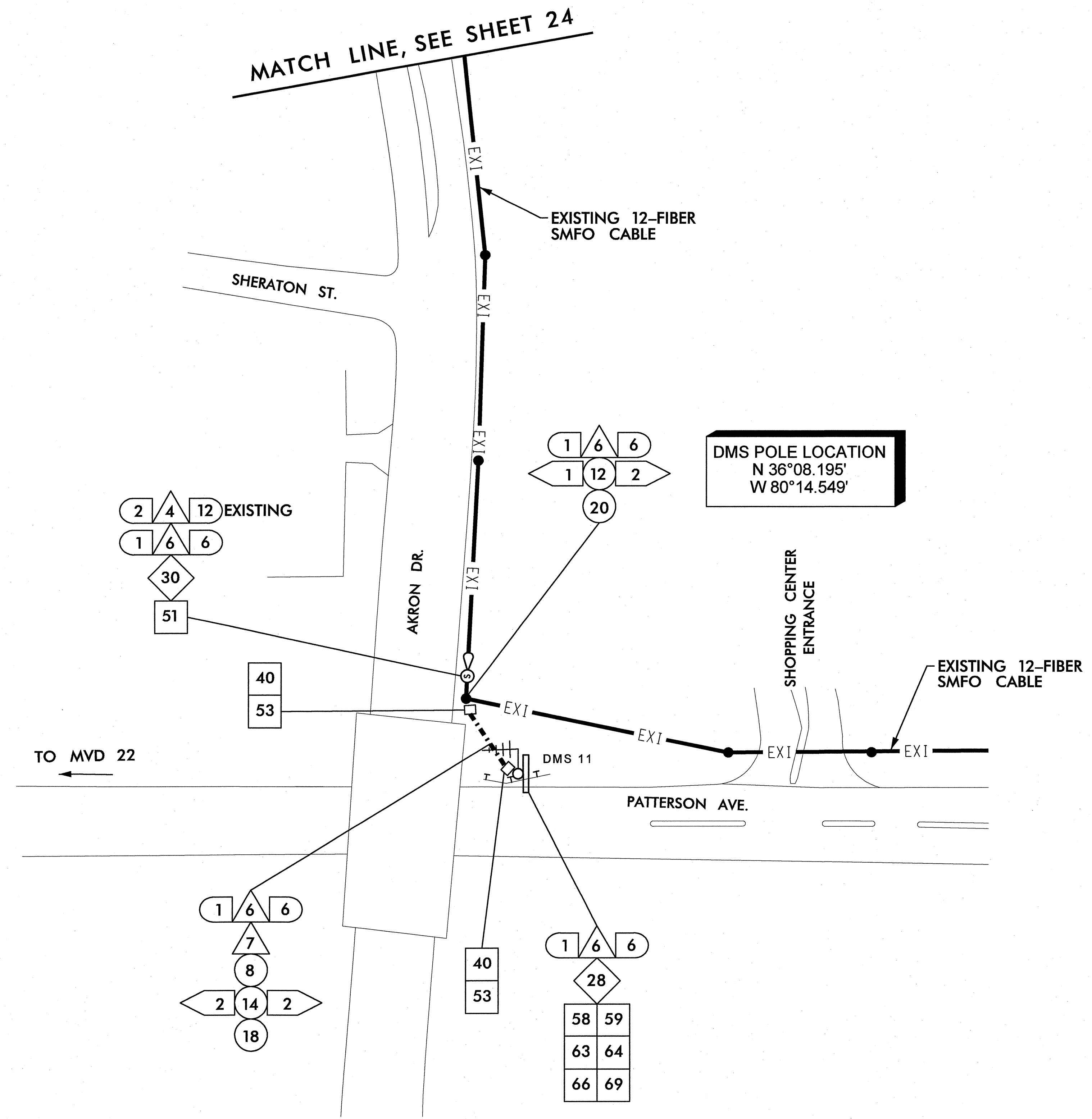

1/25/2011 11:46:27 AM jerry.cross k:\real_proj_its\01036158-us_52_11s (U-2826B)\plan\shf 026.dgn

PLANS PREPARED IN THE OFFICE OF:

Kimley-Horn and Associates, Inc.
 P.O. Box 33068
 Raleigh, N.C. 27636-3068
 (919) 677-2000
 N.C. License # F-0102

750 N. Greenfield Pkwy., Garner, NC 27529

U-2826B	
CABLE ROUTING PLAN SHEET	
DIVISION 9 FORSYTH COUNTY WINSTON SALEM	
PLAN DATE: JANUARY 2011	REVIEWED BY:
PREPARED BY: J. Cross	REVIEWED BY: S. Privette
SCALE: 0 50	REVISIONS
INIT.	DATE

SEAL

SEAL 24432
 ENGINEER
 STEPHANIE B. PRIVETTE

Stephanie B. Privette 1-25-11
 SIGNATURE DATE

CADD Filename: _____

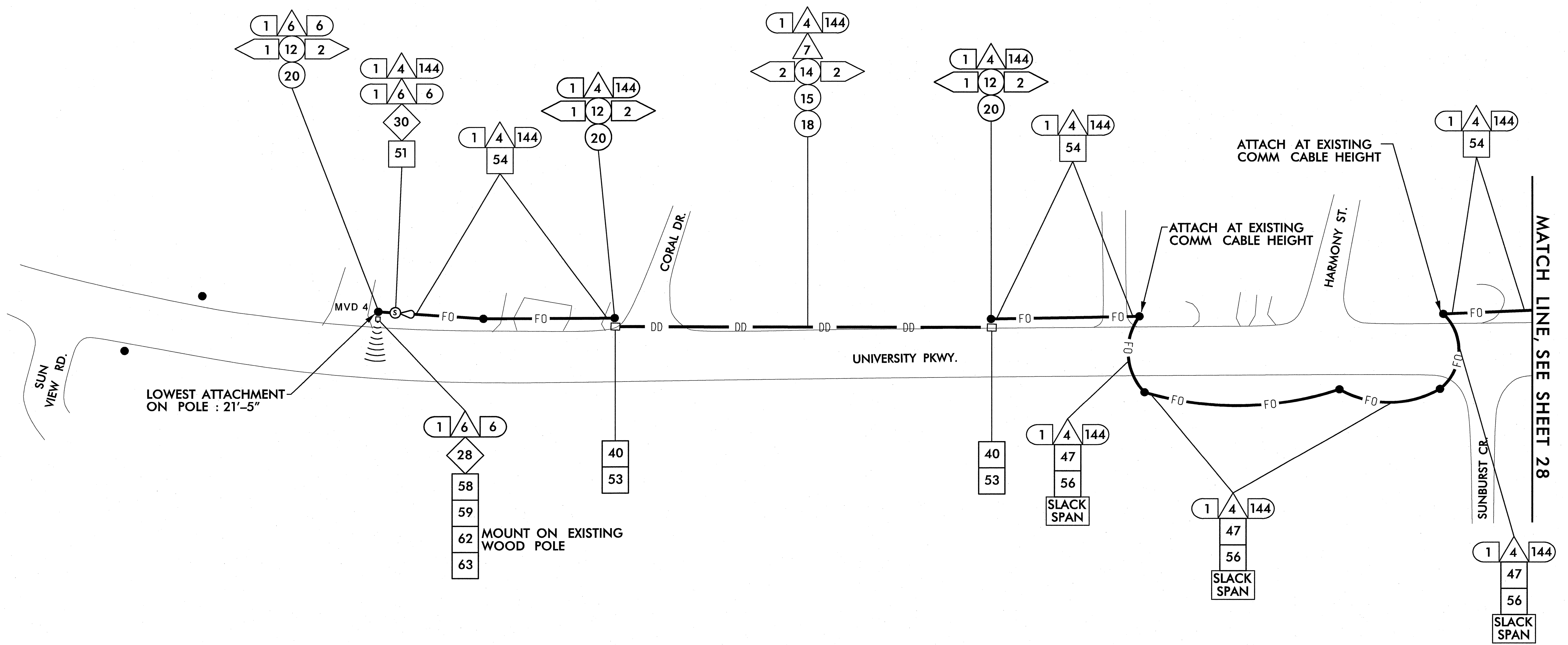

NOTE:
ATTACH 40" BELOW POWER, FRONT SIDE
OF POLE, UNLESS OTHERWISE NOTED

1/25/2011 11:46:29 AM jerry.cross k:\rd\proj\its\01036158-us_52_its (U-2826B)\plan\shd_027.dgn

PLANS PREPARED IN THE OFFICE OF:

Kimley-Horn and Associates, Inc.
 P.O. Box 33068
 Raleigh, N.C. 27636-3068
 (919) 677-2000
 N.C. License # F-0102

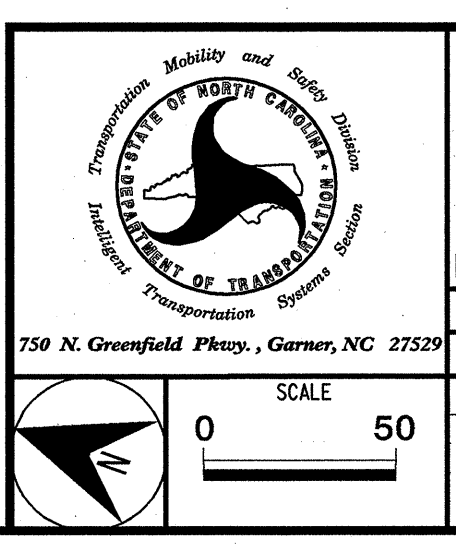

U-2826B	
CABLE ROUTING PLAN SHEET	
DIVISION 9 FORSYTH COUNTY WINSTON SALEM	
PLAN DATE: JANUARY 2011	REVIEWED BY:
PREPARED BY: J. Cross	REVIEWED BY: S. Privette
SCALE	0 50
REVISIONS	INIT. DATE

SEAL

STEPHANIE B. PRIVETTE
 ENGINEER
 STATE OF NORTH CAROLINA
 LICENSE NO. 24432

Signature: *[Handwritten Signature]* DATE: 1-25-11
 CADD Filename:

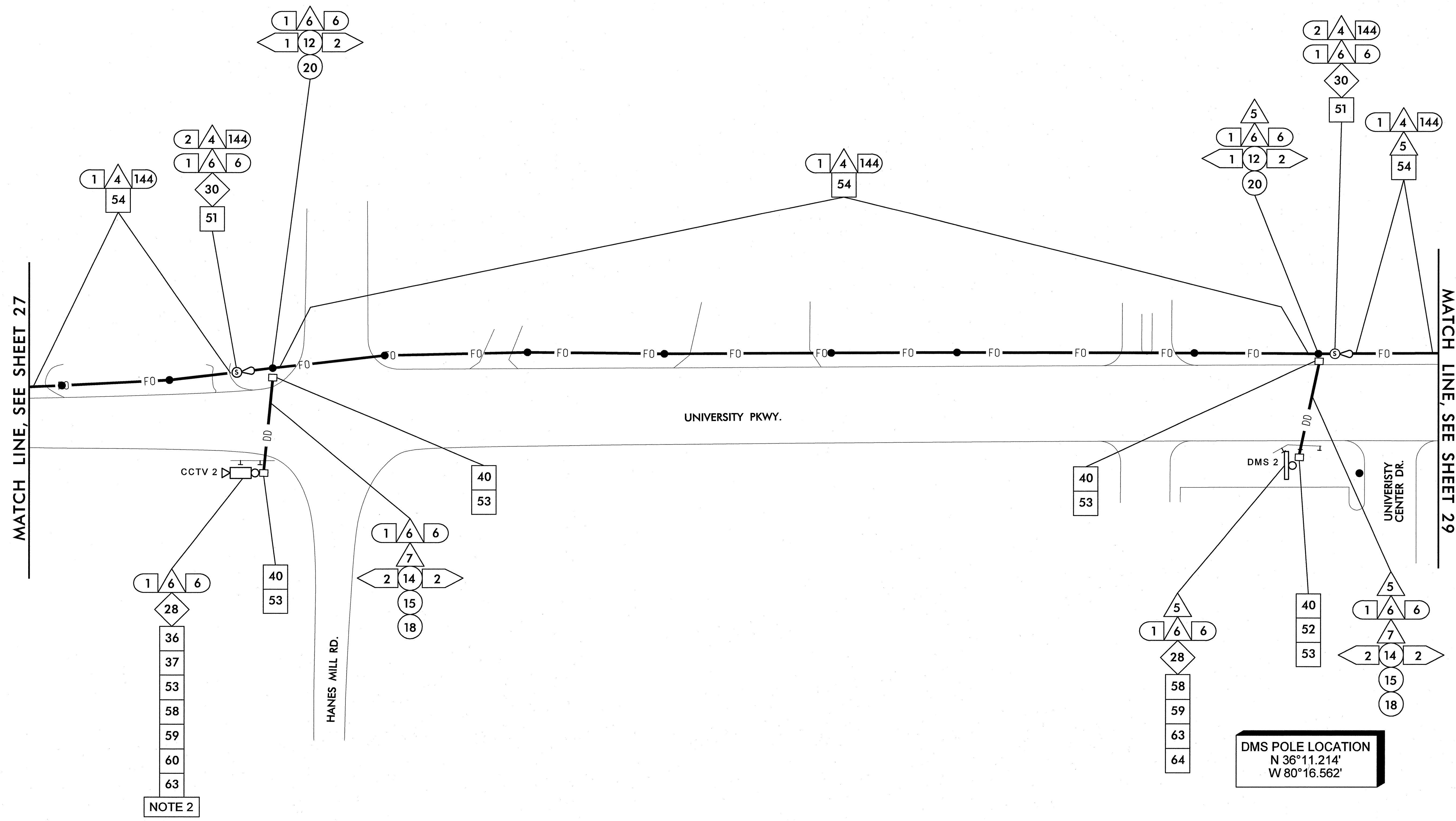

DMS POLE LOCATION
N 36°11.214'
W 80°16.562'

k:\ra1\proj\its\1028198-us 52.its (u-2826b)\plan\sheet 028.dgn

1/25/2011 11:46:29 AM jerry.gross

NOTES:

1. ATTACH 40" BELOW POWER, FRONT SIDE OF POLE, UNLESS OTHERWISE NOTED.
2. LOCATE CCTV POLE TO AVOID RELOCATION UPON FUTURE WIDENING OF HANES MILL ROAD.

PLANS PREPARED IN THE OFFICE OF:
Kimley-Horn and Associates, Inc.
P.O. Box 33068
Raleigh N.C. 27636-3068
(919) 677-2000
N.C. License # F-0102

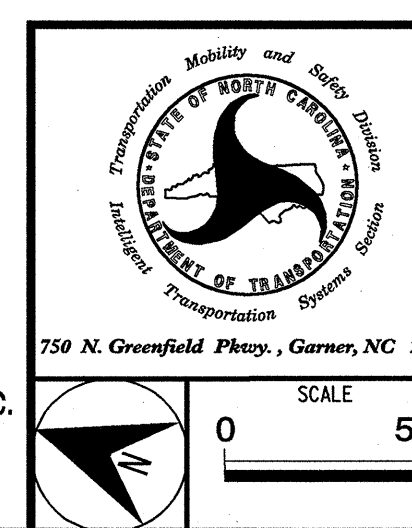

U-2826B	
CABLE ROUTING PLAN SHEET	
DIVISION 9	FORSYTH COUNTY
Winston Salem	
PLAN DATE: JANUARY 2011	REVIEWED BY:
PREPARED BY: J. Cross	REVIEWED BY: S. Privette
SCALE	DATE
0 50	

SEAL
NORTH CAROLINA PROFESSIONAL ENGINEER SEAL 24432
STEPHANIE B. PRIVETTE
DATE 1-25-11

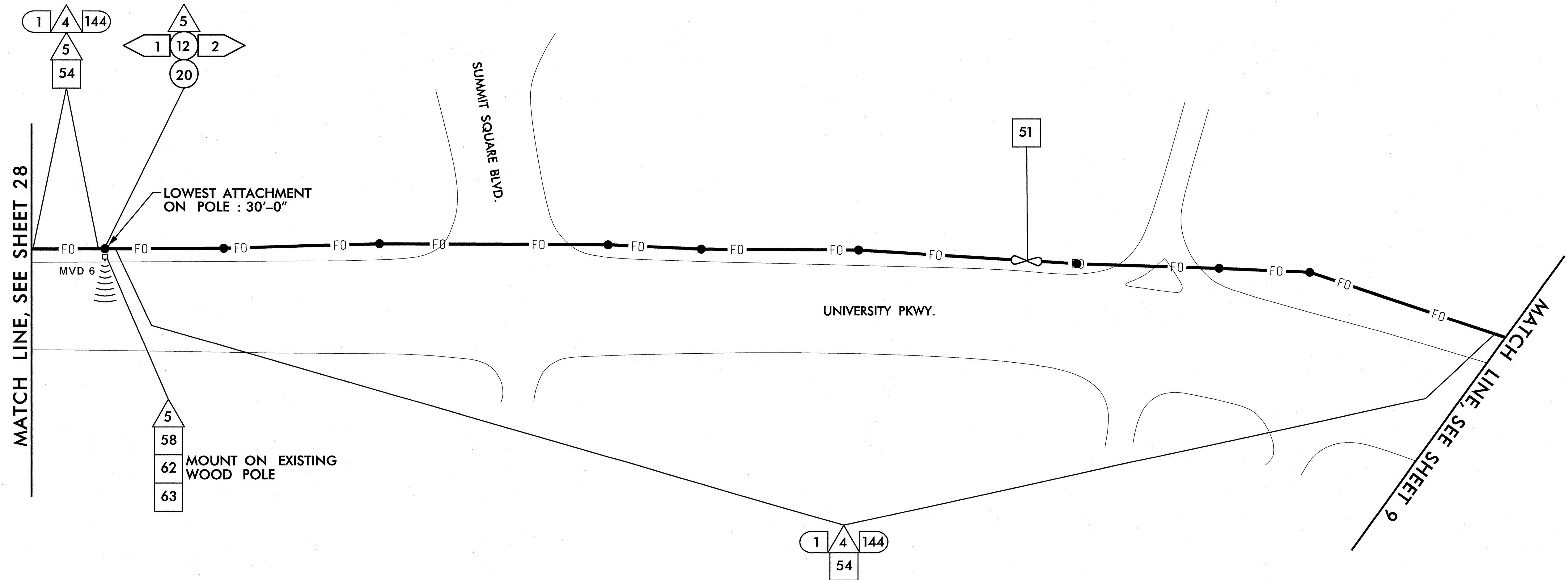

NOTE:
ATTACH 40" BELOW POWER, FRONT SIDE
OF POLE, UNLESS OTHERWISE NOTED

1/25/2011 11:46:30 AM jerty.cross k:\ra1_pno_its\011036158-us_52_1ts (U-2826B)\plan\SH 029.dgn

PLANS PREPARED IN THE OFFICE OF:

Kimley-Horn and Associates, Inc.
 P.O. Box 33068
 Raleigh, N.C. 27636-3068
 (919) 677-2000
 N.C. License # F-0102

750 N. Greenfield Pkwy., Garner, NC 27529
 SCALE: 0 50

U-2826B	
CABLE ROUTING PLAN SHEET	
DIVISION 9 FORSYTH COUNTY WINSTON SALEM	
PLAN DATE: JANUARY 2011	REVIEWED BY:
PREPARED BY: J. Cross	REVIEWED BY: S. Privette
REVISIONS	INIT. DATE

SEAL

 SIGNATURE: DATE: 1.26.11
 CAD: Phenomenon

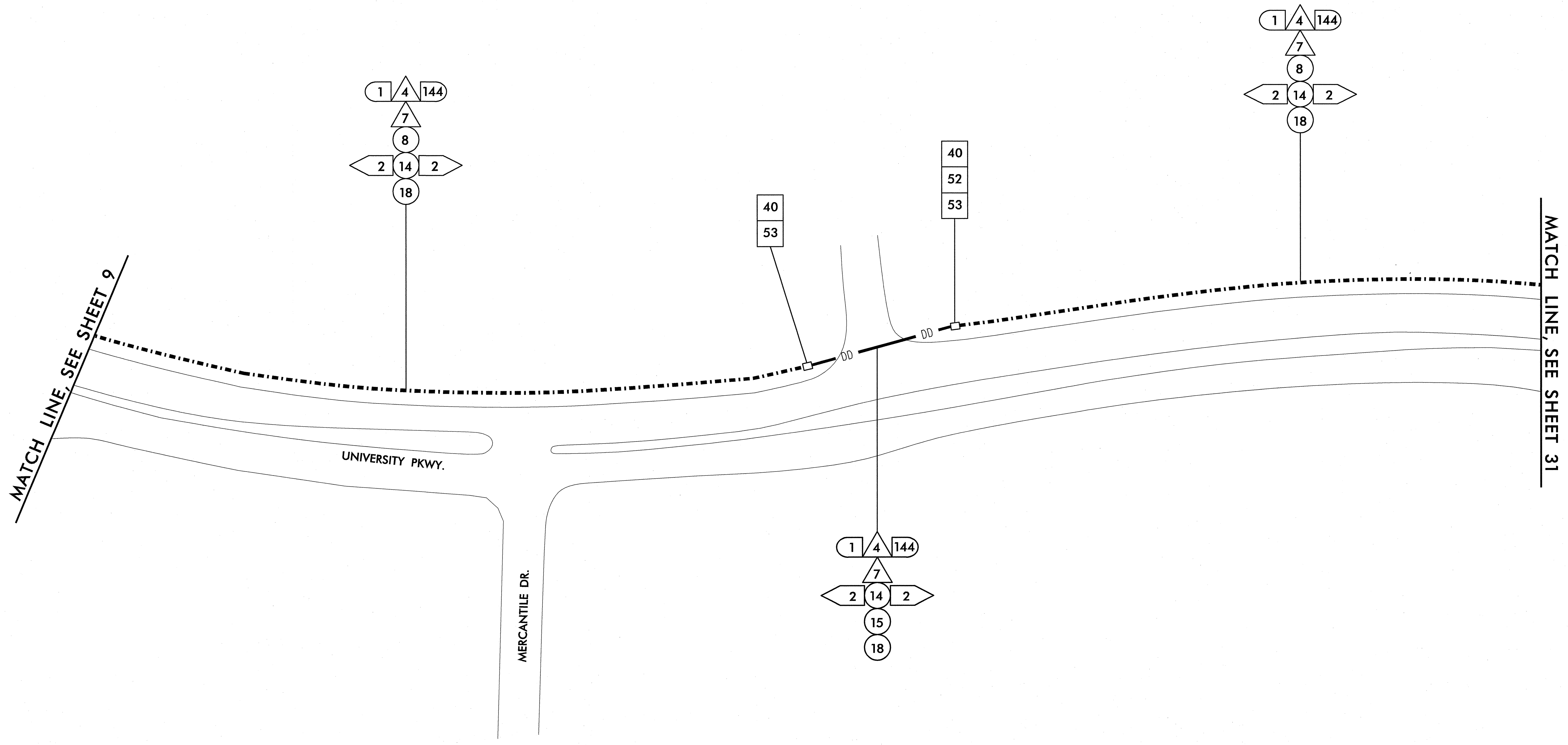

MATCH LINE, SEE SHEET 9

MATCH LINE, SEE SHEET 31

UNIVERSITY PKWY.

MERCANTILE DR.

k:\real_proo_its\0108658-us_52_Its (U-2826B)\plan\Shit 030.dgn
11:46:37 AM jerry.cross
1/25/2011

PLANS PREPARED IN THE OFFICE OF:

Kimley-Horn and Associates, Inc.
P.O. Box 33068
Raleigh N.C. 27636-3068
(919) 677-2000
N.C. License # F-0102

750 N. Greenfield Pkwy., Garner, NC 27529

U-2826B	
CABLE ROUTING PLAN SHEET	
DIVISION 9 FORSYTH COUNTY WINSTON SALEM	
PLAN DATE: JANUARY 2011	REVIEWED BY:
PREPARED BY: J. Cross	REVIEWED BY: S. Privette
REVISIONS	INIT. DATE

SEAL

STEPHANIE B. PRIVETTE
ENGINEER
SEAL 24432

1/25/11
SIGNATURE DATE

CADD Filename:

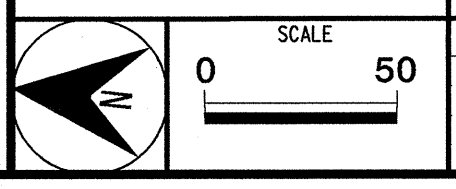

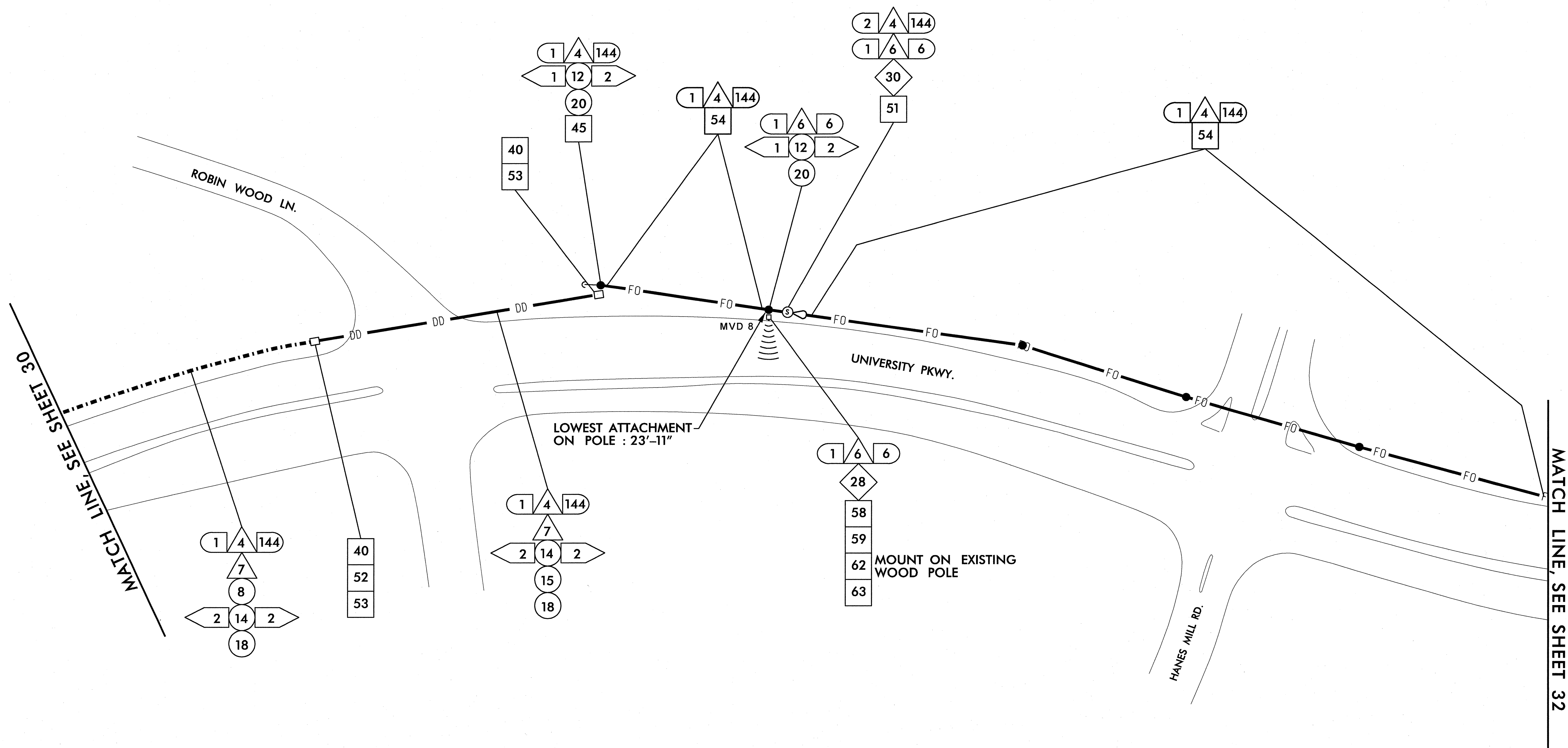

NOTE:
ATTACH 40" BELOW POWER, FRONT SIDE OF POLE, UNLESS OTHERWISE NOTED

1/25/2011 11:46:32 AM jerry.cross k:\rad_tproj_its\01066158-us_52_its (U-2826B)\plan\sh1 031.dgn

PLANS PREPARED IN THE OFFICE OF:

Kimley-Horn and Associates, Inc.
 P.O. Box 33068
 Raleigh, N.C. 27636-3068
 (919) 677-2000
 N.C. License # F-0102

750 N. Greenfield Pkwy., Garner, NC 27529

U-2826B	
CABLE ROUTING PLAN SHEET	
DIVISION 9 FORSYTH COUNTY WINSTON SALEM	
PLAN DATE: JANUARY 2011	REVIEWED BY:
PREPARED BY: J. Cross	REVIEWED BY: S. Privette
REVISIONS	INIT. DATE

SEAL

STEPHANIE B. PRIVETTE
 ENGINEER
 No. 24432

1-25-11
 DATE

CADD Filenames

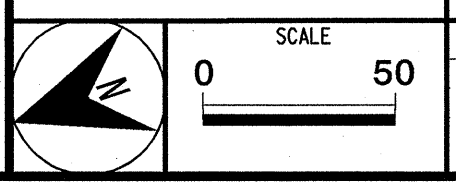

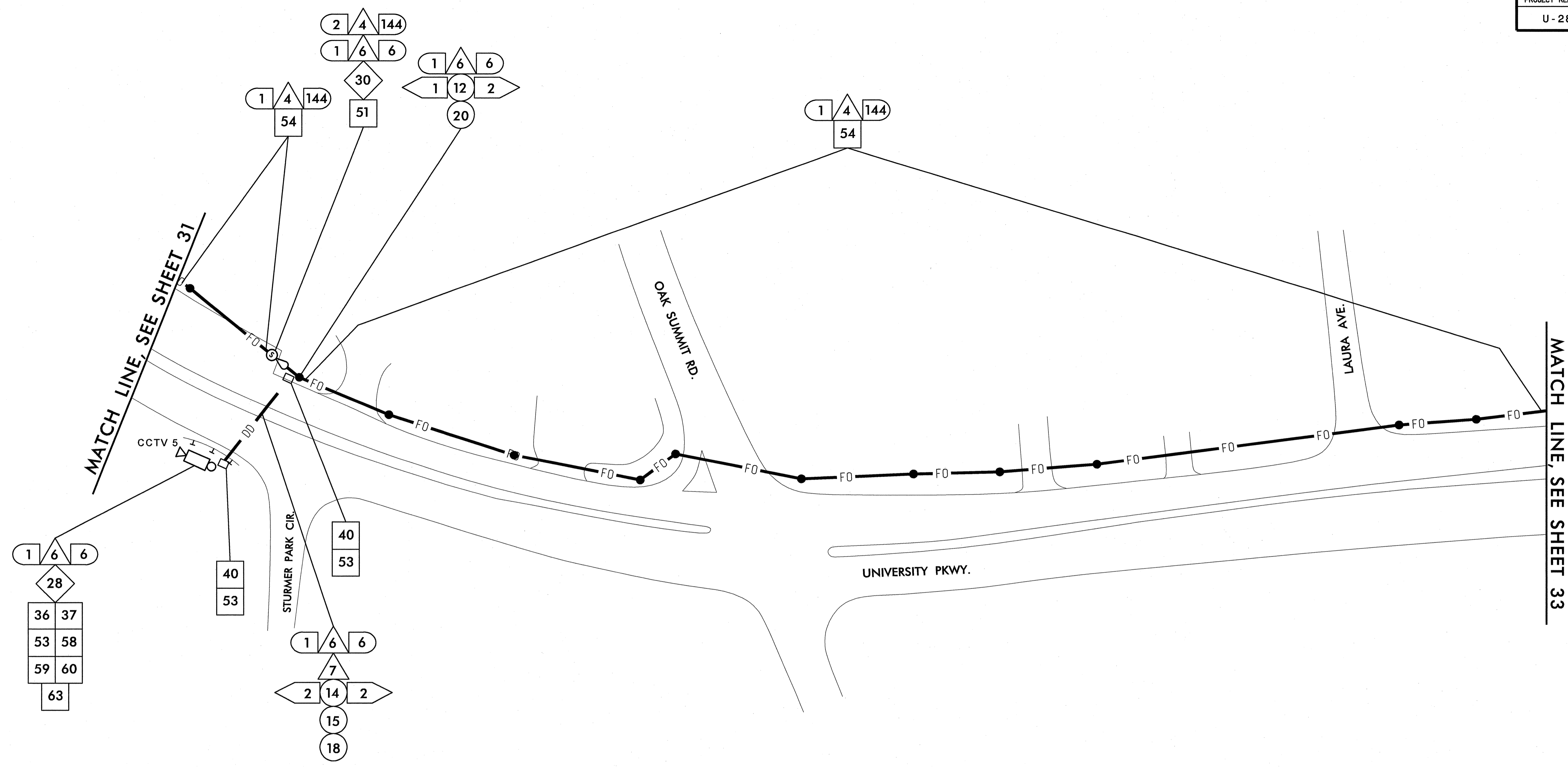

NOTE:
ATTACH 40" BELOW POWER, FRONT SIDE
OF POLE, UNLESS OTHERWISE NOTED

1/25/2011 11:46:33 AM jerry.cross k:\cal_tproj_its\01086158-us 52_its (u-2826B)\plan\sh1 032.dgn

PLANS PREPARED IN THE OFFICE OF:

Kimley-Horn and Associates, Inc.
 P.O. Box 33068
 Raleigh N.C. 27636-3068
 (919) 677-2000
 N.C. License # F-0102

750 N. Greenfield Place, Garner, NC 27529

U-2826B	
CABLE ROUTING PLAN SHEET	
DIVISION 9 FORSYTH COUNTY WINSTON SALEM	
PLAN DATE: JANUARY 2011	REVIEWED BY:
PREPARED BY: J. Cross	REVIEWED BY: S. Privette
REVISIONS	INIT. DATE

SEAL

SIGNATURE DATE 1-25-11
 CADD Filenames

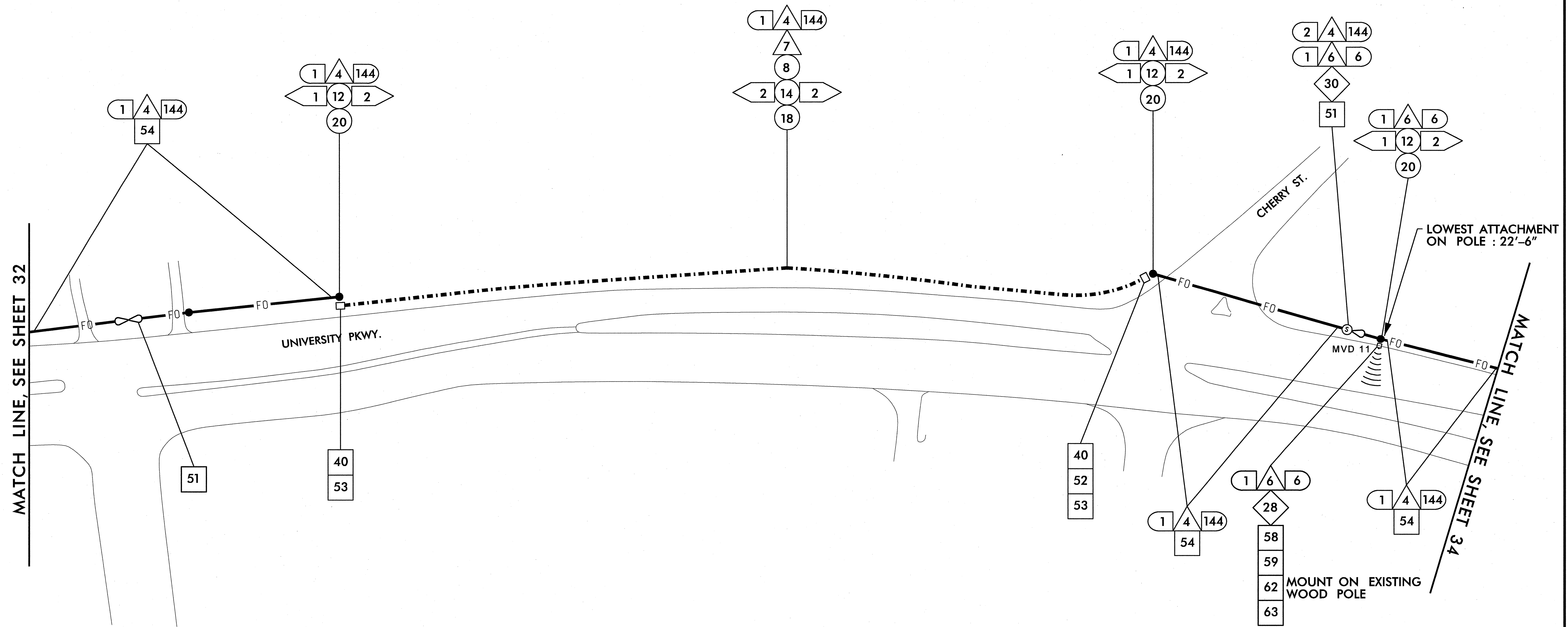

NOTE:
ATTACH 40" BELOW POWER, FRONT SIDE
OF POLE, UNLESS OTHERWISE NOTED

k:\ra1_tproj_its\0108858-us_52_its (u-2826B)\plan\shet 033.dgn
 11-4634 AW jerry.cross
 1/25/2011

PLANS PREPARED IN THE OFFICE OF:

Kimley-Horn and Associates, Inc.
 P.O. Box 33068
 Raleigh, N.C. 27636-3068
 (919) 677-2000
 N.C. License # F-0102

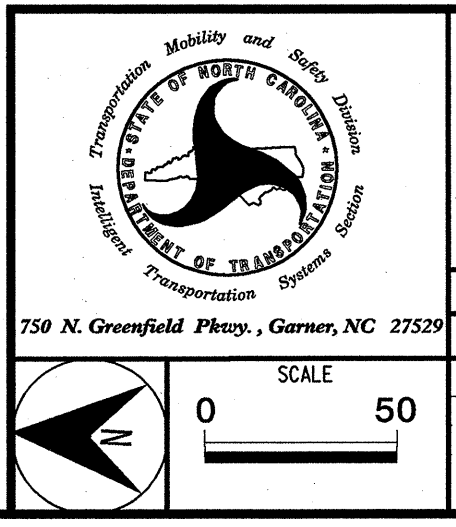

U-2826B	
CABLE ROUTING PLAN SHEET	
DIVISION 9 FORSYTH COUNTY WINSTON SALEM	
PLAN DATE: JANUARY 2011	REVIEWED BY:
PREPARED BY: J. Cross	REVIEWED BY: S. Privette
SCALE: 0 50	REVISIONS
	INIT. DATE

SEAL

STEPHANIE B. PRIVETTE
 ENGINEER
 SEAL 24432
 SIGNATURE DATE 1-25-11
 CADD Filename

MATCH LINE, SEE SHEET 33

MATCH LINE, SEE SHEET 35

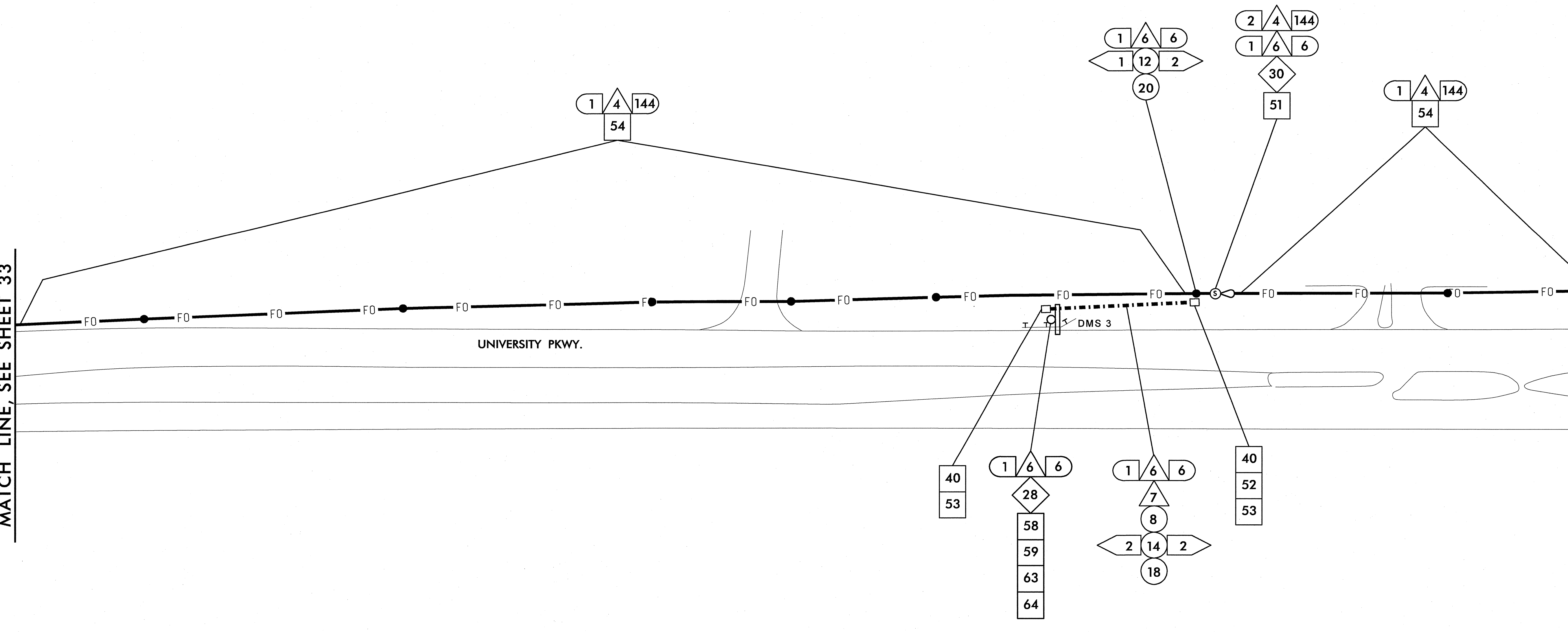

DMS POLE LOCATION
 N 36°09.792'
 W 80°16.649'

NOTE:
 ATTACH 40" BELOW POWER, FRONT SIDE
 OF POLE, UNLESS OTHERWISE NOTED

1/25/2011 11:46:35 AM jerry.cross k:\real\proj_its\01038158-us_52_its (U-2826B)\plan\sh34.dgn

PLANS PREPARED IN THE OFFICE OF:

Kimley-Horn and Associates, Inc.
 P.O. Box 33068
 Raleigh, N.C. 27636-3068
 (919) 677-2000
 N.C. License # F-0102

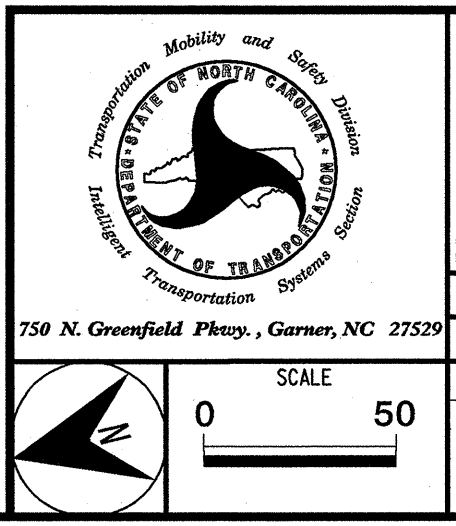

U-2826B	
CABLE ROUTING PLAN SHEET	
DIVISION 9 FORSYTH COUNTY WINSTON SALEM	
PLAN DATE: JANUARY 2011	REVIEWED BY:
PREPARED BY: J. Cross	REVIEWED BY: S. Privette
REVISIONS	INIT. DATE

SEAL

 SIGNATURE: *Stephanie B. Privette* 1-25-11
 DATE

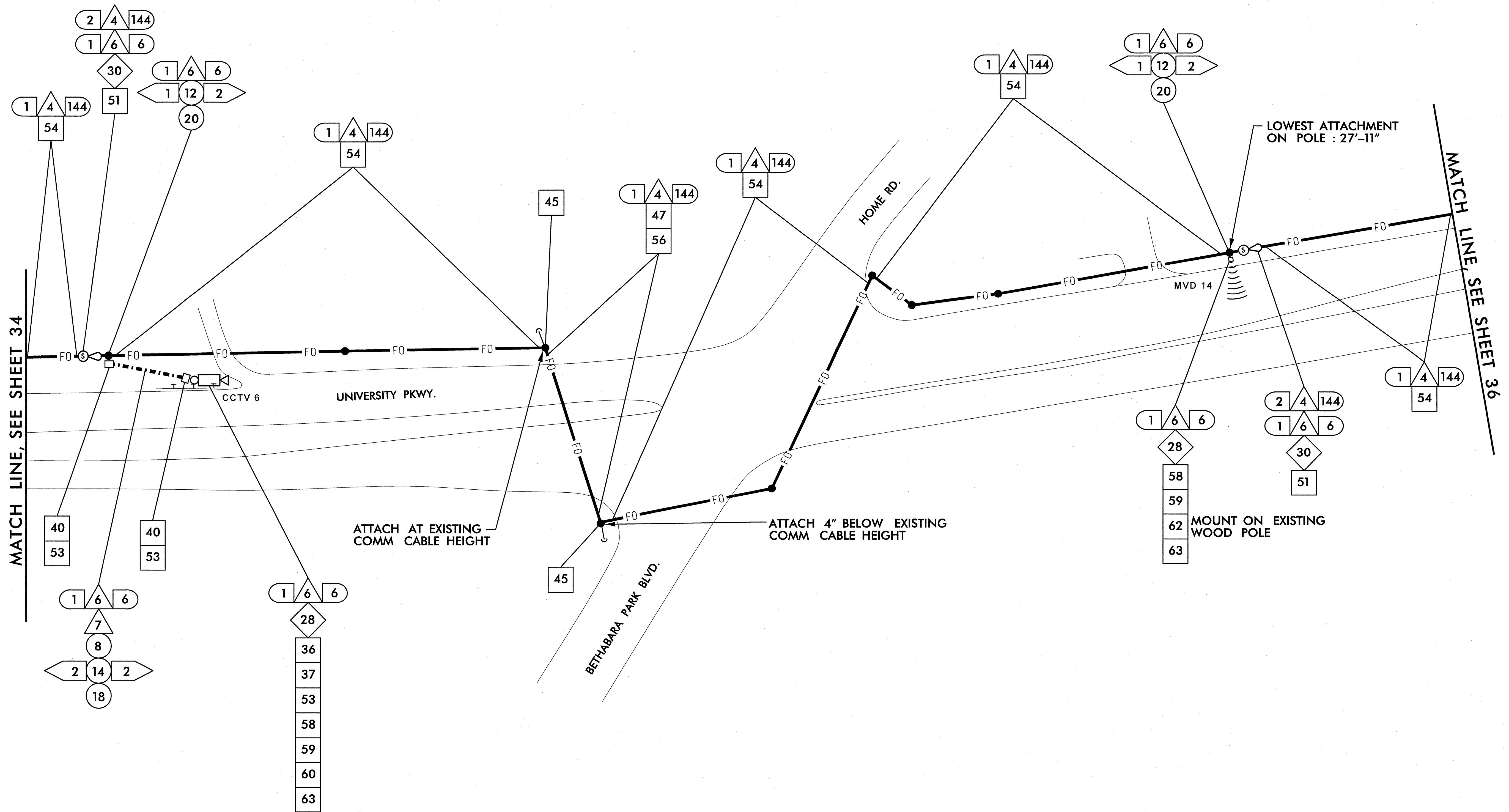

NOTE:
ATTACH 40" FRONT SIDE OF POLE BELOW
POWER UNLESS OTHERWISE NOTED

1/25/2011 11:46:36 AM jerry.gross k:\rel_tproj_its\01086158-us 52.its (U-2826B)\plan\sh 005.dgn

PLANS PREPARED IN THE OFFICE OF:

Kimley-Horn and Associates, Inc.
P.O. Box 33068
Raleigh N.C. 27636-3068
(919) 677-2000
N.C. License # F-0102

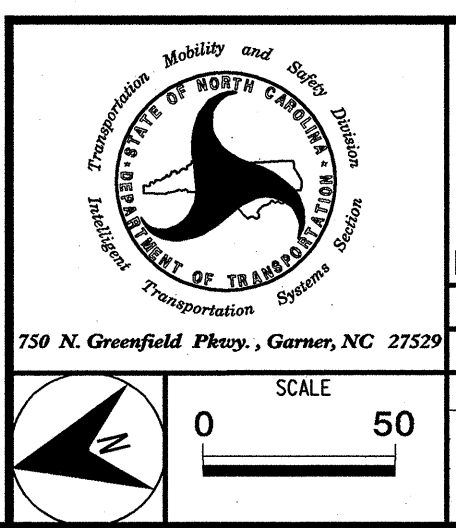

U-2826B	
CABLE ROUTING PLAN SHEET	
DIVISION 9 FORSYTH COUNTY WINSTON SALEM	
PLAN DATE: JANUARY 2011	REVIEWED BY:
PREPARED BY: J. Cross	REVIEWED BY: S. Privette
REVISIONS	INIT. DATE

SEAL

STEPHANIE B. PRIVETTE
ENGINEER
SEAL 24432

Signature: *Stephanie B. Privette* 1/25/11
DATE

CADD Filename:

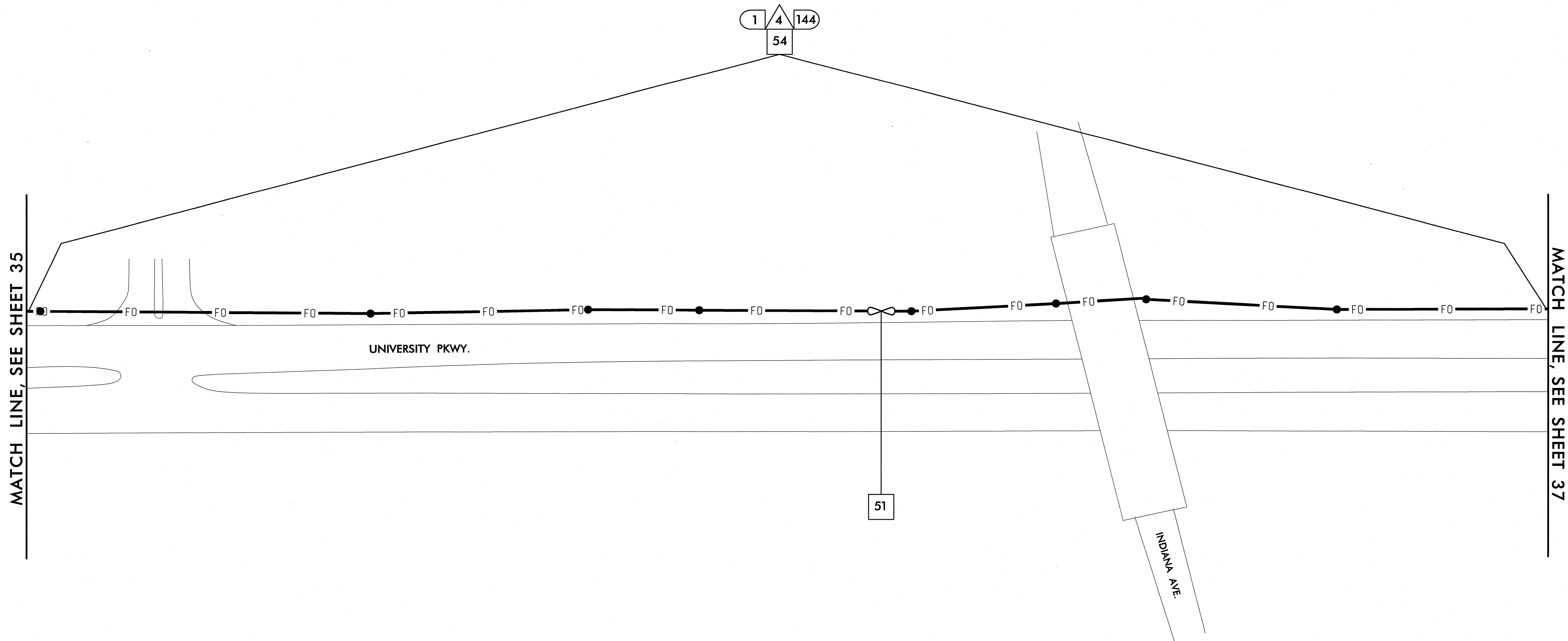

NOTE:
ATTACH 40" BELOW POWER, FRONT SIDE
OF POLE, UNLESS OTHERWISE NOTED

1/25/2011 11:46:37 AM jerry.cross k:\val_tproj_its\01086158-us 52_its (u-2826b)\plan\sh 336.dgn

PLANS PREPARED IN THE OFFICE OF:

Kimley-Horn and Associates, Inc.
P.O. Box 33068
Raleigh N.C. 27636-3068
(919) 677-2000
N.C. License # F-0102



U-2826B	
CABLE ROUTING PLAN SHEET	
DIVISION 9 FORSYTH COUNTY WINSTON SALEM	
PLAN DATE: JANUARY 2011	REVIEWED BY:
PREPARED BY: J. Cross	REVIEWED BY: S. Privette
REVISIONS	INIT. DATE

SEAL

STEPHANIE B. PRIVETTE
ENGINEER
SEAL 24432

Stephanie B. Privette
SIGNATURE
1-25-11
DATE

CADD Filename:

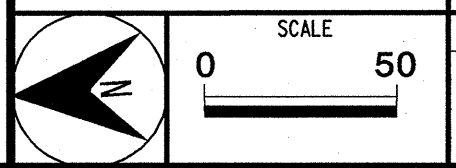

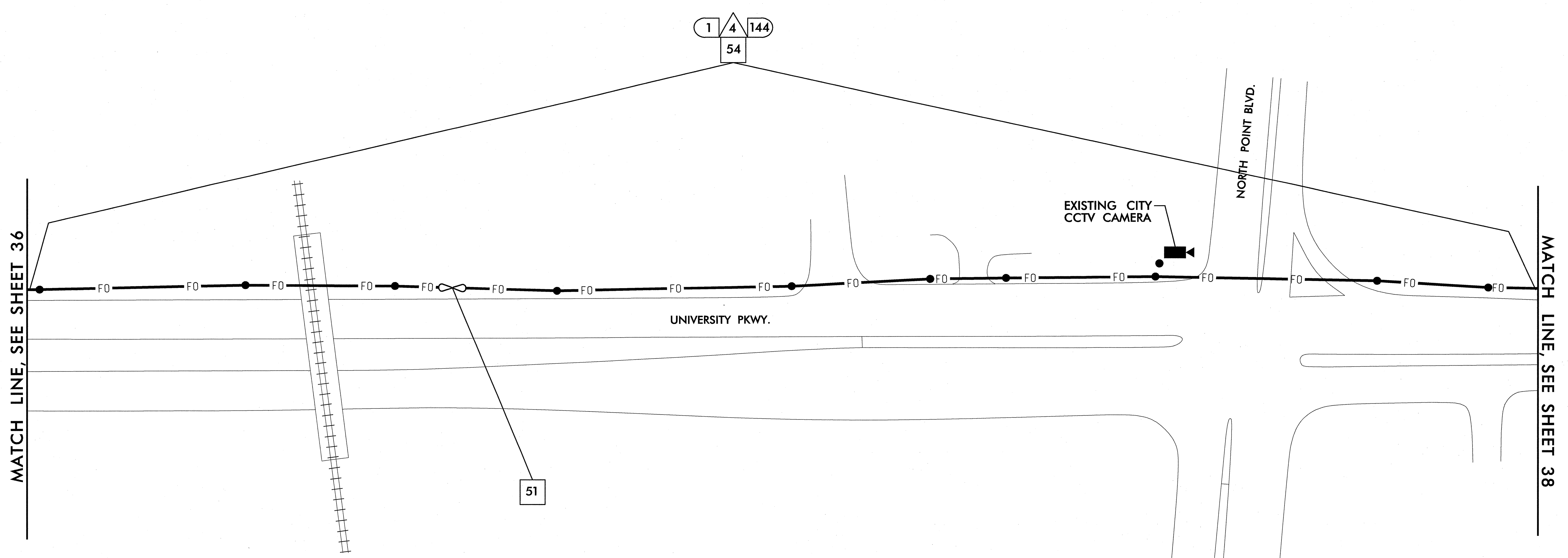

NOTE:
ATTACH 40" BELOW POWER, FRONT SIDE
OF POLE, UNLESS OTHERWISE NOTED

1/25/2011 11:46:38 AM jerry.cross k:\val_tproj_its\01086158-us 52_its (u-2826b)\plan\sh1 037.dgn

PLANS PREPARED IN THE OFFICE OF:

Kimley-Horn and Associates, Inc.
 P.O. Box 33068
 Raleigh N.C. 27636-3068
 (919) 677-2000
 N.C. License # F-0102

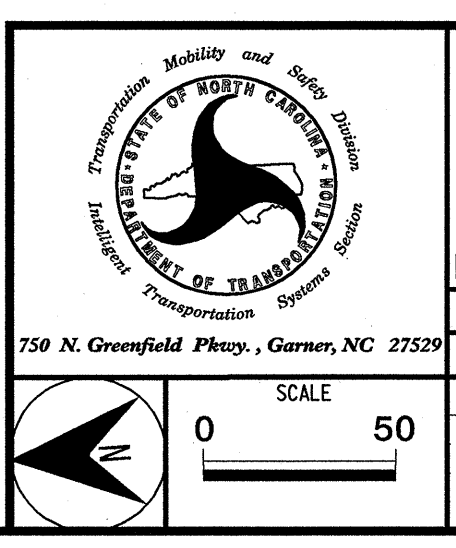

U-2826B	
CABLE ROUTING PLAN SHEET	
DIVISION 9 FORSYTH COUNTY WINSTON SALEM	
PLAN DATE: JANUARY 2011	REVIEWED BY:
PREPARED BY: J. Cross	REVIEWED BY: S. Privette
SCALE	REVISIONS
0 50	INIT. DATE

SEAL

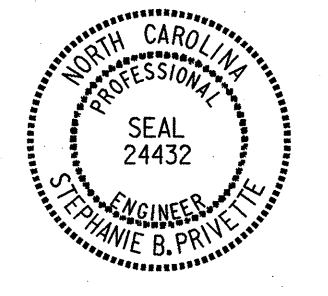

 SIGNATURE DATE 1-25-11
 CADD Filename:

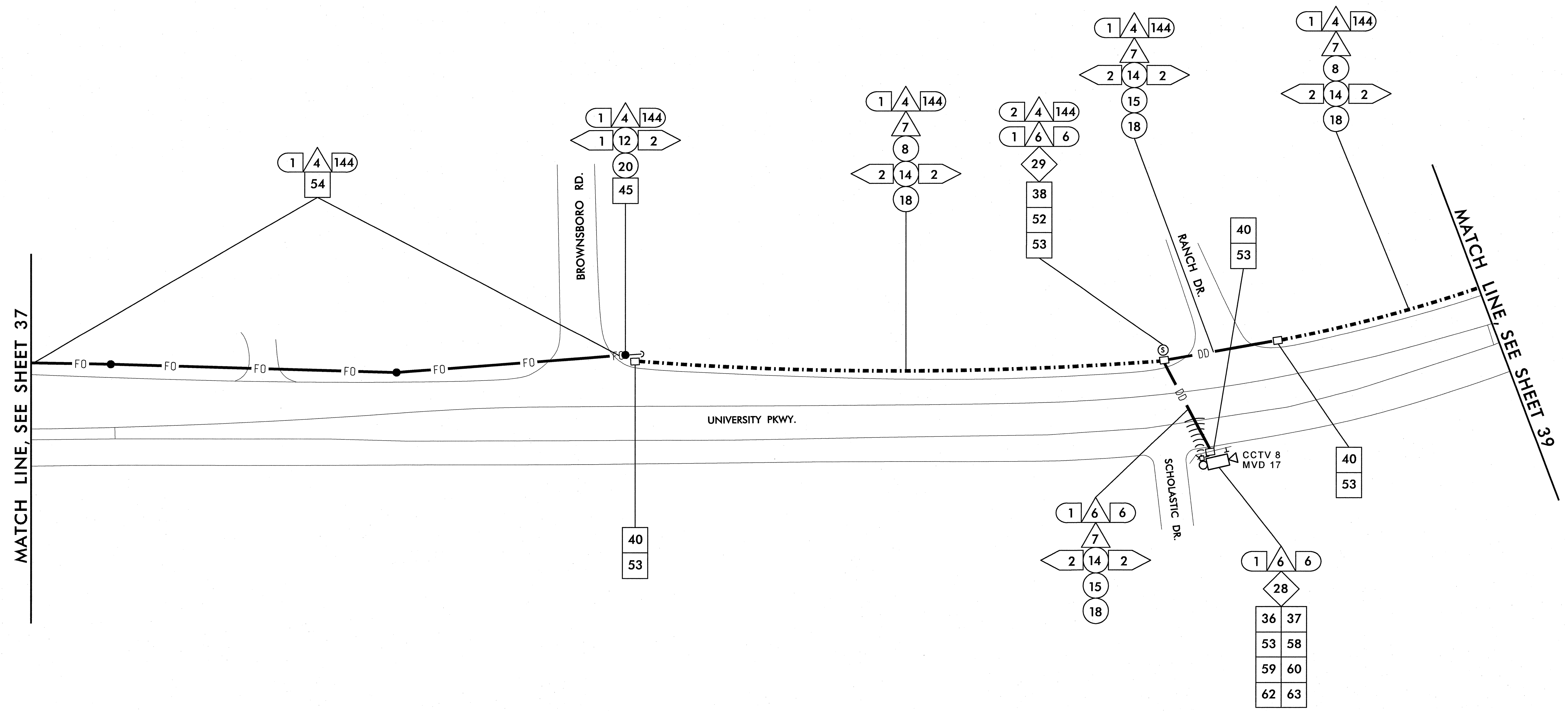

MATCH LINE, SEE SHEET 37

MATCH LINE SEE SHEET 39

NOTE:
ATTACH 40" BELOW POWER, FRONT SIDE
OF POLE, UNLESS OTHERWISE NOTED

1/25/2011 11:46:39 AM jerry.cross k:\rd_tproj_its\01086158-us 52_its (U-2826B)\plan\sh 038.dgn

PLANS PREPARED IN THE OFFICE OF:
Kimley-Horn and Associates, Inc.
P.O. Box 33068
Raleigh, N.C. 27636-3068
(919) 677-2000
N.C. License # F-0102

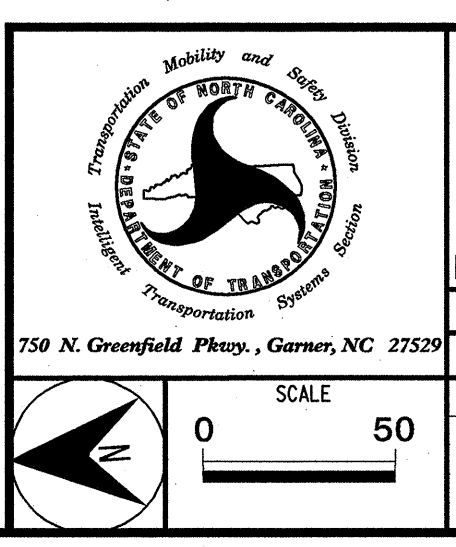

U-2826B	
CABLE ROUTING PLAN SHEET	
DIVISION 9 FORSYTH COUNTY WINSTON SALEM	
PLAN DATE: JANUARY 2011	REVIEWED BY:
PREPARED BY: J. Cross	REVIEWED BY: S. Privette
SCALE	REVISIONS
0 50	INIT. DATE

SEAL

SEAL
24432
STEPHANIE B. PRIVETTE
ENGINEER

Stephanie B. Privette 1-25-11
SIGNATURE DATE
CADD Filename:

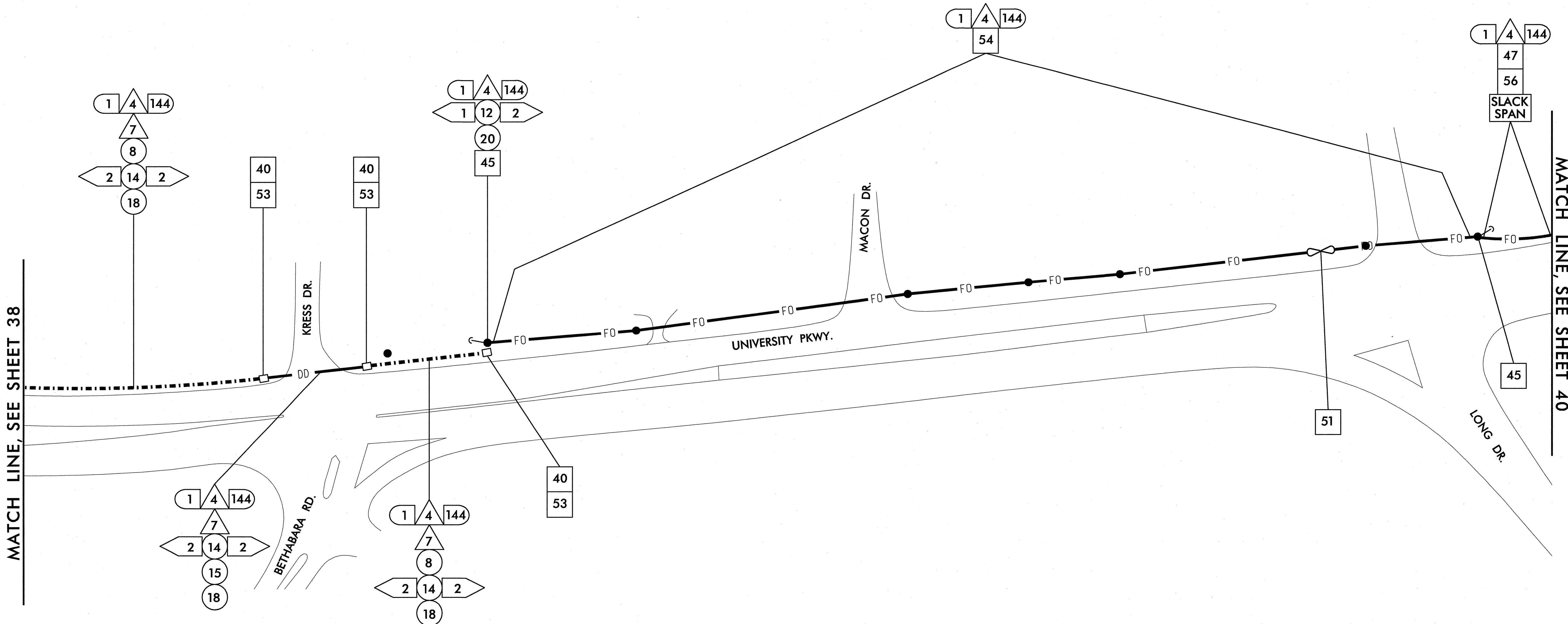

NOTE:
ATTACH 40" BELOW POWER, FRONT SIDE
OF POLE, UNLESS OTHERWISE NOTED

k:\real_tproj_its\01056158-us 52_its (u-2826B)\plan\sh 039.dgn
 1/25/2011 11:46:40 AM jerry.cross

PLANS PREPARED IN
THE OFFICE OF:

**Kimley-Horn
and Associates, Inc.**
P.O. Box 33068
Raleigh N.C. 27636-3068
(919) 677-2000
N.C. License # F-0102

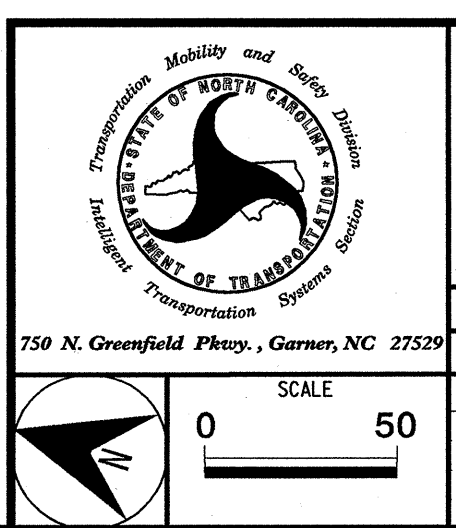

U-2826B	
CABLE ROUTING PLAN SHEET	
DIVISION 9 FORSYTH COUNTY WINSTON SALEM	
PLAN DATE: JANUARY 2011	REVIEWED BY:
PREPARED BY: J. Cross	REVIEWED BY: S. Privette
REVISIONS	INIT. DATE

SEAL

SIGNATURE DATE 1/25/11
 CADD Filename

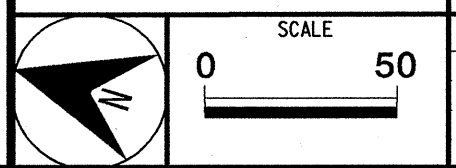

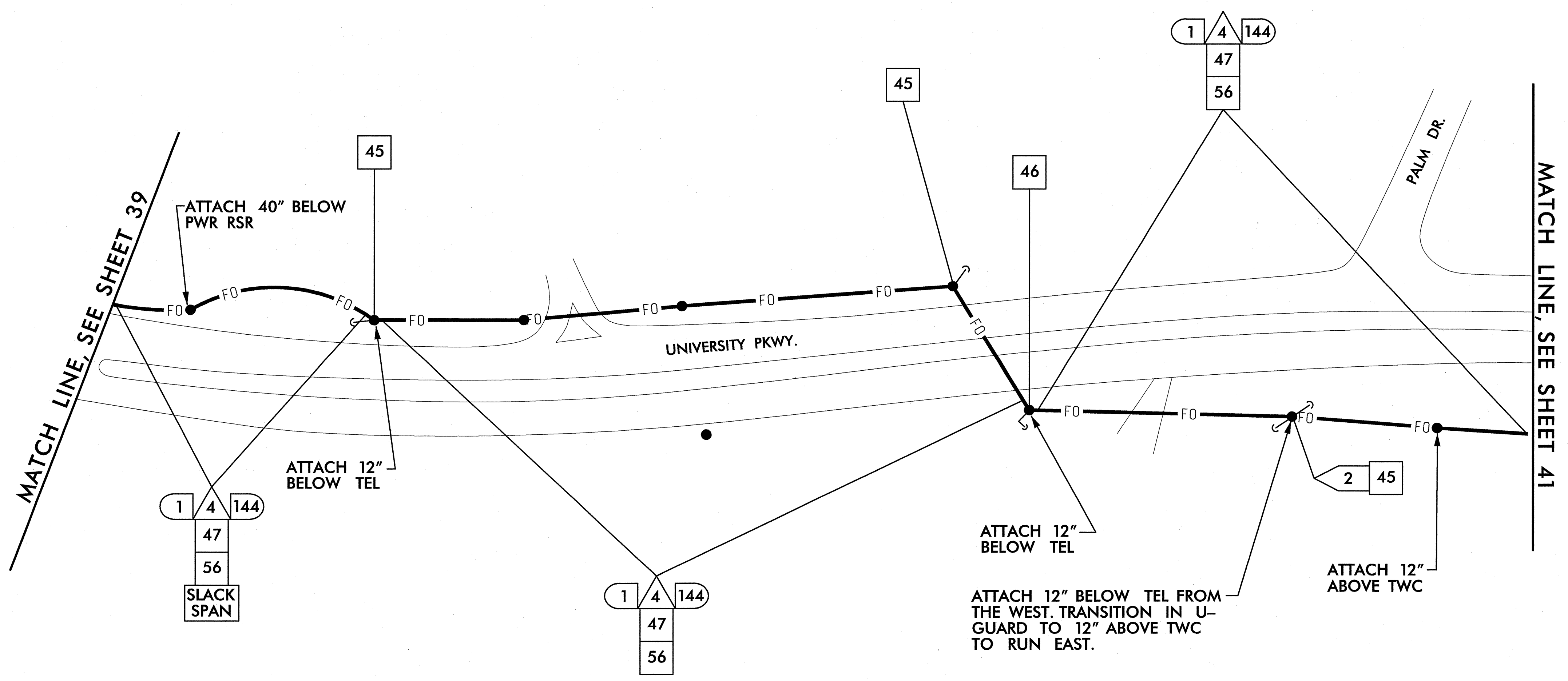

NOTE:
ATTACH 40" BELOW POWER, FRONT SIDE OF POLE, UNLESS OTHERWISE NOTED

1/25/2011 11:46:41 AM jerry.cross k:\real\proj\its\01086158-us_02_11s (U-2826B)\plan\sh1 040.dgn

PLANS PREPARED IN THE OFFICE OF:

Kimley-Horn and Associates, Inc.
 P.O. Box 33068
 Raleigh, N.C. 27636-3068
 (919) 677-2000
 N.C. License # F-0102

750 N. Greenfield Pkwy., Garner, NC 27529

U-2826B	
CABLE ROUTING PLAN SHEET	
DIVISION 9 FORSYTH COUNTY WINSTON SALEM	
PLAN DATE: JANUARY 2011	REVIEWED BY:
PREPARED BY: J. Cross	REVIEWED BY: S. Privette
SCALE	0 50
REVISIONS	INIT. DATE

SEAL

STEPHANIE B. PRIVETTE
 ENGINEER
 No. 24432

SIGNATURE: *[Signature]* DATE: 1/25/11

CADD Filename:

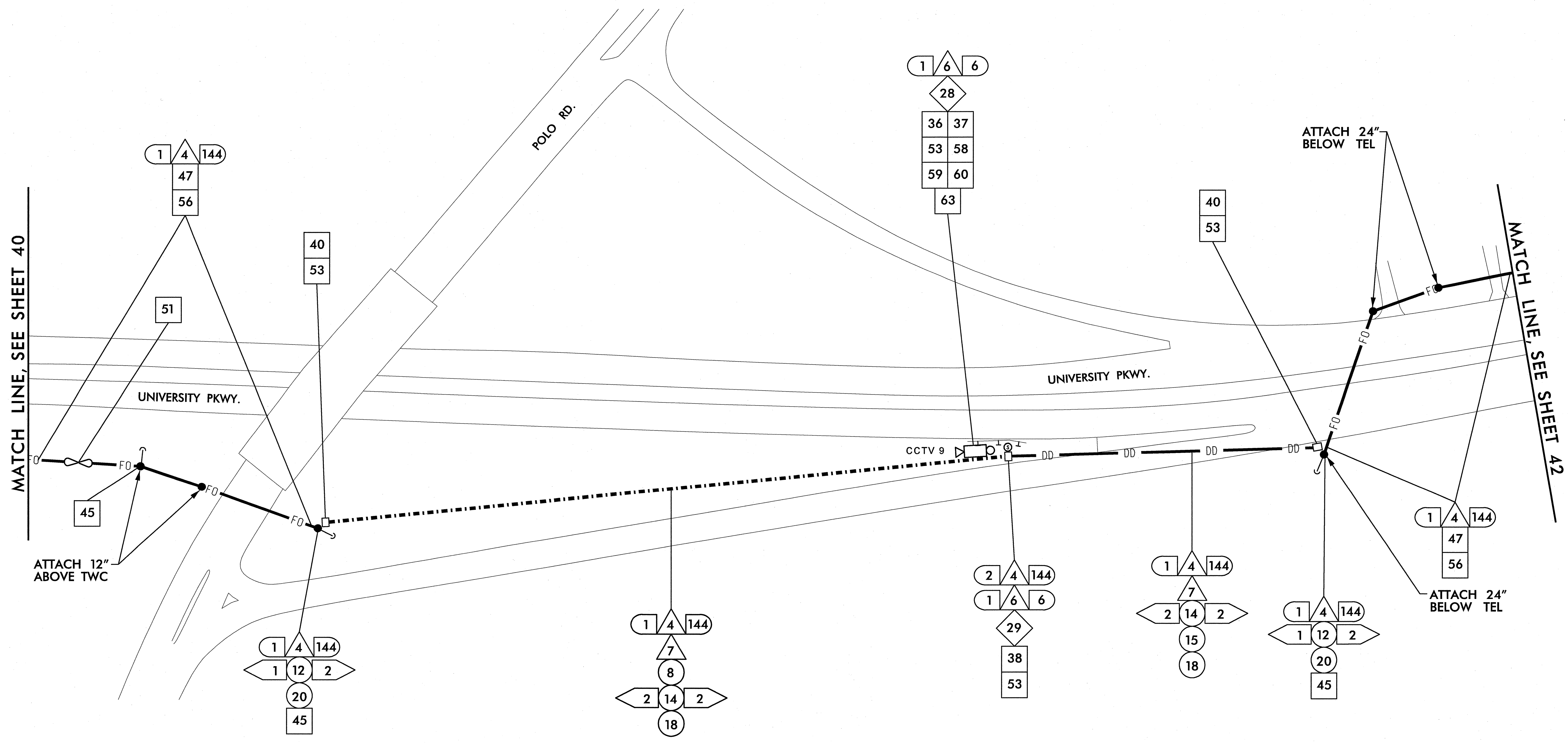

NOTE:
ATTACH 40" BELOW POWER, FRONT SIDE OF POLE, UNLESS OTHERWISE NOTED

1/25/2011 11:46:42 AM jerry.cross k:\na1_tproj_its\01038158-us_92_1ts (u-2826b)\plan\sh4.dgn

PLANS PREPARED IN THE OFFICE OF:

Kimley-Horn and Associates, Inc.
 P.O. Box 33068
 Raleigh, N.C. 27636-3068
 (919) 677-2000
 N.C. License # F-0102

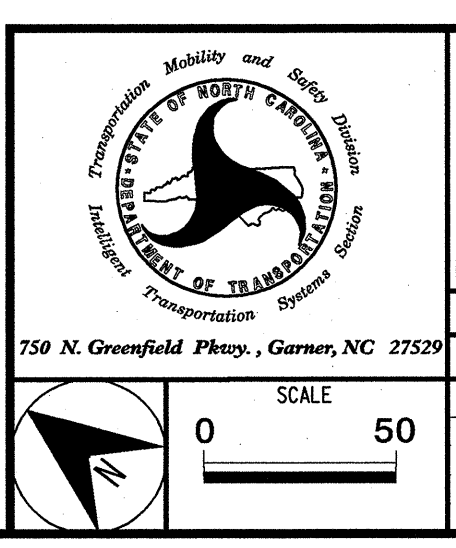

U-2826B	
CABLE ROUTING PLAN SHEET	
DIVISION 9 FORSYTH COUNTY WINSTON SALEM	
PLAN DATE: JANUARY 2011	REVIEWED BY:
PREPARED BY: J. Cross	REVIEWED BY: S. Privette
REVISIONS	INIT. DATE

SEAL

STEPHANIE B. PRIVETTE
 PROFESSIONAL ENGINEER
 STATE OF NORTH CAROLINA
 LICENSE NO. 24432

DATE: _____
 SIGNATURE:

CADD Filenames: _____

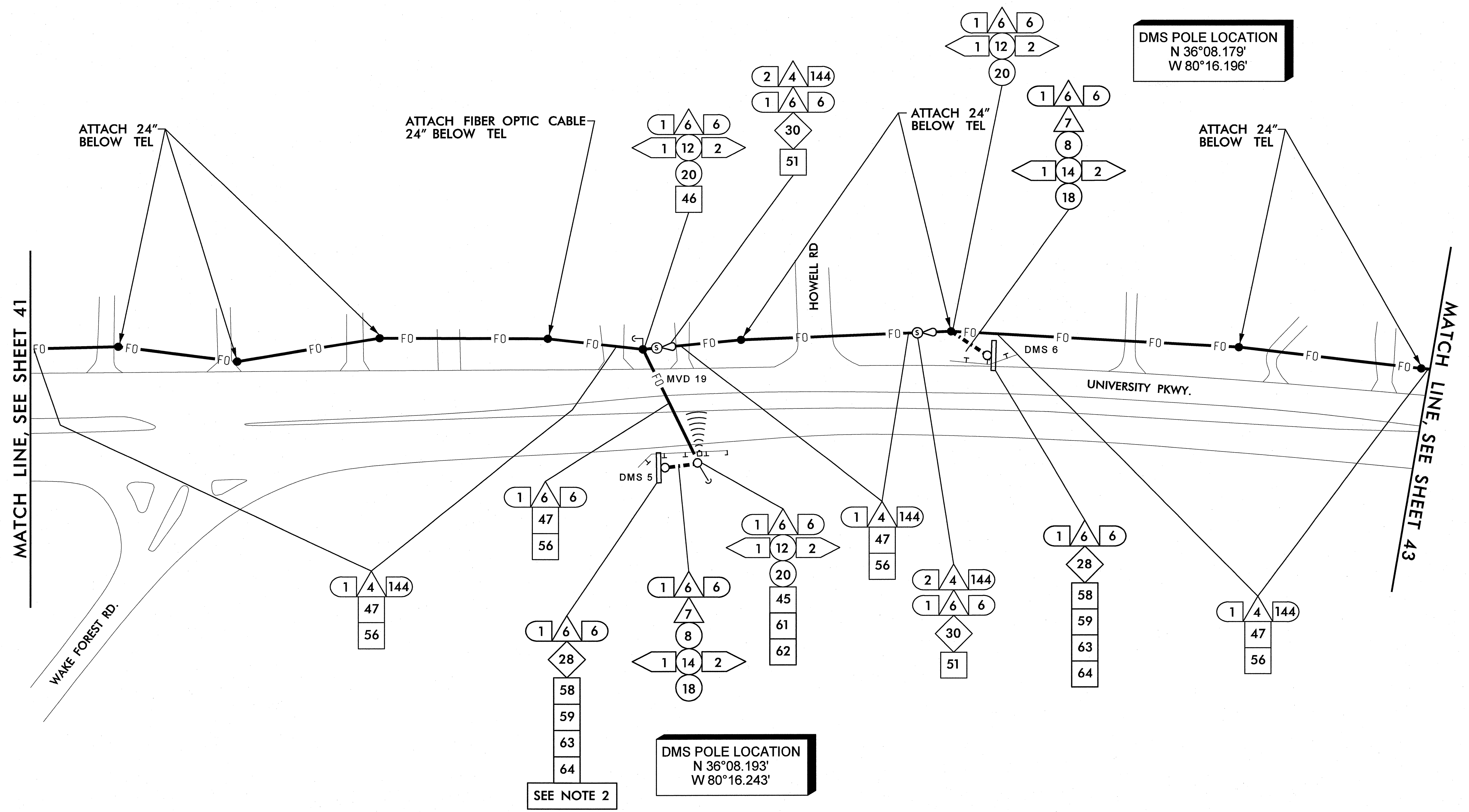

NOTES:
 1. ATTACH 40" BELOW POWER, FRONT SIDE OF POLE, UNLESS OTHERWISE NOTED.
 2. INSTALL MVD EQUIPMENT IN DMS EQUIPMENT CABINET.

1/25/2011 11:46:39 AM jerry.cross k:\real_tproj_its\01060608-06_p2_1ts (U-2826B)\plan\Shr 042.dgn

PLANS PREPARED IN THE OFFICE OF:

Kimley-Horn and Associates, Inc.
 P.O. Box 33068
 Raleigh, N.C. 27636-3068
 (919) 677-2000
 N.C. License # F-0102

U-2826B	
CABLE ROUTING PLAN SHEET	
DIVISION 9 FORSYTH COUNTY WINSTON SALEM	
PLAN DATE: JANUARY 2011	REVIEWED BY:
PREPARED BY: J. Cross	REVIEWED BY: S. Privette
REVISIONS	INIT. DATE

SEAL

SIGNATURE: *Stephanie B. Privette* DATE: 1-25-11
 CADD File:

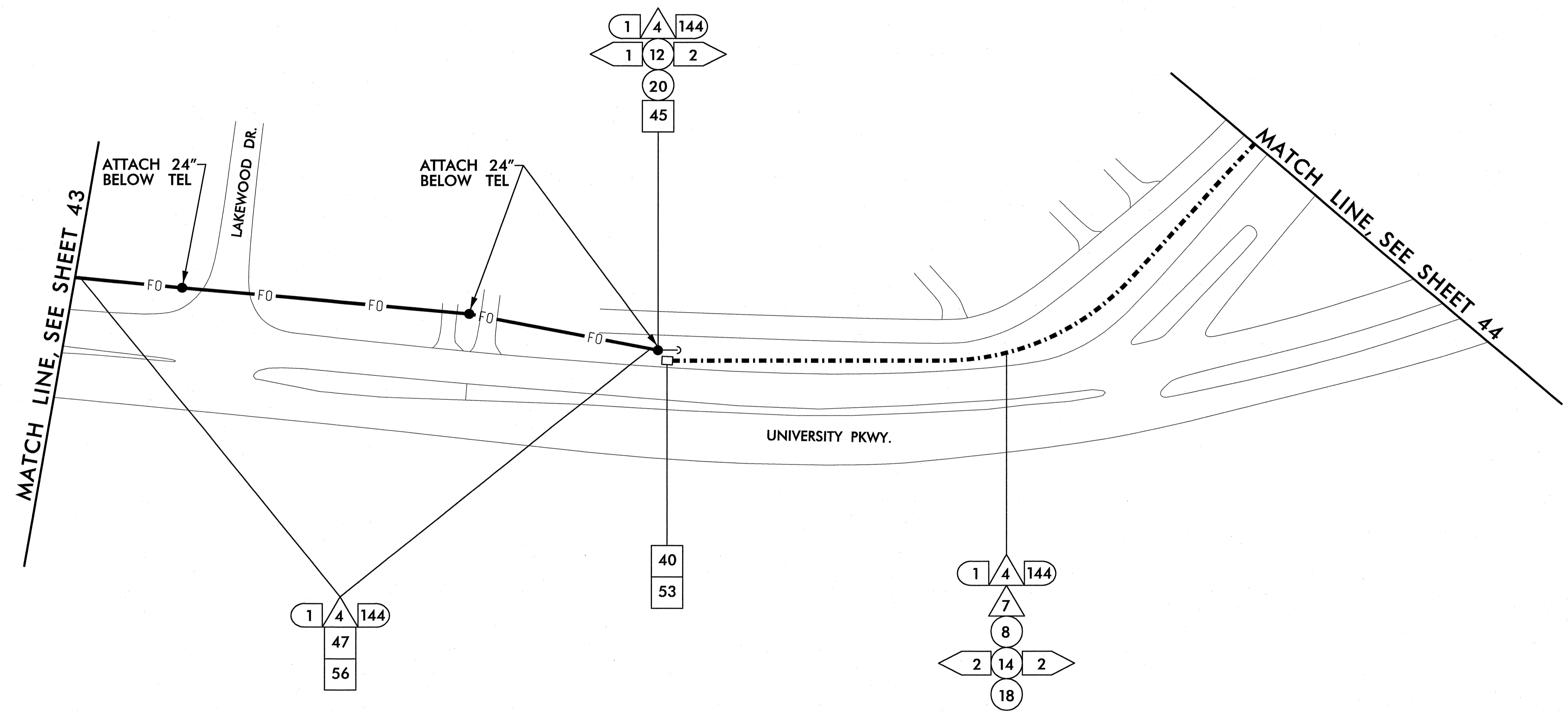

NOTE:
ATTACH 40" BELOW POWER, FRONT SIDE
OF POLE, UNLESS OTHERWISE NOTED

k:\na\proj\its\0108858-us_82_its (u-2826B)\plan\sh4 043.dgn
 11:46:44 AM jerry.cross
 1/25/2011

PLANS PREPARED IN
THE OFFICE OF:

**Kimley-Horn
and Associates, Inc.**
P.O. Box 33068
Raleigh, N.C. 27636-3068
(919) 677-2000
N.C. License # F-0102

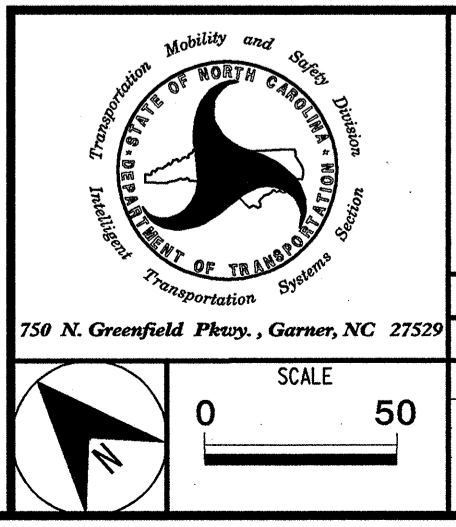

U-2826B	
CABLE ROUTING PLAN SHEET	
DIVISION 9 FORSYTH COUNTY WINSTON SALEM	
PLAN DATE: JANUARY 2011	REVIEWED BY:
PREPARED BY: J. Cross	REVIEWED BY: S. Privette
REVISIONS	INIT. DATE

SEAL

SEAL
24432
ENGINEER
STEPHANIE B. PRIVETTE

Stephanie B. Privette 1-25-11
SIGNATURE DATE

CADD Filename:

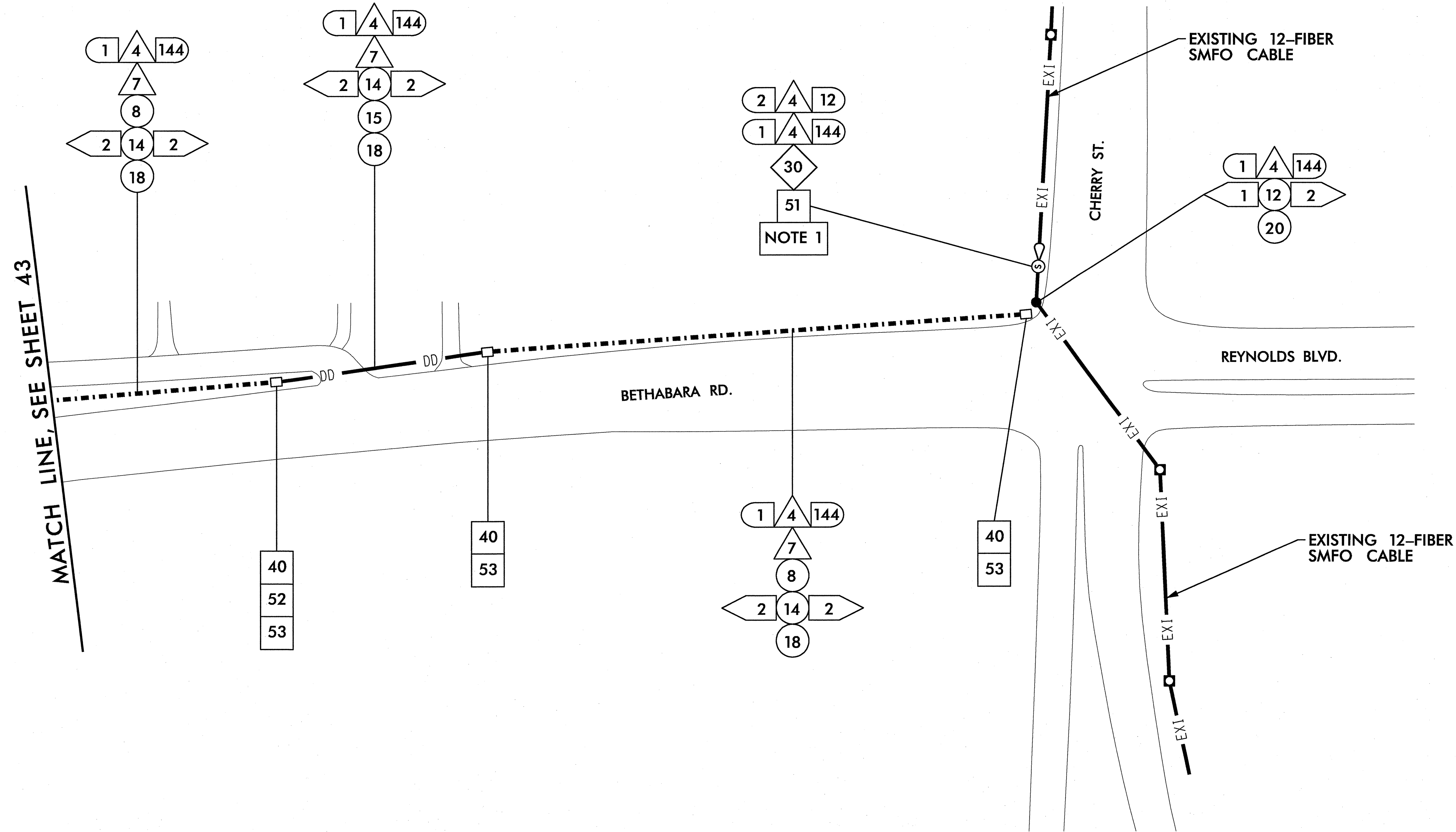

NOTE:
1. SPLICE SLACK INTO EXISTING FIBER OPTIC CABLE.

1/25/2011 11:46:45 AM jerry.cross k:\ra1_prio_its\01\086\58-us_52_1ts (U-2826B)\dwm\Sheet 044.dwg

PLANS PREPARED IN THE OFFICE OF:

Kimley-Horn and Associates, Inc.
P.O. Box 33068
Raleigh, N.C. 27636-3068
(919) 677-2000
N.C. License # F-0102

750 N. Greenfield Pkwy., Garner, NC 27529

U-2826B	
CABLE ROUTING PLAN SHEET	
DIVISION 9 FORSYTH COUNTY WINSTON SALEM	
PLAN DATE: JANUARY 2011	REVIEWED BY:
PREPARED BY: J. Cross	REVIEWED BY: S. Privette
REVISIONS	INIT. DATE

SEAL

STEPHANIE B. PRIVETTE

1-25-11

DATE

CADD Files

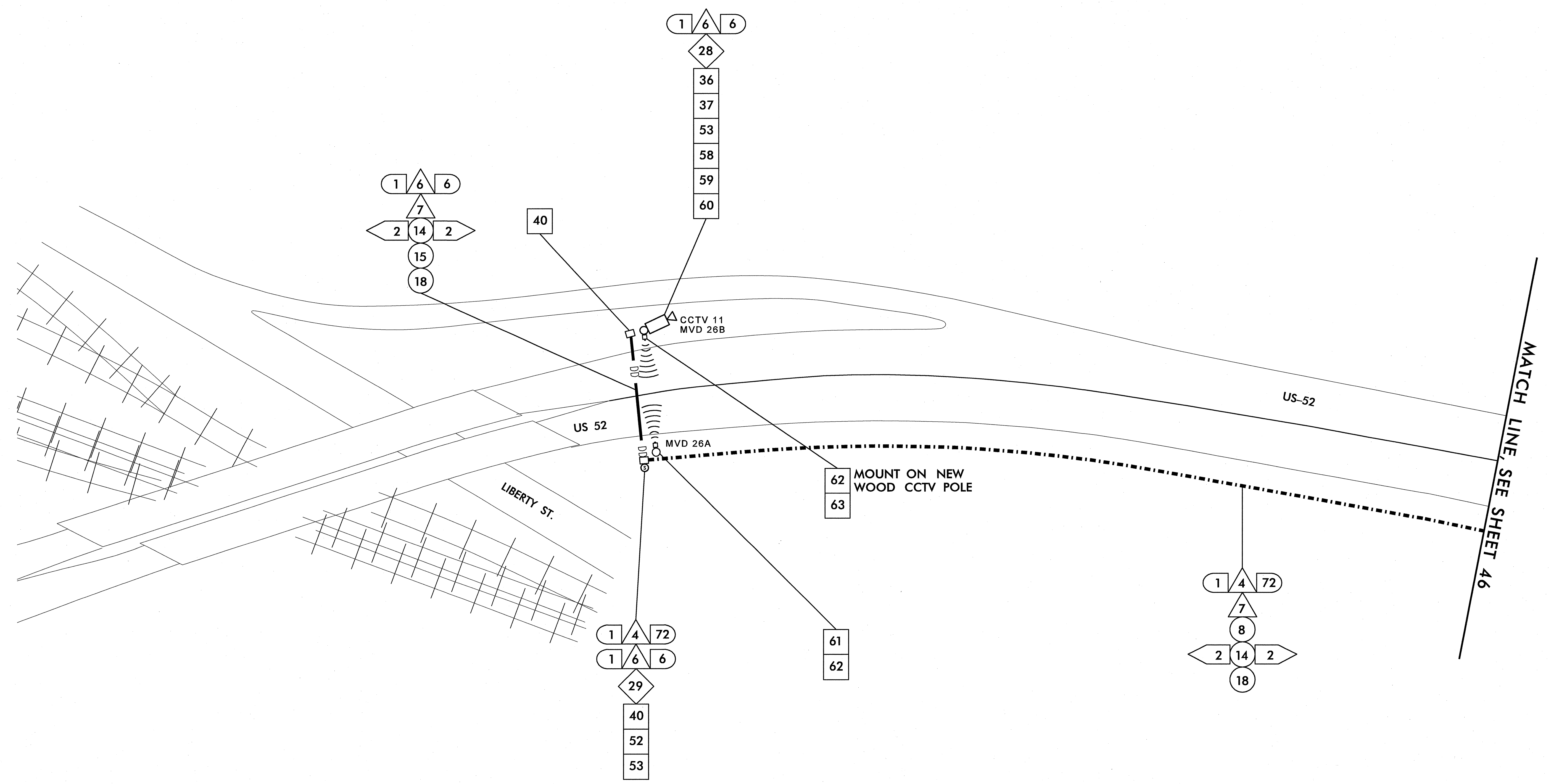

1/25/2011 11:46:46 AM jerry.cross k:\ral_tpro_tfs\01056588-us 52_its (u-2826b)\plan\sh 045.dgn

PLANS PREPARED IN THE OFFICE OF:

Kimley-Horn and Associates, Inc.
 P.O. Box 33068
 Raleigh N.C. 27636-3068
 (919) 677-2000
 N.C. License # F-0102

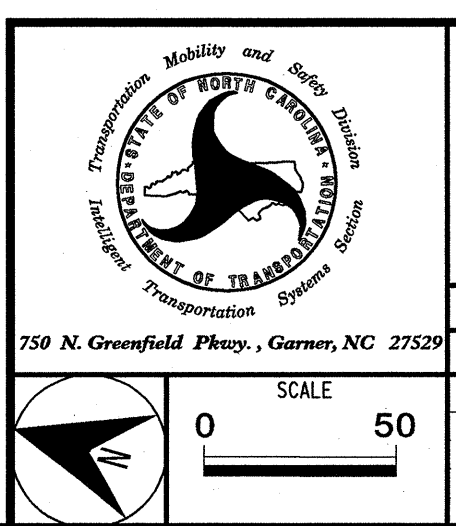

U-2826B	
CABLE ROUTING PLAN SHEET	
DIVISION 9 FORSYTH COUNTY WINSTON SALEM	
PLAN DATE: JANUARY 2011	REVIEWED BY:
PREPARED BY: J. Cross	REVIEWED BY: S. Privette
REVISIONS	INIT. DATE

SEAL

SIGNATURE: *Stephanie B. Privette* DATE: 1-25-11
 CADD Filename:

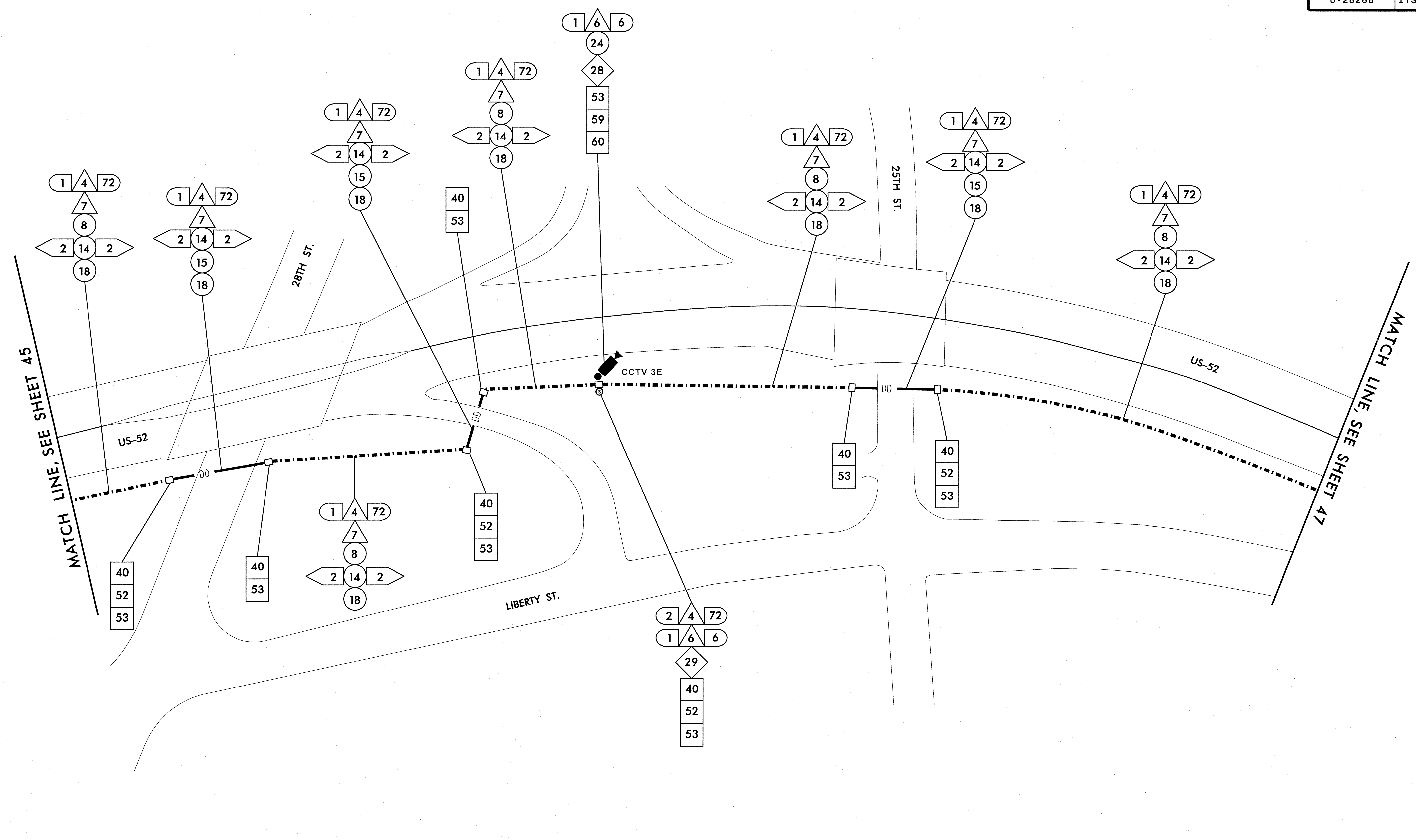

k:\rad_tproj_its\0106168-us 52_its (u-2826b)\plan\sh 46.dgn
 11:46:47 AM jerry.cross
 1/25/2011

PLANS PREPARED IN THE OFFICE OF:

Kimley-Horn and Associates, Inc.
 P.O. Box 33068
 Raleigh N.C. 27636-3068
 (919) 677-2000
 N.C. License # F-0102

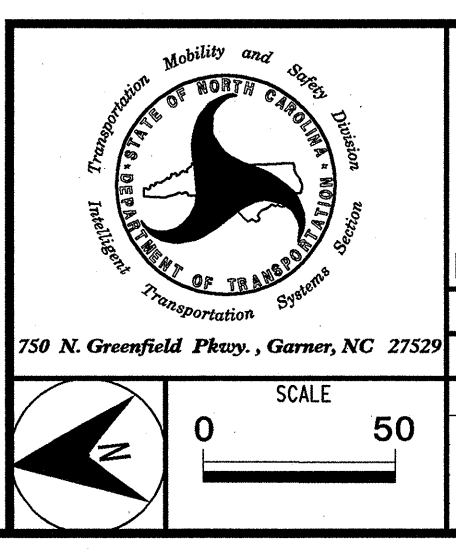

U-2826B	
CABLE ROUTING PLAN SHEET	
DIVISION 9 FORSYTH COUNTY WINSTON SALEM	
PLAN DATE: JANUARY 2011	REVIEWED BY:
PREPARED BY: J. Cross	REVIEWED BY: S. Privette
REVISIONS	INIT. DATE

SEAL

SIGNATURE: *Stephanie B. Privette* DATE: 1-25-11
 CADD Filename:

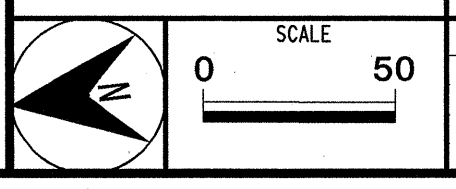

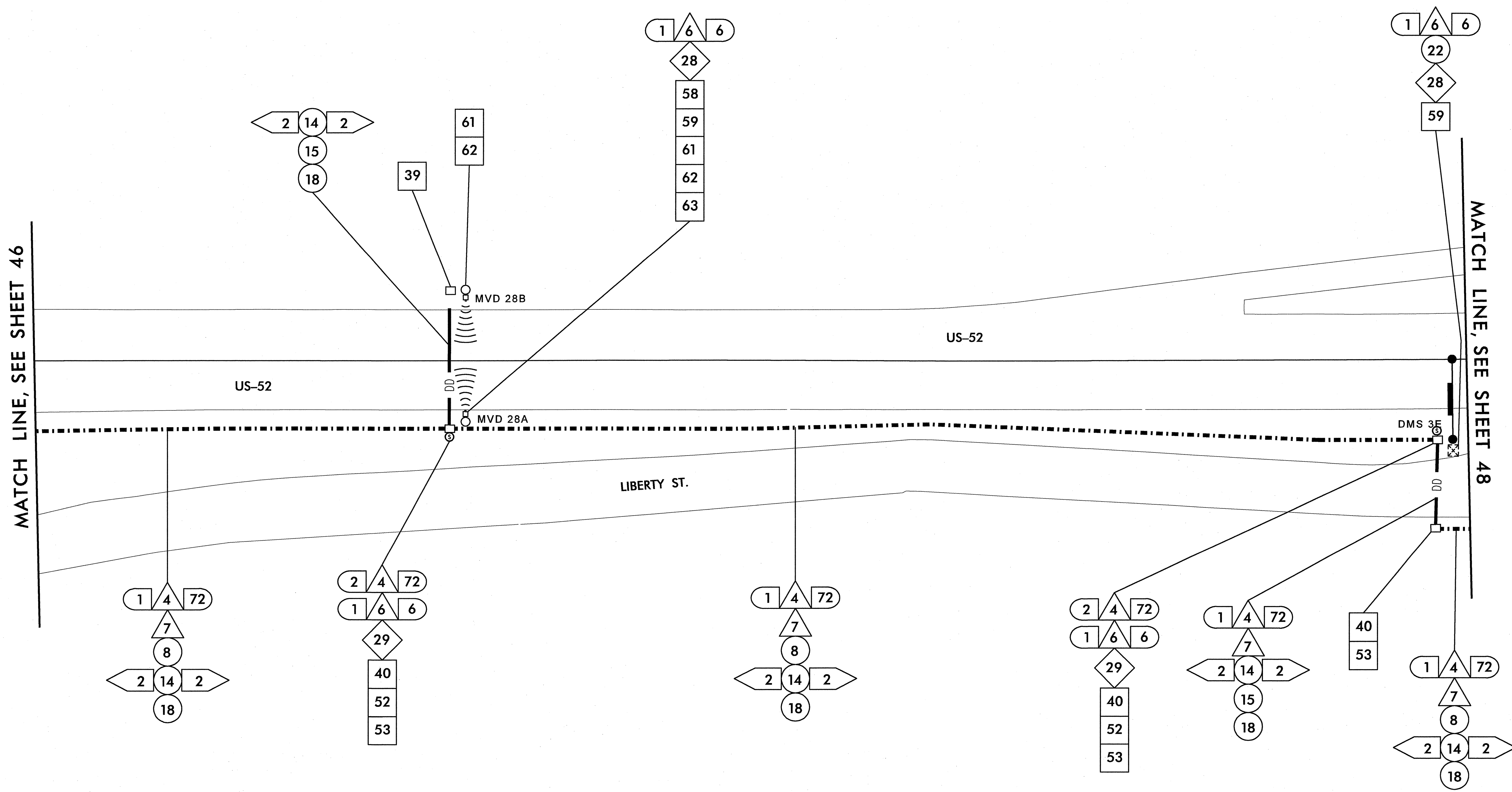

NOTE:
1. REMOVE EXISTING COMMUNICATIONS EQUIPMENT.

1/25/2011 11:46:48 AM jerry.cross k:\rad_tproj_its\01066158-us 52_its (u-2826B)\plan\sh47.dgn

PLANS PREPARED IN THE OFFICE OF:

Kimley-Horn and Associates, Inc.
 P.O. Box 33068
 Raleigh, N.C. 27636-3068
 (919) 677-2000
 N.C. License # F-0102

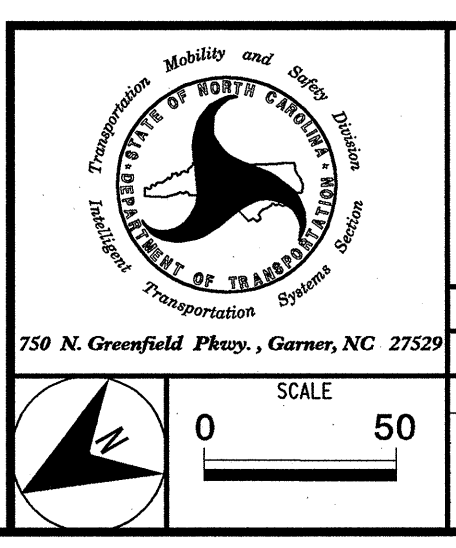

U-2826B	
CABLE ROUTING PLAN SHEET	
DIVISION 9 FORSYTH COUNTY WINSTON SALEM	
PLAN DATE: JANUARY 2011	REVIEWED BY:
PREPARED BY: J. Cross	REVIEWED BY: S. Privette
REVISIONS	INIT. DATE

SEAL

SIGNATURE DATE 1.26.11
 CADD Filename:

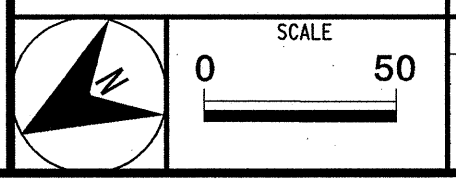

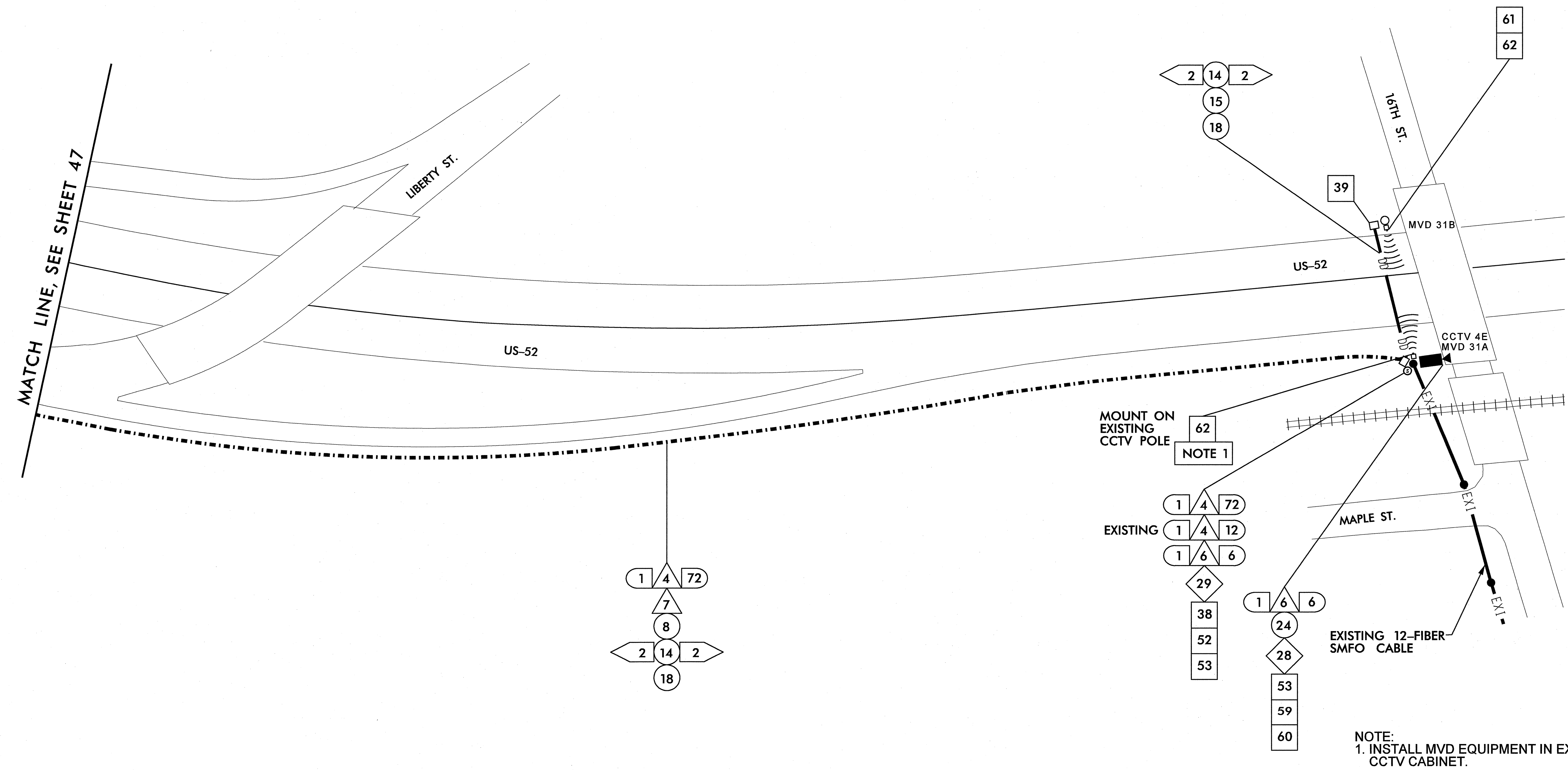

1/25/2011 11:46:49 AM jerry.cross k:\val_tproj_its\01026158-us_52_1ts (U-2826B)\plan\sh1 c48.dgn

PLANS PREPARED IN THE OFFICE OF:

Kimley-Horn and Associates, Inc.
 P.O. Box 33068
 Raleigh, N.C. 27636-3068
 (919) 677-2000
 N.C. License # F-0102

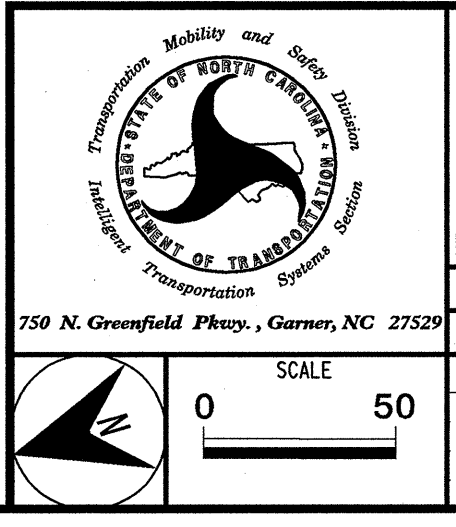

U-2826B	
CABLE ROUTING PLAN SHEET	
DIVISION 9 FORSYTH COUNTY WINSTON SALEM	
PLAN DATE: JANUARY 2011	REVIEWED BY:
PREPARED BY: J. Cross	REVIEWED BY: S. Privette
REVISIONS	INIT. DATE

SEAL

STEPHANIE B. PRIVETTE
 PROFESSIONAL ENGINEER
 SEAL 24432

SIGNATURE DATE 1-26-11

CADD Filename:

MATCH LINE, SEE SHEET 50

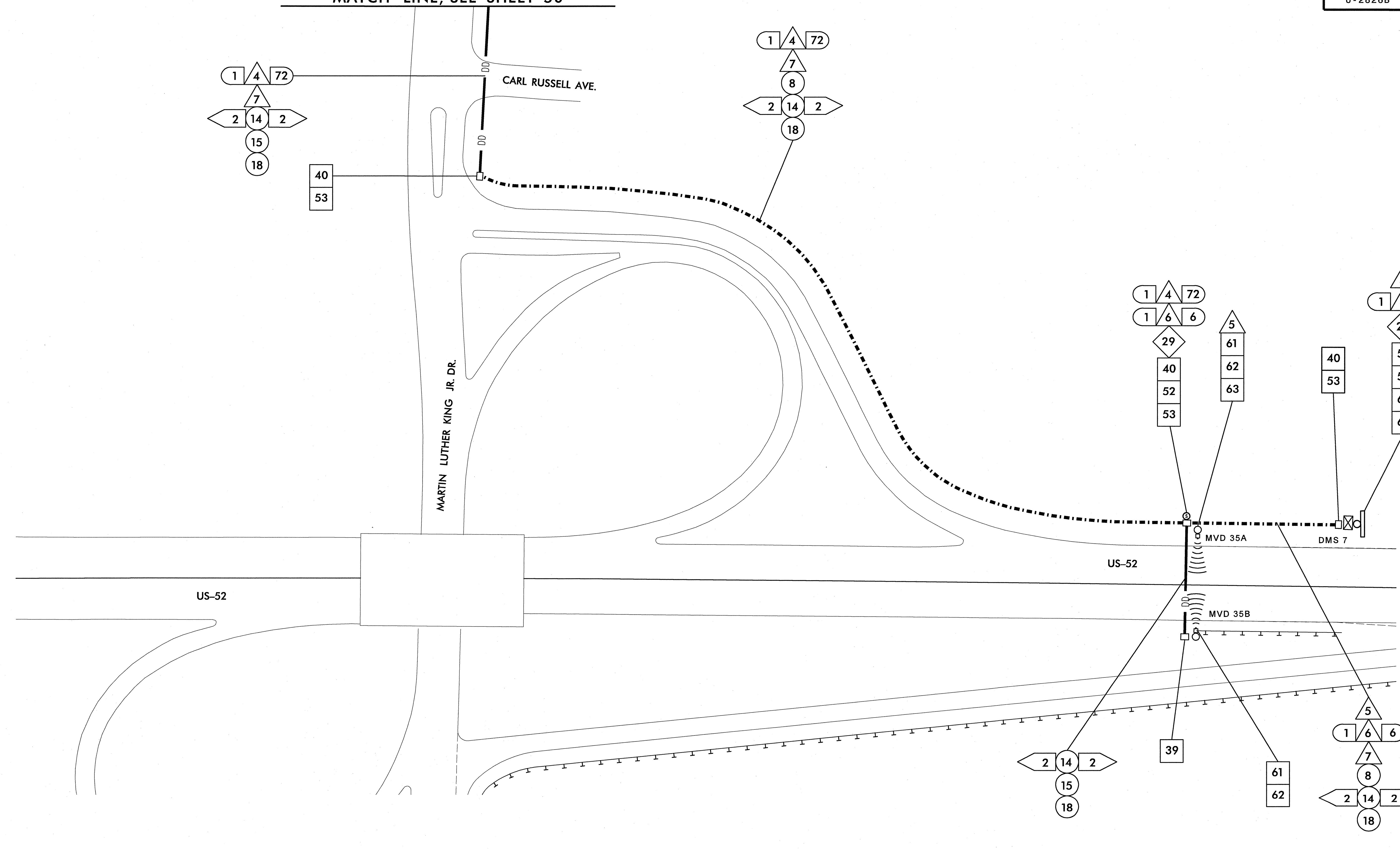

1/25/2011 11:46:50 AM jerry.cross
 k:\121_inpro_its\0108156-us 52_its (u-2826b)\plan\sh1 049.dgn

PLANS PREPARED IN THE OFFICE OF:

Kimley-Horn and Associates, Inc.
 P.O. Box 33068
 Raleigh N.C. 27636-3068
 (919) 677-2000
 N.C. License # F-0102

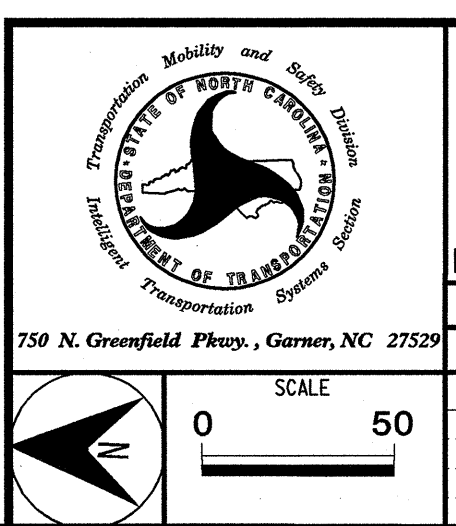

U-2826B	
CABLE ROUTING PLAN SHEET	
DIVISION 9 FORSYTH COUNTY WINSTON SALEM	
PLAN DATE: JANUARY 2011	REVIEWED BY:
PREPARED BY: J. Cross	REVIEWED BY: S. Privette
REVISIONS	INIT. DATE

SEAL

 SIGNATURE: *Stephanie B. Privette* DATE: 1-25-11
 CADD Filename:

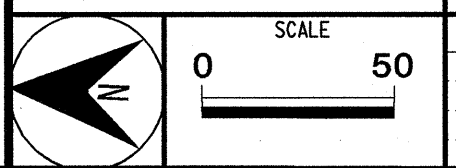

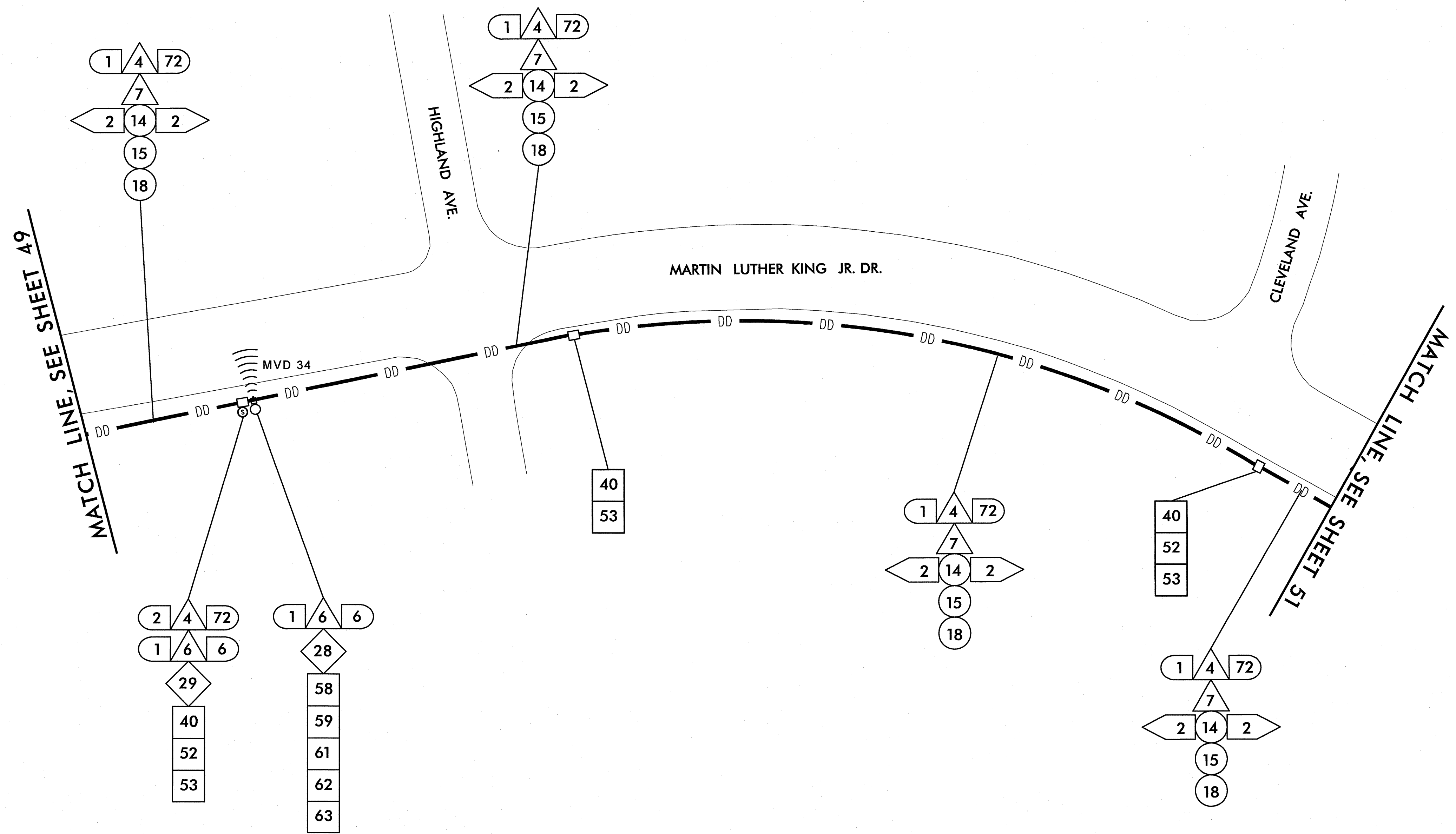

1/25/2011 11:46:51 AM jerry.cross k:\real\proj_its\01086158-us 52_its (u-2826B)\plan\sh1 650.dgn

PLANS PREPARED IN THE OFFICE OF:

Kimley-Horn and Associates, Inc.
 P.O. Box 33068
 Raleigh N.C. 27636-3068
 (919) 677-2000
 N.C. License # F-0102

750 N. Greenfield Pkwy., Garner, NC 27529
 SCALE 0 50

U-2826B	
CABLE ROUTING PLAN SHEET	
DIVISION 9 FORSYTH COUNTY WINSTON SALEM	
PLAN DATE: JANUARY 2011	REVIEWED BY:
PREPARED BY: J. Cross	REVIEWED BY: S. Privette
REVISIONS	INIT. DATE

SEAL

SIGNATURE: DATE: 1.25.11
 CADD Filenames:

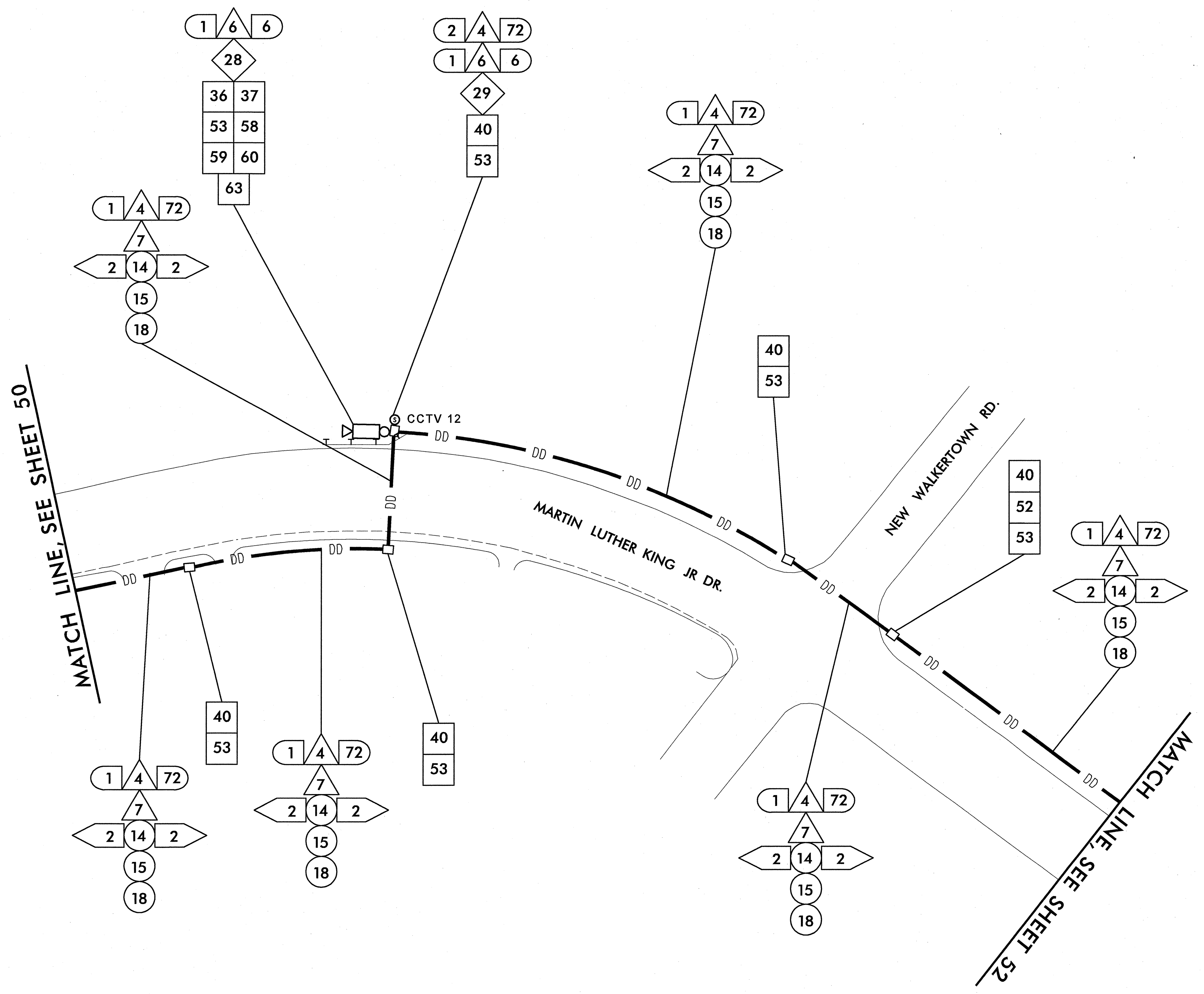

1/25/2011 11:46:52 AM jerry.cross k:\rd_tproj_its\01108658-us 52_its (U-2826B)\plan\sh 051.dgn

PLANS PREPARED IN THE OFFICE OF:

Kimley-Horn and Associates, Inc.
 P.O. Box 33068
 Raleigh N.C. 27636-3068
 (919) 677-2000
 N.C. License # F-0102

750 N. Greenfield Pkwy., Garner, NC 27529
 SCALE 0 50

U-2826B	
CABLE ROUTING PLAN SHEET	
DIVISION 9 FORSYTH COUNTY WINSTON SALEM	
PLAN DATE: JANUARY 2011	REVIEWED BY:
PREPARED BY: J. Cross	REVIEWED BY: S. Privette
REVISIONS	INIT. DATE

SEAL

SIGNATURE: *Stephanie B. Privette* DATE: 1-25-11
 CADD Filename:

MATCH LINE, SEE SHEET 51

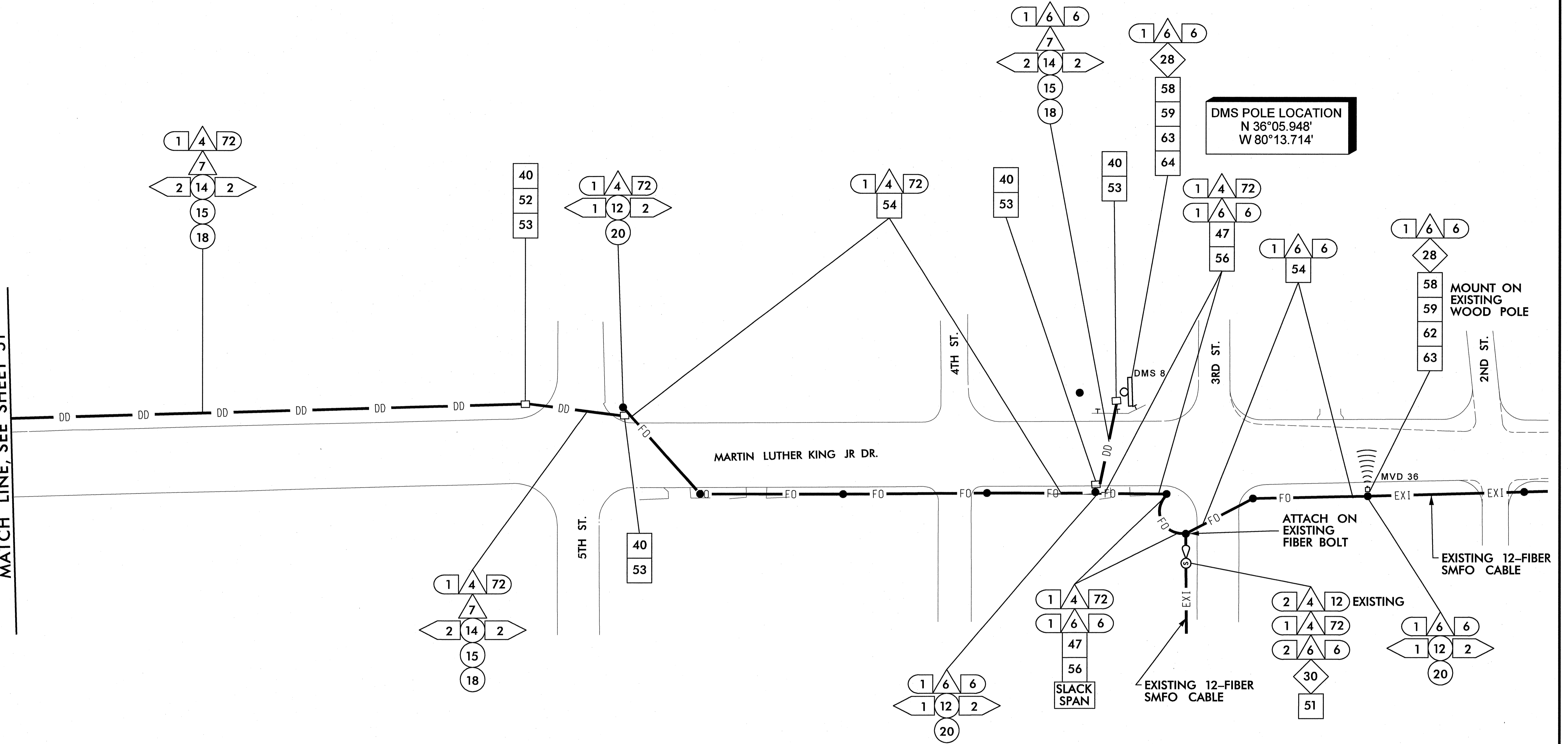

NOTE:
ATTACH 40" BELOW POWER, FRONT SIDE
OF POLE, UNLESS OTHERWISE NOTED

1/25/2011 11:46:54 AM jerry.cross k:\real_tproj_its\0108189-us 52_its (u-2826B)\plan\sh 032.dgn

PLANS PREPARED IN
THE OFFICE OF:

**Kimley-Horn
and Associates, Inc.**
P.O. Box 33068
Raleigh, N.C. 27636-3068
(919) 677-2000
N.C. License # F-0102

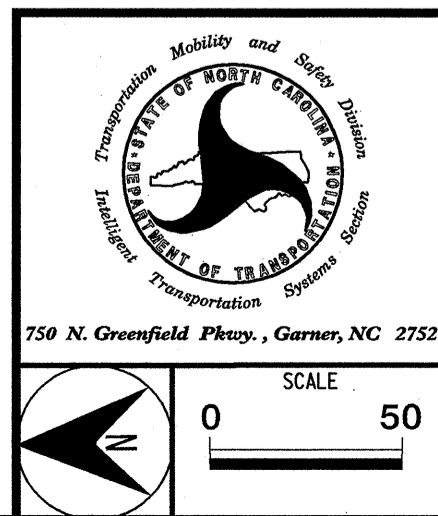

U-2826B	
CABLE ROUTING PLAN SHEET	
DIVISION 9 FORSYTH COUNTY WINSTON SALEM	
PLAN DATE: JANUARY 2011	REVIEWED BY:
PREPARED BY: J. Cross	REVIEWED BY: S. Privette
REVISIONS	INIT. DATE

SEAL

SIGNATURE: *Stephanie B. Privette* DATE: 1-25-11
CADD Filename:

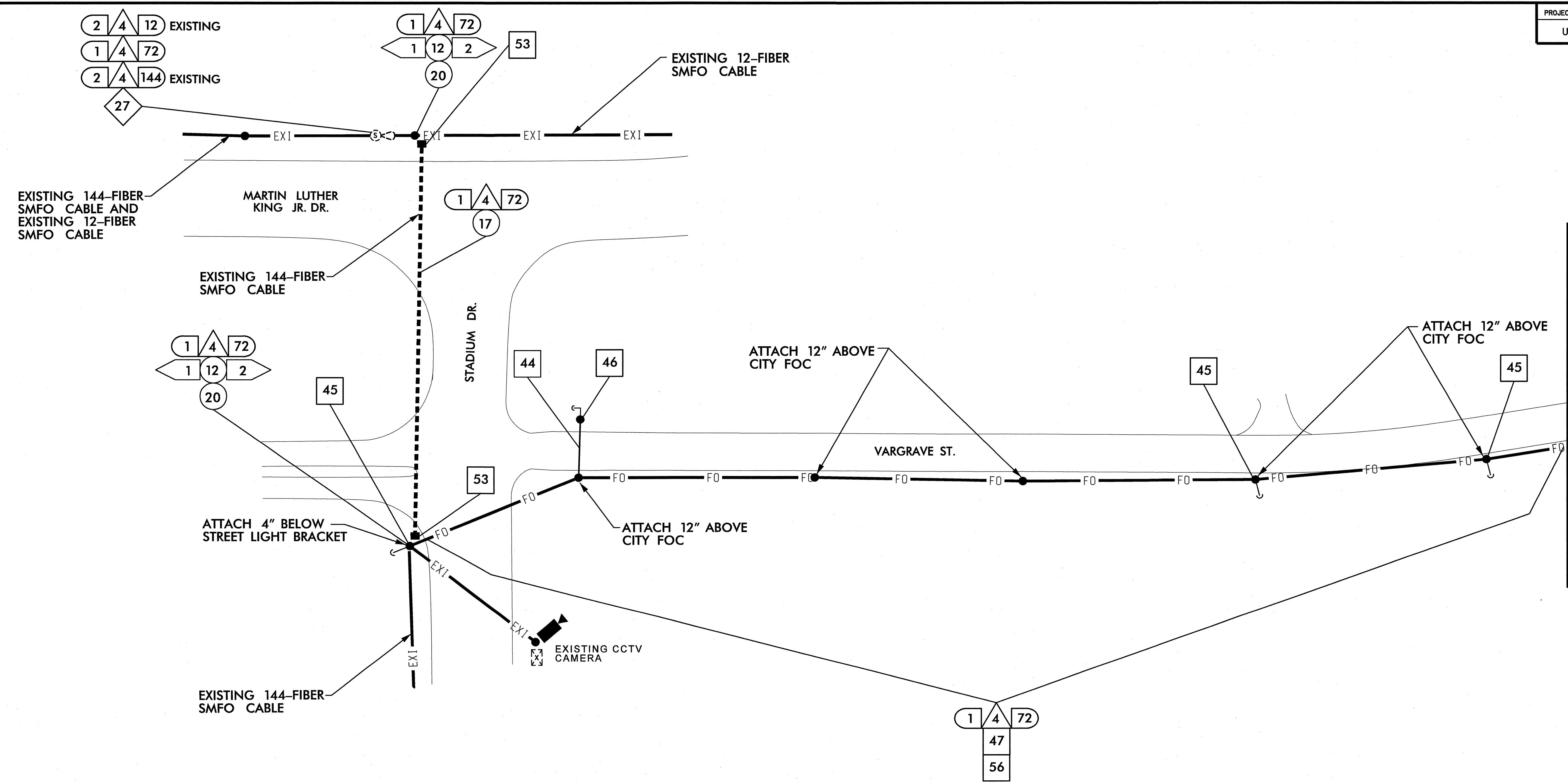

MATCH LINE, SEE SHEET 54

k:\real\proj_its\01086158-us_02_1ts (U-2826B)\plan\SHt 053.dgn
11:46:55 AM jerry.cross
1/25/2011

NOTE S:
1. REMOVE EXISTING COMMUNICATIONS EQUIPMENT.

NOTE:
ATTACH 40" BELOW POWER, FRONT SIDE OF POLE, UNLESS OTHERWISE NOTED

PLANS PREPARED IN THE OFFICE OF:
Kimley-Horn and Associates, Inc.
P.O. Box 33068
Raleigh N.C. 27636-3068
(919) 677-2000
N.C. License # F-0102

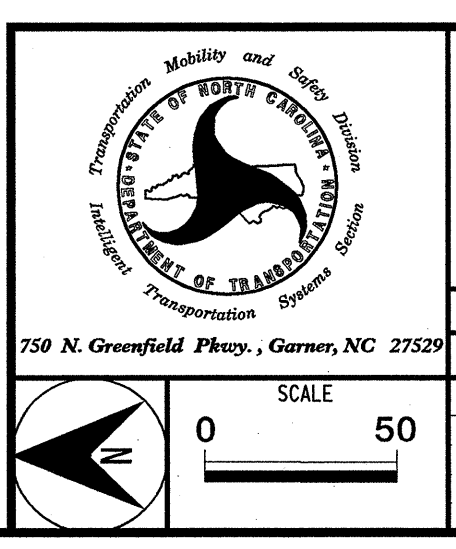

U-2826B	
CABLE ROUTING PLAN SHEET	
DIVISION 9 FORSYTH COUNTY WINSTON SALEM	
PLAN DATE: JANUARY 2011	REVIEWED BY:
PREPARED BY: J. Cross	REVIEWED BY: S. Privette
REVISIONS	INIT. DATE

SEAL
NORTH CAROLINA PROFESSIONAL ENGINEER
SEAL 24432
STEPHANIE B. PRIVETTE
DATE 1-25-11
SIGNATURE
CADD Filename:

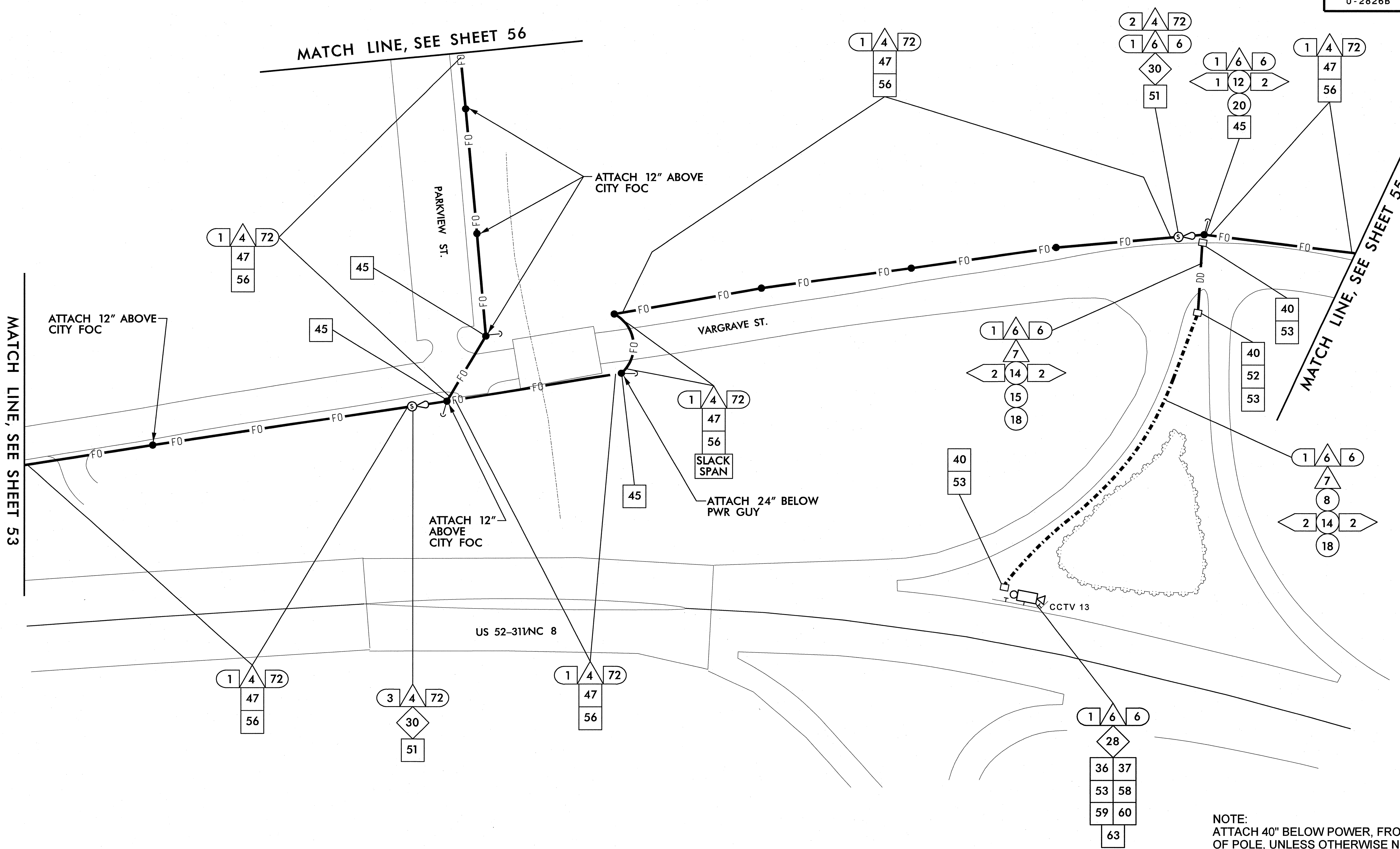

NOTE:
ATTACH 40" BELOW POWER, FRONT SIDE OF POLE, UNLESS OTHERWISE NOTED

k:\na1_pno1_its\01038158-us_52_its\U-2826B\plan\Sheet_054.dwg
 11:46:56 AM jerry.cross
 1/25/2011

PLANS PREPARED IN THE OFFICE OF:

Kimley-Horn and Associates, Inc.
 P.O. Box 33068
 Raleigh, N.C. 27636-3068
 (919) 677-2000
 N.C. License # F-002



U-2826B	
CABLE ROUTING PLAN SHEET	
DIVISION 9 FORSYTH COUNTY WINSTON SALEM	
PLAN DATE: JANUARY 2011	REVIEWED BY:
PREPARED BY: J. Cross	REVIEWED BY: S. Privette
REVISIONS	INIT. DATE

SEAL

SIGNATURE: *Stephanie B. Privette* 1-26-11
DATE

CADD Filename

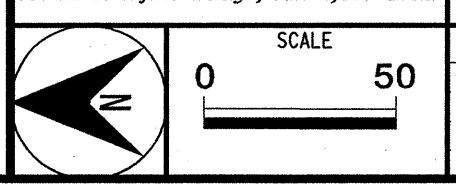

MATCH LINE, SEE SHEET 54

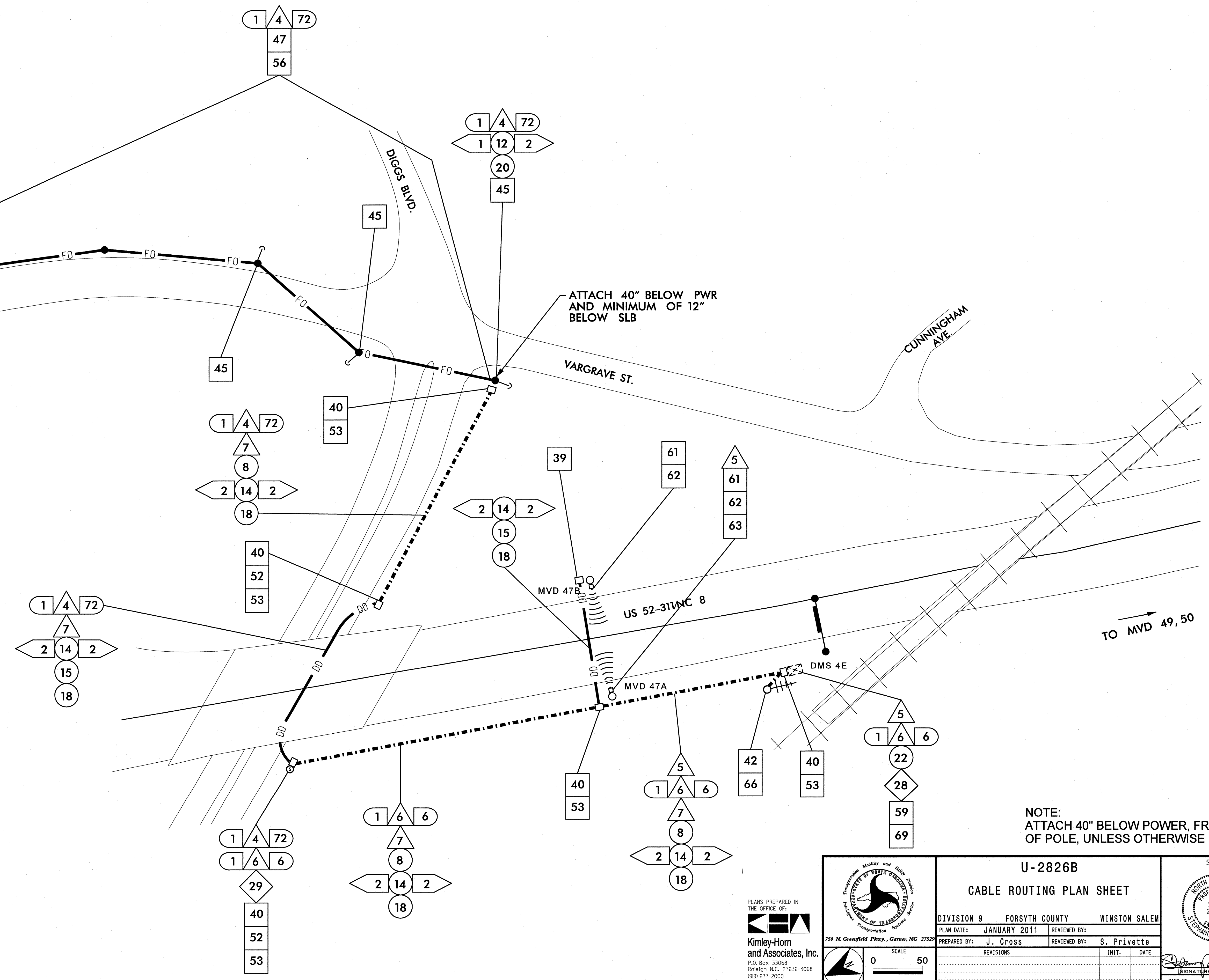

NOTE:
ATTACH 40" BELOW POWER, FRONT SIDE OF POLE, UNLESS OTHERWISE NOTED

1/25/2011 11:46:57 AM jerry.cross k:\real\proj_its\01056158-us_52_its (u-2826b)\plan\sh5 055.dgn

PLANS PREPARED IN THE OFFICE OF:
Kimley-Horn and Associates, Inc.
P.O. Box 33068
Raleigh, N.C. 27636-3068
(919) 677-2000
N.C. License # F-0102

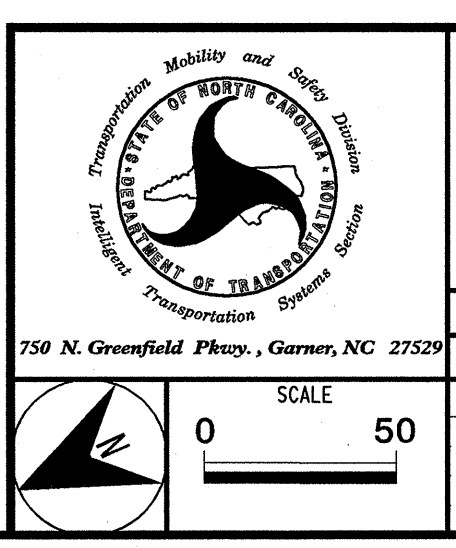

U-2826B	
CABLE ROUTING PLAN SHEET	
DIVISION 9 FORSYTH COUNTY WINSTON SALEM	
PLAN DATE: JANUARY 2011	REVIEWED BY:
PREPARED BY: J. Cross	REVIEWED BY: S. Privette
SCALE: 0 50	REVISIONS
	INIT. DATE

SEAL

SIGNATURE: *Stephanie B. Privette* DATE: 1-25-11

CADD Filenames:

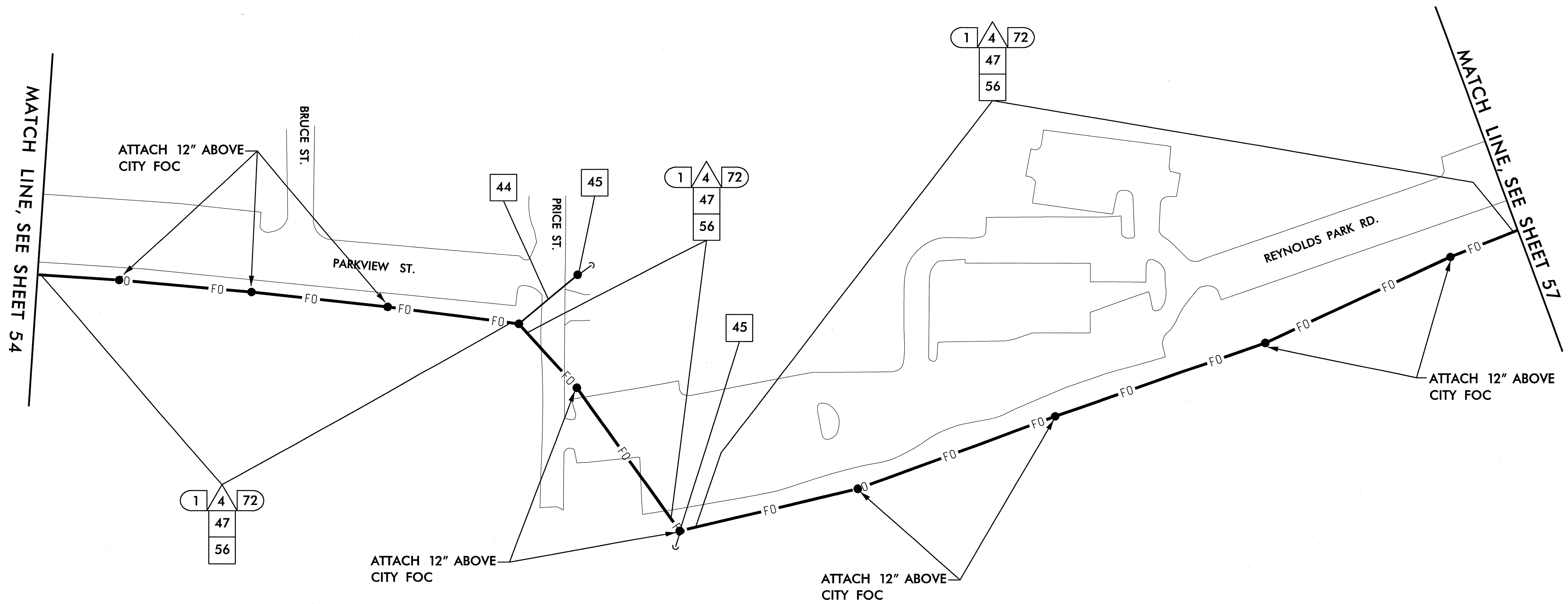

NOTE:
ATTACH 40" BELOW POWER, FRONT SIDE
OF POLE, UNLESS OTHERWISE NOTED

k:\ra1_p101_1ts\01038158-us_52_1ts (u-2826B)\plan\sh1 056.dgn
 11:46:38 AM jerry.cross
 1/25/2011

PLANS PREPARED IN THE OFFICE OF:

Kimley-Horn and Associates, Inc.
 P.O. Box 33068
 Raleigh, N.C. 27636-3068
 (919) 677-2000
 N.C. License # F-0102

750 N. Greenfield Pkwy., Garner, NC 27529

U-2826B	
CABLE ROUTING PLAN SHEET	
DIVISION 9 FORSYTH COUNTY WINSTON SALEM	
PLAN DATE: JANUARY 2011	REVIEWED BY:
PREPARED BY: J. Cross	REVIEWED BY: S. Privette
REVISIONS	INIT. DATE

SEAL

SEAL 24432
 ENGINEER
 STEPHANIE B. PRIVETTE

Stephanie B. Privette 1-25-11
 SIGNATURE DATE

CADD Filename:

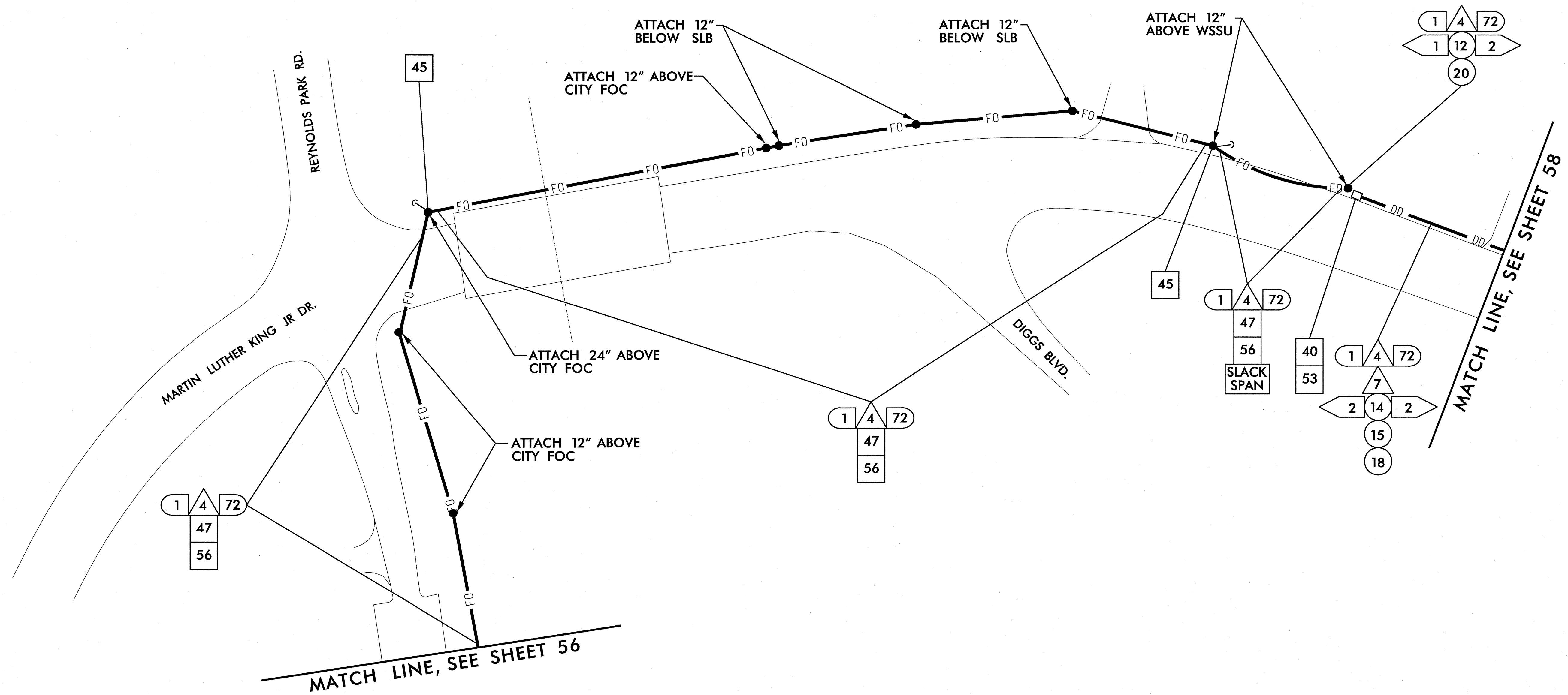

NOTE:
ATTACH 40" BELOW POWER, FRONT SIDE OF POLE, UNLESS OTHERWISE NOTED

1/25/2011 11:46:59 AM jerry.cross k:\val_tproj_its\01086158-us 52_its (u-2826b)\plan\sh57.dgn

PLANS PREPARED IN THE OFFICE OF:

Kimley-Horn and Associates, Inc.
 P.O. Box 33068
 Raleigh N.C. 27636-3068
 (919) 677-2000
 N.C. License # F-0102

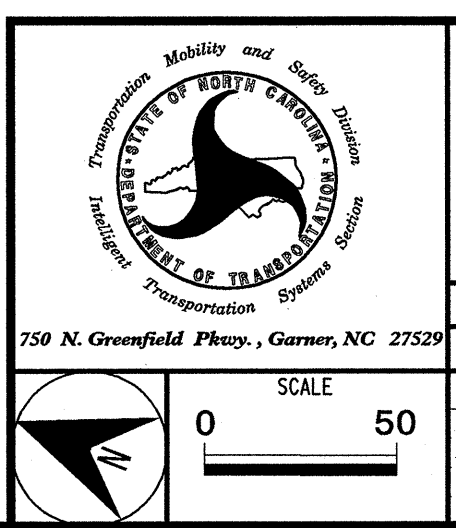

U-2826B	
CABLE ROUTING PLAN SHEET	
DIVISION 9 FORSYTH COUNTY WINSTON SALEM	
PLAN DATE: JANUARY 2011	REVIEWED BY:
PREPARED BY: J. Cross	REVIEWED BY: S. Privette
REVISIONS	INIT. DATE

SEAL

SIGNATURE DATE 1-25-11
 CADD Filename:

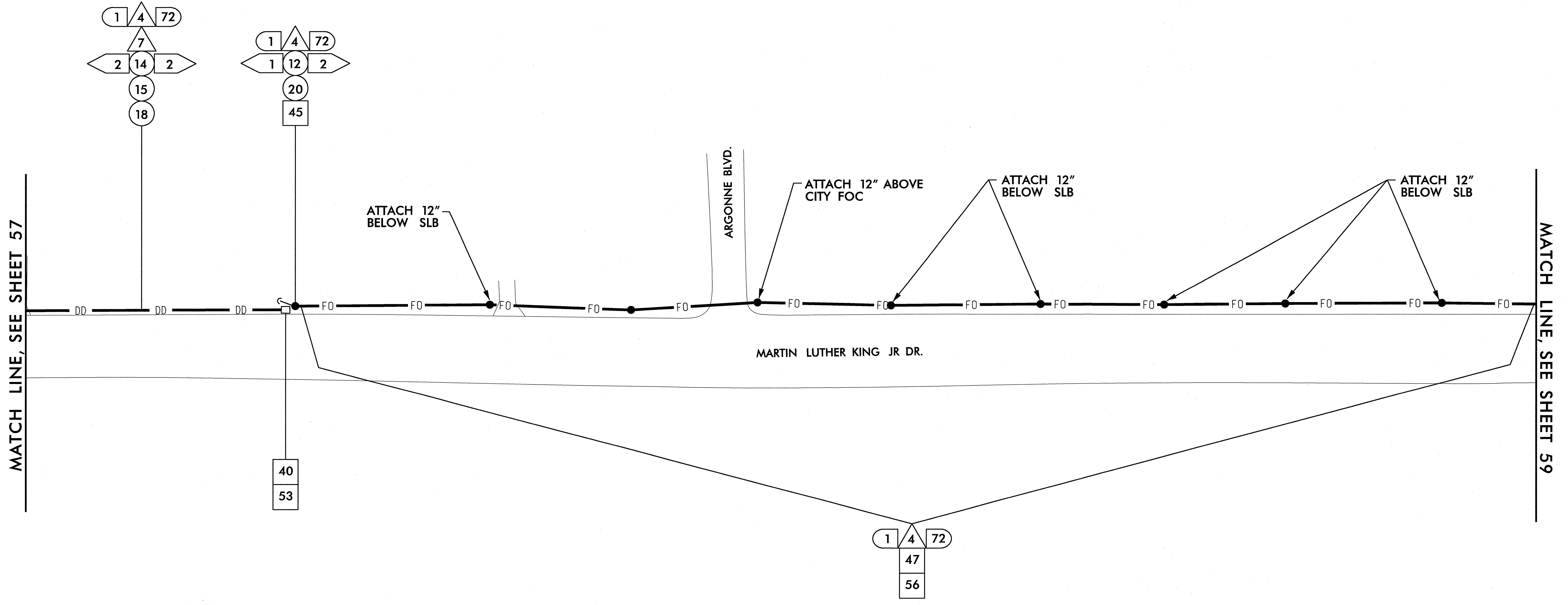

NOTE:
ATTACH 40" BELOW POWER, FRONT SIDE OF POLE, UNLESS OTHERWISE NOTED

1/25/2011 11:47:00 AM jerry.cross k:\rd\proj\its\01036158-us_52_its (u-2826b)\plan\slb.dwg

PLANS PREPARED IN THE OFFICE OF:

Kimley-Horn and Associates, Inc.
 P.O. Box 33068
 Raleigh, N.C. 27636-3068
 (919) 677-2000
 N.C. License # F-0102

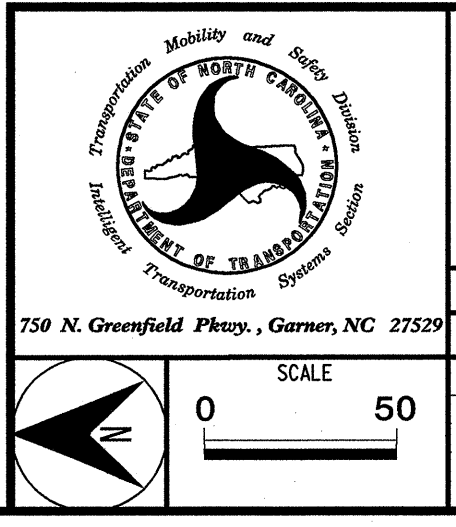

U-2826B	
CABLE ROUTING PLAN SHEET	
DIVISION 9 FORSYTH COUNTY WINSTON SALEM	
PLAN DATE: JANUARY 2011	REVIEWED BY:
PREPARED BY: J. Cross	REVIEWED BY: S. Privette
REVISIONS	INIT. DATE

SEAL

 SIGNATURE: *Stephanie B. Privette* 1-25-11
 DATE: 1-25-11
 CADD Filename:

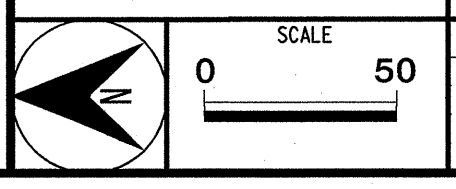

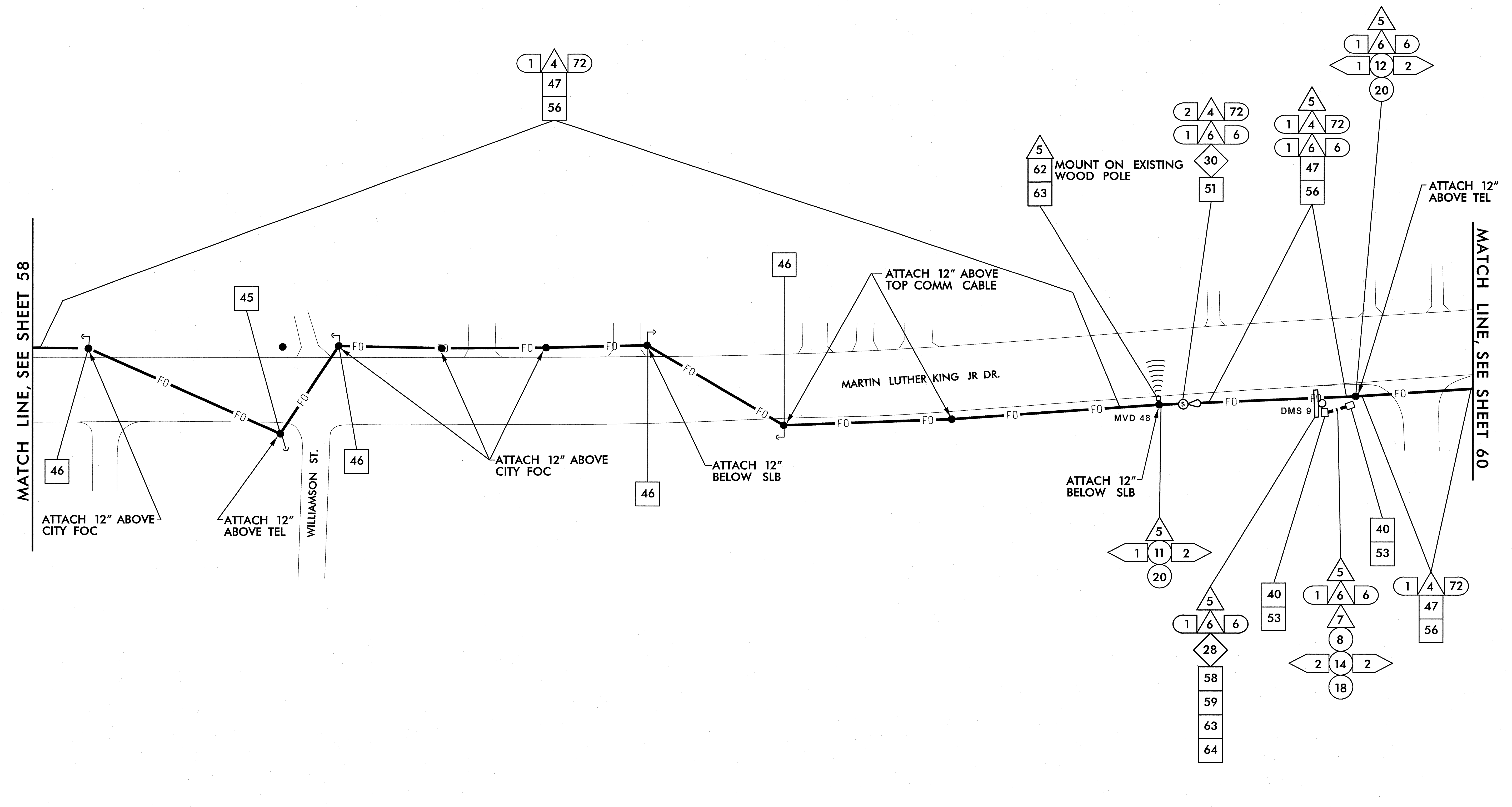

NOTE:
ATTACH 40" BELOW POWER, FRONT SIDE OF POLE, UNLESS OTHERWISE NOTED

1/25/2011 11:47:01 AM jbrty.cross k:\ral_\proj_its\01088159-us_59_its_u-2826b\plan_sht_059.dgn

PLANS PREPARED IN THE OFFICE OF:

Kimley-Horn and Associates, Inc.
 P.O. Box 33068
 Raleigh, N.C. 27636-3068
 (919) 617-2000
 N.C. License # F-0102

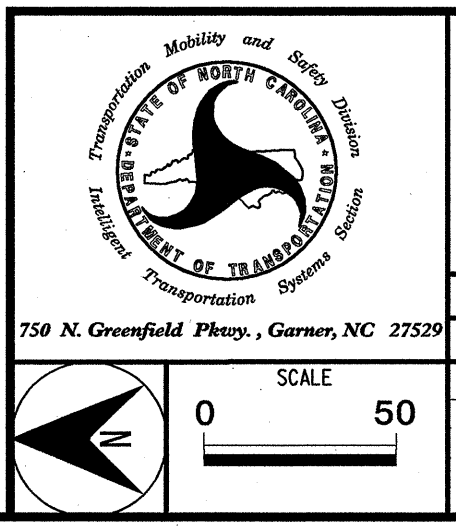

U-2826B	
CABLE ROUTING PLAN SHEET	
DIVISION 9 FORSYTH COUNTY WINSTON SALEM	
PLAN DATE: JANUARY 2011	REVIEWED BY:
PREPARED BY: J. Cross	REVIEWED BY: S. Privette
REVISIONS	INIT. DATE

SEAL

SIGNATURE DATE 1.15.11
 CADD Filename:

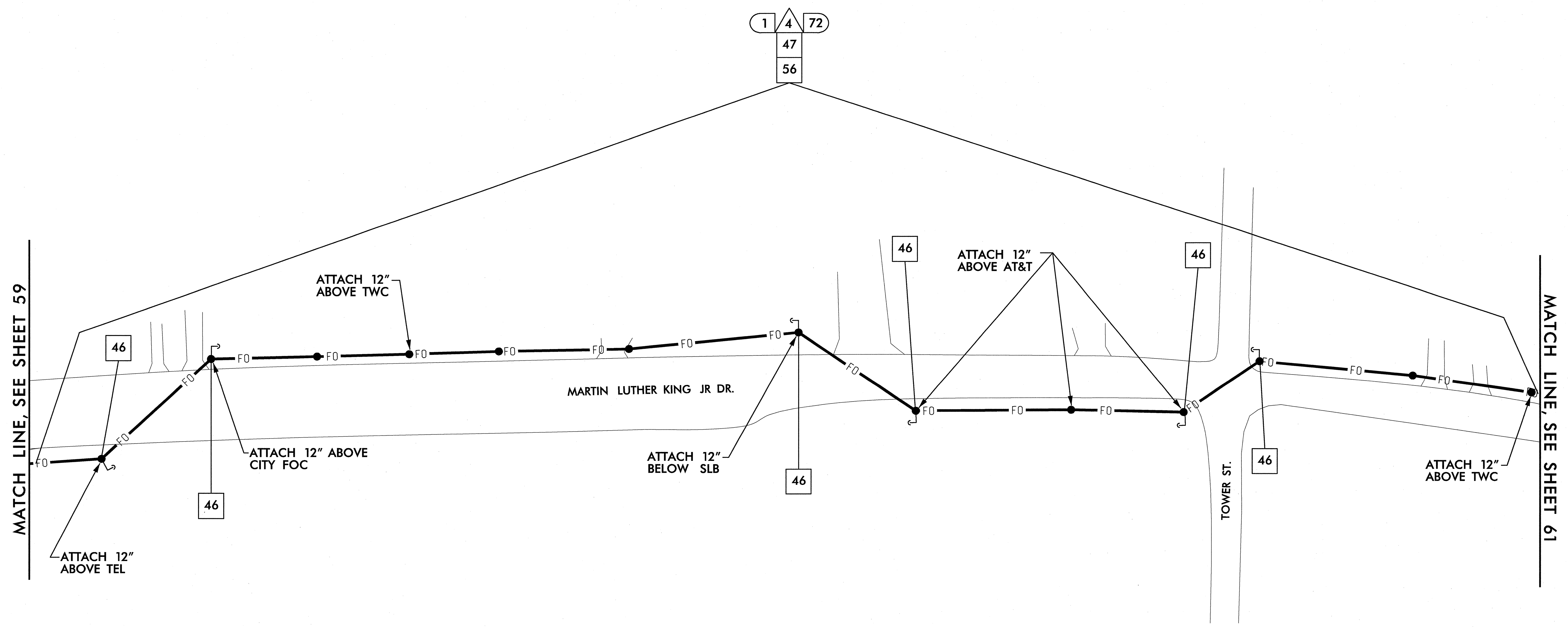

MATCH LINE, SEE SHEET 59

MATCH LINE, SEE SHEET 61

NOTE:
ATTACH 40" BELOW POWER, FRONT SIDE OF POLE, UNLESS OTHERWISE NOTED

1/25/2011 11:47:02 AM jerry.cross k:\nal\proj_its\01038158-us_its (u-2826b)\plan\sh1 060.dgn

PLANS PREPARED IN THE OFFICE OF:

Kimley-Horn and Associates, Inc.
P.O. Box 33068
Raleigh, N.C. 27636-3068
(919) 677-2000
N.C. License # F-0102



U-2826B	
CABLE ROUTING PLAN SHEET	
DIVISION 9 FORSYTH COUNTY WINSTON SALEM	
PLAN DATE: JANUARY 2011	REVIEWED BY:
PREPARED BY: J. Cross	REVIEWED BY: S. Privette
SCALE	0 50
REVISIONS	INIT. DATE

SEAL

STEPHANIE B. PRIVETTE
1-25-11
DATE

CADD Filenames

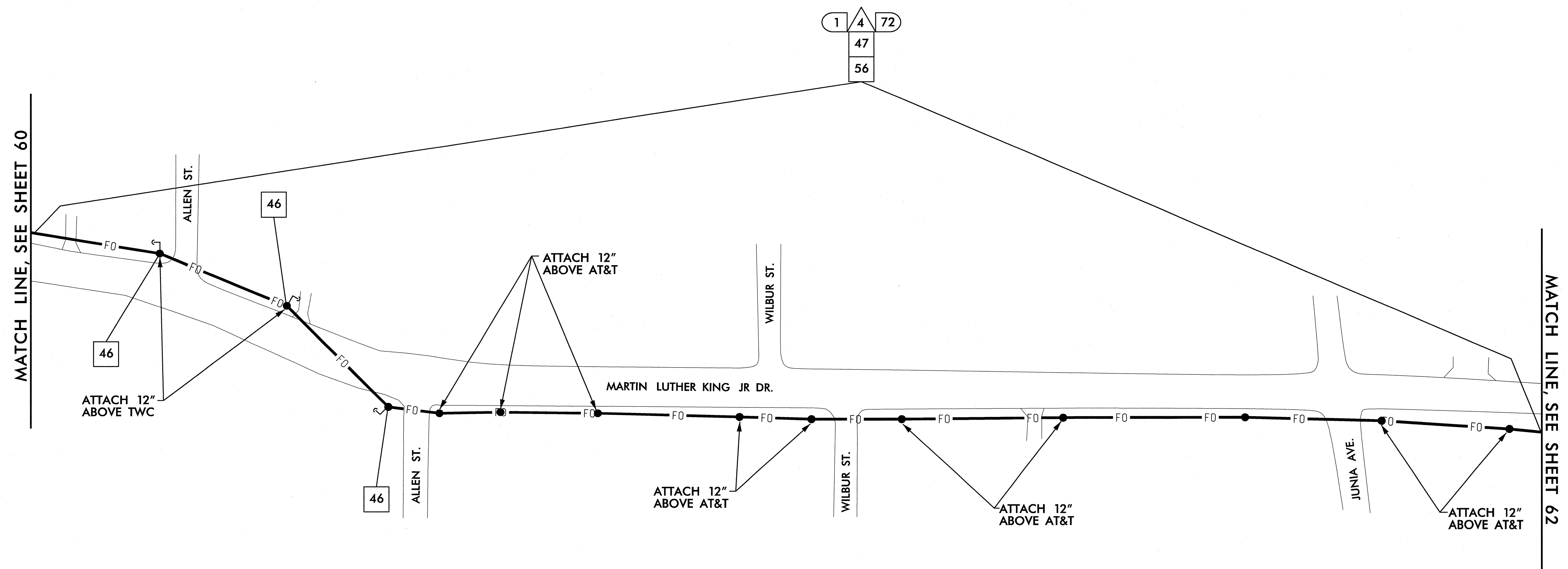

NOTE:
ATTACH 40" BELOW POWER, FRONT SIDE
OF POLE, UNLESS OTHERWISE NOTED

1/25/2011 11:47:03 AM jerry.cross k:\real_tproj_its\011086188-us 52_its (u-2826B)\plan\sh1 061.dgn

PLANS PREPARED IN THE OFFICE OF:

Kimley-Horn and Associates, Inc.
P.O. Box 33068
Raleigh N.C. 27636-3068
(919) 677-2000
N.C. License # F-0102

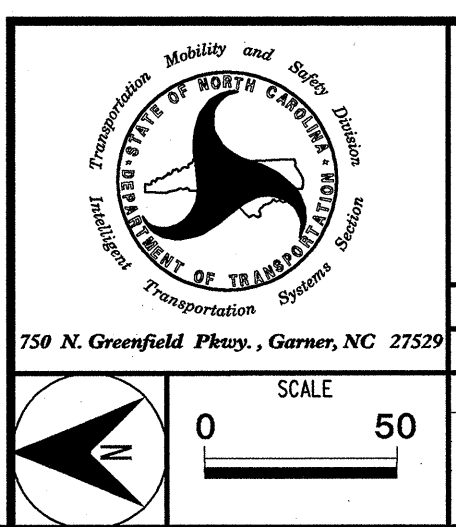

U-2826B	
CABLE ROUTING PLAN SHEET	
DIVISION 9 FORSYTH COUNTY WINSTON SALEM	
PLAN DATE: JANUARY 2011	REVIEWED BY:
PREPARED BY: J. Cross	REVIEWED BY: S. Privette
REVISIONS	INIT. DATE

SEAL

STEPHANIE B. PRIVETTE
ENGINEER
1-25-11
DATE
CAD/Flanagan

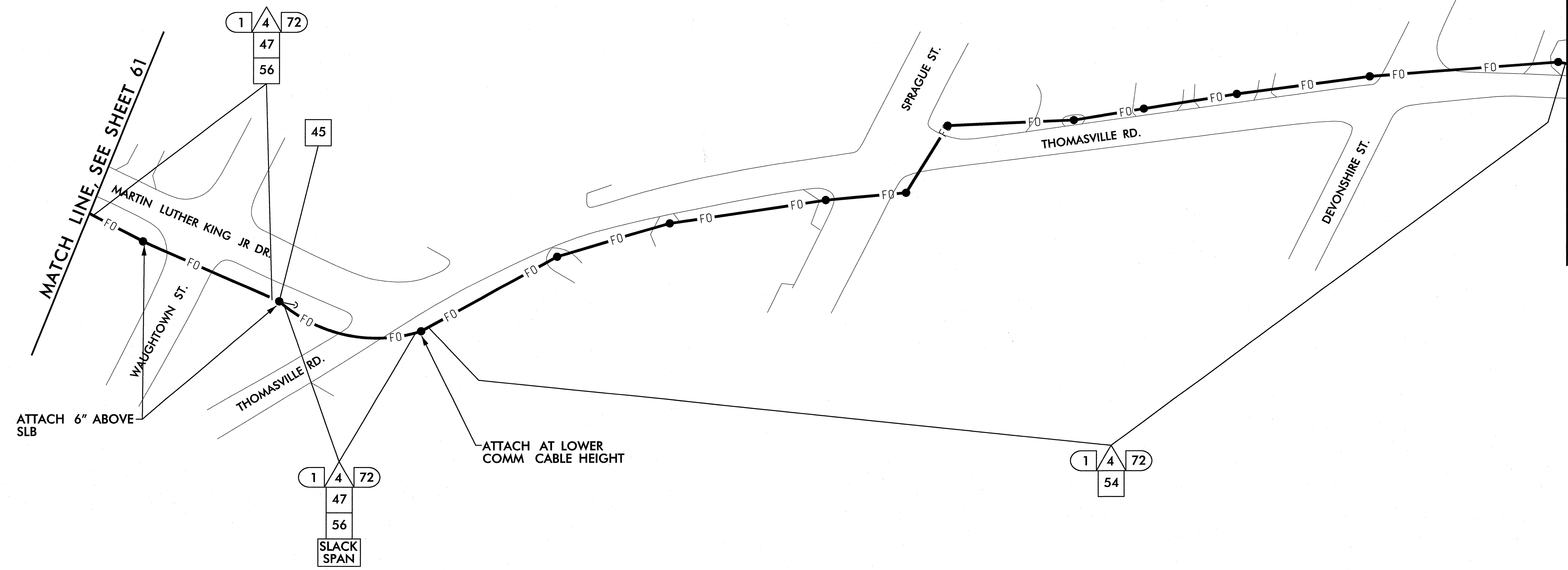

ATTACH 6" ABOVE SLB

ATTACH AT LOWER COMM CABLE HEIGHT

NOTE:
ATTACH 40" BELOW POWER, FRONT SIDE OF POLE, UNLESS OTHERWISE NOTED

k:\ncl\proj\its\11-147-04\11-147-04.dwg
 1/25/2011 11:47:04 AM jerry.cross

PLANS PREPARED IN THE OFFICE OF:

Kimley-Horn and Associates, Inc.
 P.O. Box 33068
 Raleigh, N.C. 27636-3068
 (919) 677-2000
 N.C. License # F-0102



U-2826B	
CABLE ROUTING PLAN SHEET	
DIVISION 9 FORSYTH COUNTY WINSTON SALEM	
PLAN DATE: JANUARY 2011	REVIEWED BY:
PREPARED BY: J. Cross	REVIEWED BY: S. Privette
SCALE	0 50
REVISIONS	INIT. DATE

SEAL

SIGNATURE DATE 1-25-11
 CADD Filename

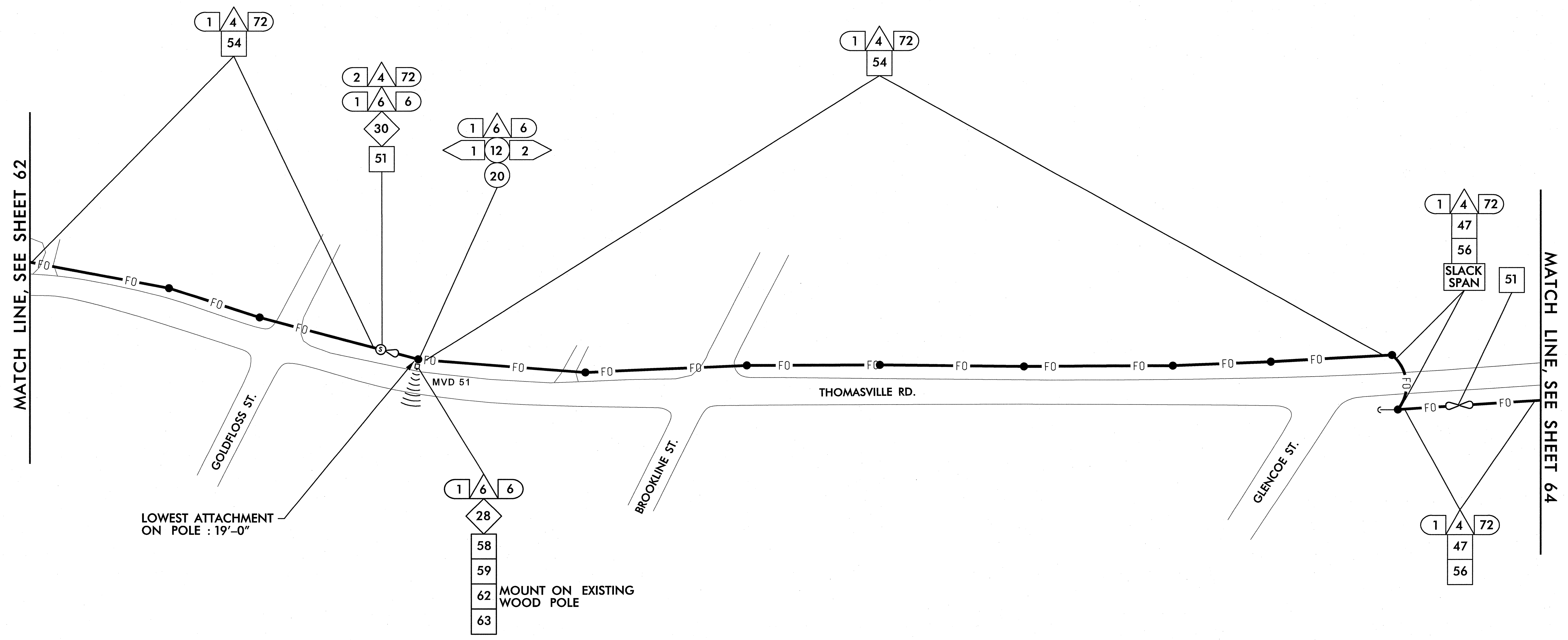

MATCH LINE, SEE SHEET 62

MATCH LINE, SEE SHEET 64

LOWEST ATTACHMENT ON POLE : 19'-0"

MOUNT ON EXISTING WOOD POLE

NOTE:
ATTACH 40" BELOW POWER, FRONT SIDE OF POLE, UNLESS OTHERWISE NOTED

1/25/2011 11:47:05 AM jerry.cross k:\val_tproj_its\01086158-us 52_its (u-2826b)\plan\sh63.dwg

PLANS PREPARED IN THE OFFICE OF:

Kimley-Horn and Associates, Inc.
P.O. Box 33068
Raleigh, N.C. 27636-3068
(919) 677-2000
N.C. License # F-0102

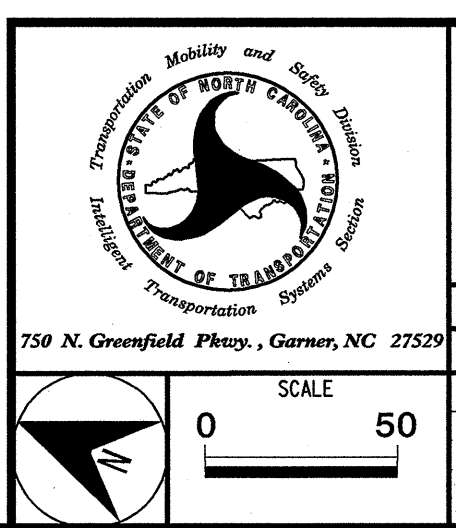

U-2826B	
CABLE ROUTING PLAN SHEET	
DIVISION 9 FORSYTH COUNTY WINSTON SALEM	
PLAN DATE: JANUARY 2011	REVIEWED BY:
PREPARED BY: J. Cross	REVIEWED BY: S. Privette
REVISIONS	INIT. DATE

SEAL

STEPHANIE B. PRIVETTE
ENGINEER
DATE: 1-25-11
CADD Filename:

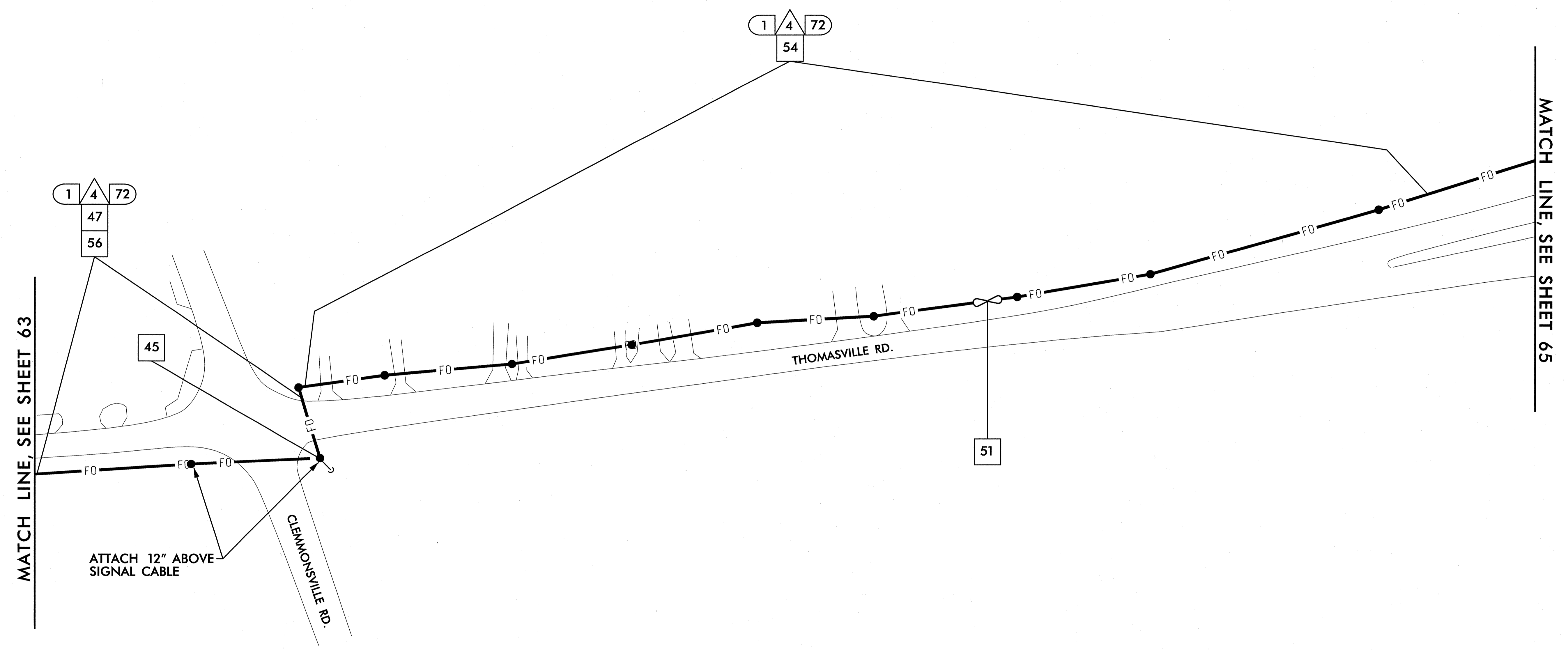

ATTACH 12" ABOVE
SIGNAL CABLE

NOTE:
ATTACH 40" BELOW POWER, FRONT SIDE
OF POLE, UNLESS OTHERWISE NOTED

1/25/2011 11:47:06 AM jerry.cross k:\na1_tproj_its\01056158-us 52_its (u-2826B)\plan\sh64.dgn

PLANS PREPARED IN
THE OFFICE OF:

**Kimley-Horn
and Associates, Inc.**
P.O. Box 33068
Raleigh, N.C. 27636-3068
(919) 677-2000
N.C. License # F-0102

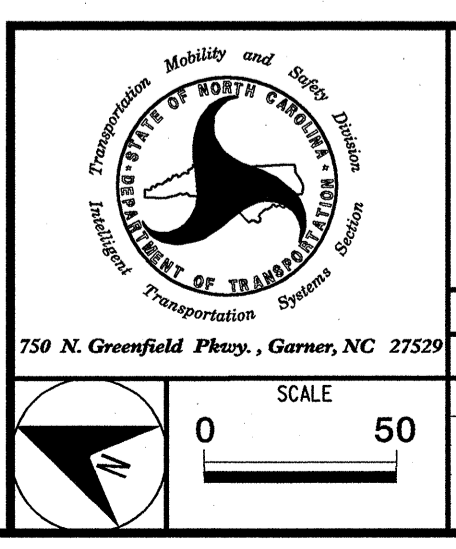

U-2826B	
CABLE ROUTING PLAN SHEET	
DIVISION 9 FORSYTH COUNTY WINSTON SALEM	
PLAN DATE: JANUARY 2011	REVIEWED BY:
PREPARED BY: J. Cross	REVIEWED BY: S. Privette
REVISIONS	INIT. DATE

SEAL

SIGNATURE: *Stephanie B. Privette* DATE: 1-25-11
CADD Filename:

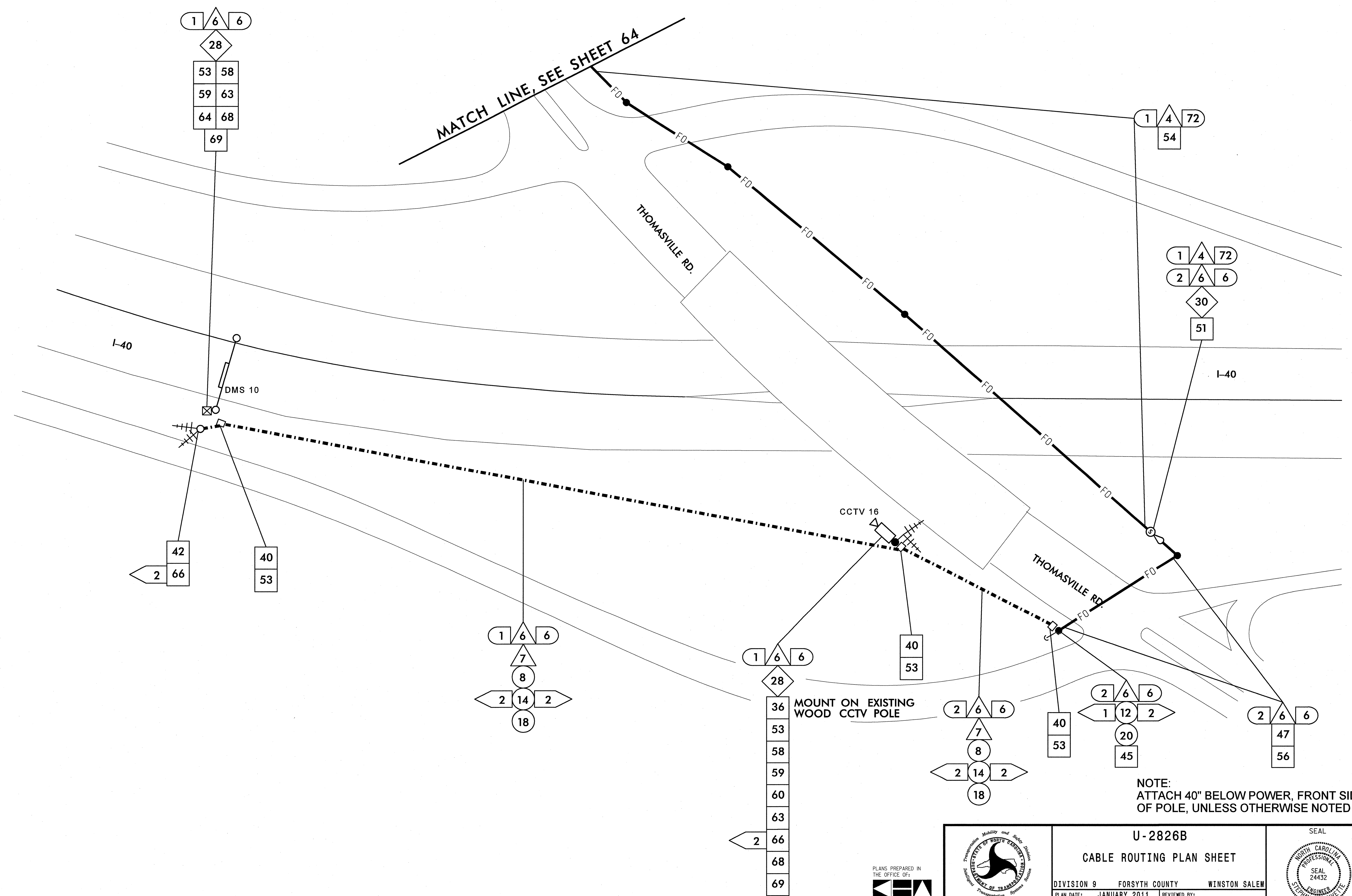

k:\real_tproj_its\110806158-us_02_11s (U-2826B)\plan\SHt 065.dgn
 11:47:07 AM Jerry Cross
 1/25/2011

PLANS PREPARED IN THE OFFICE OF:

Kimley-Horn and Associates, Inc.
 P.O. Box 33068
 Raleigh, N.C. 27636-3068
 (919) 677-2000
 N.C. License # F-0102

750 N. Greenfield Pkwy., Garner, NC 27529
 SCALE: 0 50

U-2826B	
CABLE ROUTING PLAN SHEET	
DIVISION 9 FORSYTH COUNTY WINSTON SALEM	
PLAN DATE: JANUARY 2011	REVIEWED BY:
PREPARED BY: J. CROSS	REVIEWED BY: S. Privette
REVISIONS	INIT. DATE

SEAL

SIGNATURE: *Stephanie B. Privette* DATE: 1-25-11
 CADD Filename:

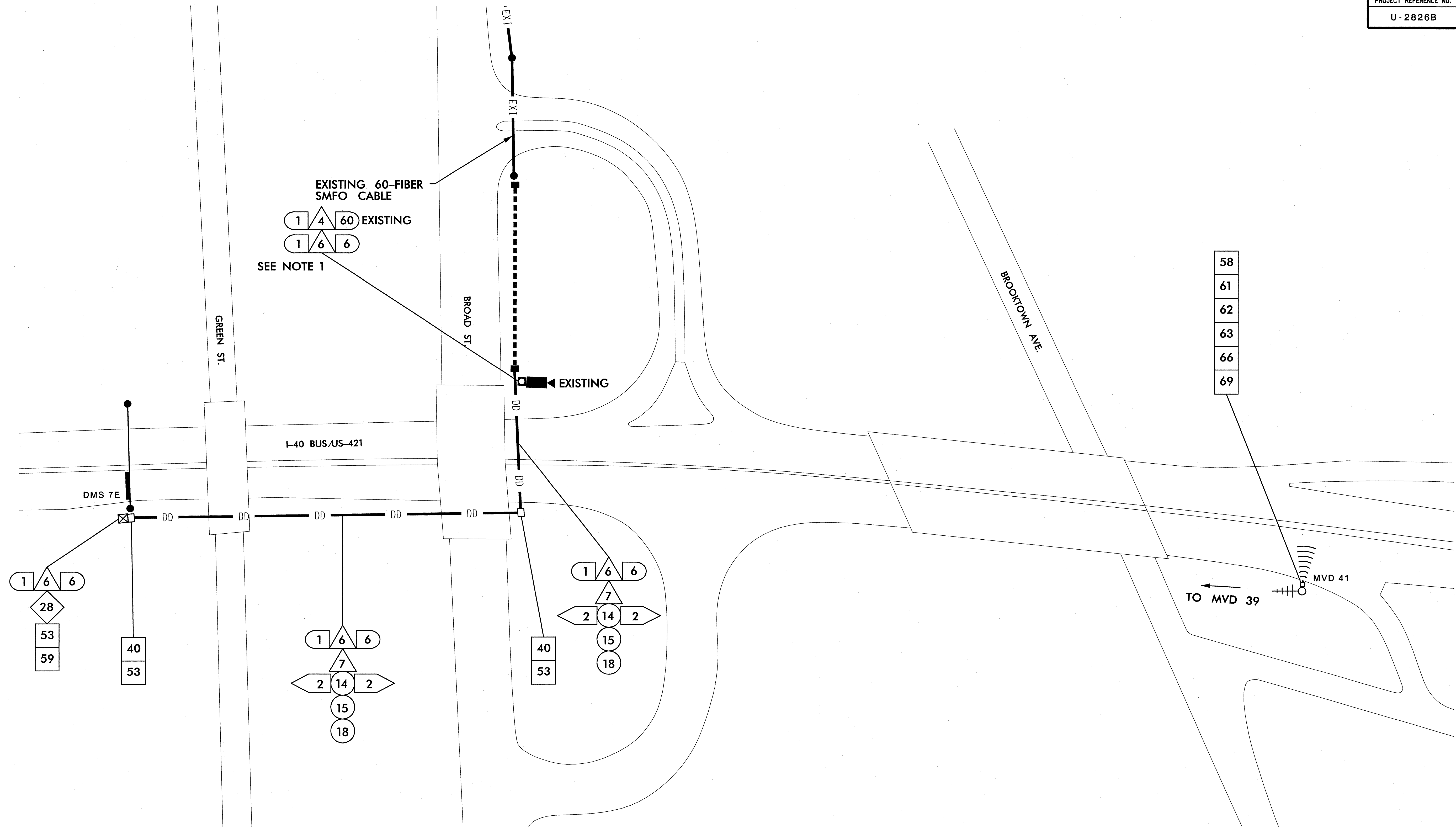

1/25/2011 11:47:08 AM jerry.cross
 k:\real_projo_its\01086158-us 52_its (u-2826b)\plam\shd 066.dgn

NOTE:
 1. JUMPER 6-FIBER DROP CABLE TO DMS-7E
 IN EXISTING CCTV CABINET

PLANS PREPARED IN
 THE OFFICE OF:

**Kimley-Horn
 and Associates, Inc.**
 P.O. Box 33068
 Raleigh N.C. 27636-3068
 (919) 677-2000
 N.C. License # F-0102

750 N. Greenfield Pkwy., Garner, NC 27529

U-2826B	
CABLE ROUTING PLAN SHEET	
DIVISION 9 FORSYTH COUNTY WINSTON SALEM	
PLAN DATE: JANUARY 2011	REVIEWED BY:
PREPARED BY: J. Cross	REVIEWED BY: S. Privette
REVISIONS	INIT. DATE

SEAL

STEPHANIE B. PRIVETTE
 ENGINEER
 STATE OF NORTH CAROLINA
 License No. 24432

Signature: *Stephanie B. Privette* DATE: 1-26-11
 CADD Filename:

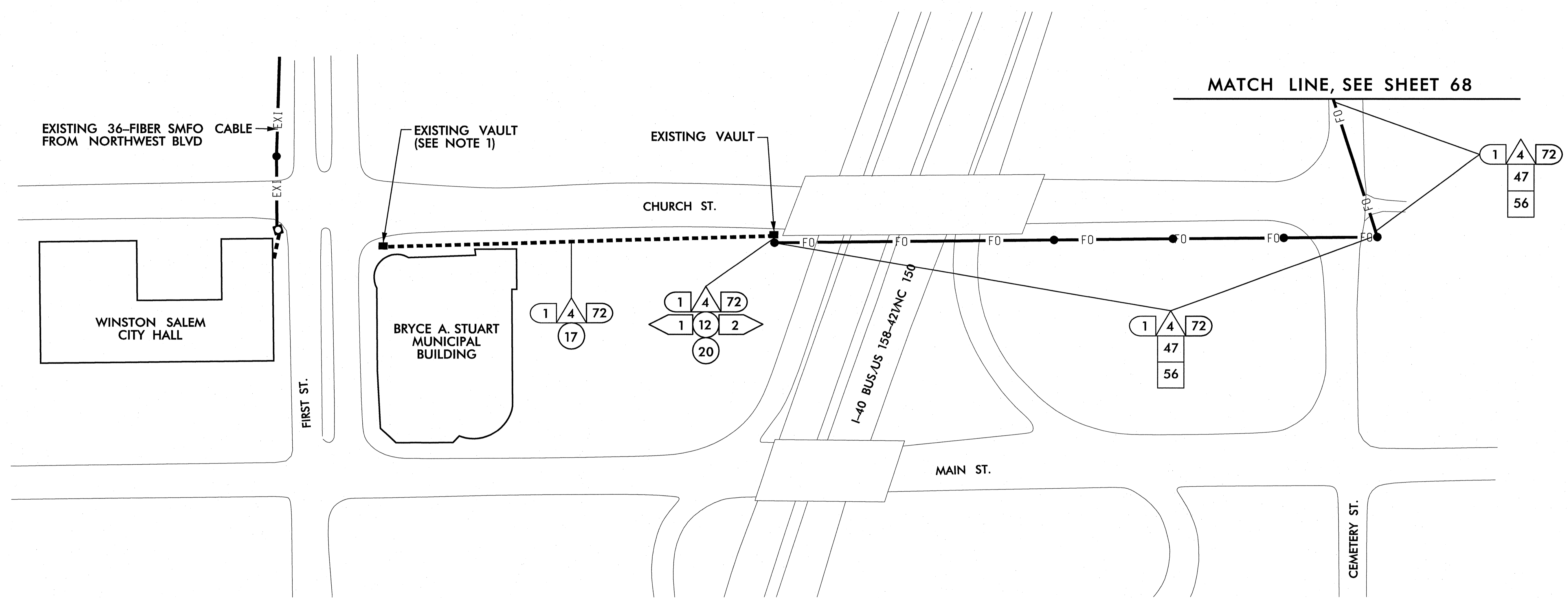

NOTE:
 1. ROUTE NEW 72-FIBER CABLE FROM VAULT INTO BRYCE A. STUART MUNICIPAL BUILDING ALONG SAME ROUTE AS EXISTING 24-FIBER CABLE ENTERING BUILDING FROM VAULT. ROUTE CABLE TO THIRD FLOOR SERVER ROOM. TERMINATE 4 FIBERS IN CABLE ON NEW 6-FIBER PATCH PANEL. CAP AND SEAL UNUSED FIBERS IN CABLE. INSTALL JUMPERS BETWEEN PATCH PANELS. SEE SPLICE DIAGRAMS FOR BRYCE A. STUART MUNICIPAL BUILDING AND WINSTON SALEM TRANSIT CENTER FOR TERMINATION AND JUMPER DETAILS.

1/26/2011 10:12:16 AM jerry.cross k:\ncl\proj_its\01038558-us_52_its\0-2826B\plan\sh67.dwg

PLANS PREPARED IN THE OFFICE OF:

Kimley-Horn and Associates, Inc.
 P.O. Box 33068
 Raleigh, N.C. 27636-3068
 (919) 677-2000
 N.C. License # F-0102

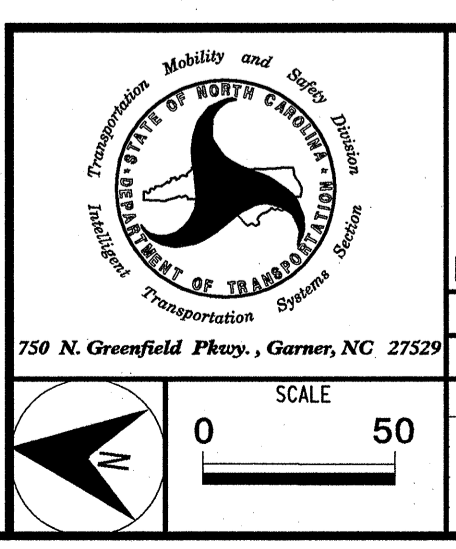

U-2826B	
CABLE ROUTING PLAN SHEET	
DIVISION 9 FORSYTH COUNTY WINSTON SALEM	
PLAN DATE: JANUARY 2011	REVIEWED BY:
PREPARED BY: J. Cross	REVIEWED BY: S. Privette
REVISIONS	INIT. DATE

SEAL

 SIGNATURE: *Stephanie B. Privette* DATE: 1.25.11
 CADD Filename:

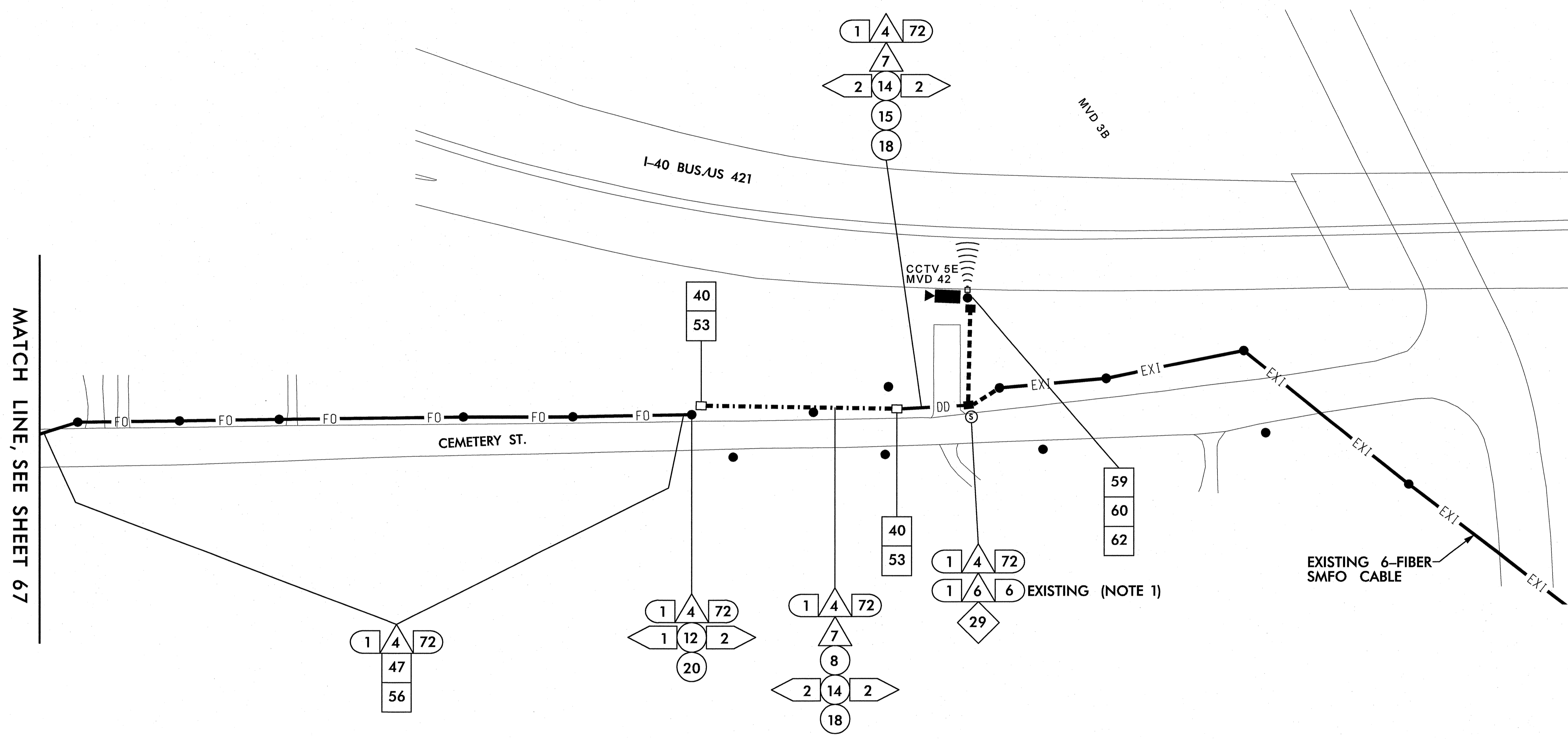

NOTE:
 1. SPLICE 72-FIBER CABLE INTO EXISTING 6-FIBER CABLE.
 RETAIN 6-FIBER CABLE FROM JUNCTION BOX TO CCTV CABINET.

1/26/2011 2:58:00 PM jerry.cross k:\na1_tproj_tba\011086158-us 52_its (u-2826b)\plan\sh1 088.dgn

PLANS PREPARED IN THE OFFICE OF:

Kimley-Horn and Associates, Inc.
 P.O. Box 33068
 Raleigh N.C. 27636-3068
 (919) 677-2000
 N.C. License # F-0102

750 N. Greenfield Pkwy., Garner, NC 27529

U-2826B	
CABLE ROUTING PLAN SHEET	
DIVISION 9 FORSYTH COUNTY WINSTON SALEM	
PLAN DATE: JANUARY 2011	REVIEWED BY:
PREPARED BY: J. Cross	REVIEWED BY: S. Privette
REVISIONS	INIT. DATE

SEAL

DATE: 1-26-11
 CAD: Filenames

(A)

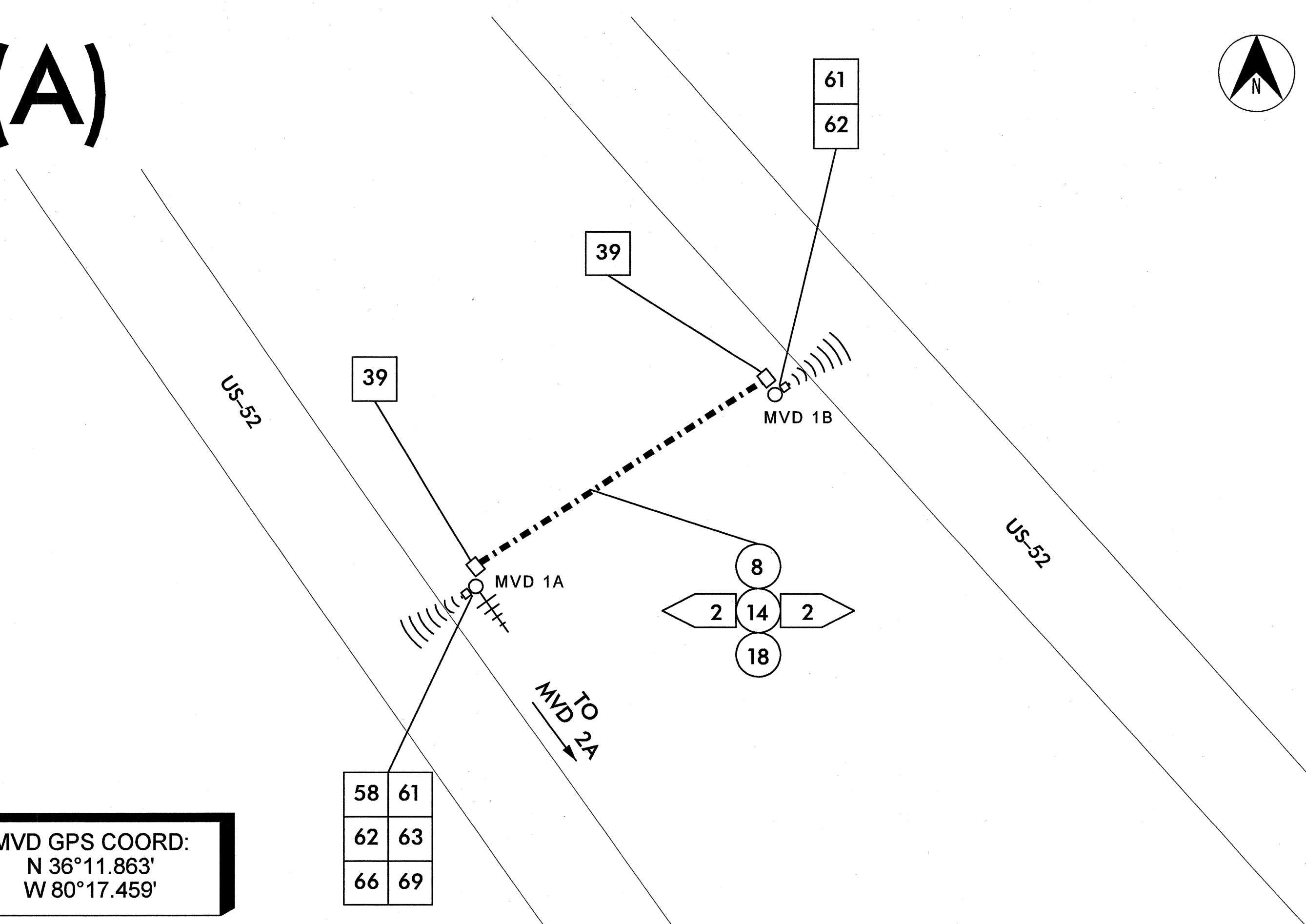

MVD GPS COORD:
N 36°11.863'
W 80°17.459'

58	61
62	63
66	69

(B)

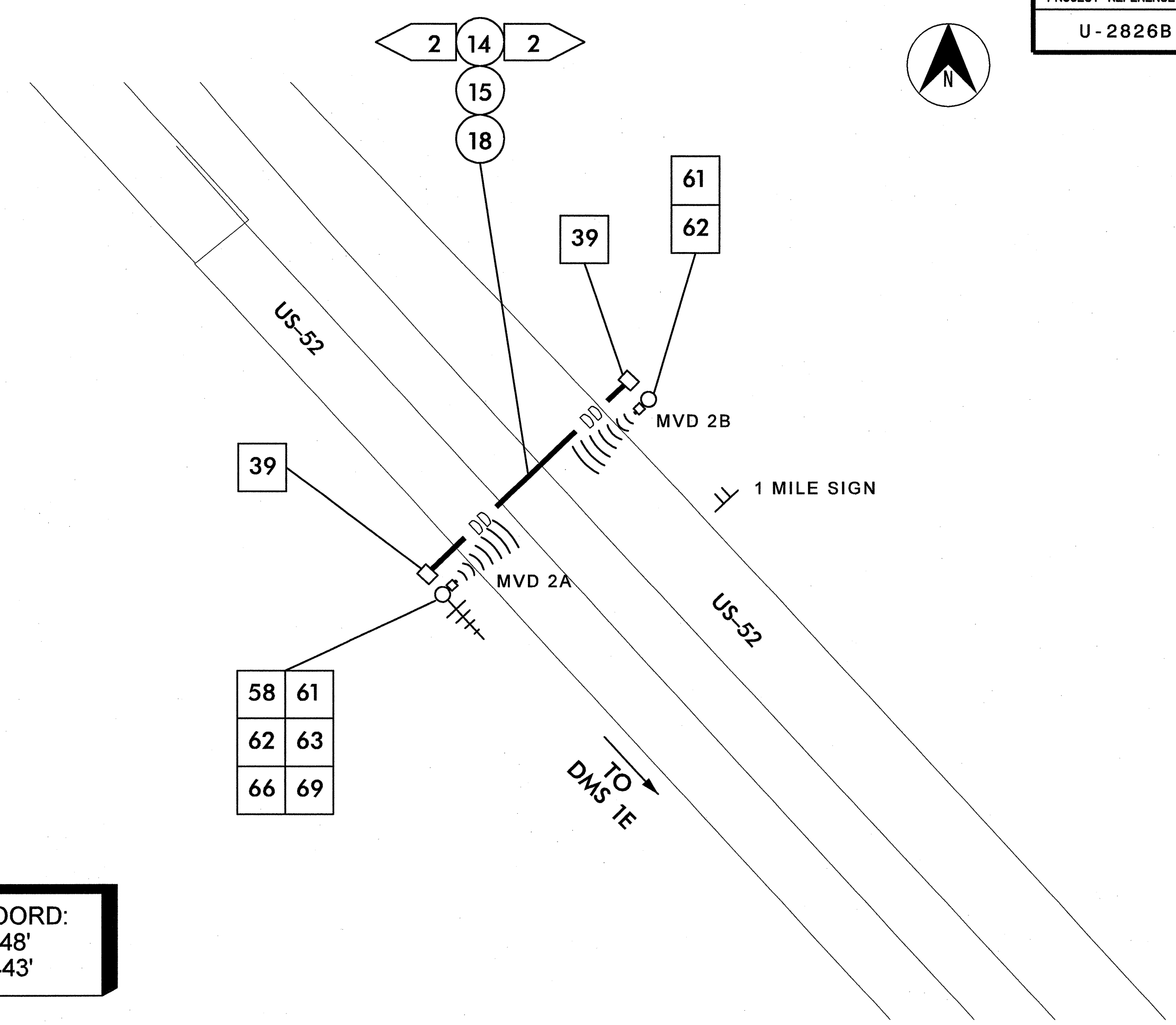

MVD GPS COORD:
N 36°11.848'
W 80°17.443'

58	61
62	63
66	69

1/25/2011 11:47:11 AM jerry.gross k:\real_tproj_its\0106168-us 52_its (u-2826B)\plan\shet 089.dgn

PLANS PREPARED IN THE OFFICE OF:

 Kimley-Horn and Associates, Inc.
 P.O. Box 33068
 Raleigh N.C. 27636-3068
 (919) 677-2000
 N.C. License # F-0102

759 N. Greenfield Pkwy., Garner, NC 27529

U-2826B			
CABLE ROUTING PLAN SHEET			
DIVISION 9		FORSYTH COUNTY	
WINSTON SALEM			
PLAN DATE:	JANUARY 2011	REVIEWED BY:	
PREPARED BY:	J. Cross	REVIEWED BY:	S. Privette
REVISIONS	INIT.	DATE	

SEAL

STEPHANIE B. PRIVETTE
 ENGINEER
 STATE OF NORTH CAROLINA
 LICENSE NO. 24432

SIGNATURE: *[Signature]* DATE: 1-25-11
 CADD Filename:

(A)

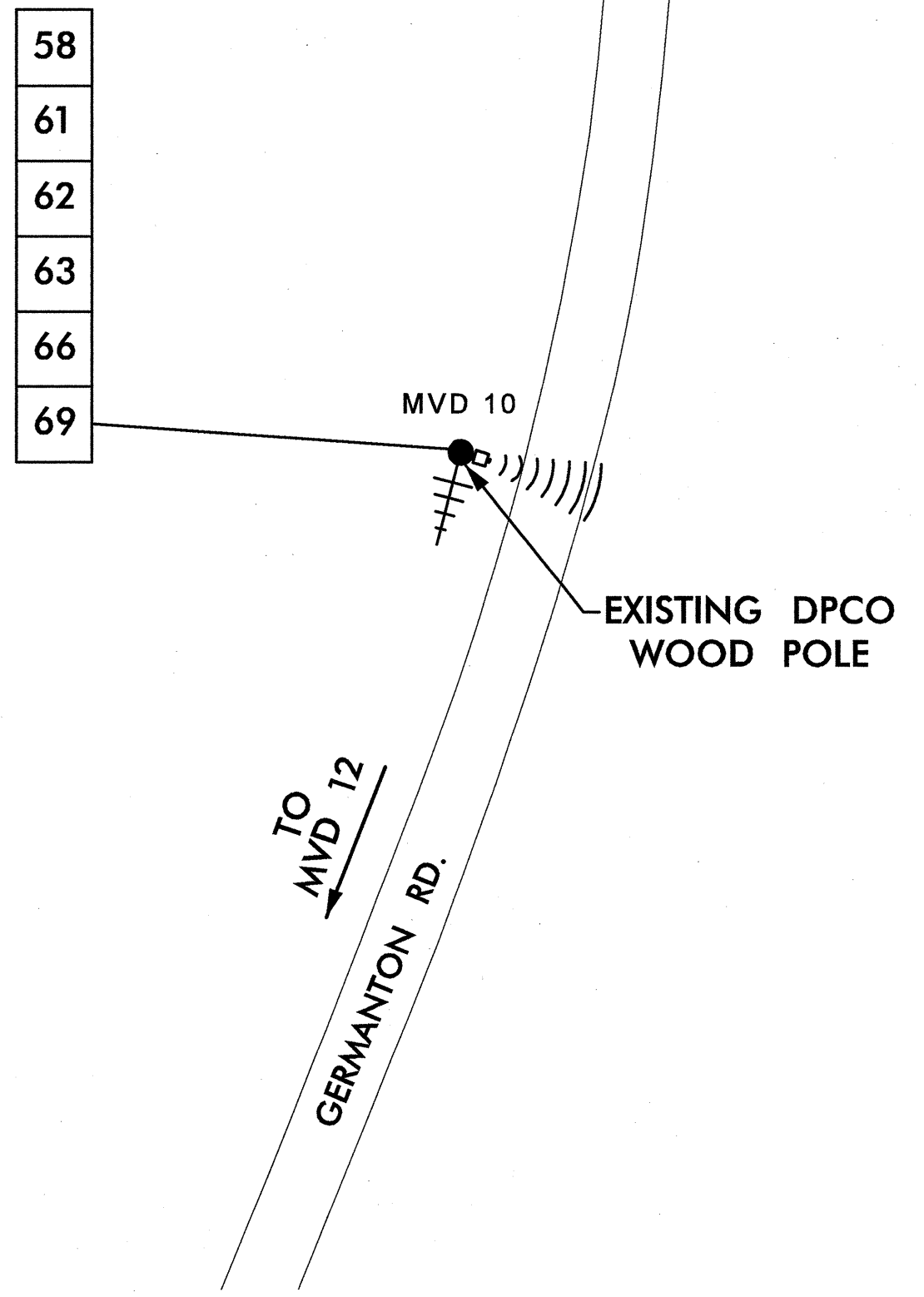

MVD GPS COORD:
N 36°10.559'
W 80°15.491'

(B)

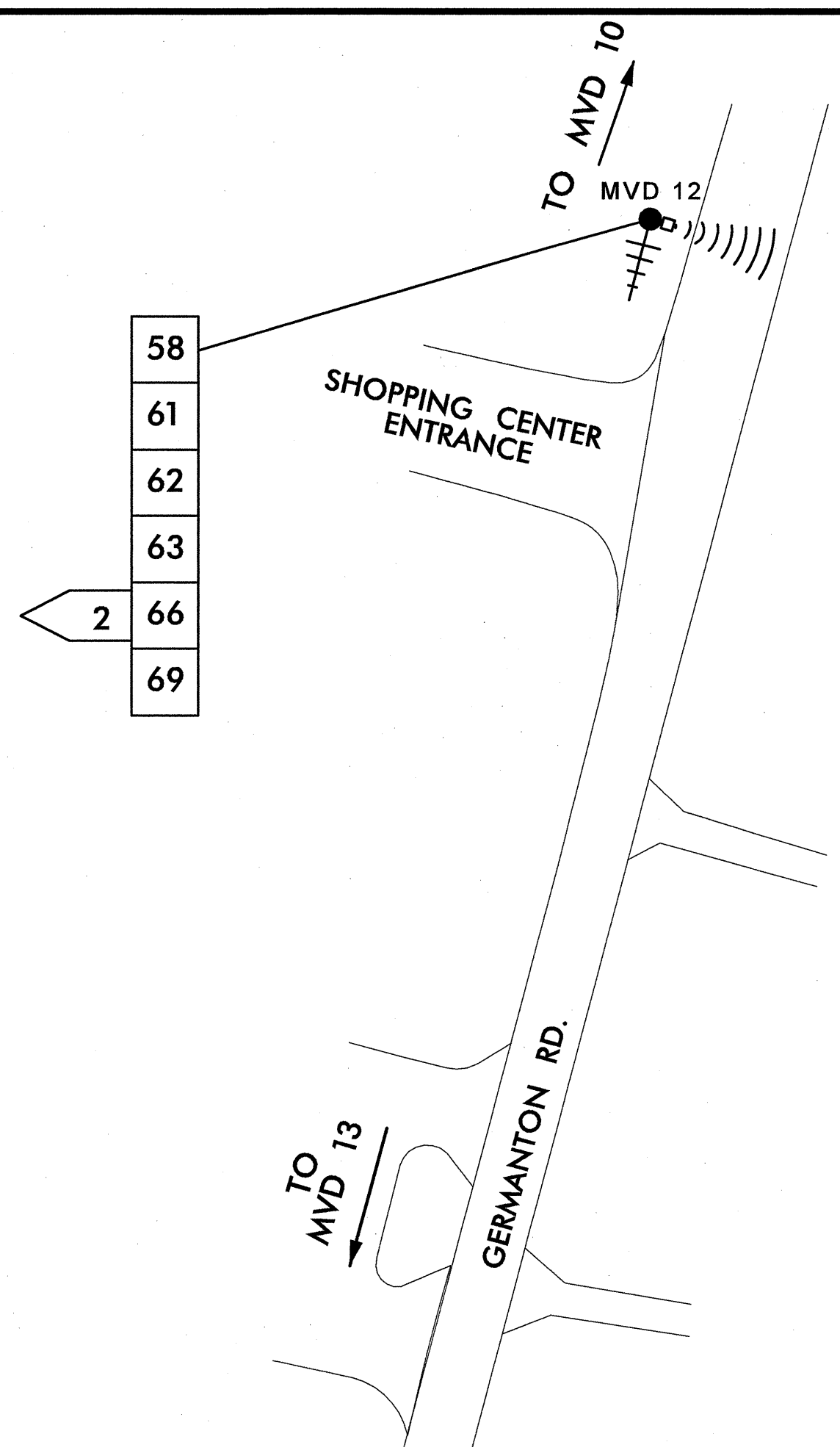

MVD GPS COORD:
N 36°10.294'
W 80°15.607'

(C)

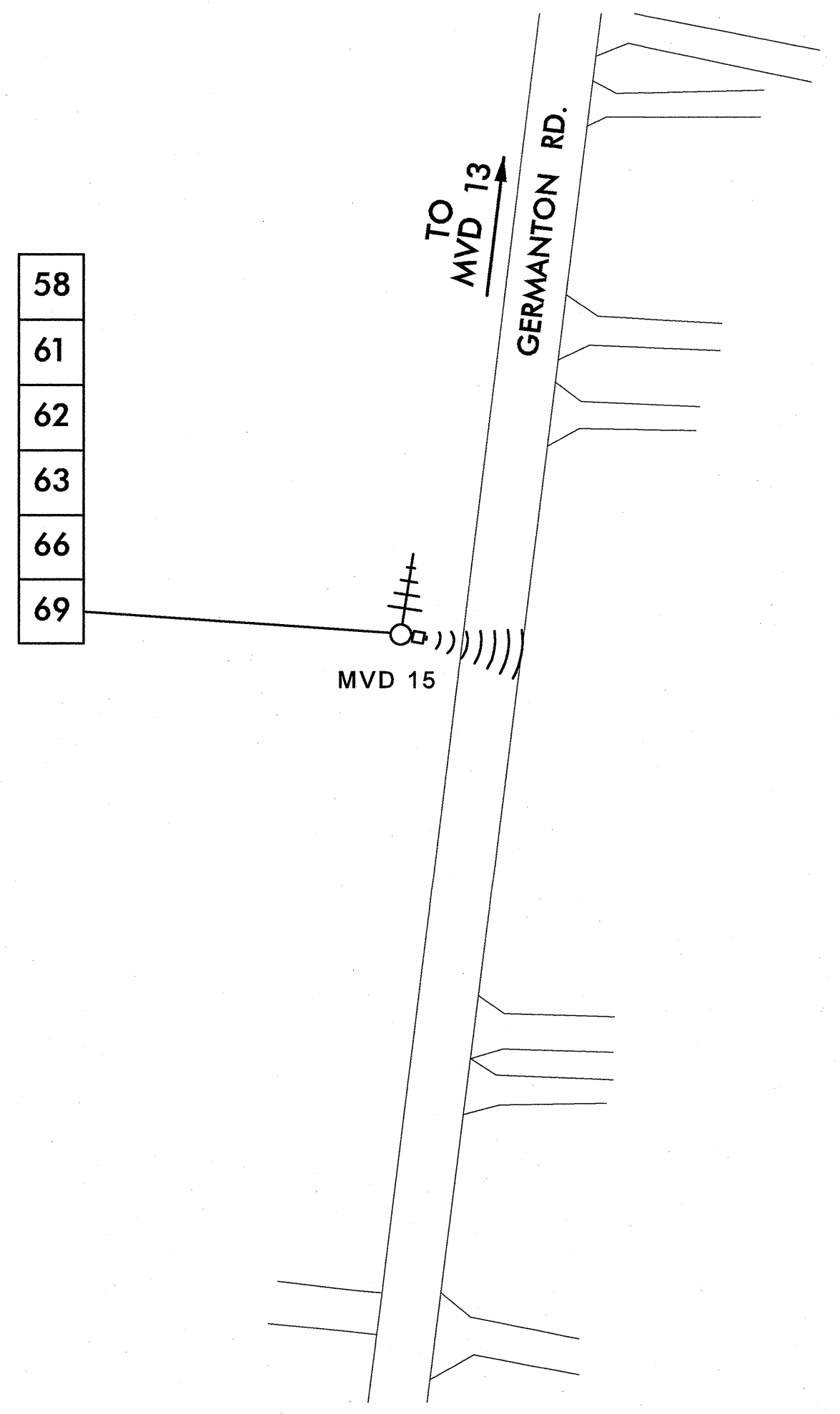

MVD GPS COORD:
N 36°12.495'
W 80°18.045'

1/25/2011 11:47:12 AM jerry.cross k:\real\proj_its\01108658-us_82_its (u-2826B)\plan\sh_070.dgn

PLANS PREPARED IN THE OFFICE OF:

 Kimley-Horn and Associates, Inc.
 P.O. Box 33068
 Raleigh, N.C. 27636-3068
 (919) 677-2000
 N.C. License # F-0102

750 N. Greenfield Pkwy., Garner, NC 27529
 SCALE: 0 50

U-2826B	
CABLE ROUTING PLAN SHEET	
DIVISION 9 FORSYTH COUNTY WINSTON SALEM	
PLAN DATE: JANUARY 2011	REVIEWED BY:
PREPARED BY: J. Cross	REVIEWED BY: S. Privette
REVISIONS	INIT. DATE

SEAL

 SIGNATURE: *Stephanie B. Privette* 1.25.11
 DATE:

(A)

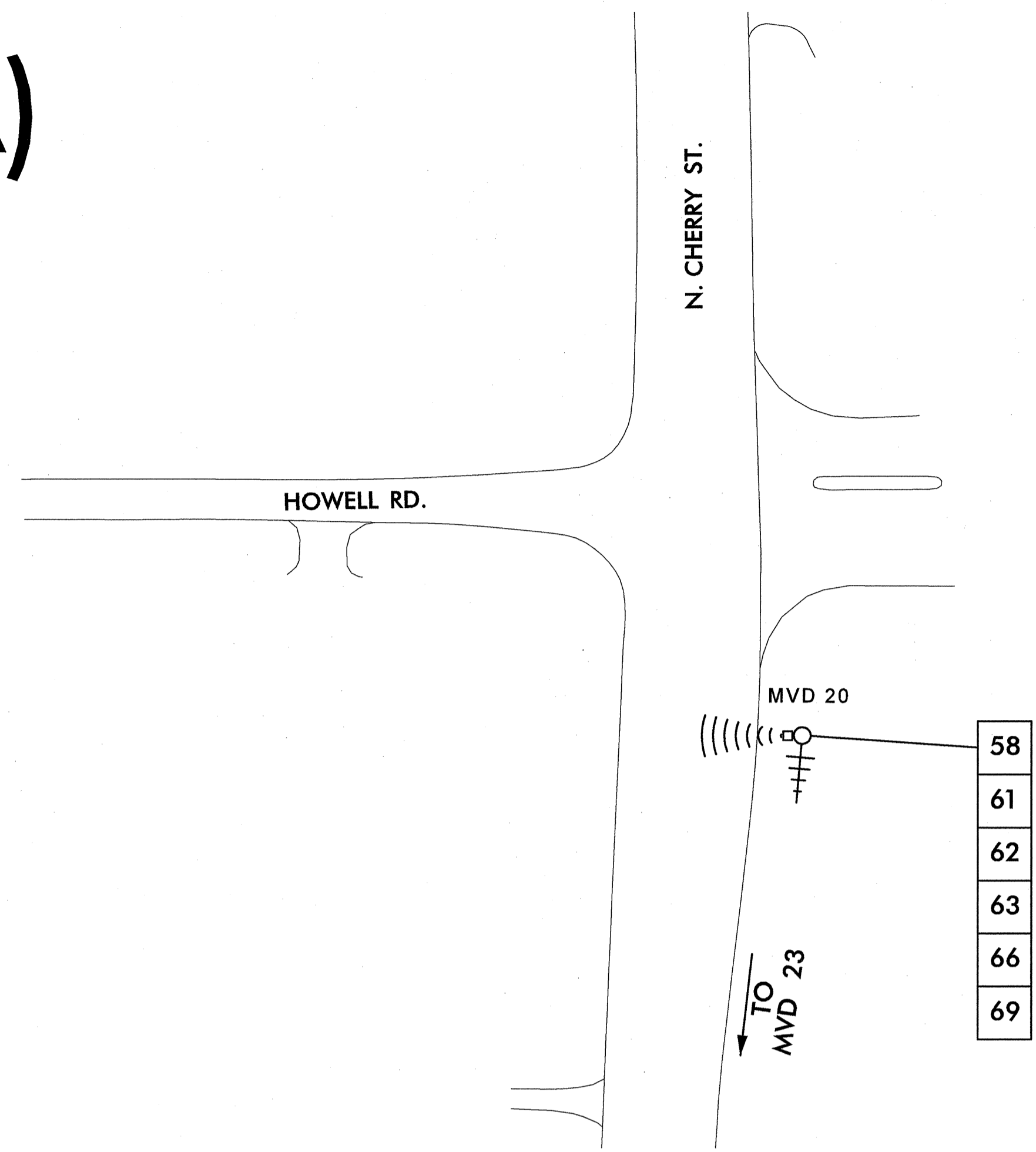

MVD GPS COORD:
N 36°10.590'
W 80°16.126'

(B)

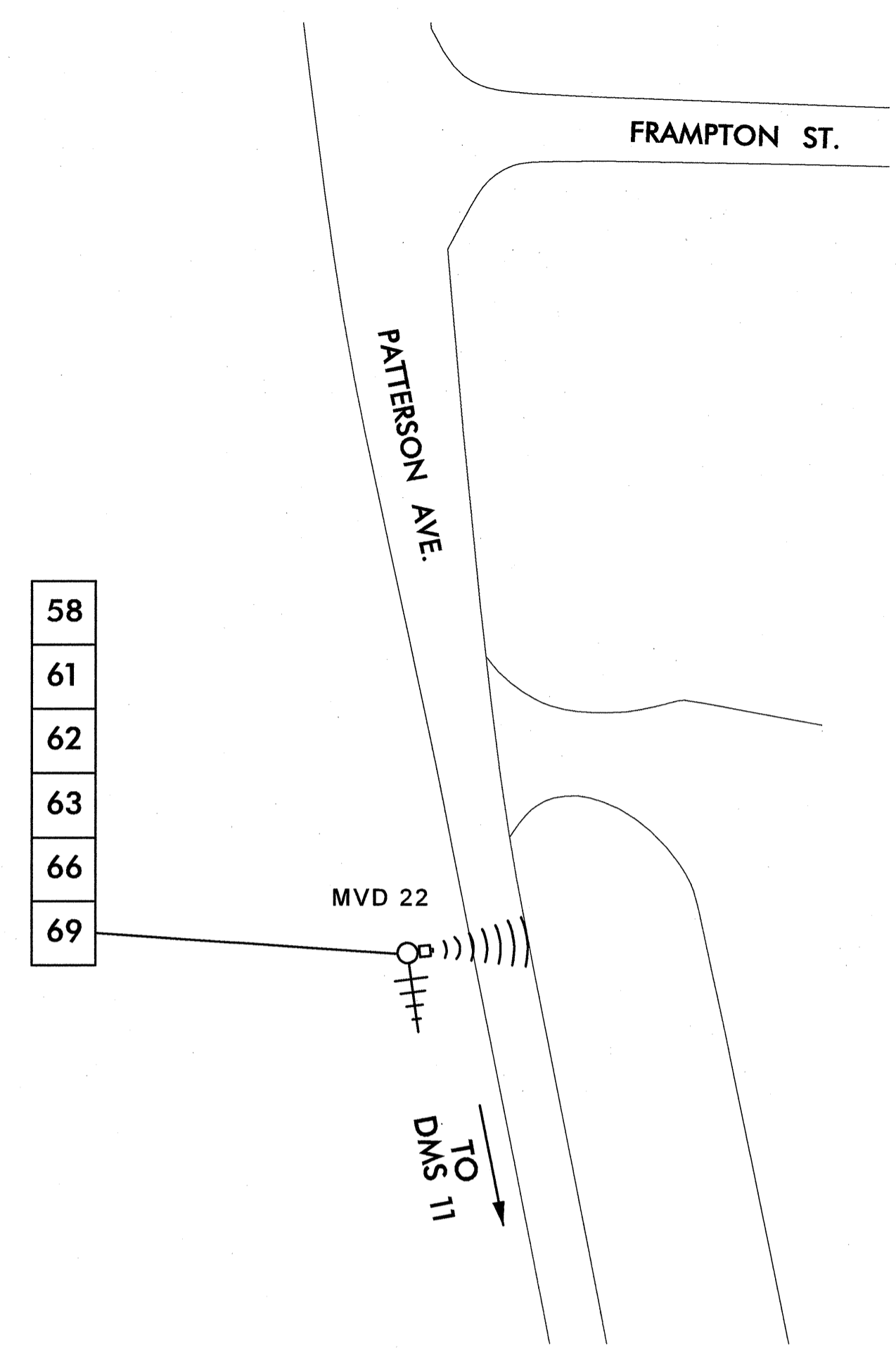

MVD GPS COORD:
N 36°08.518'
W 80°14.651'

1/25/2011 11:47:14 AM jerry.cross k:\real_tproj_its\01068158-us_52_its_u-2826b\plan\shet 071.dgn

PLANS PREPARED IN THE OFFICE OF:

Kimley-Horn and Associates, Inc.
P.O. Box 33068
Raleigh, N.C. 27636-3068
(919) 677-2000
N.C. License # F-0102

750 N. Greenfield Pkwy., Garner, NC 27529

U-2826B	
CABLE ROUTING PLAN SHEET	
DIVISION 9 FORSYTH COUNTY WINSTON SALEM	
PLAN DATE: JANUARY 2011	REVIEWED BY:
PREPARED BY: J. Cross	REVIEWED BY: S. Privette
REVISIONS	INIT. DATE

SEAL

STEPHANIE B. PRIVETTE
1-25-11
DATE

CADD Filenames

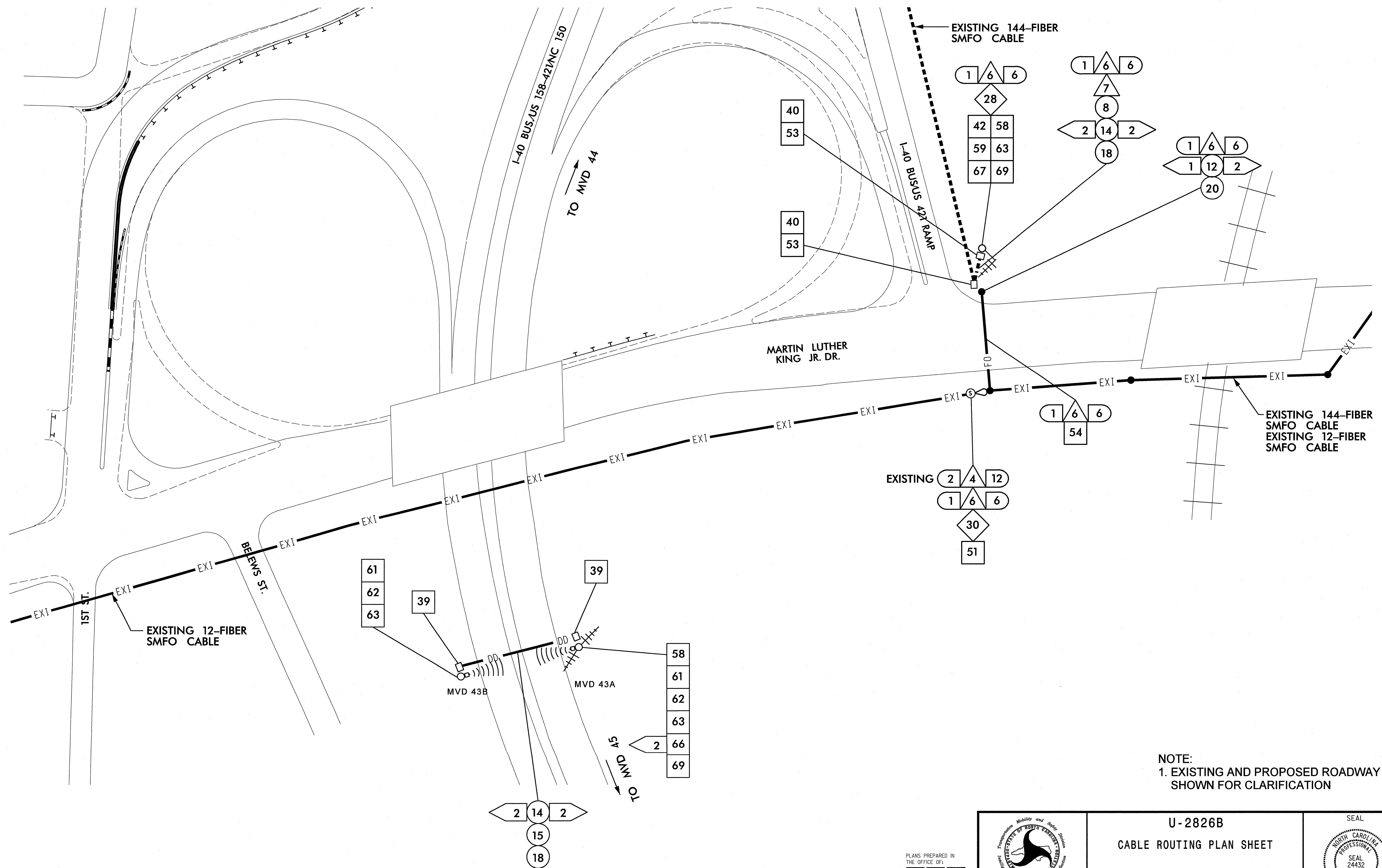

NOTE:
1. EXISTING AND PROPOSED ROADWAY SHOWN FOR CLARIFICATION

k:\nal_tproj_its\01080658-us_92_1ts (U-2826B)\plan\Shr 072.dgn
 1/25/2011 11:47:15 AM jerry.cross

PLANS PREPARED IN THE OFFICE OF:

Kimley-Horn and Associates, Inc.
 P.O. Box 33068
 Raleigh, N.C. 27636-3068
 (919) 677-2000
 N.C. License # F-0102

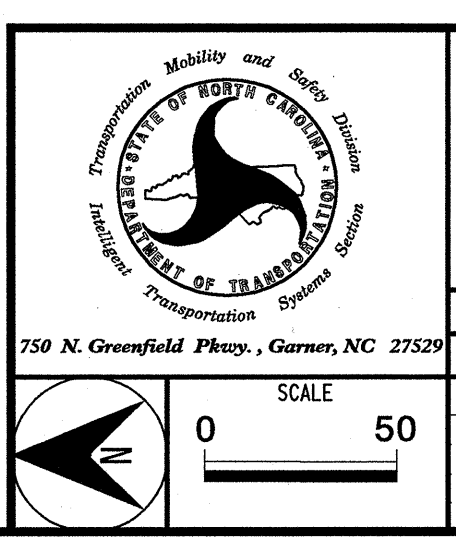

U-2826B	
CABLE ROUTING PLAN SHEET	
DIVISION 9 FORSYTH COUNTY WINSTON SALEM	
PLAN DATE: JANUARY 2011	REVIEWED BY:
PREPARED BY: J. Cross	REVIEWED BY: S. Privette
REVISIONS	INIT. DATE

SEAL

STEPHANIE B. PRIVETTE
 PROFESSIONAL ENGINEER
 STATE OF NORTH CAROLINA
 LICENSE NO. 24432

DATE: 1/25/11

CADD Filename:

(A)

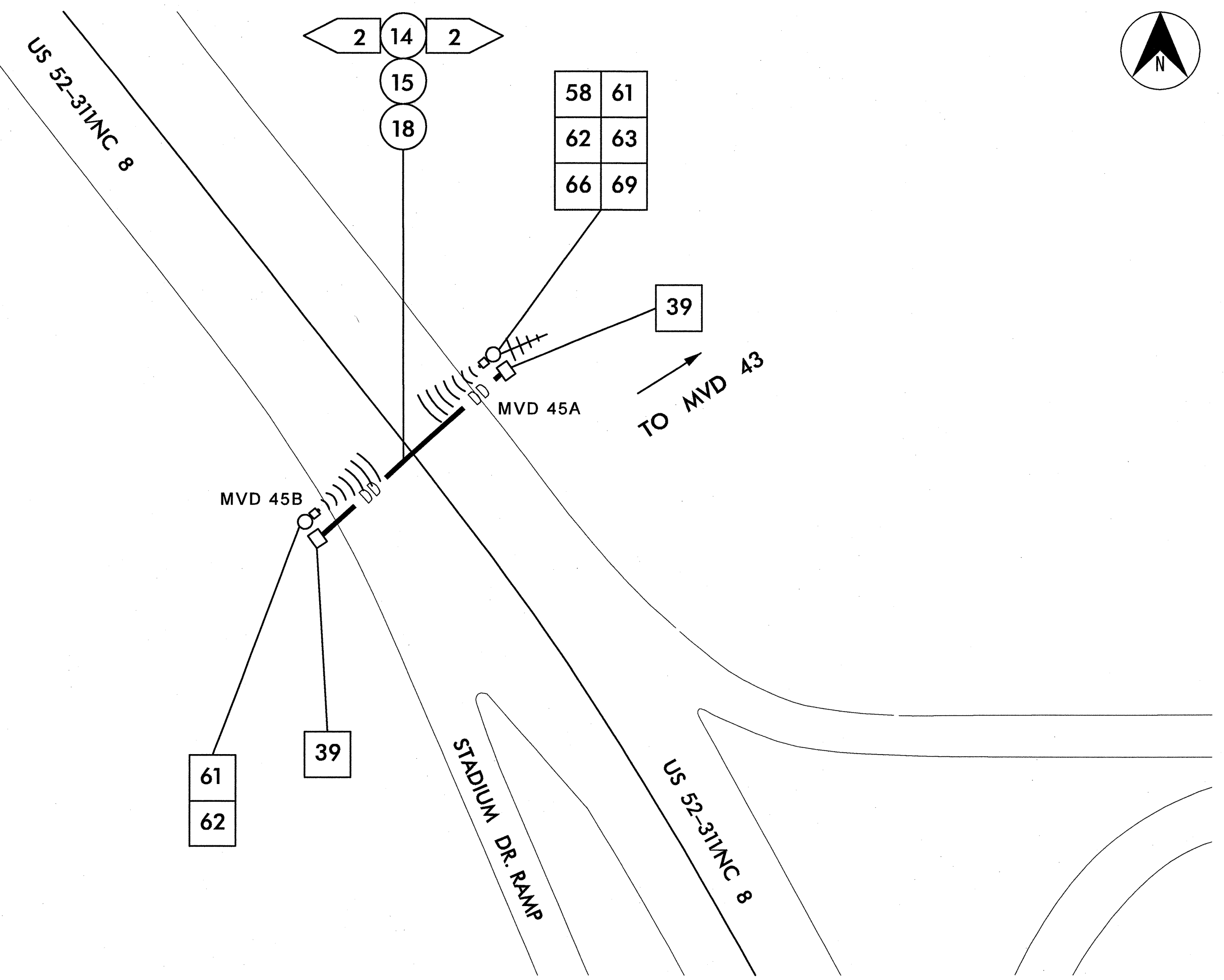

(B)

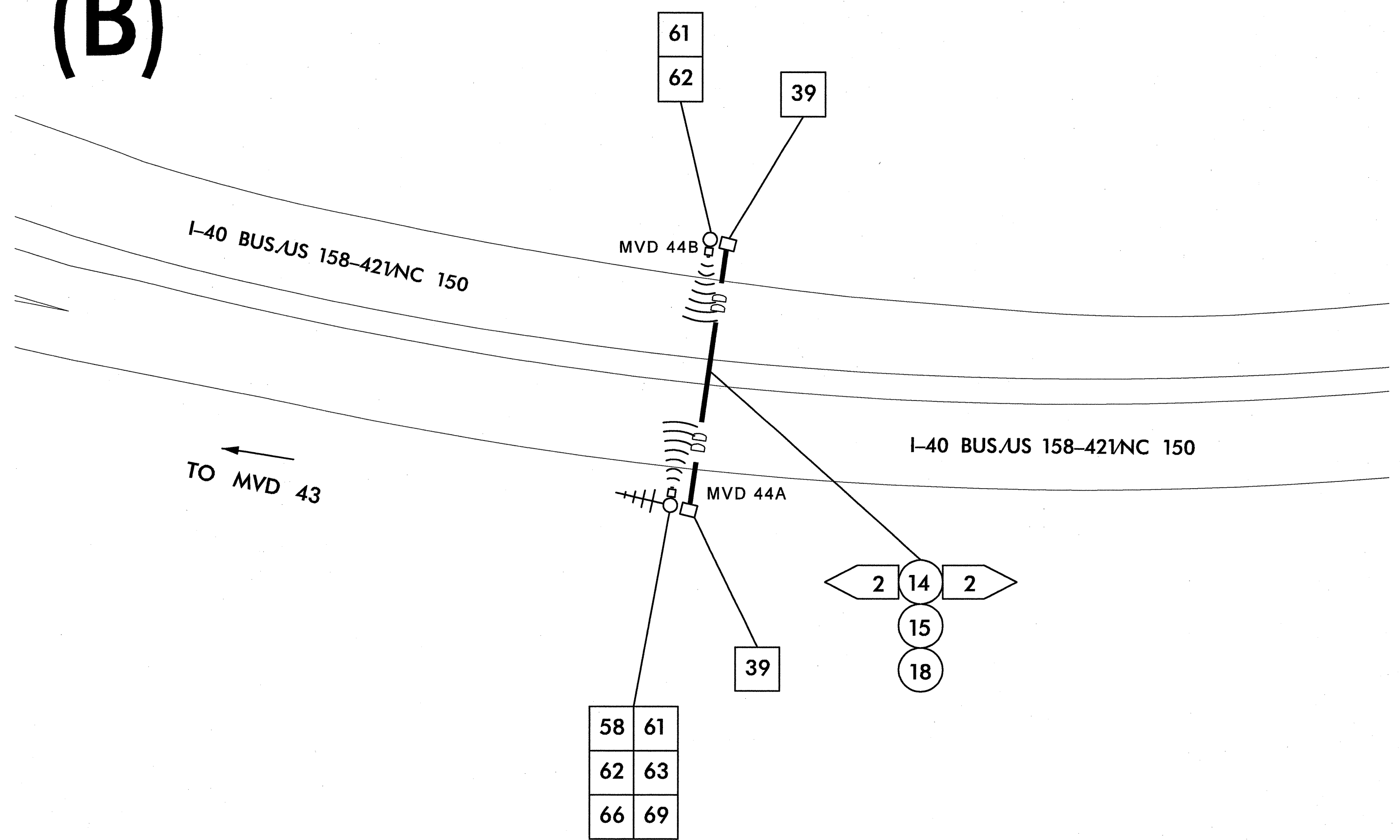

1/25/2011 11:47:16 AM jerry.cross k:\real\proj_its\01036158-us_52_1ts (U-2826B)\plan\st 073.dgn

PLANS PREPARED IN THE OFFICE OF:

Kimley-Horn and Associates, Inc.
 P.O. Box 33068
 Raleigh, N.C. 27636-3068
 (919) 677-2000
 N.C. License # F-0102

 750 N. Greenfield Pkwy., Garner, NC 27529

U-2826B	
CABLE ROUTING PLAN SHEET	
DIVISION 9 FORSYTH COUNTY WINSTON SALEM	
PLAN DATE: JANUARY 2011	REVIEWED BY:
PREPARED BY: J. Cross	REVIEWED BY: S. Privette
REVISIONS	INIT. DATE

SEAL

SIGNATURE DATE 1-26-11
 CAD/Flanomeno

(A)

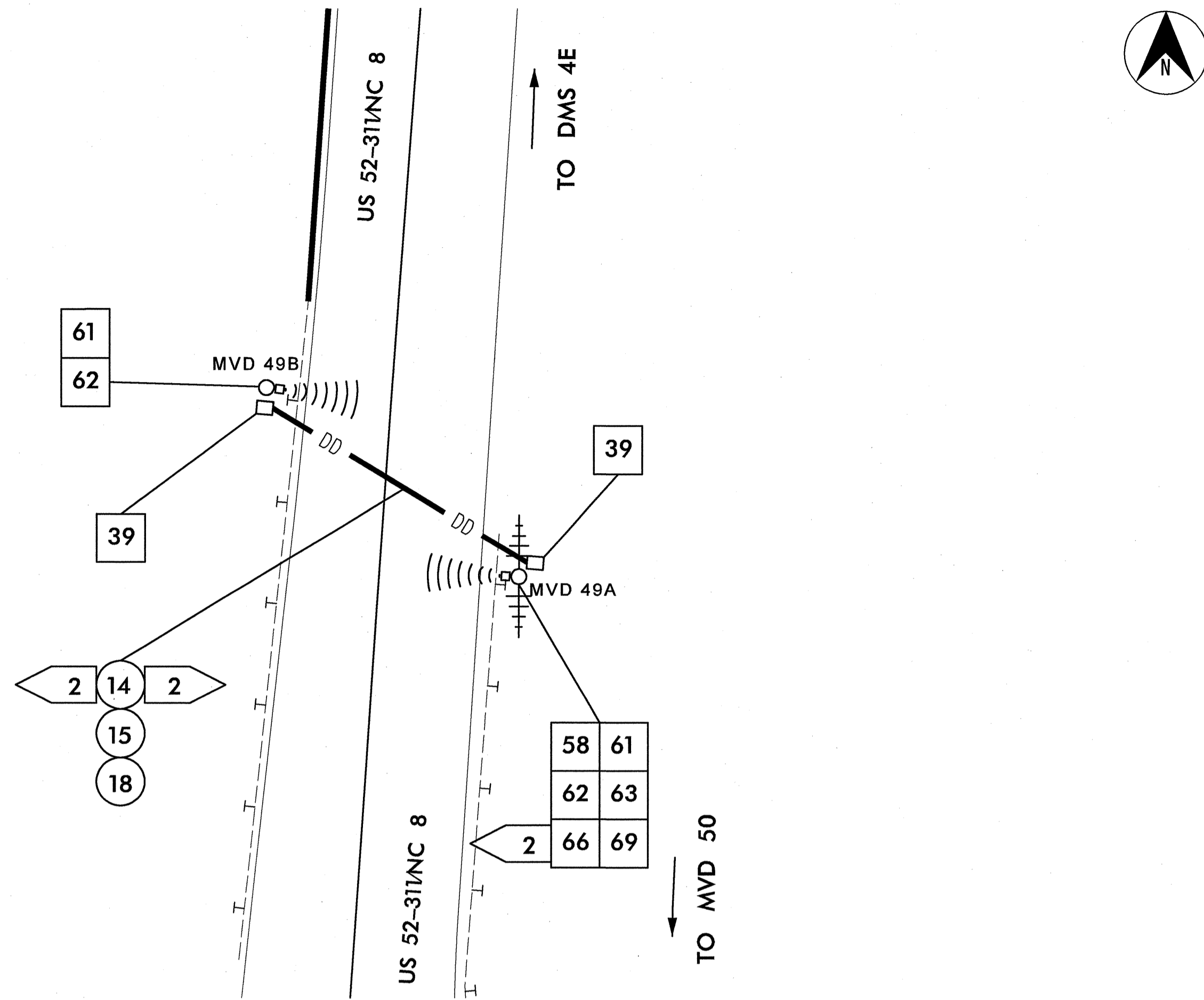

(B)

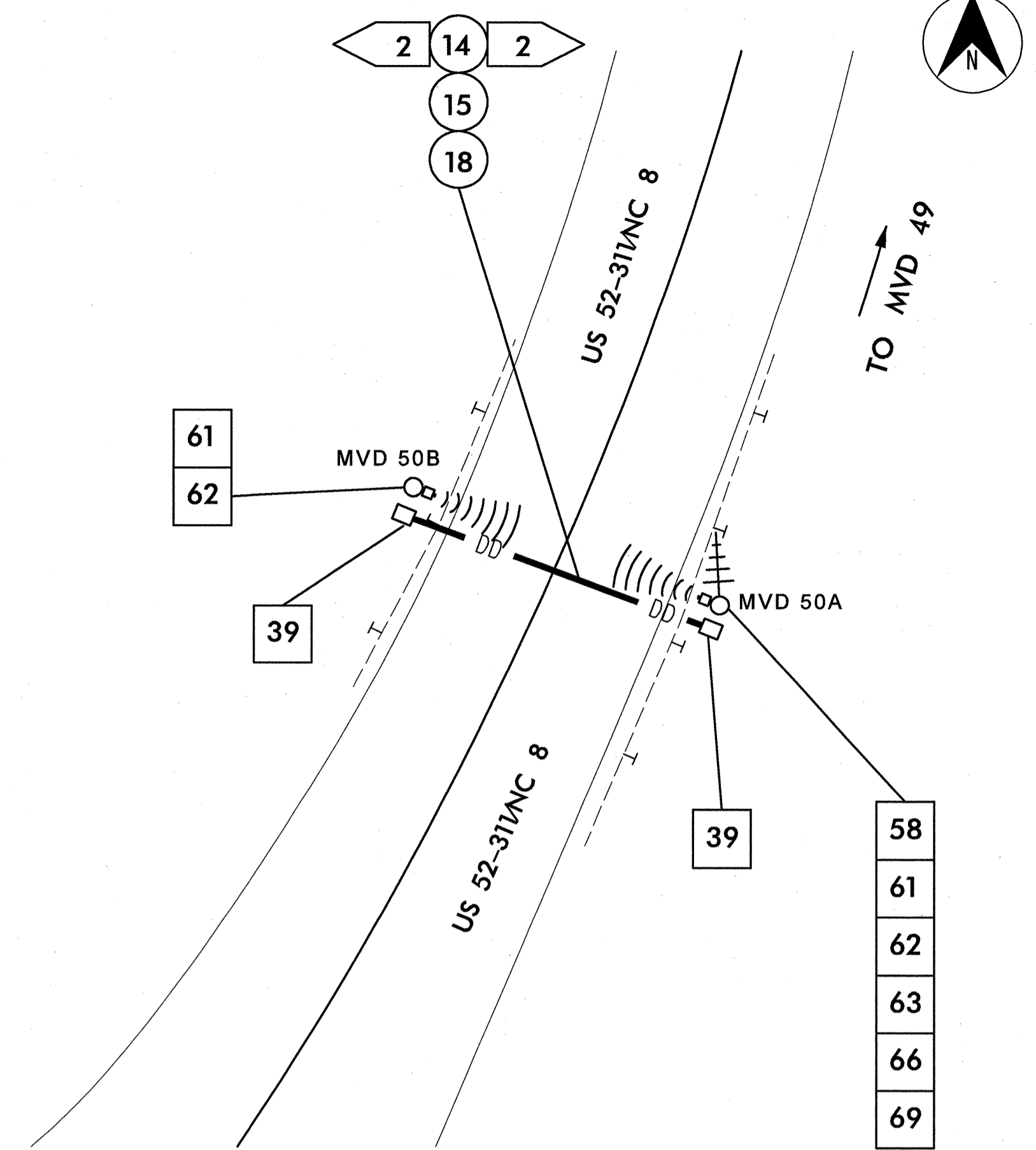

1/25/2011 11:47:17 AM jerry.cross k:\rd_tproj_its\0108658-us 52_its (u-2826b)\plan\sh 074.dgn

PLANS PREPARED IN THE OFFICE OF:

Kimley-Horn and Associates, Inc.
 P.O. Box 33068
 Raleigh N.C. 27636-3068
 (919) 877-2000
 N.C. License # F-0102

750 N. Greenfield Place, Garner, NC 27529

U-2826B	
CABLE ROUTING PLAN SHEET	
DIVISION 9 FORSYTH COUNTY WINSTON SALEM	
PLAN DATE: JANUARY 2011	REVIEWED BY:
PREPARED BY: J. Cross	REVIEWED BY: S. Privette
REVISIONS	INIT. DATE

SEAL

STEPHANIE B. PRIVETTE
 ENGINEER
 STATE OF NORTH CAROLINA
 LICENSE NO. 24432

1-25-11
 SIGNATURE DATE
 CADD Filename

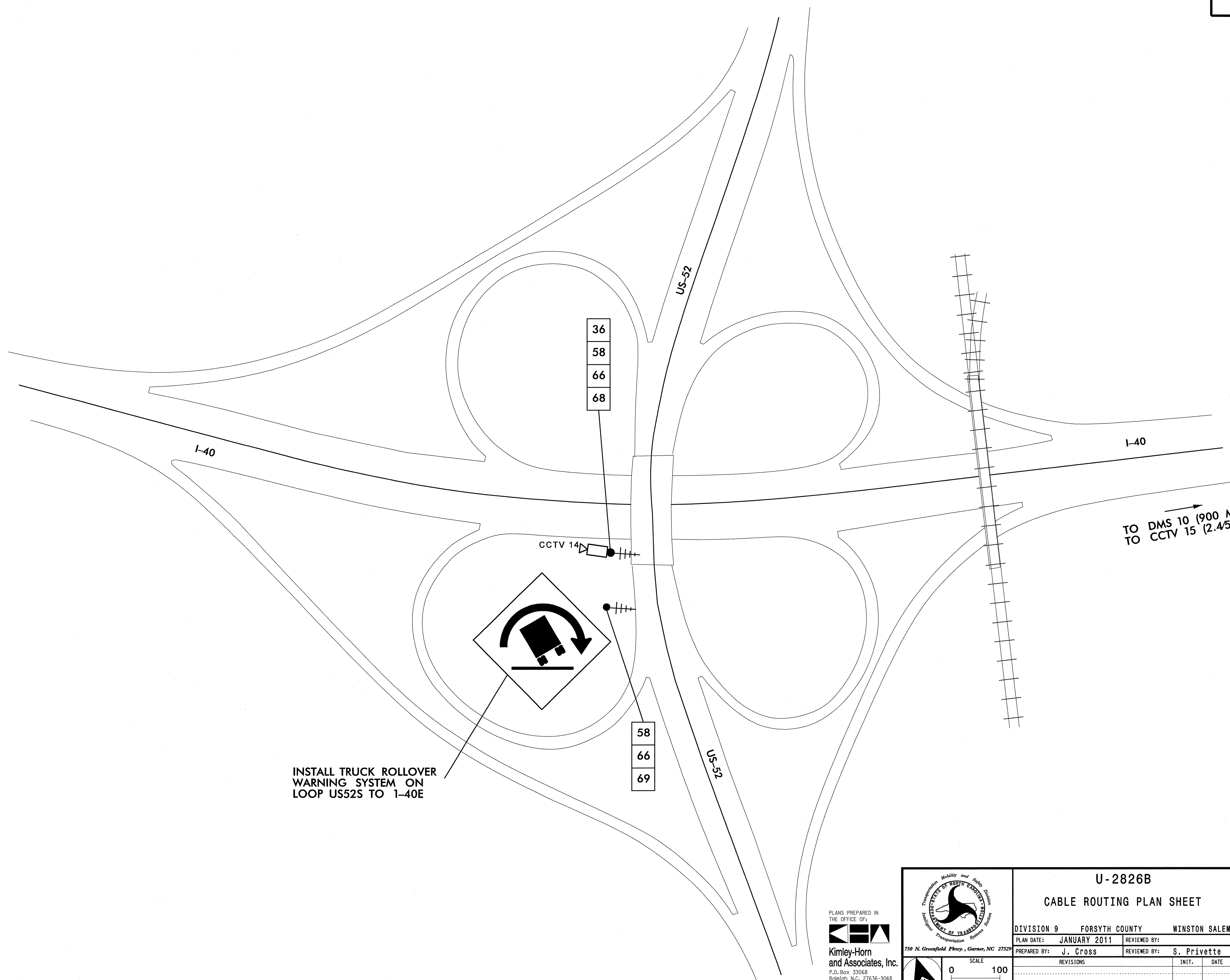

1/25/2011 11:07:18 AM jerry.cross k:\cal_tpro_its\01086158-us 52_its (u-2826b)\plan\sh 075.dgn

INSTALL TRUCK ROLLOVER WARNING SYSTEM ON LOOP US52S TO 1-40E

TO DMS 10 (900 MHz)
TO CCTV 15 (2.45.8 MHz)

PLANS PREPARED IN THE OFFICE OF:

Kimley-Horn and Associates, Inc.
 P.O. Box 33068
 Raleigh N.C. 27636-3068
 (919) 677-2000
 N.C. License # F-0102

750 N. Greenfield Pkwy., Garner, NC 27529

U-2826B	
CABLE ROUTING PLAN SHEET	
DIVISION 9 FORSYTH COUNTY WINSTON SALEM	
PLAN DATE: JANUARY 2011	REVIEWED BY:
PREPARED BY: J. Cross	REVIEWED BY: S. Privette
REVISIONS	INIT. DATE

SEAL

SIGNATURE DATE 1-25-11
 CADD Filename:

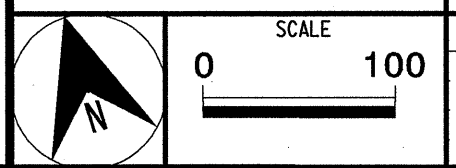

(A)

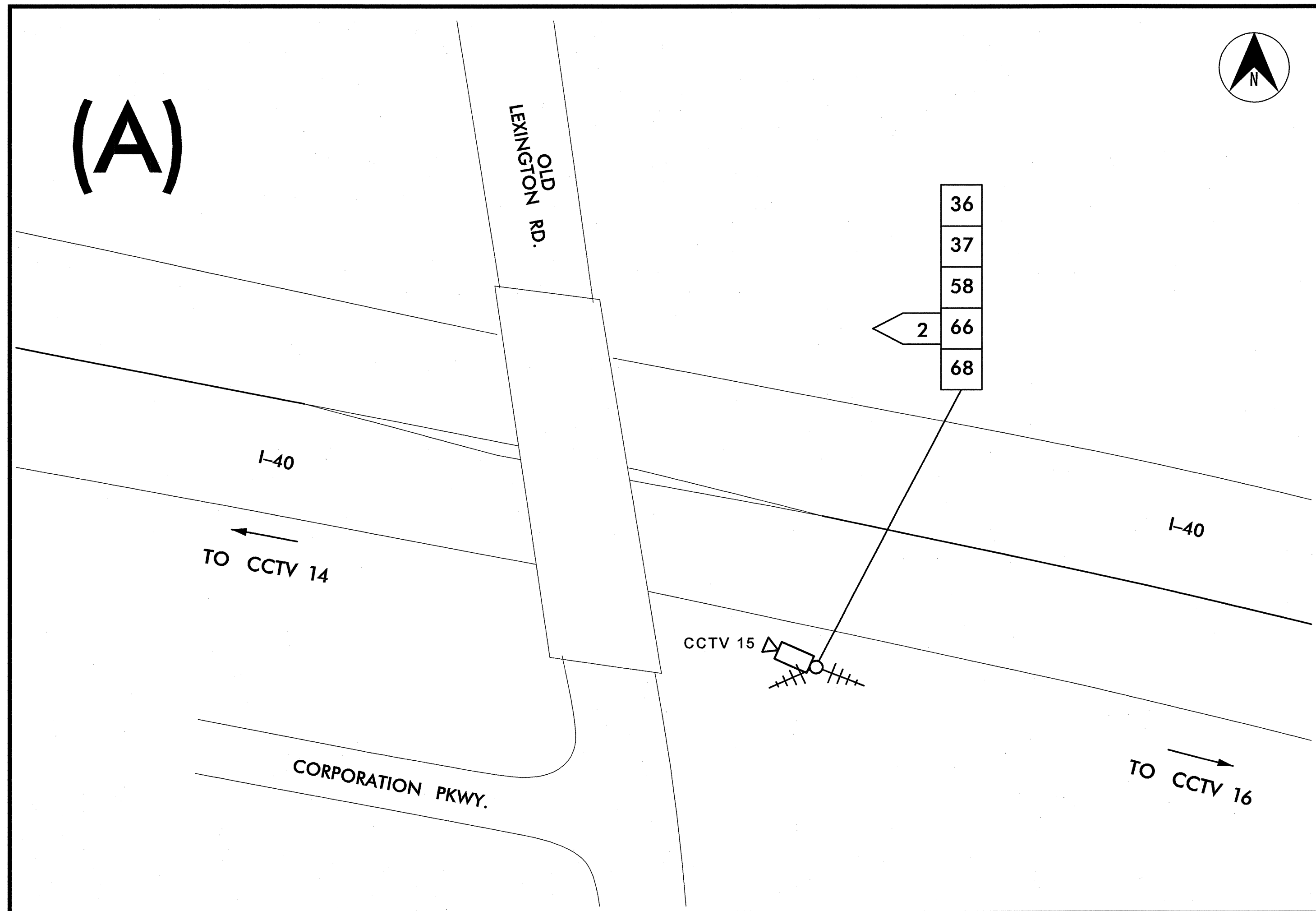

(B)

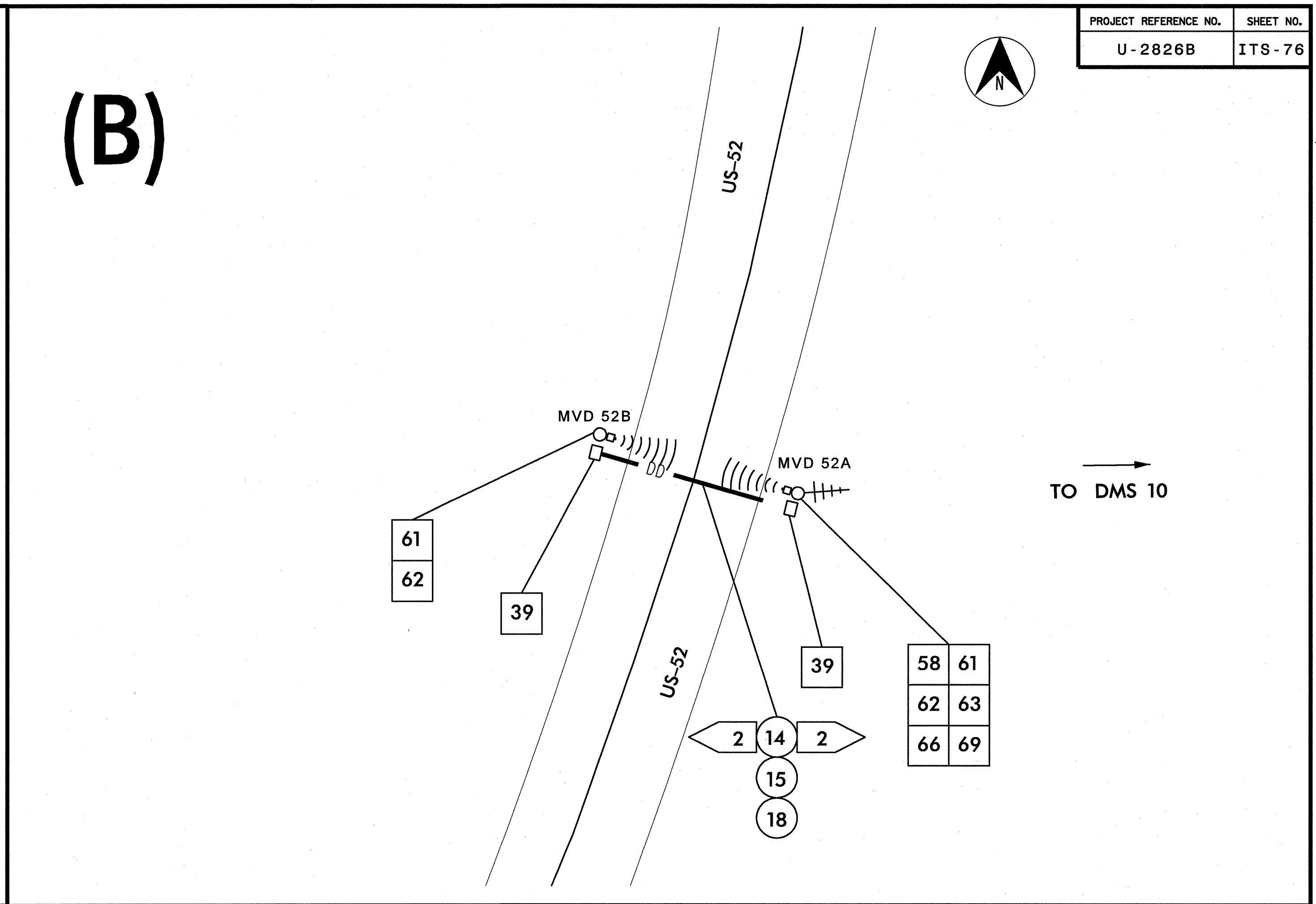

(C)

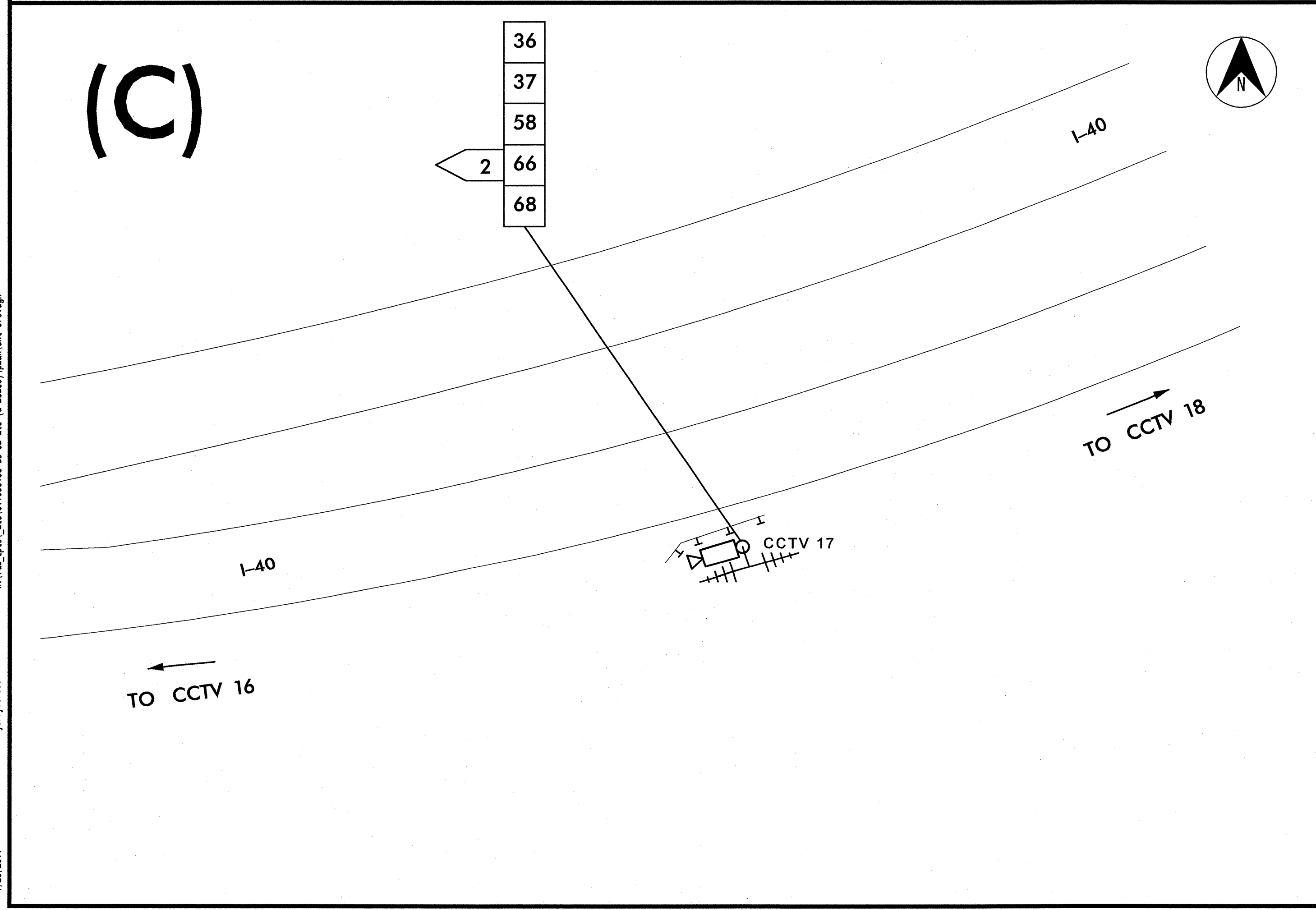

k:\real\proj_its\0108858-us_52_its (u-2826B)\plan\sh1 076.dgn
 11:47:19 AM jerry.cross
 1/25/2011

PLANS PREPARED IN THE OFFICE OF:

Kimley-Horn and Associates, Inc.
 P.O. Box 33068
 Raleigh, N.C. 27636-3068
 (919) 677-2000
 N.C. License # F-0102

750 N. Greenfield Pkwy., Garner, NC 27529
 SCALE: 0 50

U-2826B	
CABLE ROUTING PLAN SHEET	
DIVISION 9 FORSYTH COUNTY WINSTON SALEM	
PLAN DATE: JANUARY 2011	REVIEWED BY:
PREPARED BY: J. Cross	REVIEWED BY: S. Privette
REVISIONS	INIT. DATE

SEAL

SIGNATURE: *Stephanie B. Privette* DATE: 1/25/11
 CADD Filename:

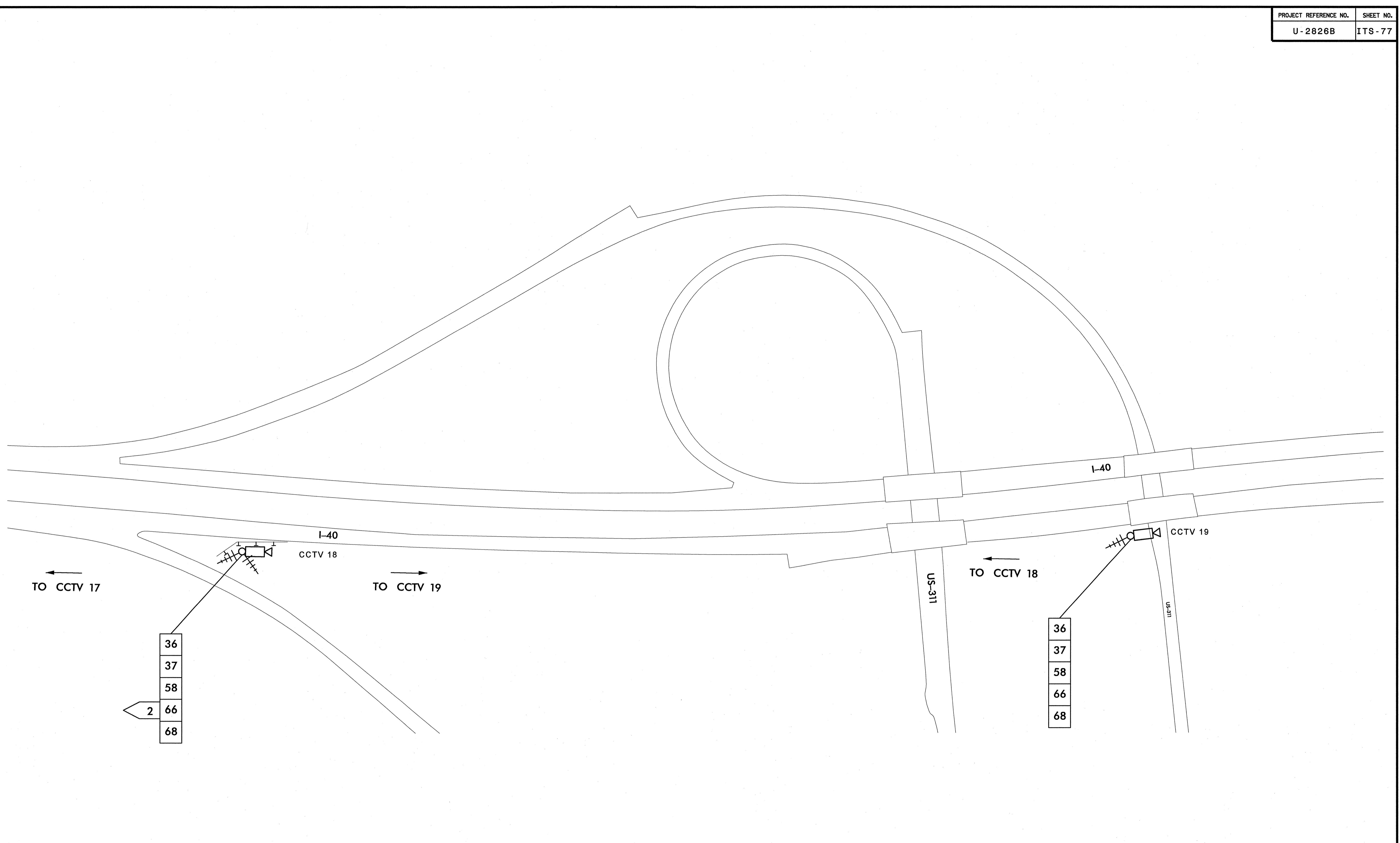

1/25/2011 11:47:20 AM jerry.cross
 k:\real_tproj_its\01056588-us 52_its (u-2826B)\plan\sh77.dgn

PLANS PREPARED IN THE OFFICE OF:

Kimley-Horn and Associates, Inc.
 P.O. Box 33068
 Raleigh N.C. 27636-3068
 (919) 677-2000
 N.C. License # F-0102

 759 N. Greenfield Place, Garner, NC 27529
 SCALE 0 100

U-2826B	
CABLE ROUTING PLAN SHEET	
DIVISION 9 FORSYTH COUNTY WINSTON SALEM	
PLAN DATE: JANUARY 2011	REVIEWED BY:
PREPARED BY: J. Cross	REVIEWED BY: S. Privette
REVISIONS	INIT. DATE

SEAL

 SIGNATURE: *Stephanie B. Privette* DATE: 1-25-11
 CADD Filename:

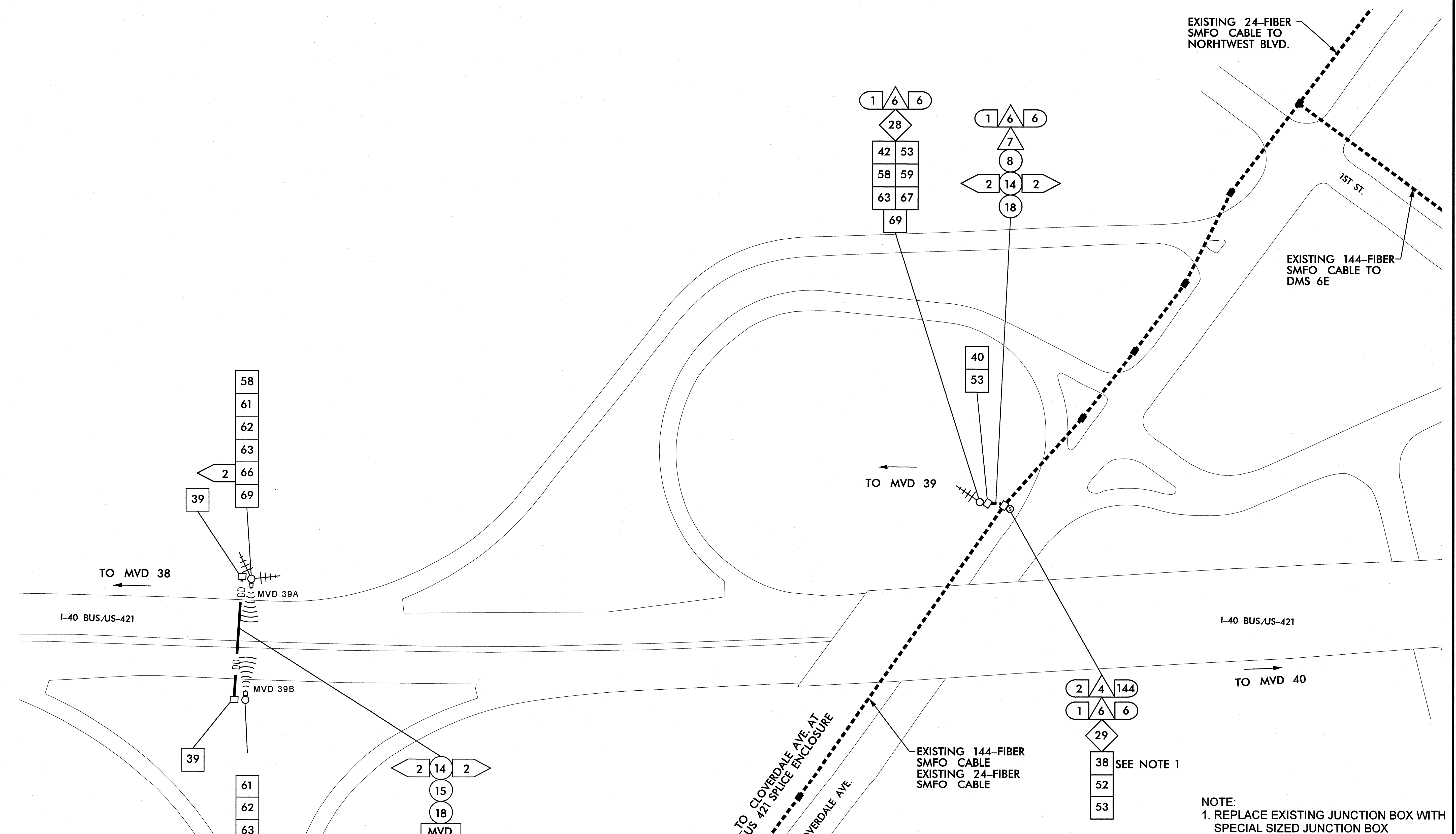

NOTE:
1. REPLACE EXISTING JUNCTION BOX WITH SPECIAL SIZED JUNCTION BOX

k:\net_tproj_its\01056158-us 52_its (u-2826B)\plan\sh8 078.dgn
 11:47:21 AM jerry.cross
 1/25/2011

PLANS PREPARED IN THE OFFICE OF:

Kimley-Horn and Associates, Inc.
 P.O. Box 33068
 Raleigh, N.C. 27636-3068
 (919) 677-2000
 N.C. License # F-0102

U-2826B	
CABLE ROUTING PLAN SHEET	
DIVISION 9 FORSYTH COUNTY WINSTON SALEM	
PLAN DATE: JANUARY 2011	REVIEWED BY:
PREPARED BY: J. Cross	REVIEWED BY: S. Privette
REVISIONS	INIT. DATE

SEAL

 SIGNATURE: *Stephanie B. Privette* 1-25-11
 DATE
 CADD Filenames

(A)

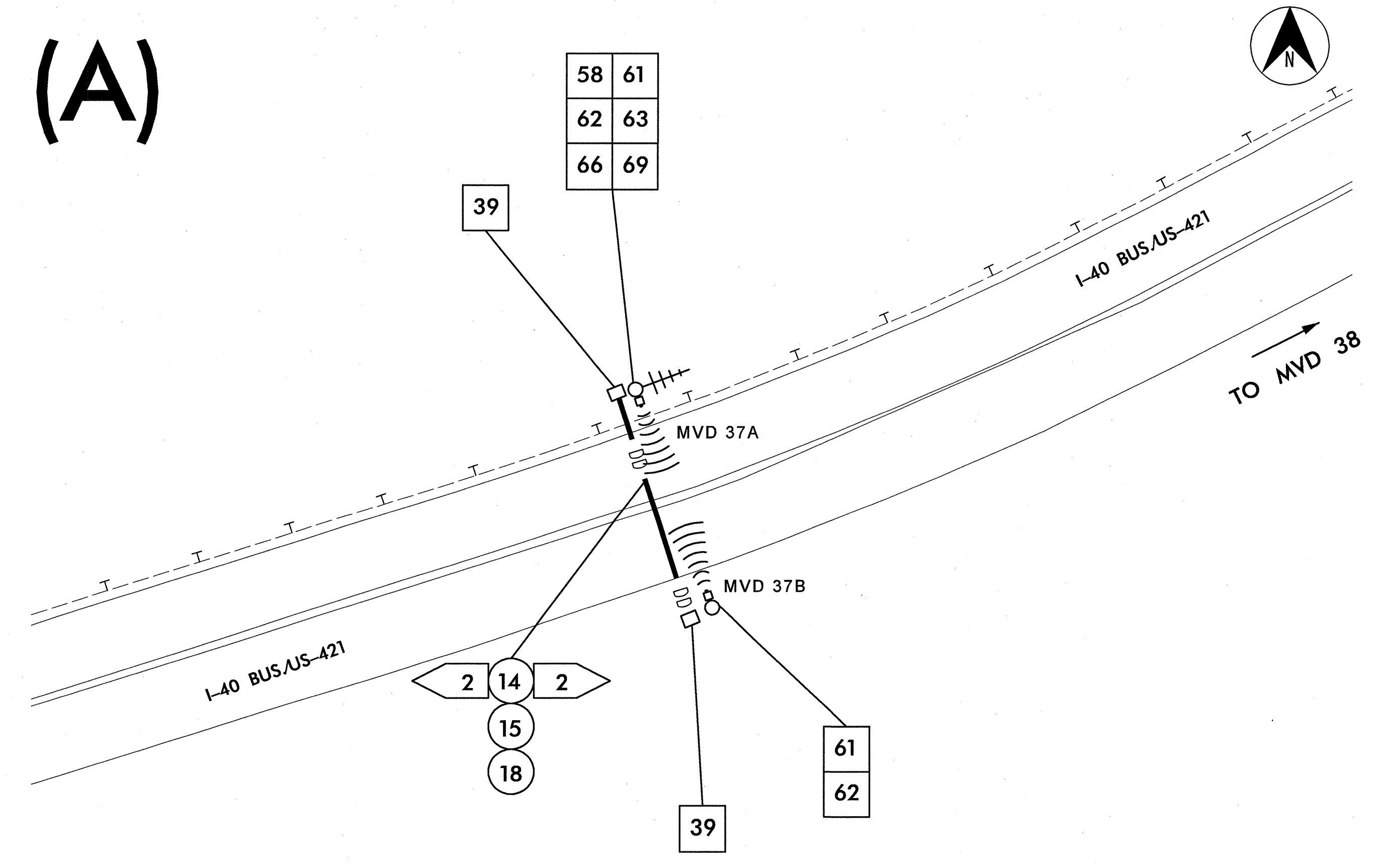

MVD 37: APPROXIMATELY 825' WEST OF WESTVIEW DRIVE

(B)

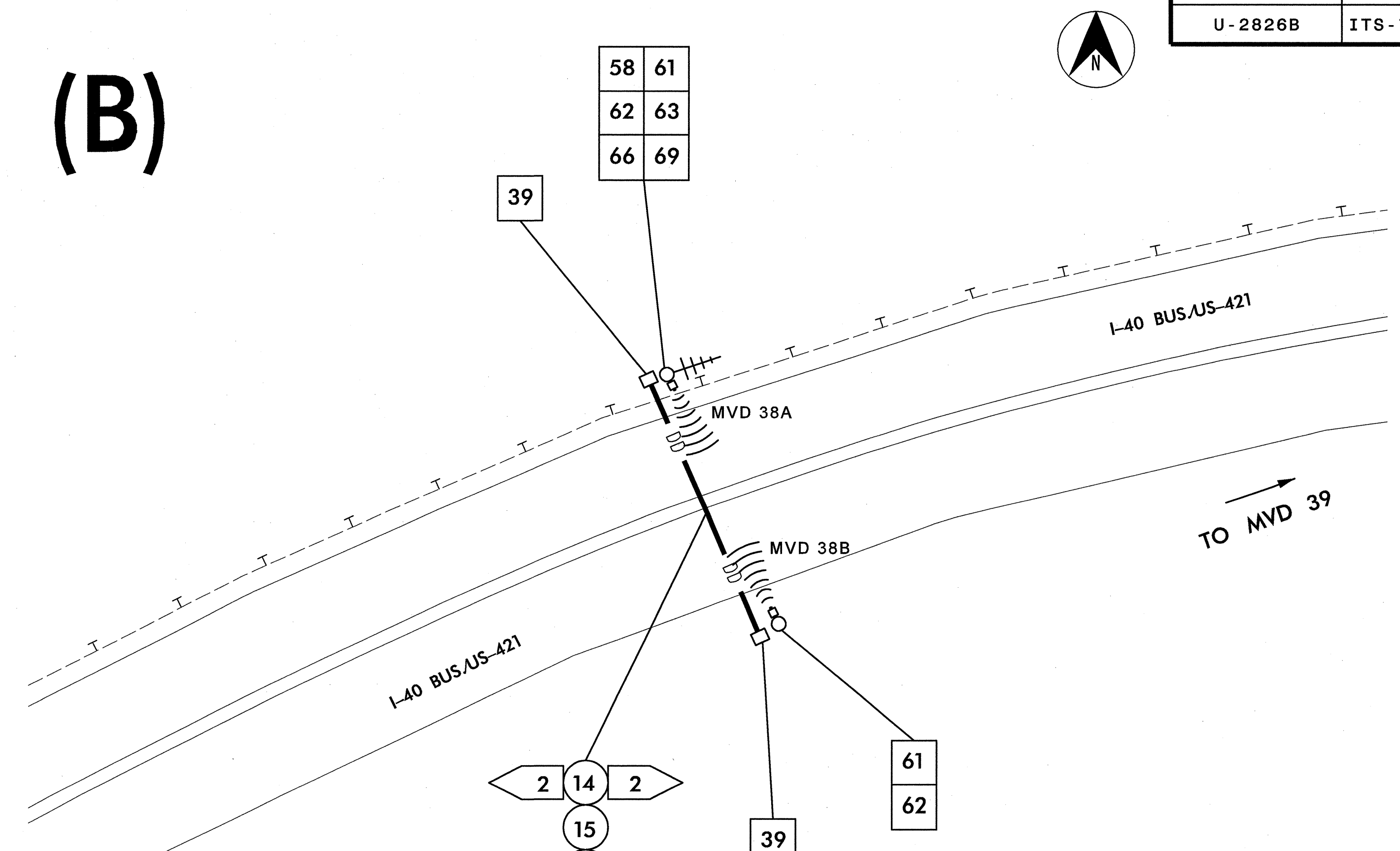

MVD 38: APPROXIMATELY 1100' WEST OF STRATFORD ROAD

(C)

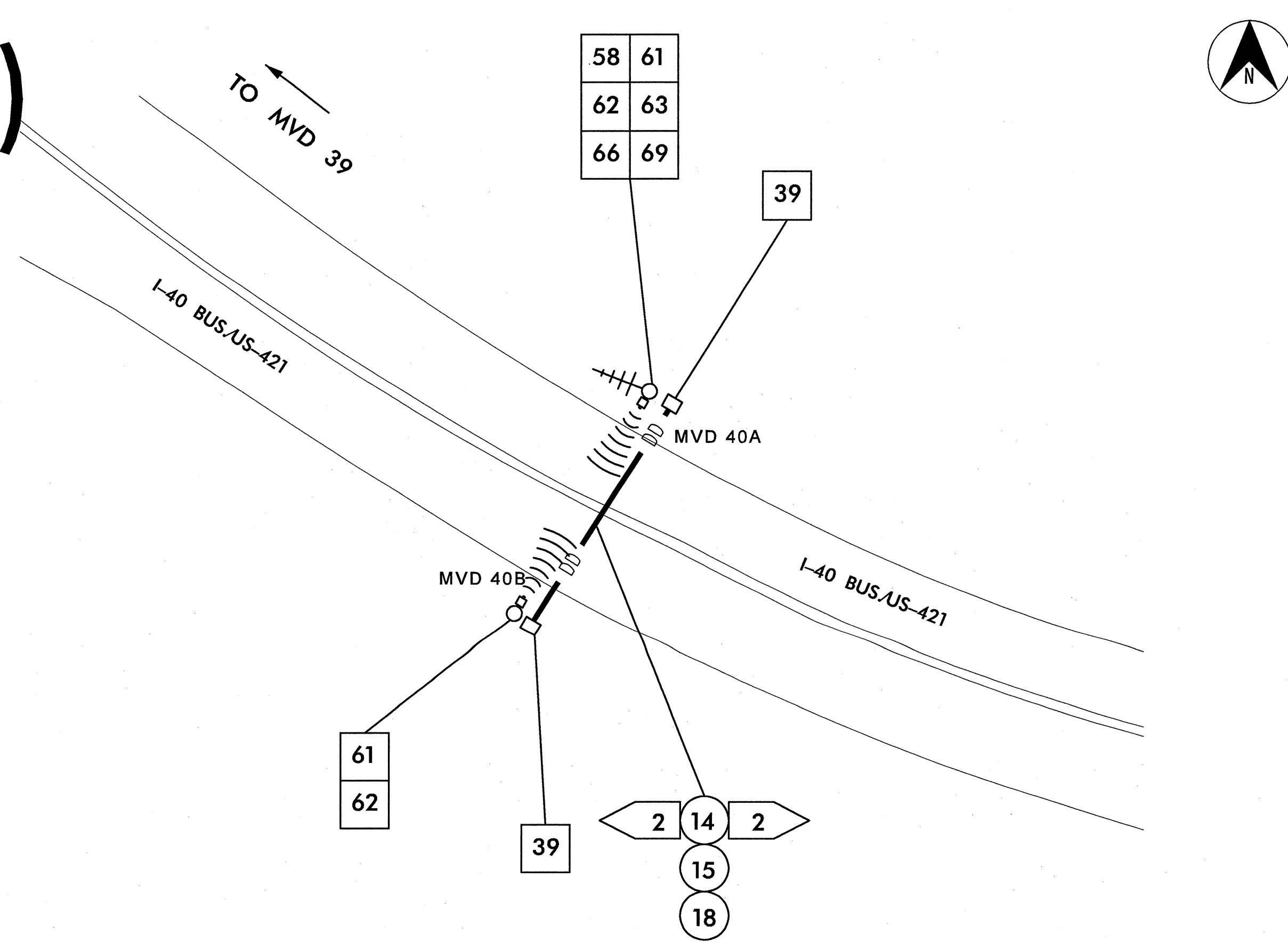

MVD 40: APPROXIMATELY 375' WEST OF CRAFTON STREET

(D)

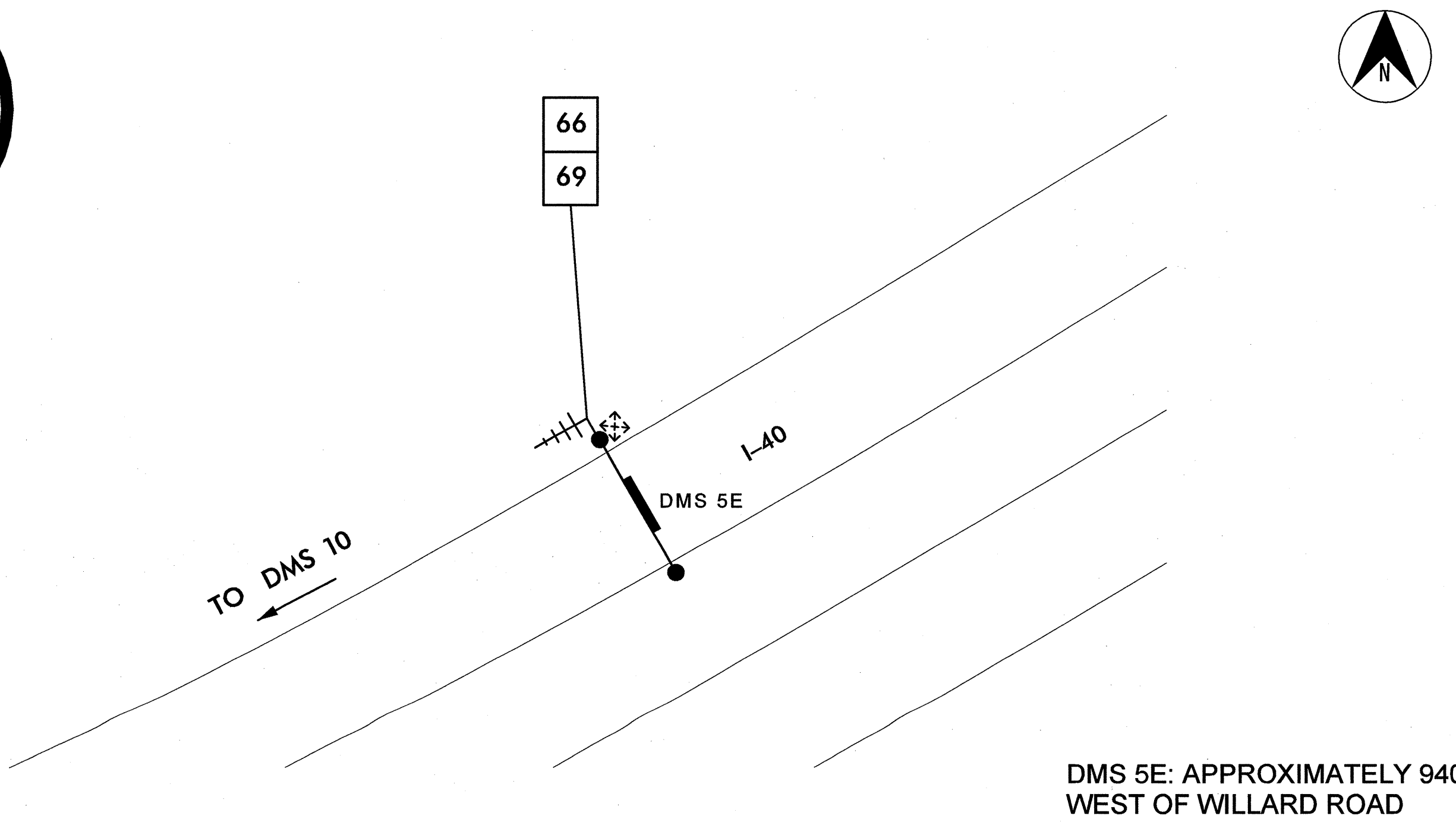

DMS 5E: APPROXIMATELY 940' WEST OF WILLARD ROAD

k:\rpl\proj_its\0108858-us_82_its (u-2826B)\plan\shc_079.dgn
 11-17-23 AM jerry_cross
 1/25/2011

PLANS PREPARED IN THE OFFICE OF:

Kimley-Horn and Associates, Inc.
 P.O. Box 33068
 Raleigh, N.C. 27636-3068
 (919) 677-2000
 N.C. License # F-0102

750 N. Greenfield Pkwy., Garner, NC 27529

U-2826B	
CABLE ROUTING PLAN SHEET	
DIVISION 9 FORSYTH COUNTY WINSTON SALEM	
PLAN DATE: JANUARY 2011	REVIEWED BY:
PREPARED BY: J. Cross	REVIEWED BY: S. Privette
REVISIONS	INIT. DATE

SEAL

SEAL 24432
 ENGINEER
 STEPHANIE B. PRIVETTE

Stephanie B. Privette 1/25/11
 SIGNATURE DATE
 CADD Filename:

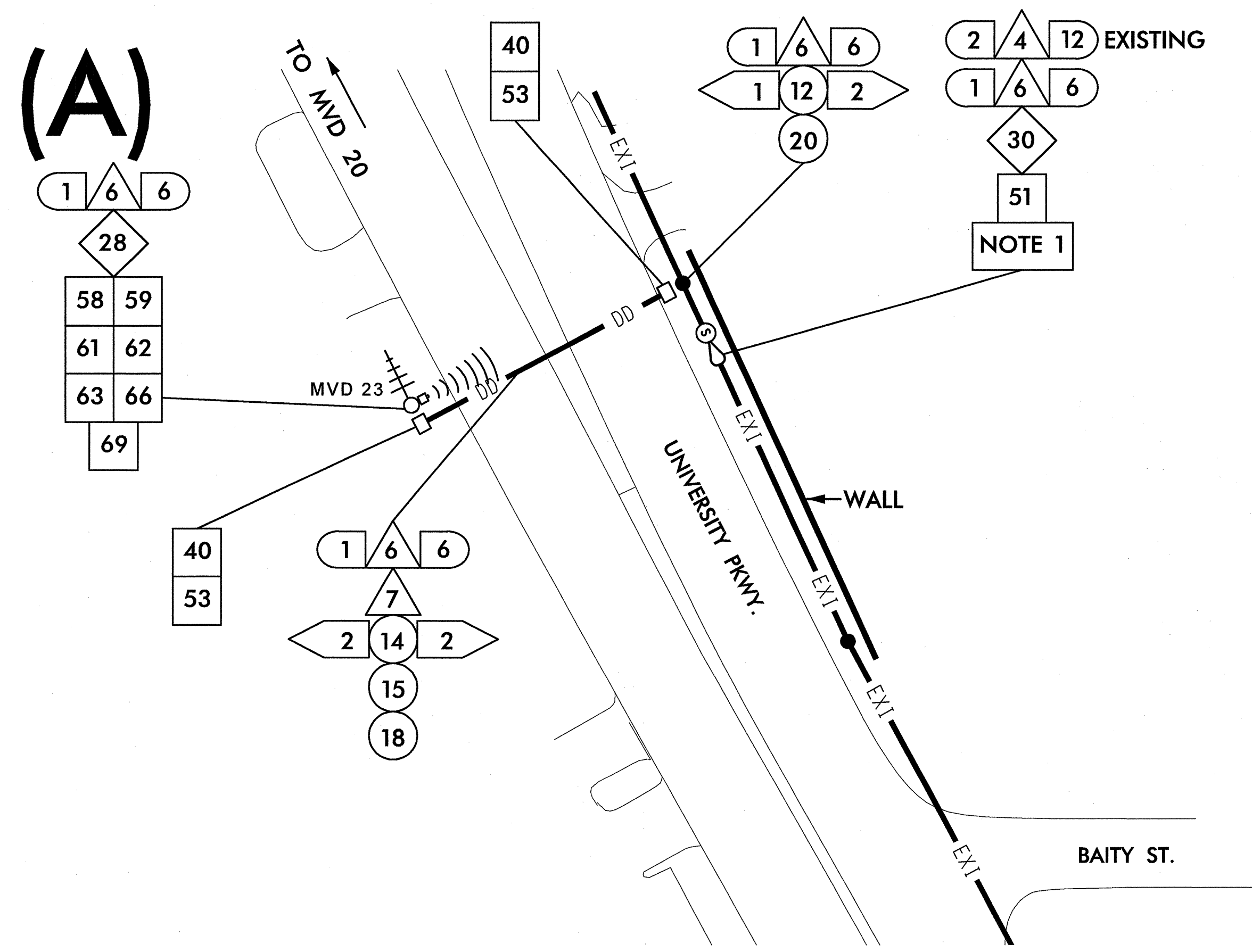

NOTE:
1. SPLICE SLACK INTO EXISTING FIBER OPTIC CABLE.

(B)

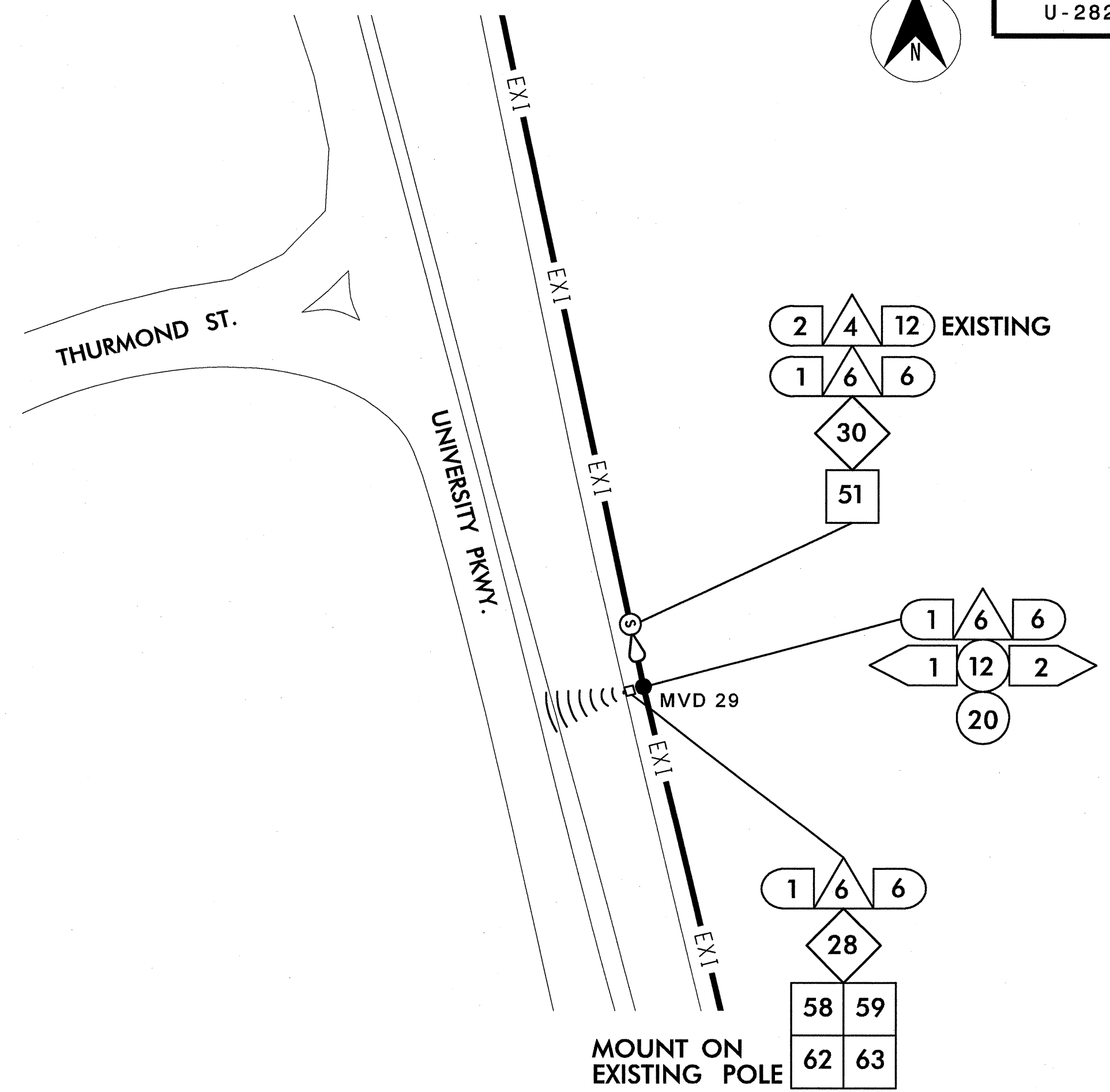

(C)

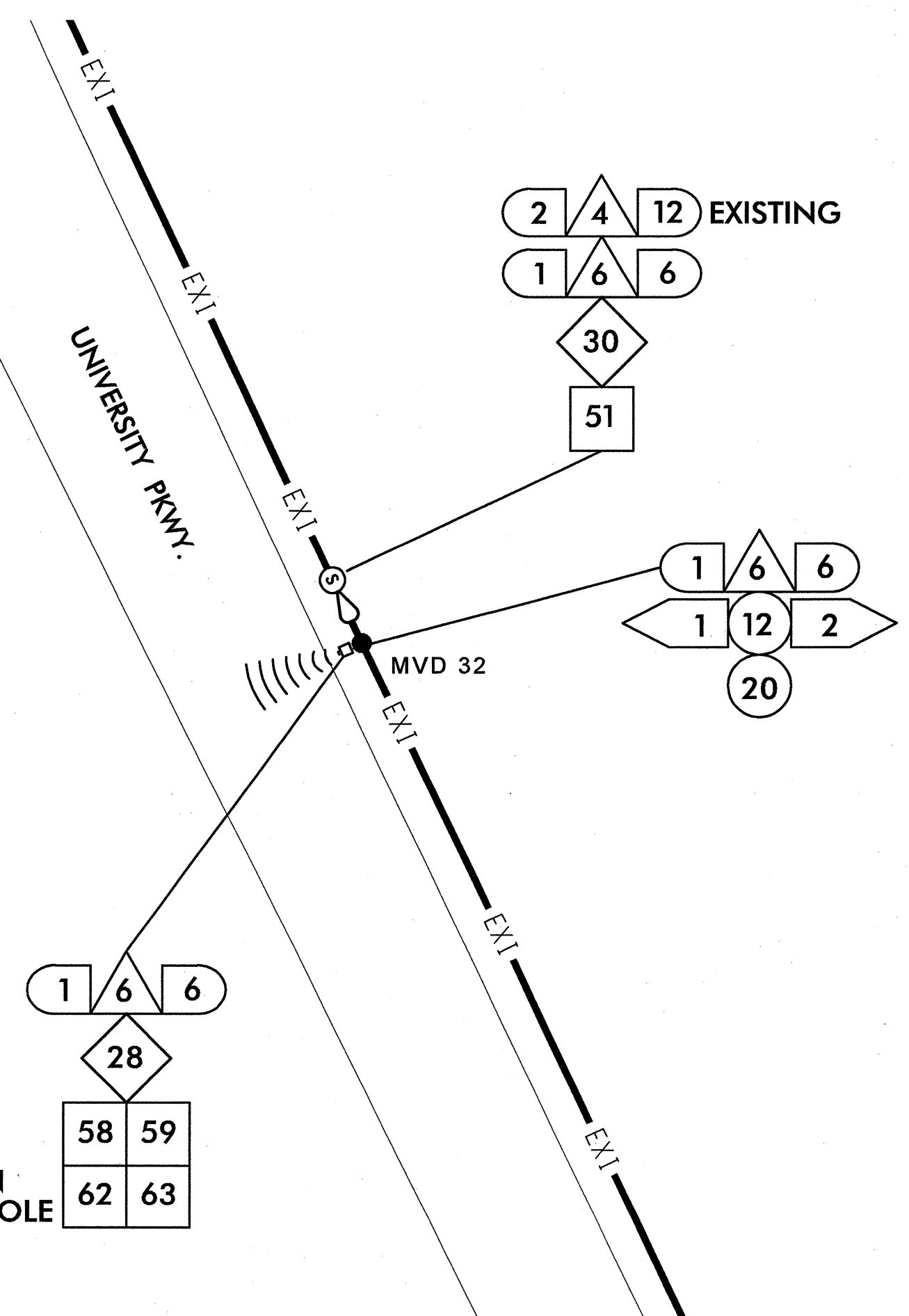

(D)

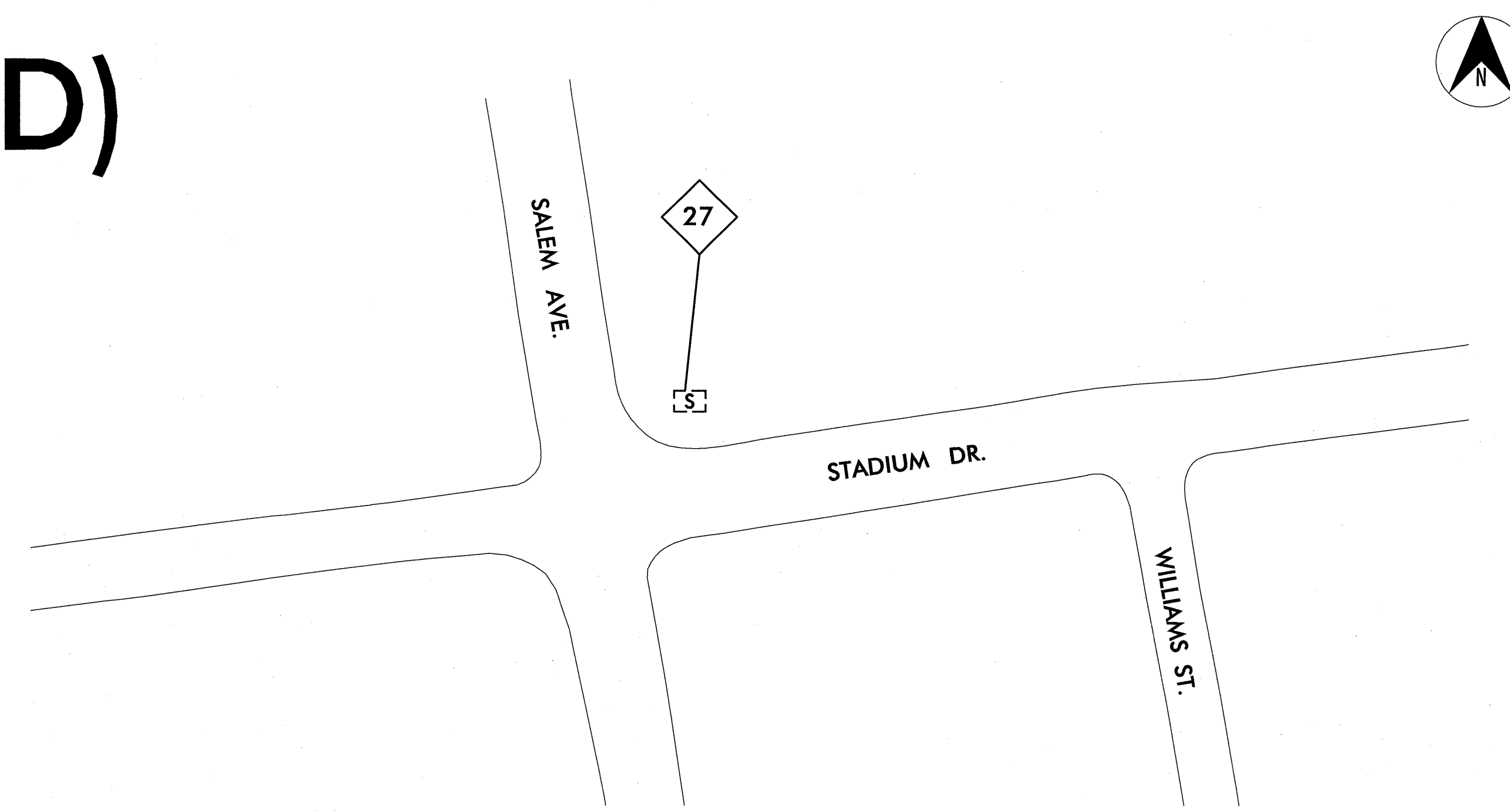

k:\nal_tran_fts\01056188-us 52_its (u-2826B)\plan\sh1 090.dgn
 1/25/2011 11:47:24 AM jerry.cross

PLANS PREPARED IN THE OFFICE OF:

Kimley-Horn and Associates, Inc.
 P.O. Box 33068
 Raleigh, N.C. 27636-3068
 (919) 677-2000
 N.C. License # F-0102

0 50
 SCALE

U-2826B	
CABLE ROUTING PLAN SHEET	
DIVISION 9 FORSYTH COUNTY WINSTON SALEM	
PLAN DATE: JANUARY 2011	REVIEWED BY:
PREPARED BY: J. Cross	REVIEWED BY: S. Privette
REVISIONS	INIT. DATE

SEAL

 SIGNATURE: *Stephanie B. Privette* DATE: 1.25.11
 CADD Filename:

(A)

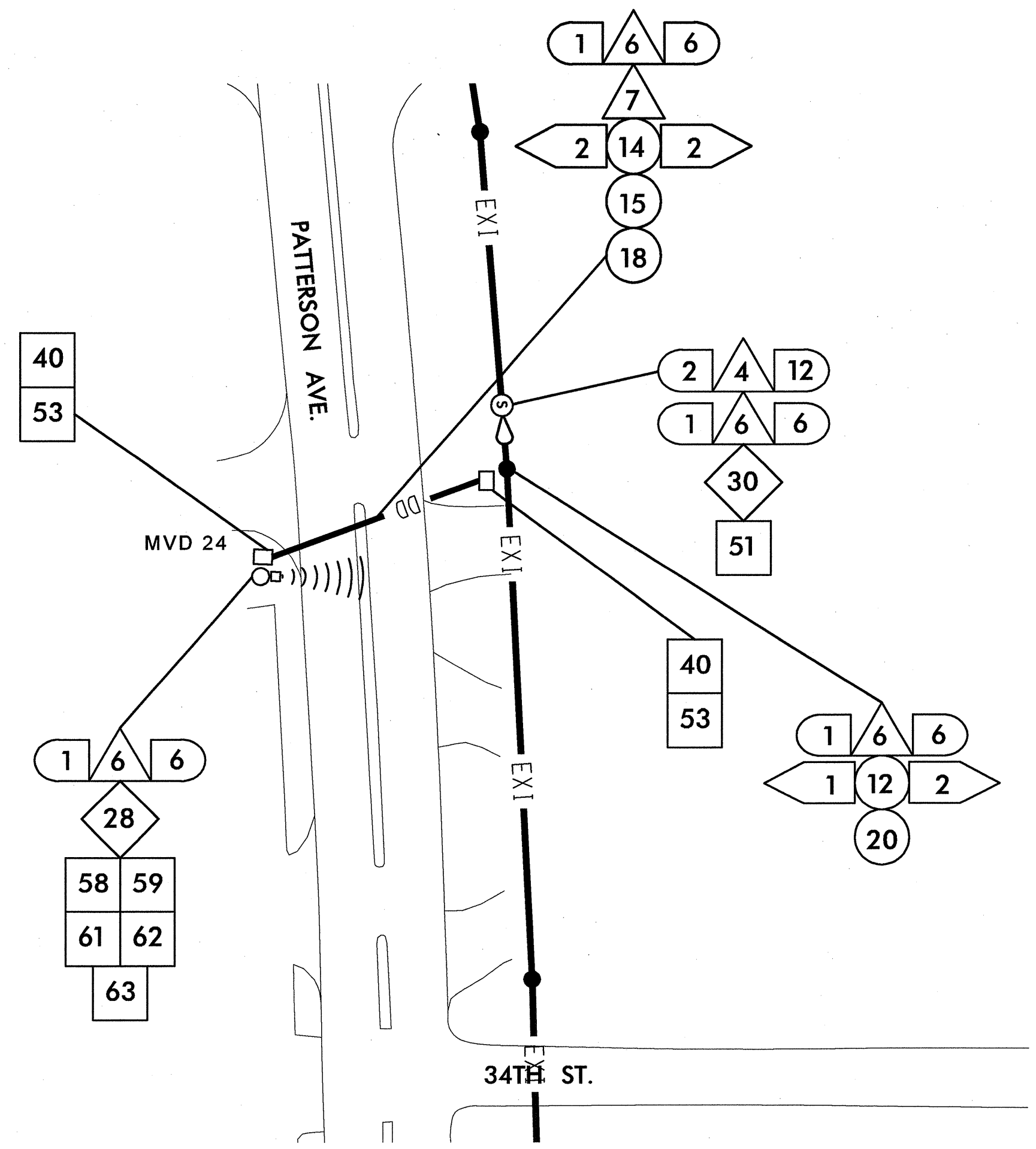

(B)

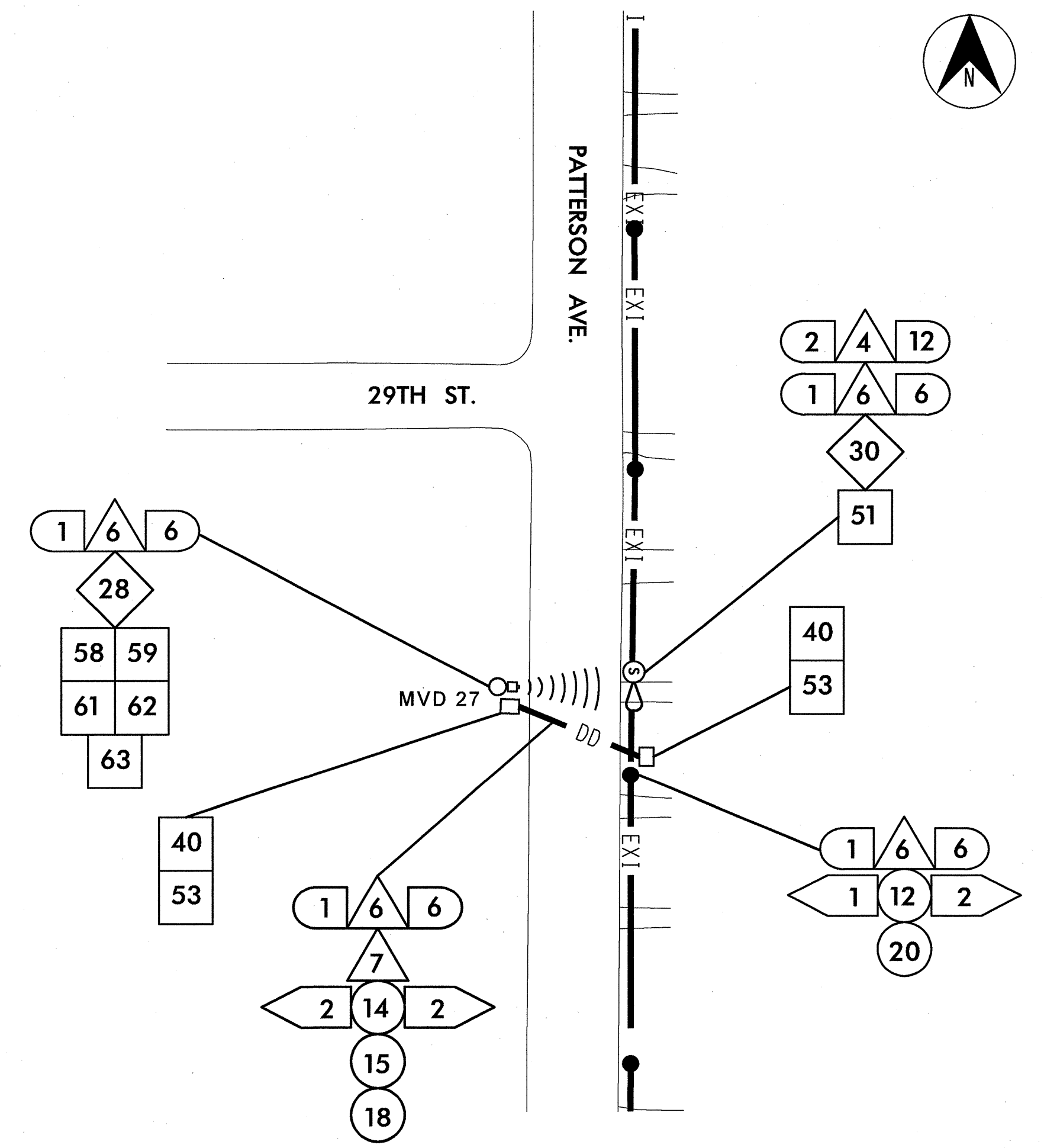

(C)

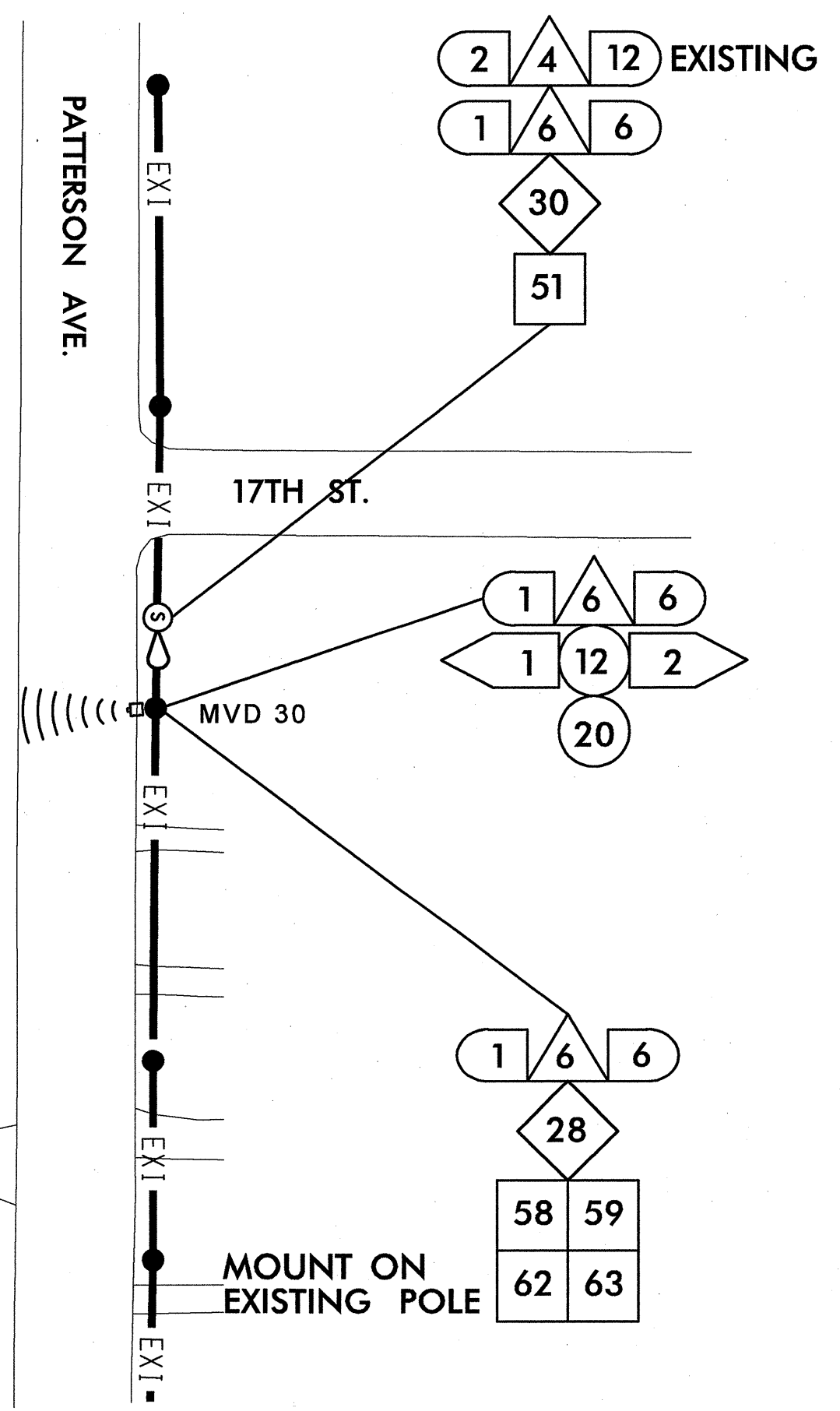

(D)

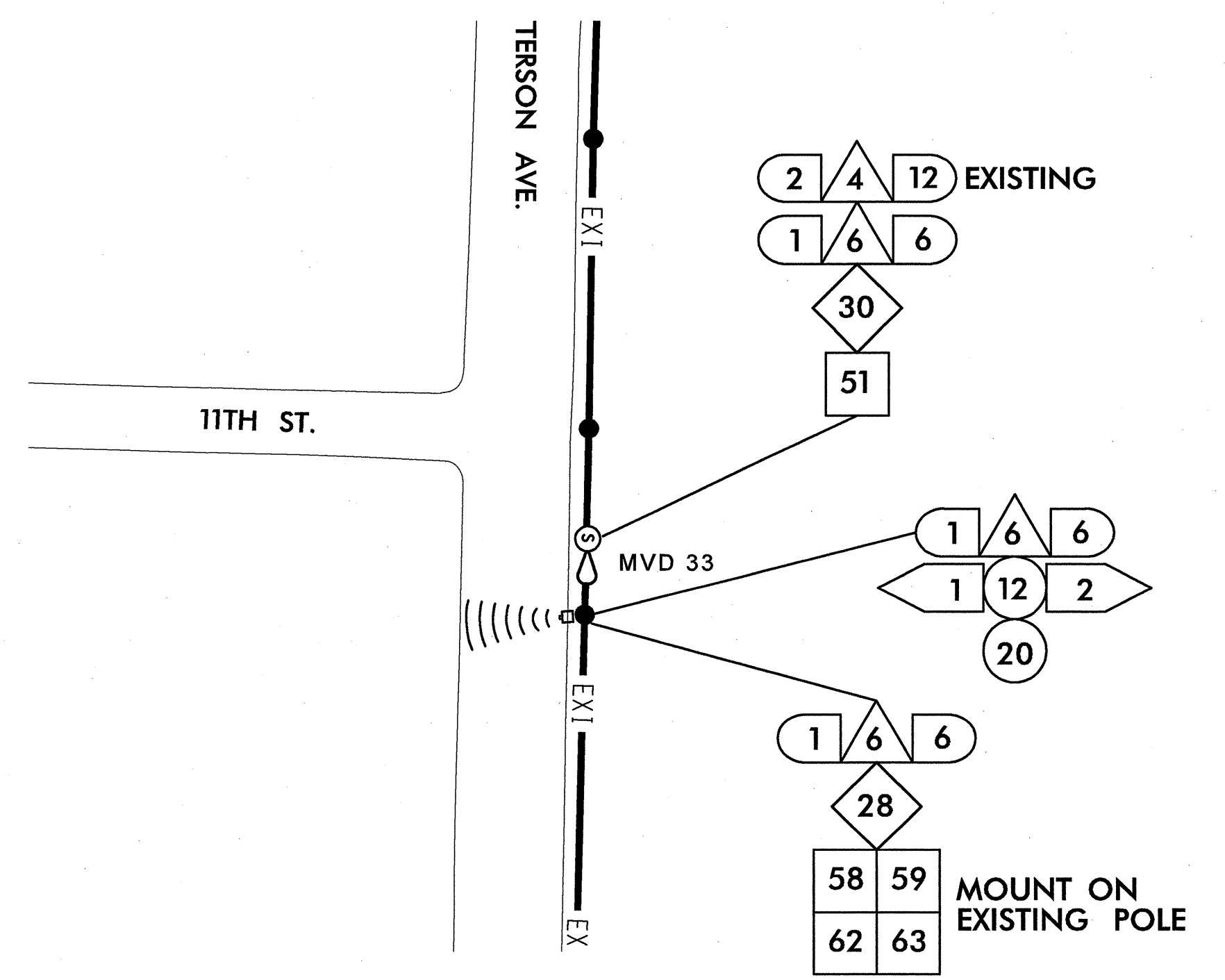

k:\rail_tproj_its\01056188-us 52_its (u-2826B)\plan\sh1 081.dgn
 11:47:25 AM Jerry Cross
 1/25/2011

PLANS PREPARED IN THE OFFICE OF:

Kimley-Horn and Associates, Inc.
 P.O. Box 33068
 Raleigh, N.C. 27636-3068
 (919) 677-2000
 N.C. License # F-0102

750 N. Greenfield Pkwy., Garner, NC 27529

SCALE
 0 50

U-2826B			
CABLE ROUTING PLAN SHEET			
DIVISION 9 FORSYTH COUNTY		WINSTON SALEM	
PLAN DATE: JANUARY 2011	REVIEWED BY:		
PREPARED BY: J. Cross	REVIEWED BY: S. Privette		
REVISIONS	INIT.	DATE	

SEAL

STEPHANIE B. PRIVETTE

DATE: 1-25-11

CADD Filename: _____

(A)

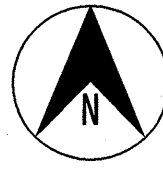
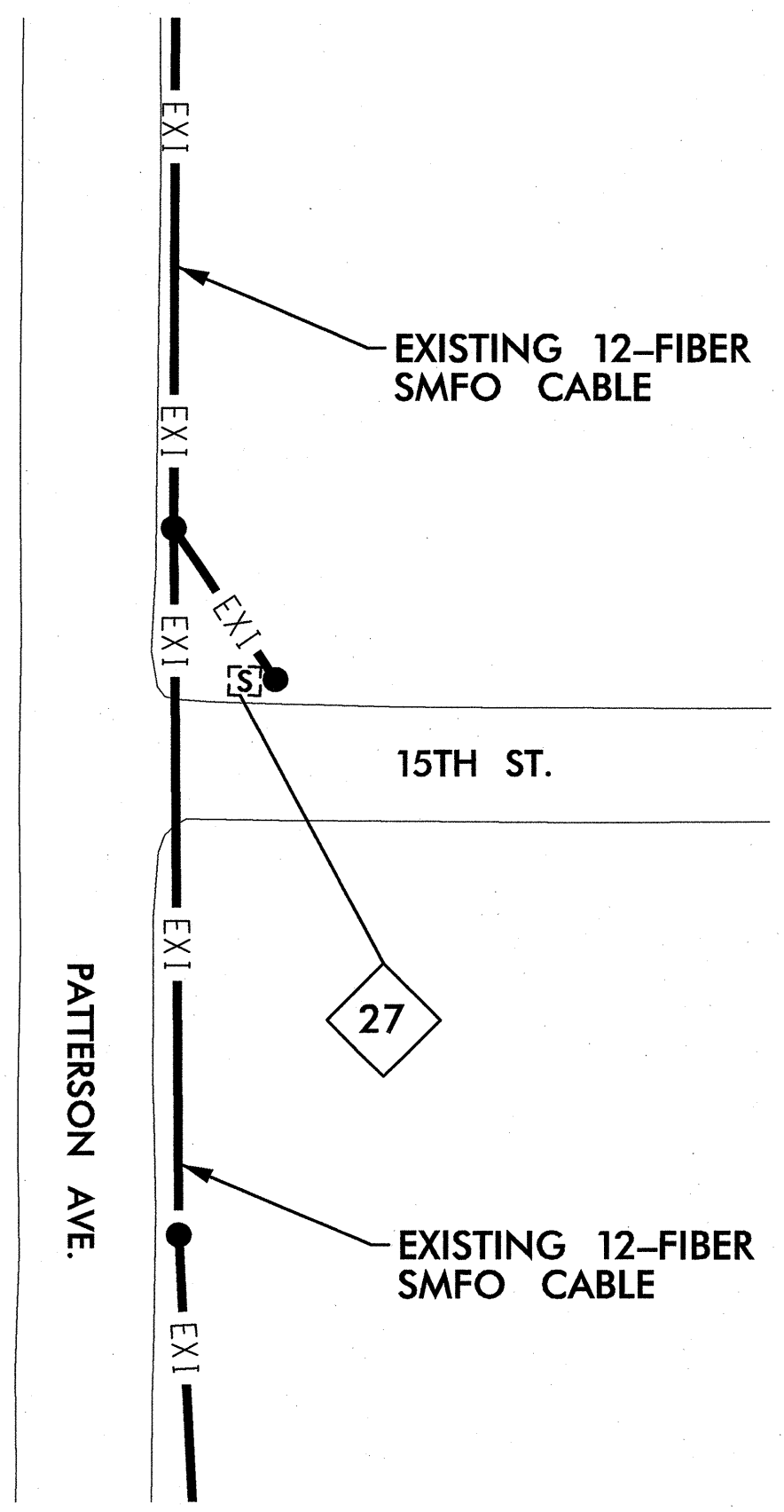

(B)

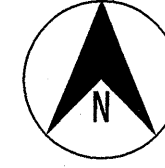
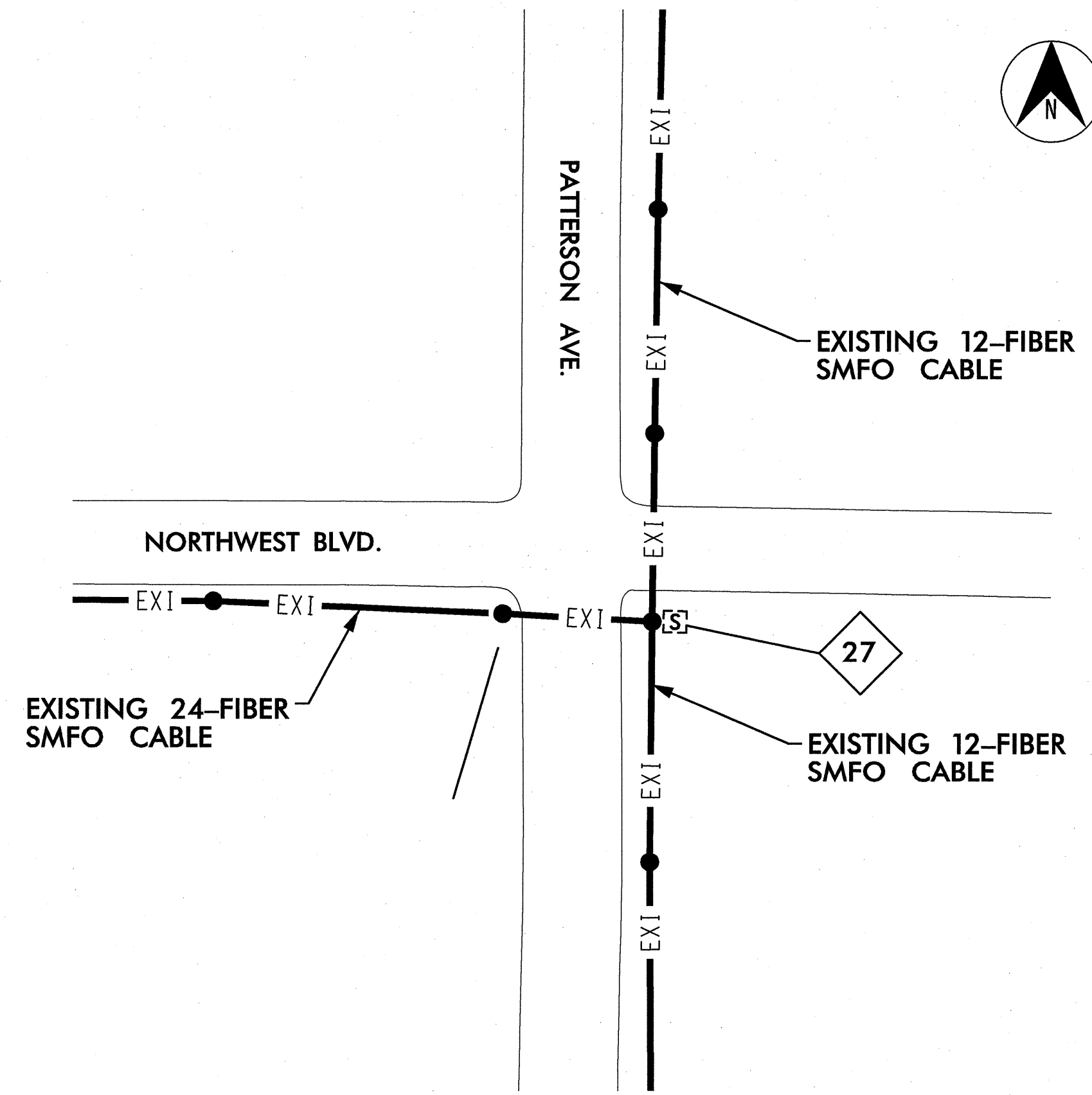

(C)

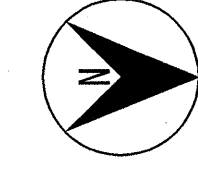
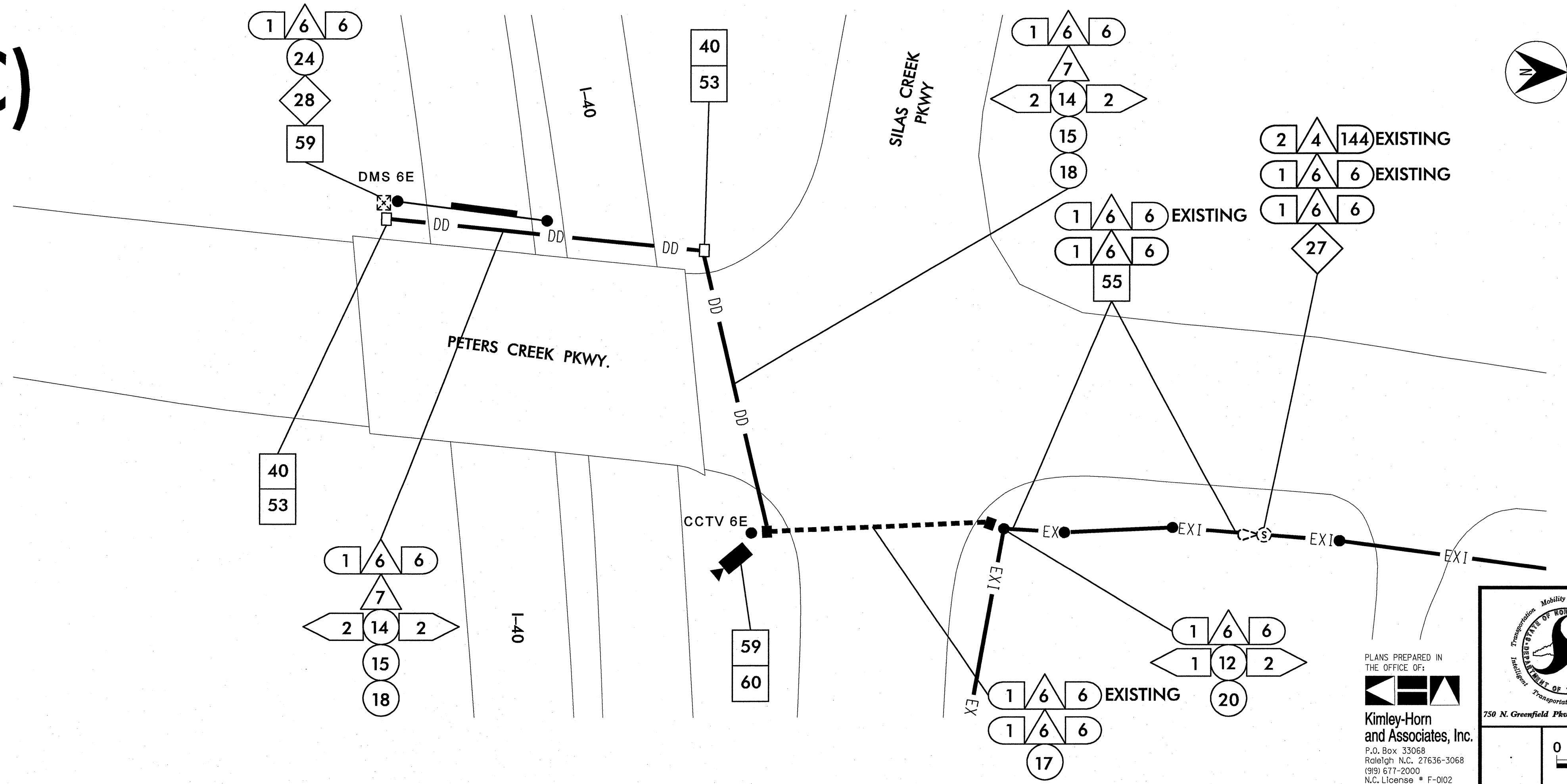

PLANS PREPARED IN THE OFFICE OF:

Kimley-Horn and Associates, Inc.
 P.O. Box 33068
 Raleigh, N.C. 27636-3068
 (919) 677-2000
 N.C. License # F-002

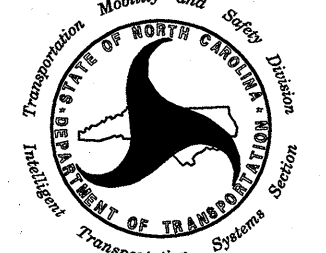
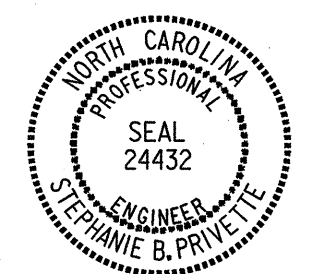
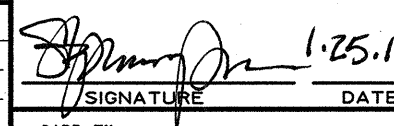
 PROFESSIONAL ENGINEER STATE OF NORTH CAROLINA TRANSPORTATION 750 N. Greenfield Pkwy., Garner, NC 27529	U-2826B		SEAL  NORTH CAROLINA PROFESSIONAL ENGINEER SEAL 24432 STEPHANIE B. PRIVETTE
	CABLE ROUTING PLAN SHEET		
	DIVISION 9 FORSYTH COUNTY WINSTON SALEM		
	PLAN DATE: JANUARY 2011	REVIEWED BY:	
PREPARED BY: J. Cross	REVIEWED BY: S. Privette		
SCALE	REVISIONS	INIT.	DATE
0 50			
		 1-25-11 SIGNATURE DATE CADD Filename	

k:\ra1_proj_its\011036158-us_82_its (u-2826B)\plan\shet 082.dgn
 10:12:17 AM jbrty_cross
 1/26/2011