



|                 |           |
|-----------------|-----------|
| TIP NO.         | SHEET NO. |
| U-3306          | PMP-2     |
| APPROVED: _____ |           |
| DATE: _____     |           |
| SEAL            |           |
|                 |           |

**PAVEMENT MARKINGS**

**THERMOPLASTIC(4", 90 MILS)**

TB YELLOW EDGELINE

**THERMOPLASTIC(4", 120 MILS)**

T8 2 FT. - 8 FT./SP WHITE MINISKIP  
 TC 10 FT. WHITE SKIP  
 TD 2 FT. - 13 FT./SP WHITE MINISKIP  
 TE WHITE SOLID LANE LINE  
 TF 10 FT. YELLOW SKIP  
 TH YELLOW SINGLE CENTER  
 TI YELLOW DOUBLE CENTER

**THERMOPLASTIC(8", 90 MILS)**

TP WHITE GORELINE  
 TT YELLOW DIAGONAL

**THERMOPLASTIC(8", 120 MILS)**

TV WHITE CROSSWALK LINE

**THERMOPLASTIC(12", 120 MILS)**

T10 3 FT. - 3 FT./SP WHITE MINISKIP

**THERMOPLASTIC(24", 120 MILS)**

T2 WHITE STOPBAR  
 T3 WHITE CROSSWALK LINE

**THERMOPLASTIC PAVEMENT MARKING CHARACTER (120 MILS)**

UI ALPHANUMERIC CHAR.

**THERMOPLASTIC PAVEMENT MARKING SYMBOLS (90 MILS)**

UA LEFT TURN ARROW  
 UB RIGHT TURN ARROW  
 UC STRAIGHT ARROW  
 UD COMBO.STRAIGHT/LEFT  
 UE COMBO.STRAIGHT/RIGHT  
 UG LEFT/RIGHT/STRAIGHT  
 UJ BICYCLE SYMBOL (SKID RESISTANT, HEATED-IN-PLACE)  
 UK BICYCLE STRAIGHT ARROW (SKID RESISTANT, HEATED-IN-PLACE)  
 UN 24" YIELD LINE TRIANGLE

**PERMANENT RAISED PAVEMENT MARKERS**

MA - YELLOW & YELLOW  
 MB - CRYSTAL & RED

**PAVEMENT MARKING SCHEDULE**

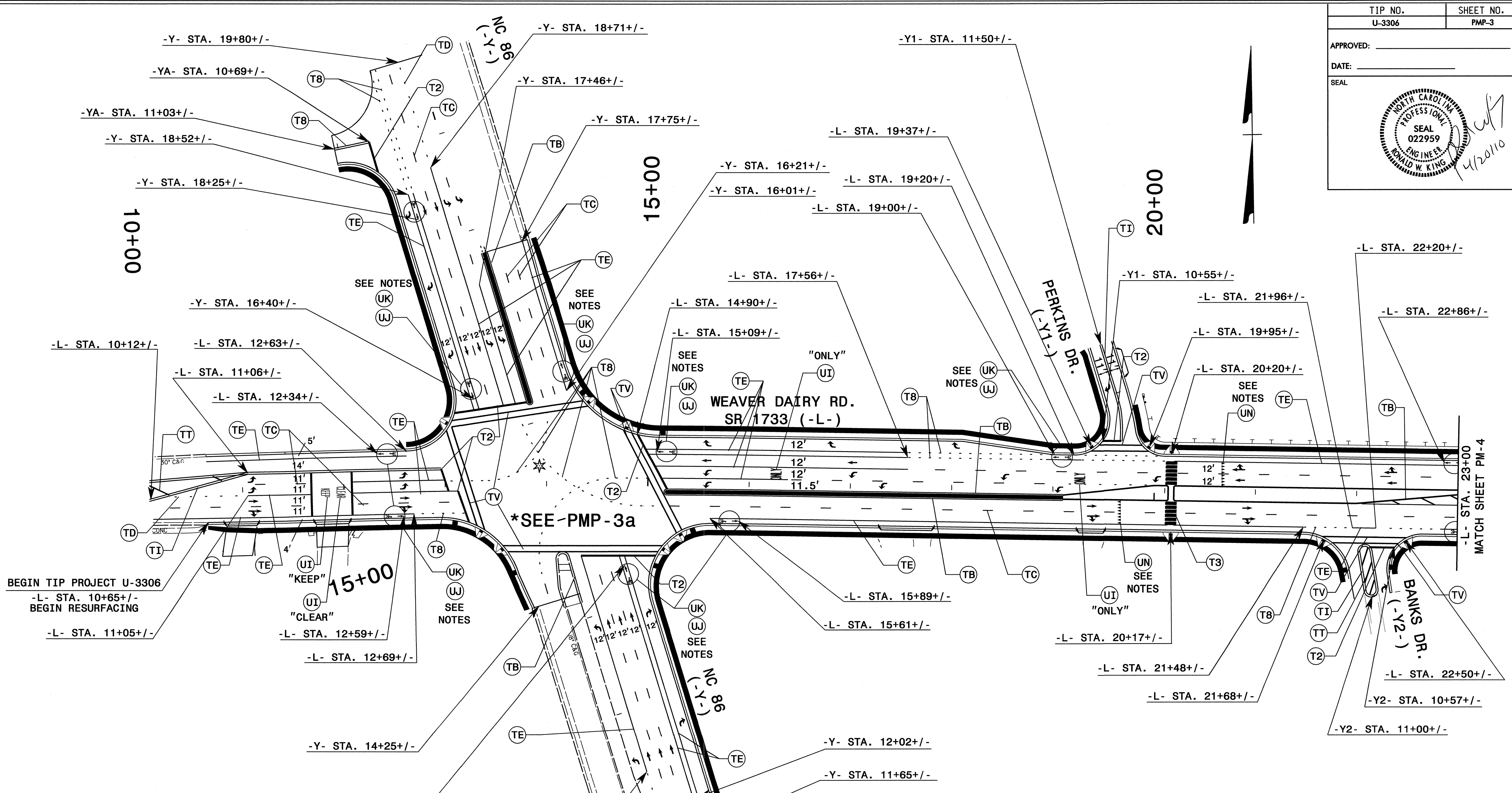

**NOTES**

|                         |   |                          |                                    |
|-------------------------|---|--------------------------|------------------------------------|
|                         |   |                          |                                    |
| LEFT TURN ARROW<br>(UA) | STRAIGHT ARROW<br>(UC)  | RIGHT TURN ARROW<br>(UB) | STRAIGHT/RIGHT COMBO ARROW<br>(UE) |
|                         | UNLESS OTHERWISE SHOWN, PAVEMENT MARKINGS, SYMBOLS, CHARACTERS, AND MARKERS SHALL BE PLACED ACCORDING TO ROADWAY STANDARD DRAWING NO. 1205.01, 1205.02, 1205.04, 1205.05, 1205.06, 1205.07, 1205.08, 1205.09, 1250.01, 1251.01. |                          |                                    |

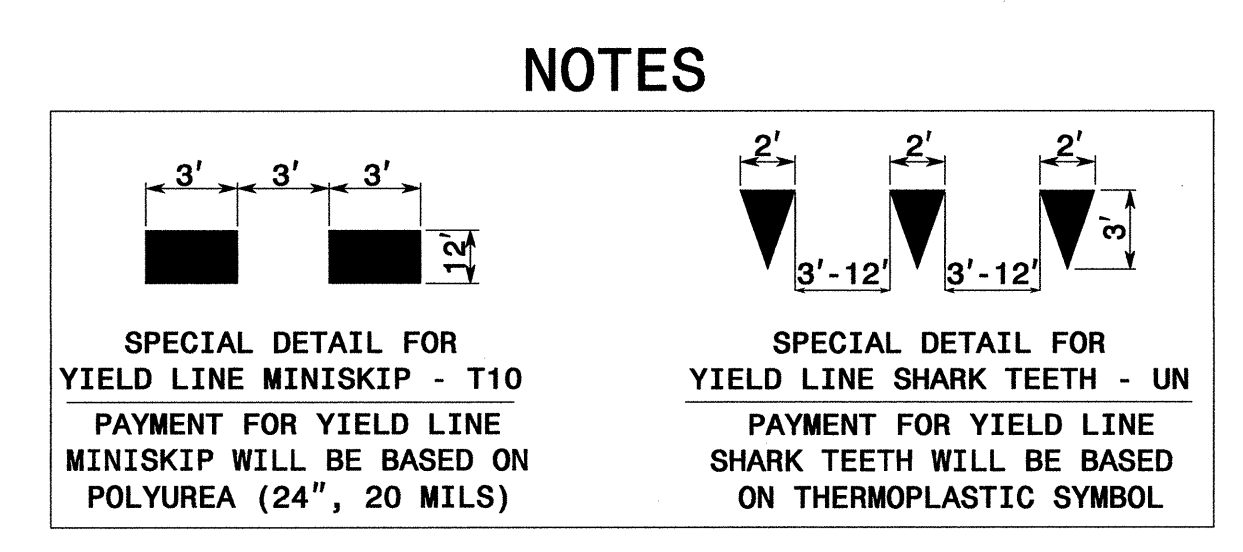
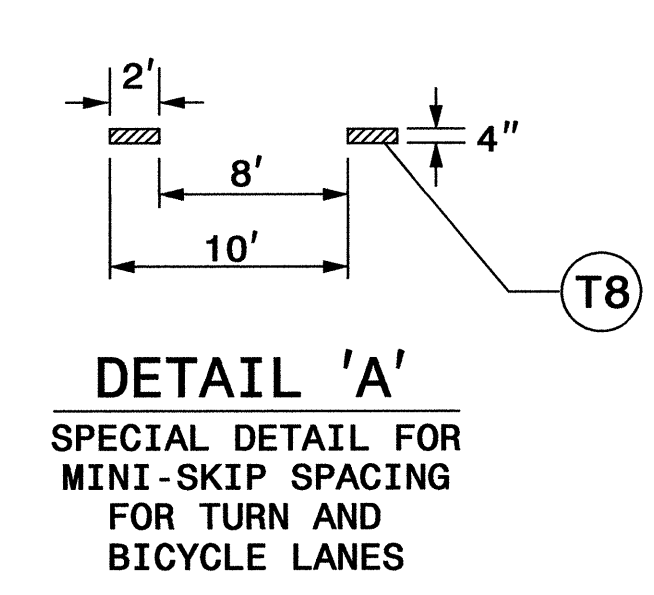

**PAVEMENT MARKING DETAIL**

P:\APP-2010\13136\U3306\Traffic\Signing\CADD\PMP\U3306.tc.pmp\_3.dgn  
 12/27/07  
 wmd@brw.com

|                   |                     |
|-------------------|---------------------|
| TIP NO.<br>U-3306 | SHEET NO.<br>PMP-3a |
| APPROVED: _____   |                     |
| DATE: _____       |                     |
| SEAL              |                     |

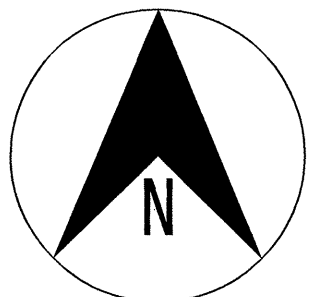
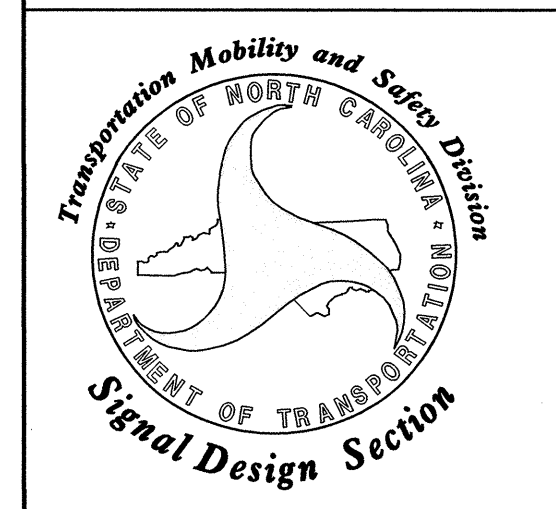
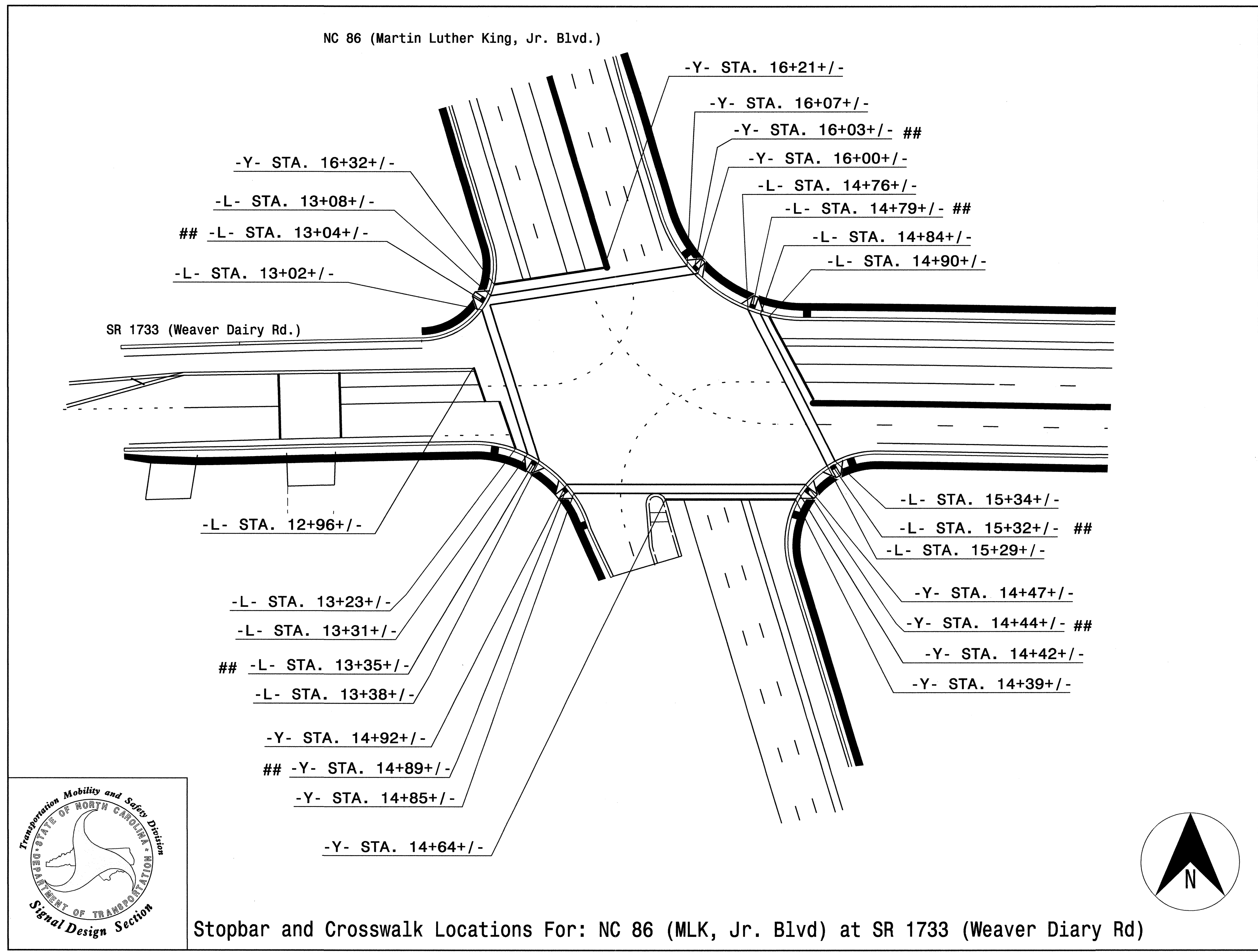
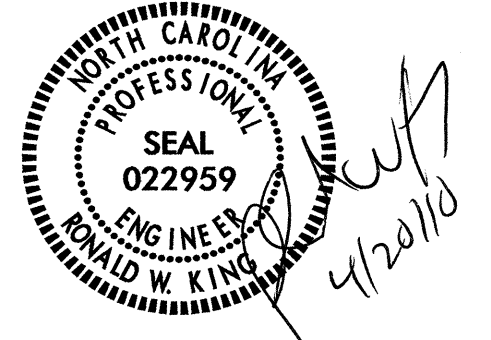

## Center of Curb Ramp

STOP BAR, CROSSWALK and CURB RAMP LOCATIONS

PAVEMENT MARKING DETAIL

19-Apr-2010 13:37 U:\123065\Traffic\Signing\CADD\PMU-U-3306-Sgn-PMP-3a.dgn  
 wml@brw.com 12/23/07

|                   |                    |
|-------------------|--------------------|
| TIP NO.<br>U-3306 | SHEET NO.<br>PMP-4 |
| APPROVED: _____   |                    |
| DATE: _____       |                    |
| SEAL              |                    |

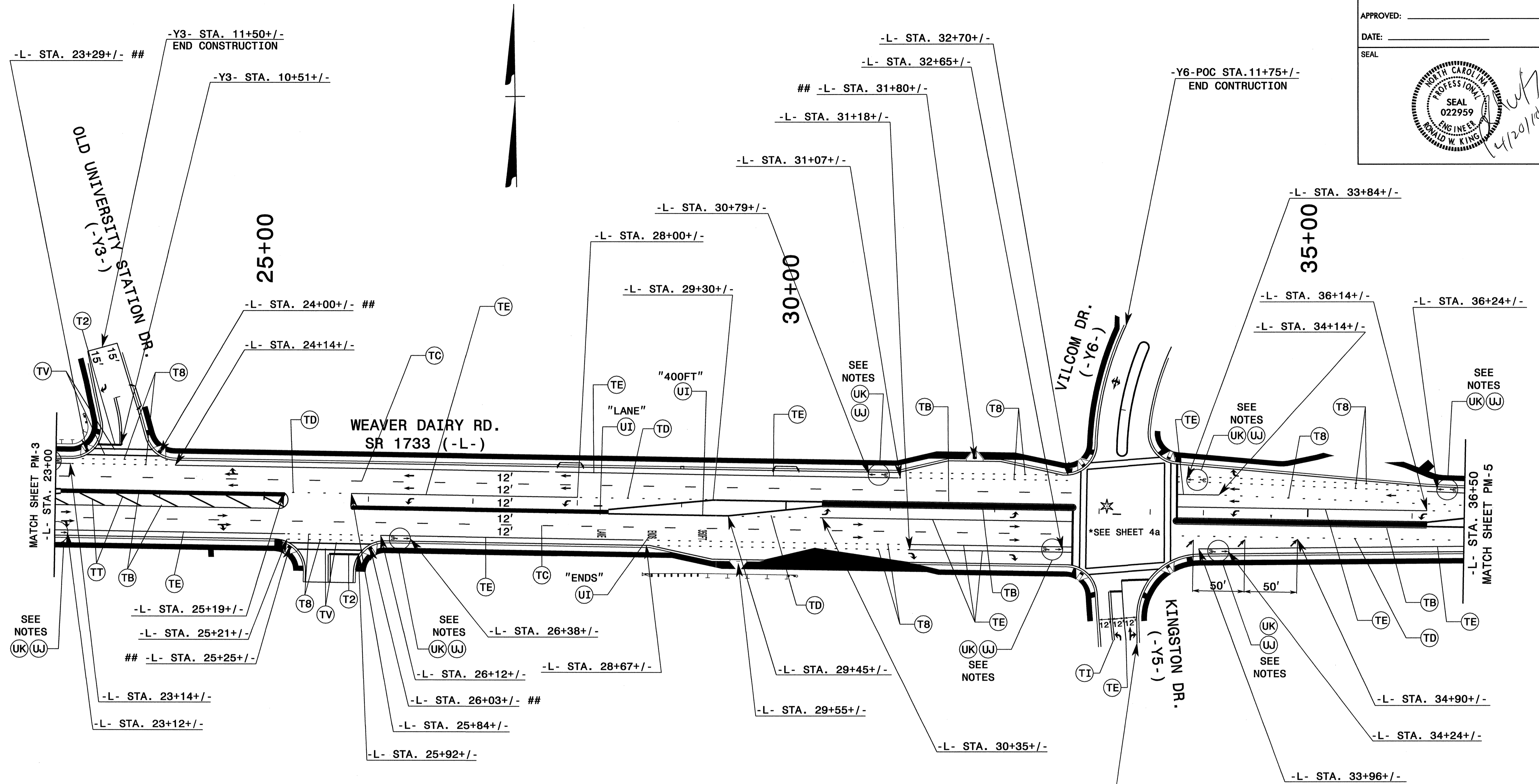

**NOTES**

|                                |                               |   |  |
|--------------------------------|-------------------------------|---|--|
| <br>LEFT TURN<br>ARROW<br>(UA) | <br>STRAIGHT<br>ARROW<br>(UC) | <br>RIGHT TURN<br>ARROW<br>(UB)   | <br>STRAIGHT/<br>LEFT/RIGHT<br>COMBO ARROW<br>(UG) |
|                                |                               | UNLESS OTHERWISE SHOWN, PAVEMENT MARKINGS, SYMBOLS, CHARACTERS, AND MARKERS SHALL BE PLACED ACCORDING TO ROADWAY STANDARD DRAWING NO. 1205.01, 1205.02, 1205.04, 1205.05, 1205.06, 1205.07, 1205.08, 1205.09, 1250.01, 1251.01. |  |

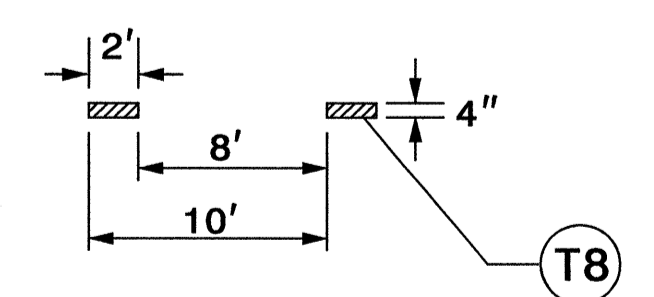

**DETAIL 'A'**  
SPECIAL DETAIL FOR  
MINI-SKIP SPACING  
FOR TURN AND  
BICYCLE LANES

**PAVEMENT MARKING DETAIL**

19-APR-2010 13:41  
 P:\TIP\Projects\1217307\1217307.dgn  
 wmcbrw

|                   |                     |
|-------------------|---------------------|
| TIP NO.<br>U-3306 | SHEET NO.<br>PMP-4a |
| APPROVED: _____   |                     |
| DATE: _____       |                     |
| SEAL              |                     |

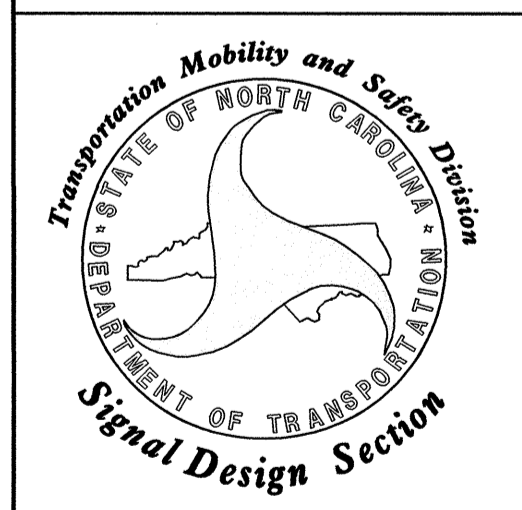
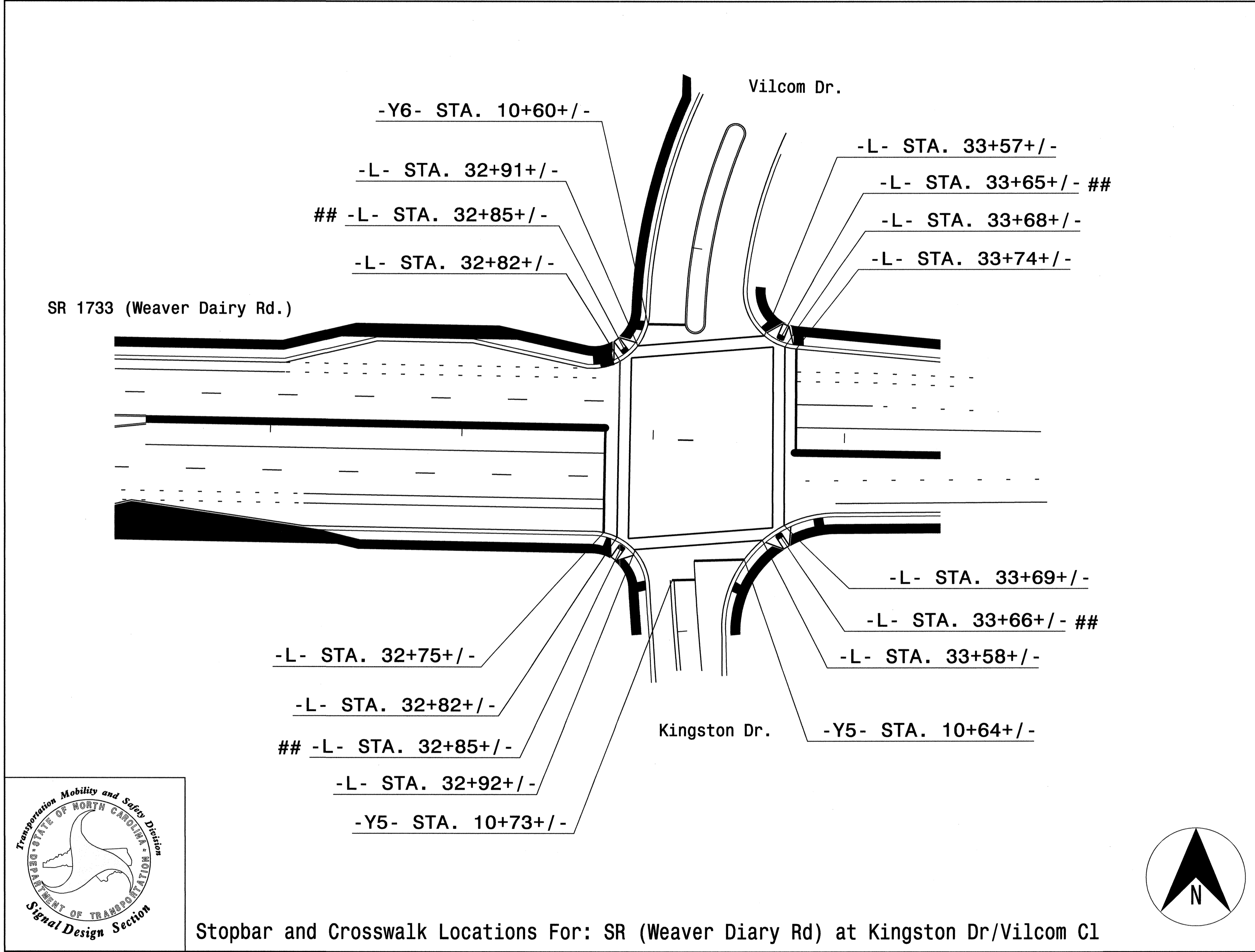

## Center of Curb Ramp

STOP BAR, CROSSWALK and CURB RAMP LOCATIONS

PAVEMENT MARKING DETAIL

19-APR-2010 15:47  
 P:\TIP\3306\T-Office\Signing\CADD\PMU-U-3306.PMP-4a.dgn  
 wmdbr-ev AT E277307

|                   |                    |
|-------------------|--------------------|
| TIP NO.<br>U-3306 | SHEET NO.<br>PMP-5 |
| APPROVED: _____   |                    |
| DATE: _____       |                    |
| SEAL              |                    |

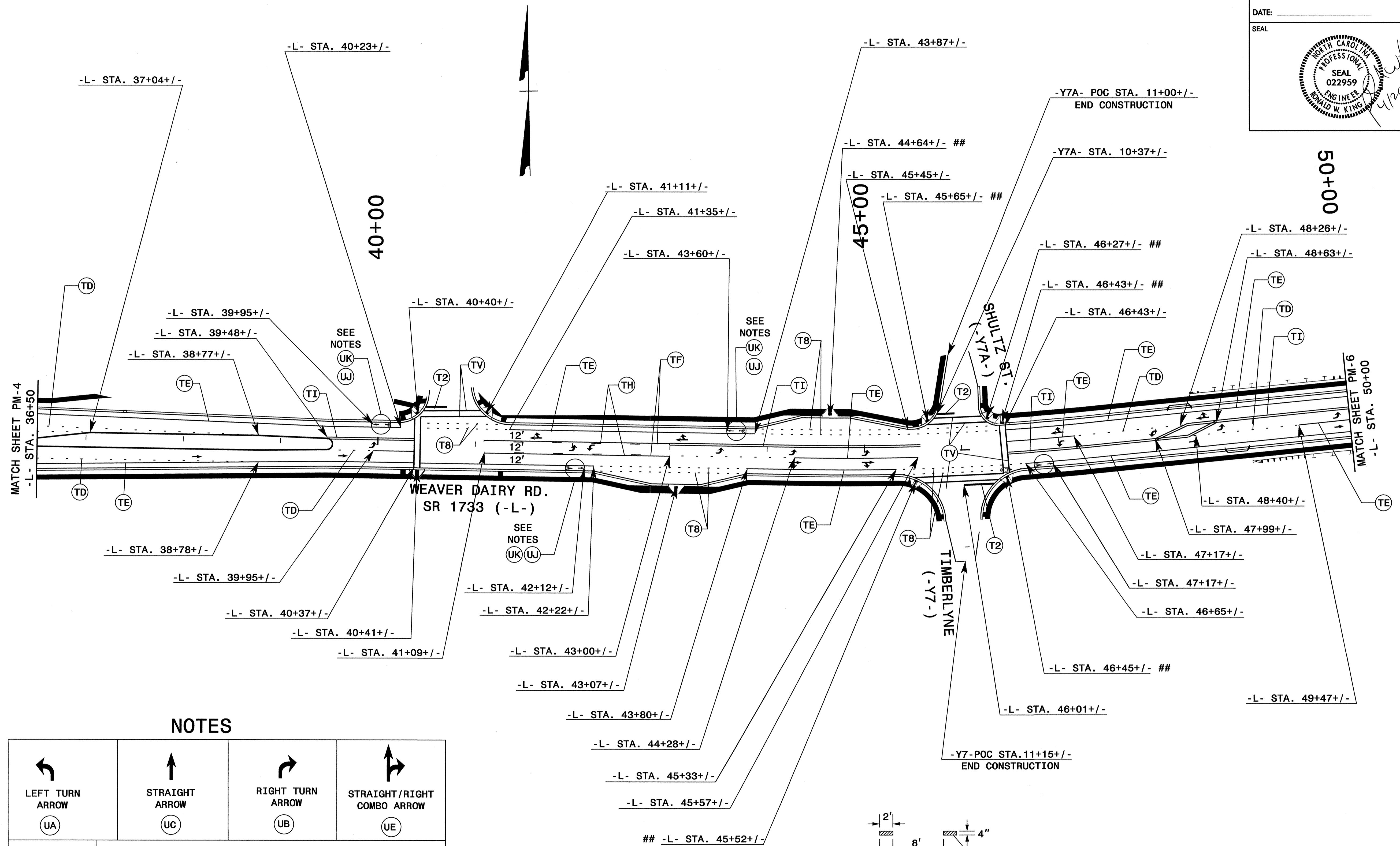

**NOTES**

|                                |                               |  |   |
|--------------------------------|-------------------------------|--|---|
| <br>LEFT TURN<br>ARROW<br>(UA) | <br>STRAIGHT<br>ARROW<br>(UC) | <br>RIGHT TURN<br>ARROW<br>(UB)  | <br>STRAIGHT/RIGHT<br>COMBO ARROW<br>(UE) |
| <br>UK                         | <br>UJ                        | UNLESS OTHERWISE SHOWN, PAVEMENT MARKINGS, SYMBOLS, CHARACTERS, AND MARKERS SHALL BE PLACED ACCORDING TO ROADWAY STANDARD DRAWING NO. 1205.01, 1205.02, 1205.04, 1205.05, 1205.06, 1205.07, 1205.08, 1250.01, 1251.01. |   |

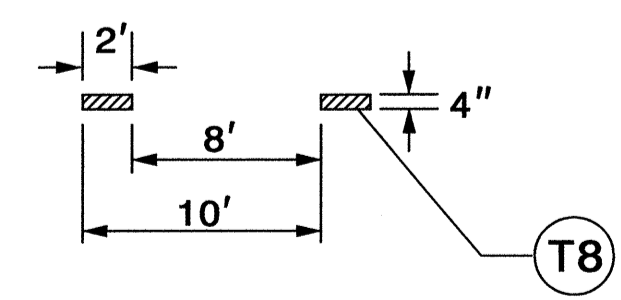

**DETAIL 'A'**  
SPECIAL DETAIL FOR  
MINI-SKIP SPACING  
FOR TURN AND  
BICYCLE LANES

**PAVEMENT MARKING DETAIL**

19-APR-2010 15:53  
 P:\TIP\U3306\Traffic\Signing\CADD\PM-5.dgn  
 wmdrew

|                   |                    |
|-------------------|--------------------|
| TIP NO.<br>U-3306 | SHEET NO.<br>PMP-6 |
| APPROVED: _____   |                    |
| DATE: _____       |                    |
| SEAL              |                    |

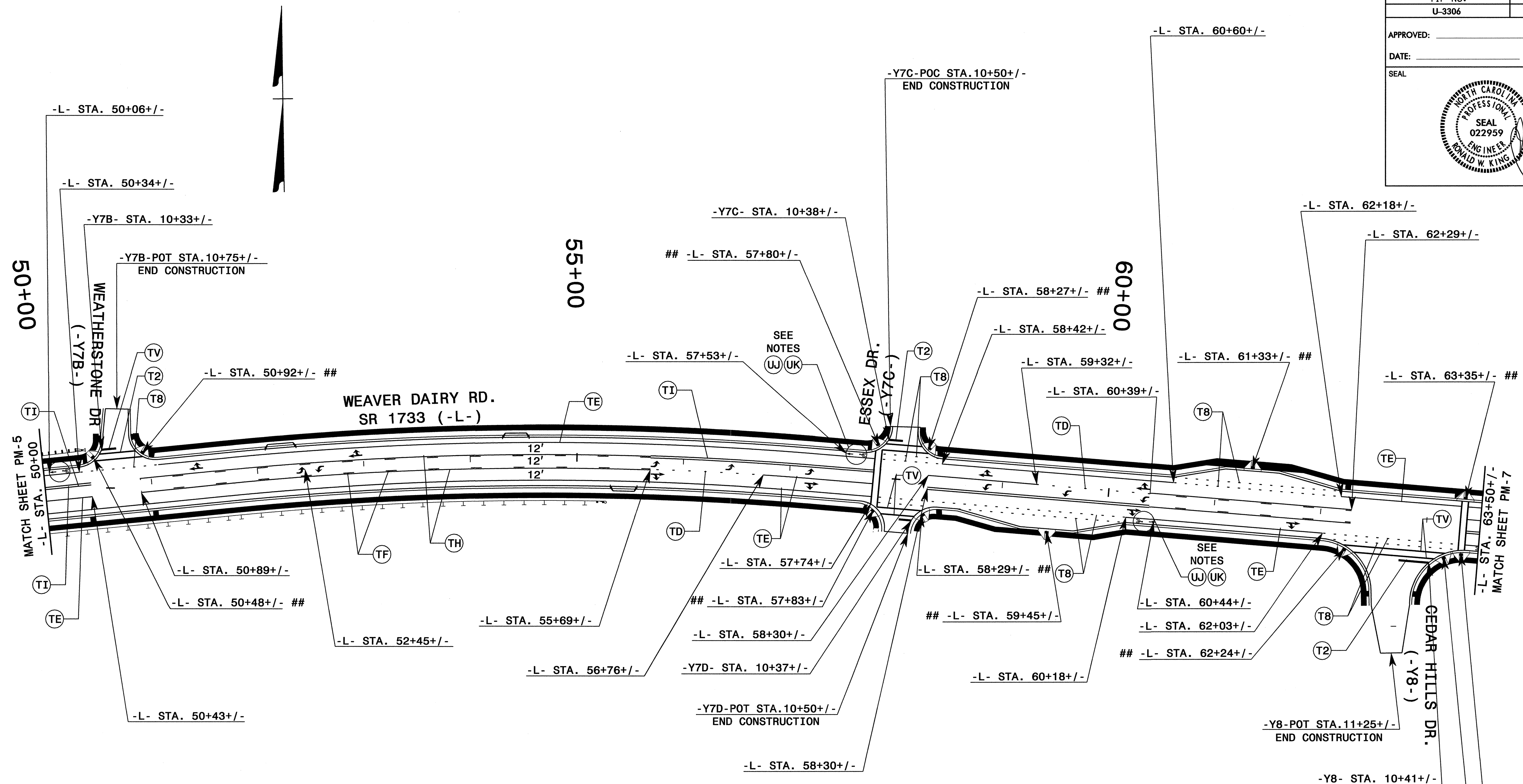

**NOTES**

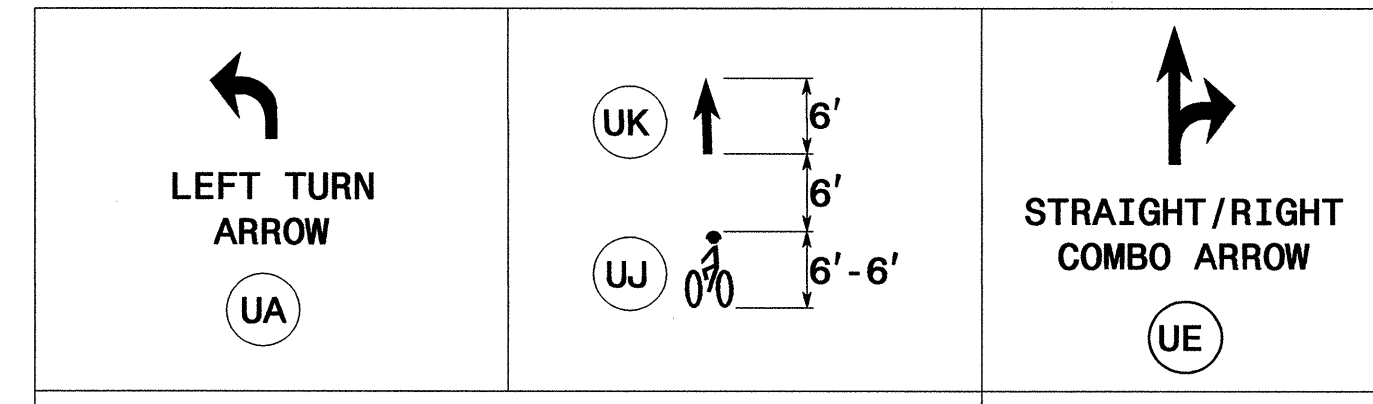

UNLESS OTHERWISE SHOWN, PAVEMENT MARKINGS, SYMBOLS, CHARACTERS, AND MARKERS SHALL BE PLACED ACCORDING TO ROADWAY STANDARD DRAWING NO. 1205.01, 1205.02, 1205.04, 1205.05, 1205.06, 1205.07, 1205.08, 1250.01, 1251.01.

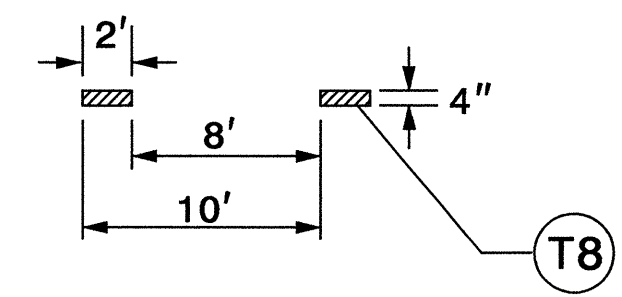

**DETAIL 'A'**  
SPECIAL DETAIL FOR MINI-SKIP SPACING FOR TURN AND BICYCLE LANES

**PAVEMENT MARKING DETAIL**

19-APR-2010 13:55  
 P:\Projects\U3306\Traffic\Signing\CADD\PM-6.dgn  
 vmdbrav



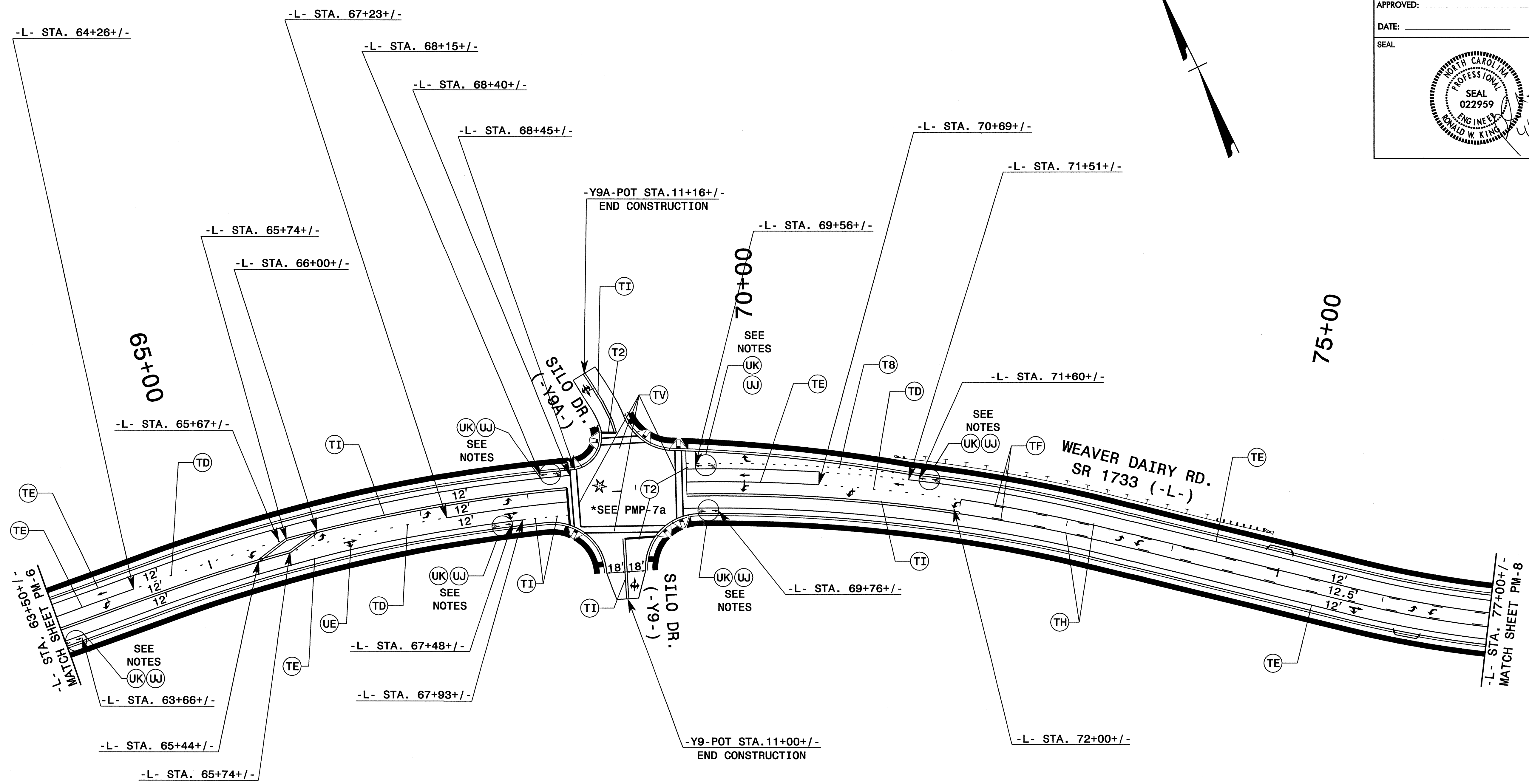

**NOTES**

|                         |                        |  |                                    |   |
|-------------------------|------------------------|--|------------------------------------|---|
|                         |                        |  |                                    |   |
| LEFT TURN ARROW<br>(UA) | STRAIGHT ARROW<br>(UC) | RIGHT TURN ARROW<br>(UB)   | STRAIGHT/RIGHT COMBO ARROW<br>(UE) | LEFT/STRAIGHT/RIGHT COMBO ARROW<br>(UG) |
|                         |                        | UNLESS OTHERWISE SHOWN, PAVEMENT MARKINGS, SYMBOLS, CHARACTERS, AND MARKERS SHALL BE PLACED ACCORDING TO ROADWAY STANDARD DRAWING NO. 1205.01, 1205.02, 1205.04, 1205.05, 1205.06, 1205.07, 1205.08, 1250.01, 1251.01. |                                    |   |

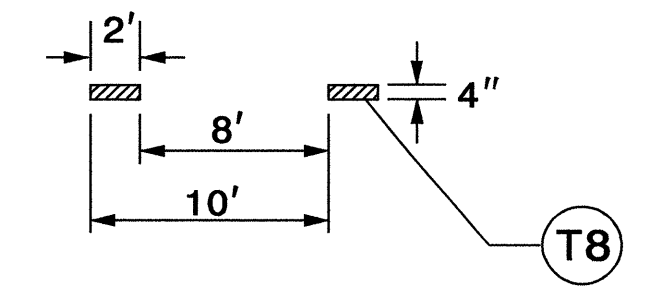

**DETAIL 'A'**  
SPECIAL DETAIL FOR MINI-SKIP SPACING FOR TURN AND BICYCLE LANES

**PAVEMENT MARKING DETAIL**

19-APR-2010 13:56 U:\3306\Traffic\Signing\CADD\PM-7.dgn  
 P:\Projects\12277807\macedonia.plt

|                   |                     |
|-------------------|---------------------|
| TIP NO.<br>U-3306 | SHEET NO.<br>PMP-7a |
| APPROVED: _____   |                     |
| DATE: _____       |                     |
| SEAL              |                     |
|                   |                     |

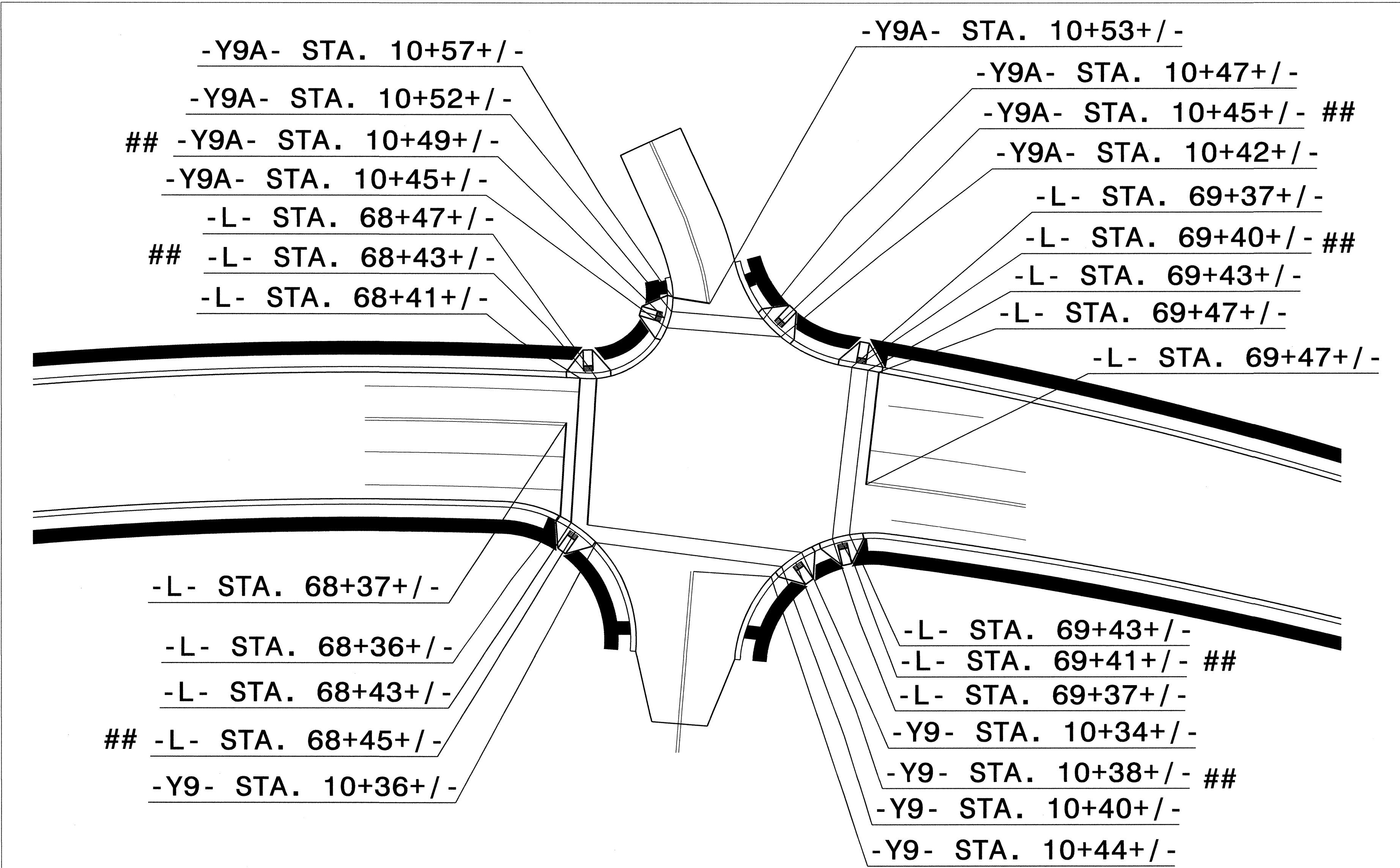

-Y9A- STA. 10+57+/-  
 -Y9A- STA. 10+52+/-  
 ## -Y9A- STA. 10+49+/-  
 -Y9A- STA. 10+45+/-  
 -L- STA. 68+47+/-  
 ## -L- STA. 68+43+/-  
 -L- STA. 68+41+/-

-Y9A- STA. 10+53+/-  
 -Y9A- STA. 10+47+/-  
 -Y9A- STA. 10+45+/- ##  
 -Y9A- STA. 10+42+/-  
 -L- STA. 69+37+/-  
 -L- STA. 69+40+/- ##  
 -L- STA. 69+43+/-  
 -L- STA. 69+47+/-  
 -L- STA. 69+47+/-

-L- STA. 68+37+/-  
 -L- STA. 68+36+/-  
 -L- STA. 68+43+/-  
 ## -L- STA. 68+45+/-  
 -Y9- STA. 10+36+/-

-L- STA. 69+43+/-  
 -L- STA. 69+41+/- ##  
 -L- STA. 69+37+/-  
 -Y9- STA. 10+34+/-  
 -Y9- STA. 10+38+/- ##  
 -Y9- STA. 10+40+/-  
 -Y9- STA. 10+44+/-

Stopbar and Crosswalk Locations For: SR 1733 (Weaver Diary Rd) at Silo Drive

## Center of Curb Ramp

STOP BAR, CROSSWALK and CURB RAMP LOCATIONS

PAVEMENT MARKING DETAIL

I:\APR2010\_13459  
 P:\TIP\Projects\AT\TE247\07  
 vmd\ebrev  
 I:\APR2010\_13459\U3306\Traffic\Signing\CADD\MP-U-3306.PMP\_7a.dgn

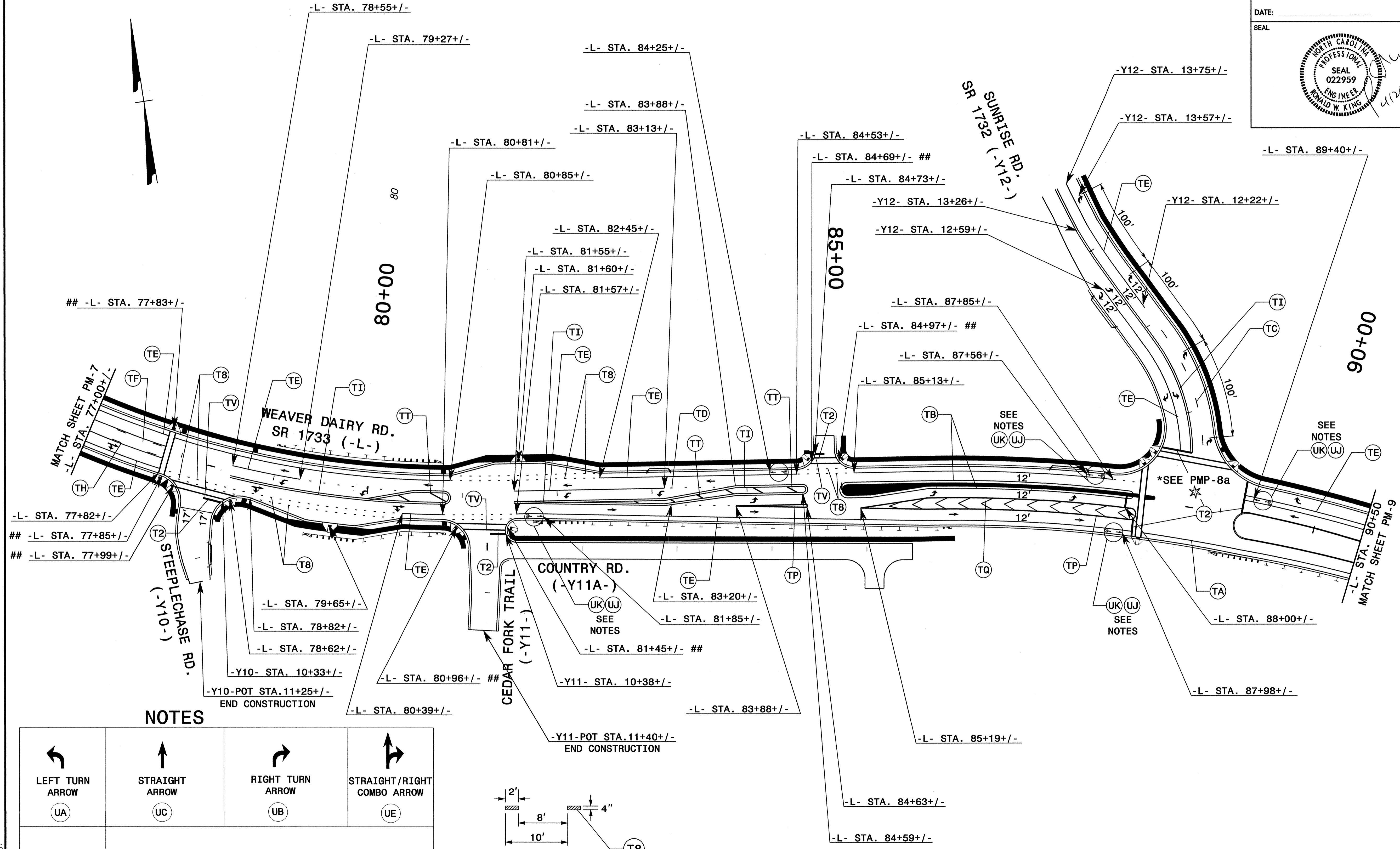

**NOTES**

|                          |                         |                           |                                     |
|--------------------------|-------------------------|---------------------------|-------------------------------------|
|                          |                         |                           |                                     |
| LEFT TURN<br>ARROW<br>UA | STRAIGHT<br>ARROW<br>UC | RIGHT TURN<br>ARROW<br>UB | STRAIGHT/RIGHT<br>COMBO ARROW<br>UE |

UNLESS OTHERWISE SHOWN, PAVEMENT MARKINGS, SYMBOLS, CHARACTERS, AND MARKERS SHALL BE PLACED ACCORDING TO ROADWAY STANDARD DRAWING NO. 1205.01, 1205.02, 1205.04, 1205.05, 1205.06, 1205.07, 1205.08, 1205.09, 1205.10, 1250.01, 1251.01, 1253.01.

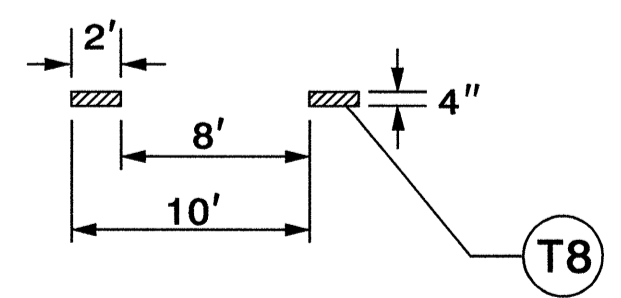

**DETAIL 'A'**  
SPECIAL DETAIL FOR  
MINI-SKIP SPACING  
FOR TURN AND  
BICYCLE LANES

**PAVEMENT MARKING DETAIL**

I:\9-APP-2010-1401  
 P:\TIP\Projects\U3306\Traffic\Signing\CADD\PM\U3306\_TC\_PMP-8.dgn  
 wmdelbrav AT 12/24/07

|                 |           |
|-----------------|-----------|
| TIP NO.         | SHEET NO. |
| U-3306          | PMP-8a    |
| APPROVED: _____ |           |
| DATE: _____     |           |
| SEAL            |           |
|                 |           |

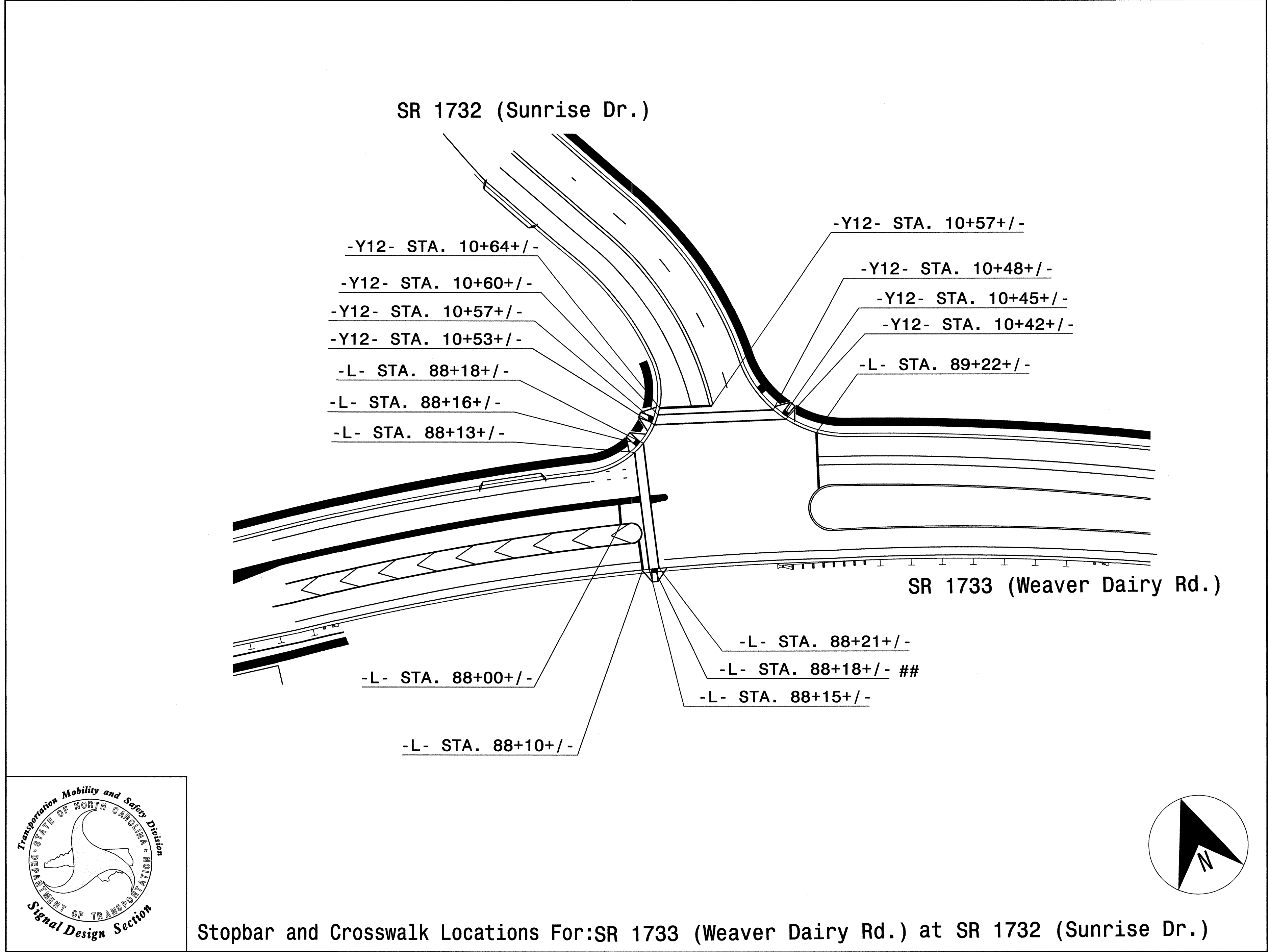

- Y12- STA. 10+64+/-
- Y12- STA. 10+60+/-
- Y12- STA. 10+57+/-
- Y12- STA. 10+53+/-
- L- STA. 88+18+/-
- L- STA. 88+16+/-
- L- STA. 88+13+/-
- Y12- STA. 10+57+/-
- Y12- STA. 10+48+/-
- Y12- STA. 10+45+/-
- Y12- STA. 10+42+/-
- L- STA. 89+22+/-
- L- STA. 88+21+/-
- L- STA. 88+18+/- ##
- L- STA. 88+15+/-
- L- STA. 88+10+/-
- L- STA. 88+00+/-

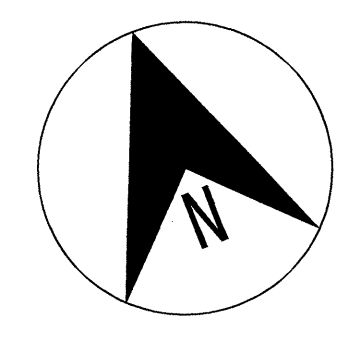
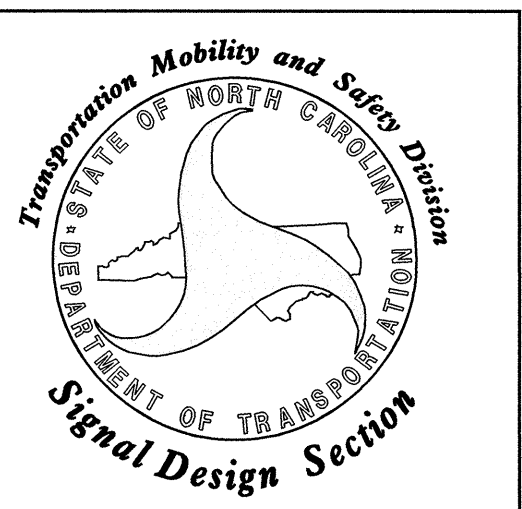

## Center of Curb Ramp

STOP BAR, CROSSWALK and CURB RAMP LOCATIONS

PAVEMENT MARKING DETAIL

I:\9-APR-2010 14:02  
 P:\TIP\Projects\U3306\Traffic\Signing\CADD\PMU-U-3306\_PMP-8a.dgn  
 wmdobrev AT TE247907

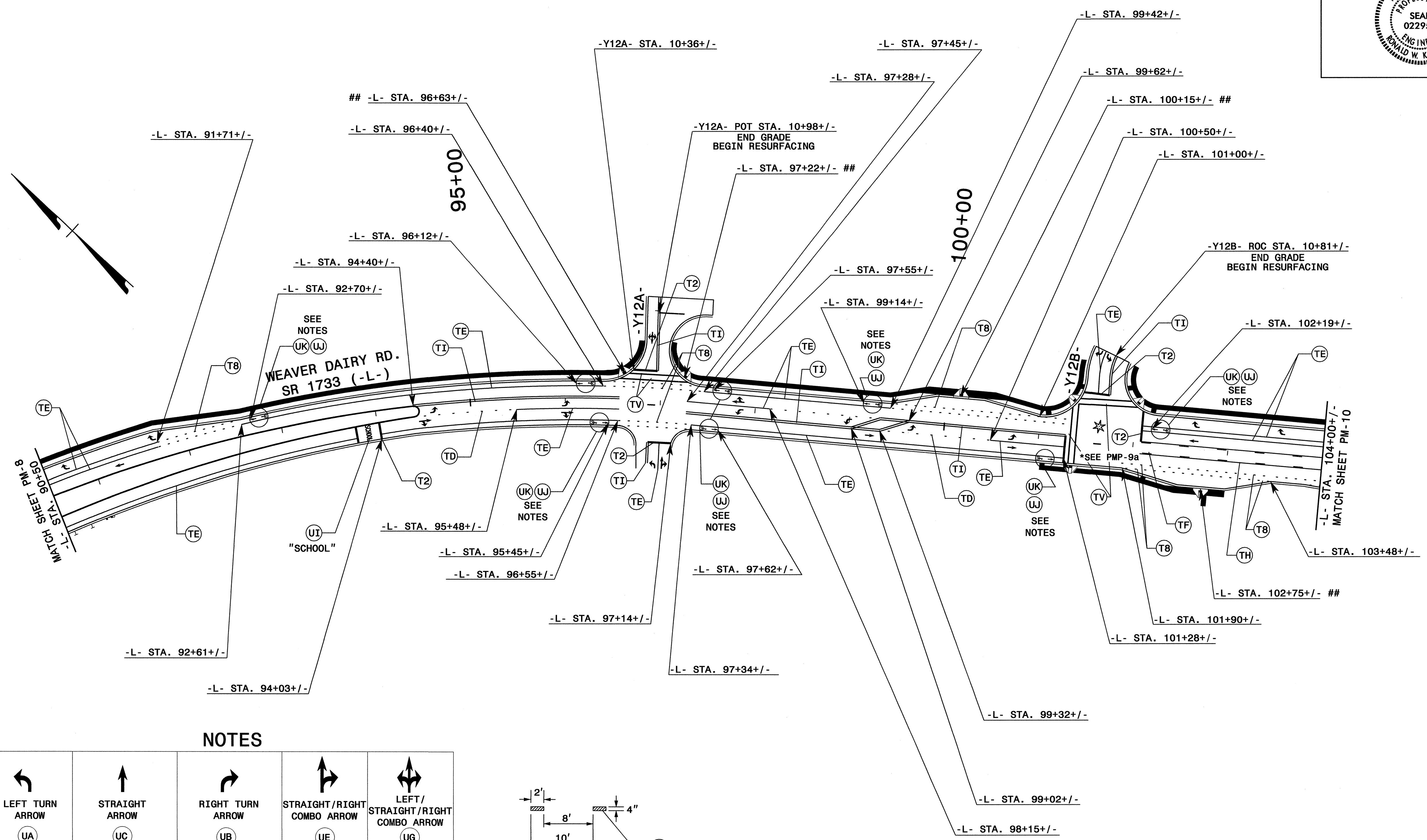
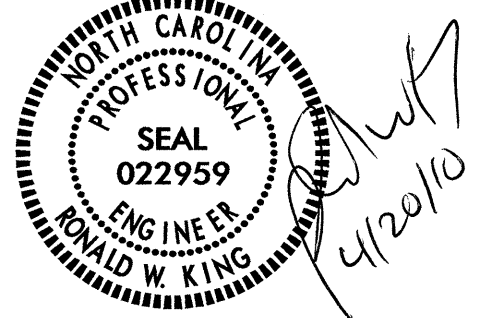

**NOTES**

|                            |                           |   |                                       |  |
|----------------------------|---------------------------|---|---------------------------------------|--|
|                            |                           |   |                                       |  |
| LEFT TURN<br>ARROW<br>(UA) | STRAIGHT<br>ARROW<br>(UC) | RIGHT TURN<br>ARROW<br>(UB)   | STRAIGHT/RIGHT<br>COMBO ARROW<br>(UE) | LEFT/<br>STRAIGHT/RIGHT<br>COMBO ARROW<br>(UG) |
|                            |                           | UNLESS OTHERWISE SHOWN, PAVEMENT MARKINGS, SYMBOLS,<br>CHARACTERS, AND MARKERS SHALL BE PLACED ACCORDING TO<br>ROADWAY STANDARD DRAWING NO. 1205.01, 1205.02, 1205.04,<br>1205.05, 1205.06, 1205.07, 1205.08, 1205.10, 1250.01,<br>1251.01. |                                       |  |

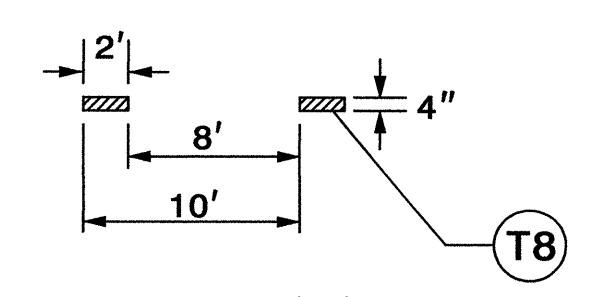

**DETAIL 'A'**  
SPECIAL DETAIL FOR  
MINI-SKIP SPACING  
FOR TURN AND  
BICYCLE LANES

**PAVEMENT MARKING DETAIL**

IS:\PMP-9\1407\13306\Traffic\Signing\CADD\PM-9.dgn  
 P:\PMP-9\1407\13306\Traffic\Signing\CADD\PM-9.dgn  
 AT 12:27:07  
 vmd:brv

|                   |                     |
|-------------------|---------------------|
| TIP NO.<br>U-3306 | SHEET NO.<br>PMP-9a |
| APPROVED: _____   |                     |
| DATE: _____       |                     |
| SEAL              |                     |
|                   |                     |

East Chapel Hill High School

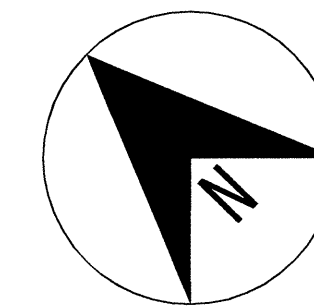
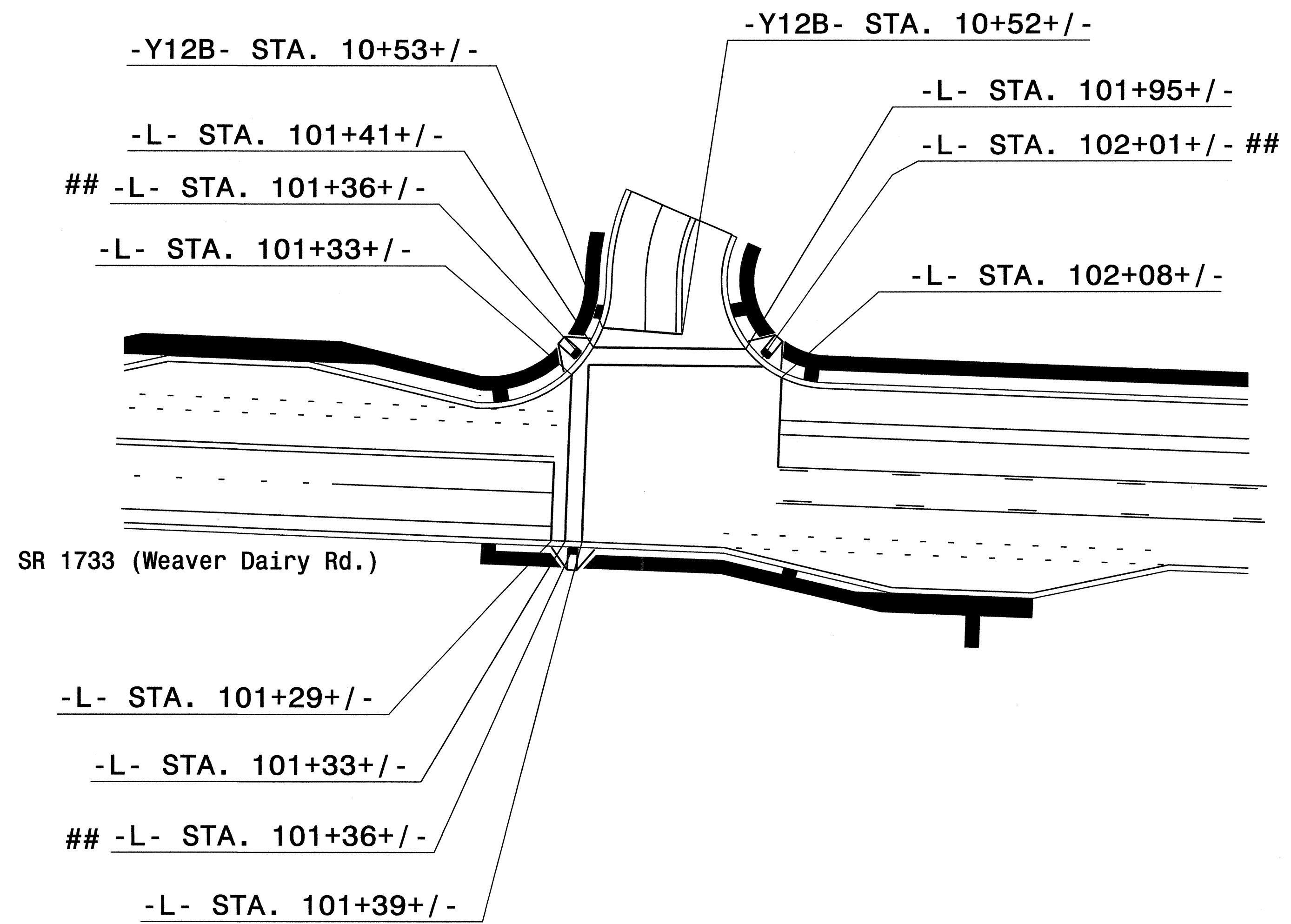

Stopbar and Crosswalk Locations For: SR 1733(Weaver Dairy Rd) at E. Chapel Hill High School

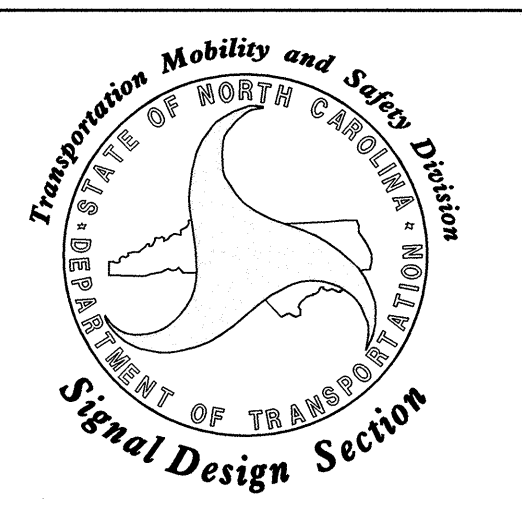

## Center of Curb Ramp

STOP BAR, CROSSWALK and CURB RAMP LOCATIONS

PAVEMENT MARKING DETAIL

|                   |                     |
|-------------------|---------------------|
| TIP NO.<br>U-3306 | SHEET NO.<br>PMP-10 |
| APPROVED: _____   |                     |
| DATE: _____       |                     |
| SEAL              |                     |

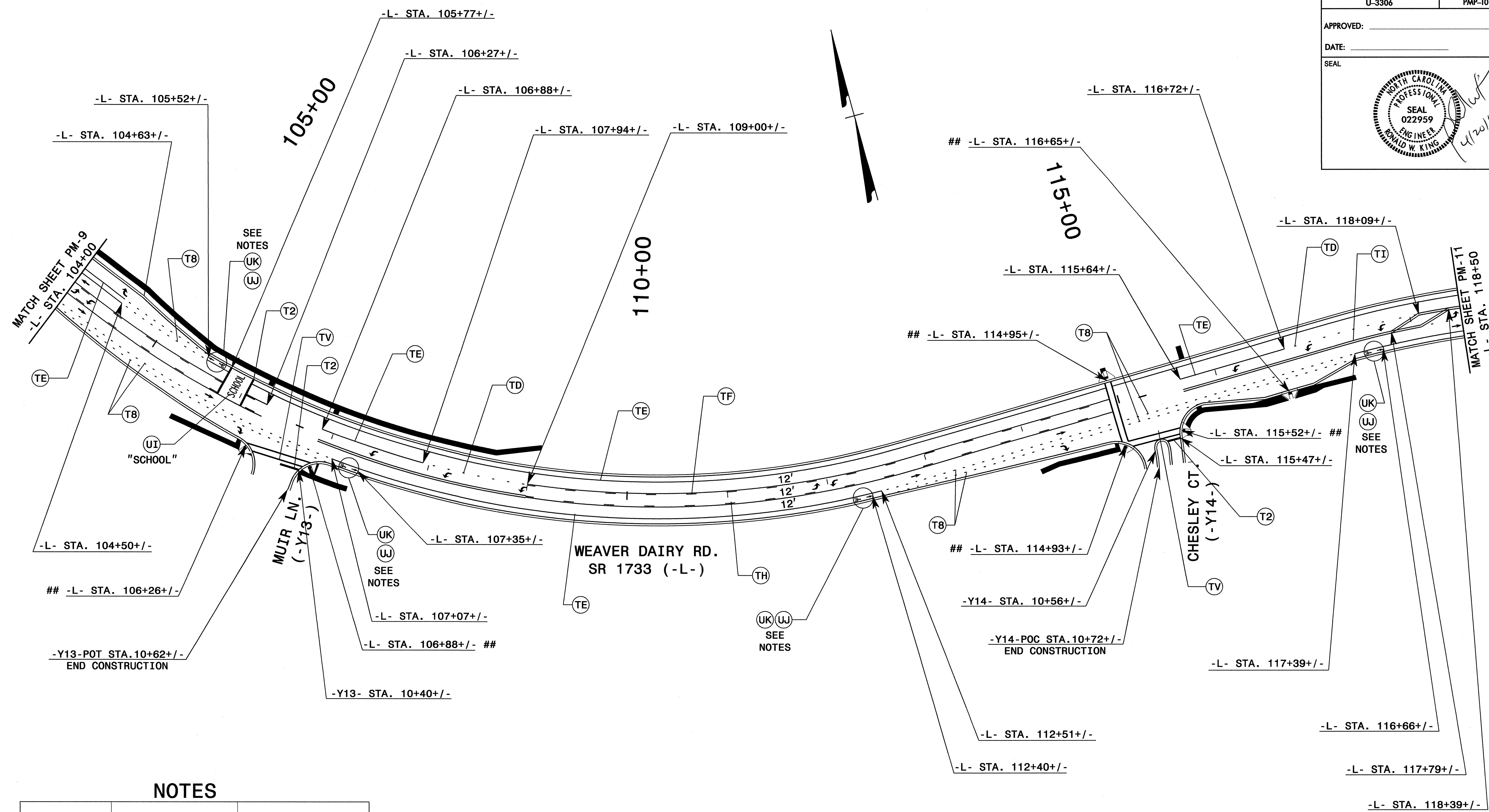

**NOTES**

|                                |   |                                 |
|--------------------------------|---|---------------------------------|
| <br>LEFT TURN<br>ARROW<br>(UA) | <br>STRAIGHT<br>ARROW<br>(UC)   | <br>RIGHT TURN<br>ARROW<br>(UB) |
| <br>↑ 6'<br><br>↑ 6'-6'        | UNLESS OTHERWISE SHOWN, PAVEMENT MARKINGS, SYMBOLS, CHARACTERS, AND MARKERS SHALL BE PLACED ACCORDING TO ROADWAY STANDARD DRAWING NO. 1205.01, 1205.02, 1205.04, 1205.05, 1205.06, 1205.07, 1205.08, 1205.10, 1250.01, 1251.01. |                                 |

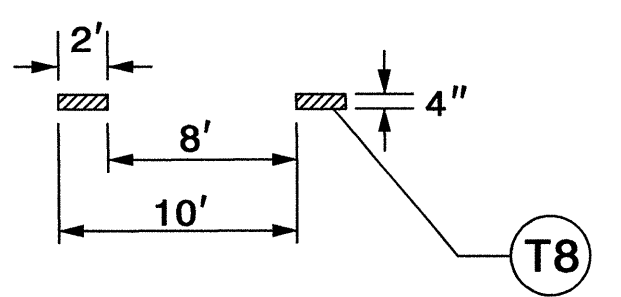

**DETAIL 'A'**  
SPECIAL DETAIL FOR  
MINI-SKIP SPACING  
FOR TURN AND  
BICYCLE LANES

**PAVEMENT MARKING DETAIL**

IP-APR-2010 14:05  
 P:\TIP\Projects\U3306\Traffic\Signing\CADD\PM-10.dgn  
 wmdobrev AT TE247907

|                   |                     |
|-------------------|---------------------|
| TIP NO.<br>U-3306 | SHEET NO.<br>PMP-11 |
| APPROVED: _____   |                     |
| DATE: _____       |                     |
| SEAL              |                     |

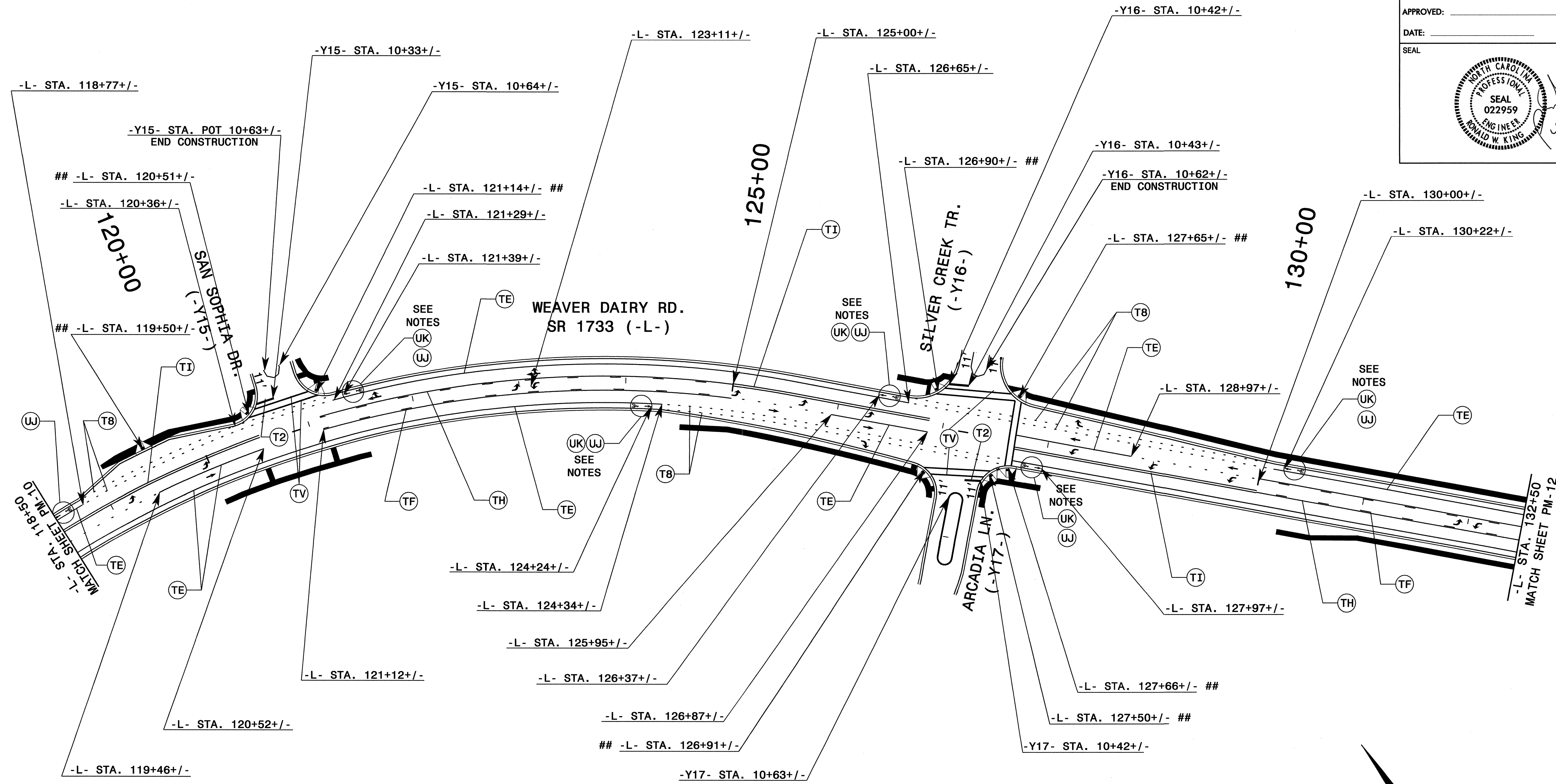

**NOTES**

|   |                               |  |                               |
|---|-------------------------------|--|-------------------------------|
| <br>LEFT TURN<br>ARROW<br>(UA)  | <br>STRAIGHT<br>ARROW<br>(UC) | <br>STRAIGHT/RIGHT<br>COMBO<br>ARROW<br>(UE) | <br>(UK) ↑ 6'<br>(UJ) ↗ 6'-6' |
| UNLESS OTHERWISE SHOWN, PAVEMENT MARKINGS, SYMBOLS, CHARACTERS, AND MARKERS SHALL BE PLACED ACCORDING TO ROADWAY STANDARD DRAWING NO. 1205.01, 1205.02, 1205.04, 1205.05, 1205.06, 1205.07, 1205.08, 1205.09, 1205.10, 1250.01, 1251.01, 1253.01. |                               |  |                               |

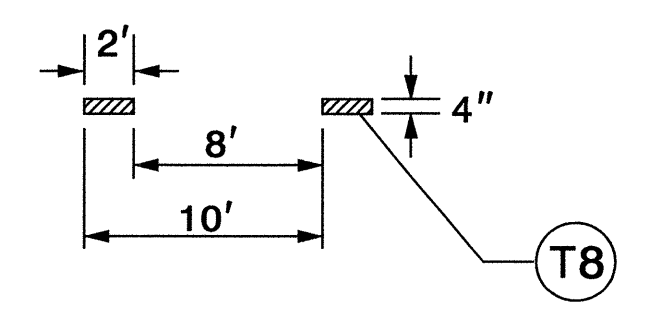

**DETAIL 'A'**  
SPECIAL DETAIL FOR  
MINI-SKIP SPACING  
FOR TURN AND  
BICYCLE LANES

**PAVEMENT MARKING DETAIL**

IS:\APP-2010\1457  
 P:\TIP\Projects\U-3306\Traffic\Signing\CADD\PMU\U3306\_TC\_PMP\_11.dgn  
 wmdbr 04/21/10



|                   |                     |
|-------------------|---------------------|
| TIP NO.<br>U-3306 | SHEET NO.<br>PMP-12 |
| APPROVED: _____   |                     |
| DATE: _____       |                     |
| SEAL              |                     |

R. King  
4/2010

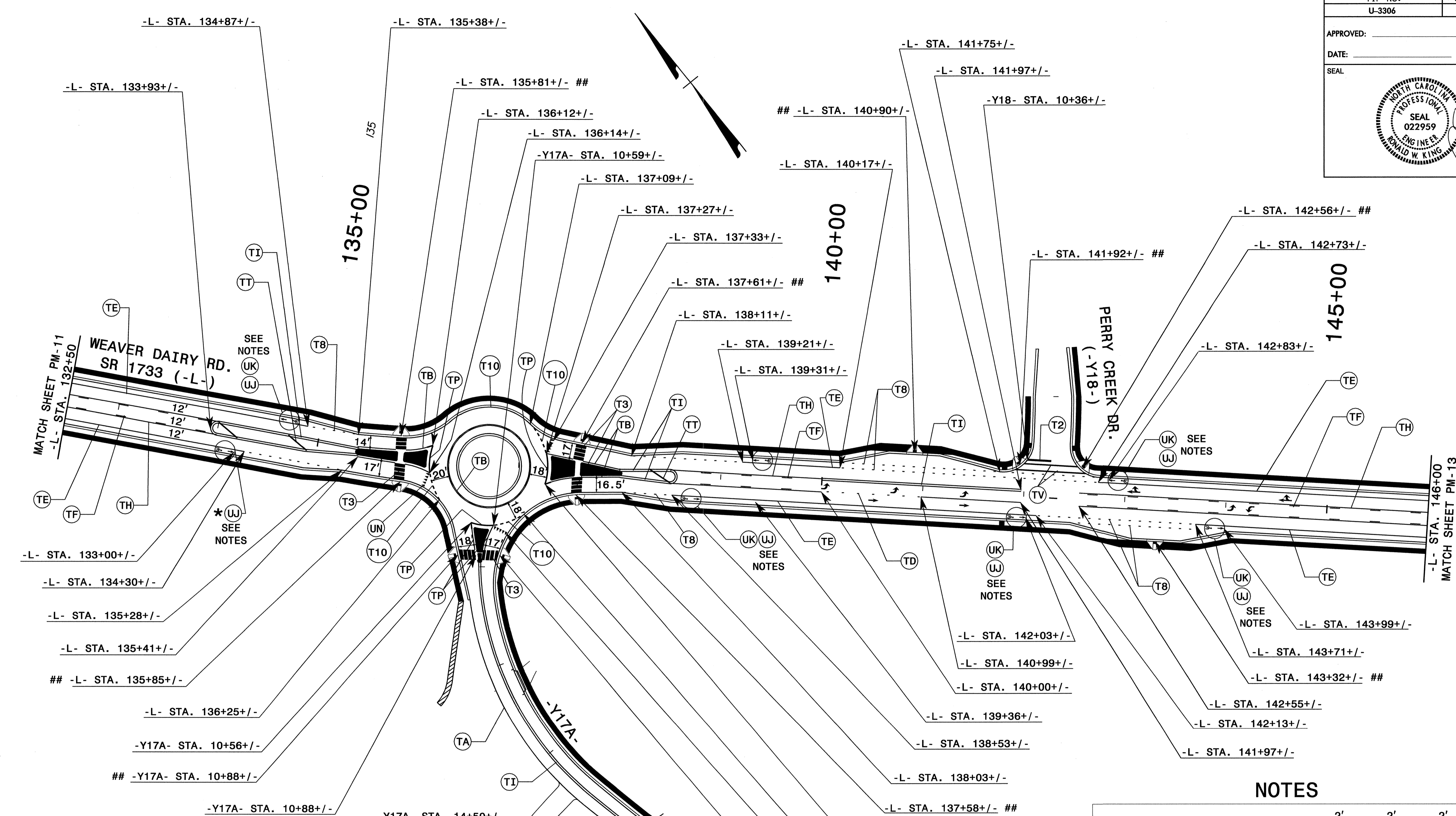

### NOTES

|                             |                            |  |                  |
|-----------------------------|----------------------------|--|------------------|
| <br>LEFT TURN ARROW<br>(UA) | <br>STRAIGHT ARROW<br>(UC) | <br>STRAIGHT/RIGHT COMBO ARROW<br>(UE) | <br>(UK)<br>(UJ) |
|-----------------------------|----------------------------|--|------------------|

UNLESS OTHERWISE SHOWN, PAVEMENT MARKINGS, SYMBOLS, CHARACTERS, AND MARKERS SHALL BE PLACED ACCORDING TO ROADWAY STANDARD DRAWING NO. 1205.01, 1205.02, 1205.04, 1205.05, 1205.06, 1205.07, 1205.08, 1205.09, 1205.10, 1250.01, 1251.01, 1253.01.

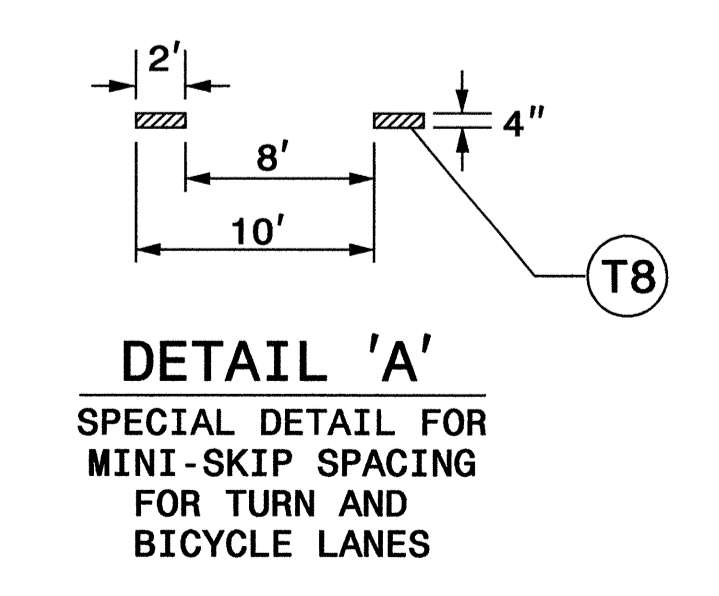

### NOTES

SPECIAL DETAIL FOR YIELD LINE MINISKIP - T10  
PAYMENT FOR YIELD LINE MINISKIP WILL BE BASED ON POLYUREA (24", 20 MILS)

SPECIAL DETAIL FOR YIELD LINE SHARK TEETH - UN  
PAYMENT FOR YIELD LINE SHARK TEETH WILL BE BASED ON THERMOPLASTIC SYMBOL

## PAVEMENT MARKING DETAIL

19-APP-2010 14409  
 P:\TIP\Projects\U3306\Traffic\Signmg\CADD\PMU3306L\_TC\_PMP\_12.dgn  
 wmdbr@ex AT TE247907

|                   |                     |
|-------------------|---------------------|
| TIP NO.<br>U-3306 | SHEET NO.<br>PMP-13 |
| APPROVED: _____   |                     |
| DATE: _____       |                     |
| SEAL              |                     |

*R. King*  
4/20/10

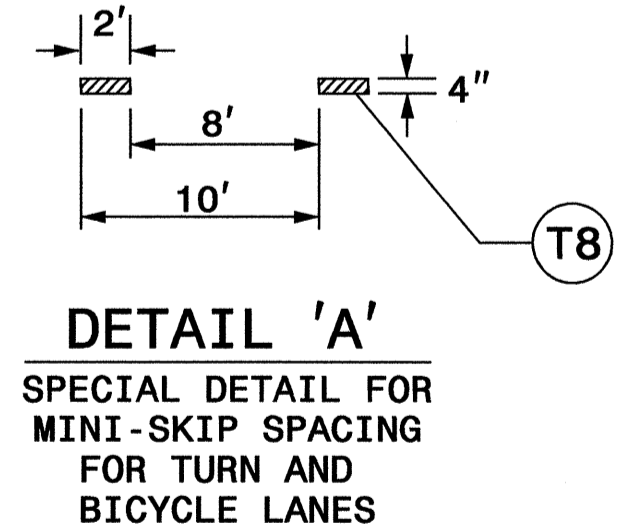
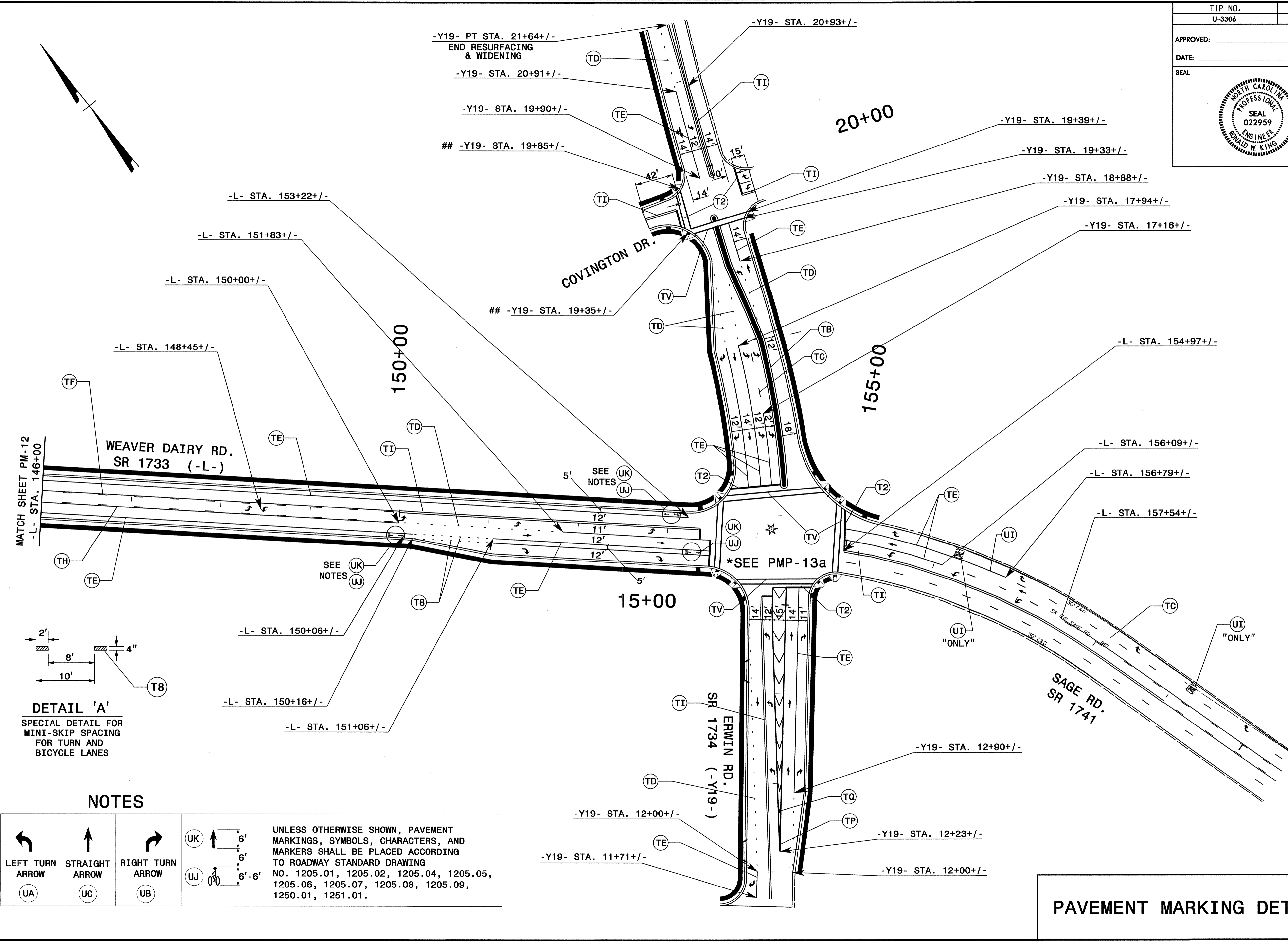

**NOTES**

|                              |                             |                               |        |        |
|------------------------------|-----------------------------|-------------------------------|--------|--------|
| <br>LEFT TURN<br>ARROW<br>UA | <br>STRAIGHT<br>ARROW<br>UC | <br>RIGHT TURN<br>ARROW<br>UB | <br>UK | <br>UJ |
|------------------------------|-----------------------------|-------------------------------|--------|--------|

UNLESS OTHERWISE SHOWN, PAVEMENT MARKINGS, SYMBOLS, CHARACTERS, AND MARKERS SHALL BE PLACED ACCORDING TO ROADWAY STANDARD DRAWING NO. 1205.01, 1205.02, 1205.04, 1205.05, 1205.06, 1205.07, 1205.08, 1205.09, 1250.01, 1251.01.

**PAVEMENT MARKING DETAIL**

19 APR 2010 14:40 UN3306.T\Fffic\Signmg\CADD\PMP\U3306.TC.PMP.13.dgn  
 P:\TIP\U3306.T\Fffic\Signmg\CADD\PMP\U3306.TC.PMP.13.dgn  
 wmd@rev

|                   |                      |
|-------------------|----------------------|
| TIP NO.<br>U-3306 | SHEET NO.<br>PMP-13a |
| APPROVED: _____   |                      |
| DATE: _____       |                      |
| SEAL              |                      |
|                   |                      |

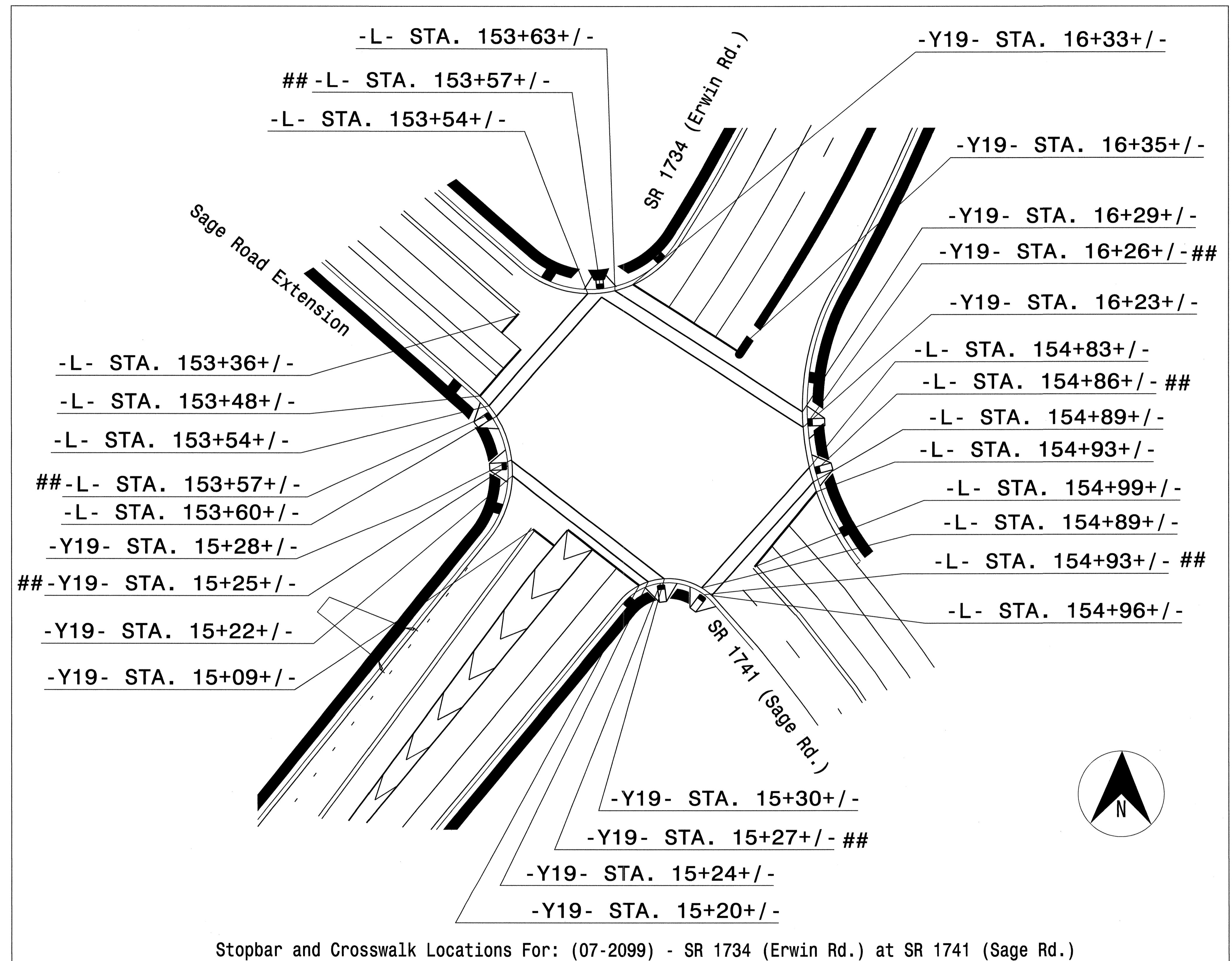

- L- STA. 153+63+/-
- ## -L- STA. 153+57+/-
- L- STA. 153+54+/-
- L- STA. 153+36+/-
- L- STA. 153+48+/-
- L- STA. 153+54+/-
- ## -L- STA. 153+57+/-
- L- STA. 153+60+/-
- Y19- STA. 15+28+/-
- ## -Y19- STA. 15+25+/-
- Y19- STA. 15+22+/-
- Y19- STA. 15+09+/-
- Y19- STA. 16+33+/-
- Y19- STA. 16+35+/-
- Y19- STA. 16+29+/-
- Y19- STA. 16+26+/- ##
- Y19- STA. 16+23+/-
- L- STA. 154+83+/-
- L- STA. 154+86+/- ##
- L- STA. 154+89+/-
- L- STA. 154+93+/-
- L- STA. 154+99+/-
- L- STA. 154+89+/-
- L- STA. 154+93+/- ##
- L- STA. 154+96+/-
- Y19- STA. 15+30+/-
- Y19- STA. 15+27+/- ##
- Y19- STA. 15+24+/-
- Y19- STA. 15+20+/-

## Center of Curb Ramp

STOP BAR, CROSSWALK and CURB RAMP LOCATIONS

PAVEMENT MARKING DETAIL

19-APR-2010 14:13  
 P:\TIP\Projects\07-2099\Traffic\Signing\CADD\PMU-U-3306.PMP.13a.dgn  
 wmcbr@w