

CONTRACT: C202472 T.I.P.: I-4407

**STATE OF NORTH CAROLINA
 DEPARTMENT OF TRANSPORTATION**

**PAVEMENT MARKING PLAN
 RANDOLPH COUNTY**

**LOCATION: US 220 (FUTURE I-73/74) FROM SOUTH OF
 NC 134 - US 220 BUSINESS TO NORTH
 OF SR 1462 (PARK DRIVE EXT.)**

TIP NO. I - 4407	SHEET NO. PMP - 1
APPROVED: _____	
DATE: _____	
SEAL	

ROADWAY STANDARD DRAWING

THE FOLLOWING ROADWAY STANDARDS AS APPEAR IN "ROADWAY STANDARD DRAWINGS" - PROJECT SERVICES UNIT - N.C. DEPARTMENT OF TRANSPORTATION - RALEIGH, N.C., DATED JULY 2006 ARE APPLICABLE TO THIS PROJECT AND BY REFERENCE HEREBY ARE CONSIDERED A PART OF THESE PLANS:

STD. NO.	TITLE
1205.01	PAVEMENT MARKINGS - LINE TYPES AND OFFSETS
1205.02	PAVEMENT MARKINGS - 2 LANE AND MULTILANE ROADWAYS
1205.03	PAVEMENT MARKINGS - INTERCHANGES
1205.06	PAVEMENT MARKINGS - THRU LANE DROPS
1205.08	PAVEMENT MARKINGS - SYMBOL AND WORD MESSAGES
1205.09	PAVEMENT MARKINGS - PAINTED ISLANDS
1205.12	PAVEMENT MARKINGS - BRIDGES
1250.01	PAVEMENT MARKER SPACING
1251.01	RAISED PAVEMENT MARKERS - TEMPORARY AND PERMANENT
1253.01	SNOWPLOWABLE RAISED PAVEMENT MARKERS
1261.01	GUARDRAIL AND BARRIER DELINEATOR SPACING
1261.02	GUARDRAIL AND BARRIER DELINEATOR TYPES
1262.01	GUARDRAIL END DELINEATION

PROJECT NOTES

- Review and record the existing pavement markings and markers prior to milling and resurfacing. Use the record of existing pavement markings and markers in accordance with the Roadway Standard Drawings to re-establish the proposed pavement markings and markers. The Contractor shall submit a pavement marking plan to the Engineer for approval 7 calendar days before any pavement markings are placed.

PLAN PREPARED BY: N.C.D.O.T. SIGNING AND DELINEATION UNIT

RON KING, P.E. STATE SIGNING & DELINEATION ENGINEER
SAMUEL D. COLEMAN SIGNING & DELINEATION PROJECT DESIGN ENGINEER

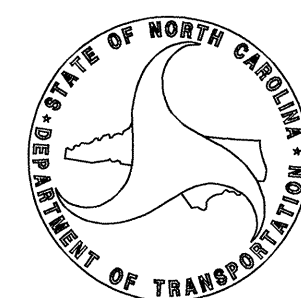

GENERAL NOTES

THE FOLLOWING GENERAL NOTES APPLY AT ALL TIMES FOR THE DURATION OF THE CONSTRUCTION PROJECT, EXCEPT WHEN OTHERWISE NOTED IN THE PLAN, OR DIRECTED BY THE ENGINEER.

- A) INSTALL PAVEMENT MARKINGS AND PAVEMENT MARKERS ON THE FINAL SURFACE AS FOLLOWS:

ROAD NAME	MARKING	MARKER
I 73/74 US 220	THERMOPLASTIC	SNOWPLOWABLE
BRIDGE	COLD APPLIED PLASTIC (TYPE III)	RAISED

- B) TIE PROPOSED PAVEMENT MARKING LINES TO EXISTING PAVEMENT MARKING LINES.
- C) REMOVE/REPLACE ANY CONFLICTING/DAMAGED PAVEMENT MARKINGS AND MARKERS.
- D) STOPBAR LOCATION AT NON-SIGNALIZED INTERSECTIONS MAY BE ADJUSTED AS DIRECTED BY THE ENGINEER.
- E) REMOVE ALL RESIDUE AND SURFACE LAITANCE BY ACCEPTABLE METHODS ON THE BRIDGE DECK(S) PRIOR TO PLACING (COLD APPLIED PLASTIC) PAVEMENT MARKING.

INDEX

SHEET NO.	DESCRIPTION
PMP-1	PAVEMENT MARKING PLAN TITLE SHEET
PMP-2	PAVEMENT MARKING SCHEDULE
PMP-3-12	PAVEMENT MARKING DETAIL

TIP NO.	SHEET NO.
I-4407	PMP-2
APPROVED: _____	
DATE: _____	
SEAL	

Pavement Marking Schedule

TIP Project # I-4407

SYMBOL DESCRIPTION

**FINAL
MARKERS**

PERMANENT RAISED PAVEMENT MARKERS
MB CRYSTAL & RED

SNOWPLOWABLE RAISED PAVEMENT MARKERS
MF CRYSTAL & RED

FINAL

PAVEMENT MARKINGS

THERMOPLASTIC(12", 90 MILS)
TY WHITE GORELINE

THERMOPLASTIC(6", 120 MILS)

TJ 10 FT. WHITE SKIP
TK 2 FT. - 13 FT./SP WHITE MINISKIP

THERMOPLASTIC(6", 90 MILS)

T6 WHITE EDGELINE
T7 YELLOW EDGELINE

COLD APPLIED PLASTIC (6") Type3 - Permanent Wet Reflective

C6 WHITE EDGELINE
C7 YELLOW EDGELINE
CK 10 FT. WHITE SKIP

THERMOPLASTICPAVEMENT MARKING SYMBOLS (90 MILS)

UC STRAIGHT ARROW

PAVEMENT MARKING SCHEDULE

I2-MAR-2010 11:48
 F:\TIP\Projects\I-4407\Traffic\Signing\CADD\PMMP\ Pavement Marking Seed.dgn
 80610001 - AT 100221660

TIP NO.	SHEET NO.
I-4407	PMP-3

APPROVED: _____
DATE: _____

SEAL

BEGIN STATE SIGNING PROJECT I-4407
STA 14+00

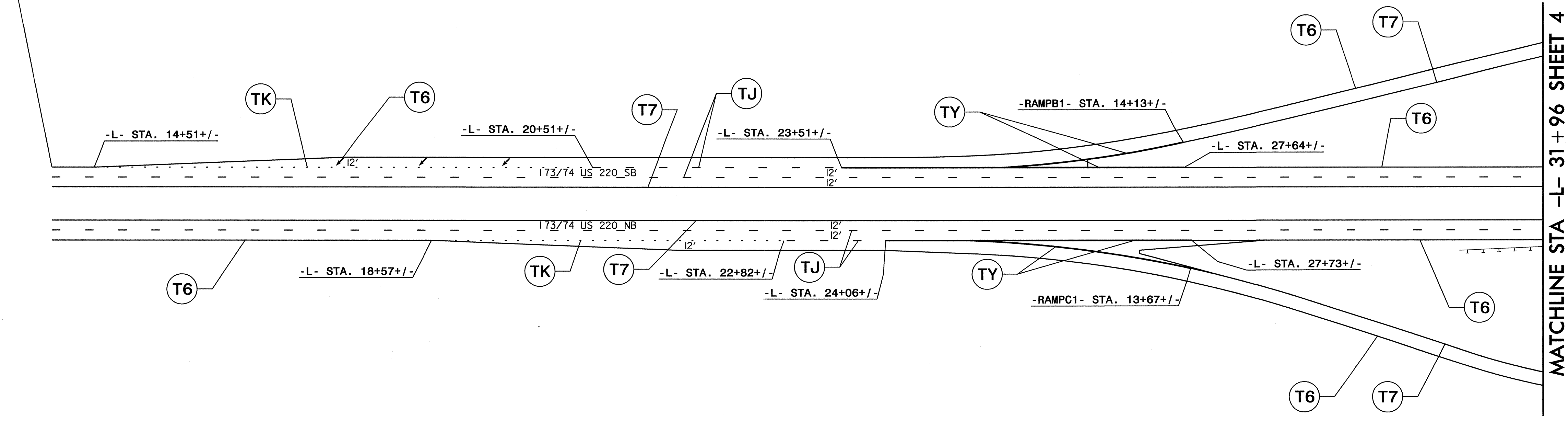

MATCHLINE STA -L- 31+96 SHEET 4

PROPOSED PAVEMENT MARKING
PLANS

I:\MAR-2010\1449\14407\14407_Signing\CADD\PMMP-I-4407_Sign_Sheet3.dgn
P:\Projects\14407\14407_Signing\CADD\PMMP-I-4407_Sign_Sheet3.dgn
scoleman

TIP NO. I-4407	SHEET NO. PMP-4
APPROVED: _____	
DATE: _____	
SEAL	

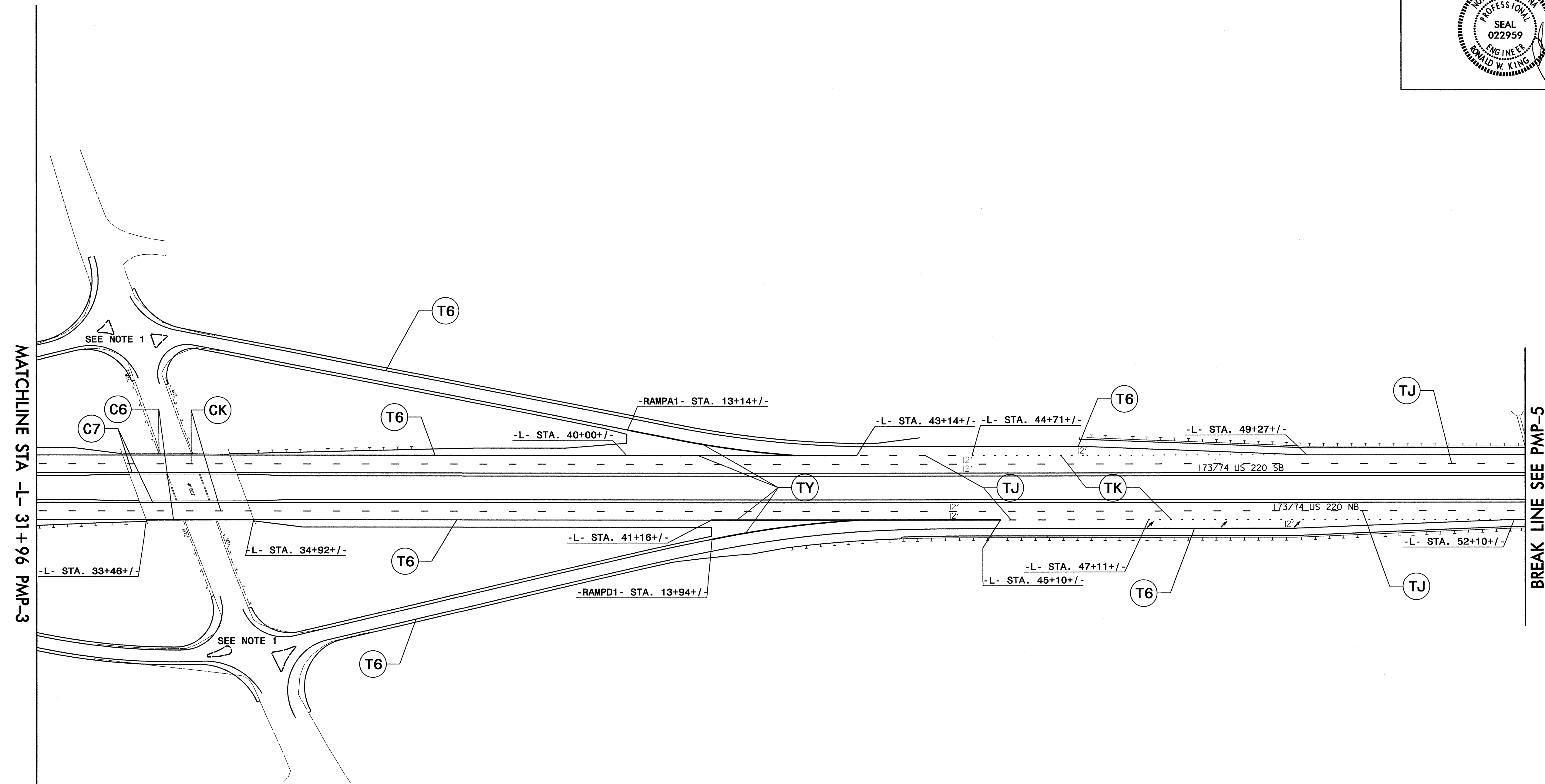

PROPOSED PAVEMENT MARKING
PLANS

I:\2-MAR-2010 11:50
 P:\Projects\I-4407\Ref\c\Signing\CADD\PMPI-4407_Sgn_PMP_sheet4.dgn
 scoleman AT TECC21660

TIP NO. I-4407	SHEET NO. PMP-5
APPROVED: _____	
DATE: _____	
SEAL	

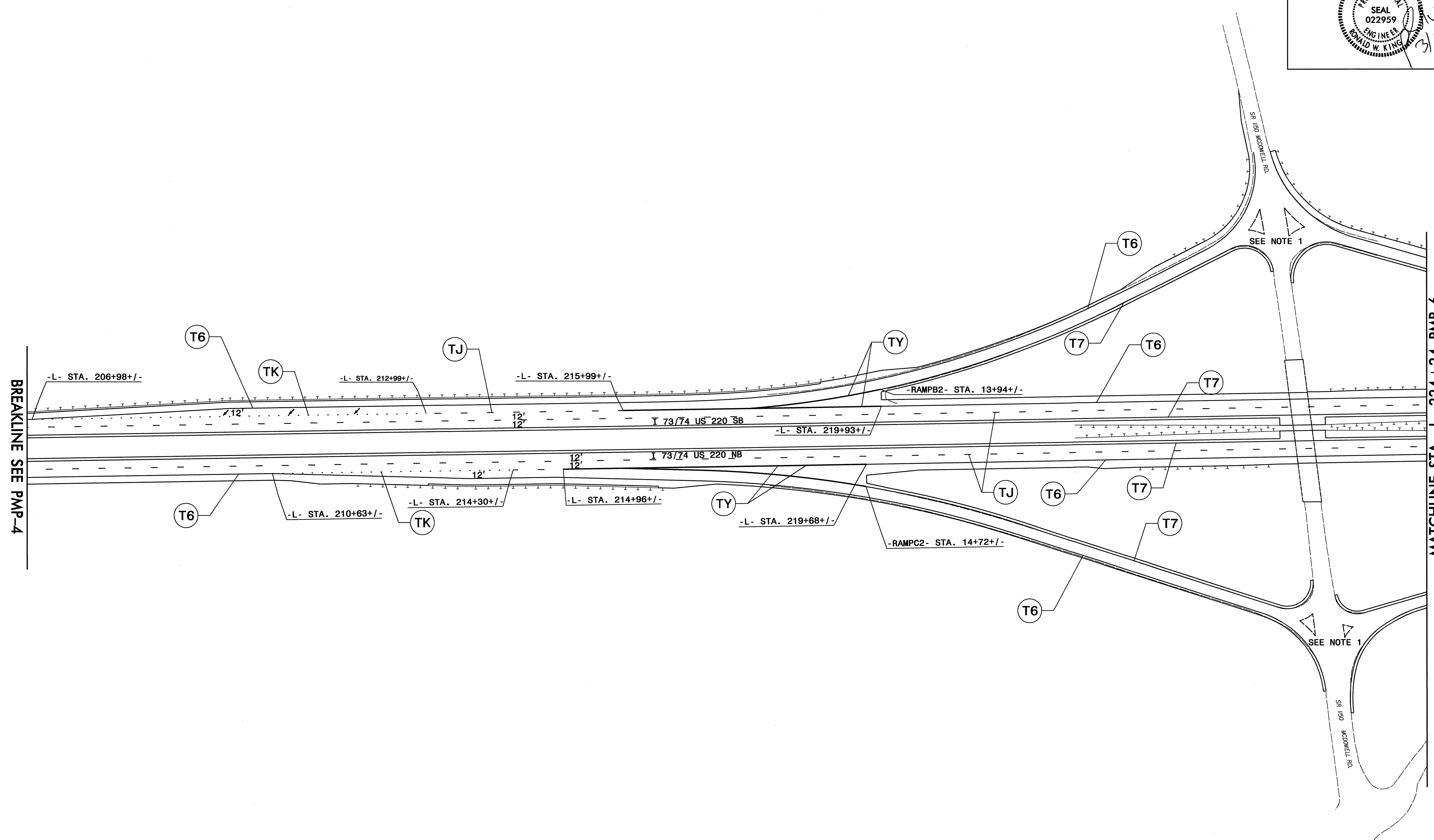

**PROPOSED PAVEMENT MARKING
PLANS**

I:\2-MAR-2010 11:51
 F:\Projects\I-4407\Signing\CADD\PMPI-4407_Sign_PMP_sheet5.dgn
 AT TECC221660
 scoleman

TIP NO.	SHEET NO.
I-4407	PMP-6
APPROVED: _____	
DATE: _____	
SEAL	

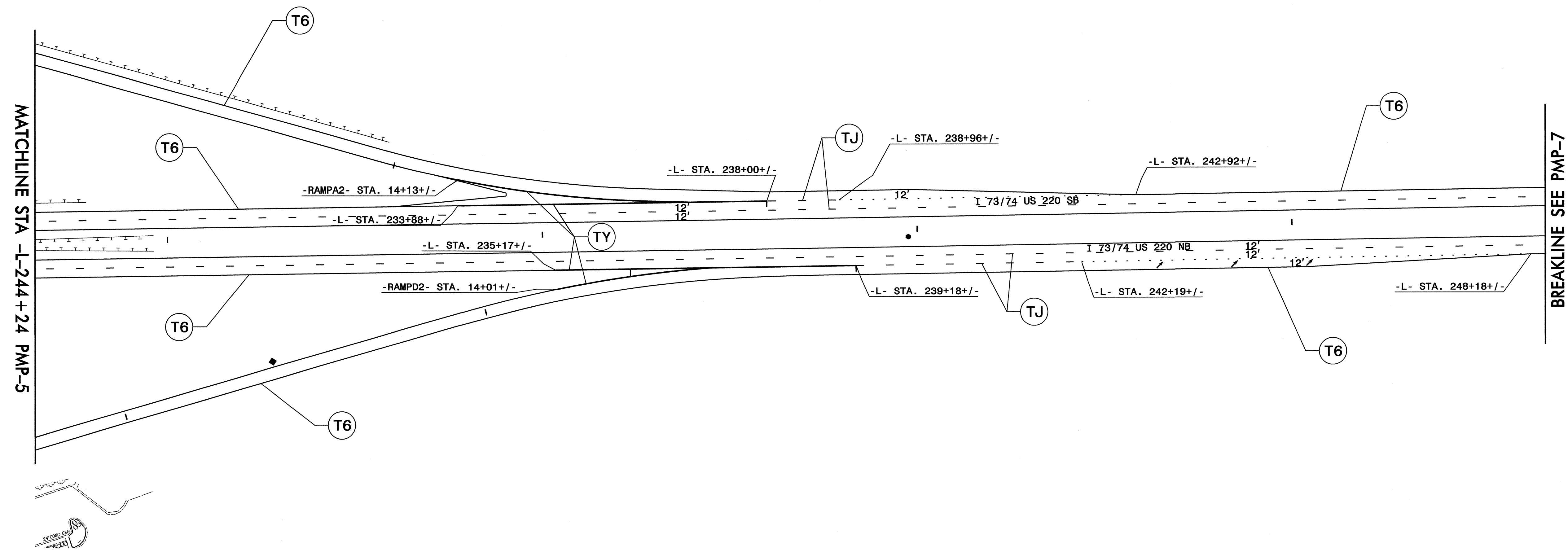
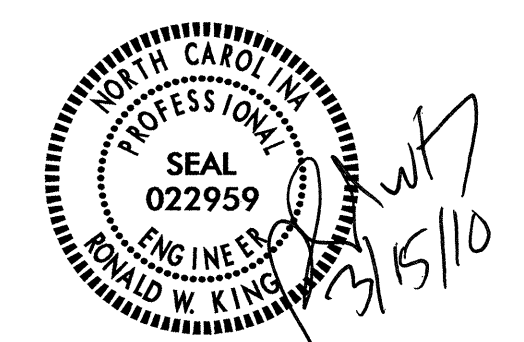

**PROPOSED PAVEMENT MARKING
PLANS**

I:\MIS\2010_IL\51\Projects\I-4407_Traffic\Signing\CADD\NMP\I-4407_Sgn_PMP_sheet6.dgn
 AT: scoleman

TIP NO. I-4407	SHEET NO. PMP-9
APPROVED: _____	
DATE: _____	
SEAL	

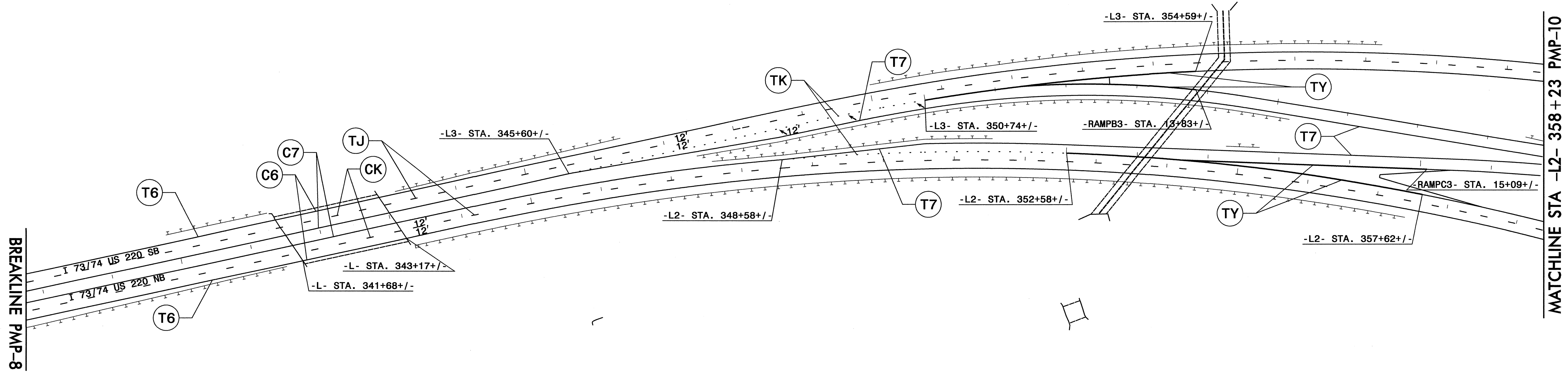
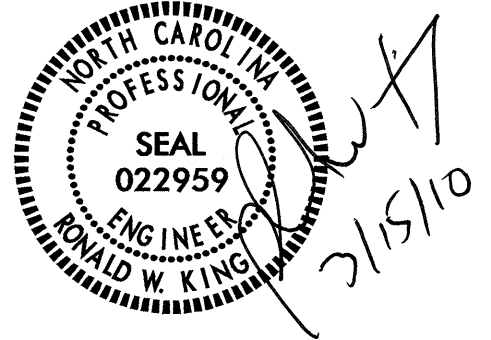

I:\MAPS\2010\2244
 P:\V\Projects\Projects\AT\TEC221660
 I:\MAPS\2010\2244\I-4407\Traffic\Signing\CADD\PMPI-4407_Sgn_PMP_sheet9.dgn
 scoleman

PROPOSED PAVEMENT MARKING
PLANS

TIP NO. I-4407	SHEET NO. PMP-10
APPROVED: _____	
DATE: _____	
SEAL	

MATCHLINE STA -L2- 358 + 23 PMP-9

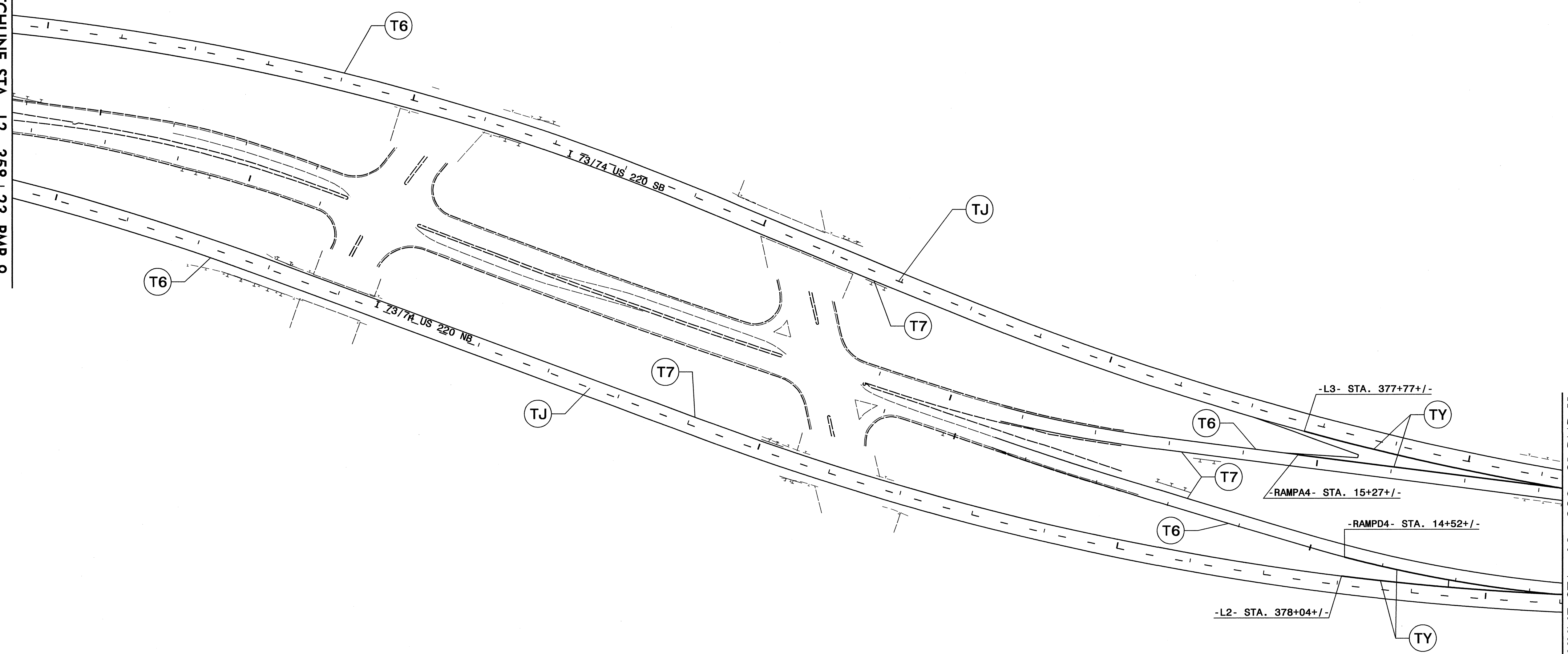

MATCHLINE STA -L2- 380 + 81 PMP-11

**PROPOSED PAVEMENT MARKING
PLANS**

I:\MPS\2010\1218
 P:\TIP\Projects\I-4407\Traffic\Signing\CADD\PMPI-4407_Sgn_PMP_sheet10.dgn
 AT: TECC22166
 scoleman

TIP NO. I-4407	SHEET NO. PMP-11
APPROVED: _____	
DATE: _____	
SEAL	

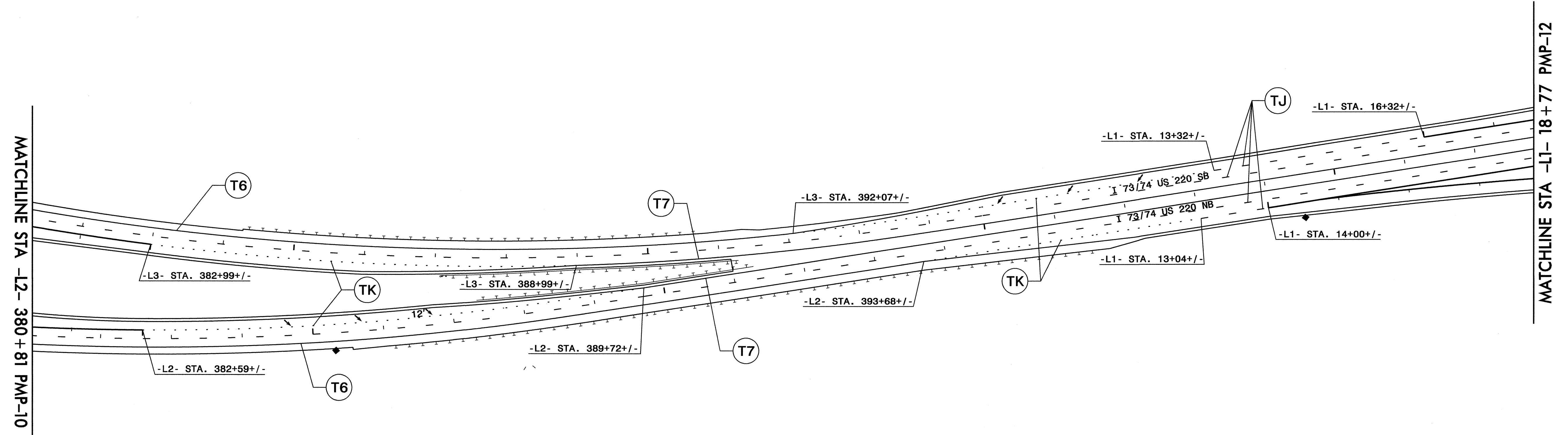
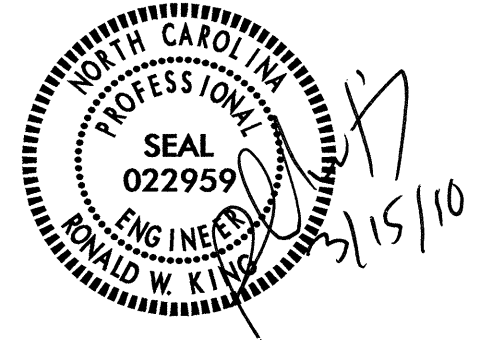

**PROPOSED PAVEMENT MARKING
PLANS**

I:\Projects\2010\1447\1-4407-Traffic\Signing\CADD\PMPI-4407-Sgn-PMP-sheet1.dgn
 2/15/10
 scolemm

TIP NO. I-4407	SHEET NO. PMP-12
APPROVED: _____	
DATE: _____	
SEAL	

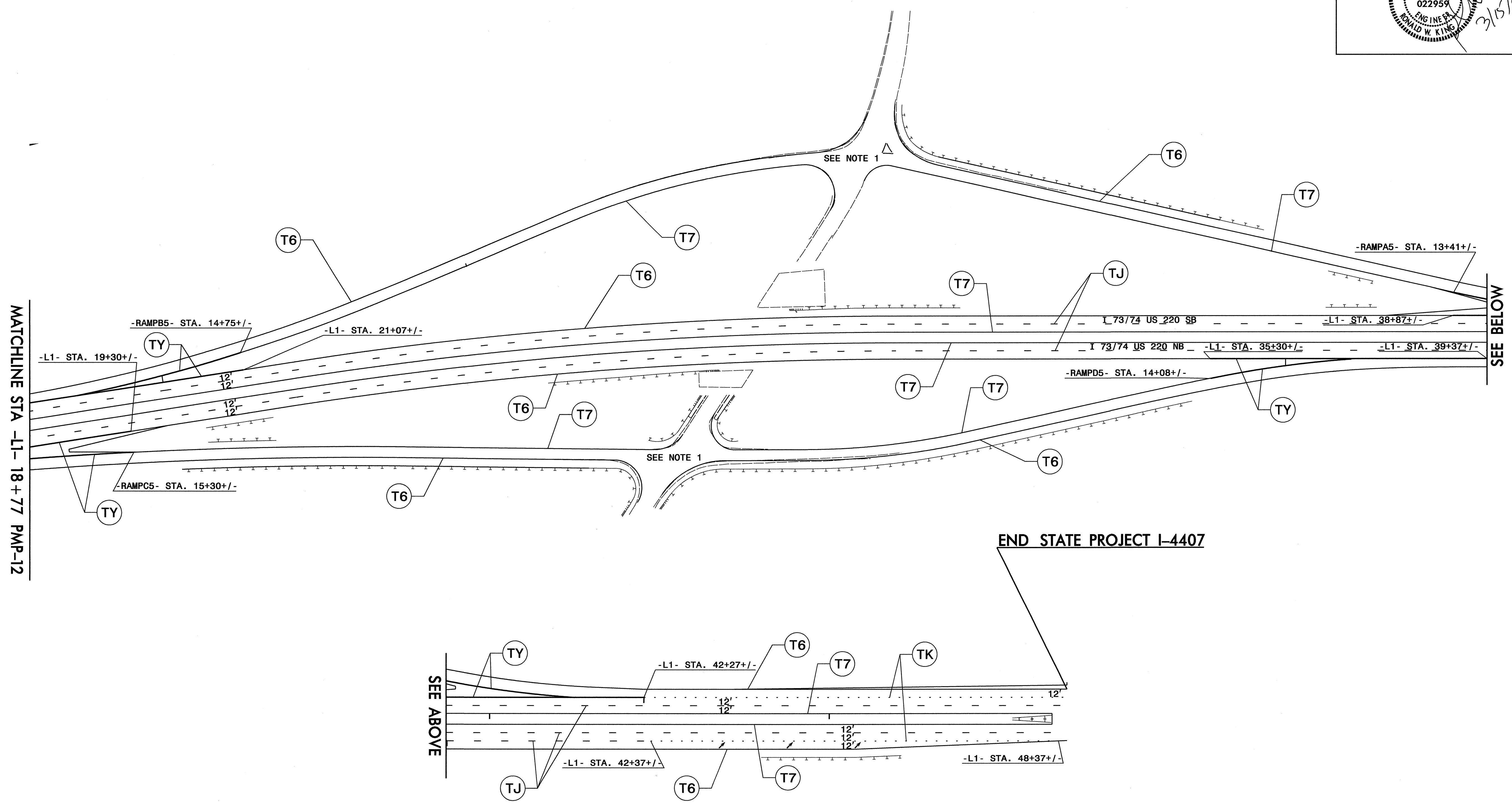

**PROPOSED PAVEMENT MARKING
PLANS**

I:\Projects\I-4407\Traffic\Signing\CADD\PMPI-4407_Sgn_PMP_sheet12.dgn
 15-MAR-2010 14:44
 J:\Projects\I-4407\Traffic\Signing\CADD\PMPI-4407_Sgn_PMP_sheet12.dgn
 scoleman