

STATE OF NORTH CAROLINA  
DIVISION OF HIGHWAYS



STATE PROJECT REFERENCE NO.	SHEET NO.
R-2824	TCP-01

**PLAN FOR PROPOSED  
TRAFFIC CONTROL, MARKING & DELINEATION  
BURKE COUNTY**

R-2824

**ROADWAY STANDARD DRAWINGS**

THE FOLLOWING ROADWAY STANDARDS AS APPEAR IN "METRIC ROADWAY STANDARD DRAWINGS"-  
PROJECT SERVICES UNIT-N.C. DEPARTMENT OF TRANSPORTATION-RALEIGH, N.C.,  
DATED JULY 2006 ARE APPLICABLE TO THIS PROJECT AND BY REFERENCE HEREBY ARE  
CONSIDERED A PART OF THESE PLANS:

STD. NO.	TITLE
1101.02	TEMPORARY LANE CLOSURES
1101.03	TEMPORARY ROAD CLOSURES
1101.05	WORK ZONE VEHICLE ACCESSES
1110.01	STATIONARY WORK ZONE SIGNS
1110.02	PORTABLE WORK ZONE SIGNS
1130.01	DRUMS
1135.01	CONES
1145.01	BARRICADES
1150.01	FLAGGERS
1205.01	PAVEMENT MARKINGS - LINE TYPES & OFFSETS
1205.02	PAVEMENT MARKINGS - 2 LANE & MULTILANE ROADWAYS
1205.04	PAVEMENT MARKINGS - INTERSECTIONS
1205.05	PAVEMENT MARKINGS - TURN LANES
1205.06	PAVEMENT MARKINGS - THRU LANE DROPS
1205.08	PAVEMENT MARKINGS - SYMBOLS & WORD MESSAGES
1205.09	PAVEMENT MARKINGS - PAINTED ISLANDS
1205.12	PAVEMENT MARKINGS - BRIDGES
1250.01	PAVEMENT MARKER SPACING
1251.01	RAISED PAVEMENT MARKERS (TEMPORARY & PERMANENT)
1253.01	SNOWPLOWABLE RAISED PAVEMENT MARKERS
1261.01	GUARDRAIL & BARRIER DELINEATOR SPACING
1261.02	GUARDRAIL & BARRIER DELINEATOR TYPES
1262.01	GUARDRAIL END DELINEATION

**INDEX OF SHEETS**

SHEET NO.	TITLE
TCP-01	LIST OF APPLICABLE ROADWAY STANDARD DRAWINGS, LEGEND AND INDEX OF SHEETS
TCP-02-02A	GENERAL NOTES AND TEMPORARY PAVEMENT MARKING SCHEDULE
TCP-03	PHASING
TCP-04 THRU TCP-10	PHASE I
TCP-11 THRU TCP-13	PHASE II
TCP-14	PHASE III
TCP-15 AND TCP-16	DETOUR ROUTE AND SIGNING
TCP-17	ADVANCE WORK ZONE WARNING SIGNS
SD-1 AND SD-2	SIGN DESIGN

**LEGEND**

- GENERAL**
- DIRECTION OF TRAFFIC FLOW
  - NORTH ARROW
  - PROPOSED PVMT. EXIST. PVMT.
  - WORK AREA
  - REMOVAL OF EXISTING PAVEMENT
- TRAFFIC CONTROL DEVICES**
- TYPE I BARRICADE
  - TYPE II BARRICADE
  - TYPE III BARRICADE
  - CONE
  - DRUM SKINNY DRUM
  - FLASHING ARROW PANEL (TYPE C)
  - STATIONARY SIGN
  - PORTABLE SIGN
  - STATIONARY OR PORTABLE SIGN
  - CRASH CUSHION
  - CHANGEABLE MESSAGE SIGN
  - TRUCK MOUNTED IMPACT ATTENUATOR (TMIA)
  - POLICE
  - FLAGGER
- PAVEMENT MARKINGS**
- CRYSTAL/CRYSTAL PAVEMENT MARKER
  - YELLOW/YELLOW PAVEMENT MARKER
  - CRYSTAL/RED PAVEMENT MARKER
  - PAVEMENT MARKING SYMBOLS

02-MAR-2010 15:45  
\\dot\dfs\0010\NSProj\TIP\Projects-R\2824\TrafficControl\tcp\2824\_tcp01\_title.shdgn  
akp\atl AT WZTC244748

TIP PROJECT:

APPROVED:	PLAN PREPARED BY: N.C.D.O.T. TRAFFIC CONTROL, MARKING & DELINEATION SECTION
DATE: March 3, 2010	STUART BOURNE, P.E. TRAFFIC CONTROL ENGINEER
SEAL	J. STEVE KITE, P.E. TRAFFIC CONTROL PROJECT ENGINEER
	DON PARKER TRAFFIC CONTROL PROJECT DESIGN ENGINEER
	ASHVIN PATEL, P.E. TRAFFIC CONTROL DESIGN ENGINEER / TECHNICIAN



PROJ. REFERENCE NO.	SHEET NO.
R-2824	TCP-02
BURKE	

# GENERAL NOTES

CHANGES MAY BE REQUIRED WHEN PHYSICAL DIMENSIONS IN THE DETAIL DRAWINGS, STANDARD DETAILS AND ROADWAY DETAILS ARE NOT ATTAINABLE TO MEET FIELD CONDITIONS, OR RESULT IN DUPLICATE, OR UNDESIRE OVERLAPPING OF DEVICES. MODIFICATION MAY INCLUDE: MOVING, SUPPLEMENTING, COVERING OR REMOVAL OF DEVICES, AS DIRECTED BY THE ENGINEER.

THE FOLLOWING GENERAL NOTES APPLY AT ALL TIMES FOR THE DURATION OF THE CONSTRUCTION PROJECT, EXCEPT WHEN OTHERWISE NOTED IN THE PLAN, OR DIRECTED BY THE ENGINEER.

**A) DO NOT CLOSE ROADS AS FOLLOWS:**

ROAD NAME	DAY AND TIME RESTRICTIONS
MALCOLM BOULEVARD (-Y12-)	7-9 A.M., 4-6 P.M. MON.-FRI.

**LANE AND SHOULDER CLOSURE REQUIREMENTS**

- B) REMOVE LANE CLOSURE DEVICES FROM THE LANE WHEN WORK IS NOT BEING PERFORMED BEHIND THE LANE CLOSURE OR WHEN A LANE CLOSURE IS NO LONGER NEEDED, OR AS DIRECTED BY THE ENGINEER.
- C) WHEN PERSONNEL AND/OR EQUIPMENT ARE WORKING WITHIN 5 M OF AN AN OPEN TRAVEL LANE, CLOSE THE NEAREST OPEN SHOULDER USING ROADWAY STANDARD DRAWING NO. 1101.04 UNLESS THE WORK AREA IS PROTECTED BY BARRIER OR GUARDRAIL OR A LANE CLOSURE IS INSTALLED.
- D) WHEN PERSONNEL AND/OR EQUIPMENT ARE WORKING ON THE SHOULDER ADJACENT TO AN UNDIVIDED FACILITY AND WITHIN 1.5 M OF AN OPEN TRAVEL LANE, CLOSE THE NEAREST OPEN TRAVEL LANE USING ROADWAY STANDARD DRAWING NO. 1101.02 UNLESS THE WORK AREA IS PROTECTED BY BARRIER OR GUARDRAIL.

WHEN PERSONNEL AND/OR EQUIPMENT ARE WORKING ON THE SHOULDER ADJACENT TO A DIVIDED FACILITY AND WITHIN 3 M OF AN OPEN TRAVEL LANE, CLOSE THE NEAREST OPEN TRAVEL LANE USING ROADWAY STANDARD DRAWING NO. 1101.02 UNLESS THE WORK AREA IS PROTECTED BY BARRIER OR GUARDRAIL.

- E) WHEN PERSONNEL AND/OR EQUIPMENT ARE WORKING WITHIN A LANE OF TRAVEL OF AN UNDIVIDED OR DIVIDED FACILITY, CLOSE THE LANE ACCORDING TO THE TRAFFIC CONTROL PLANS, ROADWAY STANDARD DRAWINGS OR AS DIRECTED BY THE ENGINEER. CONDUCT THE WORK SO THAT ALL PERSONNEL AND/OR EQUIPMENT REMAIN WITHIN THE CLOSED TRAVEL LANE.

- F) DO NOT INSTALL MORE THAN 1 Km OF LANE CLOSURE ON LOVELADY ROAD MEASURED FROM THE BEGINNING OF THE MERGE TAPER TO THE END OF THE LANE CLOSURE.

- G) DO NOT INSTALL MORE THAN ONE LANE CLOSURE, IN ANY ONE DIRECTION, ON LOVELADY ROAD.

**PAVEMENT EDGE DROP OFF REQUIREMENTS**

- H) BACKFILL AT A 6:1 SLOPE UP TO THE EDGE AND ELEVATION OF EXISTING PAVEMENT IN AREAS ADJACENT TO AN OPENED TRAVEL LANE THAT HAS AN EDGE OF PAVEMENT DROP-OFF AS FOLLOWS:

BACKFILL DROP-OFFS THAT EXCEED 50 MM ON ROADWAYS WITH POSTED SPEED LIMITS OF 45 MPH OR GREATER.

BACKFILL DROP-OFFS THAT EXCEED 75 MM ON ROADWAYS WITH POSTED SPEED LIMITS LESS THAN 45 MPH.

BACKFILL WITH SUITABLE COMPACTED MATERIAL, AS APPROVED BY THE ENGINEER, AT NO EXPENSE TO THE DEPARTMENT.

- I) DO NOT EXCEED A DIFFERENCE OF 50 MM IN ELEVATION BETWEEN OPEN LANES OF TRAFFIC FOR NOMINAL LIFTS OF 40 MM. INSTALL ADVANCE WARNING "UNEVEN LANES" SIGNS (W8-11) 1 Km IN ADVANCE AND A MINIMUM OF EVERY ONE KILOMETER THROUGHOUT THE UNEVEN AREA.

**TRAFFIC PATTERN ALTERATIONS**



- J) NOTIFY THE ENGINEER TWENTY ONE (21) CALENDAR DAYS PRIOR TO ANY TRAFFIC PATTERN ALTERATION.

**SIGNING**

- K) INSTALL ADVANCE WORK ZONE WARNING SIGNS WHEN WORK IS WITHIN 12 M FROM THE EDGE OF TRAVEL LANE AND NO MORE THAN THREE (3) DAYS PRIOR TO THE BEGINNING OF CONSTRUCTION.
- L) PROVIDE PERMANENT SIGNING.
- M) PROVIDE DETOUR SIGNING WITHIN AND OFF THE PROJECT LIMITS.
- N) COVER OR REMOVE ALL DETOUR SIGNS WITHIN AND OFF THE PROJECT LIMITS WHEN A DETOUR IS NOT IN OPERATION.
- O) ENSURE ALL NECESSARY SIGNING IS IN PLACE PRIOR TO ALTERING ANY TRAFFIC PATTERN.
- P) INSTALL BLACK ON ORANGE "DIP" SIGNS (W8-2) AND/OR "BUMP" SIGNS (W8-1) 150m IN ADVANCE OF THE UNEVEN AREA, OR AS DIRECTED BY THE ENGINEER.

(CONTINUE ON TCP-02A)

02-MAR-2010 15:39 \\dot\dfsroot\01\NSP\01\TIP\Projects-R\R2824\Traffic\TrafficControl\tcp\2824\_tcp02\_gen\_notes.dgn ok\patel AT WZTC244748

APPROVED:  DATE: 3/3/10 	<h2 style="margin: 0;">GENERAL NOTES</h2>	<table border="1" style="width: 100%; border-collapse: collapse;"> <tr> <td style="font-size: small;">SCALE:</td> <td>NONE</td> </tr> <tr> <td style="font-size: small;">DATE:</td> <td>9/04</td> </tr> <tr> <td style="font-size: small;">DWG. BY:</td> <td>SJS</td> </tr> <tr> <td style="font-size: small;">DESIGN BY:</td> <td>SJS</td> </tr> <tr> <td style="font-size: small;">REVIEWED BY:</td> <td>CLM</td> </tr> </table>	SCALE:	NONE	DATE:	9/04	DWG. BY:	SJS	DESIGN BY:	SJS	REVIEWED BY:	CLM
SCALE:	NONE											
DATE:	9/04											
DWG. BY:	SJS											
DESIGN BY:	SJS											
REVIEWED BY:	CLM											
		<table border="1" style="width: 100%; border-collapse: collapse;"> <tr> <td style="text-align: center;">REVISIONS</td> </tr> <tr> <td style="height: 20px;"> </td> </tr> <tr> <td style="height: 20px;"> </td> </tr> <tr> <td style="height: 20px;"> </td> </tr> </table>	REVISIONS									
REVISIONS												



# PHASING



PROJ. REFERENCE NO.	SHEET NO.
R-2824	TCP-03
BURKE	

## PHASE I

- STEP 1 -- INSTALL WORK ZONE WARNING SIGNS ON -L- AND ALL -Y- LINES (SEE TCP-17).
- STEP 2 -- CONSTRUCT -DETOUR- STRUCTURE AND ALIGNMENT FROM STA. 10+00 +/- TO STA. 14+54 +/- (MAINTAIN ACCESS TO -Y6- PRIVATE DRIVE AT ALL TIMES) (SEE TCP-07).
- USING RSD 1101.02, SHEET 1 OF 9, BEGIN GRADING, DRAINAGE, AND WEDGING/PAVING OF -L-, -Y- LINES, AND TEMPORARY -DETOUR- UP TO, BUT NOT INCLUDING THE FINAL LAYER OF SURFACE COURSE AS SHOWN ON TCP-04 THRU TCP-10.
- USING RSD 1101.03, SHEET 2 OF 9, CLOSE -Y3- (FLORA LANE) AND PLACE TRAFFIC ON OFF-SITE DETOUR AS SHOWN ON TCP-15.
- CONSTRUCT -Y3- FROM 10+00 +/- TO 10+88 +/-
- REOPEN -Y3- TO TRAFFIC AS SHOWN ON TCP-05, "INSET J".

- B. PLACE TEMPORARY PAINT PAVEMENT MARKINGS AND MARKERS IN THE TEMPORARY TRAFFIC PATTERN DETAILED ON SHEET TCP-12 FROM -L- STA. 24+00 +/- TO STA. 30+00 +/-.
- C. RE-OPEN -L- TO TRAFFIC

- STEP 4 -- USING RSD 1101.02, SHEET 1 OF 9, PLACE PAVEMENT MARKINGS AND MARKERS AND SHIFT -Y12- (MALCOLM BLVD.) AND -Y12A- (CARNEGIE ST.) TO THE TEMPORARY PATTERN AS SHOWN ON TCP-13.
- CONSTRUCT PROPOSED -Y12- (MALCOLM BLVD.) LEFT SIDE CURB AND GUTTER, AND SIDEWALK AS SHOWN ON TCP-13.
- OBLITERATE CARNEGIE STREET AS SHOWN ON SHEET TCP-13.

## PHASE II

- STEP 1 -- USING RSD 1101.02, SHEET 1 OF 9, PLACE PAVEMENT MARKINGS AND MARKERS AND SHIFT -L- (LOVELADY ROAD) TRAFFIC TO THE TEMPORARY -DETOUR- AND STRUCTURE IN A TWO-LANE, TWO-WAY PATTERN AS SHOWN ON TCP-11. MAINTAIN ACCESS TO -Y6- PRIVATE DRIVE AT ALL TIMES.
- BEGIN CONSTRUCTION OF PROPOSED BRIDGE. CONSTRUCT -L- (LOVELADY ROAD) FROM STA. 19+47 +/- TO STA. 24+00 +/- (SEE TCP-11).
- STEP 2 -- COMPLETE THE GRADING/PAVING, AND CURB AND GUTTER, UP TO BUT NOT INCLUDING FINAL LAYER AS BEGUN IN PHASE I, STEP 2 IN THE FOLLOWING LOCATIONS:
- L- STA. 24+00 +/- TO 27+40 +/- RT.
  - L- STA. 26+90 +/- TO 29+60 +/- LT.
  - Y8- STA. 10+00 TO 10+47 +/- RT./LT.
  - Y9- STA. 10+40 TO 11+21 +/- RT./LT.
  - Y6- STA. 11+31 TO 11+53 +/- RT./LT.
  - Y7- STA. 10+00 TO 10+50 +/- RT./LT.

COMPLETE THE WORK OF PHASE II, STEP 3 IN ACCORDANCE WITH INTERMEDIATE CONTRACT TIME. (SEE INTERMEDIATE CONTRACT TIME AND LIQUIDATED DAMAGES).

- STEP 3 -- CLOSE AND DETOUR -L- AS PER TCP-16

- A. CONSTRUCT THE PROPOSED ROUNDABOUT AND APPROACHES UP TO BUT NOT INCLUDING THE FINAL LAYER OF SURFACE COURSE FROM -L- STA. 26+00 +/- TO STA. 28+00 +/- (SEE TCP-12).

## PHASE III

- STEP 1 -- COMPLETE PROPOSED BRIDGE AND LOVELADY RD FROM STA. -L- 19+47 TO 24+00 AS BEGUN IN PHASE II, STEP 1.

- STEP 2 -- INSTALL PERMANENT SIGNAL AT THE INTERSECTION OF -L- (LOVELADY ROAD) AND -Y12- (MALCOLM BLVD) AND COVER SIGNAL HEADS.

- USING RSD 1101.02, SHEET 1 OF 9, PLACE TEMP. PAVEMENT MARKINGS (PAINT) AND TEMPORARY MARKERS FROM STA. -L- 19+56 TO 25+00 AS SHOWN ON TCP-14.

- USING RSD 1101.02, SHEET 1 OF 9, PLACE TEMP. PAVEMENT MARKINGS (PAINT) AND TEMPORARY MARKERS AS MUCH AS POSSIBLE ON LOVELADY RD THROUGHOUT THE PROJECT AS SHOWN ON PAVEMENT MARKING PLANS AND SHIFT TRAFFIC AS PER FINAL TRAFFIC PATTERN.

- ACTIVATE THE PERMANENT SIGNAL AT THE INTERSECTION OF -L- AND -Y12-. (SEE SIGNAL PLANS)

- STEP 3 -- OBLITERATE TEMPORARY DETOUR AND STRUCTURE AS SHOWN ON TCP-14.

- USING RSD 1101.02, SHEET 1 OF 9, REMOVE -L- (LOVELADY ROAD) EXISTING PAVEMENT AREAS AS FOLLOWS AND COMPLETE PROPOSED SHOULDER CONSTRUCTION AND GUARDRAIL INSTALLATIONS (SEE TCP-12 AND TCP-14):

- L- LT. SIDE STA. 23+05 TO STA. 26+83 +/-
- L- RT. SIDE STA. 27+35 +/- TO STA. 29+37 +/-

- COMPLETE -Y6- PRIVATE DRIVE CONSTRUCTION AS SHOWN ON TCP-17

- STEP 4 -- USING RSD 1101.02, SHEET 1 OF 9, PLACE FINAL LAYER OF SURFACE COURSE, PROPOSED PAVEMENT MARKINGS AND MARKERS. REMOVE ALL TRAFFIC CONTROL DEVICES AND OPEN ROAD TO FINAL TRAFFIC PATTERN (SEE PAVEMENT MARKING PLANS).

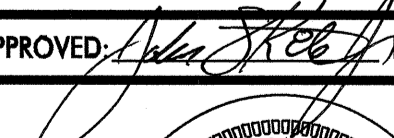
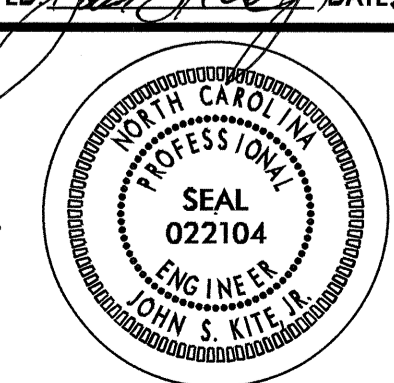
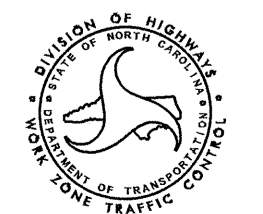
APPROVED:  DATE: 3/3/10		<h1>PHASING</h1>				
SEAL 	SCALE: NONE					
	DATE: 01/10	REVISIONS				
	DESIGN BY: AKP					
	REVIEWED BY: DAP					

02-MAR-2010 16:02 \\dot\dfs\101\MSR\proj\TIP\Projects-R\2824\Traffic\TrafficControl\tcp\2824\_tcp03\_phasing.dgn



PROJ. REFERENCE NO.	SHEET NO.
R-2824	TCP-04
BURKE	

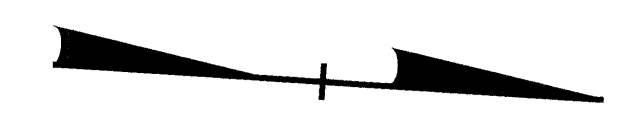
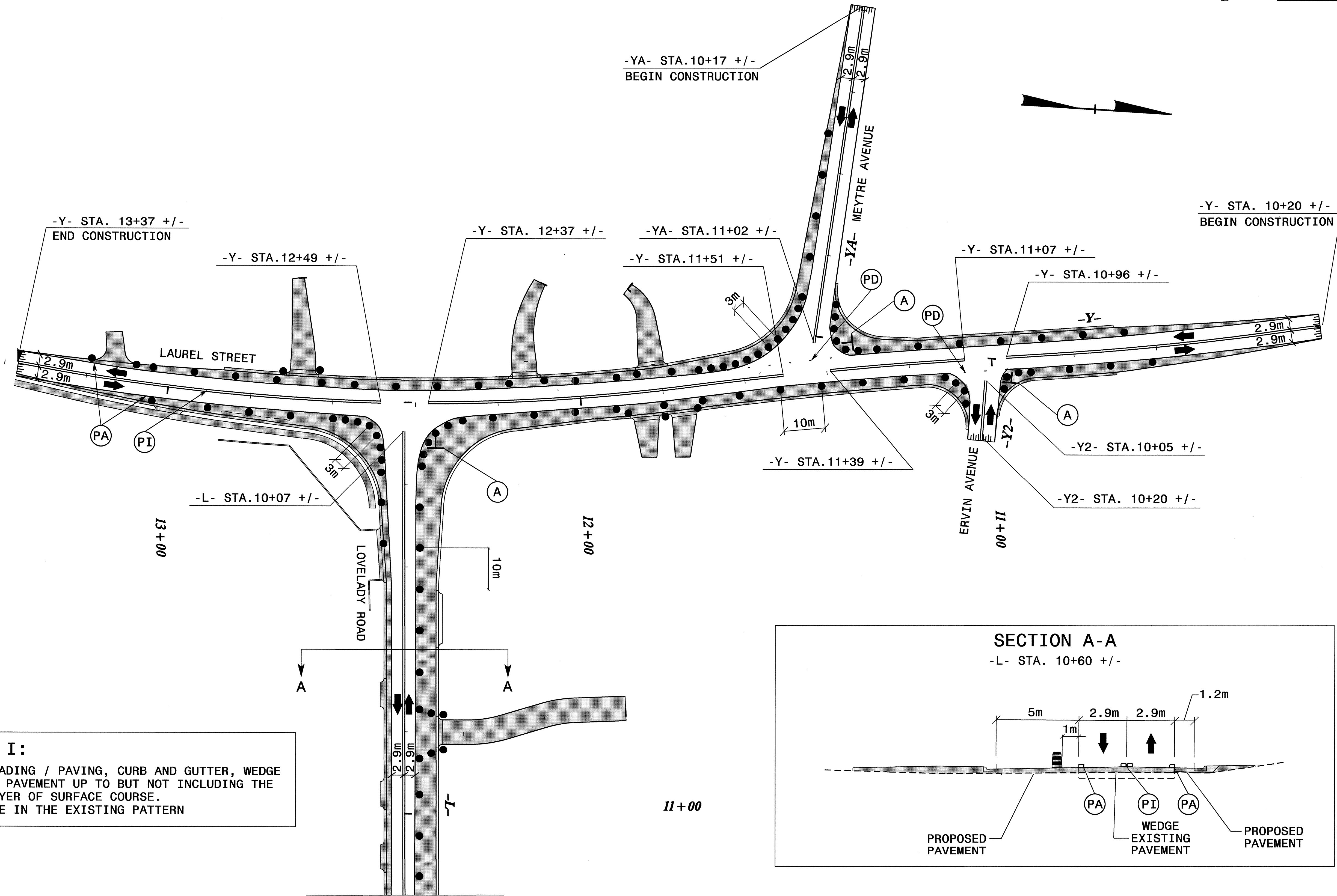

**PHASE I:**  
 BEGIN GRADING / PAVING, CURB AND GUTTER, WEDGE EXISTING PAVEMENT UP TO BUT NOT INCLUDING THE FINAL LAYER OF SURFACE COURSE.  
 RE-STRIPE IN THE EXISTING PATTERN

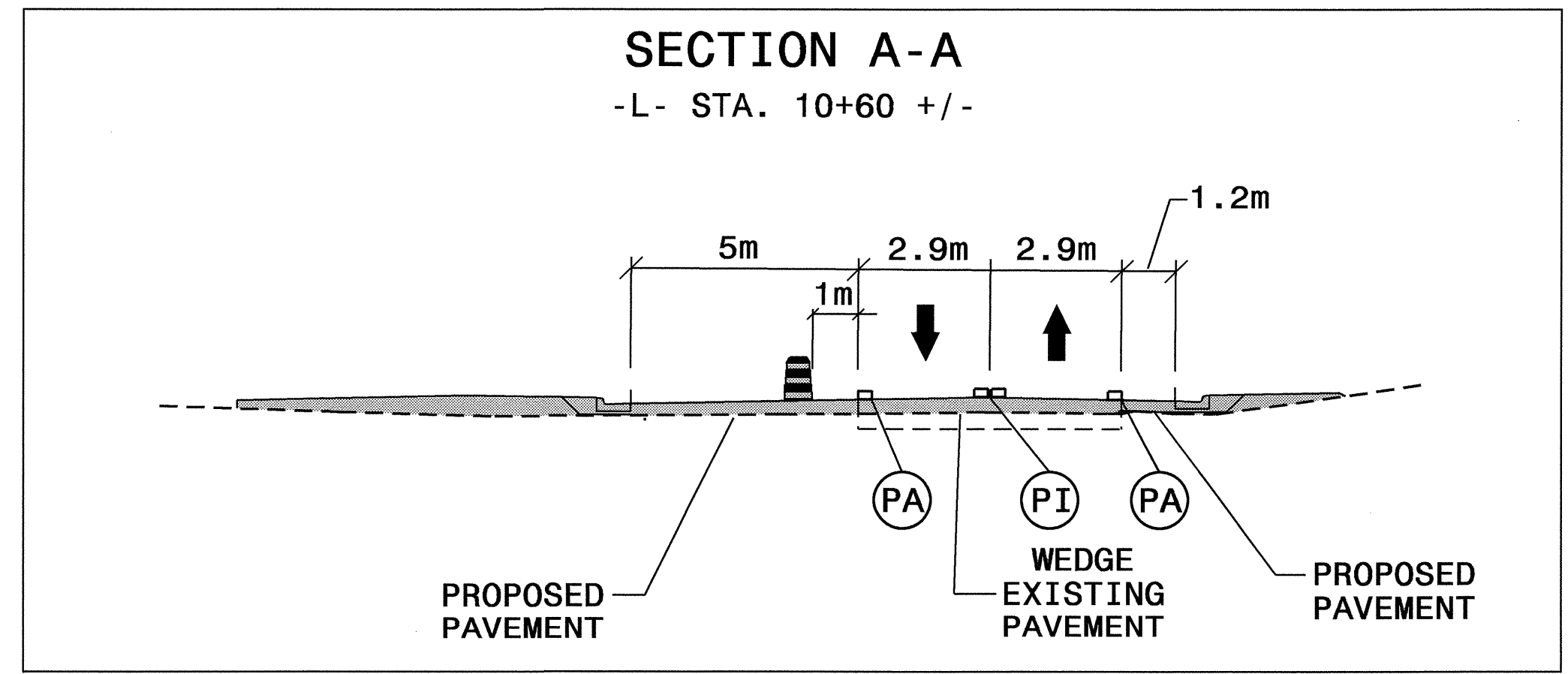

MATCHLINE  
 STA. 11+20 +/- -L-  
 SEE TCP-05

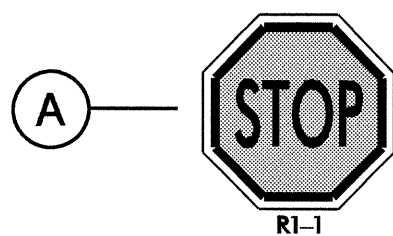

STOP SIGN LOCATIONS  
 TO BE VERIFIED BY THE  
 ENGINEER

APPROVED: *[Signature]* DATE: 3/3/10

SEAL

<b>PHASE I</b>		REVISIONS	
SCALE:	NONE		
DATE:	10/03		
DWG. BY:	SJS		
DESIGN BY:	SJS		
REVIEWED BY:	CLM		

02-MAR-2010 15:49  
 \\dot\dfsroot\NSP\proj\TIP\Projects-R\R2824\Traffic\TrafficControl\tcp\2824\_tcp04\_phase1.dgn  
 akdot\el AT WZTC24748



PROJ. REFERENCE NO.	SHEET NO.
R-2824	TCP-05
BURKE	

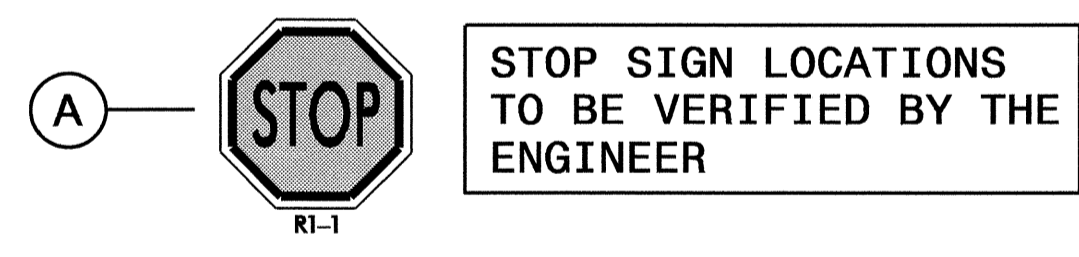
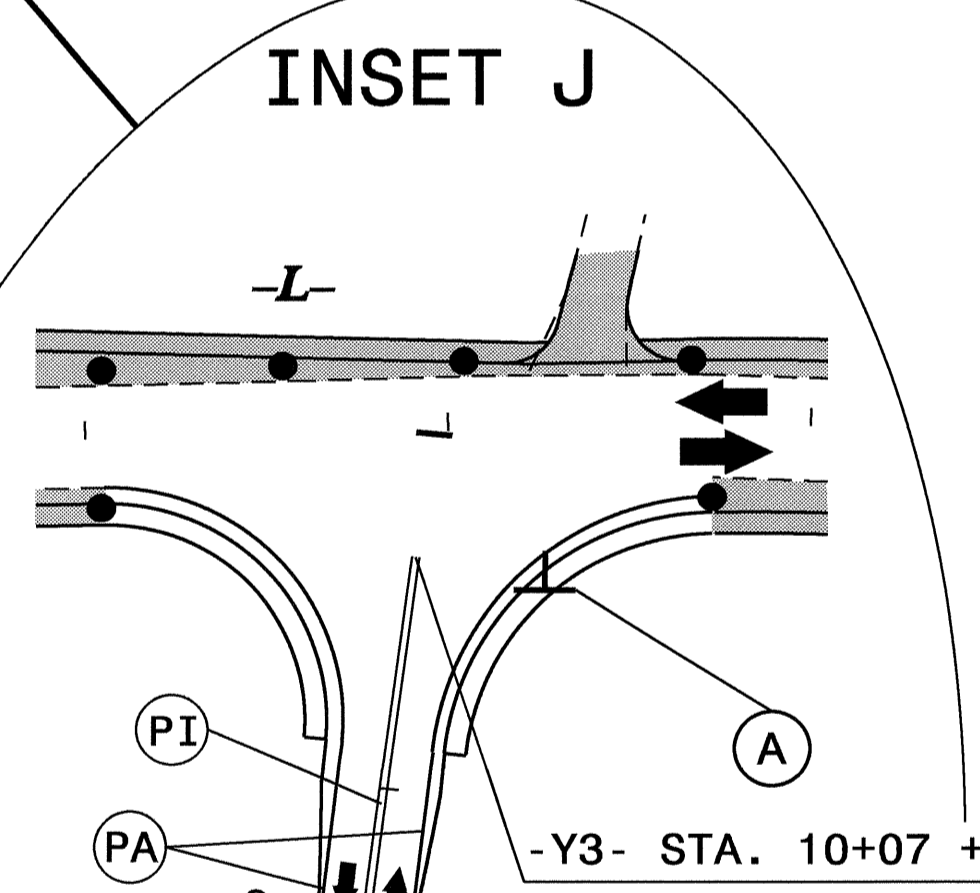
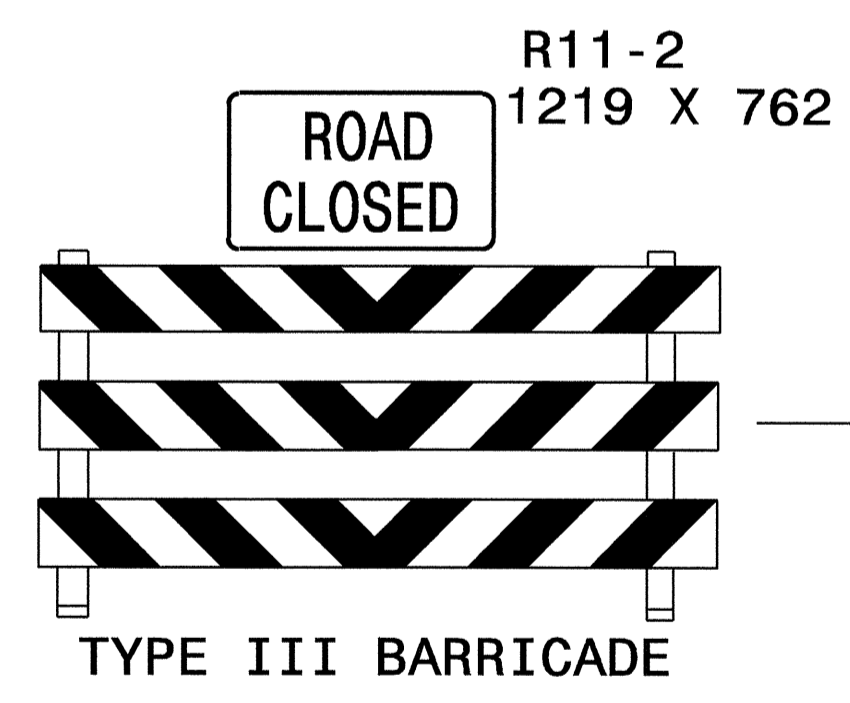
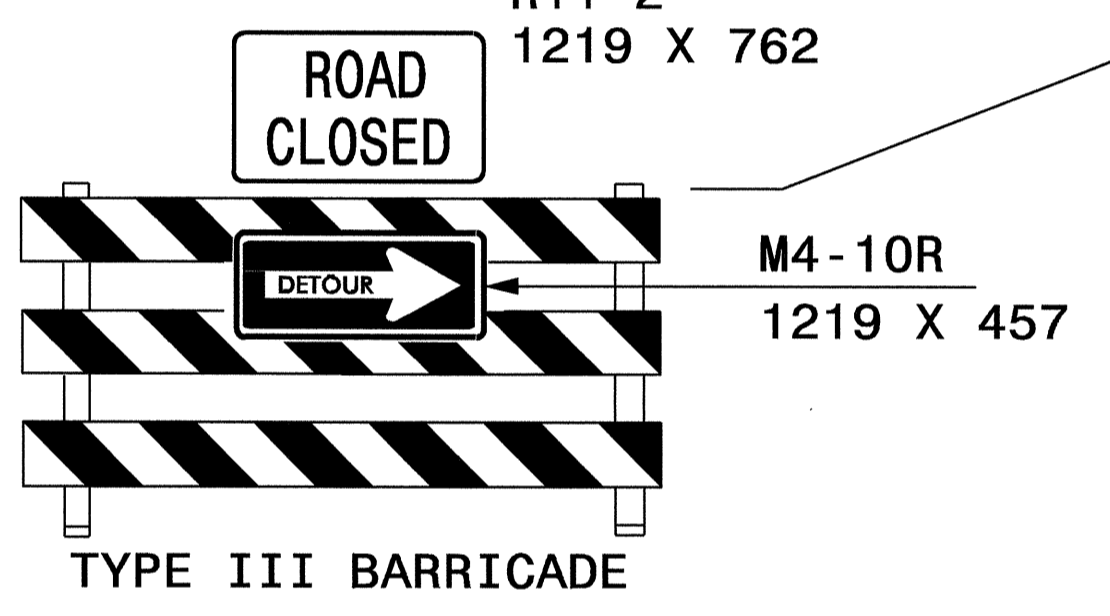
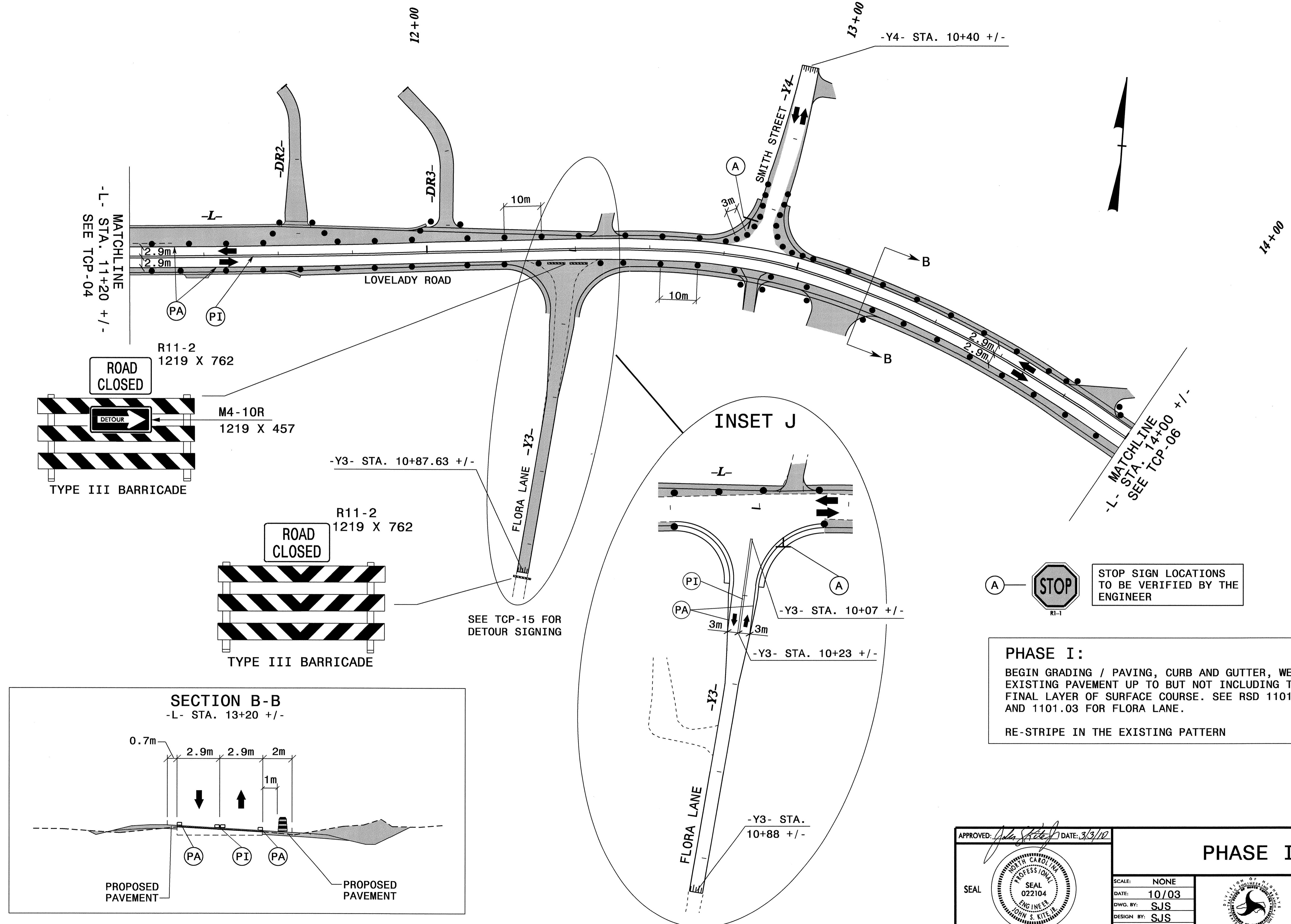

**PHASE I:**  
 BEGIN GRADING / PAVING, CURB AND GUTTER, WEDGE EXISTING PAVEMENT UP TO BUT NOT INCLUDING THE FINAL LAYER OF SURFACE COURSE. SEE RSD 1101.02 AND 1101.03 FOR FLORA LANE.  
 RE-STRIPE IN THE EXISTING PATTERN

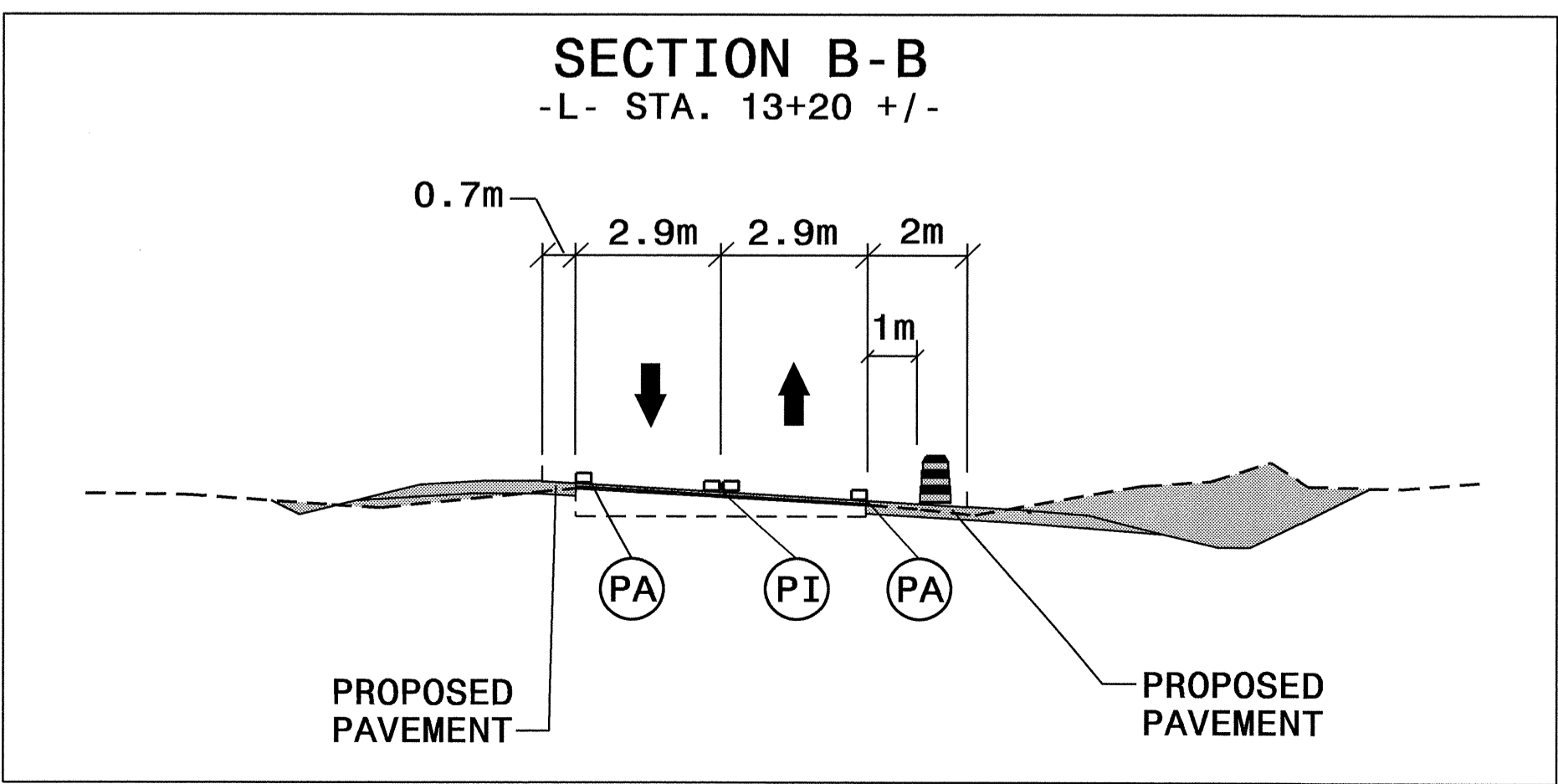

APPROVED: *[Signature]* DATE: 3/3/10

SEAL: *[Professional Engineer Seal]*

**PHASE I**

SCALE: NONE		REVISIONS
DATE: 10/03		
DWG. BY: SJS		
DESIGN BY: SJS		
REVIEWED BY: C.M.		

02-MAR-2010 15:19  
 \\dot\dfsroot\01\NSP\proj\1\IP\Projects-R\2824\TrafficControl\tcp\2824\_tcp05\_phosei.dgn  
 gkpatrel AT WZTC24748



PROJ. REFERENCE NO.	SHEET NO.
R-2824	TCP-06
BURKE	

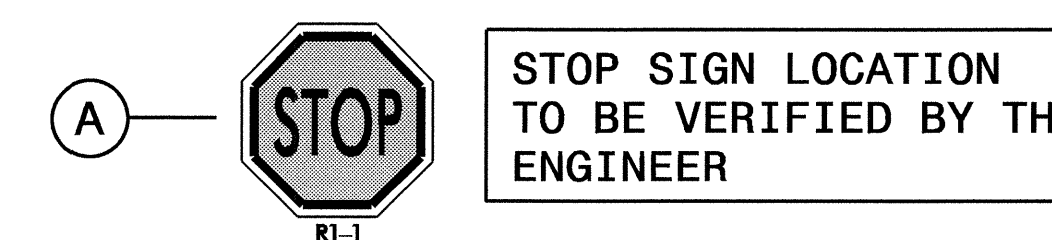
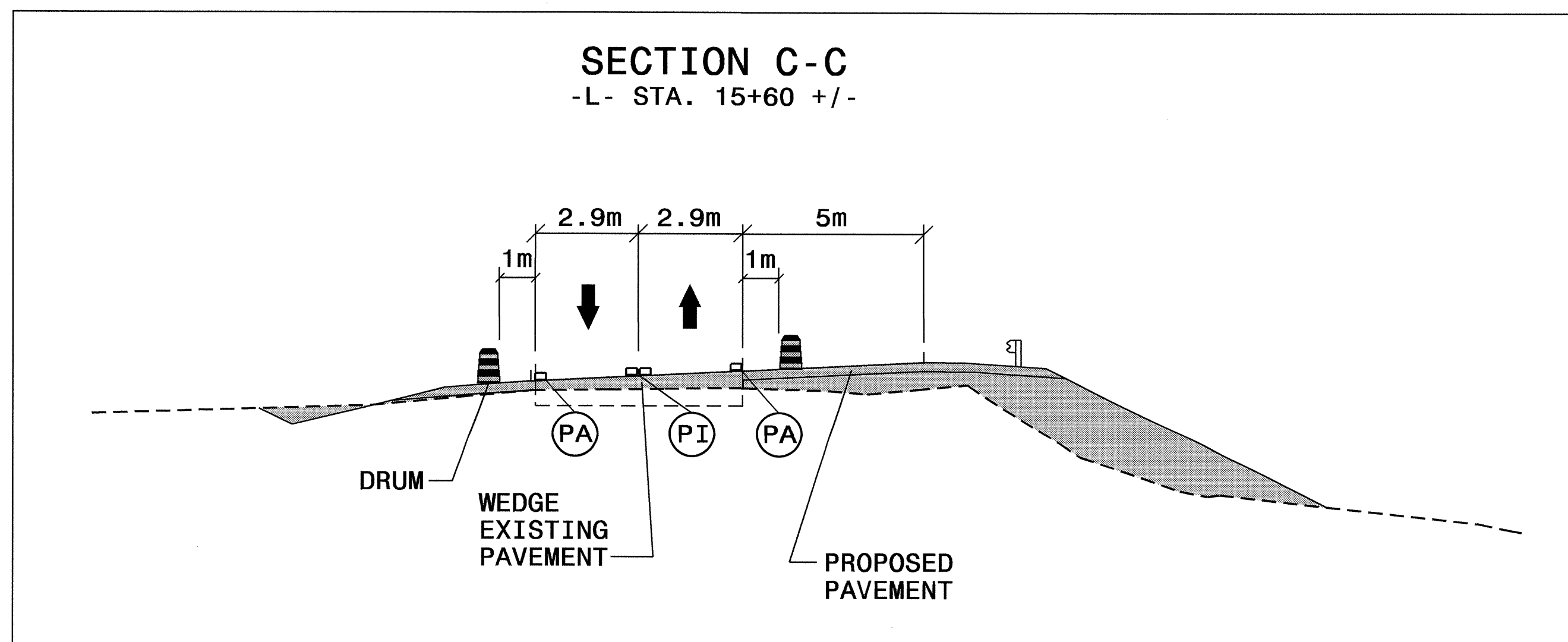
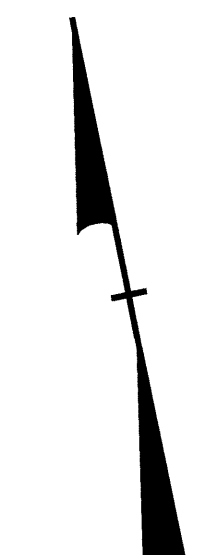
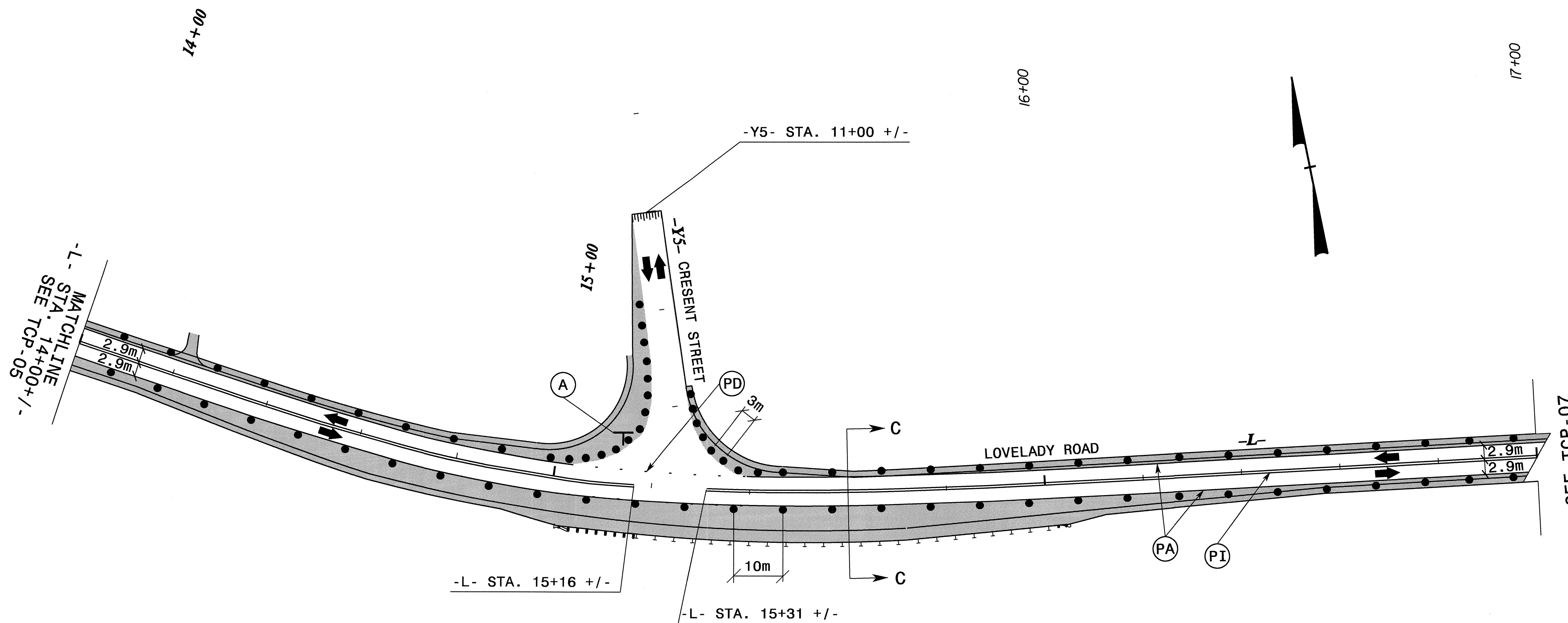

**PHASE I:**  
 BEGIN GRADING / PAVING, CURB AND GUTTER, WEDGE EXISTING PAVEMENT UP TO BUT NOT INCLUDING THE FINAL LAYER OF SURFACE COURSE.  
 RE-STRIPE IN THE EXISTING PATTERN

APPROVED: *[Signature]* DATE: 7/3/10

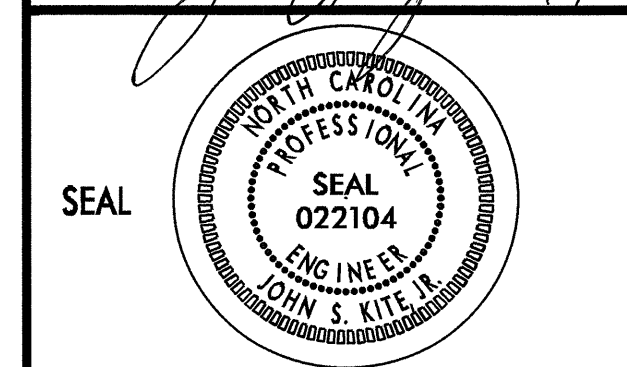

**PHASE I**

SCALE: NONE  
 DATE: 08/04  
 DWG. BY: SJS  
 DESIGN BY: SJS  
 REVIEWED BY: CLM

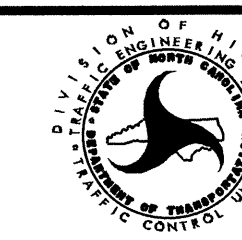

REVISIONS

02-MAR-2010 15:20  
 V:\D\1\Drawings\NSP\Projects\RR2824\TrafficControl\tcp\2824\_tcp06\_phase1.dgn  
 ckd\del AT WZTC24748



PROJ. REFERENCE NO.	SHEET NO.
R-2824	TCP-07
BURKE	

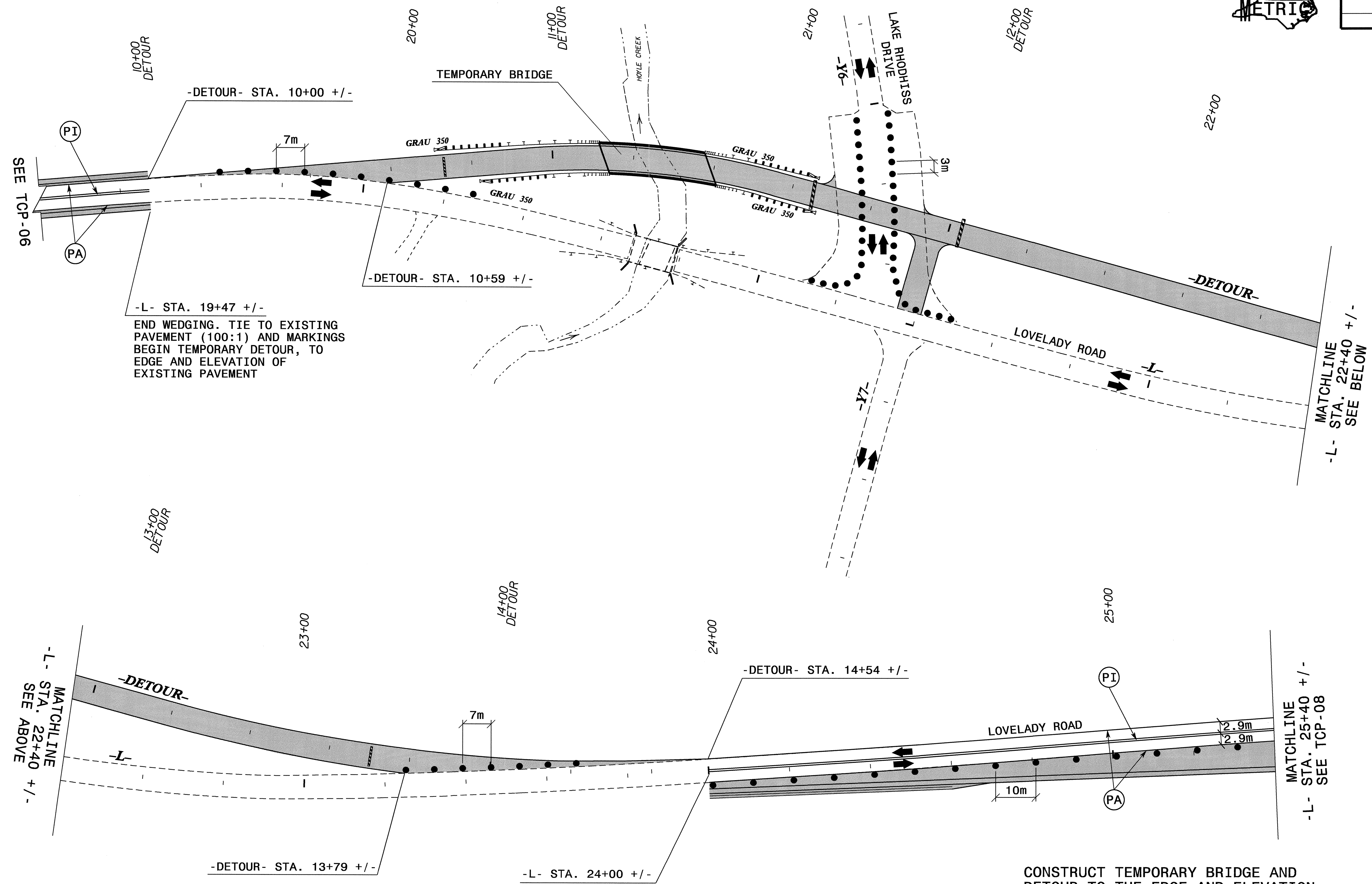

-L- STA. 19+47 +/-  
 END WEDGING. TIE TO EXISTING PAVEMENT (100:1) AND MARKINGS BEGIN TEMPORARY DETOUR, TO EDGE AND ELEVATION OF EXISTING PAVEMENT

CONSTRUCT TEMPORARY BRIDGE AND DETOUR TO THE EDGE AND ELEVATION OF EXISTING PAVEMENT

02-MAR-2010 15:21  
 \\Dc1\dfs\c\010\NSP\proj\TIP\Projects-R\R2824\TrafficControl\tcp\2824\_tcp07\_phase1.dgn  
 okp@tel.at WZTC24748

APPROVED: *[Signature]* DATE: 3/3/10



**PHASE I**

SCALE:	NONE
DATE:	10/03
DWG. BY:	SJS
DESIGN BY:	SJS
REVIEWED BY:	CLM



REVISIONS	





PROJ. REFERENCE NO.	SHEET NO.
R-2824	TCP-08
BURKE	

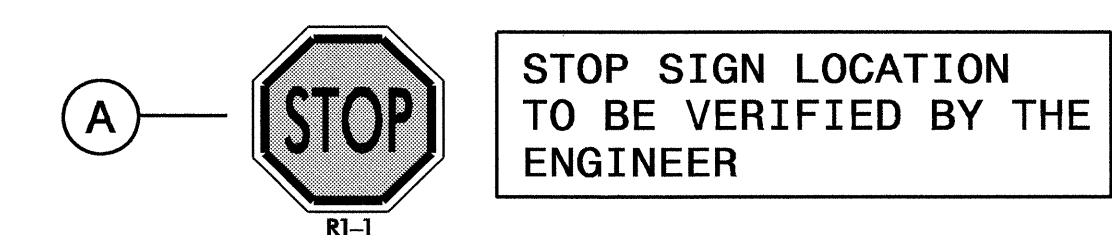
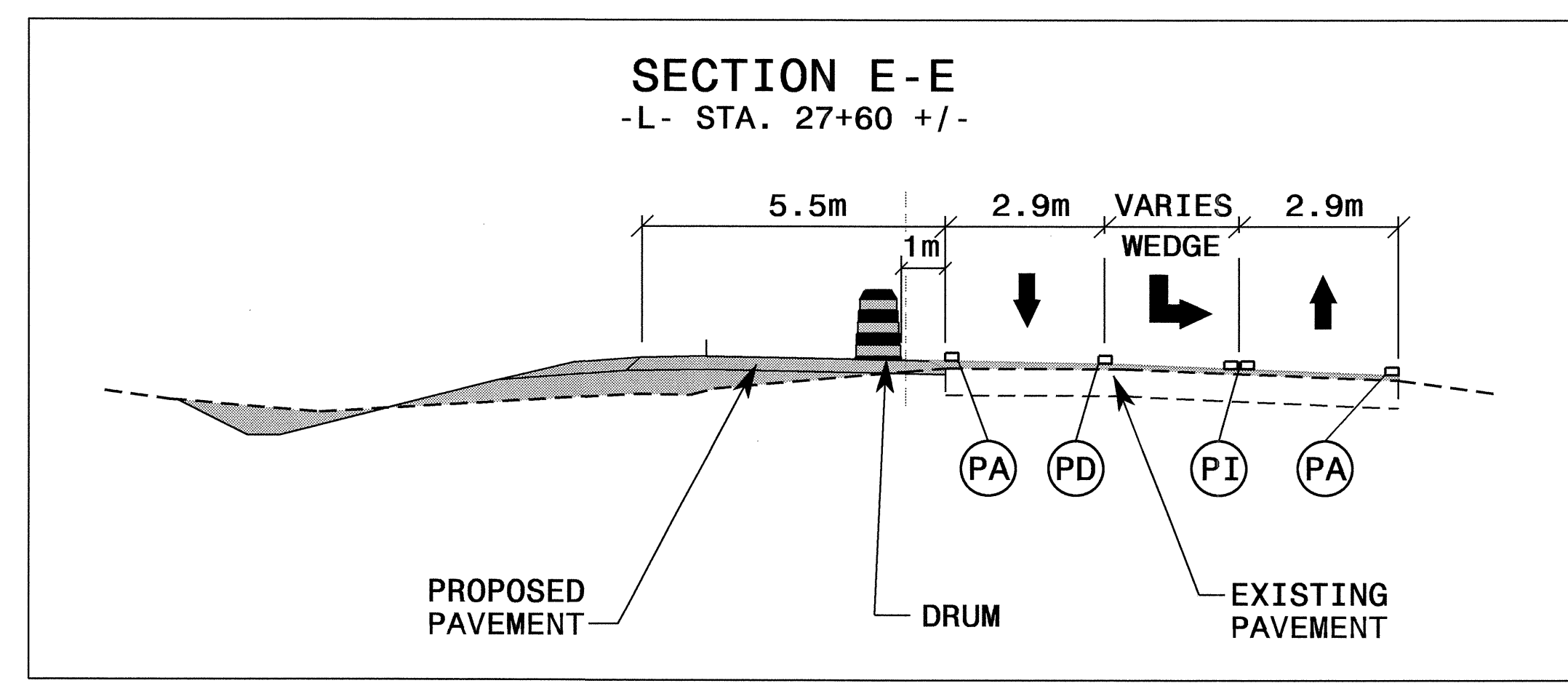
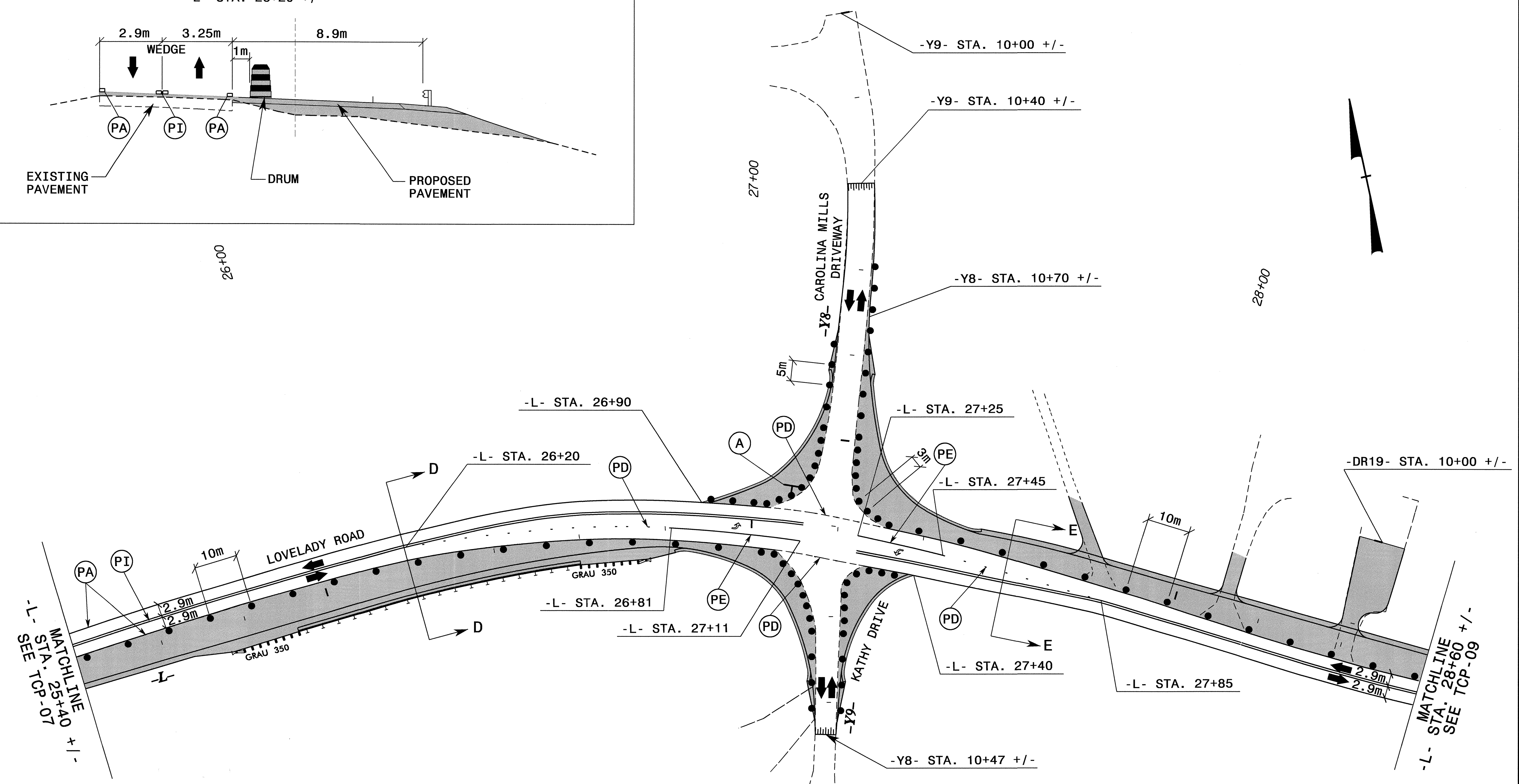
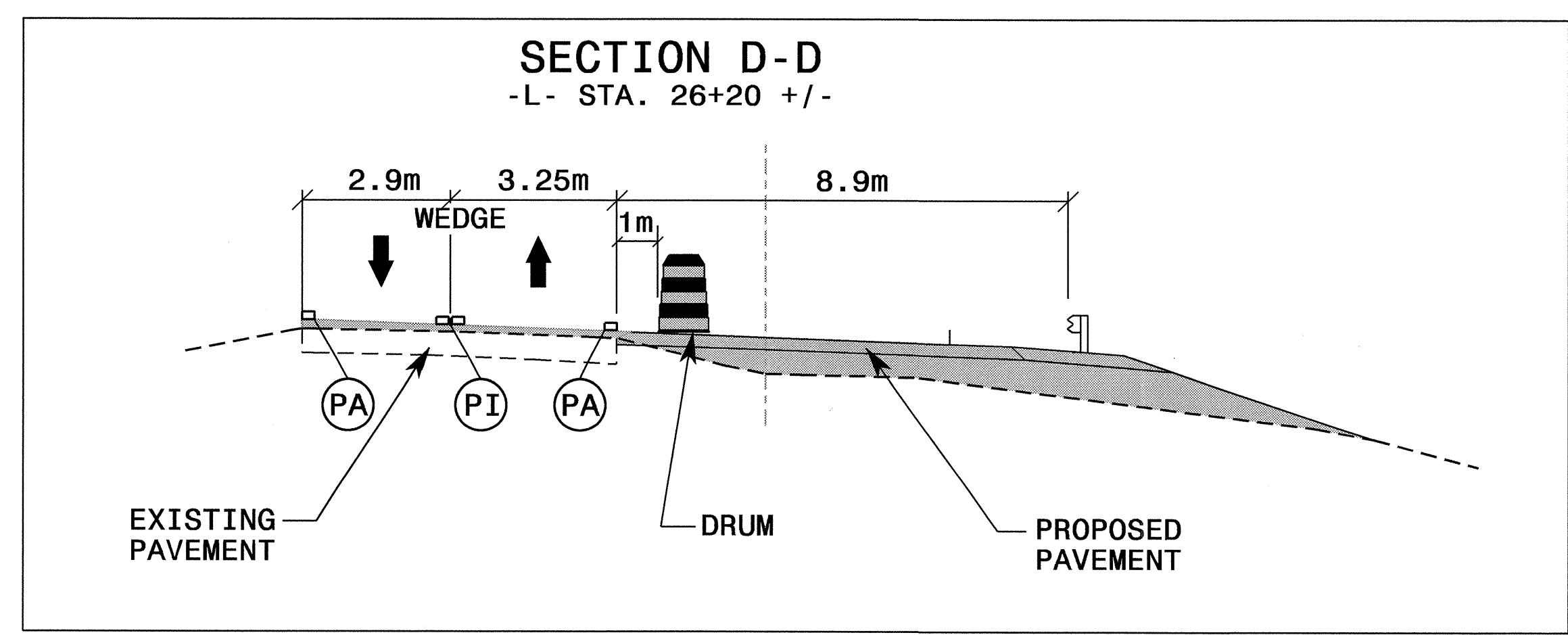

APPROVED: *[Signature]* DATE: 3/3/10

SEAL

**PHASE I**

SCALE: NONE		<table border="1"> <tr> <th colspan="2">REVISIONS</th> </tr> <tr> <td> </td> <td> </td> </tr> <tr> <td> </td> <td> </td> </tr> <tr> <td> </td> <td> </td> </tr> </table>	REVISIONS							
REVISIONS										
DATE: 10/03										
DESIGN BY: SJS										
REVIEWED BY: CLM										

02-MAR-2010 15:21  
 \\dot\dfsroot\NSProj\TIPProj\Projects-R\R2824\TrafficControl\tcp08.phosei.dgn  
 dkpatel AT WZTC244748



PROJ. REFERENCE NO.	SHEET NO.
R-2824	TCP-09
BURKE	

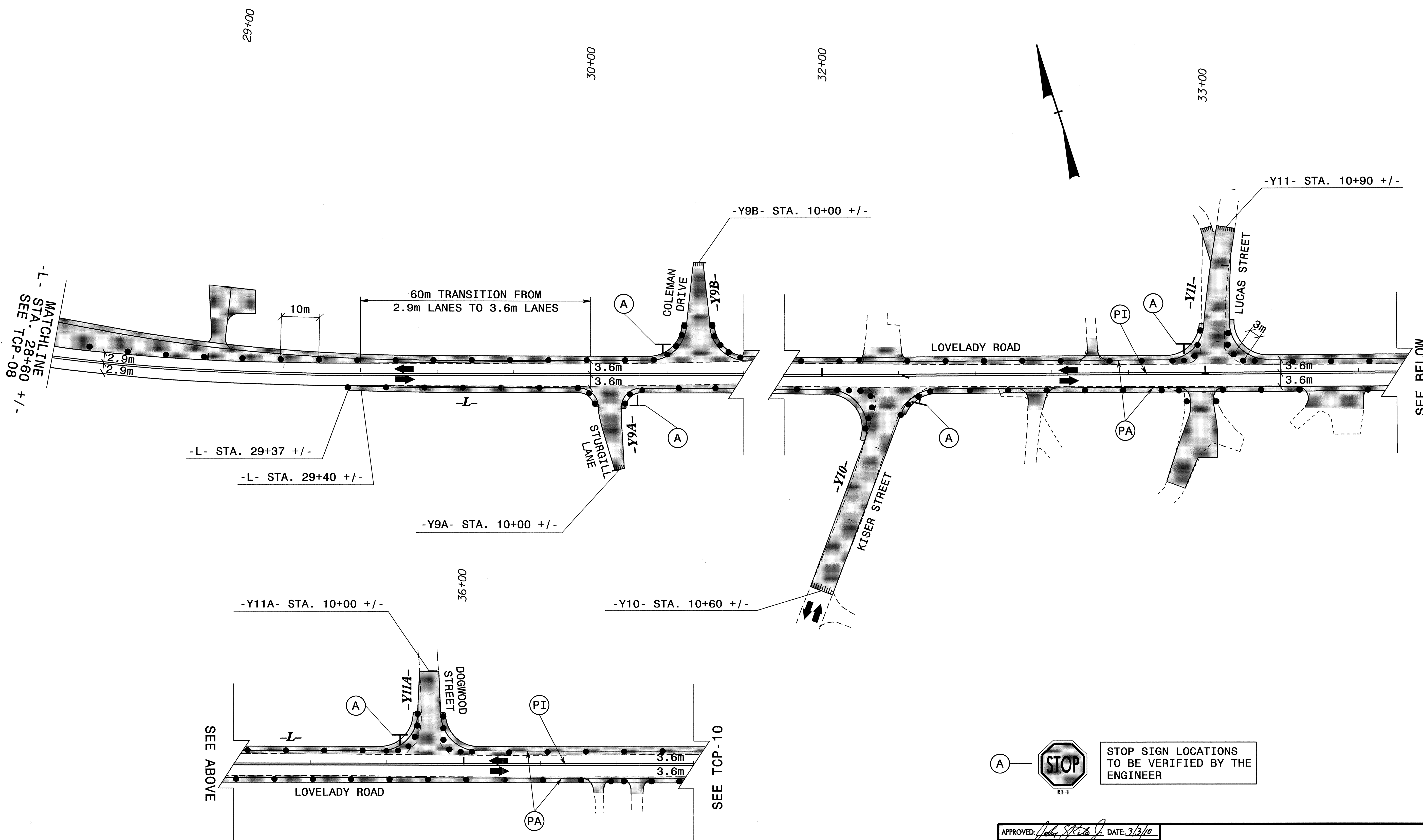

MATCHLINE  
-L- STA. 28+60 +/-  
SEE TCP-08

SEE BELOW

-L- STA. 29+37 +/-  
-L- STA. 29+40 +/-

-Y9A- STA. 10+00 +/-

-Y9B- STA. 10+00 +/-

-Y10- STA. 10+60 +/-

-Y11A- STA. 10+00 +/-

SEE ABOVE

SEE TCP-10

(A) STOP  
RI-1

STOP SIGN LOCATIONS  
TO BE VERIFIED BY THE  
ENGINEER

APPROVED: *[Signature]* DATE: 3/3/10

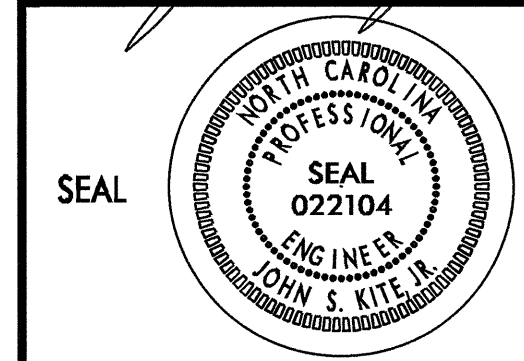

### PHASE I

SCALE: NONE  
DATE: 09/04  
DWG. BY: SJS  
DESIGN BY: SJS  
REVIEWED BY: CLM

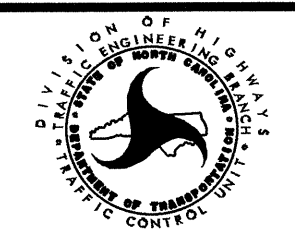

REVISIONS	

02-MAR-2010 15:23  
\\dot\dfsroot\010\NSP\proj\TIP\Project\RR2824\TrafficControl\tcp\2824\_tcp09\_phase1.dgn  
okpotel AT WZTC244748



PROJ. REFERENCE NO.	SHEET NO.
R-2824	TCP-10
BURKE	

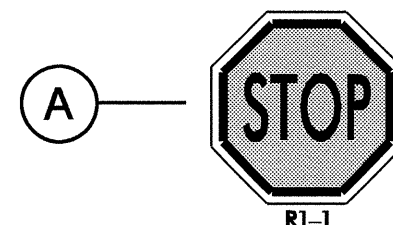
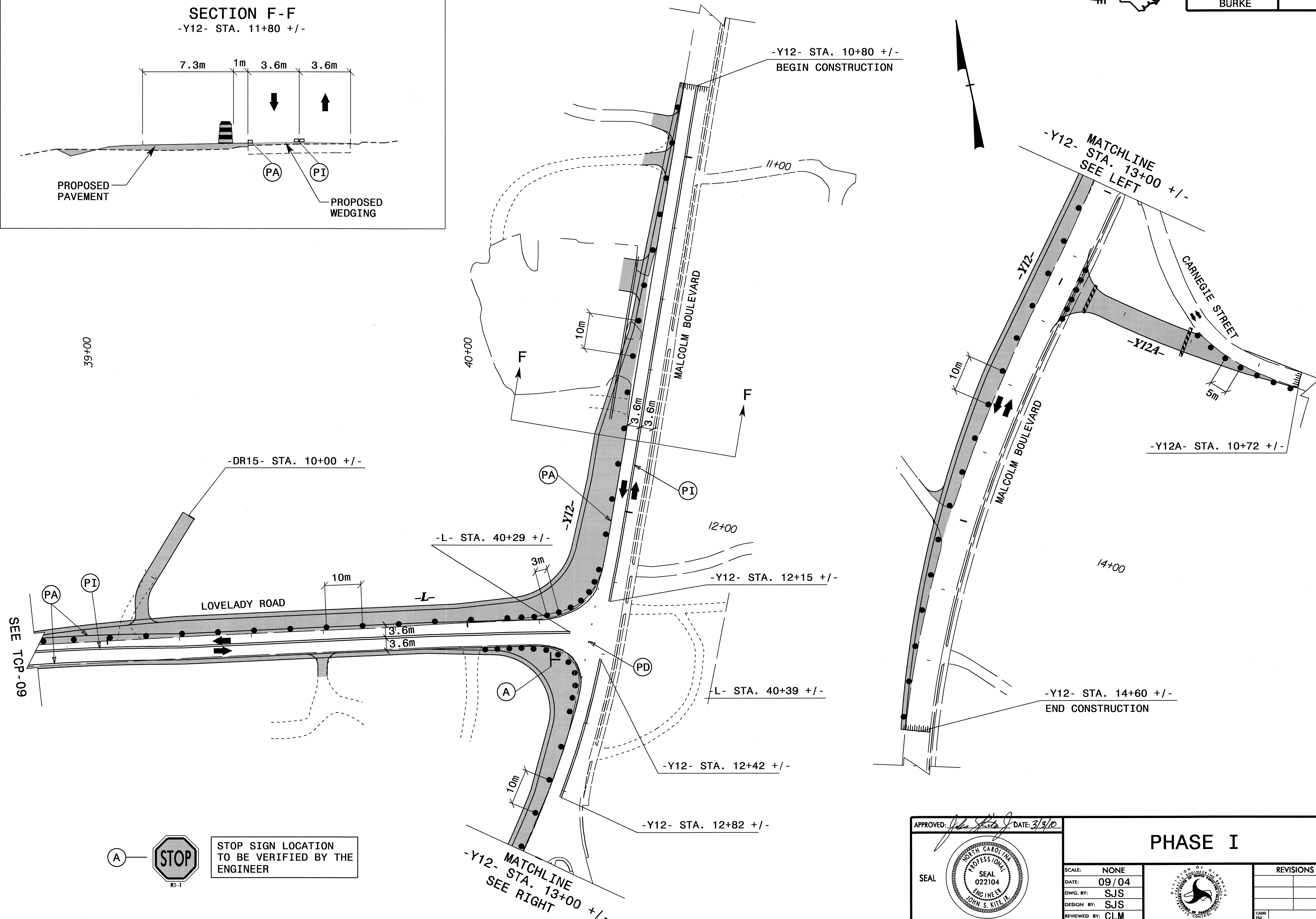
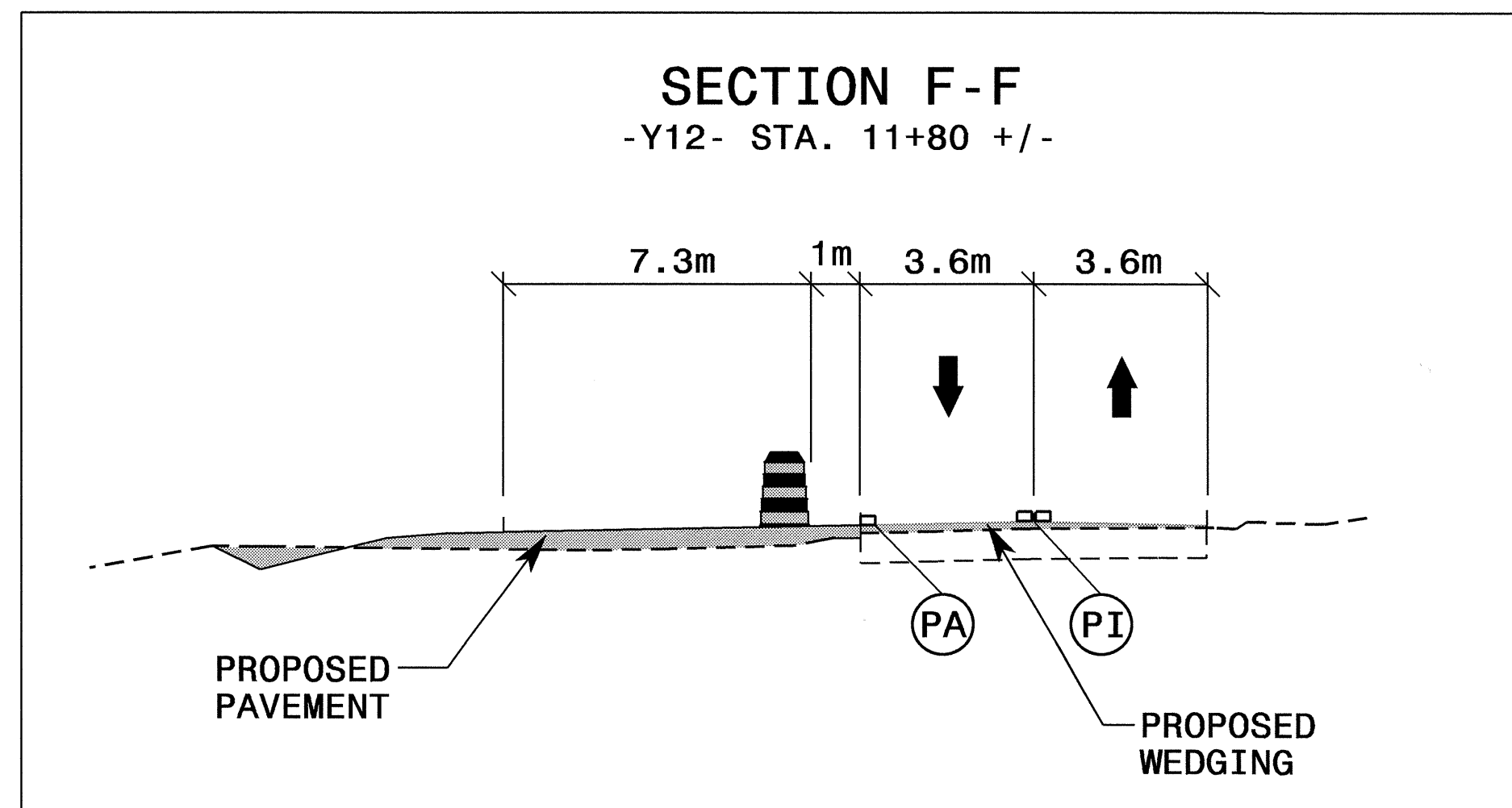

STOP SIGN LOCATION TO BE VERIFIED BY THE ENGINEER

MATCHLINE  
-Y12- STA. 13+00 +/-  
SEE RIGHT

APPROVED: <i>[Signature]</i> DATE: 3/3/10	<b>PHASE I</b>	
SCALE: NONE	REVISIONS	
DATE: 09/04		
DWG. BY: SJS		
DESIGN BY: SJS		
REVIEWED BY: CLM		<small>CADD FILE</small>

02-MAR-2010 15:24  
 \\dot\dfsroot\01\NSP\proj\TIP\Projects-R\R2824\TrafficControl\tcp\2824\_tcp10\_phase1.dgn  
 gkpatel AT WZTC24748



PROJ. REFERENCE NO.	SHEET NO.
R-2824	TCP-11
BURKE	

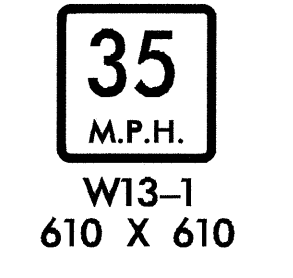
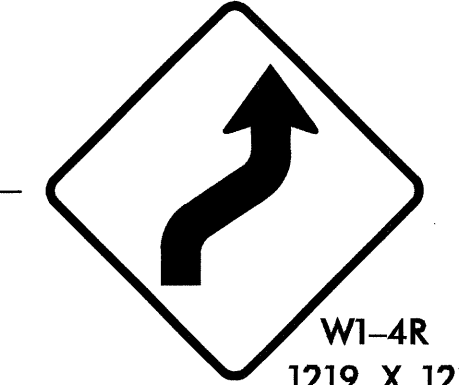
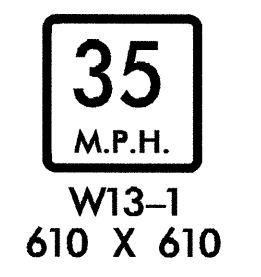
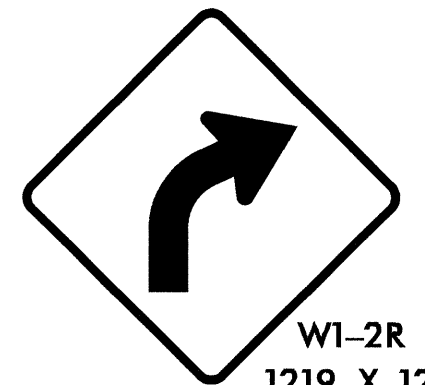
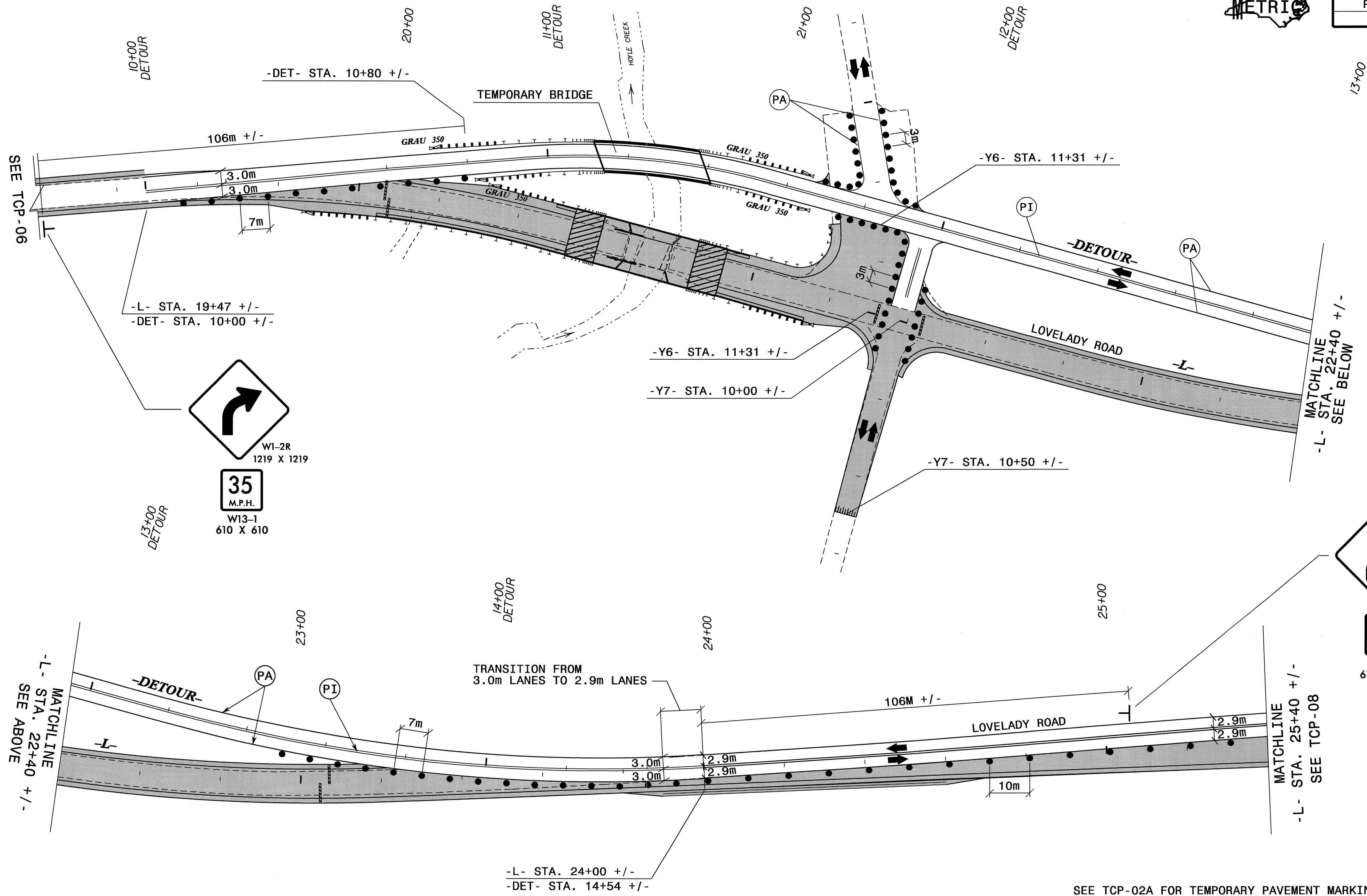

02-MAR-2010 15:25  
 \\dot\dfs\010\NSProj\TIP\Projects-RV2824\TrafficControl\tcp.r.2824.tcpl.phasel.dgn  
 gkdotel AT W7TC244748

SEE TCP-02A FOR TEMPORARY PAVEMENT MARKING SCHEDULE

APPROVED:  DATE: 3/3/10	<b>PHASE II</b>		REVISIONS	
			SCALE: NONE	
	DATE: 10/03			
	DWG. BY: SJS			
	DESIGN BY: SJS			
REVIEWED BY: CLM				



PROJ. REFERENCE NO.	SHEET NO.
R-2824	TCP-12
BURKE	

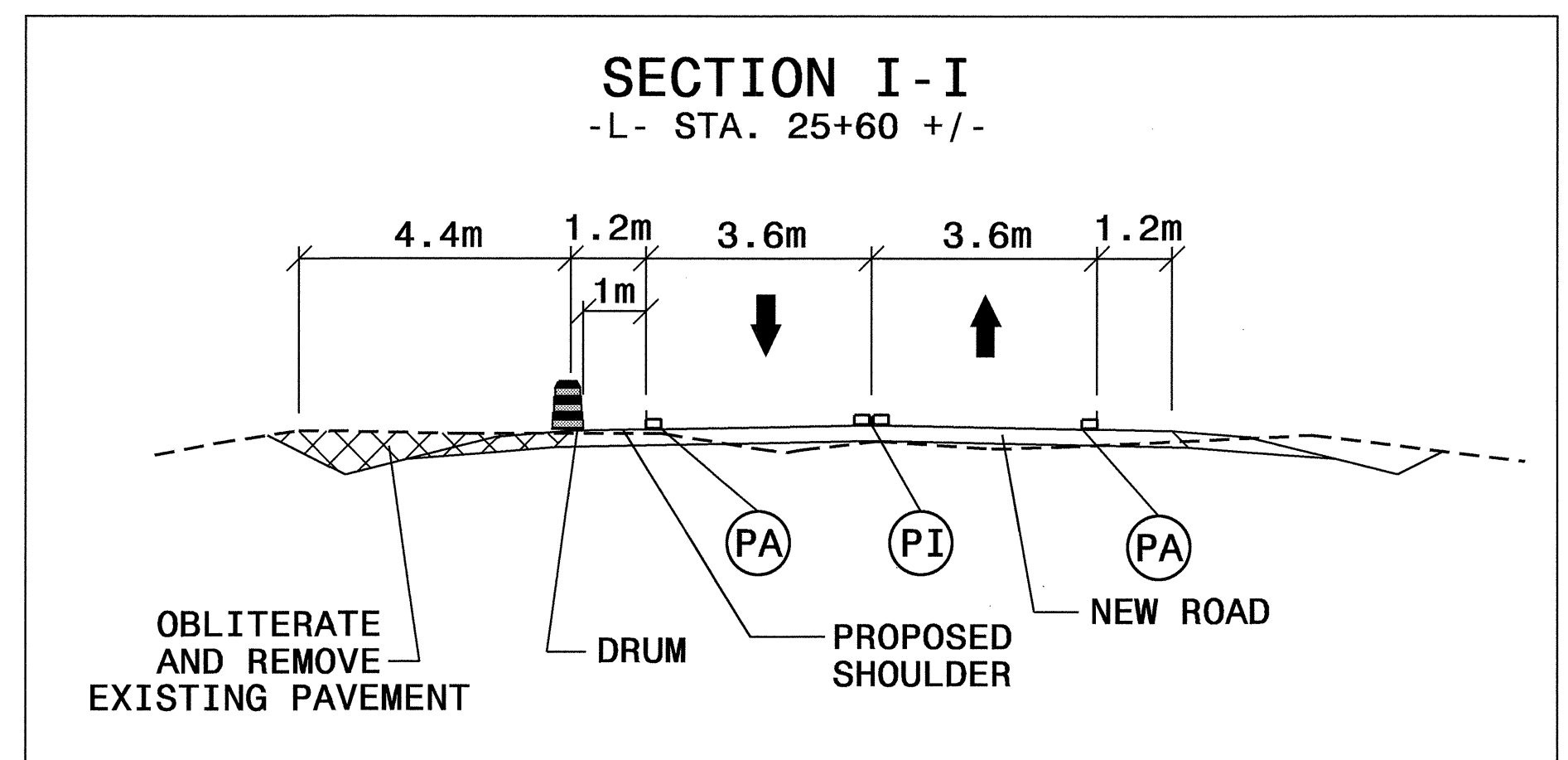
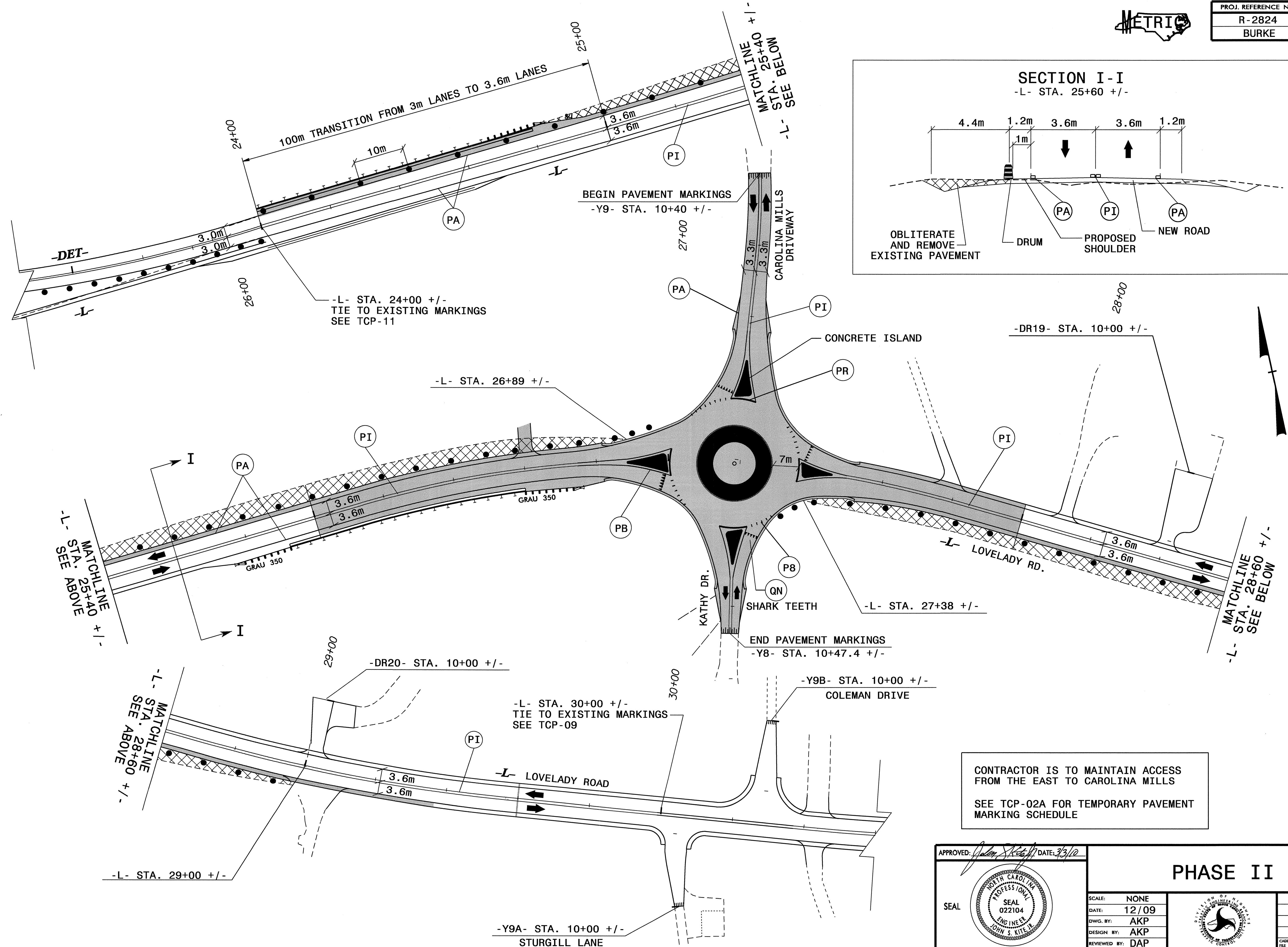

CONTRACTOR IS TO MAINTAIN ACCESS FROM THE EAST TO CAROLINA MILLS

SEE TCP-02A FOR TEMPORARY PAVEMENT MARKING SCHEDULE

APPROVED: *[Signature]* DATE: 3/3/10

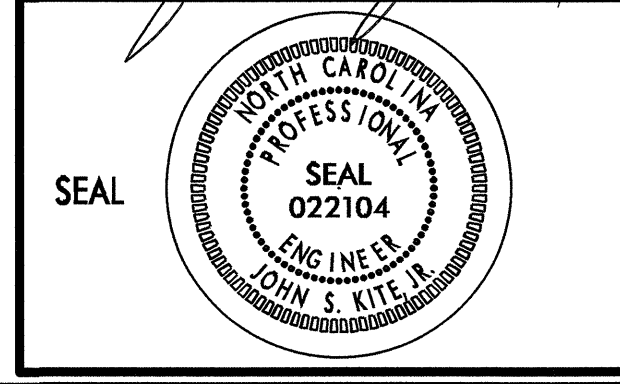

PHASE II

SCALE:	NONE
DATE:	12/09
DWG. BY:	AKP
DESIGN BY:	AKP
REVIEWED BY:	DAP



REVISIONS

02-MAR-2010 15:26  
 \\dot\dfs\0010\NSP\proj\TIP\projects-R\2824\TrafficControl\tcp\2824\_tcp12\_phasel2.dgn  
 akp\del AT W7TC244748



PROJ. REFERENCE NO.	SHEET NO.
R-2824	TCP-13
BURKE	

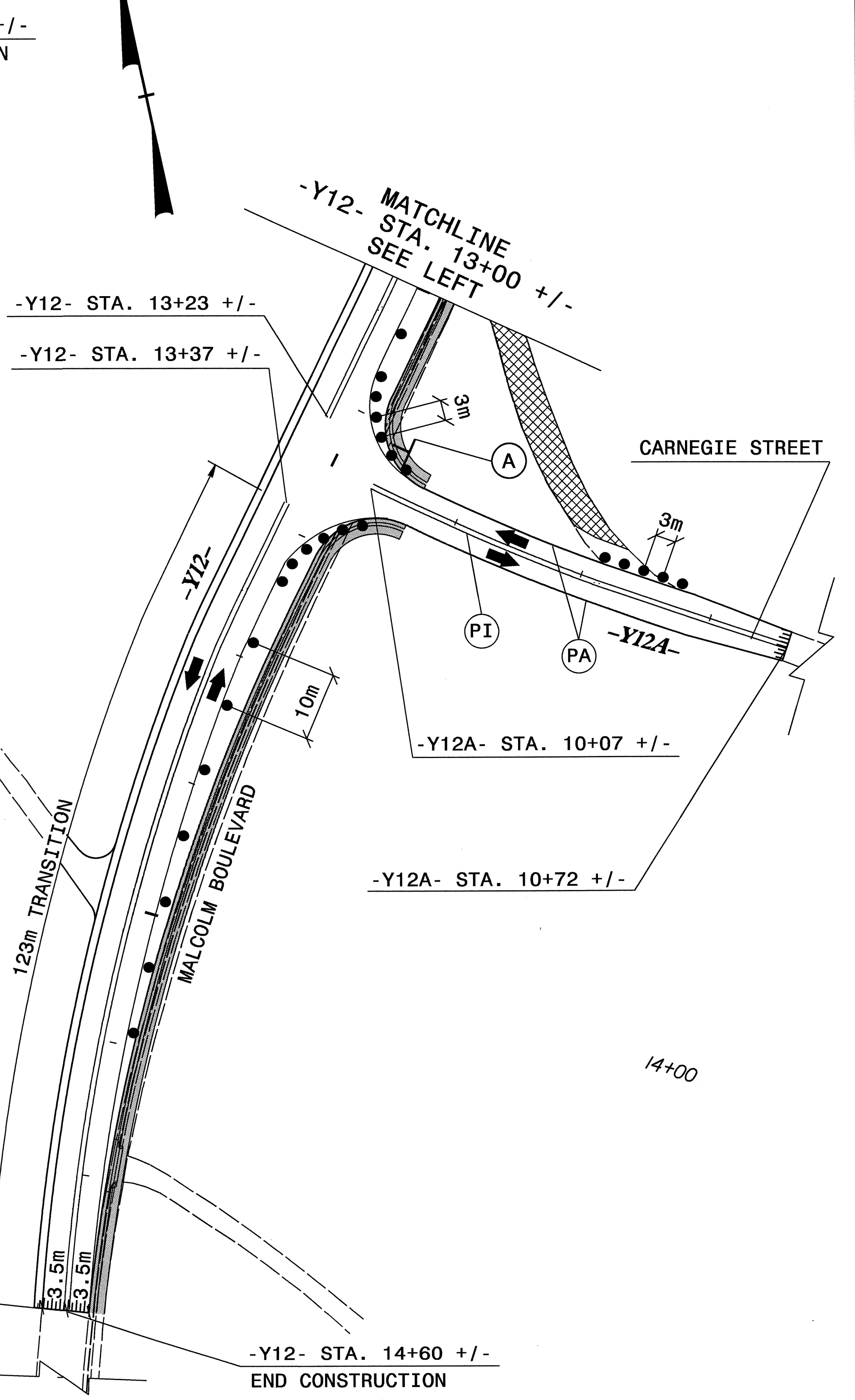
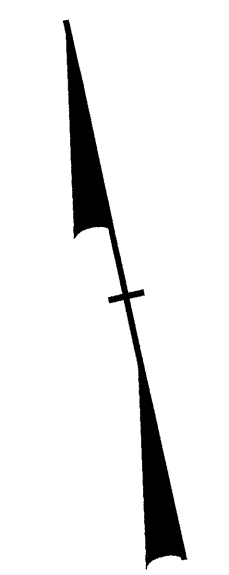
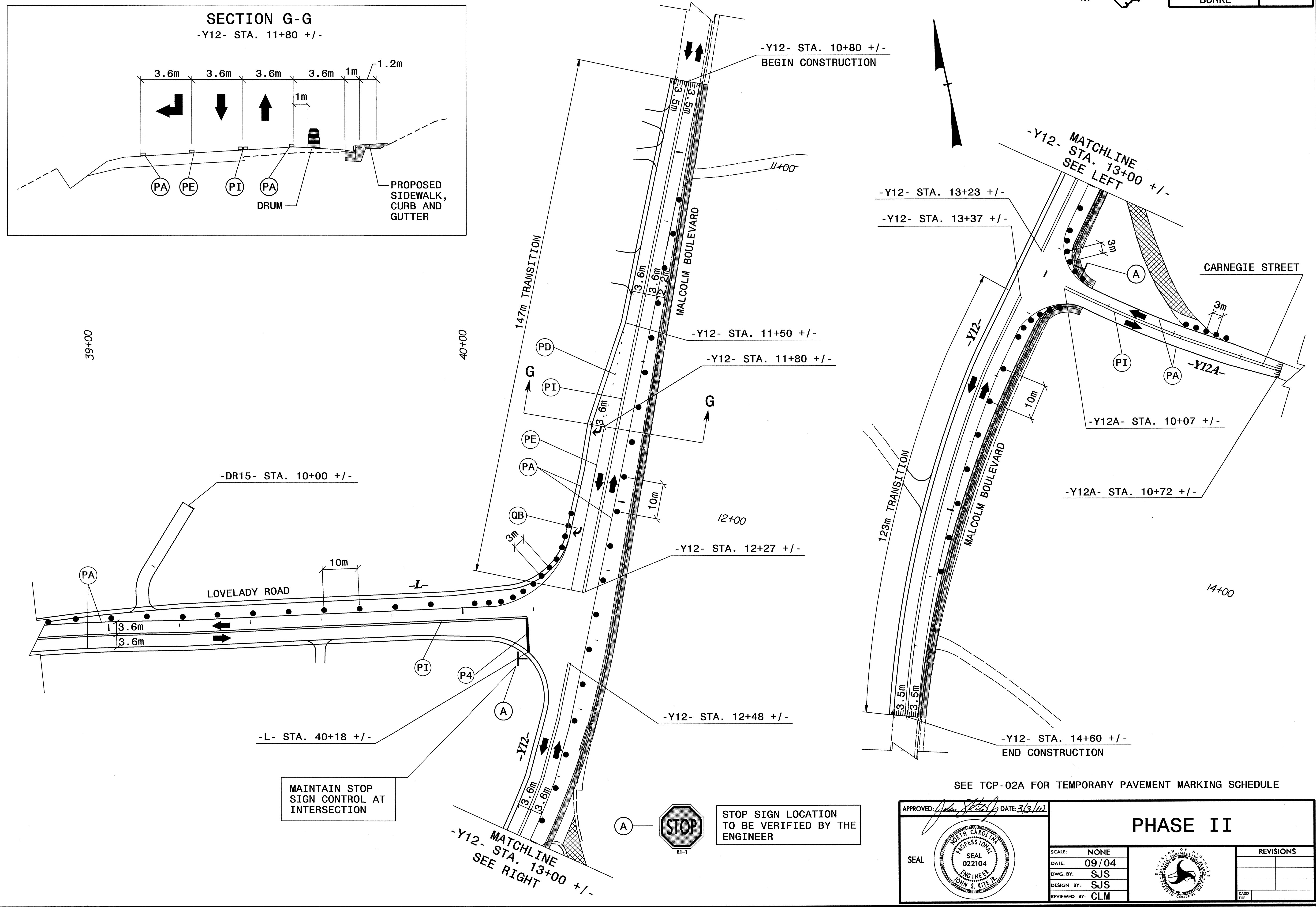
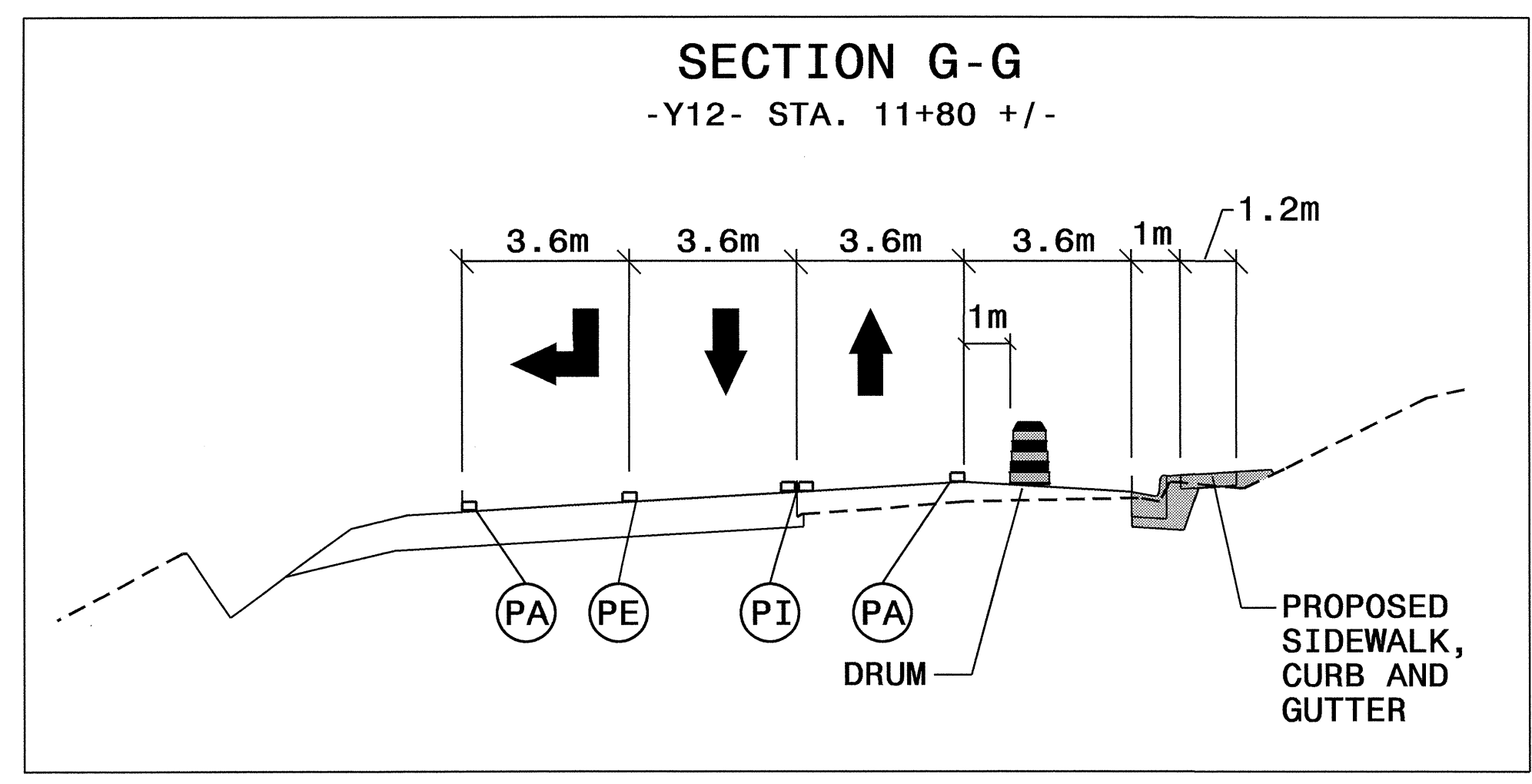

MAINTAIN STOP SIGN CONTROL AT INTERSECTION

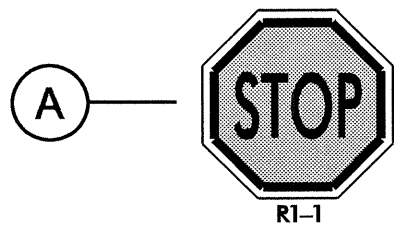

STOP SIGN LOCATION TO BE VERIFIED BY THE ENGINEER

SEE TCP-Q2A FOR TEMPORARY PAVEMENT MARKING SCHEDULE

APPROVED: *[Signature]* DATE: 3/3/12

SEAL

<b>PHASE II</b>		REVISIONS	
SCALE:	NONE		
DATE:	09/04		
DWG. BY:	SJS		
DESIGN BY:	SJS		
REVIEWED BY:	CLM		

02-MAR-2010 15:27  
 \\dot\dfsroot\NSP\Projects-R\2824\TrafficControl\TCP-13\TCP13-phases.dgn  
 dkpatel AT WZTC244748



PROJ. REFERENCE NO.	SHEET NO.
R-2824	TCP-14
BURKE	

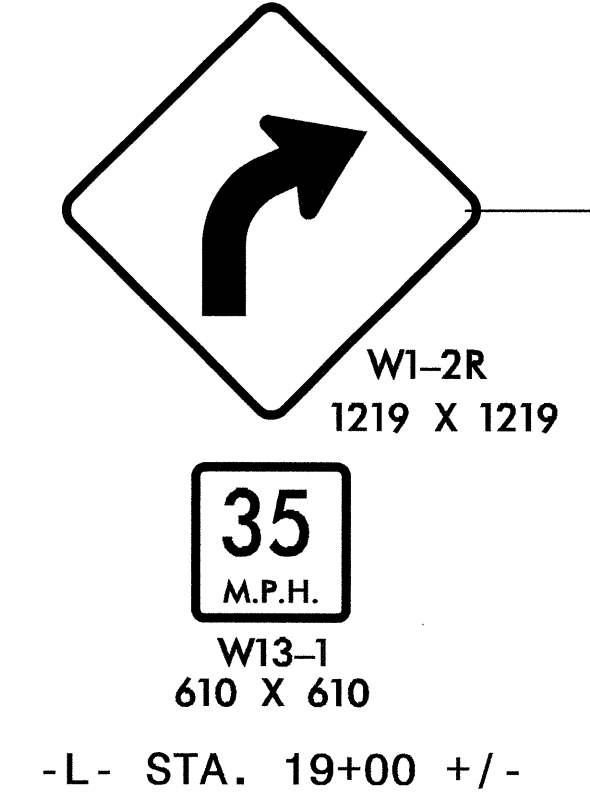
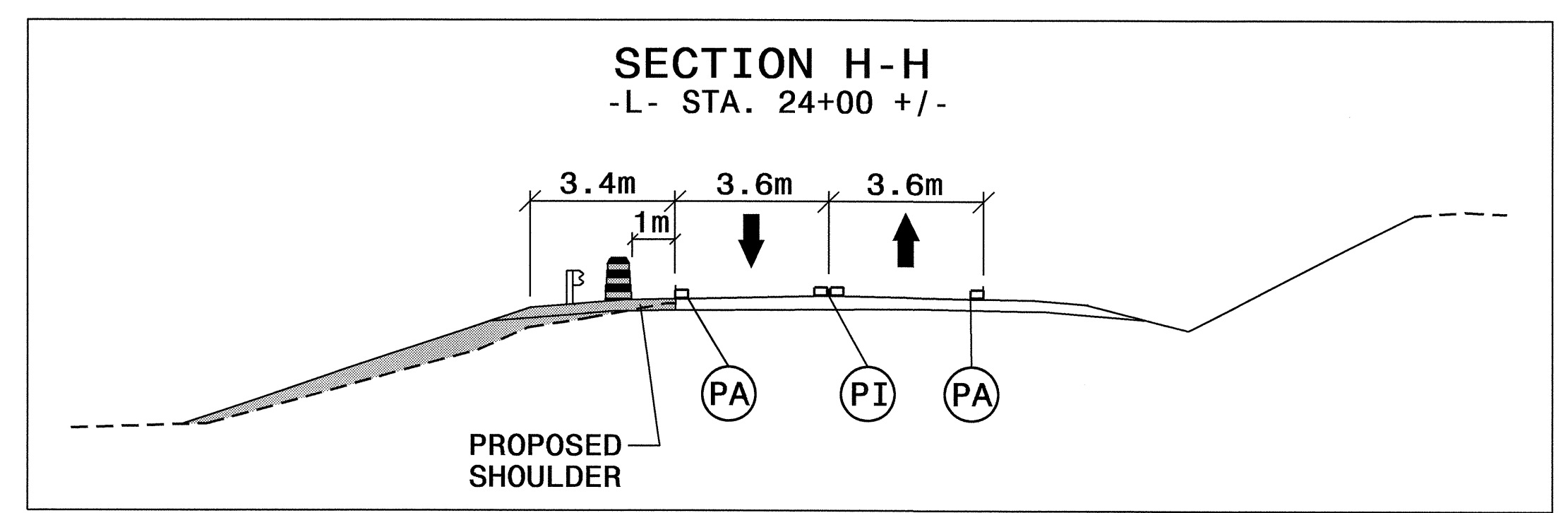
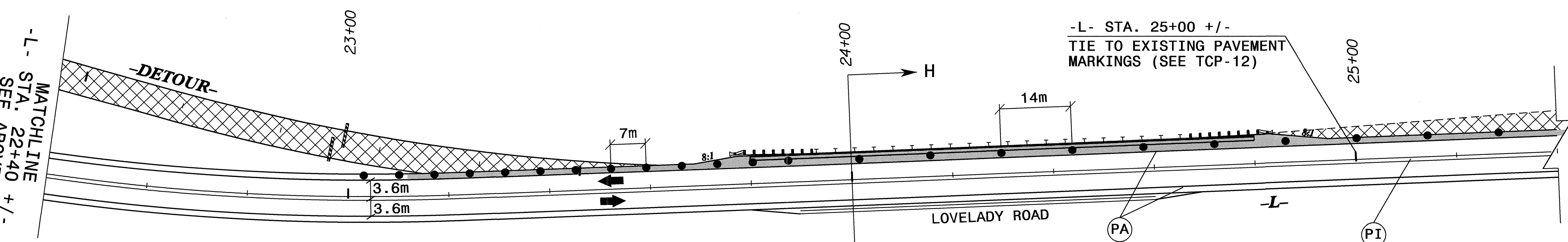
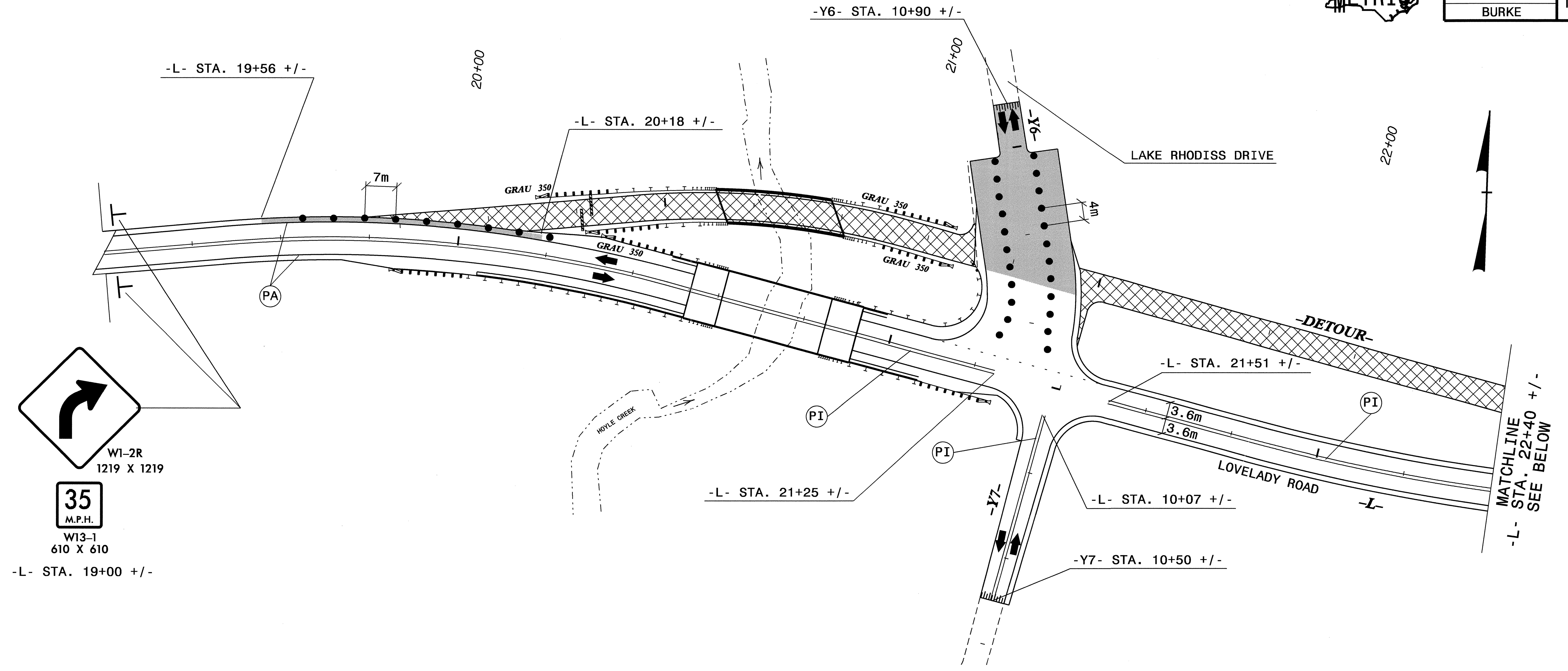

SEE TCP-02A FOR TEMPORARY PAVEMENT MARKING SCHEDULE

APPROVED: *[Signature]* DATE: 3/3/10

SEAL:

### PHASE III

SCALE:	NONE
DATE:	09/04
DWG. BY:	SJS
DESIGN BY:	SJS
REVIEWED BY:	CLM

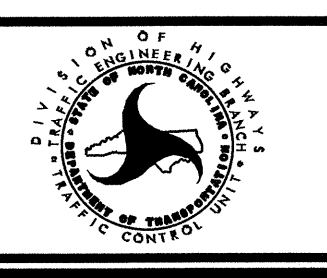

NO.	REVISIONS

02-MAR-2010 15:29 \\dot\dfsroot\NSP\proj\TIP\Projects-R\2824\TrafficControl\top\2824\_tcp14\_phosell.dgn



PROJ. REFERENCE NO.	SHEET NO.
R-2824	TCP-15
BURKE	

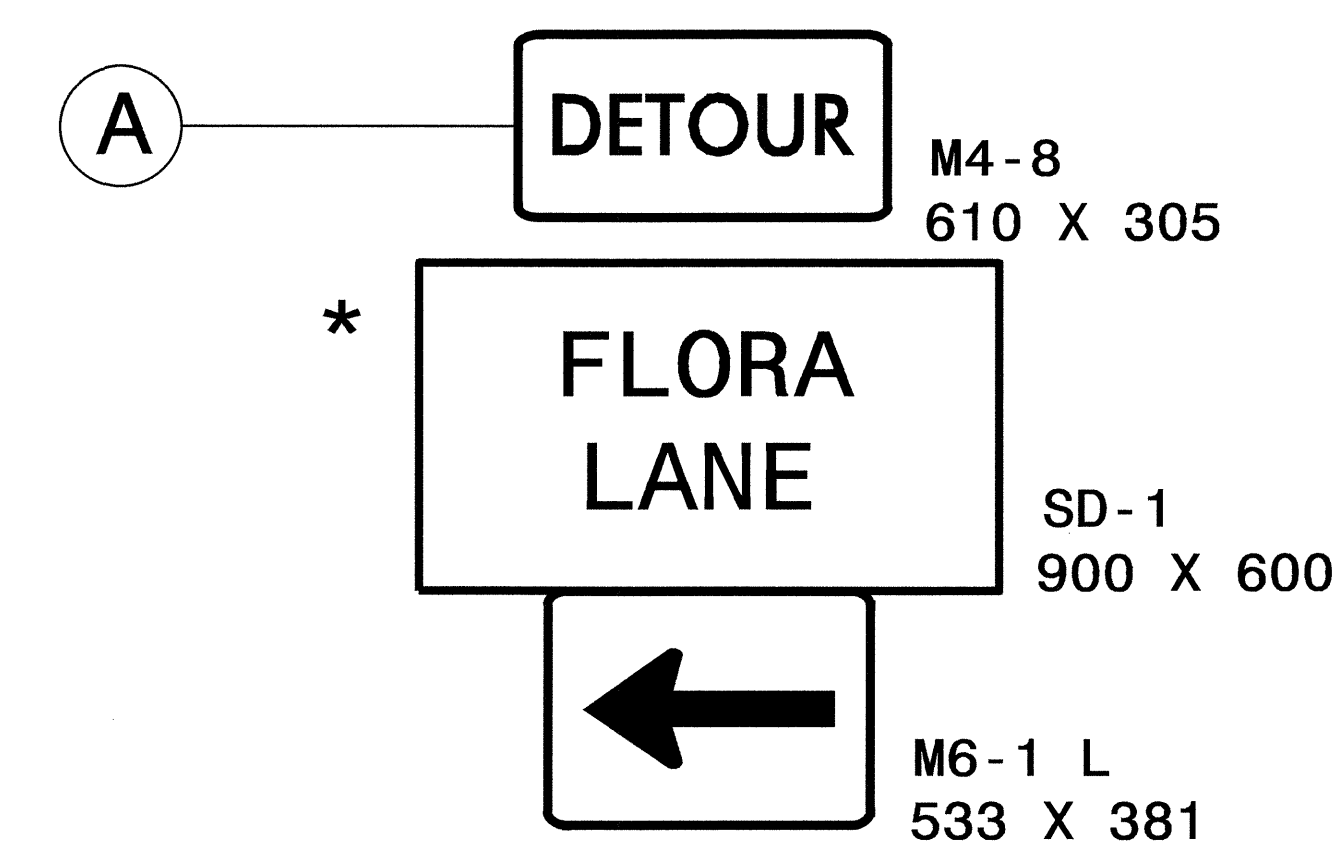
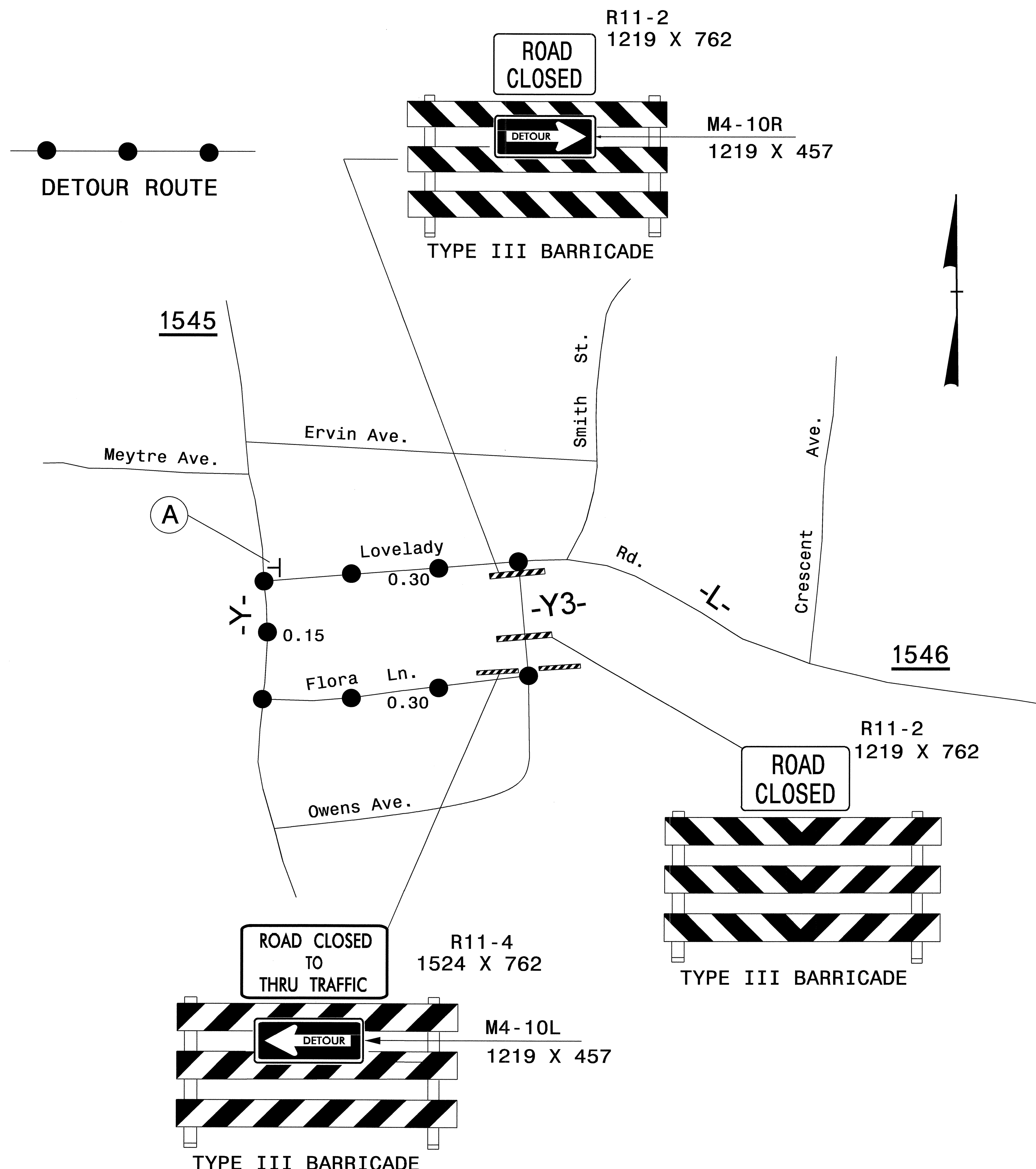

\*SEE SD-1 FOR SPECIAL SIGN DESIGN

02-MAR-2010 15:30  
 \\dot\dfsroot\0\NSP\proj\TIP\Projects-R\2824\TrafficControl\top\2824\_tcp15\_detour.dgn  
 akpote AT WZTC24748

APPROVED: <i>John S. Kite</i> DATE: 3/3/10	<b>-Y3- DETOUR ROUTE AND SIGNING</b>									
SCALE: NONE	DATE: 9/04	<table border="1"> <thead> <tr> <th colspan="2">REVISIONS</th> </tr> </thead> <tbody> <tr><td> </td><td> </td></tr> <tr><td> </td><td> </td></tr> <tr><td> </td><td> </td></tr> </tbody> </table>	REVISIONS							
REVISIONS										
DWG. BY: SJS	DESIGN BY: SJS									
REVIEWED BY: CLM										





PROJ. REFERENCE NO.	SHEET NO.
R-2824	TCP-16
BURKE	

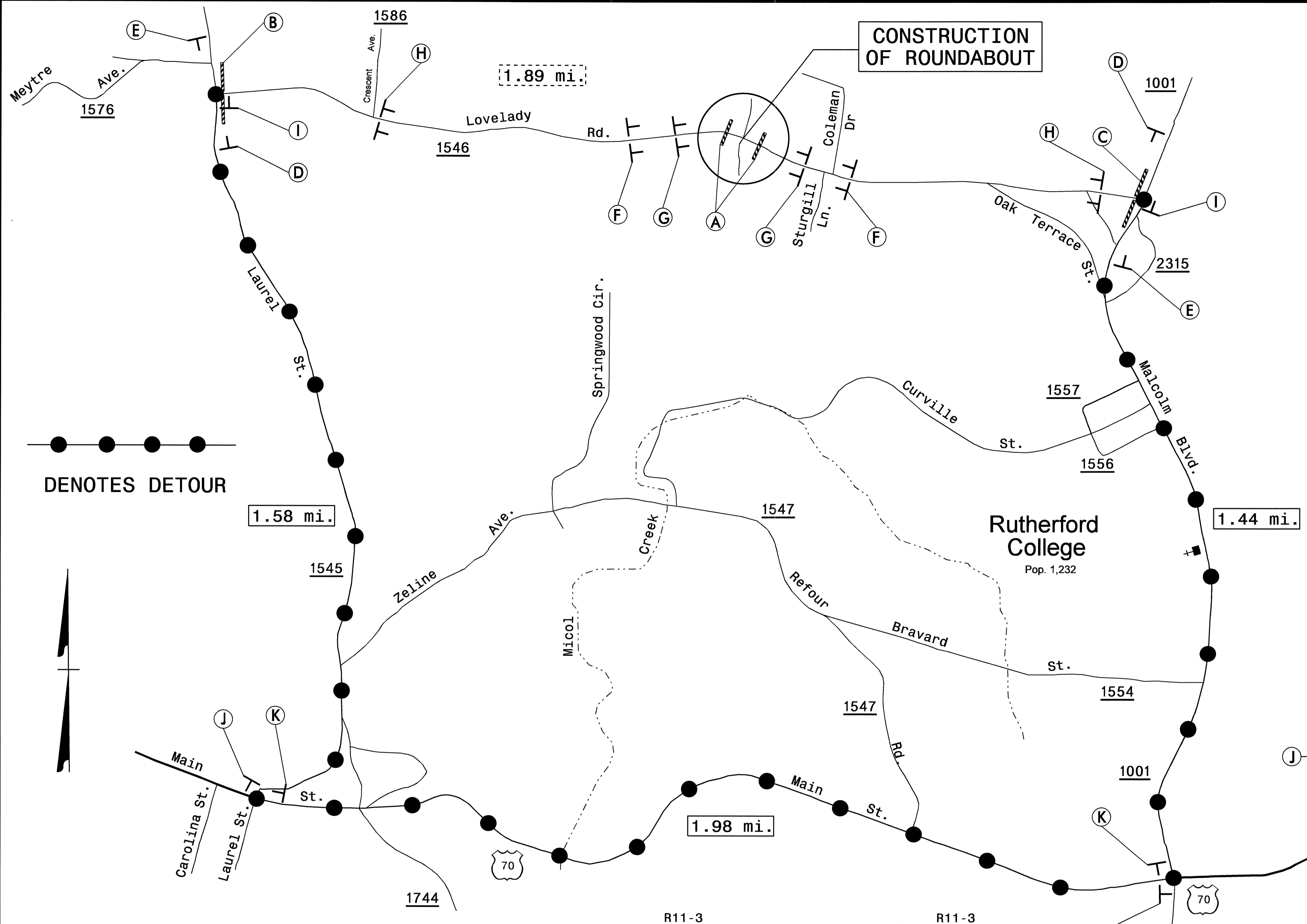

DENOTES DETOUR

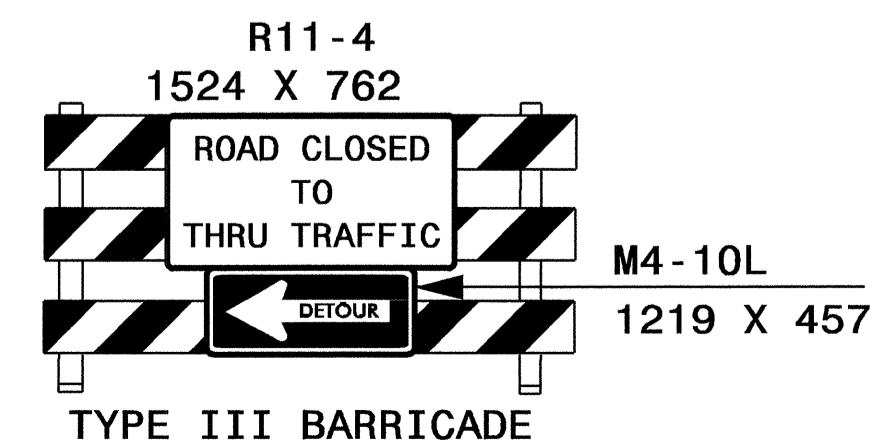
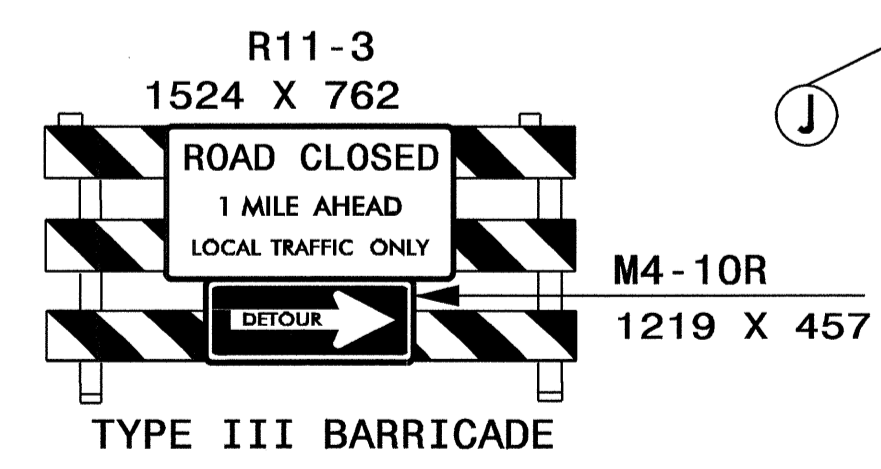
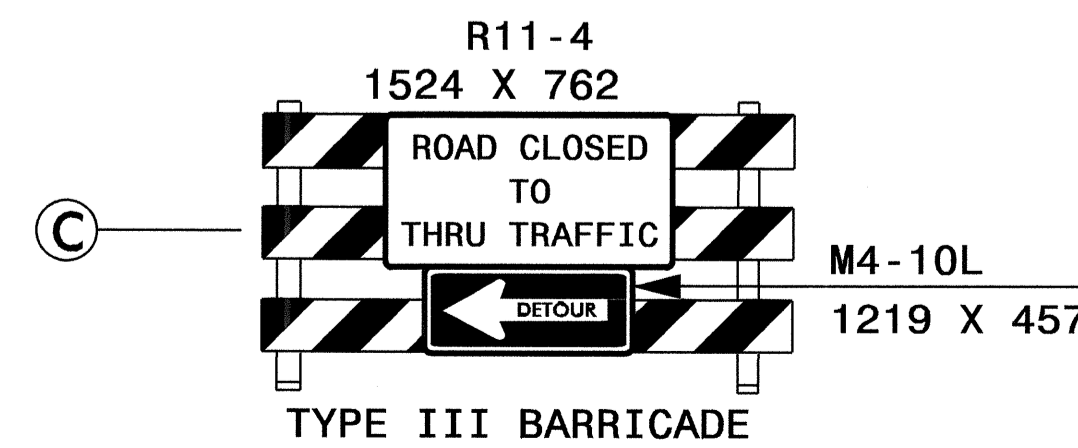
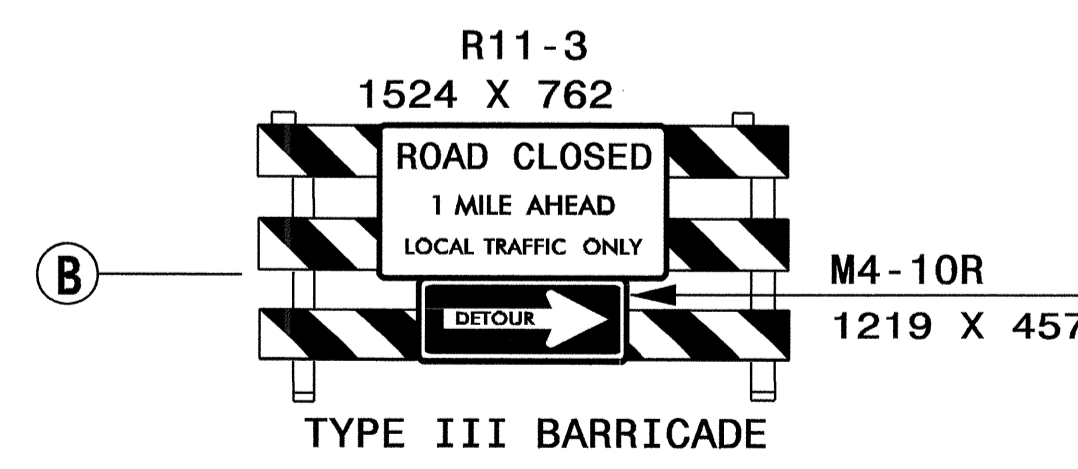
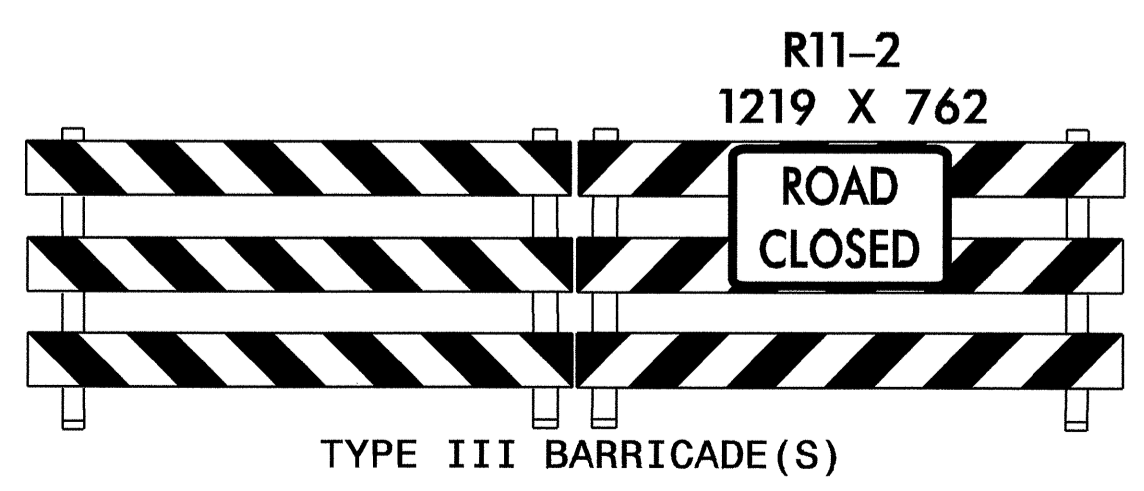
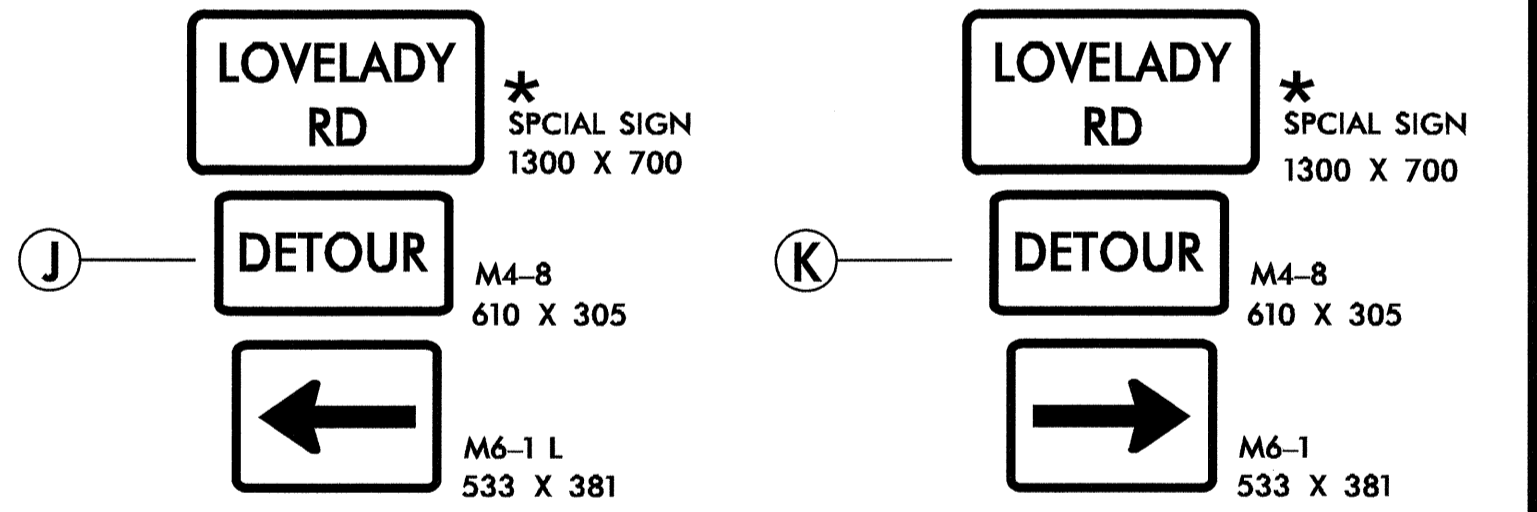
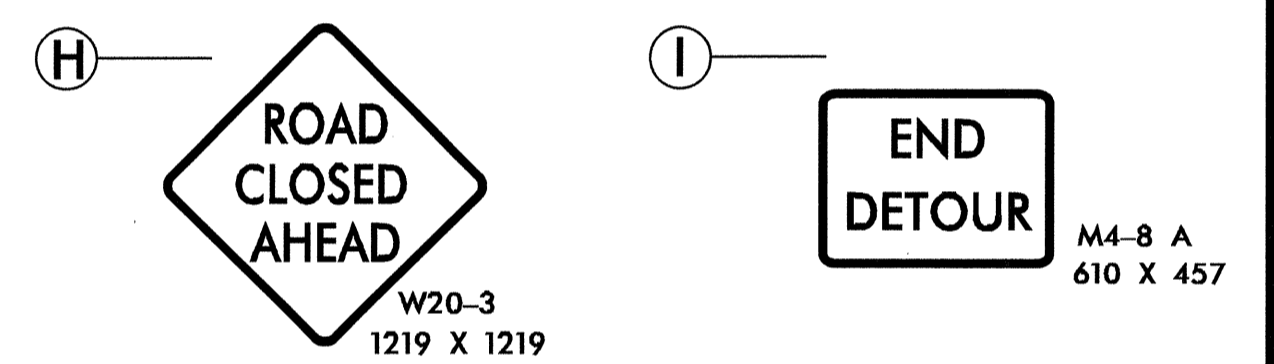
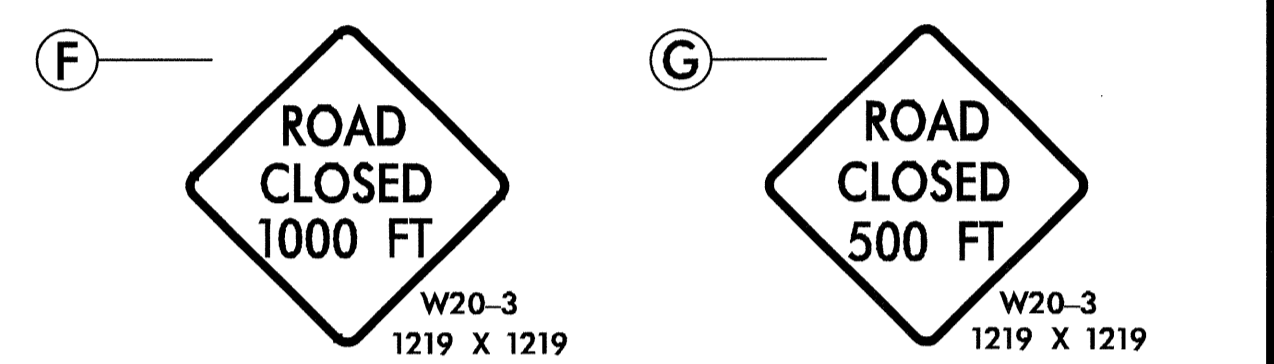
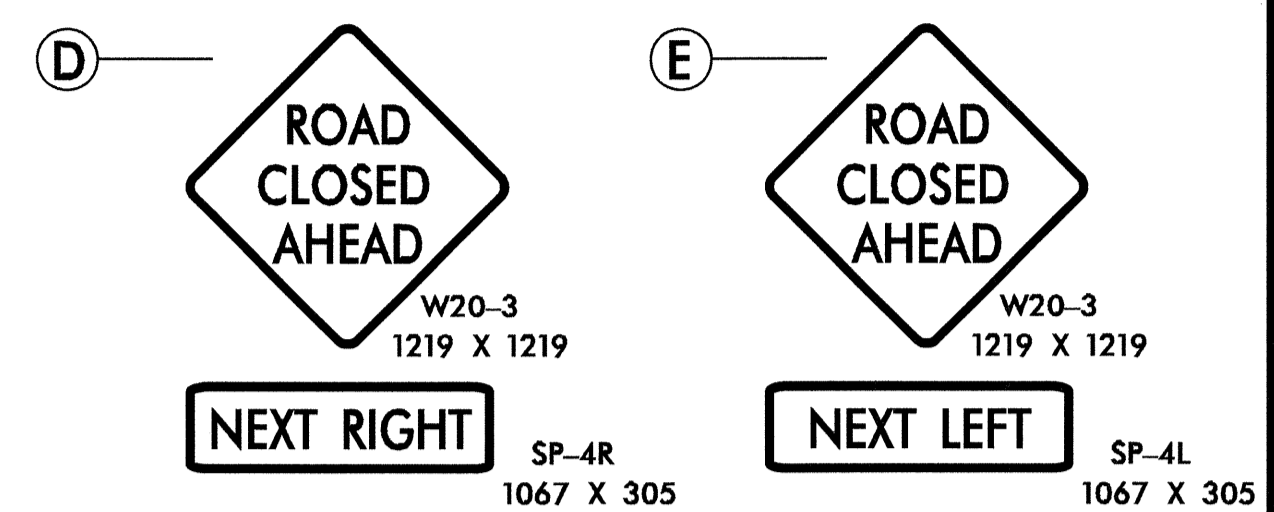

NOTE: SEE RSD 1101.03, SHEET 1 OF 9 FOR ADVANCE WARNING SIGNAGE AND BARRICADE PLACEMENT.

\* SEE SD-2 FOR SPECIAL SIGN DESIGN

02-MAR-2010 15:30 \\dot\dfsroot\01\NSP\Proj\TrafficControl\top\2824\_tcp16\_detour.dgn akp\atel AT WZTC244748

APPROVED:	DATE: 3/3/10	<b>- L - DETOUR ROUTE AND SIGNING</b>									
SCALE: NONE	DATE: 02/09	<table border="1"> <tr> <th colspan="2">REVISIONS</th> </tr> <tr> <td> </td> <td> </td> </tr> <tr> <td> </td> <td> </td> </tr> <tr> <td> </td> <td> </td> </tr> </table>		REVISIONS							
REVISIONS											
DWG. BY: AKP	DESIGN BY: AKP										
REVIEWED BY: DAP											

**TWO-WAY UNDIVIDED \*\* (L-LINE, SR-1546)**

PROJ. REFERENCE NO.	SHEET NO.
R-2824	TCP-17
BURKE	

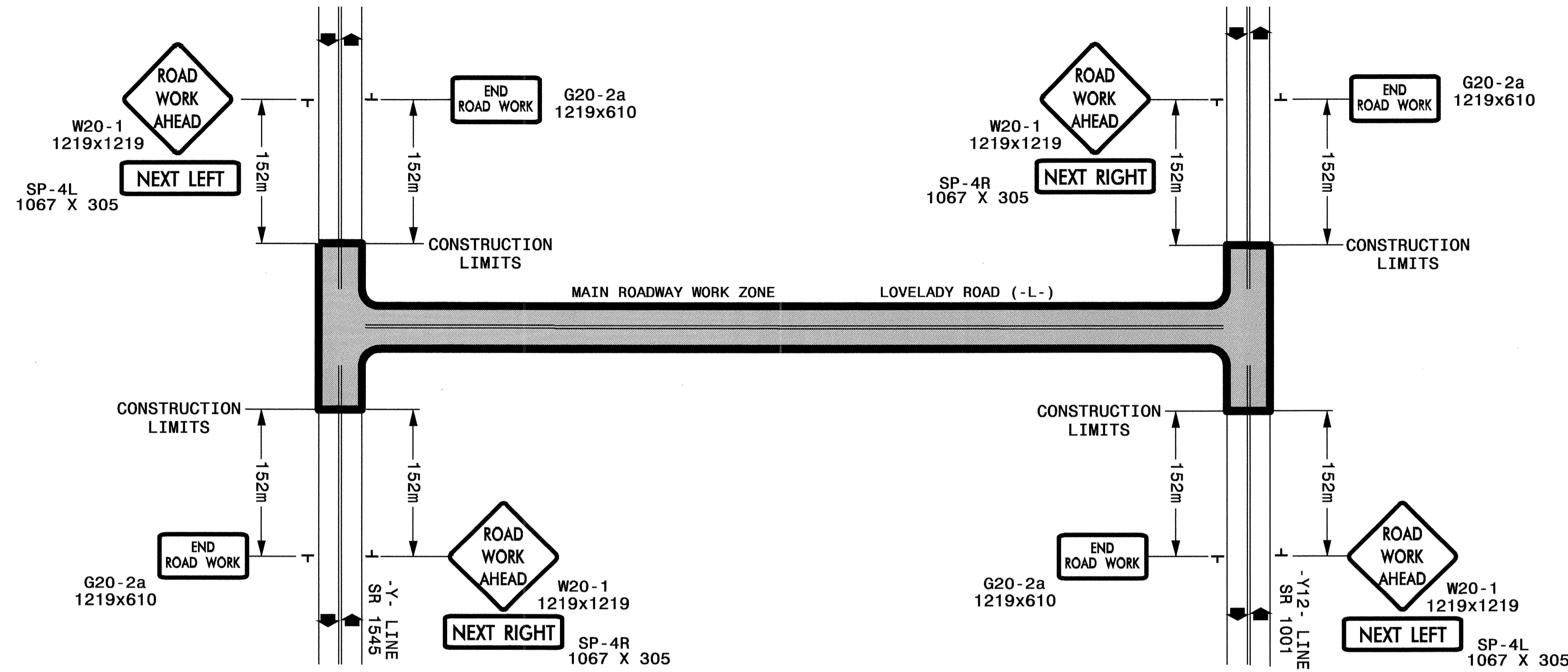

STATE OF NORTH CAROLINA  
DEPT. OF TRANSPORTATION  
DIVISION OF HIGHWAYS  
RALEIGH, N.C.

**ROADWAYS INTERSECTING ALONG 2 WAY UNDIVIDED WORK ZONE (-YA- LINE)**

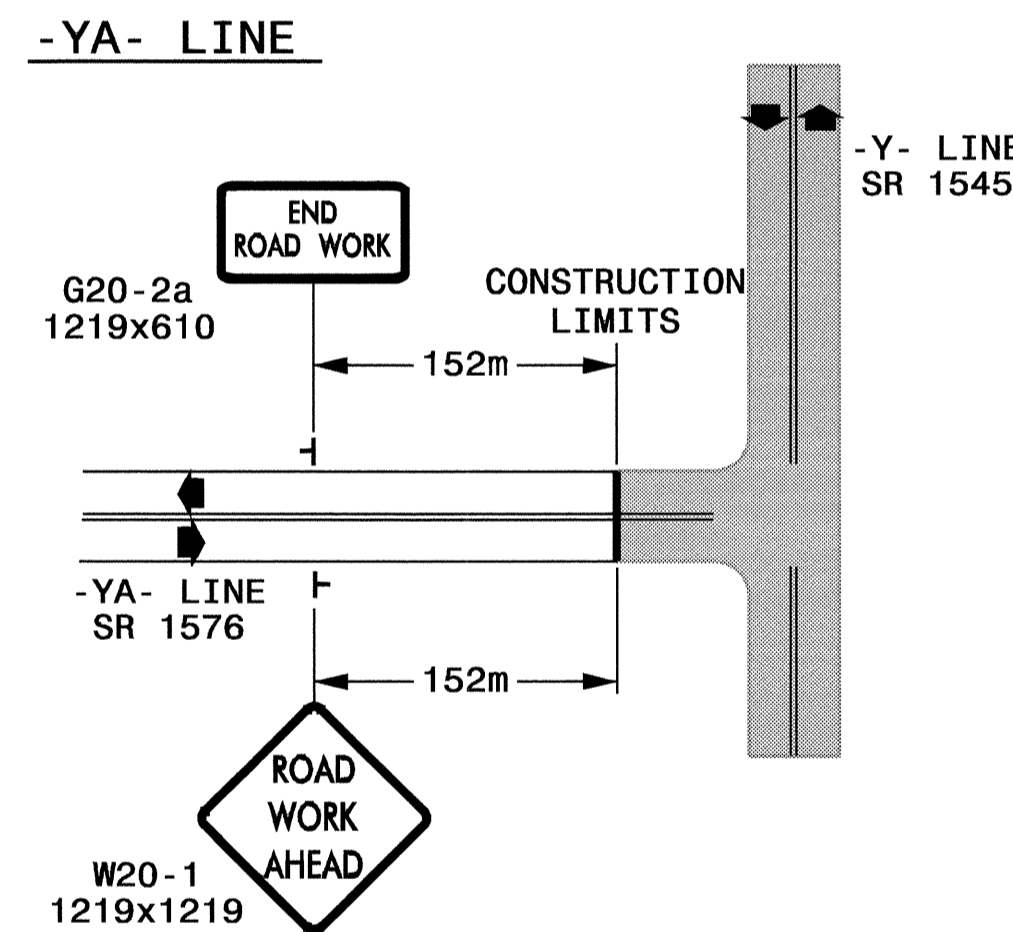

DETAIL DRAWING FOR  
TWO-WAY UNDIVIDED

**GENERAL NOTES**

- USE FLUORESCENT ORANGE SHEETING (TYPE VII OR HIGHER) ON ALL ADVANCED WORK ZONE SIGNS.
- DO NOT INSTALL ADVANCE WARNING SIGNS MORE THAN 3 DAYS PRIOR TO BEGINNING OF WORK.
- SIGNS SHOWN ARE REQUIRED FOR WORK ZONES THAT WILL REMAIN IN EFFECT OVERNIGHT. FOR SHORT-TERM DAILY MAINTENANCE TYPE OPERATIONS, THIS SIGNING APPLICATION IS OPTIONAL; MAY USE ONLY APPLICABLE ROADWAY STANDARD DRAWINGS INSTEAD. HOWEVER, IF THIS SIGNING APPLICATION IS USED, SIGNS MAY BE PORTABLE MOUNTED.
- ALL SIGN SPACING DIMENSIONS ARE APPROXIMATE, FIELD ADJUST AS NECESSARY OR AS DIRECTED.
- USE 1.4Kg STEEL U-CHANNEL POST OR 90mm X 90mm WOOD POST FOR ALL WORK ZONE SIGNS. 1.4Kg STEEL U-CHANNEL POSTS MUST MEET THE REQUIREMENTS OF STANDARD SPECIFICATION SECTION 1094-1(B), MAY BE GALVANIZED STEEL, OR MAY BE PAINTED GREEN BY THE POST MANUFACTURER. SQUARE STEEL TUBING POSTS HAVING EQUIVALENT STRENGTH OF THE 1.4Kg STEEL U-CHANNEL POST ARE ALSO ACCEPTABLE FOR USE. ERECT SIGNS PER ROADWAY STANDARD DRAWING 1110.01. PAYMENT FOR WOOD POSTS, 1.4Kg STEEL U-CHANNEL AND SQUARE STEEL TUBING POSTS WITH SIGNS WILL BE MADE ACCORDING TO STANDARD SPECIFICATION "WORK ZONE SIGNS" SECTION 1110.
- WHEN NECESSARY, USE SPLICING IN ACCORDANCE WITH ROADWAY STANDARD DRAWING NO. 1110.01. REMOVE ENTIRE POST WHEN REMOVING SIGNS WITH SPLICED POSTS.
- DO NOT BACK BRACE SIGN SUPPORTS.
- \*\* TWO-WAY UNDIVIDED ADVANCE WARNING SIGN CONFIGURATION MAY BE USED ON URBAN MULTI-LANE FACILITIES WHERE CONDITIONS LIMIT THE USE OF DUAL MOUNTED SIGNS AS DETERMINED BY THE ENGINEER.

**LEGEND**

- ┆ STATIONARY SIGN
- ◀ DIRECTION OF TRAFFIC FLOW

SHEET 1 OF 1

APPROVED:  DATE: 3/3/10	DETAIL DRAWING FOR TWO-WAY UNDIVIDED AND URBAN FREEWAYS ADVANCED WORK ZONE WARNING SIGNS	
	SCALE: NONE	REVISIONS
	DATE: 1/10	7-98 10/01
	DWG. BY: AKP	10-98 03/04
	DESIGN BY: AKP	01/01 11/04
REVIEWED BY: DAP		

02-MAR-2010 15:32 \\dot\dfsroot\0\NSProj\IPProj\Traffic\TrafficControl\cp\2824\_tcp\l\_wz\_signing.dgn