

TIP NO. R-2408B	SHEET NO. SIGN-1
APPROVED: <i>[Signature]</i>	
DATE: 2/4/10	
SEAL	

**STATE OF NORTH CAROLINA  
DEPARTMENT OF TRANSPORTATION**

**SIGNING PLANS**

**MACON COUNTY**

**LOCATION: NC 28 FROM NORTH OF SR 1323 (RIVERVIEW ST.)  
TO SOUTH OF SR 1378 (BENNETT RD)**

**MAP**

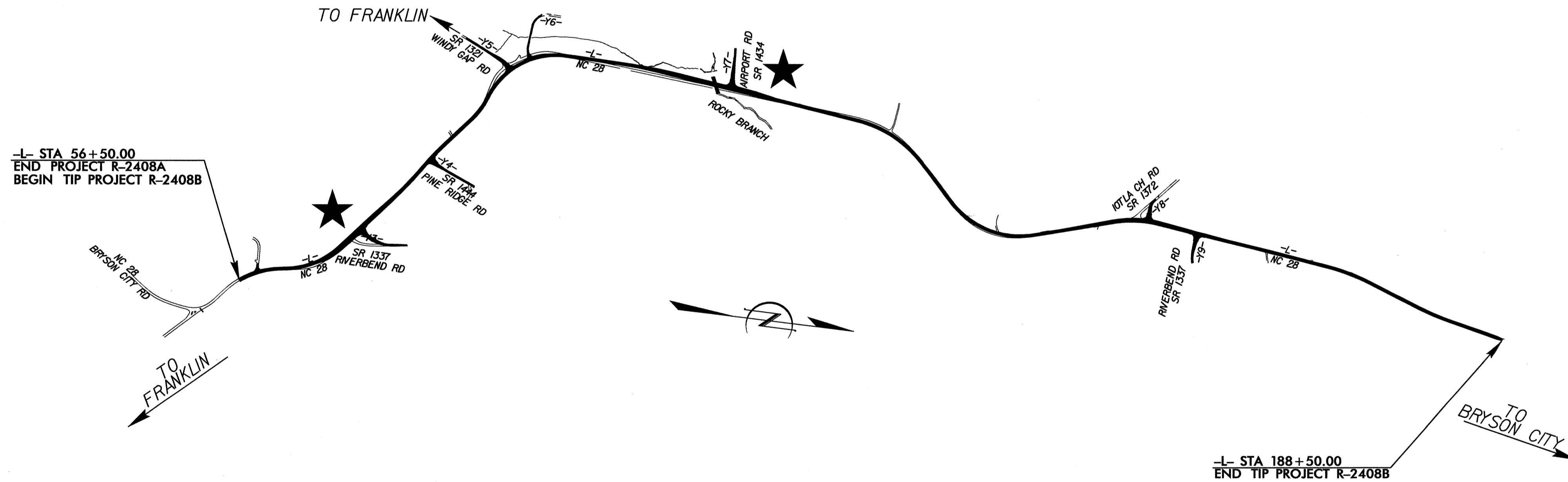

**INDEX**



SHEET NO.	DESCRIPTION
1	TITLE SHEET
2	SUMMARY OF QUANTITIES AND NOTES
3	E SHEET
4	F SHEET
5	SIGN DESIGNS
6-11	SIGN ROADWAY SHEETS

<b>PLAN PREPARED BY: N.C.D.O.T. SIGNING AND DELINEATION UNIT</b>	
<b>A. I. ALQUDWAH, P.E.</b>	SIGNING & DELINEATION REGIONAL ENGINEER
<b>J. G. MARTINEZ</b>	SIGNING & DELINEATION PROJECT DESIGN ENGINEER/TECHNICIAN

**T.I.P.: R-2408B**

**CONTRACT: C202240**

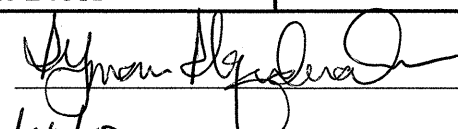
03-FEB-2010 15:23  
R:\Traffic\Signing\CADD\Signing Layout Plans\R-2408B\_Sgn\_Sheet.k11.dgn  
Jgmartinez

TIP NO. R-2408B	SHEET NO. SIGN-2
APPROVED: 	
DATE: 2/4/10	
SEAL	
	

## SIGNS SUMMARY OF QUANTITIES

ITEM NO.		ITEM DESCRIPTION	QUANTITY	UNIT
DESC. NO.	SECT. NO.			
4072000000	903	SUPPORTS, 3 LB STEEL U-CHANNEL .....	808	L.F.
4096000000	904	SIGN ERECTION, TYPE D .....	3	EA.
4102000000	904	SIGN ERECTION, TYPE E .....	38	EA.
4108000000	904	SIGN ERECTION, TYPE F .....	3	EA.
4116100000	904	SIGN ERECTION, RELOCATE SIGN TYPE D .....	2	EA.
4116100000	904	SIGN ERECTION, RELOCATE SIGN TYPE E .....	1	EA.
4155000000	907	DISPOSAL OF SIGN SYSTEM, U-CHANNEL .....	43	EA.

### General Notes:

- . SIGNS FURNISHED BY STATE
- . ALL TYPE 'D' SIGNS SHALL BE MOUNTED ON TWO U-CHANNEL POSTS UNLESS OTHERWISE INDICATED ON THE PLANS.
- . IF REMOVAL OR RELOCATION OF SIGNS ON PRIVATE STREET (NON-STATE MAINTAINED) IS REQUIRED DUE TO CONSTRUCTION, THE CONTRACTOR SHALL INFORM THE ENGINEER. THE WORK WILL BE COMPLETED BY OTHERS.
- . SIGNING PLANS DO NOT INCLUDE TEMPORARY CONSTRUCTION SIGNING OR PAVEMENT MARKINGS. SEE TRAFFIC CONTROL PLANS.
- . WHEN NOT STATIONED OR DIMENSIONED ON PLANS, ALL 'E' AND 'F' SIGNS SHALL BE FIELD LOCATED BY THE ENGINEER
- . ALL EXISTING SIGNS ON "U" CHANNEL POST WITHIN THE PROJECT LIMITS SHALL BE REMOVED AND DISPOSED OF UNLESS OTHERWISE NOTED ON PLANS.
- . WHEN EXISTING SIGNS ARE REMOVED AND INSTALLED ON NEW SUPPORTS, THE RE-ERECTION SHALL IMMEDIATELY FOLLOW THE REMOVAL.
- . THE BACKGROUND FOR TYPE E & F SIGNS SHALL BE TYPE C REFLECTIVE SHEETING.
- . SEE ROADWAY PLANS FOR GUARDGUIDE RAIL DETAILS.

### Project Notes:

### Pay Item Notes:

- |   |                                    |
|---|------------------------------------|
| 1 | DISPOSAL OF SIGN SYSTEM, U-CHANNEL |
| 2 | RELOCATE SIGN, TYPE D              |
| 3 | RELOCATE SIGN, TYPE E              |

**ROADWAY STANDARD DRAWINGS  
APPLICABLE TO THESE SIGNING PLANS**

901.50  
904.10  
904.50

**SUMMARY OF QUANTITIES  
AND NOTES**

APPROVED: *[Signature]*  
DATE: 2/9/10

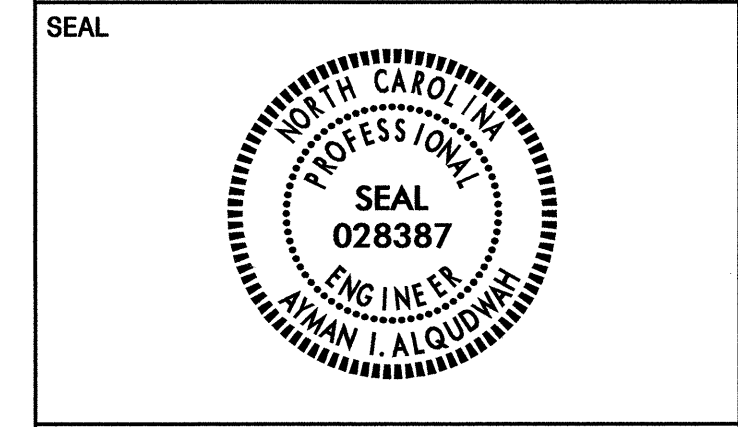

401 QUANTITY REQ'D 1

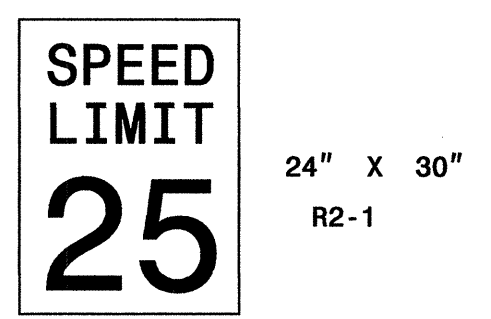

ONE "U" POST PER SIGN

406 QUANTITY REQ'D 1

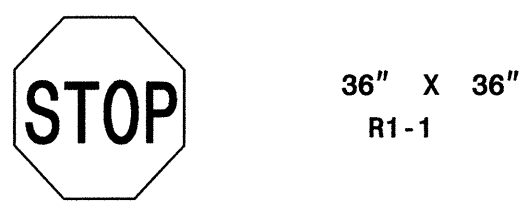

ONE "U" POST PER SIGN

411 QUANTITY REQ'D 1

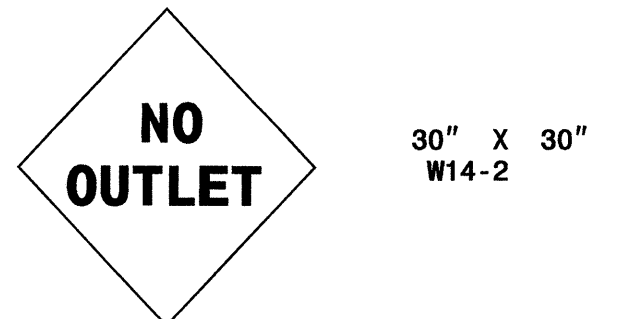

ONE "U" POST PER SIGN

402 QUANTITY REQ'D 5

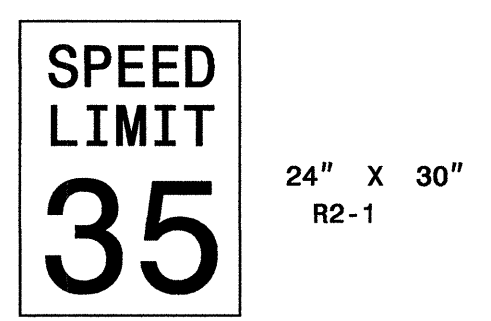

ONE "U" POST PER SIGN

407 QUANTITY REQ'D 2

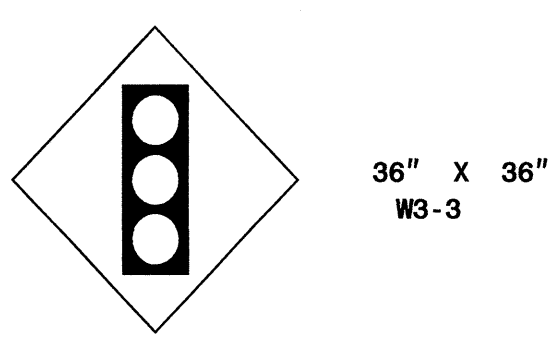

ONE "U" POST PER SIGN

412 QUANTITY REQ'D 4

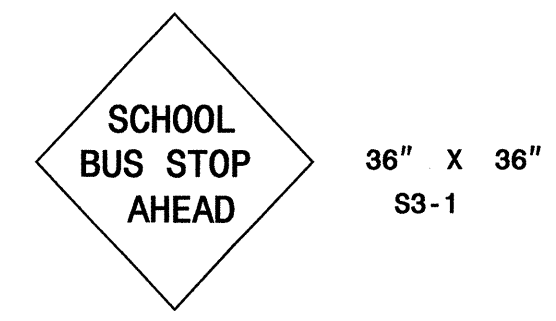

ONE "U" POST PER SIGN

403 QUANTITY REQ'D 4

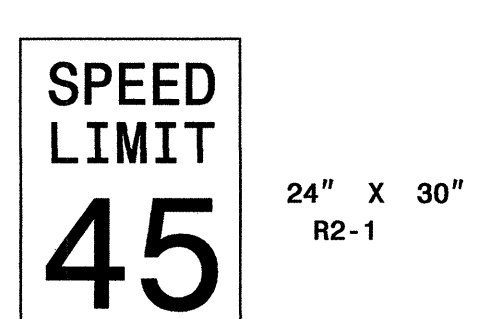

ONE "U" POST PER SIGN

408 QUANTITY REQ'D 6

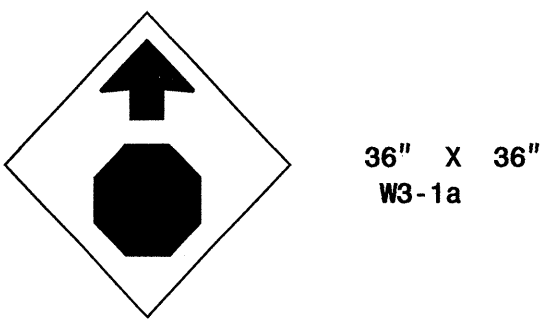

ONE "U" POST PER SIGN

413 QUANTITY REQ'D 2

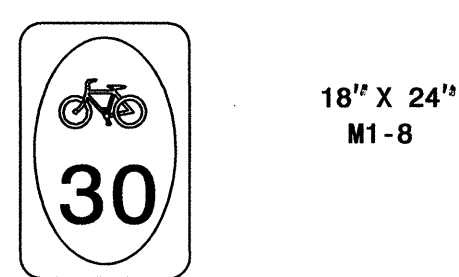

ONE "U" POST PER SIGN

404 QUANTITY REQ'D 1

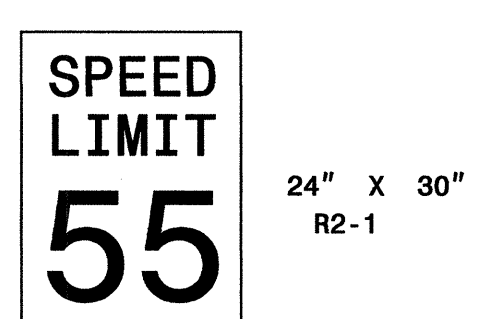

ONE "U" POST PER SIGN

409 QUANTITY REQ'D 2

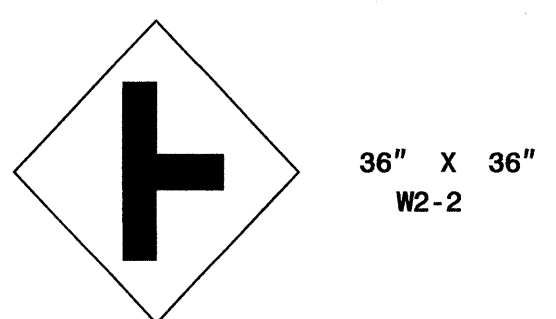

ONE "U" POST PER SIGN

414 QUANTITY REQ'D 2

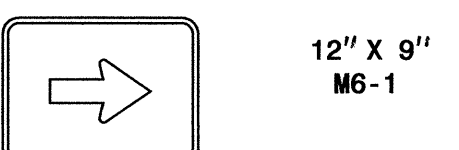

MOUNT BELOW SIGN 413  
IN 2 INSTALLATIONS

405 QUANTITY REQ'D 5



ONE "U" POST PER SIGN

410 QUANTITY REQ'D 1

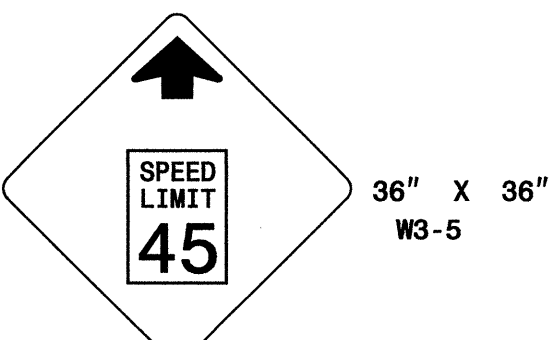

ONE "U" POST PER SIGN

419 QUANTITY REQ'D 1

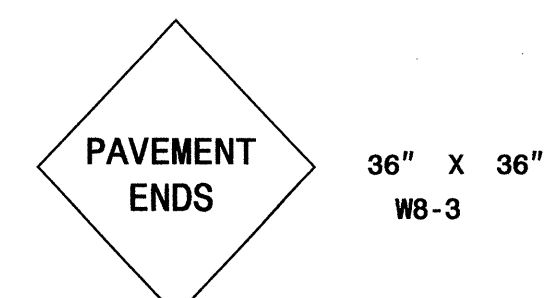

ONE "U" POST PER SIGN

**TYPE "E" SIGNS**

04-FEB-2010 14:39  
 R:\Traffic\Signing\CADD\Signing Layout Plans\AR-2408B.Sgn\_Sheet\_x11.dgn  
 Jgmartinez AT REC221650

TIP NO. R-24088	SHEET NO. SIGN-4
APPROVED: <i>[Signature]</i>	
DATE: 2/3/10	

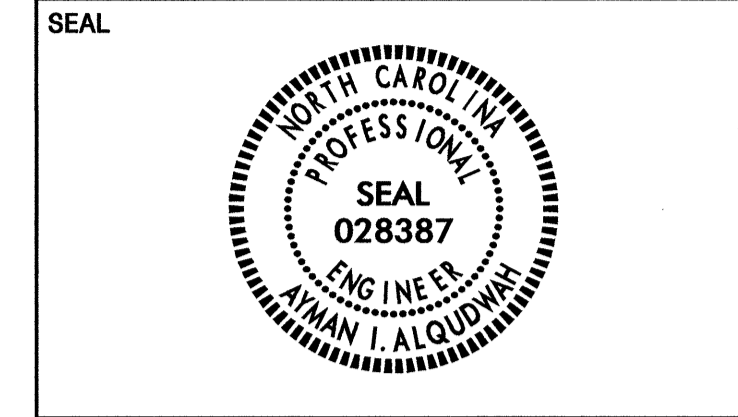

501

**NORTH**

24" X 12"

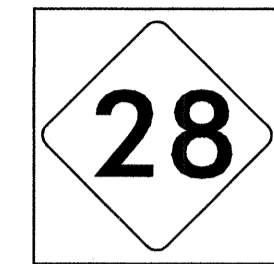

24" X 24"

502

503

**SOUTH**

24" X 12"

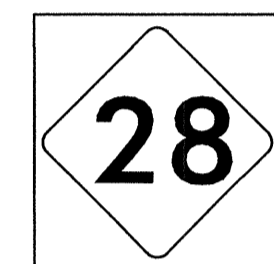

24" X 24"

03-FEB-2010 15:28  
 R:\Traffic\Signing\CADD\Signing Layout Plans\R-24088-Sgn-Sheet.x11.dgn  
 Jgmartinez

**TYPE "F" SIGNS**

WD 2/3/10



TIP NO. R-2408B	SHEET NO. SIGN-5
APPROVED: <i>[Signature]</i>	
DATE: 2/14/10	
SEAL	



SIGN NUMBER: 301	BACKG COLOR: Green	DESIGN BY: jgm	CHECKED BY:	DATE: Jan 28, 2010
TYPE: D	COPY COLOR: White	PROJECT ID: R-2408B	DIV: 14	

SYMBOL	X	Y	WID	HT
ARUP	5	19.3	6	9
ARUP	76	4.7	6	9

QUANTITY: 1  
SIGN WIDTH: 108"  
HEIGHT: 30"  
TOTAL AREA: 22.5 Sq.Ft.

BORDER TYPE: FLUSH  
RECESS: 0"  
WIDTH: 0.75"  
RADIUS: 3"

NO. Z BARS: MAT'L: 0.125" (3.2 mm) ALUMINUM  
LENGTH:

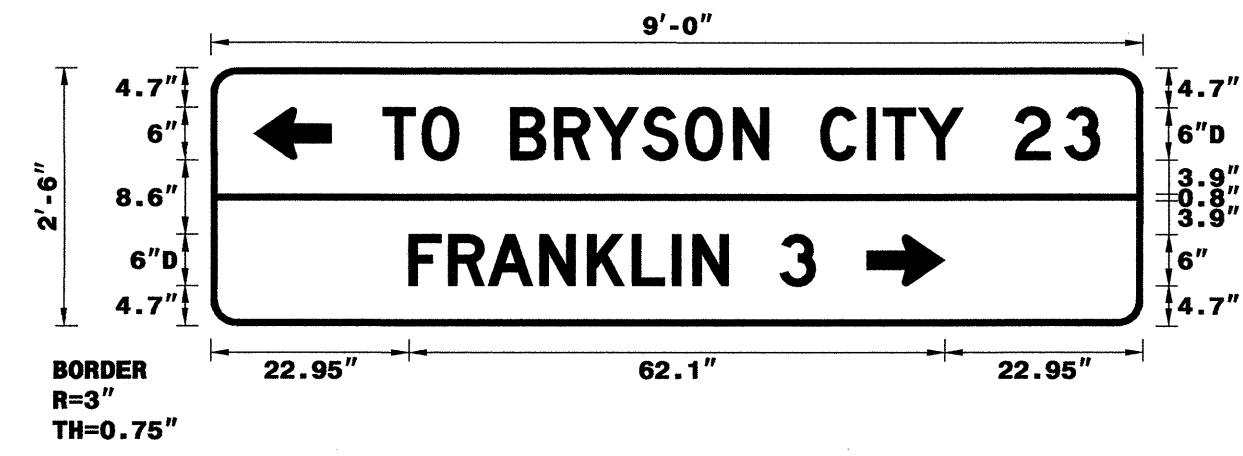

USE NOTES: 1,2

- Legend and border shall be direct applied Grade B sheeting.
- Background shall be Grade C reflective sheeting.
- Shields shall be on 0.032" (0.8mm) aluminum and demountable.
- Shields shall be Grade B sheeting.

Spacing Factor is 1 unless specified otherwise

LETTER POSITIONS

Letter spacings are to start of next letter																		Series/Size	
																		Text Length	
T	O	B	R	Y	S	O	N	C	I	T	Y	2	3					D 2000	
20	4.5	4.3	6	5.1	4.6	5.6	5	5.6	4.1	6	5.4	1.9	4.1	5.2	6	5.8	4.1	5	83
F	R	A	N	K	L	I	N	3										D 2000	
22.9	4.6	4.6	6	5.5	5.2	4.6	2.4	4.1	6	4.1	38							47.1	

FILENAME: R-2408B TC Sign Designs NORTH CAROLINA D.O.T. SIGN DETAIL

SIGN NUMBER: 303	BACKG COLOR: Blue/Green	DESIGN BY: jgm	CHECKED BY:	DATE: Jan 08, 2010
TYPE: D	COPY COLOR: White	PROJECT ID: R-2408B	DIV: 14	

SYMBOL	X	Y	WID	HT
ARUP	92	19.3	6	9
ARUP	78.7	4.7	6	9

QUANTITY: 1  
SIGN WIDTH: 108"  
HEIGHT: 30"  
TOTAL AREA: 22.5 Sq.Ft.

BORDER TYPE: FLUSH  
RECESS: 0"  
WIDTH: 0.75"  
RADIUS: 3"

NO. Z BARS: MAT'L: 0.125" (3.2 mm) ALUMINUM  
LENGTH:

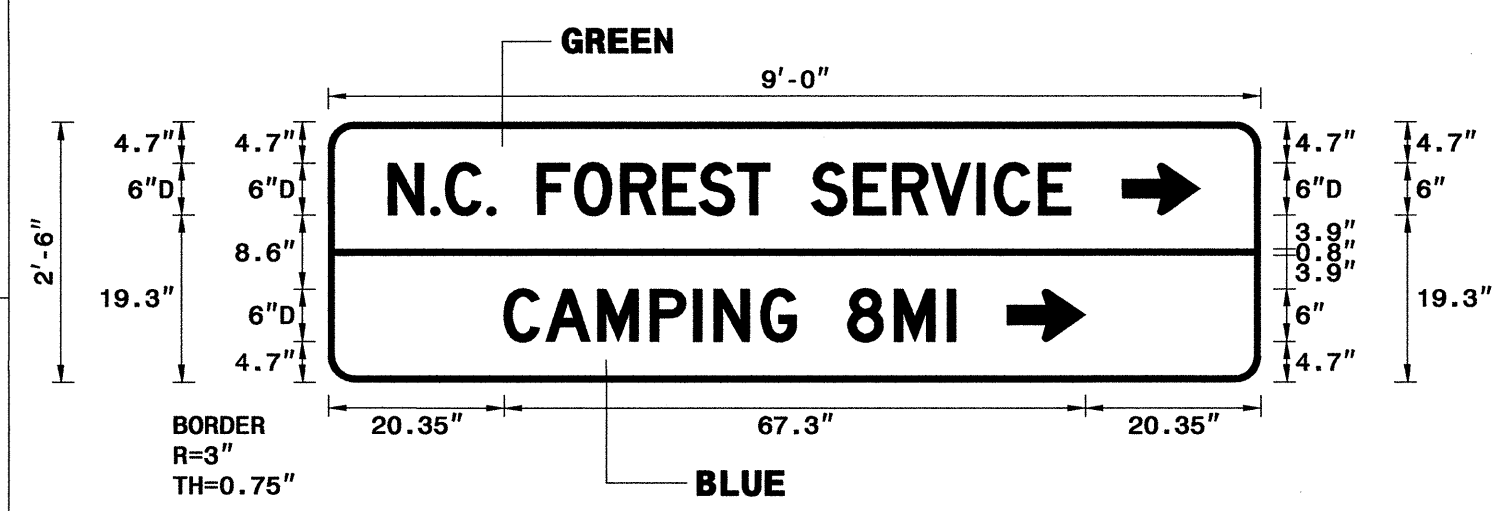

USE NOTES: 1,2

- Legend and border shall be direct applied Grade B sheeting.
- Background shall be Grade C reflective sheeting.
- Shields shall be on 0.032" (0.8mm) aluminum and demountable.
- Shields shall be Grade B sheeting.

Spacing Factor is 0.8 for first line of text.

LETTER POSITIONS

Letter spacings are to start of next letter																		Series/Size			
																		Text Length			
N	C	F	O	R	E	S	T	S	E	R	V	I	C	E				D 2000			
7	4.8	1.8	4.8	1.1	4.8	4.3	5.3	4.9	4.2	4.5	3.7	4.8	4.9	4.5	4.5	5.3	2	5.1	3.7	22	79
C	A	M	P	I	N	G	8	M	I										D 2000		
20.3	4.9	6	6.1	5	2.4	5.4	4.1	6	5.4	6.1	1	35.3							52.3		

FILENAME: R-2408B TC Sign Designs NORTH CAROLINA D.O.T. SIGN DETAIL

SIGN NUMBER: 302	BACKG COLOR: Blue/Green	DESIGN BY: jgm	CHECKED BY:	DATE: Jan 08, 2010
TYPE: D	COPY COLOR: White	PROJECT ID: R-2408B	DIV: 14	

SYMBOL	X	Y	WID	HT
ARUP	7	19.3	6	9
ARUP	20.3	4.7	6	9

QUANTITY: 1  
SIGN WIDTH: 108"  
HEIGHT: 30"  
TOTAL AREA: 22.5 Sq.Ft.

BORDER TYPE: FLUSH  
RECESS: 0"  
WIDTH: 0.75"  
RADIUS: 3"

NO. Z BARS: MAT'L: 0.125" (3.2 mm) ALUMINUM  
LENGTH:

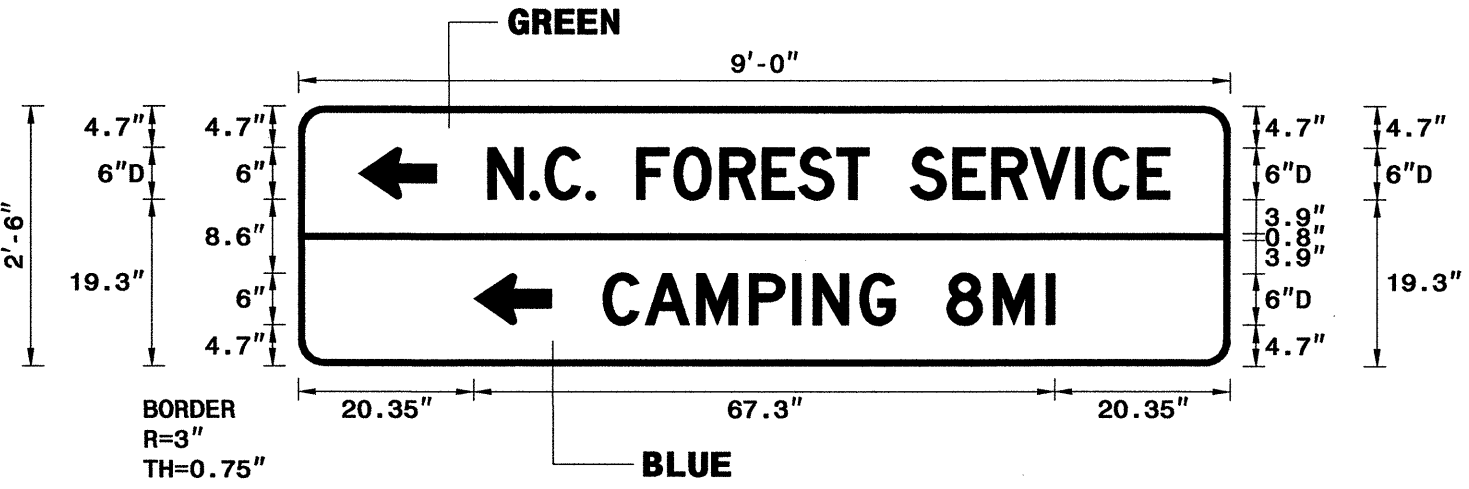

USE NOTES: 1,2

- Legend and border shall be direct applied Grade B sheeting.
- Background shall be Grade C reflective sheeting.
- Shields shall be on 0.032" (0.8mm) aluminum and demountable.
- Shields shall be Grade B sheeting.

Spacing Factor is 0.8 for first line of text.

LETTER POSITIONS

Letter spacings are to start of next letter																		Series/Size			
																		Text Length			
N	C	F	O	R	E	S	T	S	E	R	V	I	C	E				D 2000			
22	4.8	1.8	4.8	1.1	4.8	4.3	5.3	4.9	4.2	4.5	3.7	4.8	4.9	4.5	4.5	5.3	2	5.1	3.7	7	79
C	A	M	P	I	N	G	8	M	I										D 2000		
35.3	4.9	6	6.1	5	2.4	5.4	4.1	6	5.4	6.1	1	20.3							52.3		

FILENAME: R-2408B TC Sign Designs NORTH CAROLINA D.O.T. SIGN DETAIL

# SIGN DESIGNS

04-FEB-2010 14:37 R:\Triffco\Signing\CADD\Signing Layout Plans\R-2408B\_Sgn\_Sheet\_x11.dgn jgmartinez

TIP NO. R-2408B	SHEET NO. SIGN-6
APPROVED: <i>[Signature]</i>	
DATE: 2/4/10	
SEAL	

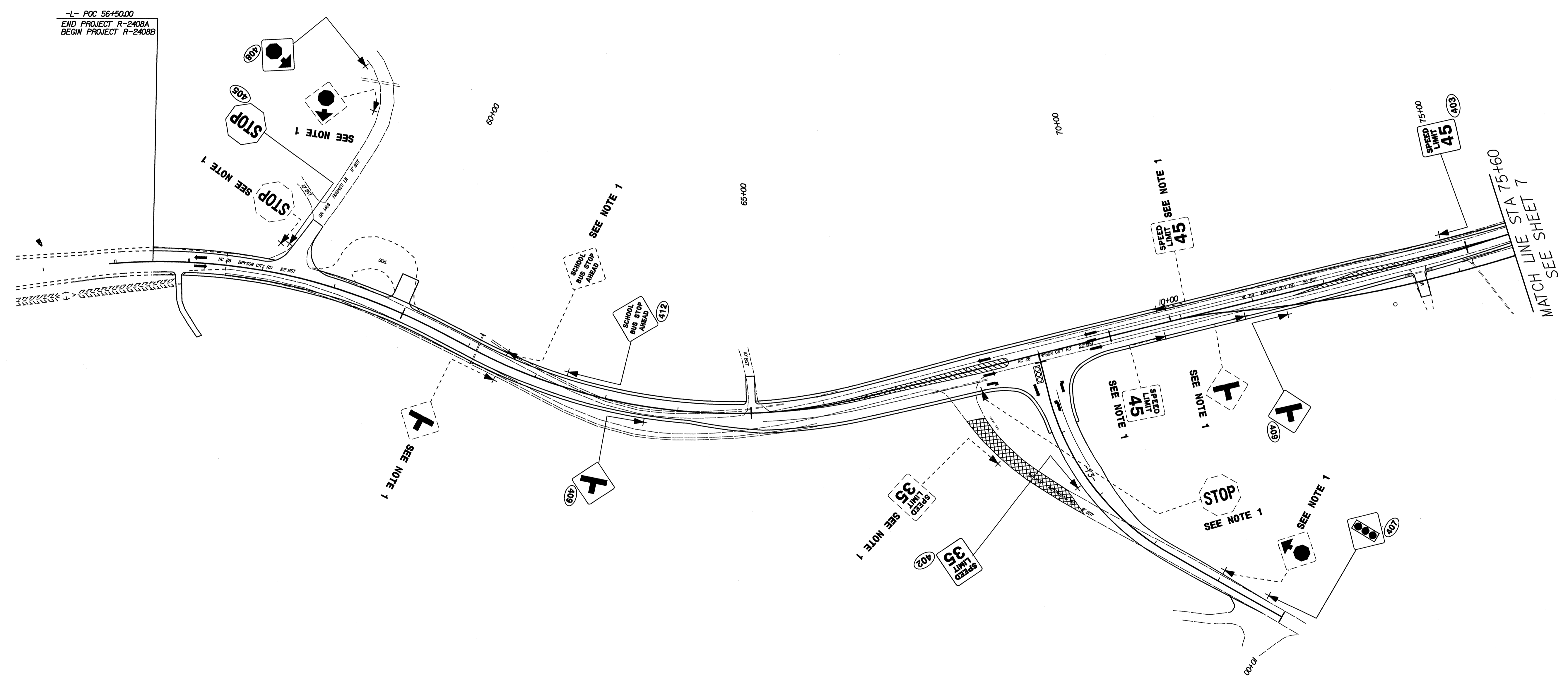

**NC28**  
**FROM STA 56+50 TO STA 75+60**

03-FEB-2010 14:21  
 R:\Traffic\Signing\CADD\Signing Layout Plans\R-2408B-Sgn\_Sheet\_v06.dgn  
 Jmartinez

3-WAY 1/2/10  
D/16

TIP NO. R-24088	SHEET NO. SIGN-7
APPROVED: <i>[Signature]</i>	
DATE: 2/14/10	
SEAL	



**NC28**  
**FROM STA 75+60 TO STA 97+00**

03-FEB-2010 14:22  
 R:\Traffic\Signing\CADD\Signing Layout Plans\R-24088.Sgn\_Sheet\_x07.dgn  
 Jmartinez AT REC221656

TIP NO. R-24088	SHEET NO. SIGN-8
APPROVED: <i>[Signature]</i>	
DATE: 2/4/10	
SEAL	

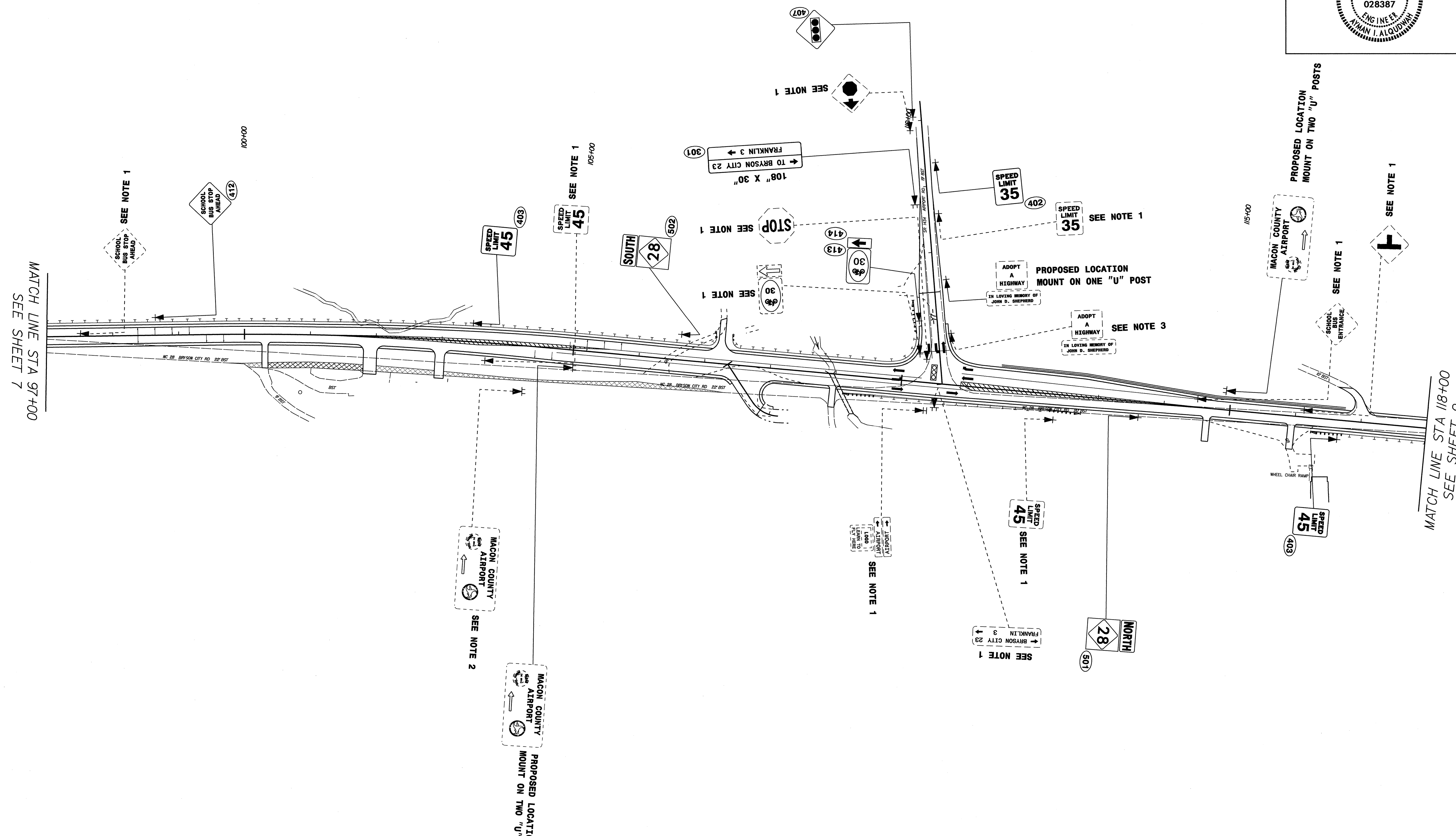

**NC28**  
**FROM STA 97+00 TO STA 118+00**

03-FEB-2010 14:23  
 R:\Traffic\Signing\CADD\Signing Layout Plans\R-24088-Sgn-Sheet.dgn  
 Jgmartinez

DME 1/2/10



TIP NO. R-2408B	SHEET NO. SIGN-9
APPROVED: <i>[Signature]</i>	
DATE: 2/4/10	
SEAL	

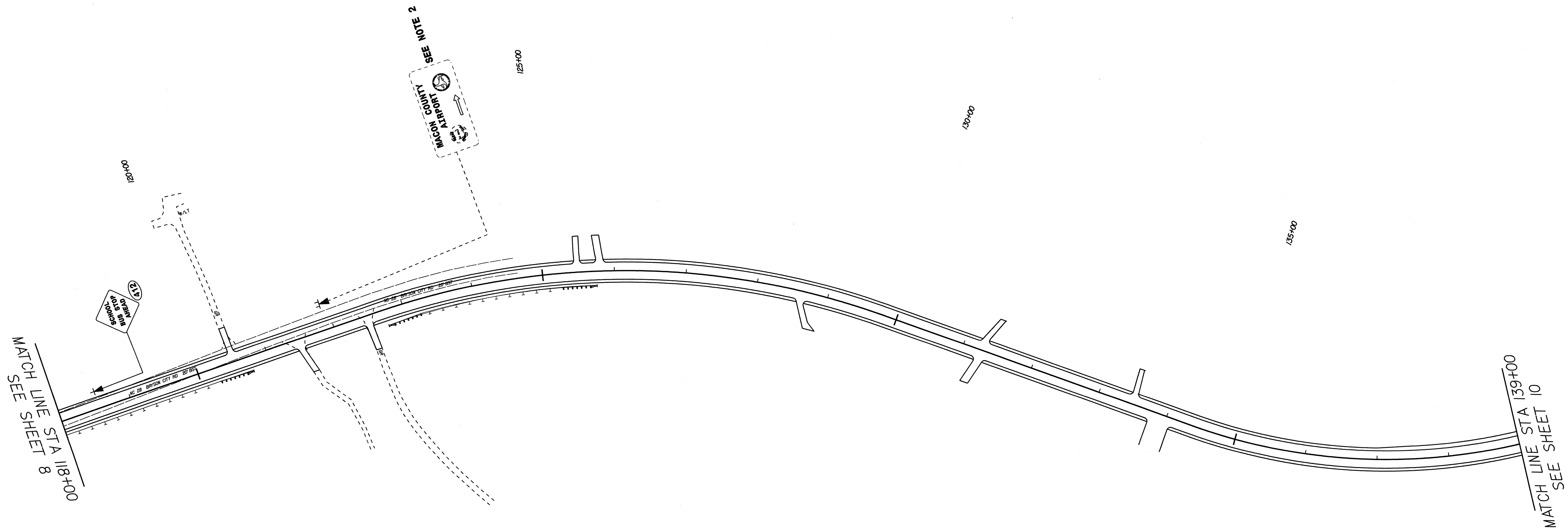
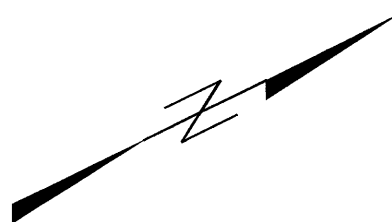

**NC28**  
**FROM STA 118+00 TO STA 139+00**

03-FEB-2010 14:23  
 R:\Traffic\Signing\CADD\Signing Layout Plans\R-2408B-Sgn-Sheet x09.dgn  
 Jmartinez AT REC221650

TIP NO. R-2408B	SHEET NO. SIGN-10
APPROVED: <i>[Signature]</i>	
DATE: 2/4/10	
SEAL	



SEAL  
028387  
ENGINEER  
ARIAN I. ALQUODWAH

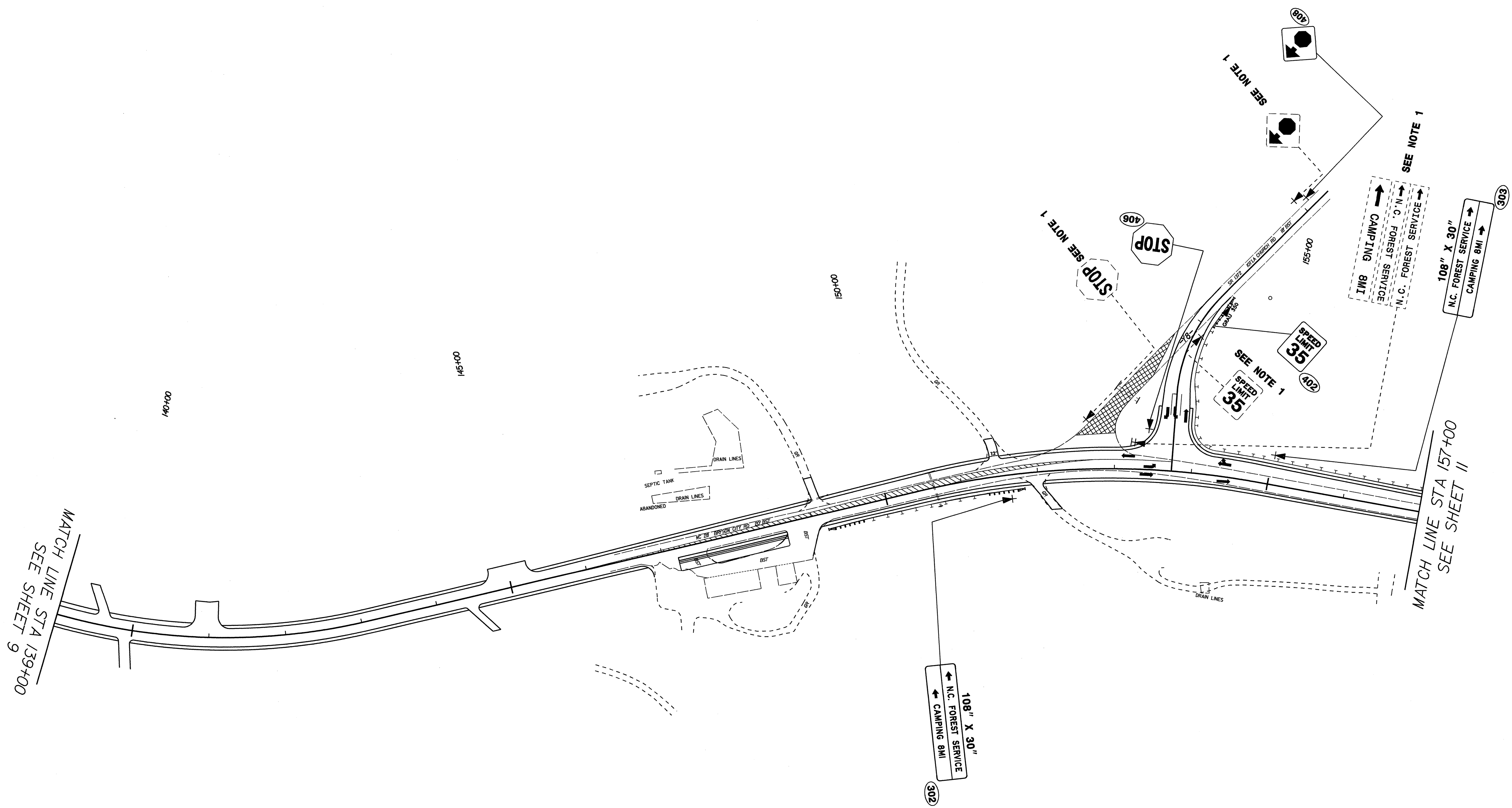

MATCH LINE STA 139+00  
SEE SHEET 9

MATCH LINE STA 157+00  
SEE SHEET 11

**NC28**  
**FROM STA 139+00 TO STA 157+00**

03-FEB-2010 14:24  
 R:\Traffic\Signing\CADD\Signing Layout Plans\R-2408B.Sgn\_Sheet x10.dgn  
 Jmartinez AT REC221650

TIP NO. R-2408B	SHEET NO. SIGN-11
APPROVED: <i>[Signature]</i>	
DATE: 2/4/10	
SEAL	

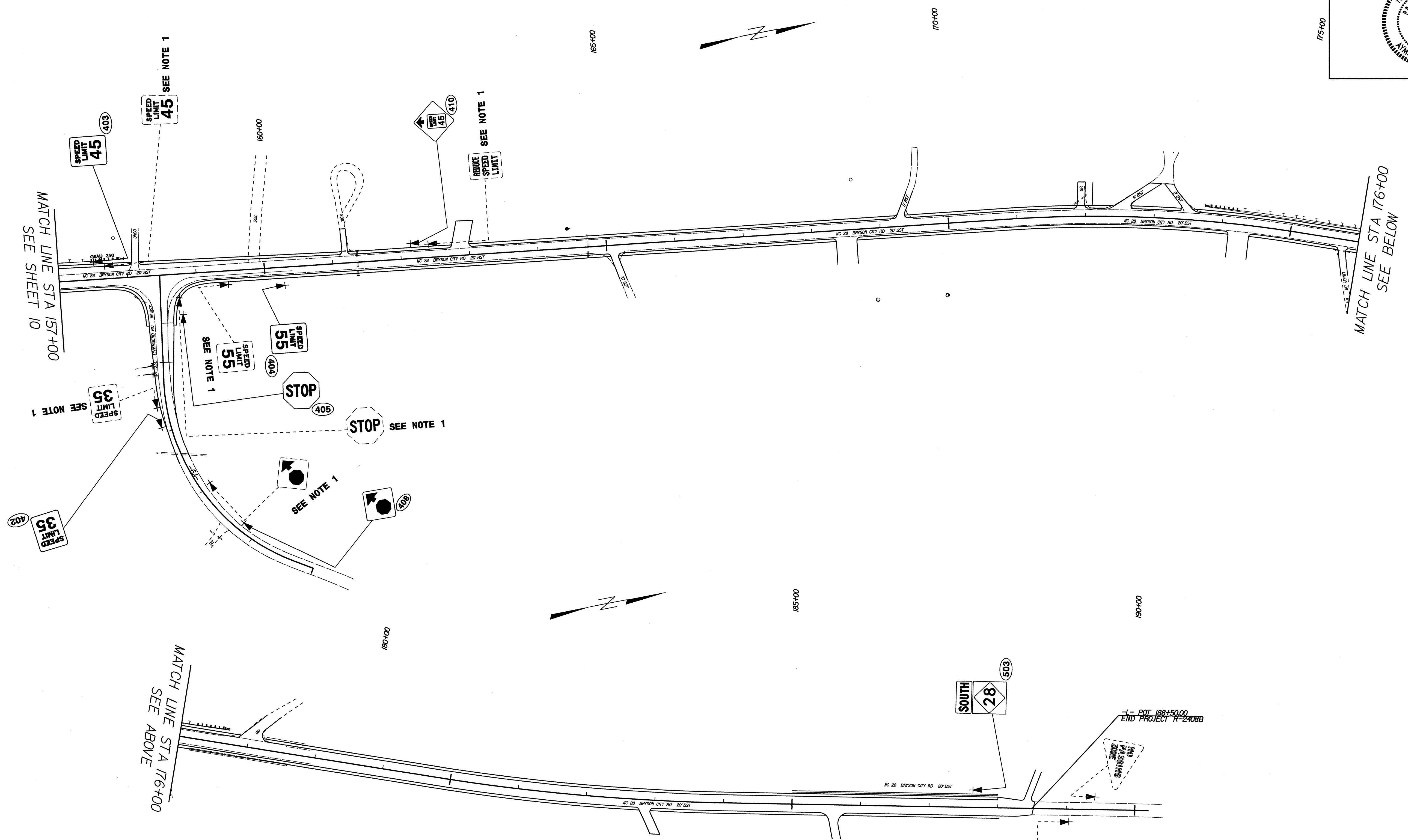

**NC28**  
**FROM STA 157+00 TO STA 190+00**

03-FEB-2010 14:25  
 R:\Traffic\Signing\Layout\Plans\R-2408B-Sgn-Sheet.x11.dgn  
 Jgmartinez AT REC221858