

## TEMPORARY PAVEMENT MARKING SCHEDULE

SYMBOL	DESCRIPTION	PAY ITEM/QUANTITY BREAKDOWN	TOTAL QUANTITY
<u>PAINT (4")</u>			
PA	WHITE EDGELINE	81,200 FT	
PB	YELLOW EDGELINE	3400 FT	
PC	10 FT WHITE SKIP	16,700 FT	
PD	2 FT WHITE MINI SKIP	5500 FT	
PE	WHITE LANE LINE	34,000 FT	
PF	10 FT YELLOW SKIP	220 FT	
PH	YELLOW SINGLE CENTER LINE	880 FT	
PI	YELLOW DOUBLE CENTER LINE	219,000 FT	TOTAL 334,200 FT
<u>PAINT (8")</u>			
PR	WHITE GORE LINE	6660 FT	
PS	WHITE DIAGONAL	500 FT	
PV	YELLOW DIAGONAL	440 FT	
PX	WHITE CROSSWALK	6200 FT	TOTAL 13,800 FT
<u>PAINT (24")</u>			
P4	WHITE STOP BAR	3200 FT	TOTAL 3200 FT
<u>PAINT SYMBOLS</u>			
QA	LEFT TURN ARROW	300 EA	
QB	RIGHT TURN ARROW	100 EA	
QC	STRAIGHT ARROW	126 EA	
QD	COMBO STRAIGHT/LEFT ARROW	6 EA	
QE	COMBO STRAIGHT/RIGHT ARROW	13 EA	TOTAL 545 EA
<u>PAINT CHARACTERS</u>			
QI	ALPHA NUMERIC CHARACTER	8 EA	TOTAL 8 EA
<u>TEMPORARY RAISED MARKERS</u>			
MH	YELLOW/YELLOW	1985 EA	
MI	CRYSTAL/RED	1318 EA	TOTAL 3303 EA

## FINAL PAVEMENT MARKING SCHEDULE

SYMBOL	DESCRIPTION	PAY ITEM/QUANTITY BREAKDOWN	TOTAL QUANTITY
<u>THERMOPLASTIC (4", 90 MILS)</u>			
TA	WHITE EDGELINE	13,700 FT	
TB	YELLOW EDGELINE	1700 FT	TOTAL 15,400 FT
<u>THERMOPLASTIC (4", 120 MILS)</u>			
TC	10 FT WHITE SKIP	7300 FT	
TD	2 FT WHITE MINI SKIP	1550 FT	
TE	WHITE LANE LINE	10,000 FT	
TF	10 FT YELLOW SKIP	120 FT	
TH	YELLOW SINGLE CENTER LINE	450 FT	
TI	YELLOW DOUBLE CENTER LINE	15,200 FT	TOTAL 34,620 FT
<u>THERMOPLASTIC (8", 90 MILS)</u>			
TP	WHITE GORE LINE	3330 FT	
TQ	WHITE DIAGONAL	250 FT	
TT	YELLOW DIAGONAL	220 FT	TOTAL 3800 FT
<u>THERMOPLASTIC (8", 120 MILS)</u>			
TV	WHITE CROSSWALK	3100 FT	TOTAL 3100 FT
<u>THERMOPLASTIC (24", 120 MILS)</u>			
T2	WHITE STOP BAR	800 FT	TOTAL 800 FT
<u>THERMOPLASTIC SYMBOLS (90 MILS)</u>			
UA	LEFT TURN ARROW	120 EA	
UB	RIGHT TURN ARROW	80 EA	
UC	STRAIGHT ARROW	100 EA	
UD	COMBO STRAIGHT/LEFT ARROW	5 EA	
UE	COMBO STRAIGHT/RIGHT ARROW	10 EA	TOTAL 315 EA
<u>THERMOPLASTIC CHARACTERS (120 MILS)</u>			
UI	ALPHA NUMERIC CHARACTER	8 EA	TOTAL 8 EA
<u>SNOWPLOWABLE RAISED MARKERS</u>			
ME	YELLOW/YELLOW	805 EA	
MF	CRYSTAL/RED	430 EA	TOTAL 1235 EA

I5-JAN-2010 12:25  
 C:\Users\jacob\Documents\Projects-R\4430\TrafficControl\Tcd\DRs PM-1-4430-fc-dmp-01.dgn  
 AT: WZTC237460  
 des: rch: gsb:

APPROVED:  DATE: 1/19/2010	<b>TEMPORARY PAVEMENT MARKING SCHEDULE AND FINAL PAVEMENT MARKING SCHEDULE</b>					
	SCALE: NONE DATE: JUL-08 DWG. BY: DESIGN BY: REVIEWED BY:	<table border="1" style="width: 100%; border-collapse: collapse;"> <tr> <th style="text-align: center;">REVISIONS</th> </tr> <tr> <td style="height: 20px;"> </td> </tr> <tr> <td style="height: 20px;"> </td> </tr> <tr> <td style="height: 20px;"> </td> </tr> </table>	REVISIONS			
REVISIONS						

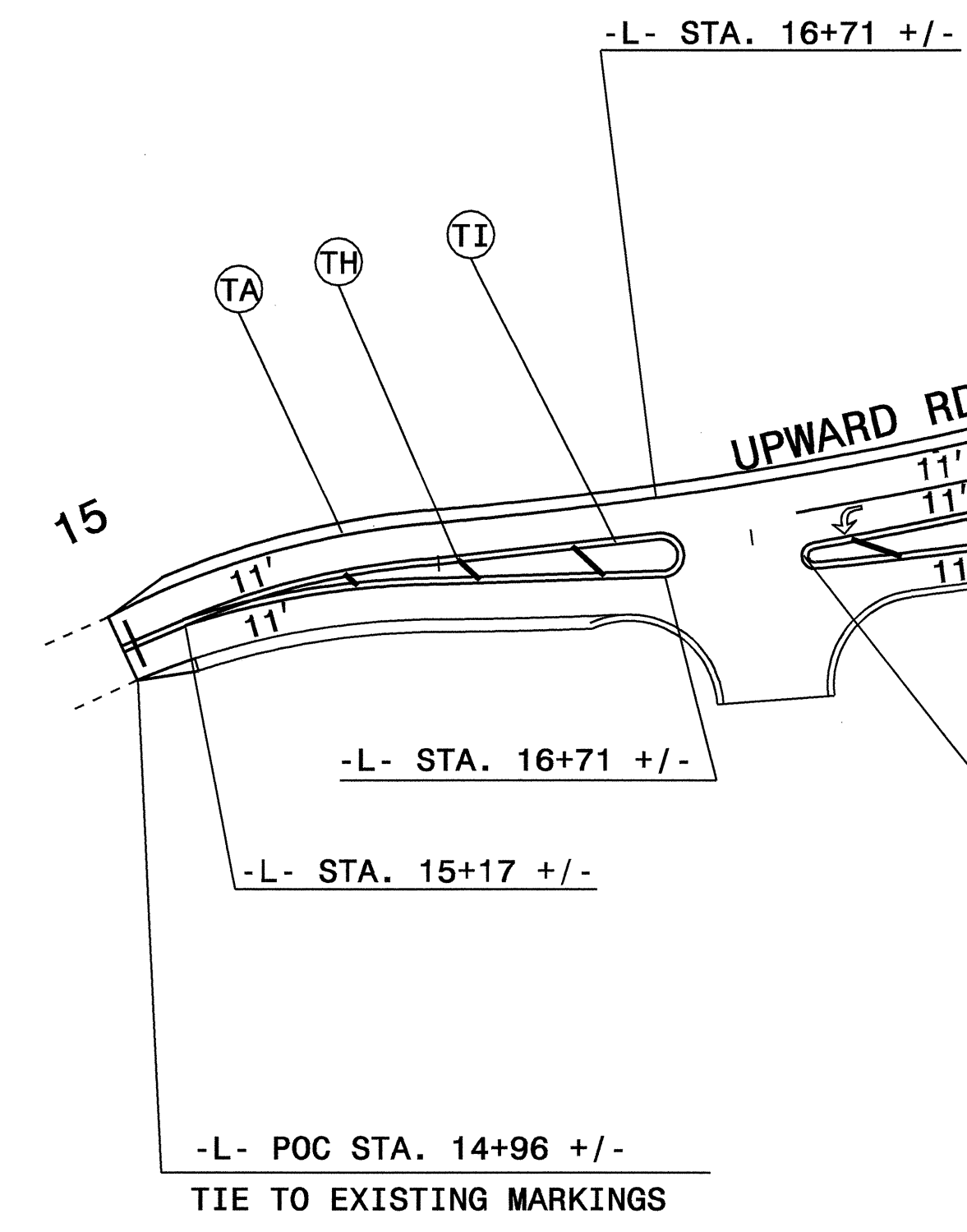
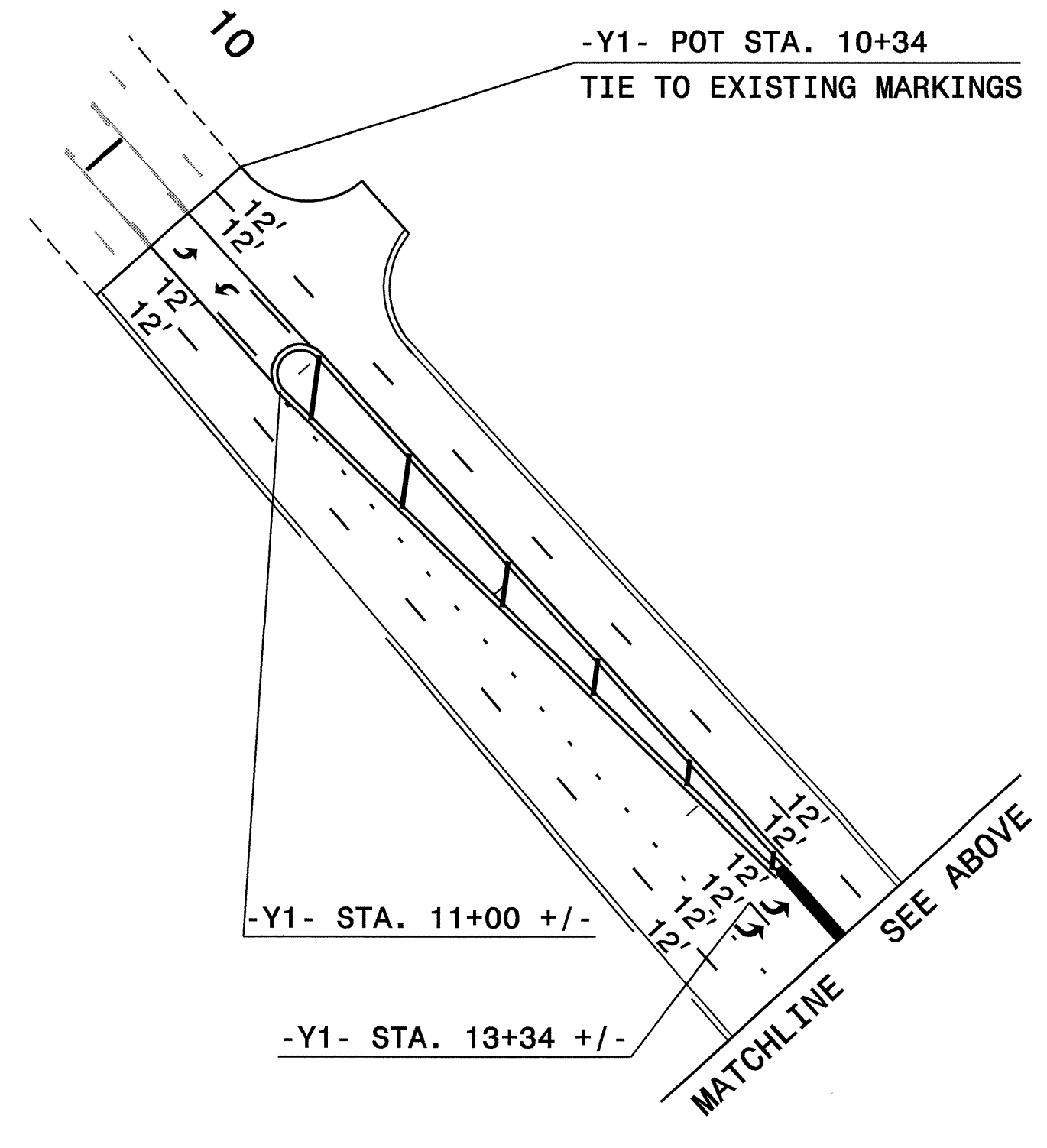
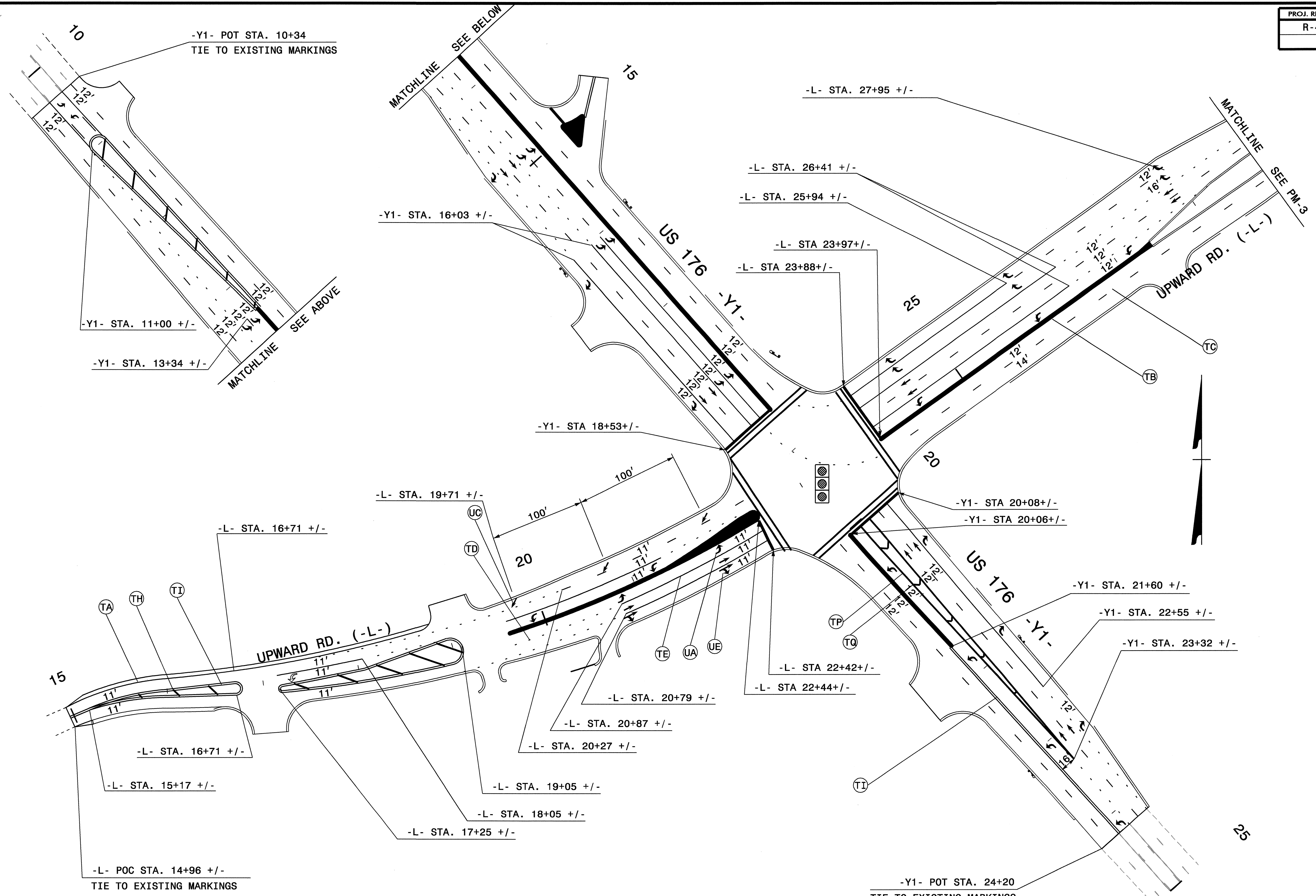

NOTE: STANDARD SPACING FOR SYMBOLS AT SIGNALIZED INTERSECTIONS PLACES THE FIRST SET OF SYMBOLS AT 60' FROM THE STOPBAR AND THE REMAINING AS SHOWN ON THE PLANS.

NOTE: ALL CROSSWALKS ARE TO BE A MINIMUM OF 4' FROM STOPBARS AND A WIDTH OF 6' WITH 8" LINES.

APPROVED: *[Signature]* DATE: 10/20/09

SEAL: 

### PAVEMENT MARKING

SCALE:	NONE		<table border="1"> <tr><th colspan="2">REVISIONS</th></tr> <tr><td> </td><td> </td></tr> <tr><td> </td><td> </td></tr> <tr><td> </td><td> </td></tr> </table>	REVISIONS							
REVISIONS											
DATE:	JUL - 08										
DWG. BY:	DR										
DESIGN BY:	DR										
REVIEWED BY:	DAP	CADD FILE									

30-OCT-2009 14:02  
 \\dot\dfsroot\01\Projects\TrafficControl\p\4430\TrafficControl\p\4430\pm\pm-2.dgn  
 derichardson AT WZ1237460

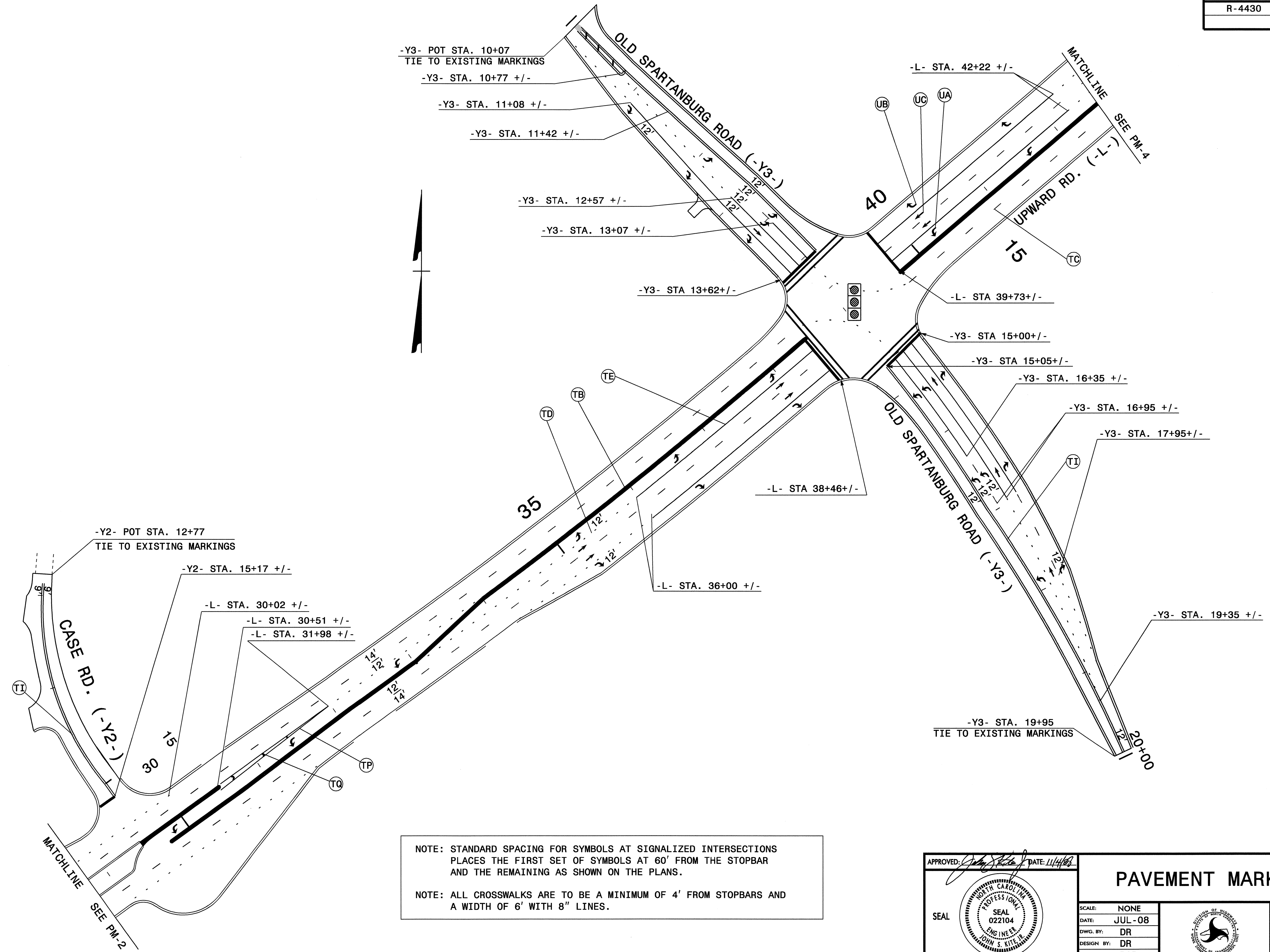

NOTE: STANDARD SPACING FOR SYMBOLS AT SIGNALIZED INTERSECTIONS PLACES THE FIRST SET OF SYMBOLS AT 60' FROM THE STOPBAR AND THE REMAINING AS SHOWN ON THE PLANS.

NOTE: ALL CROSSWALKS ARE TO BE A MINIMUM OF 4' FROM STOPBARS AND A WIDTH OF 6' WITH 8" LINES.

APPROVED: <i>[Signature]</i> DATE: 11/4/08	<b>PAVEMENT MARKING</b>									
SCALE: NONE	DATE: JUL-08	<table border="1"> <tr> <th colspan="2">REVISIONS</th> </tr> <tr> <td> </td> <td> </td> </tr> <tr> <td> </td> <td> </td> </tr> <tr> <td> </td> <td> </td> </tr> </table>	REVISIONS							
REVISIONS										
DWG. BY: DR	DESIGN BY: DR									
REVIEWED BY: DAP										

04-NOV-2008 17:43  
 \\dot\dfsroot\01\Projects-R-4430\trafficcontrol\top\dr\pm\Y-4430.tc.pmp\_03.dgn  
 AT WZTC237460  
 derfahardson

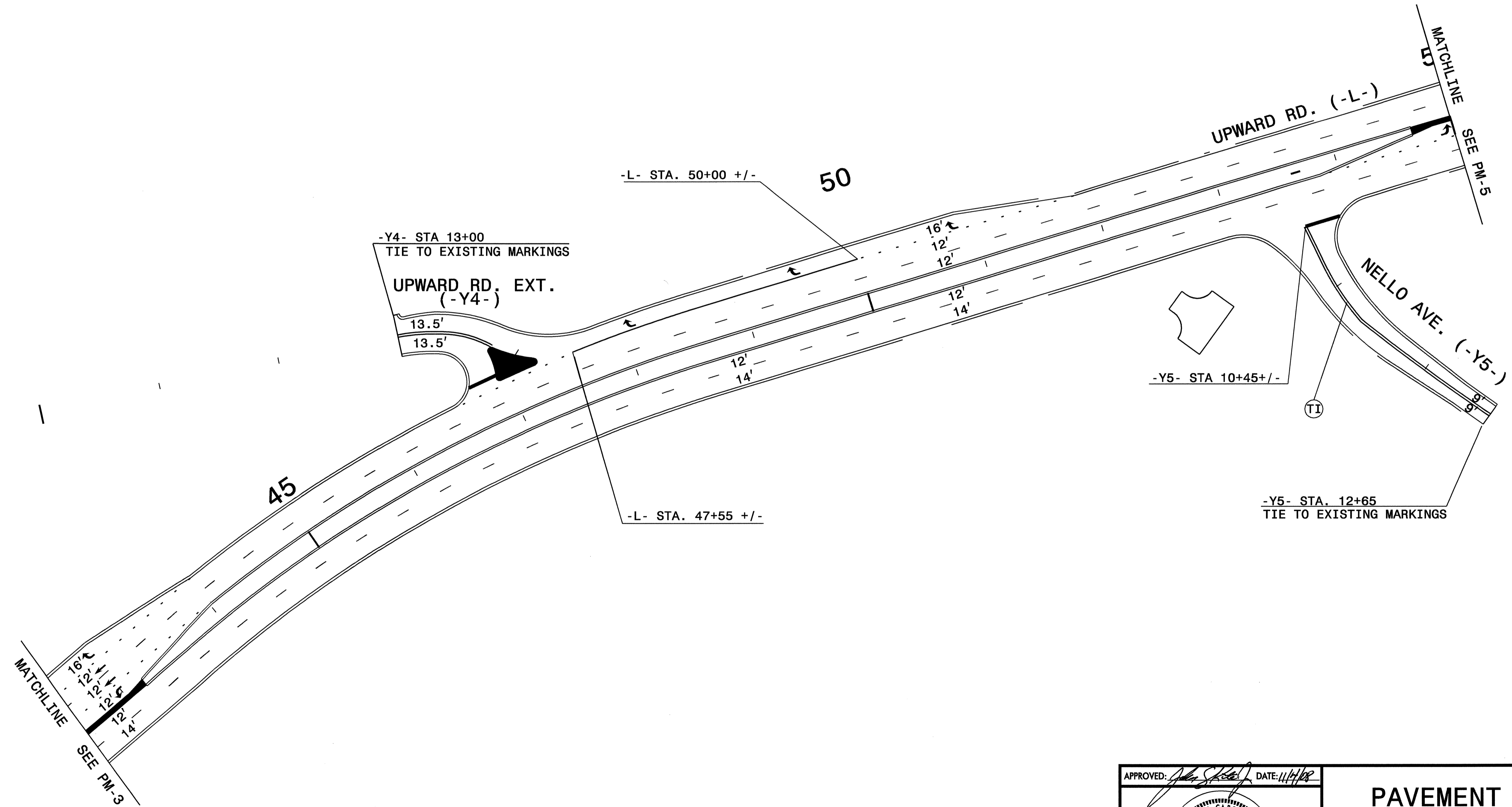
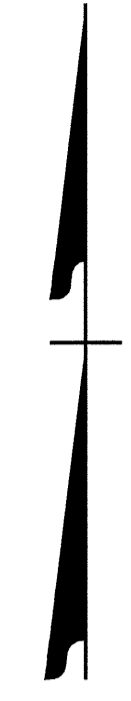

03-NOV-2008 12:04  
 \\dot\dfsroot\01\p\projects-r\4430\traffic\trafficcontrol\top\drs pm\4430.tc.pmp.04.dgn  
 AT WZTC237460  
 derichardson

APPROVED: <i>[Signature]</i> DATE: 11/4/08		<b>PAVEMENT MARKING</b>																	
SEAL				<table border="1"> <tr> <td>SCALE:</td> <td>NONE</td> <td rowspan="4" style="text-align: center;"> </td> <td>REVISIONS</td> </tr> <tr> <td>DATE:</td> <td>JUL - 08</td> <td></td> </tr> <tr> <td>DWG. BY:</td> <td>DR</td> <td></td> </tr> <tr> <td>DESIGN BY:</td> <td>DR</td> <td></td> </tr> <tr> <td>REVIEWED BY:</td> <td>DAP</td> <td></td> <td></td> </tr> </table>	SCALE:	NONE		REVISIONS	DATE:	JUL - 08		DWG. BY:	DR		DESIGN BY:	DR		REVIEWED BY:	DAP
SCALE:	NONE		REVISIONS																
DATE:	JUL - 08																		
DWG. BY:	DR																		
DESIGN BY:	DR																		
REVIEWED BY:	DAP																		

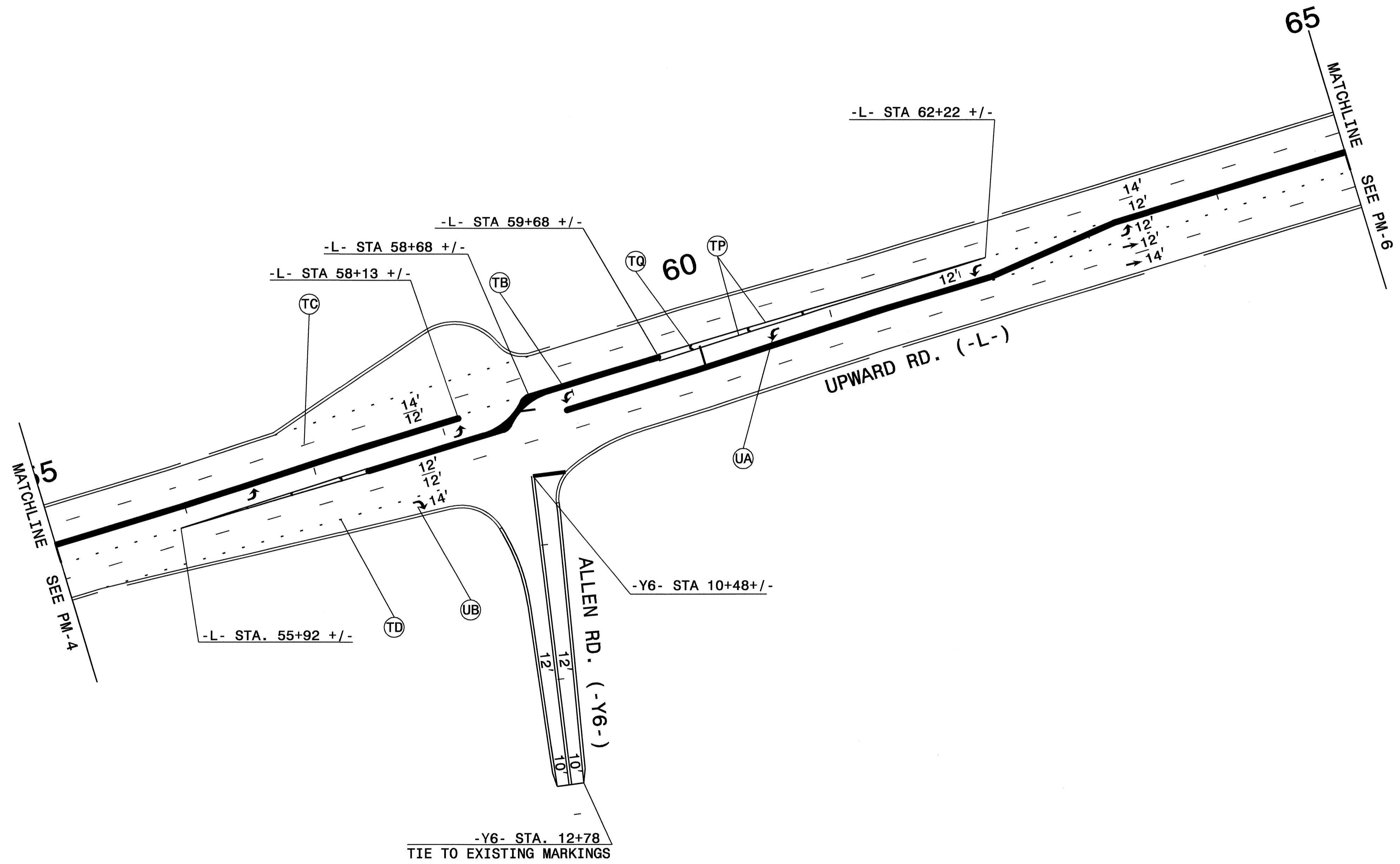
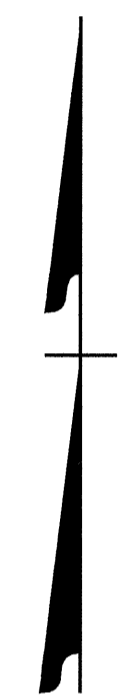

03-NOV-2008 12:04  
 \\dot\dfsroot\01\Projects-R-4430\traffic\trfficocontrol\top\drs pm\4430\_tc.pmp\_05.dgn  
 der\charlson AT WZTC237460

APPROVED: <i>John S. Kitt</i> DATE: 11/11/08	<b>PAVEMENT MARKING</b>		<table border="1"> <tr> <th colspan="2">REVISIONS</th> </tr> <tr> <td> </td> <td> </td> </tr> <tr> <td> </td> <td> </td> </tr> <tr> <td> </td> <td> </td> </tr> </table>		REVISIONS												
REVISIONS																	
	<table border="1"> <tr> <td>SCALE:</td> <td>NONE</td> </tr> <tr> <td>DATE:</td> <td>JUL - 08</td> </tr> <tr> <td>DWG. BY:</td> <td>DR</td> </tr> <tr> <td>DESIGN BY:</td> <td>DR</td> </tr> <tr> <td>REVIEWED BY:</td> <td>DAP</td> </tr> </table>	SCALE:	NONE	DATE:	JUL - 08	DWG. BY:	DR	DESIGN BY:	DR	REVIEWED BY:	DAP		<table border="1"> <tr> <td>CADD</td> <td> </td> </tr> <tr> <td>FILE</td> <td> </td> </tr> </table>	CADD		FILE	
SCALE:	NONE																
DATE:	JUL - 08																
DWG. BY:	DR																
DESIGN BY:	DR																
REVIEWED BY:	DAP																
CADD																	
FILE																	

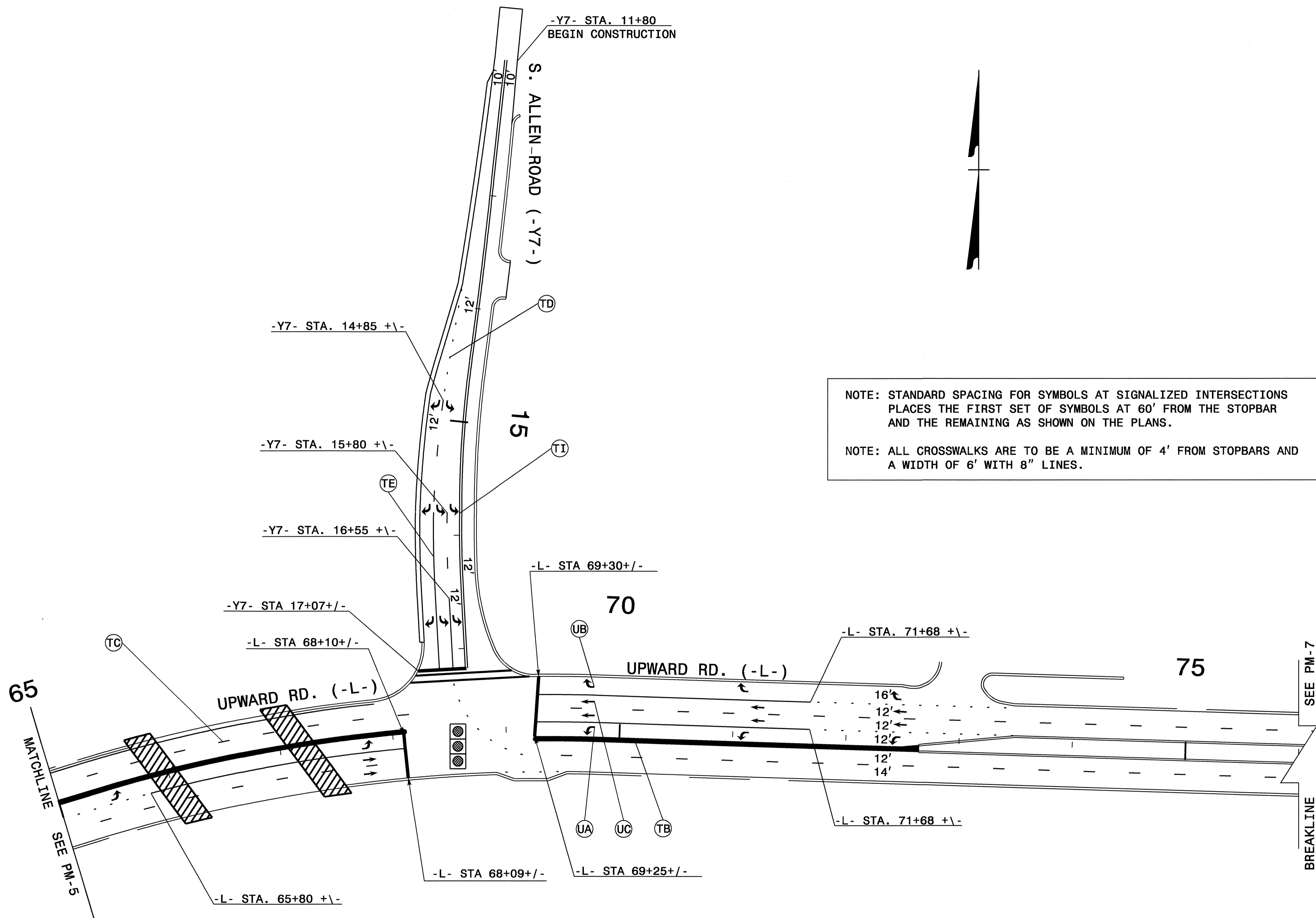

NOTE: STANDARD SPACING FOR SYMBOLS AT SIGNALIZED INTERSECTIONS PLACES THE FIRST SET OF SYMBOLS AT 60' FROM THE STOPBAR AND THE REMAINING AS SHOWN ON THE PLANS.

NOTE: ALL CROSSWALKS ARE TO BE A MINIMUM OF 4' FROM STOPBARS AND A WIDTH OF 6' WITH 8" LINES.

04-NOV-2008 17:42  
 \\dot\dfscoot01\Proj\pdp\projects-r\4430\trafficcontrol\top\drs pm\4430.tc.pmp\_06.dgn  
 AT WZTC237460  
 darichardson

APPROVED: <i>[Signature]</i> DATE: 11/4/07	<b>PAVEMENT MARKING</b>	
SCALE: NONE	REVISIONS	
DATE: JUL - 08		
DWG. BY: DR		
DESIGN BY: DR		
REVIEWED BY: DAP		CADD FILE

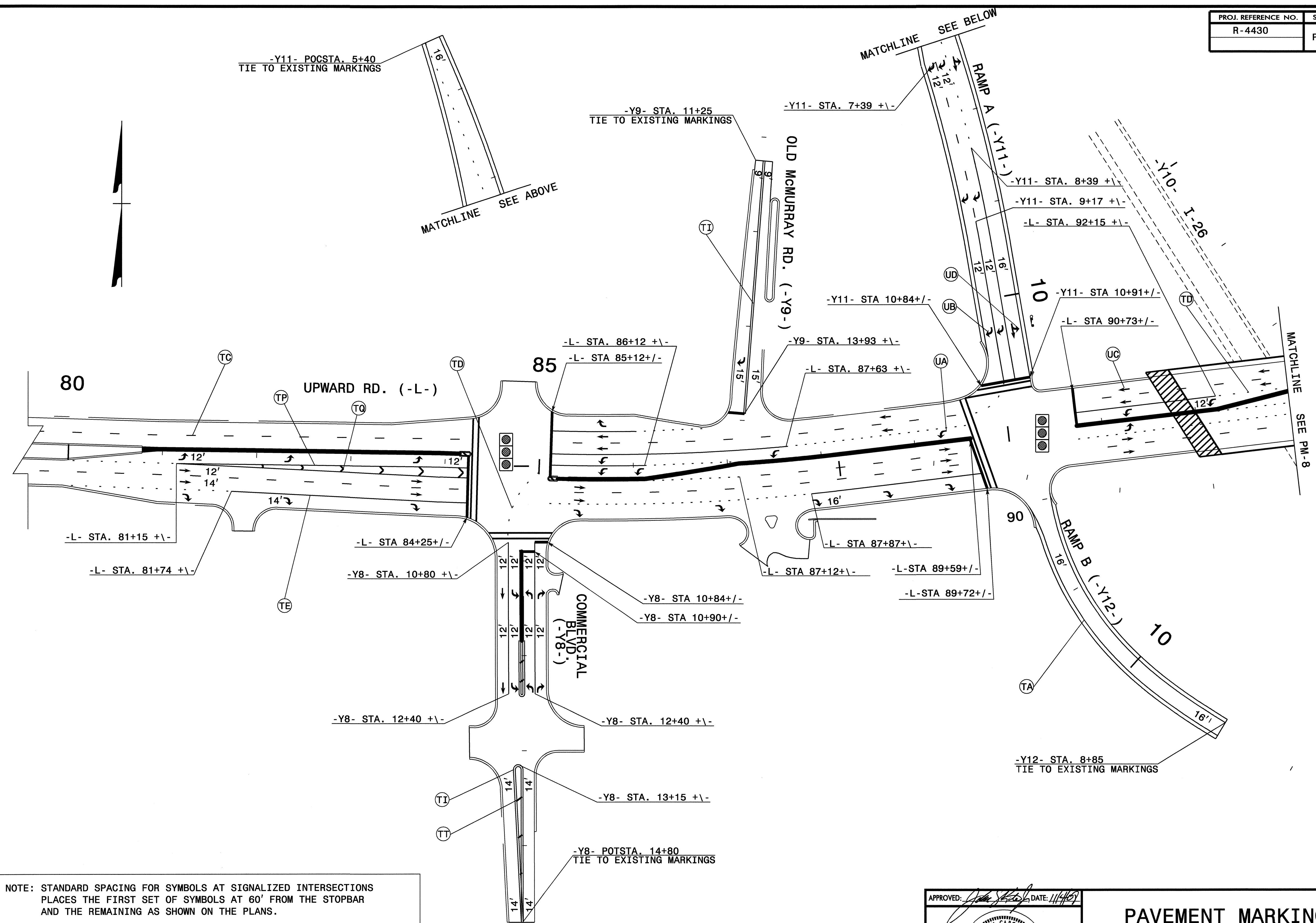

NOTE: STANDARD SPACING FOR SYMBOLS AT SIGNALIZED INTERSECTIONS PLACES THE FIRST SET OF SYMBOLS AT 60' FROM THE STOPBAR AND THE REMAINING AS SHOWN ON THE PLANS.

NOTE: ALL CROSSWALKS ARE TO BE A MINIMUM OF 4' FROM STOPBARS AND A WIDTH OF 6' WITH 8" LINES.

APPROVED: *[Signature]* DATE: 11/4/07

SEAL

### PAVEMENT MARKING

SCALE: NONE		REVISIONS
DATE: JUL-08		
DWG. BY: DR		
DESIGN BY: DR		
REVIEWED BY: DAP		

04-NOV-2008 17:42  
 \\dot\dfs\root0\Projects\Traffic\TrafficControl\top\dms pm\4430.tc.pmp\_07.dgn  
 AT WZTC237460  
 derichardson

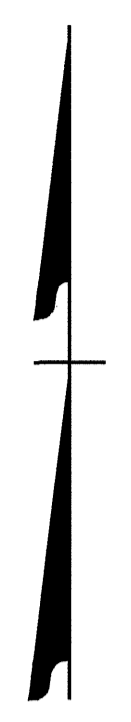
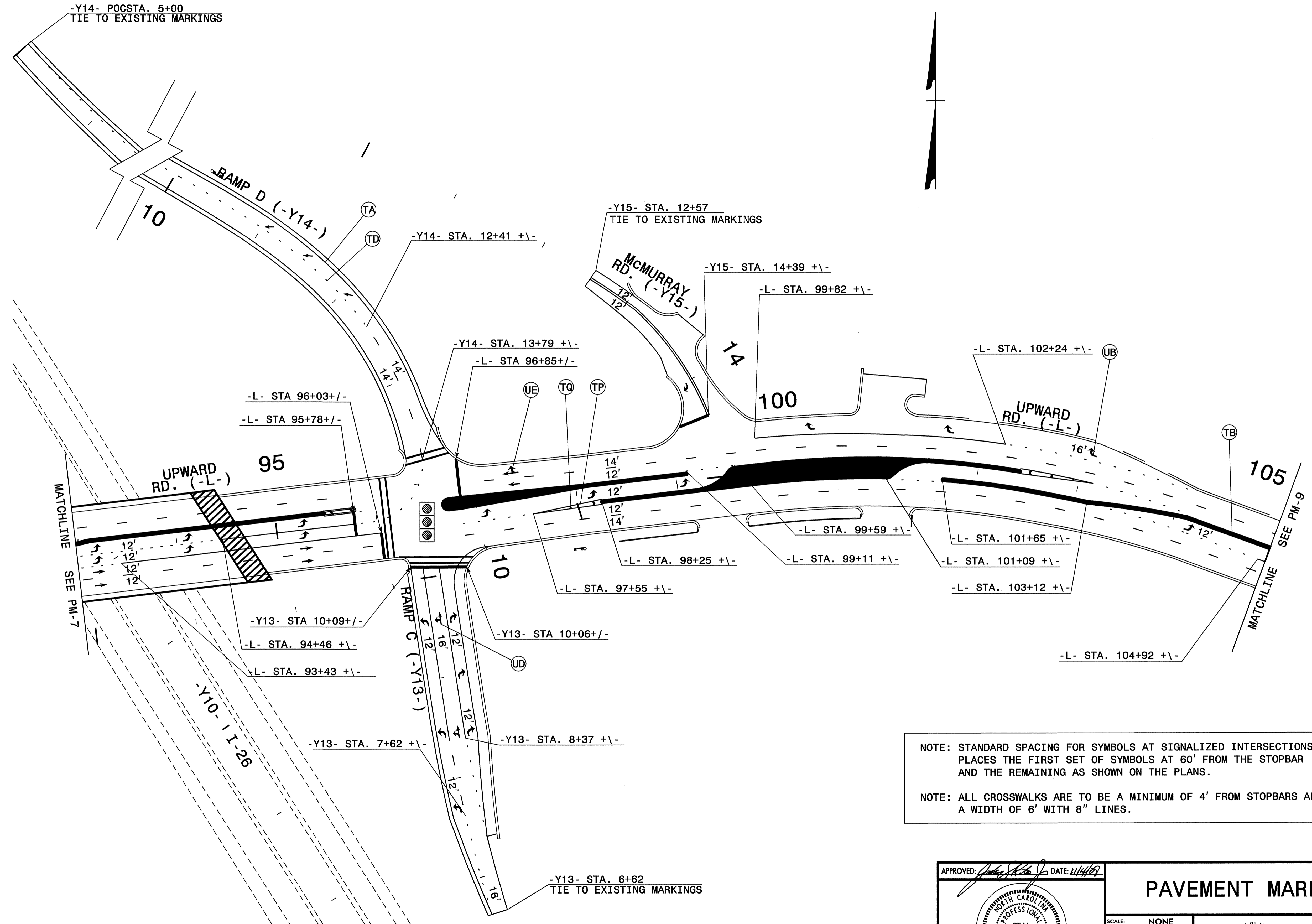

NOTE: STANDARD SPACING FOR SYMBOLS AT SIGNALIZED INTERSECTIONS PLACES THE FIRST SET OF SYMBOLS AT 60' FROM THE STOPBAR AND THE REMAINING AS SHOWN ON THE PLANS.

NOTE: ALL CROSSWALKS ARE TO BE A MINIMUM OF 4' FROM STOPBARS AND A WIDTH OF 6' WITH 8" LINES.

04-NOV-2008 17:42  
 \\dot\dfs\c00f01\Proj\Hippo\Projects\R-4430\Traffic\control\top\drs pm\Y-4430.tc.pmp.08.dgn  
 der\char\son AT WZTC237460

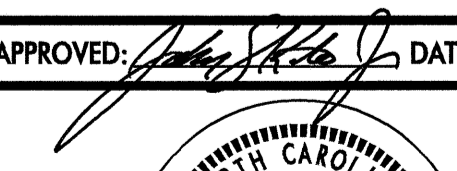
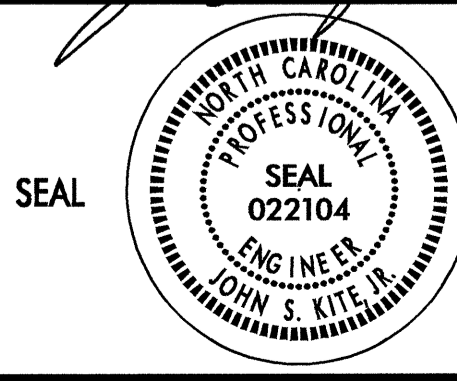
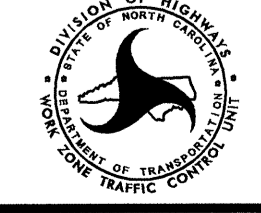
APPROVED: 	DATE: 11/4/08	<b>PAVEMENT MARKING</b>													
	SCALE: NONE														
	DATE: JUL-08	<table border="1"> <thead> <tr> <th colspan="2">REVISIONS</th> </tr> </thead> <tbody> <tr><td> </td><td> </td></tr> <tr><td> </td><td> </td></tr> <tr><td> </td><td> </td></tr> <tr><td> </td><td> </td></tr> </tbody> </table>				REVISIONS									
	REVISIONS														
DWG. BY: DR	DESIGN BY: DR	REVIEWED BY: DAP													



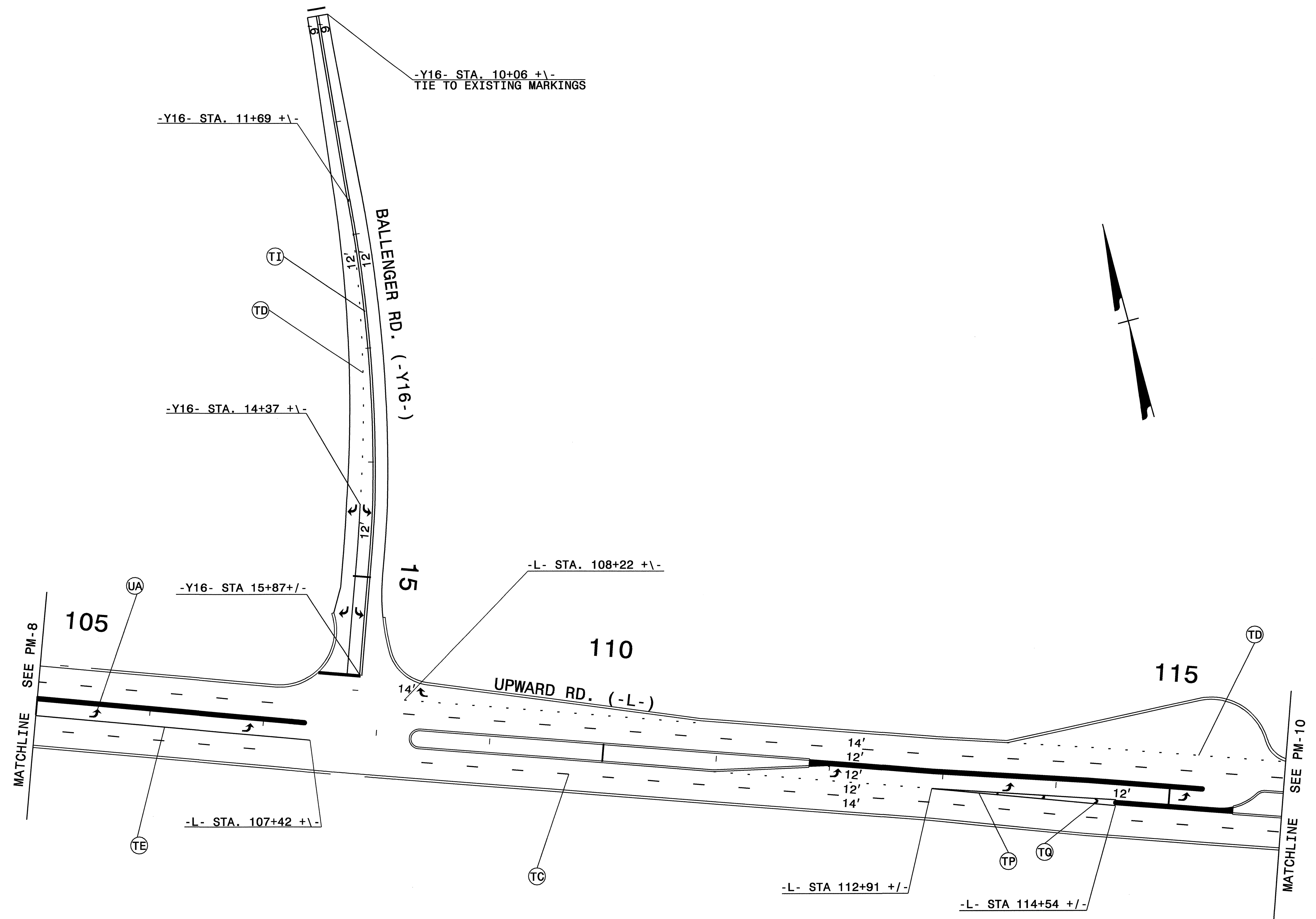

03-NOV-2008 12:06  
 \\dot\dfsroot\01\Proj\Hipp\projects-r\4430\traffic\trafficcontrol\top\drs pm\4430-to.pmp.09.dgn  
 der\char\son AT WZTC237460

APPROVED: <i>[Signature]</i> DATE: 11/4/08	<b>PAVEMENT MARKING</b>	
SCALE: NONE		REVISIONS
DATE: JUL-08		
DWG. BY: DR		
DESIGN BY: DR		
REVIEWED BY: DAP		CADD FILE

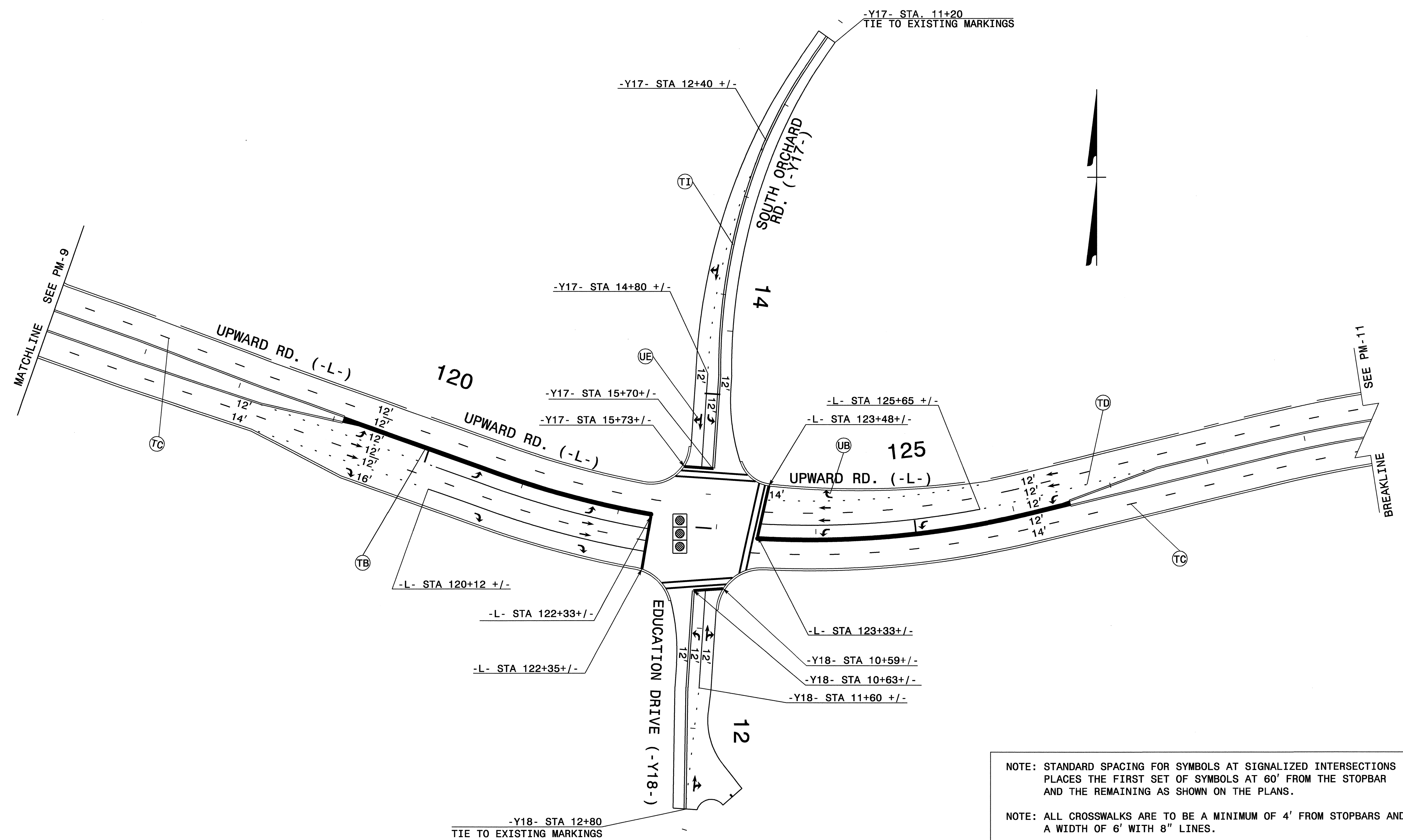

NOTE: STANDARD SPACING FOR SYMBOLS AT SIGNALIZED INTERSECTIONS PLACES THE FIRST SET OF SYMBOLS AT 60' FROM THE STOPBAR AND THE REMAINING AS SHOWN ON THE PLANS.

NOTE: ALL CROSSWALKS ARE TO BE A MINIMUM OF 4' FROM STOPBARS AND A WIDTH OF 6' WITH 8" LINES.

APPROVED: <i>[Signature]</i> DATE: 11/4/08	<b>PAVEMENT MARKING</b>		REVISIONS	
			SCALE: NONE	
	DATE: JUL - 08			
	DESIGN BY: DR			
	REVIEWED BY: DAP			

04-NOV-2008 17:42  
 \\dot\dfsroot\01\p\projects-r\4430\traffic\control\top\dr\pm\4430.tc.pmp.10.dgn  
 AT WZTC237460  
 derichardson

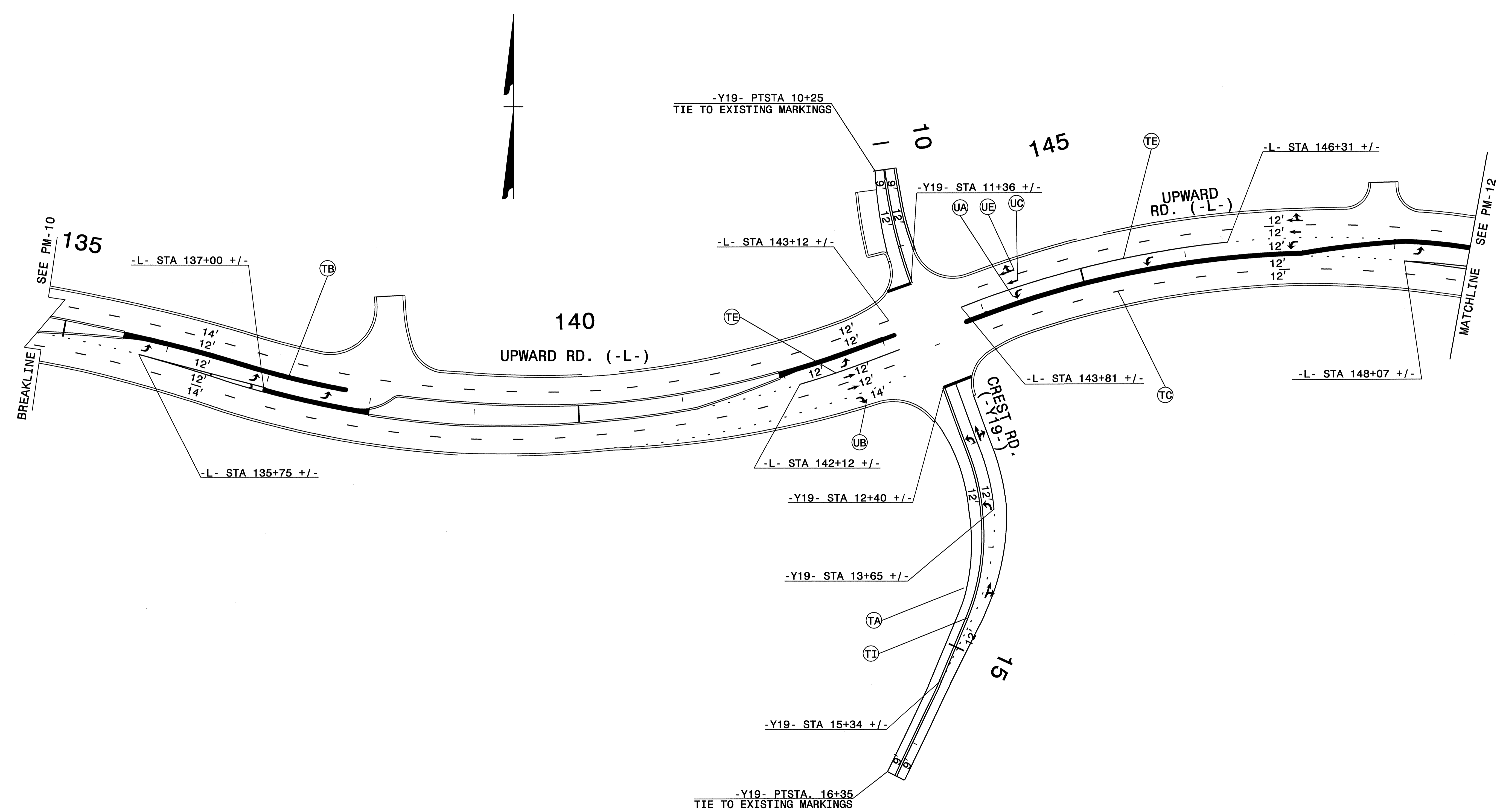

03-NOV-2008 12:06  
 \\dot.dferocof01\Projects-r\4430\traffic\trafficcontrol\top\drs pmV-4430.tc.pmp.ll.dgn  
 der\char-dson AT WZTC237460

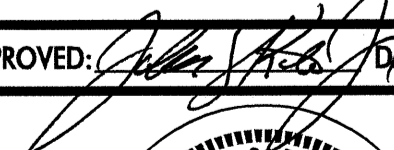
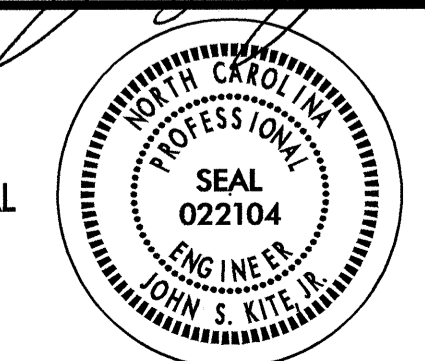
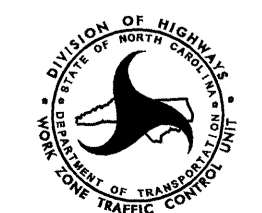
APPROVED:  DATE: 11/4/08	<b>PAVEMENT MARKING</b>	
		
SCALE: NONE		REVISIONS
DATE: JUL - 08		
DWG. BY: DR		
DESIGN BY: DR		
REVIEWED BY: DAP		CADD FILE

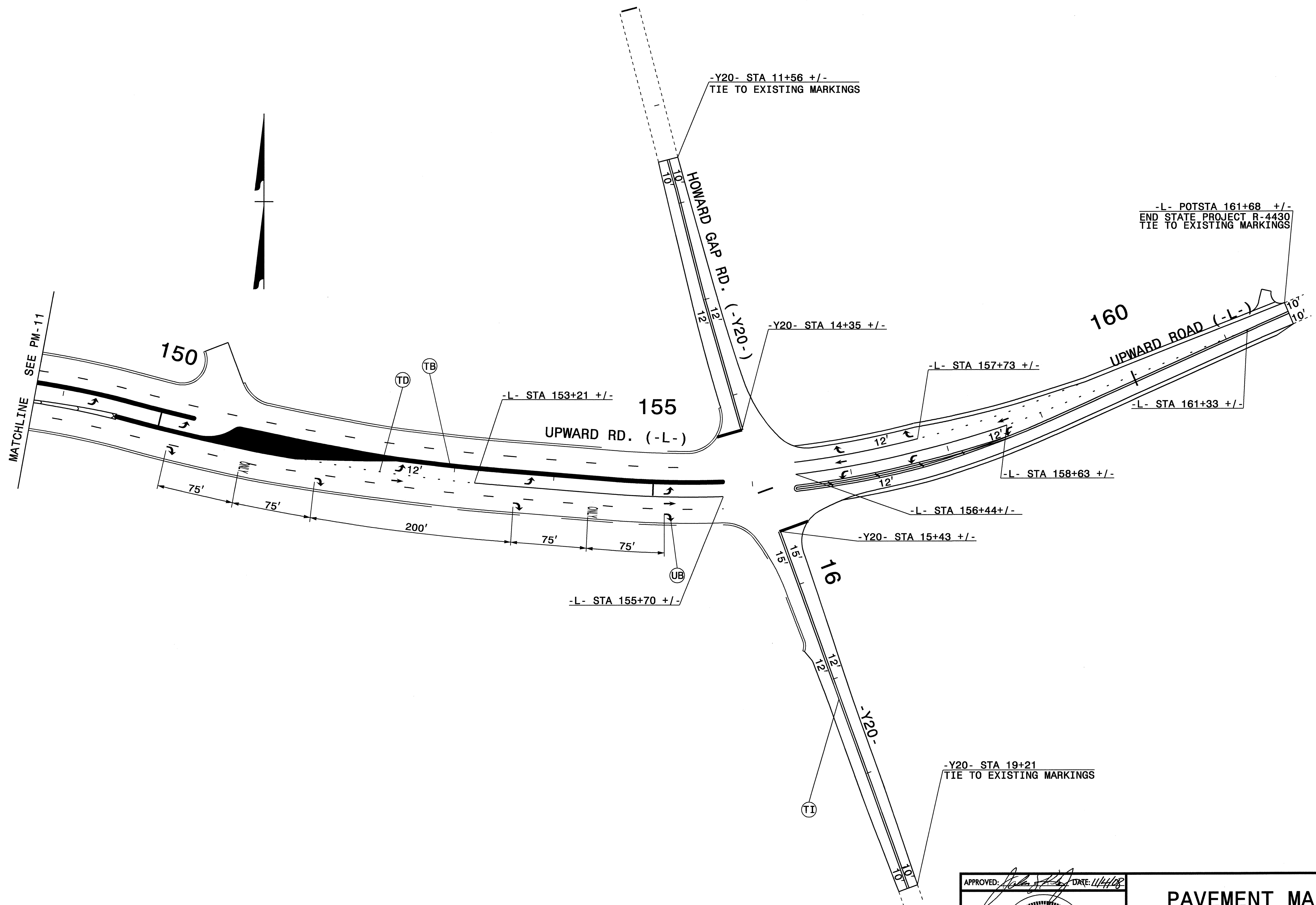

03-NOV-2008 12:06  
 \\dot\dfsroot\01\Proj\N\pp\projects-r\4430\traffic\trafficcontrol\top\drs pm\4430-to.pmp-12.dgn  
 der\char\son AT WZTC237460

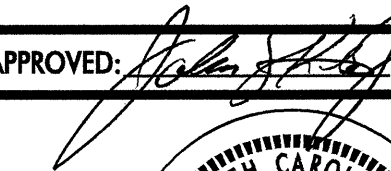
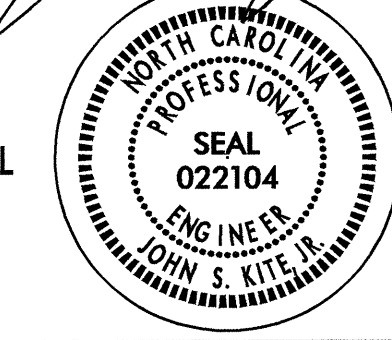
APPROVED: 	DATE: 11/4/08	<b>PAVEMENT MARKING</b>	
			
		DATE: JUL-08	REVISIONS
DWG. BY: DR			
DESIGN BY: DR			
REVIEWED BY: DAP			CADD FILE