

**STATE OF NORTH CAROLINA
DEPARTMENT OF TRANSPORTATION**

TIP NO. B-2576	SHEET NO. PMP-1
APPROVED: <i>Ayman Alqudwah</i>	
DATE: 5/7/09	
SEAL	



**PAVEMENT MARKING PLAN
IREDELL COUNTY**

**LOCATION: REPLACE BRIDGES 513 AND 514 ON
WILSON W. LEE BOULEVARD OVER NORFOLK
SOUTHERN RAILROAD IN STATESVILLE**

ROADWAY STANDARD DRAWING

THE FOLLOWING ROADWAY STANDARDS AS APPEAR IN "ROADWAY STANDARD DRAWINGS" - PROJECT SERVICES UNIT - N.C. DEPARTMENT OF TRANSPORTATION - RALEIGH, N.C., DATED JULY 2006 ARE APPLICABLE TO THIS PROJECT AND BY REFERENCE HEREBY ARE CONSIDERED A PART OF THESE PLANS:

STD. NO.	TITLE
1205.01	PAVEMENT MARKINGS - LINE TYPES AND OFFSETS
1205.02	PAVEMENT MARKINGS - 2 LANE AND MULTILANE ROADWAYS
1205.04	PAVEMENT MARKINGS - INTERSECTIONS
1205.05	PAVEMENT MARKINGS - TURN LANES
1205.06	PAVEMENT MARKINGS - THRU LANE DROPS
1205.08	PAVEMENT MARKINGS - SYMBOL AND WORD MESSAGES
1205.12	PAVEMENT MARKINGS - BRIDGES
1261.01	GUARDRAIL AND BARRIER DELINEATOR SPACING
1261.02	GUARDRAIL AND BARRIER DELINEATOR TYPES
1262.01	GUARDRAIL END DELINEATION

GENERAL NOTES

THE FOLLOWING GENERAL NOTES APPLY AT ALL TIMES FOR THE DURATION OF THE CONSTRUCTION PROJECT, EXCEPT WHEN OTHERWISE NOTED IN THE PLAN, OR DIRECTED BY THE ENGINEER.

A) INSTALL PAVEMENT MARKINGS AND PAVEMENT MARKERS ON THE FINAL SURFACE AS FOLLOWS:

ROAD NAME	MARKING	MARKER
-L- WILSON W. LEE BLVD.	PAINT	NONE

- B) PLACE TWO APPLICATIONS OF PAINT PAVEMENT MARKINGS ON THE FINAL WEARING SURFACE. PLACE THE SECOND APPLICATION OF PAINT UPON SUFFICIENT DRYING TIME OF THE FIRST.
- C) TIE PROPOSED PAVEMENT MARKING LINES TO EXISTING PAVEMENT MARKING LINES.
- D) REMOVE/REPLACE ANY CONFLICTING/DAMAGED PAVEMENT MARKINGS AND MARKERS.
- E) PASSING ZONES WILL BE DETERMINED IN THE FIELD AND MUST BE APPROVED BY THE ENGINEER.
- F) STOPBAR LOCATION AT NON-SIGNALIZED INTERSECTIONS MAY BE ADJUSTED AS DIRECTED BY THE ENGINEER.

INDEX

SHEET NO.	DESCRIPTION
PMP-1	PAVEMENT MARKING PLAN COVER SHEET
PMP-2	PAVEMENT MARKING SCHEDULE
PMP-3-4	PAVEMENT MARKING DETAIL

PLAN PREPARED BY: N.C.D.O.T. SIGNING AND DELINEATION UNIT

AYMAN ALQUDWAH SIGNING & DELINEATION REGIONAL ENGINEER
DERRICK BEARD SIGNING & DELINEATION PROJECT DESIGN ENGINEER/TECHNICIAN

T.I.P.: B-2576

CONTRACT:

TIP NO.	SHEET NO.
B-2576	PMP-2
APPROVED: <i>[Signature]</i>	
DATE: 5/7/09	
SEAL	

B-2576 FINAL PAVEMENT MARKING SCHEDULE

SYMBOL	DESCRIPTION	FINAL PAVEMENT MARKINGS	PAY ITEM QUANTITY	TOTAL
		<u>PAINT (24")</u>		
P4	WHITE STOPBAR		112 LF	TOTAL 112 LF
		<u>PAINT (4")</u>		
PA	WHITE EDGELINE		754 LF	TOTAL 6070 LF
PD	2 FT. WHITE MINISKIP		72 LF	
PE	WHITE SOLID LANE LINE		440 LF	
PI	YELLOW DOUBLE CENTER		4804 LF	
		<u>PAINT (8")</u>		
PS	WHITE DIAGONAL		106 LF	TOTAL 106 LF
		<u>PAINTMARKING CHARACTERS</u>		
QI	ALPHANUMERIC CHAR.		8 EA	TOTAL 8 EA
		<u>PAINTMARKING SYMBOLS</u>		
QB	RIGHT TURN ARROW		14 EA	TOTAL 14 EA

FINAL PAVEMENT MARKING SCHEDULE

07-MAY-2009 11:27
 r:\traffic\signing\cadd\pmp\b-2576.sgn_pmp_2.dgn
 dhbeard

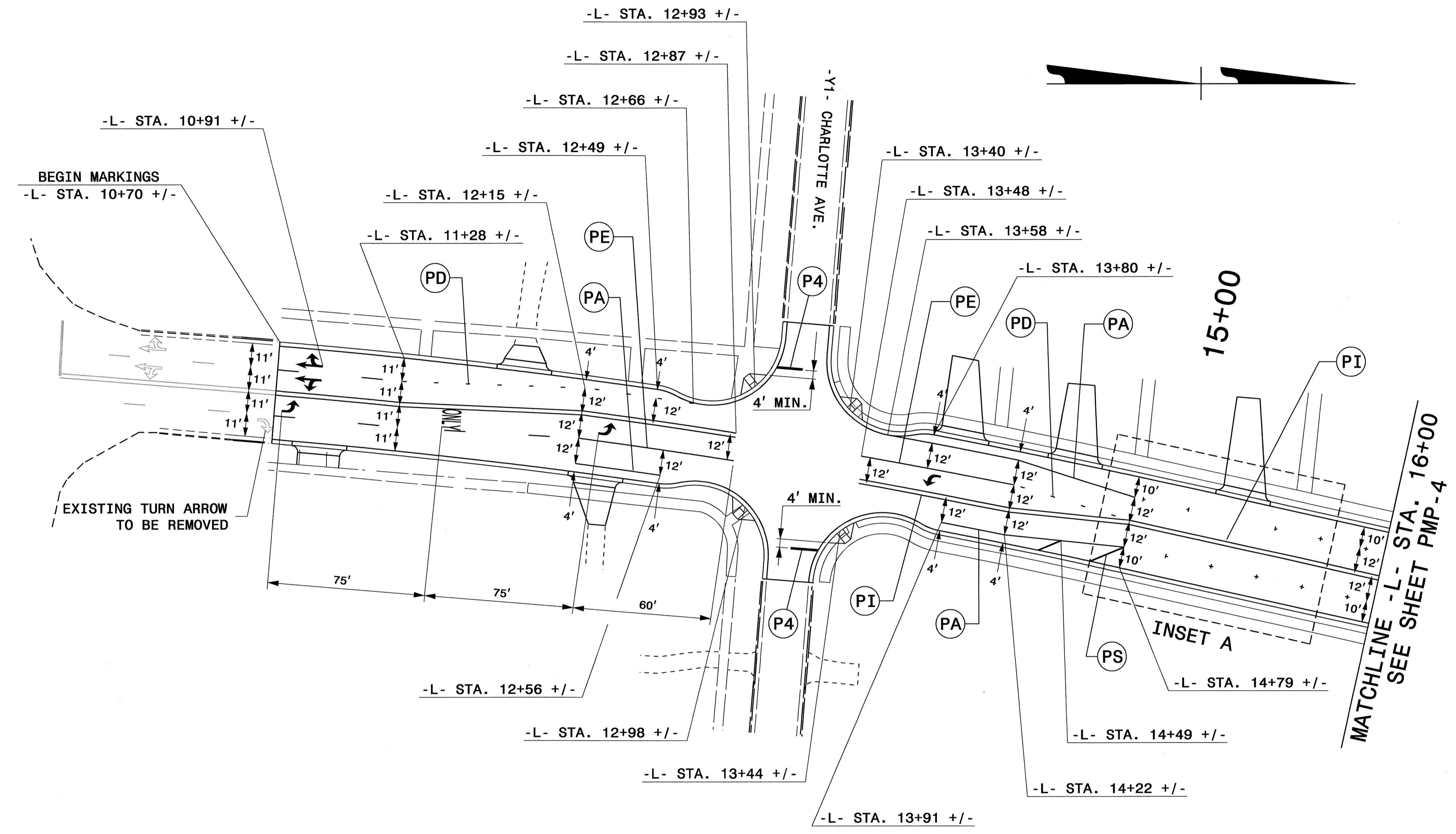

INSET A

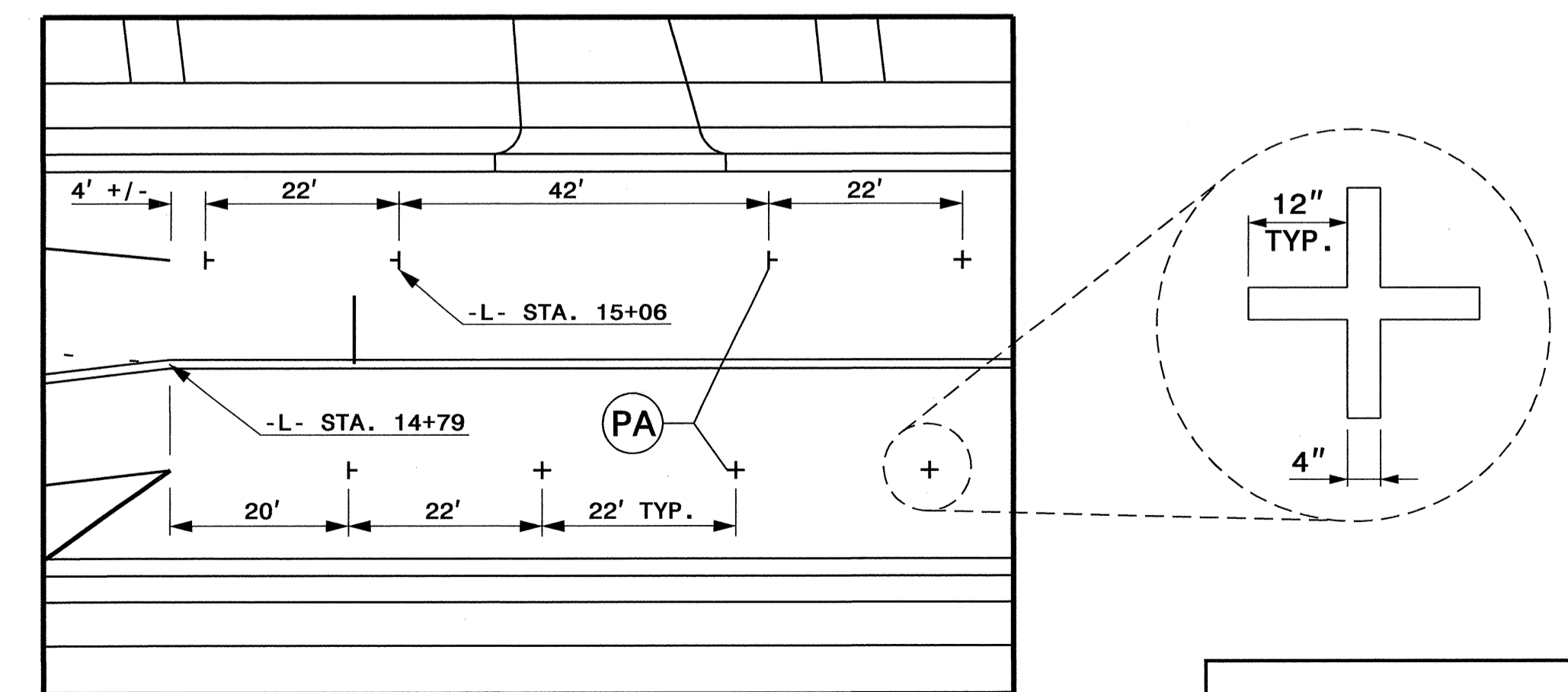

PAVEMENT MARKING DETAIL

SYMBOL AND PAVEMENT MARKING LEGEND	
(QA) LEFT TURN ARROW	(PA) WHITE EDGE LINE 4"
(QD) COMBO STRAIGHT/LEFT ARROW	(PD) WHITE MINI SKIP 4"
(QE) COMBO STRAIGHT/RIGHT ARROW	(PE) WHITE SOLID LANE LINE 4"
ONLY (QI) ALPHANUMERIC CHARACTER	(PI) YELLOW DOUBLE CENTER 4"
	(PS) WHITE DIAGONAL 8"
	(P4) WHITE STOPBAR 24"

07-MAY-2009 11:33
 F:\trac\pmp\cadd\pmp\B-2576_Sgn_PMP_3.dgn
 dibeard A WZT0244736

TIP NO.	SHEET NO.
B-2576	PMP-4
APPROVED: <i>[Signature]</i>	
DATE: 6/9/09	
SEAL	
	

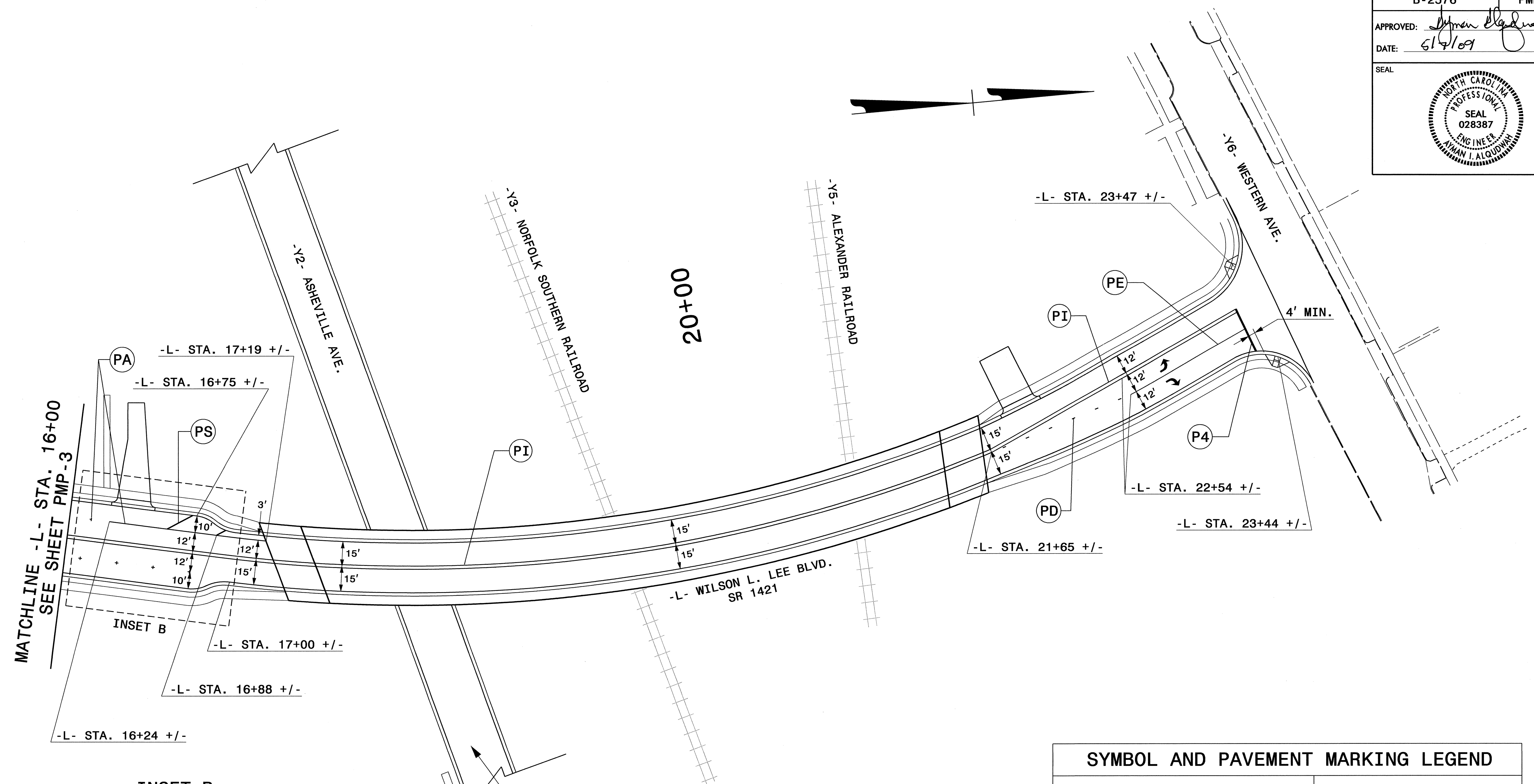

MATCHLINE -L- STA. 16+00
SEE SHEET PMP-3

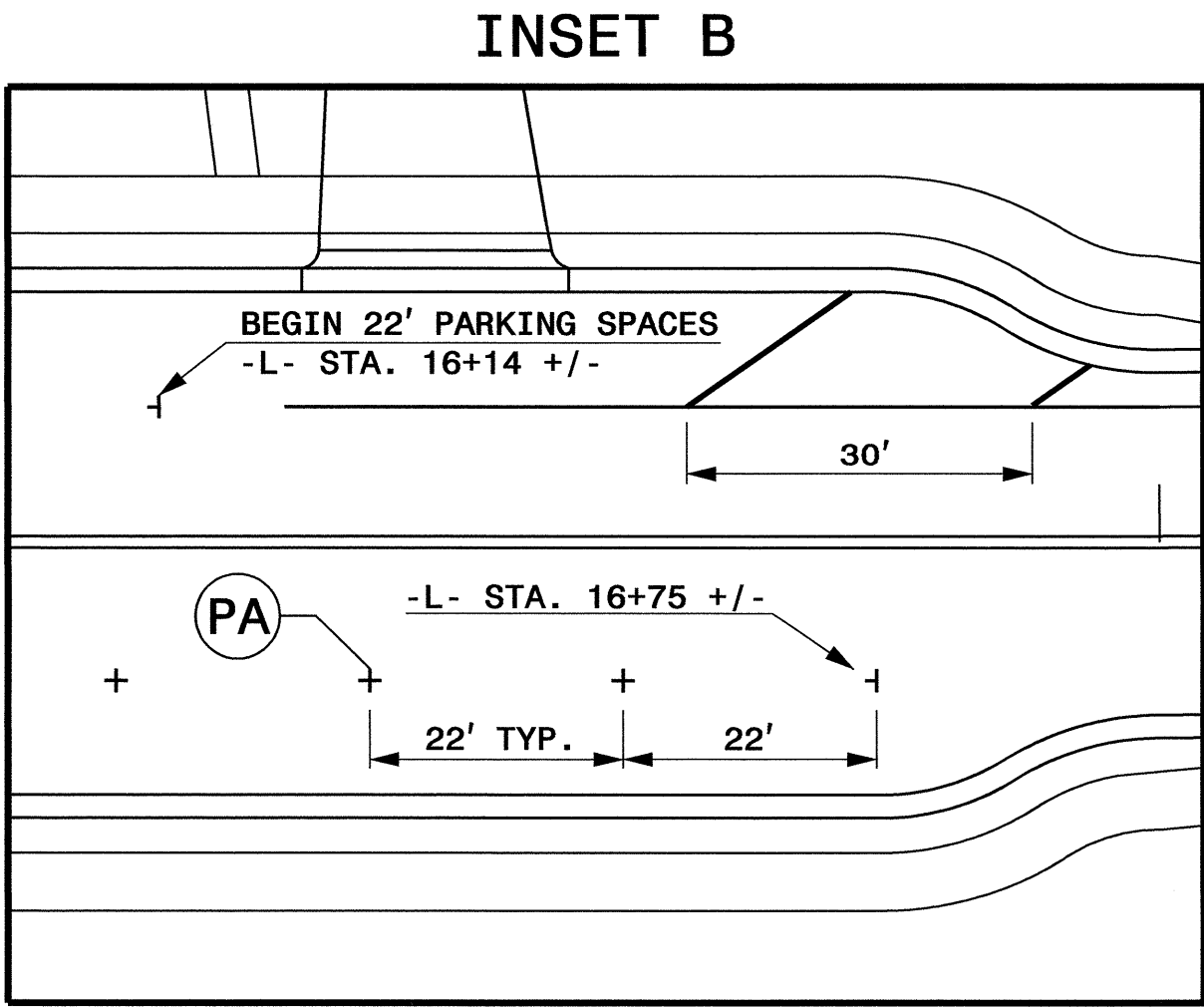

NO PAVEMENT MARKINGS NEEDED FOR -Y2- ASHEVILLE AVE.

SYMBOL AND PAVEMENT MARKING LEGEND	
	(QA) LEFT TURN ARROW
	(QB) RIGHT TURN ARROW
	(PA) WHITE EDGE LINE 4"
	(PD) WHITE MINI SKIP 4"
	(PE) WHITE SOLID LANE LINE 4"
	(PI) YELLOW DOUBLE CENTER 4"
	(PS) WHITE DIAGONAL 8"
	(P4) WHITE STOPBAR 24"

PAVEMENT MARKING DETAIL

07-MAY-2009 11:34
r:\traffic\signing\cadd\pmp\B-2576.Sgn_PMP_4.dgn
dhbeard AT WZT 0244736