

TIP PROJECT: I-5143

CONTRACT: C202561

See Sheet 1-A For Index of Sheets
See Sheet 1-B For Conventional Symbols

STATE OF NORTH CAROLINA

DIVISION OF HIGHWAYS

CATAWBA COUNTY

STATE	STATE PROJECT REFERENCE NO.	SHEET NO.	TOTAL SHEETS
N.C.	I-5143	1	
STATE PROJ. NO.	F.A. PROJ. NO.	DESCRIPTION	
45329.1.1	IMS-040-2(147)123	P.E.	
45329.3.1	IMS-040-2(147)123	CONSTRUCTION	

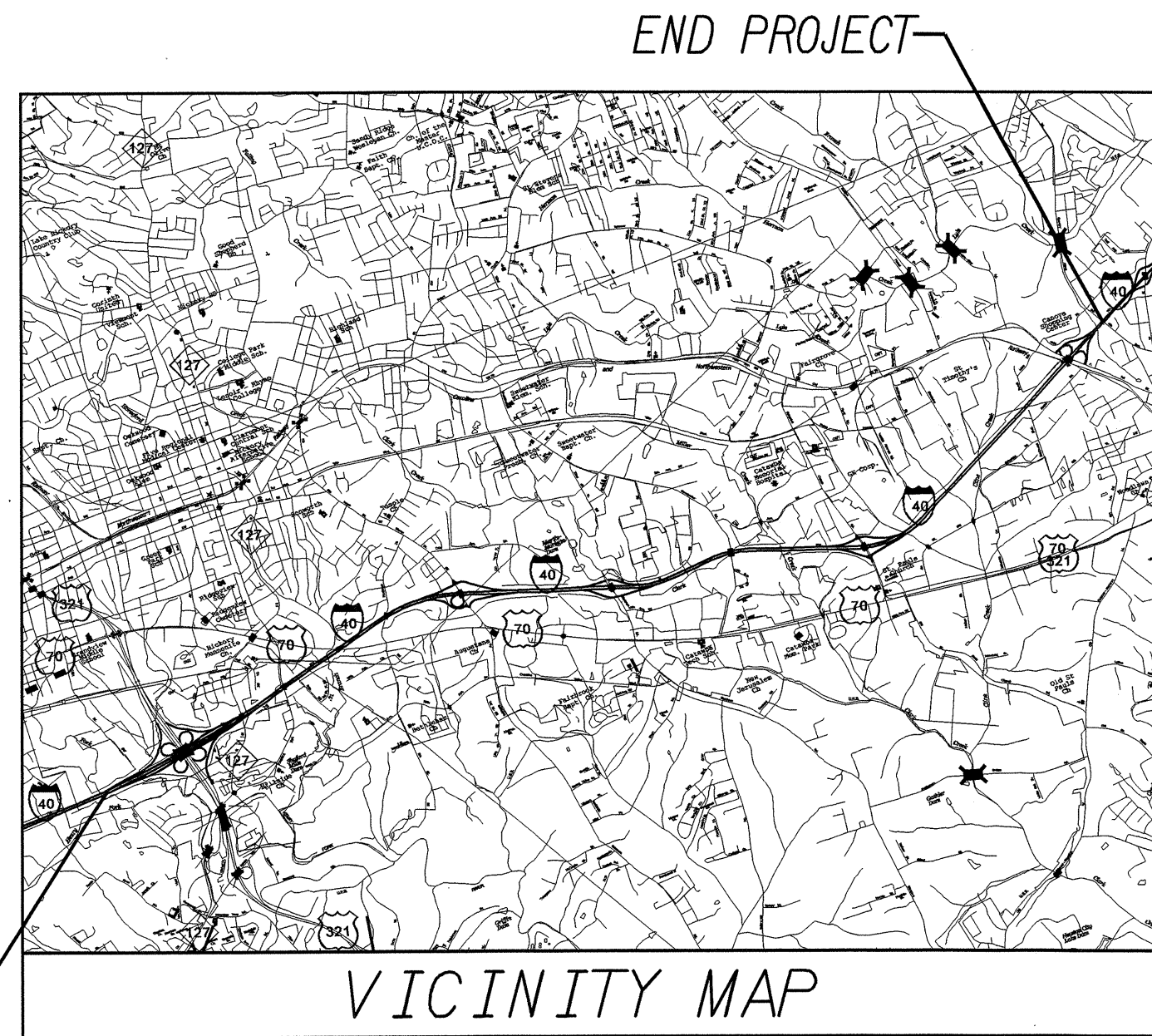

LOCATION: I-40 AT THE INTERSECTIONS OF US 321 (EXIT 123), SR 1007 (LENOIR RHYNE BOULEVARD - EXIT 125), SR 1005 (MCDONALD PARKWAY - EXIT 126), SR 1476 (FAIRGROVE CHURCH ROAD - EXIT 128) AND 1ST. STREET WEST (EXIT 130) IN HICKORY.

TYPE OF WORK: LIGHTING RENOVATION

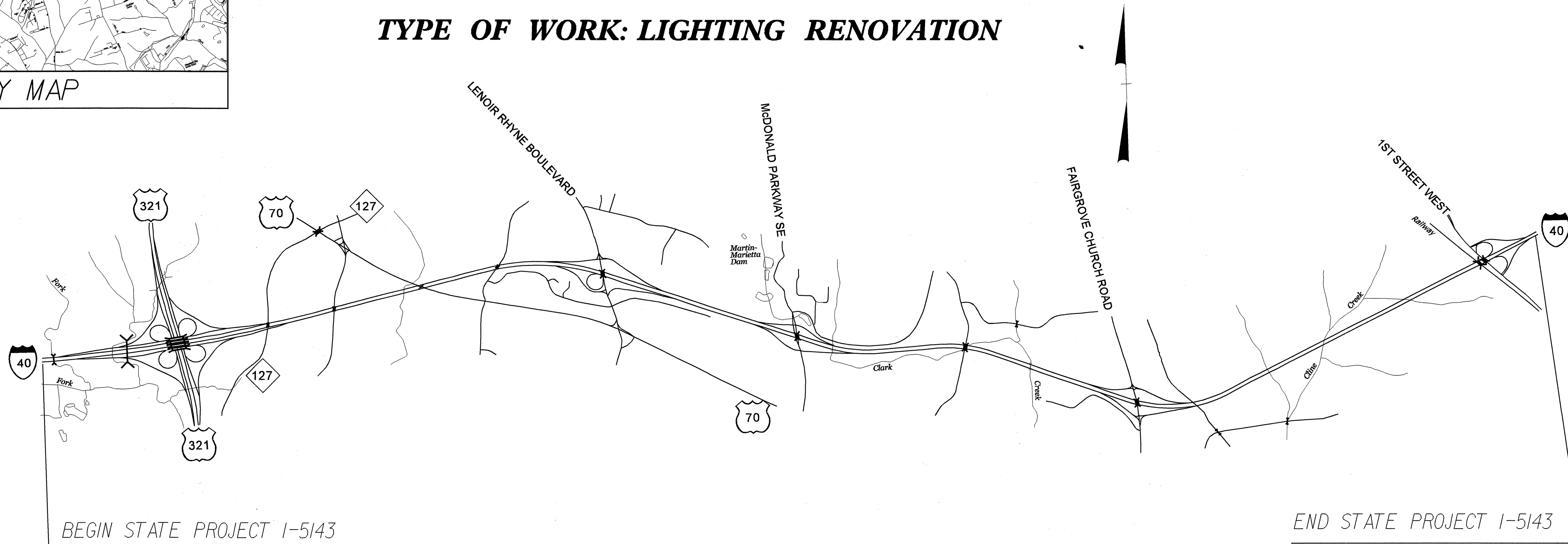

BEGIN PROJECT

BEGIN STATE PROJECT I-5143

END STATE PROJECT I-5143

GRAPHIC SCALE



PROJECT LENGTH

LENGTH ROADWAY TIP PROJECT I-5143 = 8.3 MILES
TOTAL LENGTH TIP PROJECT I-5143 = 8.3 MILES

Prepared In the Office of:

DIVISION OF HIGHWAYS

2006 STANDARD SPECIFICATIONS

RIGHT OF WAY DATE:
N/A

LETTING DATE:
FEBRUARY 16, 2010

CHRISTOPHER K. HAIRE, PE
PROJECT ENGINEER

JAY A. STENCIL
PROJECT DESIGN ENGINEER

LIGHTING DESIGN ENGINEER

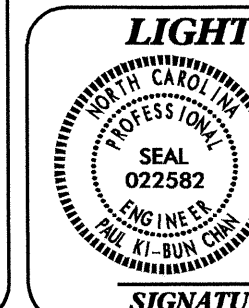

SIGNATURE:

Paul J. Blum 12-21-09
P.E.

DIVISION OF HIGHWAYS
STATE OF NORTH CAROLINA

STATE DESIGN ENGINEER P.E.

DEPARTMENT OF TRANSPORTATION
FEDERAL HIGHWAY ADMINISTRATION

APPROVED
DIVISION ADMINISTRATOR

DATE

INDEX OF SHEETS

SHEET NUMBER

1
1-A
1-B
2
E-1 THRU E-13

SHEET

TITLE SHEET
INDEX OF SHEETS
CONVENTIONAL SYMBOLS
SUMMARY OF QUANTITIES
LIGHTING PLANS

STATE OF NORTH CAROLINA
DIVISION OF HIGHWAYS

*S.U.E = SUBSURFACE UTILITY ENGINEER

CONVENTIONAL SYMBOLS

ROADS & RELATED ITEMS

Edge of Pavement	-----
Curb	-----
Prop. Slope Stakes Cut	----- ^C -----
Prop. Slope Stakes Fill	----- ^F -----
Prop. Woven Wire Fence	○-----○
Prop. Chain Link Fence	□-----□
Prop. Barbed Wire Fence	◇-----◇
Prop. Wheelchair Ramp	(WCR)
Exist. Guardrail	-----
Prop. Guardrail	-----
Equality Symbol	⊕
Pavement Removal	⊗

RIGHT OF WAY

Right of Way Marker	▲
Exist. Right of Way Line w/Marker	△
Prop. Right of Way Line (Iron Pin & Cap Set By Others)	▲
Prop. Right of Way Line (Standard Concrete Marker Set By Contract)	▲
Exist. Control of Access Line	⊕
Prop. Control of Access Line	⊕
Exist. Easement Line	----- ^E -----
Prop. Temp. Construction Easement Line	----- ^E -----
Prop. Temp. Drainage Easement Line	----- ^{TDE} -----
Prop. Perm. Drainage Easement Line	----- ^{PDE} -----

HYDROLOGY

Stream or Body of Water	-----
Flow Arrow	→
Disappearing Stream	-----
Spring	-----
Swamp Marsh	-----
Shoreline	-----
Falls, Rapids	-----
Prop Lateral, Tail, Head Ditches	-----

STRUCTURES

MAJOR	
Bridge, Tunnel, or Box Culvert	CONC
Bridge Wing Wall, Head Wall and End Wall	CONC HW

MINOR	
Head & End Wall	CONC HW
Pipe Culvert	=====
Footbridge	-----
Drainage Boxes	□ CB
Paved Ditch Gutter	-----

UTILITIES

Exist. Pole	•
Exist. Power Pole	•
Prop. Power Pole	○
Exist. Telephone Pole	•
Prop. Telephone Pole	○
Exist. Joint Use Pole	•
Prop. Joint Use Pole	○
Telephone Pedestal	⊕
Cable TV Pedestal	⊕
Hydrant	⊕
Satellite Dish	∠
Exist. Water Valve	⊗
Sewer Clean Out	⊕
Power Manhole	⊕
Telephone Booth	⊕
Water Manhole	⊕
Light Pole	⊕
H-Frame Pole	⊕
Power Line Tower	⊕
Pole with Base	⊕
Gas Valve	◇
Gas Meter	◇
Telephone Manhole	⊕
Power Transformer	⊕
Sanitary Sewer Manhole	⊕
Storm Sewer Manhole	⊕
Tank; Water, Gas, Oil	○
Water Tank With Legs	○
Traffic Signal Junction Box	⊕
Fiber Optic Splice Box	⊕
Television or Radio Tower	⊕
Utility Power Line Connects to Traffic Signal Lines Cut Into the Pavement	-----

Recorded Water Line	-----
Designated Water Line (S.U.E.*)	-----
Sanitary Sewer	-----
Recorded Sanitary Sewer Force Main	-----
Designated Sanitary Sewer Force Main(S.U.E.*)	-----
Recorded Gas Line	-----
Designated Gas Line (S.U.E.*)	-----
Storm Sewer	-----
Recorded Power Line	-----
Designated Power Line (S.U.E.*)	-----
Recorded Telephone Cable	-----
Designated Telephone Cable (S.U.E.*)	-----
Recorded U/G Telephone Conduit	-----
Designated U/G Telephone Conduit (S.U.E.*)	-----
Unknown Utility (S.U.E.*)	-----
Recorded Television Cable	-----
Designated Television Cable (S.U.E.*)	-----
Recorded Fiber Optics Cable	-----
Designated Fiber Optics Cable (S.U.E.*)	-----
Exist. Water Meter	⊕
U/G Test Hole (S.U.E.*)	⊕
Abandoned According to U/G Record	ATTUR
End of Information	E.O.I.

BOUNDARIES & PROPERTIES

State Line	-----
County Line	-----
Township Line	-----
City Line	-----
Reservation Line	-----
Property Line	-----
Property Line Symbol	⊕
Exist. Iron Pin	⊕
Property Corner	+
Property Monument	⊕
Property Number	123
Parcel Number	6
Fence Line	-----
Existing Wetland Boundaries	-----
Proposed Wetland Boundaries	-----
Existing Endangered Animal Boundaries	-----
Existing Endangered Plant Boundaries	-----

BUILDINGS & OTHER CULTURE

Buildings	-----
Foundations	-----
Area Outline	-----
Gate	-----
Gas Pump Vent or U/G Tank Cap	-----
Church	-----
School	-----
Park	-----
Cemetery	-----
Dam	-----
Sign	-----
Well	-----
Small Mine	-----
Swimming Pool	-----

TOPOGRAPHY

Loose Surface	-----
Hard Surface	-----
Change in Road Surface	-----
Curb	-----
Right of Way Symbol	R/W
Guard Post	○ GP
Paved Walk	-----
Bridge	-----
Box Culvert or Tunnel	-----
Ferry	-----
Culvert	-----
Footbridge	-----
Trail, Footpath	-----
Light House	-----

VEGETATION

Single Tree	-----
Single Shrub	-----
Hedge	-----
Woods Line	-----
Orchard	-----
Vineyard	VINEYARD

RAILROADS

Standard Gauge	-----
RR Signal Milepost	-----
Switch	-----

15-DEC-2009 14:36 c:\peta\1-10\1-5143\1-5143\tracing\ceterba.cad.tah.dgn

STATE OF NORTH CAROLINA DIVISION OF HIGHWAYS SUMMARY OF QUANTITIES

STATE OF NORTH CAROLINA DIVISION OF HIGHWAYS ROADWAY SUMMARY OF QUANTITIES FOR CONTRACT - C202561

ItemNumber	Sec #	Quantity	Unit	Description	ItemNumber	Sec #	Quantity	Unit	Description
000100000-N	800	Lump Sum		MOBILIZATION	517500000-E	1410	310	LF	** #6 W/G FEEDER CIRCUIT (2)
008800000-E	200	0.8	ACR	SUPPLEMENTARY CLEARING & GRUB-BING	518000000-E	1410	2,073	LF	** #4 W/G FEEDER CIRCUIT (2)
303000000-E	862	2,040	LF	STEEL BM GUARDRAIL	518500000-E	1410	3,200	LF	** #2 W/G FEEDER CIRCUIT (2)
319500000-N	862	1	EA	GUARDRAIL ANCHOR UNITS, TYPE AT-1	519000000-E	1410	490	LF	***** FEEDER CIRCUIT (2 #1)
321000000-N	862	44	EA	GUARDRAIL ANCHOR UNITS, TYPE CAT-1	520500000-E	1410	3,789	LF	** #8 W/G FEEDER CIRCUIT IN ***** CONDUIT (2, 1.5")
328500000-N	SP	42	EA	GUARDRAIL ANCHOR UNITS, TYPE M-350	521000000-E	1410	2,592	LF	** #6 W/G FEEDER CIRCUIT IN ***** CONDUIT (2, 1.5")
338960000-N	865	2	EA	CABLE GUIDERAIL ANCHOR UNITS	521500000-E	1410	17,869	LF	** #4 W/G FEEDER CIRCUIT IN ***** CONDUIT (2, 1.5")
458900000-N	SP	Lump Sum		GENERIC TRAFFIC CONTROL ITEM TRAFFIC CONTROL	522000000-E	1410	12,586	LF	** #2 W/G FEEDER CIRCUIT IN ***** CONDUIT (2, 1.5")
502000000-N	1401	1	EA	PORTABLE DRIVE UNIT	522500000-E	1410	2,830	LF	** #1 W/G FEEDER CIRCUIT IN ***** CONDUIT (2, 1.5")
502500000-E	1402	223	CY	HIGH MOUNT FOUNDATIONS	524000000-N	1411	106	EA	ELECTRICAL JUNCTION BOXES ***** (PC18)
503000000-N	1403	232	EA	HIGH MOUNT LUMINAIRES ***** (400W HPS)	524000000-N	1411	23	EA	ELECTRICAL JUNCTION BOXES ***** (PC36)
503000000-N	1403	96	EA	HIGH MOUNT LUMINAIRES ***** (750W HPS)	527000000-N	SP	4	EA	GENERIC LIGHTING ITEM 100' HIGH MOUNT STANDARD
512000000-N	1407	1	EA	ELECTRIC SERVICE POLE ***** (30' CLASS 4)	527000000-N	SP	9	EA	GENERIC LIGHTING ITEM 120' HIGH MOUNT STANDARD
512500000-E	1407	530	LF	ELECTRIC SERVICE LATERAL ***** (3 #1/0 USE)	527000000-N	SP	29	EA	GENERIC LIGHTING ITEM 80' HIGH MOUNT STANDARD
515500000-E	1409	875	LF	ELECTRICAL DUCT, TYPE BD, SIZE ***** (2")	527000000-N	SP	6	EA	GENERIC LIGHTING ITEM LIGHT CONTROL SYSTEM
515500000-E	1409	950	LF	ELECTRICAL DUCT, TYPE BD, SIZE ***** (3")	527000000-N	SP	5	EA	GENERIC LIGHTING ITEM REMOVE CONTROL SYSTEM
516000000-E	1409	1,075	LF	ELECTRICAL DUCT, TYPE JA, SIZE ***** (3")	527000000-N	SP	46	EA	GENERIC LIGHTING ITEM REMOVE HIGH MAST LIGHT STANDARD
516000000-E	1409	465	LF	ELECTRICAL DUCT, TYPE JA, SIZE ***** (4")	527000000-N	SP	46	EA	GENERIC LIGHTING ITEM REMOVE HM LGT STANDARD FOUNDATION
516000000-E	1409	455	LF	ELECTRICAL DUCT, TYPE JA, SIZE ***** (6")					
517000000-E	1410	1,050	LF	** #8 W/G FEEDER CIRCUIT (2)					

ItemNumber	Sec #	Quantity	Unit	Description
527000000-N	SP	18	EA	GENERIC LIGHTING ITEM REMOVE LIGHT STANDARD
527000000-N	SP	18	EA	GENERIC LIGHTING ITEM REMOVE LIGHT STANDARD FOUNDATION
608400000-E	1660	0.8	ACR	SEEDING & MULCHING

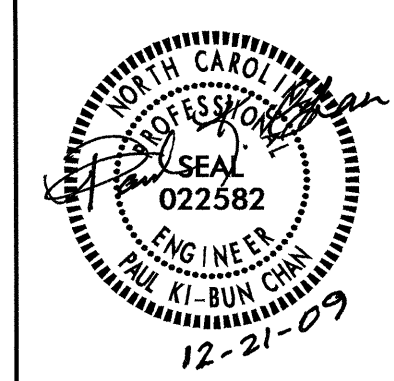

PLANS AND DETAILS FOR PROPOSED LIGHTING /ELECTRICAL CONSTRUCTION

NOTES

- 1 AT THESE LOCATIONS, PROVIDE ELECTRICAL DUCT IN ACCORDANCE WITH NEC REQUIREMENTS FOR AN APPROVED RACEWAY FOR ELECTRICAL CIRCUITS. SEE TABLE "C"
- 2 INSTALL ALL BORE PITS OUTSIDE THE CLEAR ZONE, AS DEFINED BY THE 2002 AASHTO ROADSIDE DESIGN GUIDE OR AS DIRECTED BY THE ENGINEER.
- 3 LOCATE ALL JUNCTION BOXES OUTSIDE CLEAR ZONE AND IN AN AREA UNLIKELY TO BE USED BY TRAFFIC.
- 4 LOCATE PROPOSED CONTROL SYSTEM IN AN AREA ACCESSIBLE FOR MAINTENANCE VEHICLES AND OUTSIDE OF CLEAR ZONE AS DEFINED BY THE 2002 AASHTO ROADSIDE DESIGN GUIDE.
- 5 TYPE PC18 JUNCTION BOXES ARE 18" L X 12" W X 18" H.
- 6 TYPE PC36 JUNCTION BOXES ARE 36" L X 24" W X 18" H.
- 7 USE SCALED DIMENSIONS TO LOCATE PROPOSED ALL LIGHTING ITEMS.
- 8 INSTALL GUARDRAIL AROUND HIGH MAST STANDARD. SEE DETAIL SHEET E13 FOR INSTALLATION OF GUARDRAIL IN MEDIAN.
- 9 INSTALL GUARDRAIL AROUND HIGH MAST STANDARD. SEE DETAIL SHEET E13 FOR INSTALLATION OF GUARDRAIL IN GORE AREA.
- 10 CADD FILES GENERATED FROM ORIGINAL PLANS FOR STATE PROJECT 8.1625209 DATED FEBRUARY, 1973.
- 11 REMOVE EXISTING TAPERED GUARDRAIL SECTION. REPLACE WITH NEW STRAIGHT SECTION MAINTAINING SAME OFFSET FROM EOT. SEE STANDARD DRAWING 862.01 SHEET 7 OF 11, DETAIL 1 FOR GUARDRAIL AND ANCHOR UNIT PLACEMENT. SET HIGH MAST FOUNDATION SO THAT EDGE OF STANDARD IS NO MORE THAN 8' BEHIND FACE OF GUARDRAIL.
- 12 ATTACH NEW GUARDRAIL TO STRUCTURE AND EXTEND BEYOND FAR EDGE OF HIGH MAST FOUNDATION. SEE STANDARD DRAWING 862.03, SHEET 1 FOR GUARDRAIL PLACEMENT AND INSTALLATION. SET HIGH MAST FOUNDATION SO THAT EDGE OF STANDARD IS NO MORE THAN 8' BEHIND FACE OF GUARDRAIL.
- 13 PLACE PROPOSED CONTROL SYSTEM NEAR EXISTING C/A FENCE AND OUT OF DITCH LINE. RUN SERVICE LATERAL TO EXISTING SERVICE POLE.
- 14 BORE FEEDER CIRCUIT CONDUIT UNDER SHOULDER AT BOTTOM OF SLOPE PROTECTION.
- 15 STANDARD REMOVED. REMOVE OR ABANDON FOUNDATION AND ASSOCIATED CIRCUITRY AS REQUIRED.

SCOPE OF WORK

RENOVATE ROADWAY LIGHTING SYSTEM BY REPLACING CIRCUITRY, REPLACING CONTROL SYSTEMS, INSTALLING JUNCTION BOXES AND INSTALLING HIGH MAST STANDARDS. ALL EXISTING CONTROL SYSTEMS AND LIGHT STANDARDS TO BE REMOVED.

DESIGN CRITERIA

- 2005 AASHTO ROADWAY LIGHTING DESIGN GUIDE
- 2001 AASHTO STANDARD SPECIFICATIONS FOR STRUCTURAL SUPPORTS FOR HIGHWAY SIGNS, LUMINAIRES, AND TRAFFIC SIGNALS, AND LATEST INTERIM SPECIFICATIONS VALID AT THE TIME OF LETTING
- DESIGN HIGH MOUNT SUPPORT FOR BASIC WIND SPEED OF 90 MPH
- FATIGUE CATEGORY II SHALL BE USED IN DESIGN
- DESIGN HIGH MOUNT STANDARD FOUNDATION FOR BASIC WIND SPEED OF 90 MPH. ANY CONTRACTOR-DESIGNED SITE SPECIFIC FOUNDATION DESIGN SHALL BE DESIGNED FOR THE SAME WIND SPEED
- 2008 NATIONAL ELECTRICAL CODE
- 2002 AASHTO ROADSIDE DESIGN GUIDE

ROADWAY STANDARDS

THE FOLLOWING ROADWAY ENGLISH STANDARDS AS APPEAR IN "NCDOT ROADWAY STANDARD DRAWINGS", ROADWAY DESIGN UNIT-N.C. DEPARTMENT OF TRANSPORTATION RALEIGH, N.C., DATED JULY 2006 ARE APPLICABLE TO THIS PROJECT AND BY REFERENCE HEREBY ARE CONSIDERED A PART OF THESE PLANS:

STD NO.	TITLE
862.01	GUARDRAIL PLACEMENT
862.02	GUARDRAIL INSTALLATION
862.03	STRUCTURE ANCHOR UNITS
865.01	CABLE GUIDERAIL
1401.01	HIGH MOUNT STANDARD
1402.01	HIGH MOUNT FOUNDATION
1403.01	HIGH MOUNT LUMINAIRES
1404.01	LIGHT STANDARDS
1405.01	STANDARD FOUNDATION
1406.01	LIGHT STANDARD LUMINAIRES
1407.01	ELECTRIC SERVICE POLE AND LATERAL
1408.01	LIGHT CONTROL SYSTEM (USE ATTACHED DETAIL SHEET 1408D01 IN LIEU OF STANDARD DRAWING 1408.01 SHEET 2)
1409.01	ELECTRICAL DUCT
1410.01	FEEDER CIRCUITS
1411.01	ELECTRICAL JUNCTION BOXES
1412.01	UNDERPASS LIGHTING

ALL WORK SHALL BE IN CONFORMANCE WITH DIVISIONS 8 AND 14 OF THE STANDARD SPECIFICATIONS FOR ROADS AND STRUCTURES, DATED JULY 2006.

LEGEND

- PROPOSED 80' HIGH MAST STANDARD W/ HM FOUNDATION & (8) HM LUMINAIRES 400W HPS, MEDIUM, CUTOFF, TYPE V
- PROPOSED 100' HIGH MAST STANDARD W/ HM FOUNDATION & (6) HM LUMINAIRES 750W HPS, MEDIUM, CUTOFF, TYPE V
- PROPOSED 120' HIGH MAST STANDARD W/ HM FOUNDATION & (8) HM LUMINAIRES 750W HPS, MEDIUM, CUTOFF, TYPE V
- EXISTING 120' HIGH MAST STANDARD. REMOVE STANDARD AND REMOVE OR ABANDON FOUNDATION AND ASSOCIATED CIRCUITRY.
- EXISTING 100' HIGH MAST STANDARD. REMOVE STANDARD AND REMOVE OR ABANDON FOUNDATION AND ASSOCIATED CIRCUITRY.
- EXISTING 80' HIGH MAST STANDARD. REMOVE STANDARD AND REMOVE OR ABANDON FOUNDATION AND ASSOCIATED CIRCUITRY.
- PROPOSED CONTROL SYSTEM WITH PC36 JUNCTION BOX. BREAKER SIZE SHOWN IN LOAD SCHEDULES.
- EXISTING CONTROL SYSTEM. REMOVE ASSEMBLY AND REMOVE OR ABANDON FOUNDATION AND ASSOCIATED CIRCUITRY.
- PROPOSED ELECTRICAL JUNCTION BOX SEE DETAILS & TABLE B, THIS SHEET
- EXISTING ELECTRICAL JUNCTION BOX. REMOVE.
- EXISTING SINGLE ARM LIGHT STANDARD. REMOVE STANDARD AND REMOVE OR ABANDON FOUNDATION AND ASSOCIATED CIRCUITRY.
- REFERENCE TO CORRESPONDING NOTE AS NUMBERED
- PROPOSED FEEDER CIRCUIT CONTROL SYSTEM(A), CIRCUIT(1) PLAN SYMBOL (6) SEE TABLE A, THIS SHEET
- PROPOSED SERVICE POLE AND LATERAL 30' CLASS 4 3#1/0 USE CONDUCTORS 2" CONDUIT
- PROPOSED ELECTRICAL DUCT SIZE 2", 3", 4" OR 6" TYPE (JA) OR (BD) LOCATION: SEE TABLE C, SHEET E1A

PLAN SYMBOL	DESCRIPTION	CONTRACT ITEM	
8	2 #8 Ø 1 #10G 1.5" P	2 AWG SIZE 8 CONDUCTOR (BK & RD) 1 AWG SIZE 10 GROUNDING CONDUCTOR 1.5" PVC CONDUIT	2 - 8 W/G FEEDER CIRCUIT IN 1.5" CONDUIT
*8	2 #8 Ø 1 #10G	2 AWG SIZE 8 CONDUCTOR (BK & RD) 1 AWG SIZE 10 GROUNDING CONDUCTOR	2 - 8 W/G FEEDER CIRCUIT
6	2 #6 Ø 1 #8G 1.5" P	2 AWG SIZE 6 CONDUCTOR (BK & RD) 1 AWG SIZE 8 GROUNDING CONDUCTOR 1.5" PVC CONDUIT	2 - 6 W/G FEEDER CIRCUIT IN 1.5" CONDUIT
*6	2 #6 Ø 1 #10G	2 AWG SIZE 6 CONDUCTOR (BK & RD) 1 AWG SIZE 8 GROUNDING CONDUCTOR	2 - 6 W/G FEEDER CIRCUIT
4	2 #4 Ø 1 #6G 1.5" P	2 AWG SIZE 4 CONDUCTOR (BK & RD) 1 AWG SIZE 6 GROUNDING CONDUCTOR 1.5" PVC CONDUIT	2 - 4 W/G FEEDER CIRCUIT IN 1.5" CONDUIT
*4	2 #4 Ø 1 #6G	2 AWG SIZE 4 CONDUCTOR (BK & RD) 1 AWG SIZE 6 GROUNDING CONDUCTOR	2 - 4 W/G FEEDER CIRCUIT
2	2 #2 Ø 1 #4G 1.5" P	2 AWG SIZE 2 CONDUCTOR (BK & RD) 1 AWG SIZE 4 GROUNDING CONDUCTOR 1.5" PVC CONDUIT	2 - 2 W/G FEEDER CIRCUIT IN 1.5" CONDUIT
*2	2 #2 Ø 1 #4G	2 AWG SIZE 2 CONDUCTOR (BK & RD) 1 AWG SIZE 4 GROUNDING CONDUCTOR	2 - 2 W/G FEEDER CIRCUIT
1	2 #1 Ø 1 #2G 1.5" P	2 AWG SIZE 1 CONDUCTOR (BK & RD) 1 AWG SIZE 2 GROUNDING CONDUCTOR 1.5" PVC CONDUIT	2 - 1 W/G FEEDER CIRCUIT IN 1.5" CONDUIT
*1	2 #1 Ø 1 #2G	2 AWG SIZE 1 CONDUCTOR (BK & RD) 1 AWG SIZE 2 GROUNDING CONDUCTOR	2 - 1 W/G FEEDER CIRCUIT

TRADE SIZE	METRIC	ENGLISH
1/2	16mm	1/2"
3/4	21mm	3/4"
1	27mm	1"
1.5	41mm	1 1/2"
2	53mm	2"
3	78mm	3"

BD	BURIED	PVC	PVC SCHEDULE 40 CONDUIT
LT	LIGHT	RGC	RIGID GALVANIZED STEEL CONDUIT
JA	JACKED	C	CONDUIT
MH	MOUNTING HEIGHT	CKT	CIRCUIT
Ø	PHASE	N	NEUTRAL
SER LAT	SERVICE LATERAL	G	GROUND
NTS	NOT TO SCALE	HM	HIGH MAST

COMPUTED BY: RGH DATE: 12/16/09
 CHECKED BY: Jay A. Smith DATE: 12-16-09

16-DEC-2009 11:36
 t:\projects\1-40_catawba county\catawba tracing\catawba_co.le.psh-el.dgn
 \$\$\$USERNAME\$\$\$

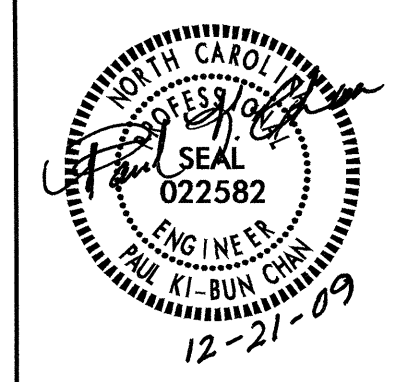

**TABLE "C"
ELECTRICAL DUCT SUMMARY
(ESTIMATED LENGTH IN FEET)**

LOCATION	RACEWAY	SHEET	CONTROL SYSTEM	TYPE				
				JACKED (JA) FEET			BURIED (BD) FEET	
				SIZE 3"	SIZE 4"	SIZE 6"	SIZE 2"	SIZE 3"
CSA TO JB1		E3	A			40		
	CSA TO JB1	E3	A					115
JB1-JB10, NB CD RAMP		E3	A			40		
JB1-JB10, NB US321		E3	A			45		
	JB1-JB10	E3	A					180
JB10-JB11, SB US321		E3	A			45		
JB10-JB11, SB CD RAMP		E3	A			30		
	JB10-JB11	E3	A					180
JB26-JB27		E3	A	45				
JB27-JB28		E3	A	45				
JB3-JB4		E4	A	35				
JB20-JB21, CD RAMP, WB I-40		E4	A	35				
JB20-JB21, WB I-40		E4	A	45				
JB13-JB14		E4	A	35				
JB18-JB20		E4	AA	30				
JB18-JB19		E4	AA	35				
JB11-JB12		E4	AA	35				
JB31-JB32		E4	AA	35				
JB23-JB24, CD RAMP, EB I-40		E4	AA	35				
JB23-JB24, EB I-40		E4	AA	45				
JB25-JB26		E4	AA	45				
JB26-JB27		E4	AA	75				
CSAA-JB1		E5	AA			40		
	CSAA-JB1	E5	AA					90
JB8-JB9, CD RAMP NB		E5	AA		35			
JB8-JB9, NB US321		E5	AA		50			
JB9-JB10, SB US321		E5	AA		50			
JB9-JB10, CD RAMP SB		E5	AA		25			
	JB8-JB10	E5	AA					320
JB2-JB3		E5	AA	35				
JB4-JB7		E5	AA	70				
TOP OF I-40 EB EXIT RAMP		E7	B			50		
	JB1-JB2	E7	B					100
I-40 EB LOOP		E7	B			30		
	JB2-JB3	E7	B					80
I-40 EB NEAR OVERPASS		E7	B			60		
	JB5-JB6	E7	B					85
I-40 WB NEAR OVERPASS		E7	B	50				
LENOIR RHYNE BLVD.		E7	B	80				
JB1-JB2, I-40 EB		E9	C		50			
	JB5-JB6	E9	C					100
JB8-JB9, I-40 WB		E9	C	55				
JB4-JB5, I-40 EB		E9	C	55				
I-40 EB ENTRANCE RAMP		E10	D		50			
	JB15-JB1	E10	D					85
I-40 EB NEAR OVERPASS		E10	D		60			
	JB3-JB4	E10	D					95
I-40 WB NEAR OVERPASS		E10	D	60				
I-40 EB ENTRANCE RAMP		E11	E		75			
	JB1-JB2	E11	E					120
I-40 EB NEAR OVERPASS		E11	E		55			
I-40 WB NEAR OVERPASS		E11	E		60			
	JB4-JB5	E11	E					215
JB7-JB8, I-40 WB LOOP		E11	E	30				
JB8-JB9, I-40 EB LOOP		E11	E		30			
	JB9-JB10	E11	E					60
JB13-JB14, I-40 EB		E11	E	65				
TOTALS:				1075	465	455	875	950

**CONTROL SYSTEM "A"
TABLE "B"
JUNCTION BOX SUMMARY**

NUMBER	TYPE	SHEET
JB1	PC36	E3
JB2	PC18	E4
JB3	PC18	E4
JB4	PC18	E4
JB5	PC18	E4
JB6	PC18	E4
JB7	PC18	E4
JB8	PC18	E4
JB9	PC18	E4
JB10	PC36	E3
JB11	PC36	E3
JB12	PC36	E4
JB13	PC18	E4
JB14	PC18	E4
JB15	PC18	E4
JB16	PC18	E4
JB17	PC18	E4
JB18	PC18	E4
JB19	PC18	E4
JB20	PC18	E4
JB21	PC18	E4
JB22	PC18	E2
JB23	PC18	E2
JB24	PC18	E2
JB25	PC18	E2
JB26	PC18	E3
JB27	PC18	E3
JB28	PC18	E3
JB29	PC18	E3
JB30	PC18	E3
JB31	PC18	E4
TOTALS	27	4

**CONTROL SYSTEM "AA"
TABLE "B"
JUNCTION BOX SUMMARY**

NUMBER	TYPE	SHEET
JB1	PC36	E5
JB2	PC18	E5
JB3	PC18	E5
JB4	PC18	E5
JB5	PC18	E5
JB6	PC18	E5
JB7	PC18	E5
JB8	PC36	E5
JB9	PC36	E5
JB10	PC36	E5
JB11	PC18	E4
JB12	PC18	E4
JB13	PC18	E4
JB14	PC18	E5
JB15	PC18	E5
JB16	PC18	E4
JB17	PC18	E4
JB18	PC18	E4
JB19	PC18	E4
JB20	PC18	E4
JB21	PC18	E5
JB22	PC18	E4
JB23	PC18	E4
JB24	PC18	E4
JB25	PC18	E4
JB26	PC18	E4
JB27	PC18	E4
JB28	PC18	E6
JB29	PC18	E6
JB30	PC18	E6
JB31	PC18	E4
JB32	PC18	E4
JB33	PC18	E4
JB34	PC18	E4
JB35	PC18	E2
TOTALS	31	4

**CONTROL SYSTEM "B"
TABLE "B"
JUNCTION BOX SUMMARY**

NUMBER	TYPE	SHEET
JB1	PC36	E7
JB2	PC36	E7
JB3	PC36	E7
JB4	PC36	E7
JB5	PC36	E7
JB6	PC36	E7
JB7	PC18	E7
JB8	PC18	E7
JB9	PC18	E7
JB10	PC18	E7
JB11	PC18	E7
JB12	PC18	E7
JB13	PC18	E7
JB14	PC18	E7
JB15	PC18	E7
JB16	PC18	E7
JB17	PC18	E7
JB18	PC18	E7
JB19	PC18	E7
JB20	PC18	E7
JB21	PC18	E5
JB22	PC18	E4
JB23	PC18	E4
JB24	PC18	E4
TOTALS	17	6

**CONTROL SYSTEM "C"
TABLE "B"
JUNCTION BOX SUMMARY**

NUMBER	TYPE	SHEET
JB1	DELETED	E9
JB2	PC36	E9
JB3	PC18	E9
JB4	PC18	E9
JB5	PC18	E9
JB6	PC18	E9
JB7	PC18	E9
JB8	PC18	E9
JB9	PC18	E9
JB10	PC18	E9
JB11	PC18	E9
TOTALS	9	1

**CONTROL SYSTEM "D"
TABLE "B"
JUNCTION BOX SUMMARY**

NUMBER	TYPE	SHEET
JB1	PC36	E10
JB2	PC36	E10
JB3	PC36	E10
JB4	PC36	E10
JB5	PC18	E10
JB6	PC18	E10
JB7	PC18	E10
JB8	PC18	E10
JB9	PC18	E10
JB10	PC18	E10
JB11	PC18	E10
JB12	PC36	E10
JB13	PC18	E10
JB14	PC18	E10
JB15	PC36	E10
TOTALS	10	5

**CONTROL SYSTEM "E"
TABLE "B"
JUNCTION BOX SUMMARY**

NUMBER	TYPE	SHEET
JB1	PC36	E11
JB2	PC36	E11
JB3	PC36	E11
JB4	PC18	E11
JB5	PC18	E11
JB6	PC18	E11
JB7	PC18	E11
JB8	PC18	E11
JB9	PC18	E11
JB10	PC18	E11
JB11	PC18	E11
JB12	PC36	E11
JB13	PC18	E11
JB14	PC18	E11
JB15	PC18	E11
TOTALS	12	3

16-DEC-2009 11:36
 t:\projects\1-40_catawba county\catawba tracing\catawba_co_le_psh_ei.dgn
 \$\$\$USERNAME\$\$\$

02/03/98

I:\DEC-2009\15133\ad-stancil\projects\1-40, catawba county\catawba tracing\exit 123\us321_le_psh_e2.dgn
\$\$\$\$SUBSERIALNAME\$\$\$\$

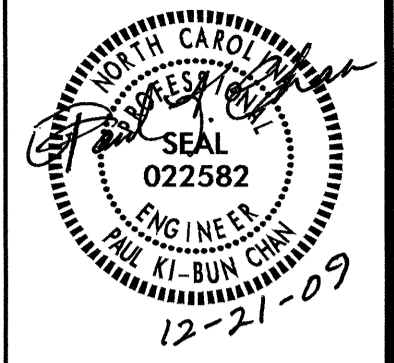
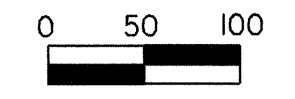

USE FOR LIGHTING CONSTRUCTION ONLY

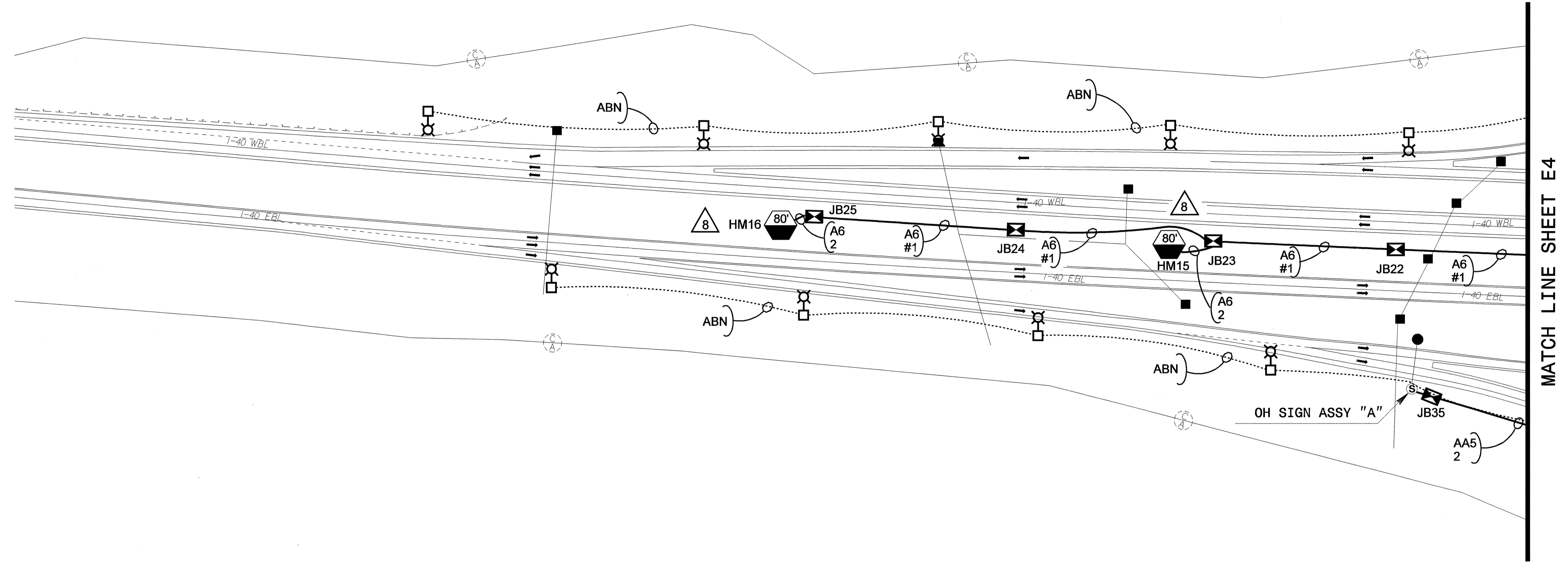

MATCH LINE SHEET E4

SEE SHEET "E1" FOR
LEGEND & △ NOTES

2			
1			
Rev.	Date	Description	Approved
NORTH CAROLINA DEPARTMENT OF TRANSPORTATION ROADWAY DESIGN LIGHTING/ELECTRICAL SECTION LIGHTING LAYOUT I-40/ US-321 INTERCHANGE CATAWBA COUNTY			
Drawn By:	JAS	Approved By:	<i>[Signature]</i>
Dwg No.:			

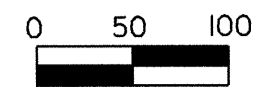
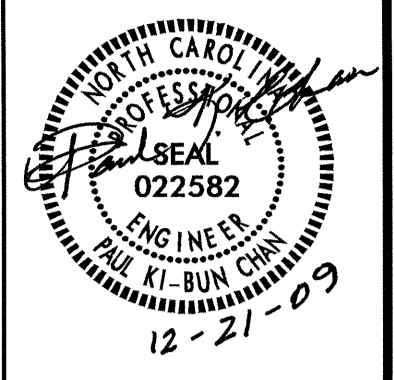

USE FOR LIGHTING CONSTRUCTION ONLY

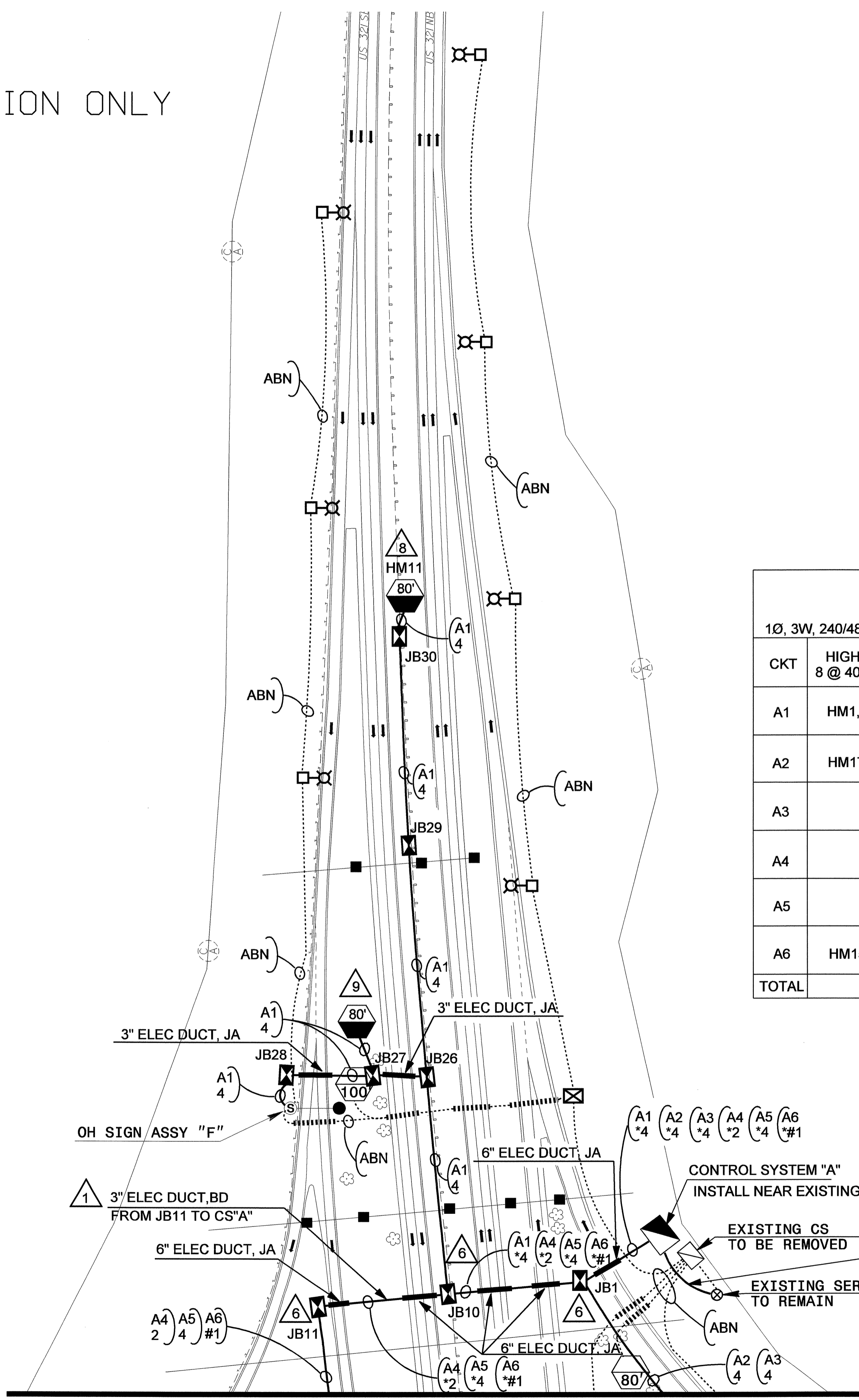
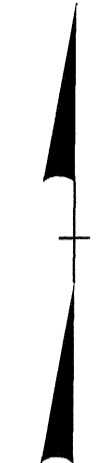

LOAD SCHEDULE I-40/ US-321 NE						
1Ø, 3W, 240/480 VAC			CONTROL SYSTEM "A"			
CKT	HIGH MAST 8 @ 400W HPS	HIGH MAST 8 @ 750W HPS	OVERHEAD SIGNS	AMPS @ 480V	KW LOAD	BREAKER SIZE (AMPS)
A1	HM1, HM2		F	19.7	9.46	25
A2	HM17, HM18			16.0	7.68	20
A3		HM19		14.4	6.91	20
A4		HM13	G, X	21.4	10.27	30
A5		HM14		14.4	6.91	20
A6	HM15, HM16			16.0	7.68	20
TOTAL	6	3	3	101.9	48.91	

MATCH LINE SHEET E4

SEE SHEET "E1" FOR
LEGEND & △ NOTES

2			
1			
Rev.	Date	Description	Approved
NORTH CAROLINA DEPARTMENT OF TRANSPORTATION ROADWAY DESIGN LIGHTING/ELECTRICAL SECTION LIGHTING LAYOUT I-40/ US-321 INTERCHANGE CATAWBA COUNTY			
Drawn By:	JAS	Approved By:	<i>[Signature]</i>
Dwg No.:			

I6-DEC-2009 11:17
 \\140-catawba-county\catwba-tracing\exit 123\us321-le-psh-e3.dgn
 \$\$\$USERNAME\$\$\$

02/03/98

USE FOR LIGHTING CONSTRUCTION ONLY

MATCH LINE SHEET E3

0 50 100

PROJECT REFERENCE NO. 1-5143 SHEET NO. E4

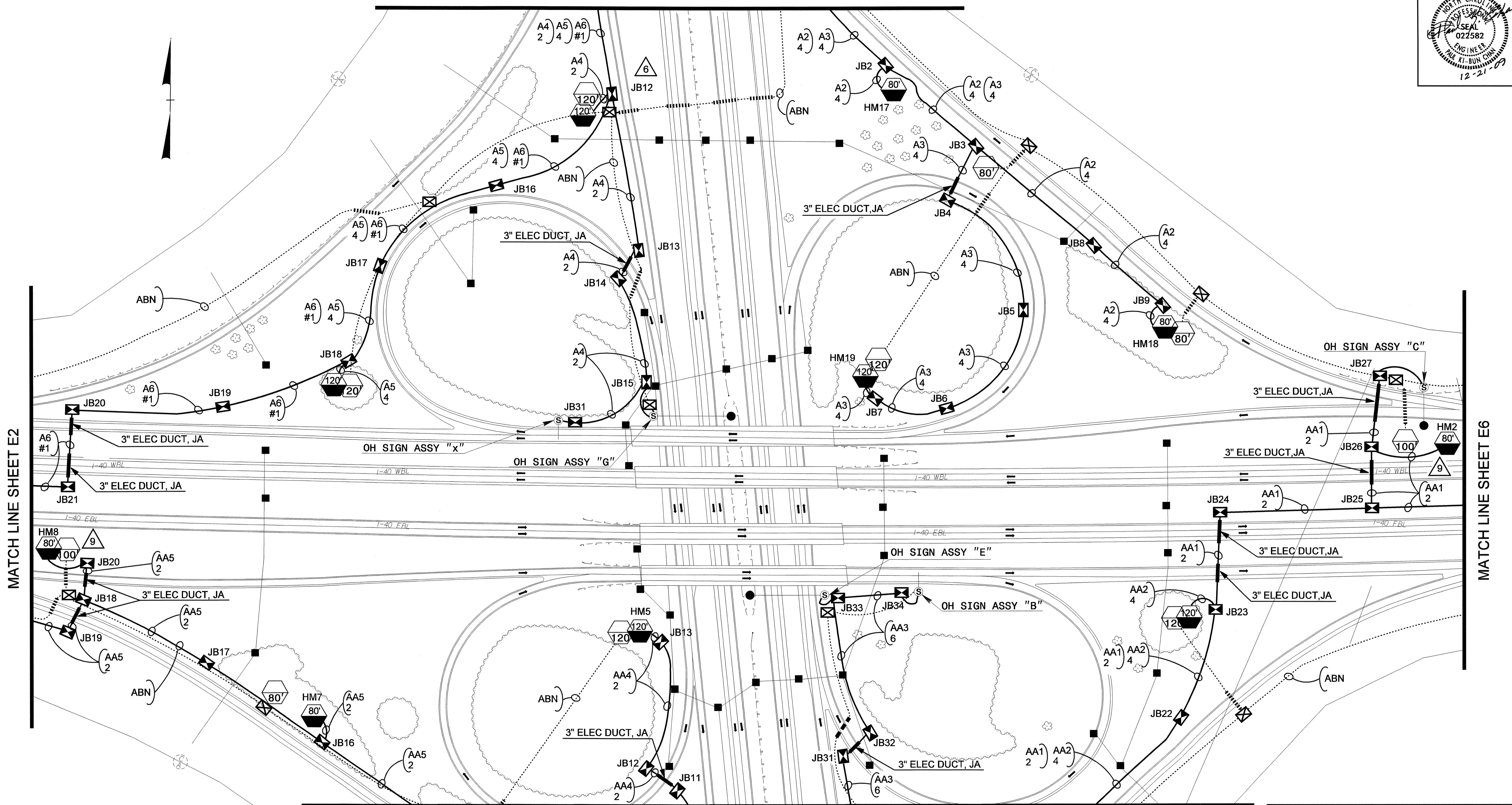

MATCH LINE SHEET E2

MATCH LINE SHEET E6

MATCH LINE SHEET E5

16-DEC-2009 11:17 I:_S\catowba county\catowba tracing\exit 123\us321.le.psh-e4.dgn

2			
1			
Rev.	Date	Description	Approved
NORTH CAROLINA DEPARTMENT OF TRANSPORTATION ROADWAY DESIGN LIGHTING/ELECTRICAL SECTION LIGHTING LAYOUT I-40/ US-321 INTERCHANGE CATAWBA COUNTY			
Drawn By:	JAS	Approved By:	[Signature]
Dwg No.:			

SEE SHEET "E1" FOR LEGEND & △ NOTES

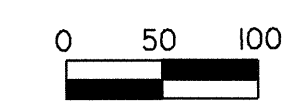

USE FOR LIGHTING CONSTRUCTION ONLY

MATCH LINE SHEET E4

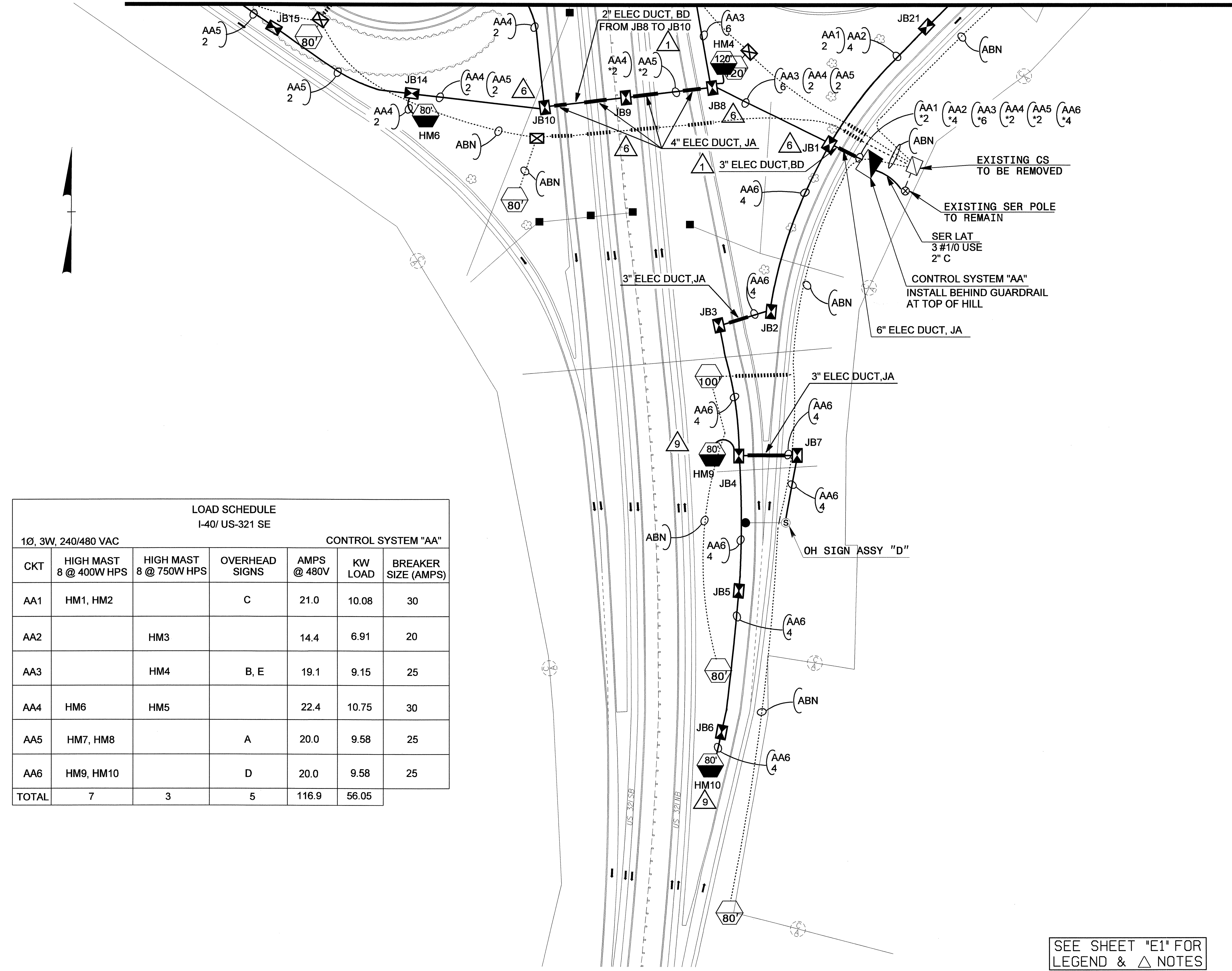
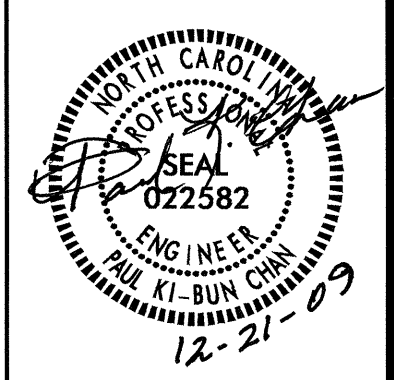

LOAD SCHEDULE I-40/ US-321 SE						
1Ø, 3W, 240/480 VAC			CONTROL SYSTEM "AA"			
CKT	HIGH MAST 8 @ 400W HPS	HIGH MAST 8 @ 750W HPS	OVERHEAD SIGNS	AMPS @ 480V	KW LOAD	BREAKER SIZE (AMPS)
AA1	HM1, HM2		C	21.0	10.08	30
AA2		HM3		14.4	6.91	20
AA3		HM4	B, E	19.1	9.15	25
AA4	HM6	HM5		22.4	10.75	30
AA5	HM7, HM8		A	20.0	9.58	25
AA6	HM9, HM10		D	20.0	9.58	25
TOTAL	7	3	5	116.9	56.05	

SEE SHEET "E1" FOR
LEGEND & △ NOTES

2			
1			
Rev.	Date	Description	Approved
NORTH CAROLINA DEPARTMENT OF TRANSPORTATION ROADWAY DESIGN LIGHTING/ELECTRICAL SECTION LIGHTING LAYOUT I-40/ US-321 INTERCHANGE CATAWBA COUNTY			
Drawn By: JAS	Approved By: <i>[Signature]</i>	Dwg No.:	

16-DEC-2009 11:16:40 c:\atawba county\tracing\exit 123\us321.le.psh.e5.dgn
 \$\$\$USE NAME \$\$\$

02/03/98

02/03/98

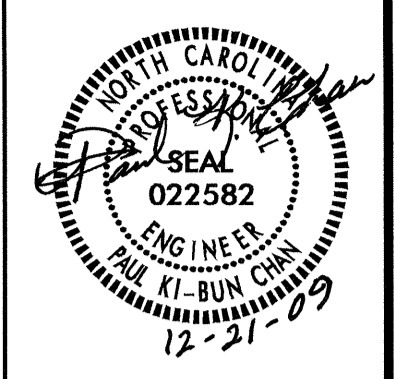
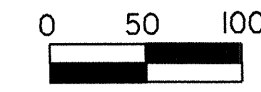

USE FOR LIGHTING CONSTRUCTION ONLY

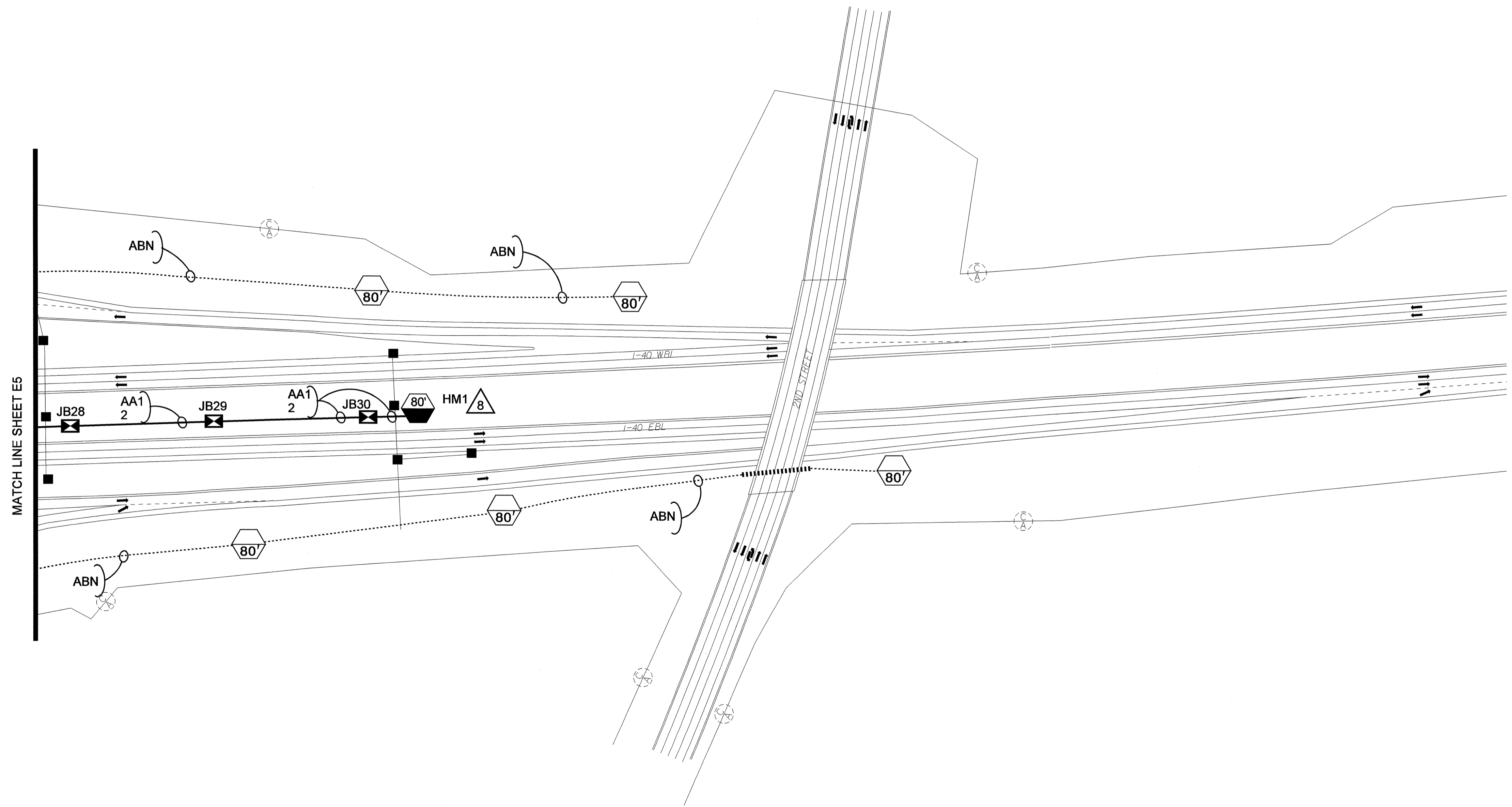
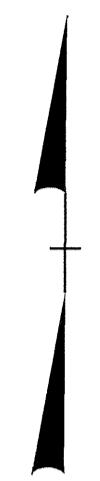

I:\DEC-2009\1537\14\edit\14\ecad-stencil\projects\1-40, catawba county\catawba tracing\exit 123\us321.le.psh.e6.dgn
 \$\$\$USERNAME\$\$\$

SEE SHEET "E1" FOR
 LEGEND & △ NOTES

2			
1			
Rev.	Date	Description	Approved
NORTH CAROLINA DEPARTMENT OF TRANSPORTATION ROADWAY DESIGN LIGHTING/ELECTRICAL SECTION LIGHTING LAYOUT I-40/ US-321 INTERCHANGE CATAWBA COUNTY			
Drawn By:	Approved By:	Drawn No.:	
JAS			

USE FOR LIGHTING CONSTRUCTION ONLY

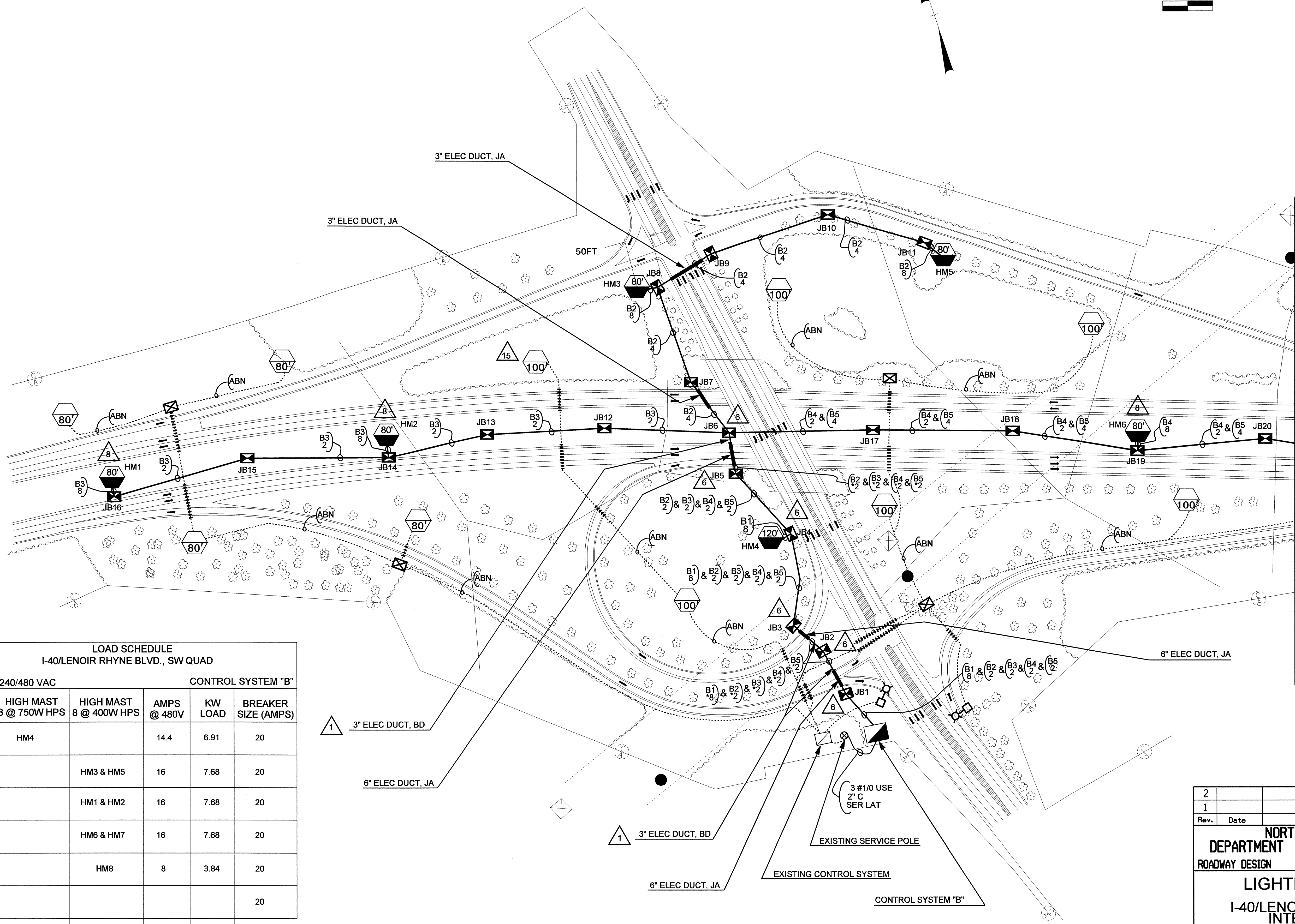
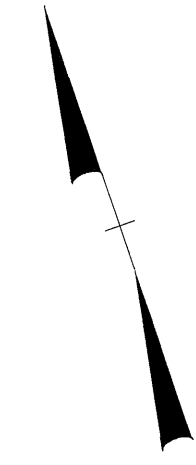
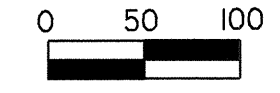
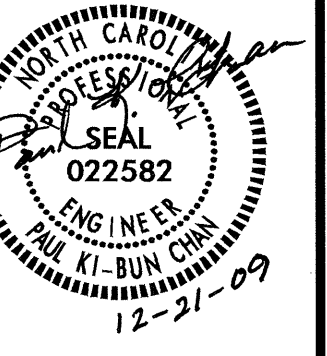

LOAD SCHEDULE
I-40/LENOIR RHYNE BLVD., SW QUAD

CKT	1Ø, 3W, 240/480 VAC		CONTROL SYSTEM "B"		
	HIGH MAST 8 @ 750W HPS	HIGH MAST 8 @ 400W HPS	AMPS @ 480V	KW LOAD	BREAKER SIZE (AMPS)
B1	HM4		14.4	6.91	20
B2		HM3 & HM5	16	7.68	20
B3		HM1 & HM2	16	7.68	20
B4		HM6 & HM7	16	7.68	20
B5		HM8	8	3.84	20
SPARE					20
TOTAL	1	7	70.4	33.79	

MATCHLINE SHEET E8

2			
1			
Rev.	Date	Description	Approved
NORTH CAROLINA DEPARTMENT OF TRANSPORTATION ROADWAY DESIGN LIGHTING/ELECTRICAL SECTION LIGHTING LAYOUT I-40/LENOIR RHYNE BLVD. INTERCHANGE CATAWBA COUNTY			
Drawn By:	AB	Approved By:	[Signature]
		Dwg No.:	

21-DEC-2009 15:37 t:\projects\1-40_catawba county\catawba tracing\exit 125\exit.125_le.psh_e7.dgn \$\$\$USERNAME\$\$\$

USE FOR LIGHTING CONSTRUCTION ONLY

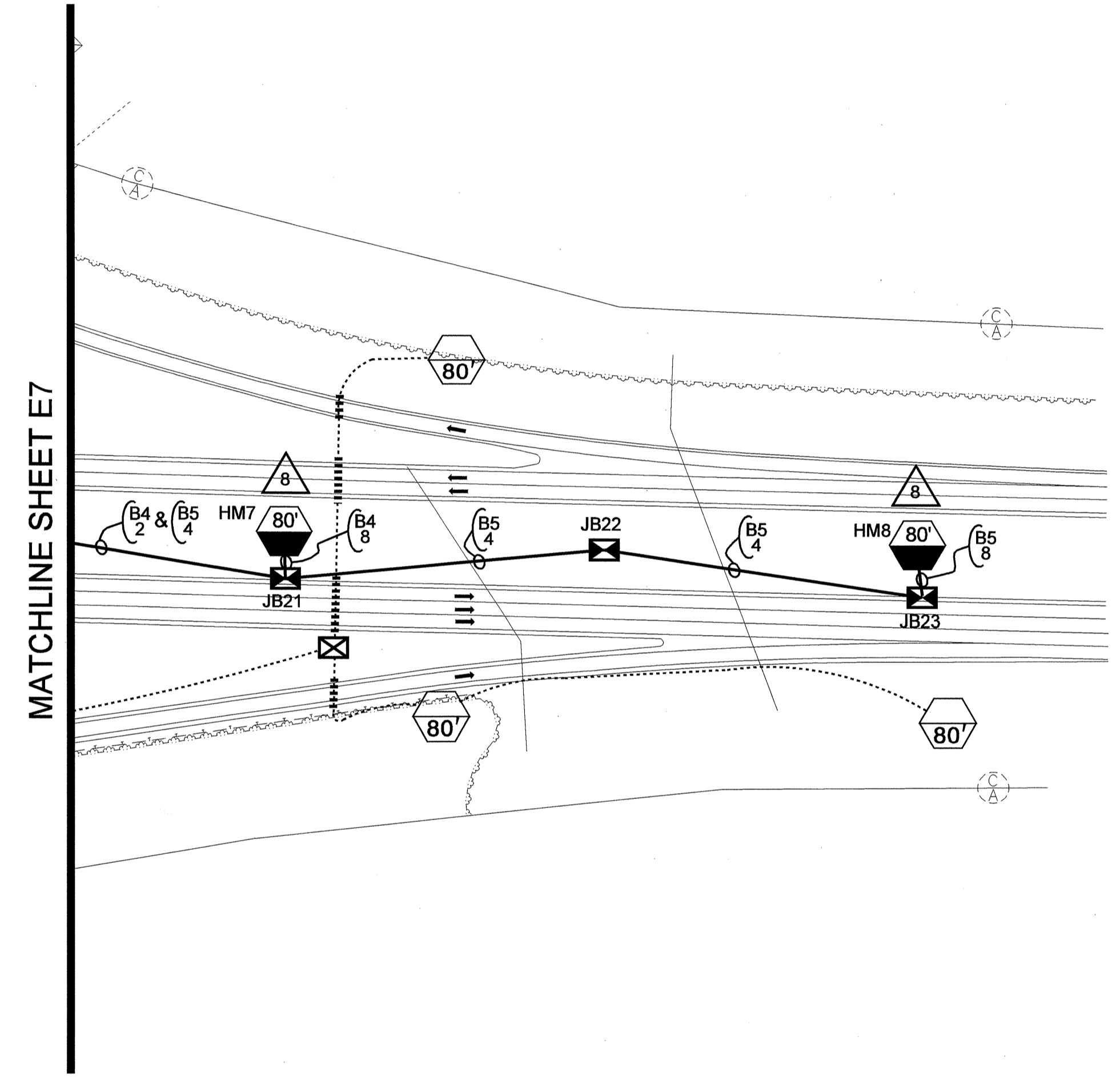
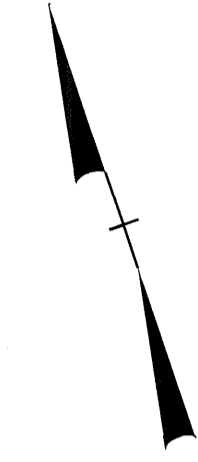
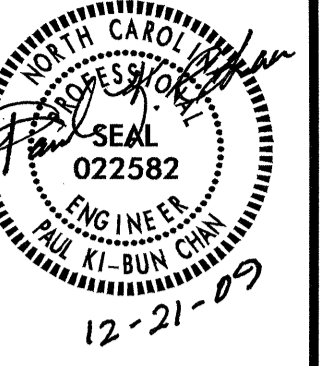
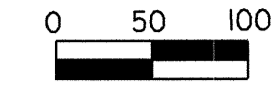

16-DEC-2009 09:08
 t:\projects\1-40\catawba county\catawba tracing\exit 125\exit.125.le_psh_e8.dgn
 \$\$\$USERNAME\$\$\$

Rev.	Date	Description	Approved
2			
1			

NORTH CAROLINA
DEPARTMENT OF TRANSPORTATION
 ROADWAY DESIGN LIGHTING/ELECTRICAL SECTION

LIGHTING LAYOUT
I-40/LENOIR RHYNE BLVD.
INTERCHANGE

CATAWBA COUNTY

Drawn By:	Approved By:	Dwg No.:
AB		

USE FOR LIGHTING CONSTRUCTION ONLY

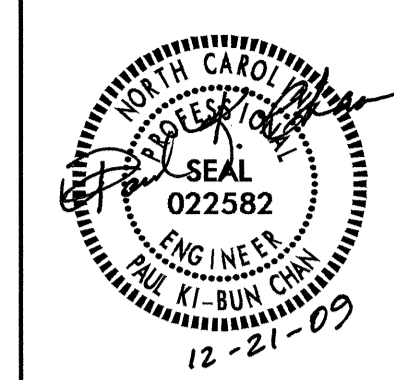
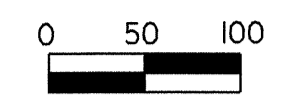

SEE SHEET "E1" FOR
LEGEND & Δ NOTES

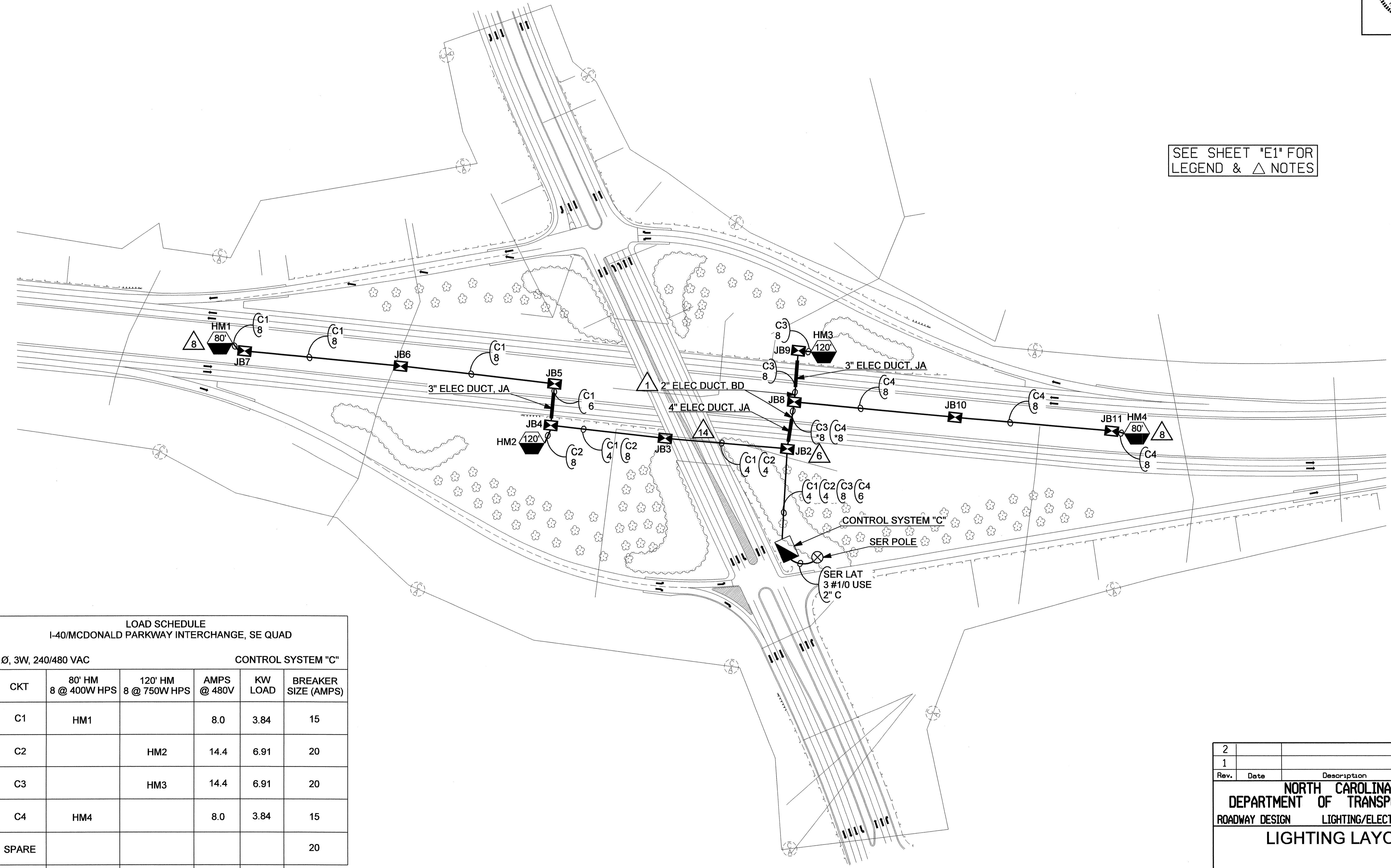

LOAD SCHEDULE I-40/MCDONALD PARKWAY INTERCHANGE, SE QUAD					
1Ø, 3W, 240/480 VAC			CONTROL SYSTEM "C"		
CKT	80' HM 8 @ 400W HPS	120' HM 8 @ 750W HPS	AMPS @ 480V	KW LOAD	BREAKER SIZE (AMPS)
C1	HM1		8.0	3.84	15
C2		HM2	14.4	6.91	20
C3		HM3	14.4	6.91	20
C4	HM4		8.0	3.84	15
SPARE					20
	2	2	44.8	21.5	

2			
1			
Rev.	Date	Description	Approved
NORTH CAROLINA DEPARTMENT OF TRANSPORTATION ROADWAY DESIGN LIGHTING/ELECTRICAL SECTION LIGHTING LAYOUT I-40/MCDONALD PARKWAY INTERCHANGE CATAWBA COUNTY			
Drawn By	RGH	Approved By	[Signature]
Dwg No.			

21-DEC-2009 15:34
 t:\projects\I-40\catawba county\catawba tracing\exit 126\exit.126.le.psh_e9.dgn
 \$\$\$USERNAME\$\$\$

02/03/98

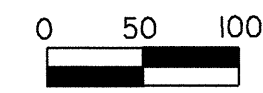

USE FOR LIGHTING CONSTRUCTION ONLY

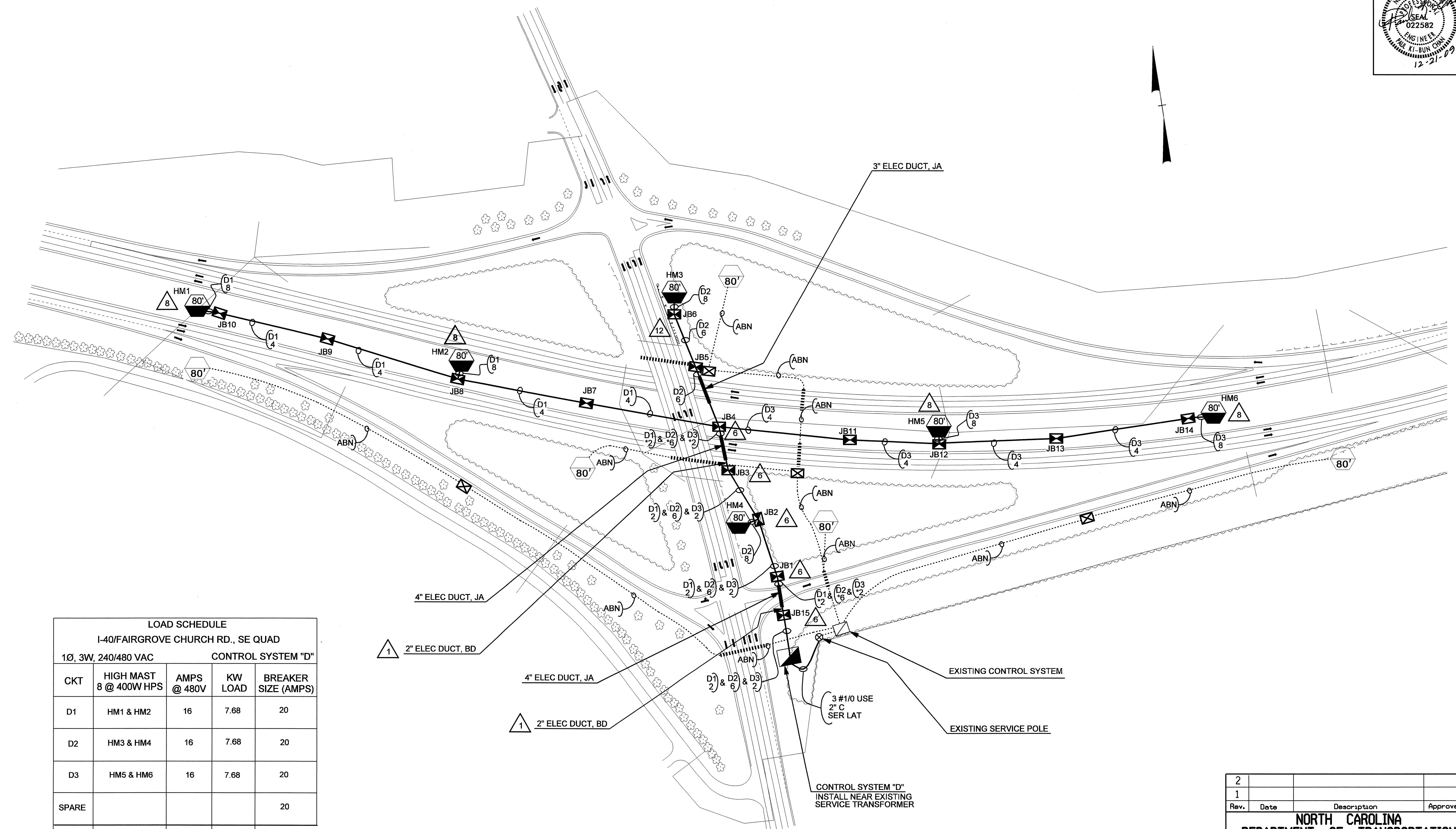

LOAD SCHEDULE
I-40/FAIRGROVE CHURCH RD., SE QUAD
CONTROL SYSTEM "D"

CKT	HIGH MAST 8 @ 400W HPS	AMPS @ 480V	KW LOAD	BREAKER SIZE (AMPS)
D1	HM1 & HM2	16	7.68	20
D2	HM3 & HM4	16	7.68	20
D3	HM5 & HM6	16	7.68	20
SPARE				20
TOTAL	6	48	23.1	

SEE SHEET "E1" FOR
LEGEND & △ NOTES

2			
1			
Rev.	Date	Description	Approved
NORTH CAROLINA DEPARTMENT OF TRANSPORTATION ROADWAY DESIGN LIGHTING/ELECTRICAL SECTION LIGHTING LAYOUT FAIRGROVE CHURCH RD./I-40 EXIT 128 X COUNTY			
Drawn By:	AB	Approved By:	<i>[Signature]</i>

I6-DEC-2009 10:02
 I:\projects\2009\128\15143-exit128.le_psh.dgn
 \$\$\$BUSSENAME\$\$\$

USE FOR LIGHTING CONSTRUCTION ONLY

SEE SHEET "E1" FOR LEGEND & △ NOTES

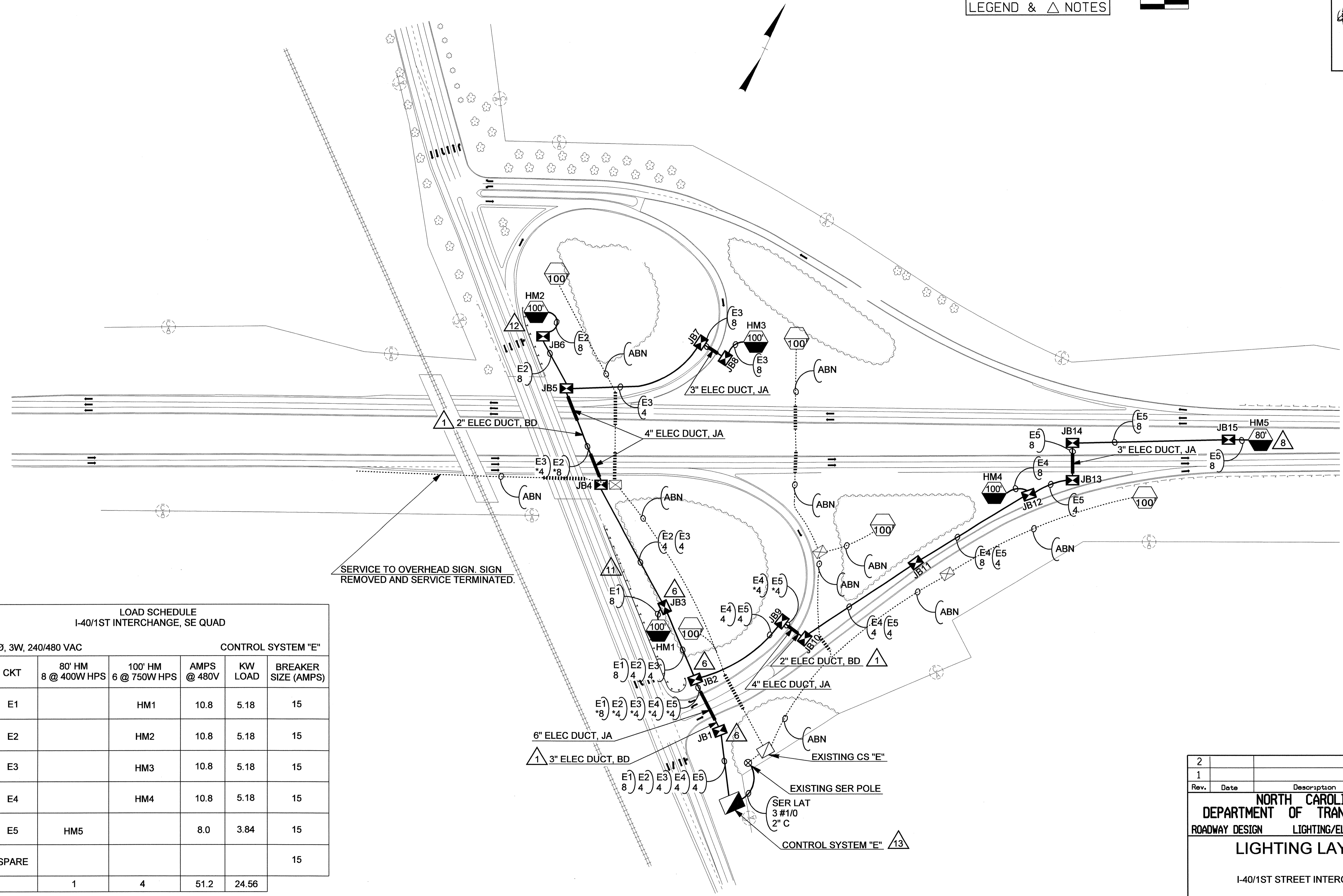
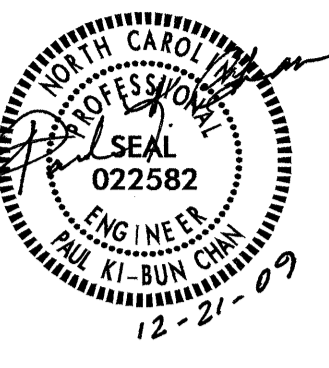
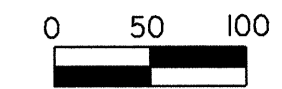

LOAD SCHEDULE
I-40/1ST INTERCHANGE, SE QUAD

1Ø, 3W, 240/480 VAC		CONTROL SYSTEM "E"			
CKT	80' HM 8 @ 400W HPS	100' HM 6 @ 750W HPS	AMPS @ 480V	KW LOAD	BREAKER SIZE (AMPS)
E1		HM1	10.8	5.18	15
E2		HM2	10.8	5.18	15
E3		HM3	10.8	5.18	15
E4		HM4	10.8	5.18	15
E5	HM5		8.0	3.84	15
SPARE					15
	1	4	51.2	24.56	

2				
1				
Rev.	Date	Description	Approved	
NORTH CAROLINA DEPARTMENT OF TRANSPORTATION ROADWAY DESIGN LIGHTING/ELECTRICAL SECTION LIGHTING LAYOUT I-40/1ST STREET INTERCHANGE CATAWBA COUNTY Drawn By: RGH Approved By: [Signature] Deg No.:				

21-DEC-2009 15:31
 t:\projects\1-40\catawba county\catawba tracing\exit 130\exit_130_le_psh_e11.dgn
 \$\$\$USERNAME\$\$\$

02/03/98

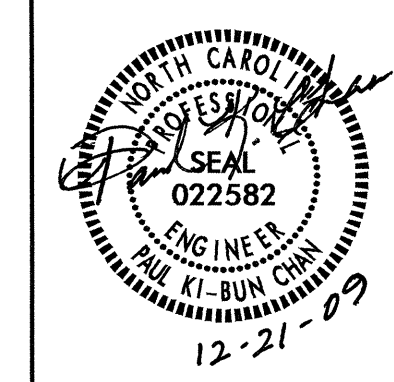

USE FOR LIGHTING CONSTRUCTION ONLY

STATE OF NORTH CAROLINA DEPT. OF TRANSPORTATION DIVISION OF HIGHWAYS RALEIGH, N.C. 7-06 ENGLISH STANDARD DRAWING FOR LIGHT CONTROL SYSTEM ASSEMBLY SHEET 2 OF 3 1408D01

- NOTES**
- △ CURRENT TRANSFORMER (CT) CABINET AND METER MAY BE MOUNTED ON SERVICE POLE OR BACK OF CONTROL ENCLOSURE.
 - △ SEE SECTION 1407 OF THE STANDARD SPECIFICATIONS FOR SERVICE POLE AND SERVICE LATERAL.
 - △ SEE PLANS FOR SIZE OF CONDUITS AND/OR ELECTRICAL DUCT.
 - △ STUB FEEDER CIRCUIT CONDUITS INTO JUNCTION BOX. CAP UNUSED CONDUITS. FEEDER CIRCUITS MUST BE MINIMUM 30" BELOW GRADE.
 - △ SEE SECTION 1411 OF THE STANDARD SPECIFICATIONS FOR JUNCTION BOX INSTALLATION.

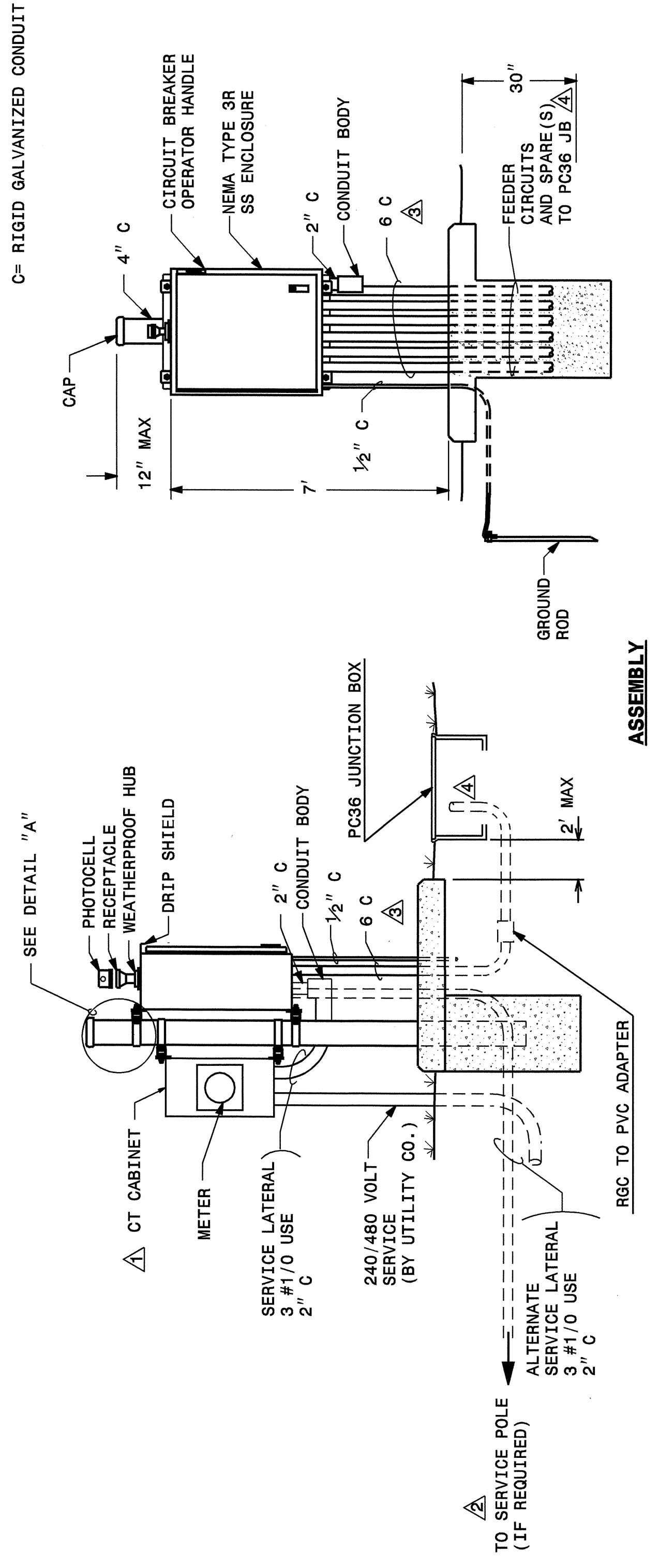
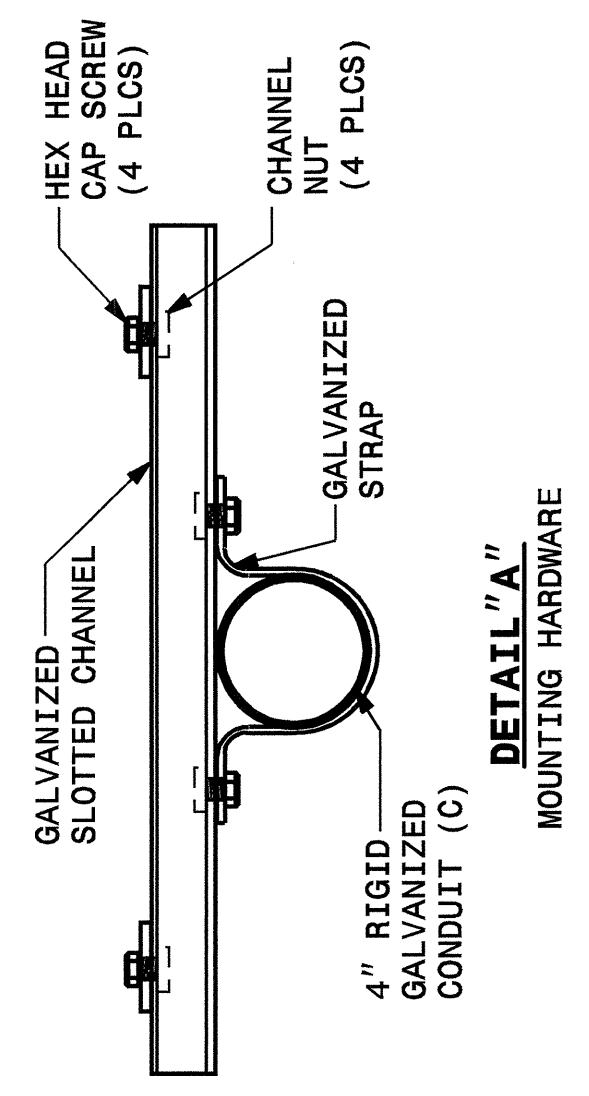

STATE OF NORTH CAROLINA DEPT. OF TRANSPORTATION DIVISION OF HIGHWAYS RALEIGH, N.C. 7-06 ENGLISH STANDARD DRAWING FOR LIGHT CONTROL SYSTEM ASSEMBLY SHEET 2 OF 3 1408D01

Rev.	Date	Description	Approved
2			
1			

NORTH CAROLINA DEPARTMENT OF TRANSPORTATION ROADWAY DESIGN LIGHTING/ELECTRICAL SECTION

LIGHT CONTROL ASSEMBLY SPECIAL DETAILS

Drawn By: RGH Approved By: [Signature] Dwg No.:

15-DEC-2009 14:38 t:\projects\1-401\catawba county\catawba tracing\catawba-co-dtl_psh_e12.dgn \$\$\$USERNAME\$\$\$ 02/03/98

NTS

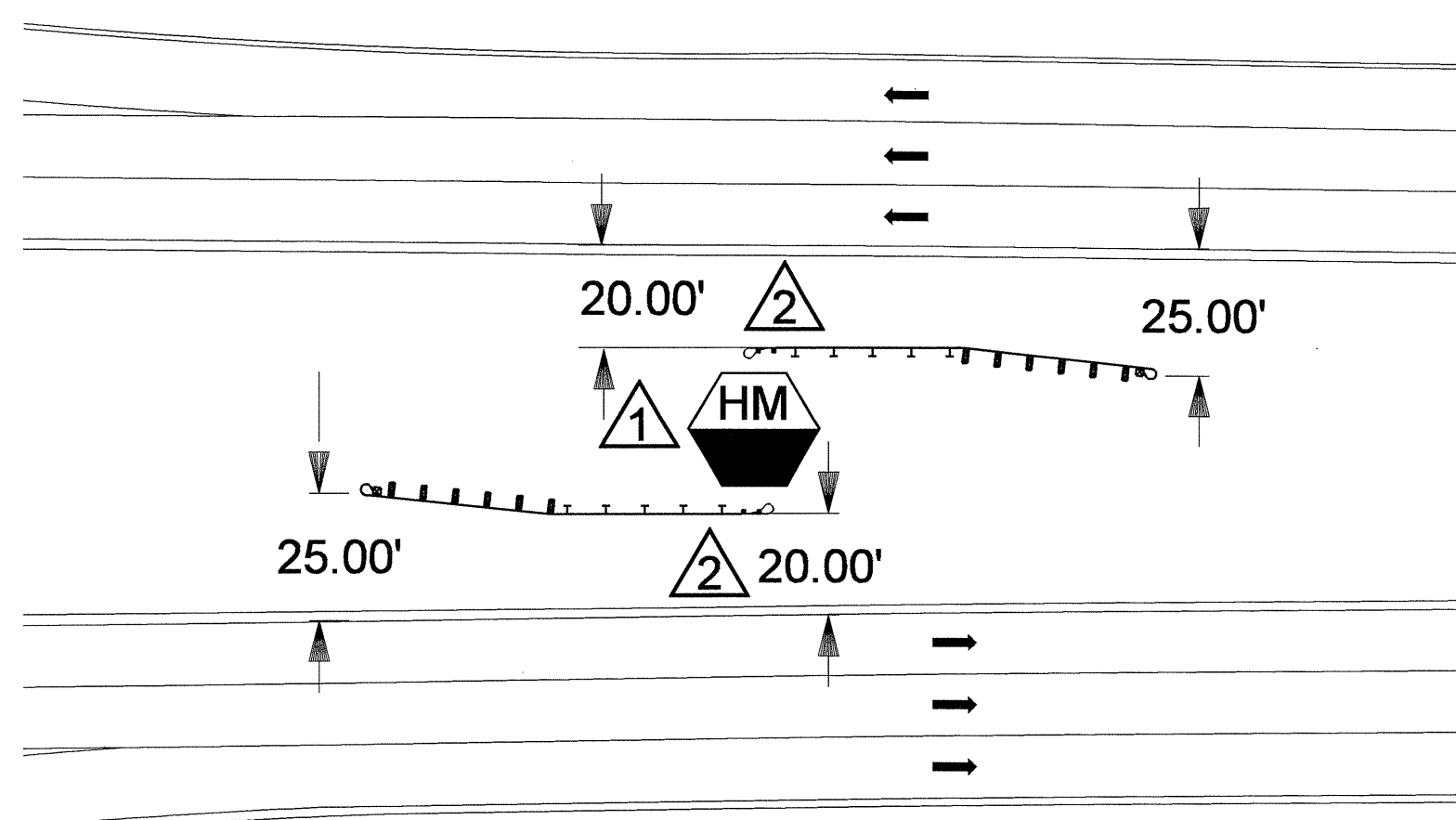
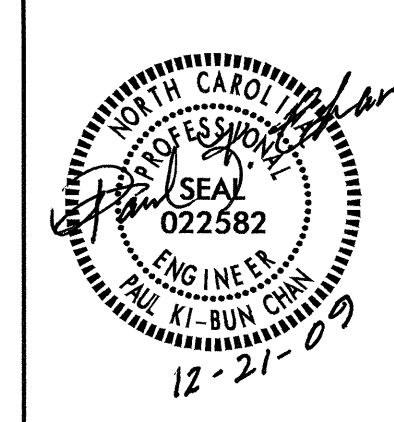

MEDIAN GR INVENTORY SUMMARY (PER SIDE)

- 1 M-350 BEGIN UNITS
- 3 12.5' RIGID GUARDRAIL UNITS
- 1 CAT-1

MEDIAN GUARDRAIL INSTALLATION TYPICAL DETAILS

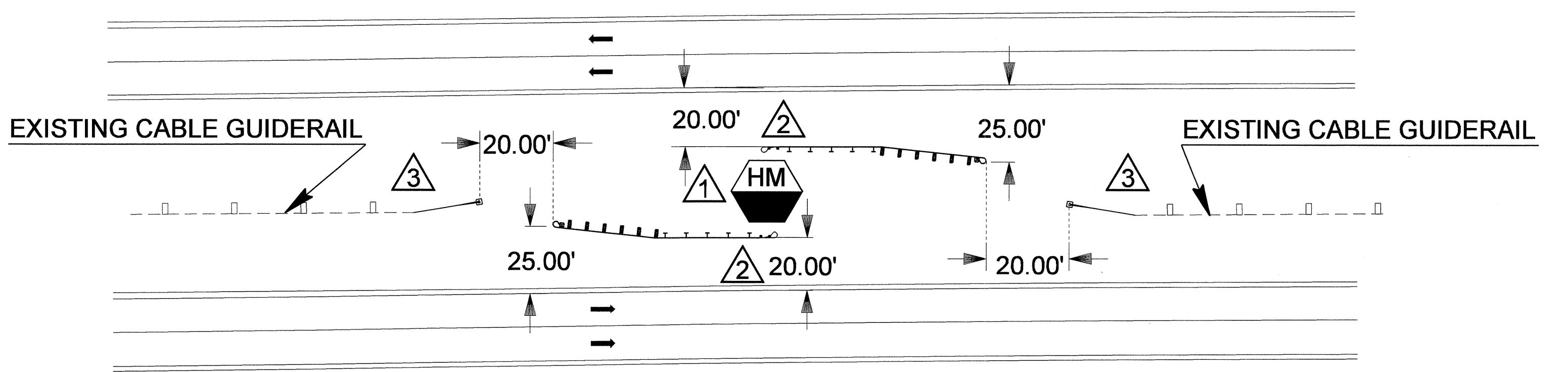

**MEDIAN GR INVENTORY SUMMARY (PER SIDE)
(WITH EXISTING CABLE GUIDERAIL)**

- 1 M-350 BEGIN UNITS
- 3 12.5' RIGID GUARDRAIL UNITS
- 1 CAT-1
- 1 GUIDERAIL ANCHOR UNIT

MEDIAN GUARDRAIL INSTALLATION TYPICAL DETAILS (WITH EXISTING CABLE GUIDERAIL)

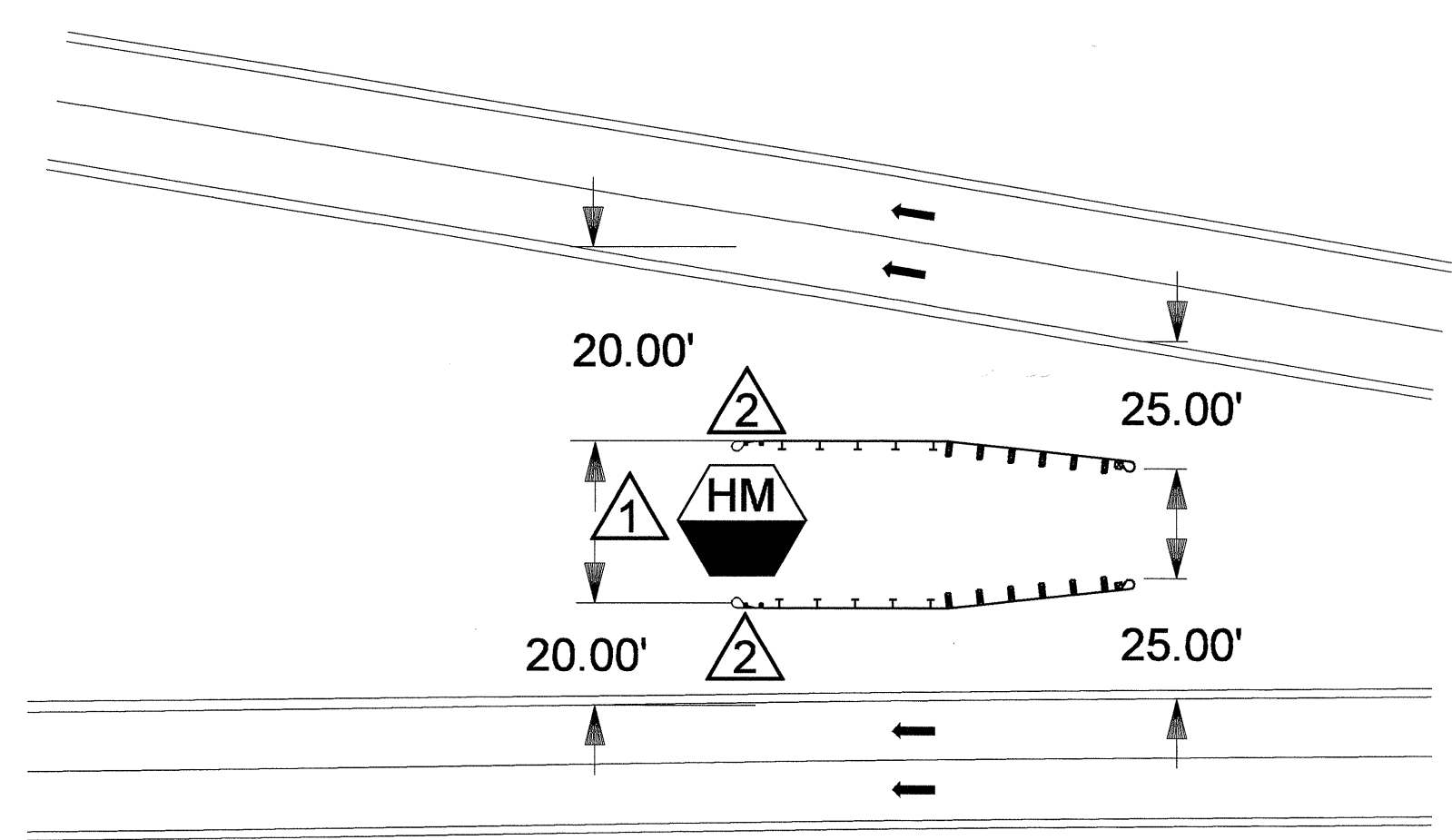

GORE AREA GR INVENTORY SUMMARY (PER SIDE)

- 1 M-350 BEGIN UNITS
- 3 12.5' RIGID GUARDRAIL UNITS
- 1 CAT-1

GORE AREA GUARDRAIL INSTALLATION TYPICAL DETAILS

- ① PLACE HIGH MAST FOUNDATION 5' FROM CENTER OF DITCHLINE
- ② TERMINATE GUARDRAIL PERPENDICULAR TO THE FAR EDGE OF HIGH MAST FOUNDATION.
- ③ BREAK EXISTING CABLE GUIDERAIL. INSTALL ANCHOR UNITS AND GUARDRAIL AS SHOWN. SEE STANDARD DRAWING 865.01 FOR GUIDERAIL AND ANCHOR UNIT INSTALLATION.

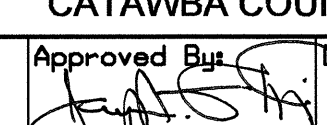
2				
1				
Rev.	Date	Description	Approved	
NORTH CAROLINA DEPARTMENT OF TRANSPORTATION ROADWAY DESIGN LIGHTING/ELECTRICAL SECTION				
GUARDRAIL INSTALLATION DETAILS				
CATAWBA COUNTY				
Drawn By:	RGH	Approved By:		

I:\DEC-2009\11-22\catawba county\catawba tracing\catawba.co.grdetails.psh.e13.dgn
 \$\$\$USERNAME\$\$\$

02/03/98