

09/08/99

See Sheet 1-A For Index of Sheets

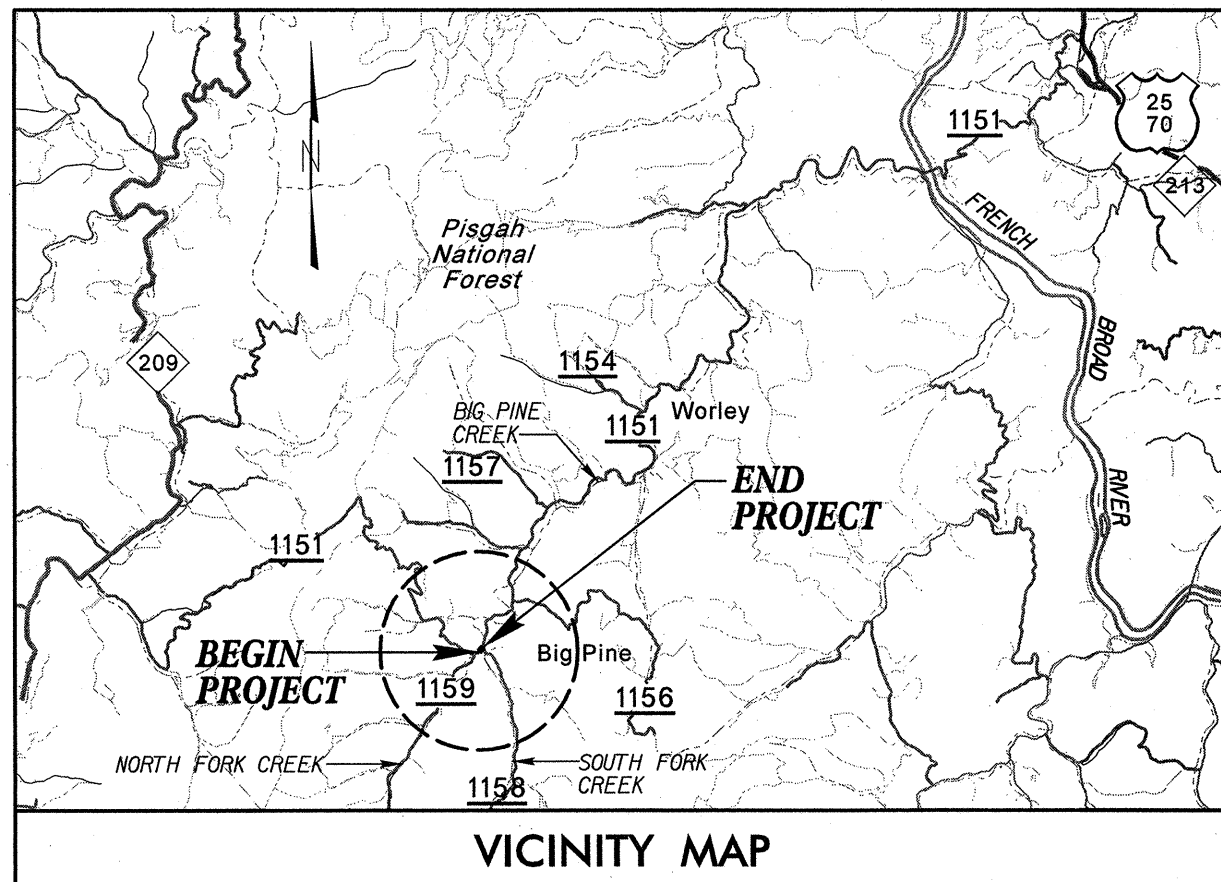

STATE OF NORTH CAROLINA  
DIVISION OF HIGHWAYS

**MADISON COUNTY**

**LOCATION: REPLACE BRIDGE No. 146 OVER  
BIG PINE CREEK ON SR 1151**

**TYPE OF WORK: GRADING, PAVING AND STRUCTURE**

STATE	STATE PROJECT REFERENCE NO.	SHEET NO.	TOTAL SHEETS
N.C.	B-3869	1	
STATE PROJ. NO.	F.A. PROJ. NO.	DESCRIPTION	
33314.1.1	BRSTP-1151(3)	PE	
33314.2.2	BRSTP-1151(3)	RW & UTIL	
33314.3.1	BRSTP-1151(3)	CONST	

**TIP PROJECT: B-3869**

**CONTRACT C202227**

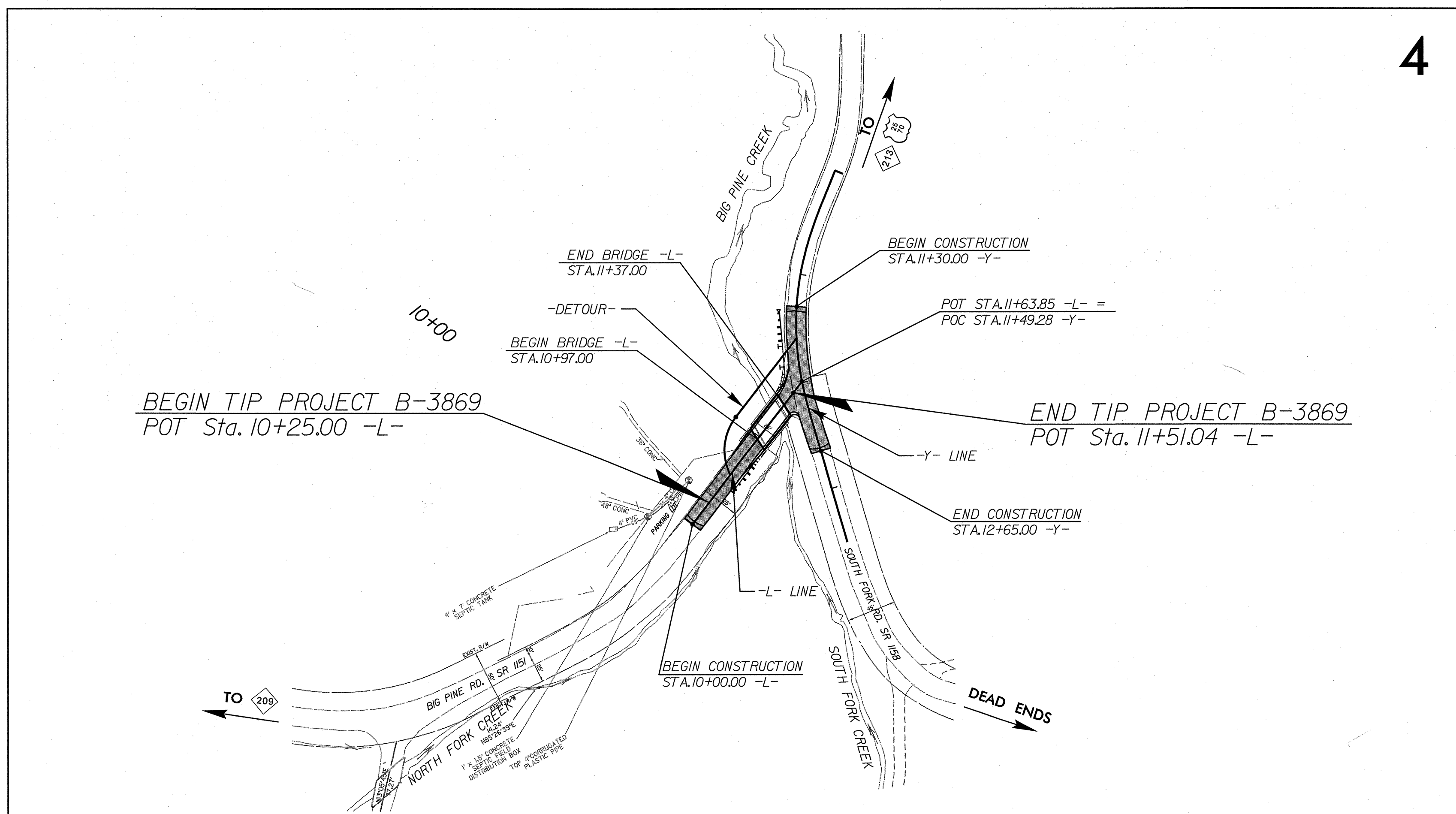

\*\* DESIGN EXCEPTION FOR DESIGN SPEED REQUIRED.

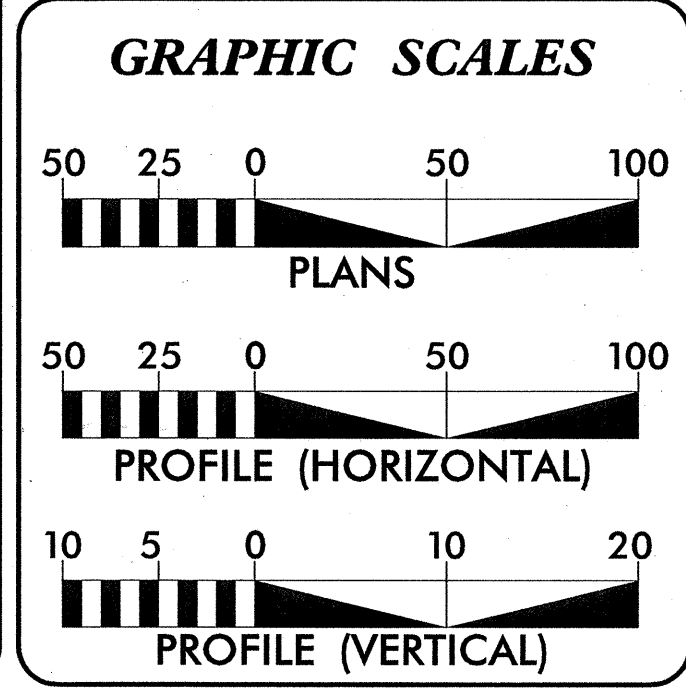

**DESIGN DATA**

ADT 2009 =	190
ADT 2029 =	250
DHV =	10 %
D =	60 %
T =	3 % *
V =	30 MPH**
* TTST 1 %	DUAL 2 %

CLASSIFICATION:  
RURAL MAJOR COLLECTOR

**PROJECT LENGTH**

LENGTH OF ROADWAY TIP PROJECT B-3869	=	0.016 MI.
LENGTH OF STRUCTURE TIP PROJECT B-3869	=	0.008 MI.
TOTAL LENGTH OF TIP PROJECT B-3869	=	0.024 MI.

Prepared In the Office of:

Stantec Consulting Inc.  
Suite 300, 801 Jones Franklin Road  
Raleigh, NC U.S.A. 27606  
Tel. 919.851.6866 Fax. 919.851.7024  
www.stantec.com

2006 STANDARD SPECIFICATIONS

**RIGHT OF WAY DATE:**  
AUGUST 18, 2006

**LETTING DATE:**  
JANUARY 19, 2010

**NCDOT CONTACT:** B. DOUG TAYLOR, PE  
PROJECT ENGINEER - ROADWAY DESIGN

ROBERT WILLIAMS, PE  
PROJECT ENGINEER

KEITH F. HUDSON  
PROJECT DESIGN ENGINEER

**HYDRAULICS ENGINEER**

ROBERT WILLIAMS  
P.E. 10/19/09

**ROADWAY DESIGN ENGINEER**

ROBERT A. WILLIAMS  
P.E. 10/19/09

**DIVISION OF HIGHWAYS  
STATE OF NORTH CAROLINA**

Aut. S.M. Millan  
P.E.  
STATE HIGHWAY DESIGN ENGINEER

10/16/2009  
U:\Roadway\Proj\B3869\_rdy\_tsh.dgn  
R. Williams

# STATE OF NORTH CAROLINA DIVISION OF HIGHWAYS

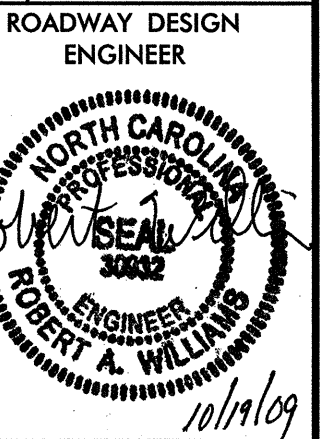

## INDEX OF SHEETS

SHEET NUMBER	SHEET
1	TITLE SHEET
1-A	INDEX OF SHEETS, GENERAL NOTES, AND LIST OF STANDARD DRAWINGS
1-B	CONVENTIONAL SYMBOLS
1-C	SURVEY CONTROL SHEET
2	PAVEMENT SCHEDULE, TYPICAL SECTIONS, AND WEDGING DETAILS
2-A	TYPE III - SHOP CURVED STRUCTURE ANCHOR UNIT
3	SUMMARY OF QUANTITIES
3-A	SUMMARY OF GUARDRAIL, EARTHWORK SUMMARY, AND ASPHALT PAVEMENT REMOVAL SUMMARY
4	PLAN/PROFILE SHEET
5	PLAN/PROFILE DETOUR SHEET
TCP-1 THRU TCP-6	TRAFFIC CONTROL PLANS
EC-1 THRU EC- 5	EROSION CONTROL PLANS
RF-1	REFORESTATION PLANS
SIGN-1 THRU SIGN-3	SIGNING PLANS
UO-1 THRU UO-2	UTILITY BY OTHER PLANS
X-A	CROSS SECTION SUMMARY SHEET
X-1 THRU X-11	CROSS-SECTIONS
S-1 THRU S-16	STRUCTURE PLANS

## GENERAL NOTES

**GENERAL NOTES:** 2006 SPECIFICATIONS  
EFFECTIVE: 07-18-06  
REVISED: 07-30-08

**GRADING AND SURFACING OR RESURFACING AND WIDENING:**  
THE GRADE LINES SHOWN DENOTE THE FINISHED ELEVATION OF THE PROPOSED SURFACING AT GRADE POINTS SHOWN ON THE TYPICAL SECTIONS. WHERE NO GRADE LINES ARE SHOWN, THE PROFILES SHOWN DENOTE THE TOP ELEVATION OF THE EXISTING PAVEMENT ALONG THE CENTER LINE OF SURVEY ON WHICH THE PROPOSED RESURFACING WILL BE PLACED. GRADE LINES MAY BE ADJUSTED BY THE ENGINEER IN ORDER TO SECURE A PROPER TIE-IN.

**CLEARING:**  
CLEARING ON THIS PROJECT SHALL BE PERFORMED TO THE LIMITS ESTABLISHED BY METHOD II.

**SUPERELEVATION:**  
ALL CURVES ON THIS PROJECT SHALL BE SUPERELEVATED IN ACCORDANCE WITH STD. NO. 225.04 USING THE RATE OF SUPERELEVATION AND RUNOFF SHOWN ON THE PLANS. SUPERELEVATION IS TO BE REVOLVED ABOUT THE GRADE POINTS SHOWN ON THE TYPICAL SECTIONS.

**SHOULDER CONSTRUCTION:**  
ASPHALT, EARTH, AND CONCRETE SHOULDER CONSTRUCTION ON THE HIGH SIDE OF SUPERELEVATED CURVES SHALL BE IN ACCORDANCE WITH STD. NO. 560.01.

**UNDERDRAINS:**  
UNDERDRAINS SHALL BE CONSTRUCTED IN ACCORDANCE WITH STD. NO. 815.03 AT LOCATIONS DIRECTED BY THE ENGINEER.

**GUARDRAIL:**  
THE GUARDRAIL LOCATIONS SHOWN ON THE PLANS MAY BE ADJUSTED DURING CONSTRUCTION AS DIRECTED BY THE ENGINEER. THE CONTRACTOR SHOULD CONSULT WITH THE ENGINEER PRIOR TO ORDERING GUARDRAIL MATERIAL.

**TEMPORARY SHORING:**  
SHORING REQUIRED FOR THE MAINTENANCE OF TRAFFIC WILL BE PAID FOR AS "EXTRA WORK" IN ACCORDANCE WITH SECTION 104-7.

**SUBSURFACE PLANS:**  
NO SUBSURFACE PLANS ARE AVAILABLE ON THIS PROJECT. THE CONTRACTOR SHOULD MAKE HIS OWN INVESTIGATION AS TO THE SUBSURFACE CONDITIONS.

**END BENTS:**  
THE ENGINEER SHALL CHECK THE STRUCTURE END BENT PLANS, DETAILS, AND CROSS-SECTION PRIOR TO SETTING OF THE SLOPE STAKES FOR THE EMBANKMENT OR EXCAVATION APPROACHING A BRIDGE.

**UTILITIES:**  
THE UTILITY OWNERS ON THIS PROJECT ARE: FRENCH BROAD ELECTRIC  
ANY RELOCATION OF EXISTING UTILITIES WILL BE ACCOMPLISHED BY OTHERS.

**RIGHT-OF-WAY MARKERS:**  
ALL RIGHT-OF-WAY MARKERS ON THIS PROJECT SHALL BE PLACED BY CONTRACT.

## ROADWAY STANDARD DRAWINGS

2006 ROADWAY ENGLISH STANDARD DRAWINGS

EFF. 07-18-06  
REV. 01-02-07

The following Roadway Standards as appear in "Roadway Standard Drawings" Highway Design Branch - N. C. Department of Transportation - Raleigh, N. C., Dated July 18, 2006 are applicable to this project and by reference hereby are considered a part of these plans:

STD. NO.	TITLE
<b>DIVISION 2 - EARTHWORK</b>	
200.02	Method of Clearing - Method II
225.02	Guide for Grading Subgrade - Secondary and Local
225.04	Method of Obtaining Superlevation - Two Lane Pavement
225.06	Method of Grading Sight Distance at Intersections
<b>DIVISION 5 - SUBGRADE, BASES AND SHOULDERS</b>	
560.01	Method of Shoulder Construction - High Side of Superelevated Curve - Method I
<b>DIVISION 8 - INCIDENTALS</b>	
806.01	Concrete Right-of-Way Marker
806.02	Granite Right-of-Way Marker
815.03	Pipe Underdrain and Blind Drain
862.01	Guardrail Placement
862.02	Guardrail Installation
862.03	Structure Anchor Units













Note: Not to Scale

\*S.U.E. = Subsurface Utility Engineering











STATE OF NORTH CAROLINA  
DIVISION OF HIGHWAYS

# CONVENTIONAL PLAN SHEET SYMBOLS











### BOUNDARIES AND PROPERTY:

State Line	_____
County Line	_____
Township Line	_____
City Line	_____
Reservation Line	_____
Property Line	_____
Existing Iron Pin	_____ 
Property Corner	_____ 
Property Monument	_____ 
Parcel/Sequence Number	_____ 
Existing Fence Line	_____ 
Proposed Woven Wire Fence	_____ 
Proposed Chain Link Fence	_____ 
Proposed Barbed Wire Fence	_____ 
Existing Wetland Boundary	_____ 
Proposed Wetland Boundary	_____ 
Existing Endangered Animal Boundary	_____ 
Existing Endangered Plant Boundary	_____ 





### BUILDINGS AND OTHER CULTURE:

Gas Pump Vent or U/G Tank Cap	_____ 
Sign	_____ 
Well	_____ 
Small Mine	_____ 
Foundation	_____ 
Area Outline	_____ 
Cemetery	_____ 
Building	_____ 
School	_____ 
Church	_____ 
Dam	_____ 



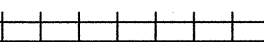

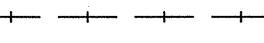









### HYDROLOGY:

Stream or Body of Water	_____
Hydro, Pool or Reservoir	_____ 
Jurisdictional Stream	_____ 
Buffer Zone 1	_____ 
Buffer Zone 2	_____ 
Flow Arrow	_____ 
Disappearing Stream	_____ 
Spring	_____ 
Wetland	_____ 
Proposed Lateral, Tail, Head Ditch	_____ 
False Sump	_____ 











### RAILROADS:

Standard Gauge	_____ 
RR Signal Milepost	_____ 
Switch	_____ 
RR Abandoned	_____ 
RR Dismantled	_____ 







### RIGHT OF WAY:

Baseline Control Point	_____ 
Existing Right of Way Marker	_____ 
Existing Right of Way Line	_____ 
Proposed Right of Way Line	_____ 
Proposed Right of Way Line with Iron Pin and Cap Marker	_____ 
Proposed Right of Way Line with Concrete or Granite Marker	_____ 
Existing Control of Access	_____ 
Proposed Control of Access	_____ 
Existing Easement Line	_____ 
Proposed Temporary Construction Easement	_____ 
Proposed Temporary Drainage Easement	_____ 
Proposed Permanent Drainage Easement	_____ 
Proposed Permanent Utility Easement	_____ 
Proposed Temporary Utility Easement	_____ 
Proposed Permanent Easement with Iron Pin and Cap Marker	_____ 





### ROADS AND RELATED FEATURES:

Existing Edge of Pavement	_____ 
Existing Curb	_____ 
Proposed Slope Stakes Cut	_____ 
Proposed Slope Stakes Fill	_____ 
Proposed Wheel Chair Ramp	_____ 
Existing Metal Guardrail	_____ 
Proposed Guardrail	_____ 
Existing Cable Guiderail	_____ 
Proposed Cable Guiderail	_____ 
Equality Symbol	_____ 
Pavement Removal	_____ 



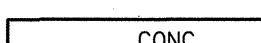
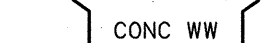



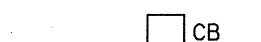
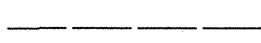
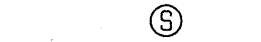
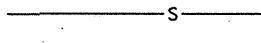



### VEGETATION:

Single Tree	_____ 
Single Shrub	_____ 
Hedge	_____ 
Woods Line	_____ 
Orchard	_____ 
Vineyard	_____ 













### EXISTING STRUCTURES:

MAJOR:	
Bridge, Tunnel or Box Culvert	_____ 
Bridge Wing Wall, Head Wall and End Wall	_____ 
MINOR:	
Head and End Wall	_____ 
Pipe Culvert	_____ 
Footbridge	_____ 
Drainage Box: Catch Basin, DI or JB	_____ 
Paved Ditch Gutter	_____ 
Storm Sewer Manhole	_____ 
Storm Sewer	_____ 







### UTILITIES:

POWER:	
Existing Power Pole	_____ 
Proposed Power Pole	_____ 
Existing Joint Use Pole	_____ 
Proposed Joint Use Pole	_____ 
Power Manhole	_____ 
Power Line Tower	_____ 
Power Transformer	_____ 
U/G Power Cable Hand Hole	_____ 
H-Frame Pole	_____ 
Recorded U/G Power Line	_____ 
Designated U/G Power Line (S.U.E.*)	_____ 









### TELEPHONE:

Existing Telephone Pole	_____ 
Proposed Telephone Pole	_____ 
Telephone Manhole	_____ 
Telephone Booth	_____ 
Telephone Pedestal	_____ 
Telephone Cell Tower	_____ 
U/G Telephone Cable Hand Hole	_____ 
Recorded U/G Telephone Cable	_____ 
Designated U/G Telephone Cable (S.U.E.*)	_____ 
Recorded U/G Telephone Conduit	_____ 
Designated U/G Telephone Conduit (S.U.E.*)	_____ 
Recorded U/G Fiber Optics Cable	_____ 
Designated U/G Fiber Optics Cable (S.U.E.*)	_____ 





### WATER:

Water Manhole	_____ 
Water Meter	_____ 
Water Valve	_____ 
Water Hydrant	_____ 
Recorded U/G Water Line	_____ 
Designated U/G Water Line (S.U.E.*)	_____ 
Above Ground Water Line	_____ 







### TV:

TV Satellite Dish	_____ 
TV Pedestal	_____ 
TV Tower	_____ 
U/G TV Cable Hand Hole	_____ 
Recorded U/G TV Cable	_____ 
Designated U/G TV Cable (S.U.E.*)	_____ 
Recorded U/G Fiber Optic Cable	_____ 
Designated U/G Fiber Optic Cable (S.U.E.*)	_____ 











### GAS:

Gas Valve	_____ 
Gas Meter	_____ 
Recorded U/G Gas Line	_____ 
Designated U/G Gas Line (S.U.E.*)	_____ 
Above Ground Gas Line	_____ 

### SANITARY SEWER:

Sanitary Sewer Manhole	_____ 
Sanitary Sewer Cleanout	_____ 
U/G Sanitary Sewer Line	_____ 
Above Ground Sanitary Sewer	_____ 
Recorded SS Forced Main Line	_____ 
Designated SS Forced Main Line (S.U.E.*)	_____ 

### MISCELLANEOUS:

Utility Pole	_____ 
Utility Pole with Base	_____ 
Utility Located Object	_____ 
Utility Traffic Signal Box	_____ 
Utility Unknown U/G Line	_____ 
U/G Tank; Water, Gas, Oil	_____ 
A/G Tank; Water, Gas, Oil	_____ 
U/G Test Hole (S.U.E.*)	_____ 
Abandoned According to Utility Records	_____ 
End of Information	_____ 



# SURVEY CONTROL SHEET B-3869

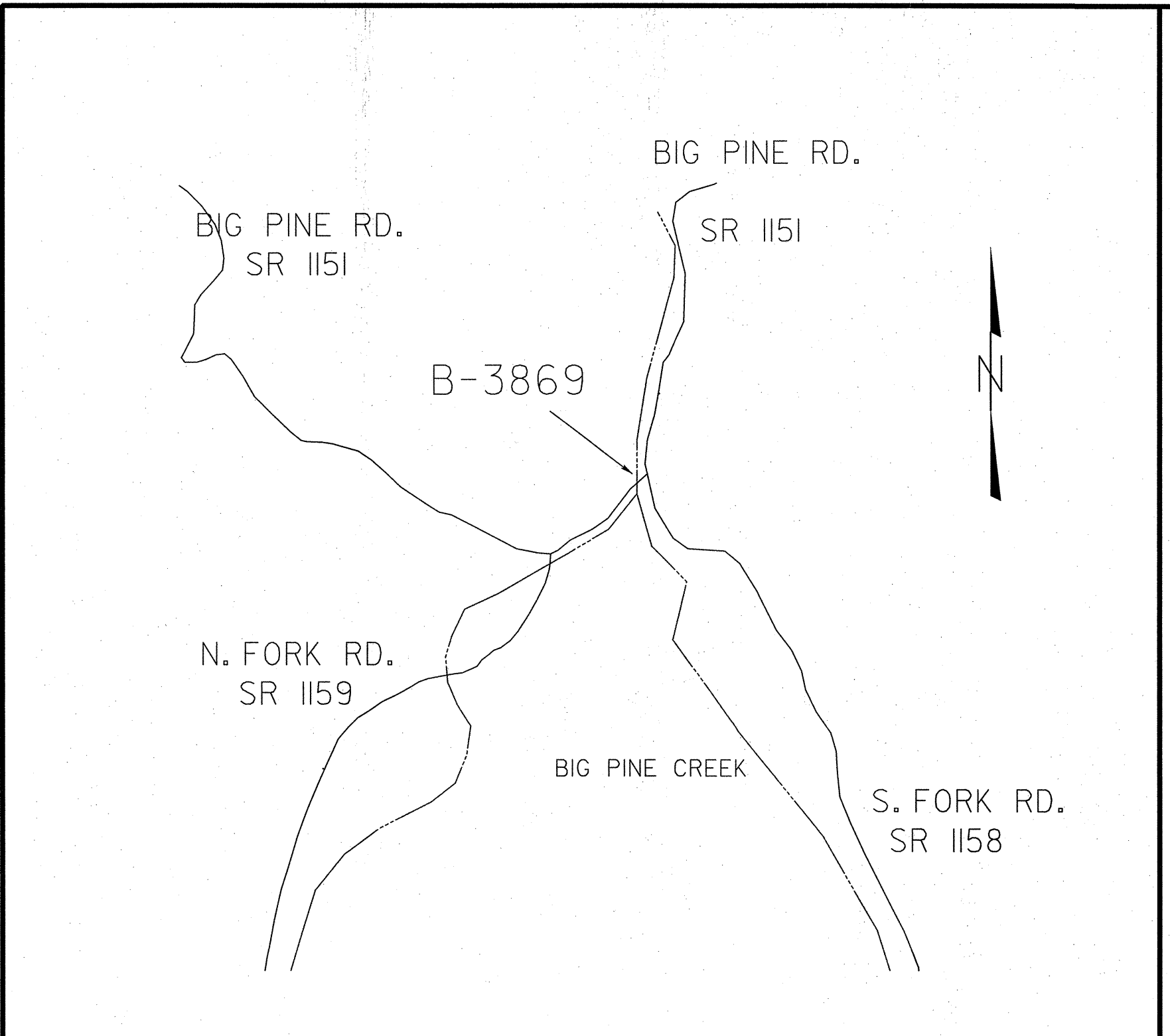

BL POINT	DESC.	NORTH	EAST	ELEVATION	L STATION	OFFSET
GPS1	B3869-1	762438.7704	869349.6655	2490.19	OUTSIDE PROJECT LIMITS	
3	BL-3	762677.4997	869674.4080	2479.26	11+72.92	19.96 RT
4	BL-4	763059.1633	869773.5191	2477.72	OUTSIDE PROJECT LIMITS	

BY POINT	DESC.	NORTH	EAST	ELEVATION	Y STATION	OFFSET
Y3	BL-3	762677.4997	869674.4080	2479.26	12+79.89	89.51 RT
5	BY-4	762489.6986	869853.0889	2481.63	OUTSIDE PROJECT LIMITS	

\*\*\*\*\*  
 BM1 ELEVATION = 2496.92  
 N 762348 E 869303  
 L STATION 10+00  
 S 48° 56' 25.6" W DIST 320.66  
 NAIL IN BASE OF 18 INCH TWIN POPLAR  
 \*\*\*\*\*

\*\*\*\*\*  
 BM2 ELEVATION = 2474.58  
 N 762860 E 869640  
 L STATION 13+18 97 LEFT  
 NAIL IN BASE OF 38 INCH WHITE OAK  
 \*\*\*\*\*

\*\*\*\*\*  
 BM3 ELEVATION = 2471.15  
 N 763102 E 869759  
 Y STATION 10+00  
 N 4° 28' 02.6" W DIST 129.19  
 NAIL IN BASE OF 18 INCH POPLAR  
 \*\*\*\*\*

**DATUM DESCRIPTION**

THE LOCALIZED COORDINATE SYSTEM DEVELOPED FOR THIS PROJECT IS BASED ON THE STATE PLANE COORDINATES ESTABLISHED BY NCDOT FOR MONUMENT "B3869-1"  
 WITH NAD 1983/95 STATE PLANE GRID COORDINATES OF  
 NORTHING: 762438.7704(±) EASTING: 869349.6655(±)  
 THE AVERAGE COMBINED GRID FACTOR USED ON THIS PROJECT (GROUND TO GRID) IS: 0.99981377  
 THE N.C. LAMBERT GRID BEARING AND LOCALIZED HORIZONTAL GROUND DISTANCE FROM "B3869-1" TO -L- STATION 10+00.00 IS  
 N 58°21'33.7" E 228.73'  
 ALL LINEAR DIMENSIONS ARE LOCALIZED HORIZONTAL DISTANCES  
 VERTICAL DATUM USED IS NAVD 88

**NCDOT GPS STA. "B3869-1"  
LOCALIZED PROJECT COORDINATES**

**N - 762438.7704  
E - 869349.6655**

**NOTES:**

1. THE CONTROL DATA FOR THIS PROJECT CAN BE FOUND ELECTRONICALLY BY SELECTING PROJECT CONTROL DATA AT:  
[HTTP://WWW.DO.H.DOT.STATE.NC.US/PRECONSTRUCT/HIGHWAY/LOCATION/PROJECT/](http://www.doh.dot.state.nc.us/preconstruct/highway/location/project/)

THE FILES TO BE FOUND ARE AS FOLLOWS:  
 B3869\_LS\_CONTROL\_051004.TXT

SITE CALIBRATION INFORMATION HAS NOT BEEN PROVIDED FOR THIS PROJECT. IF FURTHER INFORMATION IS NEEDED, PLEASE CONTACT THE LOCATION AND SURVEYS UNIT.

● INDICATES GEODETIC CONTROL MONUMENTS USED OR SET FOR HORIZONTAL PROJECT CONTROL BY THE NCDOT LOCATION AND SURVEYS UNIT.  
 PROJECT CONTROL ESTABLISHED USING GLOBAL POSITIONING SYSTEM.  
 NETWORK ESTABLISHED FROM EXISTING HARN MONUMENTATION

**-L- STA. 13+35.25 END STATE PROJECT 33314.1.1  
LOCALIZED PROJECT COORDINATES**

**N - 762829.9187  
E - 869733.7177**

**-L- STA. 10+00.00 BEGIN STATE PROJECT 33314.1.1  
LOCALIZED PROJECT COORDINATES**

**N - 762558.7577  
E - 869544.3925**

**-Y- STA. 10+00.00 STATE PROJECT 33314.1.1  
LOCALIZED PROJECT COORDINATES**

**N - 762973.5703  
E - 869769.3800**

**-Y- STA. 13+50.96 STATE PROJECT 33314.1.1  
LOCALIZED PROJECT COORDINATES**

**N - 762634.3310  
E - 869780.2382**

**NCDOT GPS STA. "B3869-2"  
LOCALIZED PROJECT COORDINATES**

**N - 761975.1526  
E - 870303.0232**

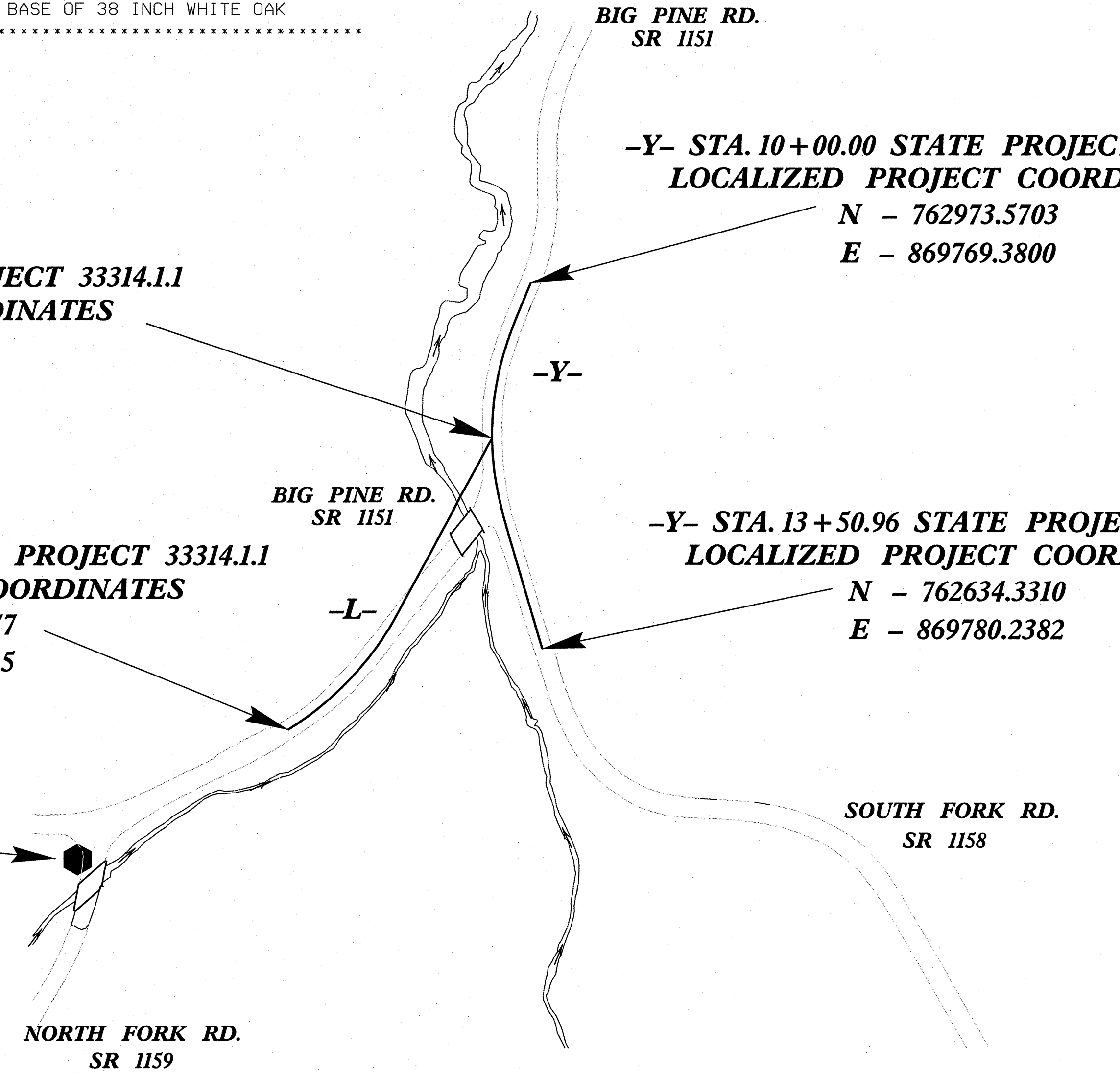

NOTE: DRAWING NOT TO SCALE

I:\16\2009\LocationSurveys\B3869\_1s\_1c\_051004.dgn

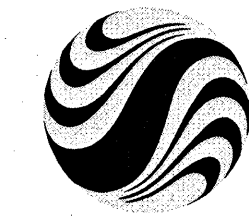

Stantec Consulting Inc.  
 Suite 300, 801 Jones Franklin Road  
 Raleigh NC U.S.A.  
 27606  
 Tel: 919.851.6866  
 Fax: 919.851.7024  
 www.stantec.com

PROJECT REFERENCE NO. B-3869	SHEET NO. 2
ROADWAY DESIGN ENGINEER 	PAVEMENT DESIGN ENGINEER 

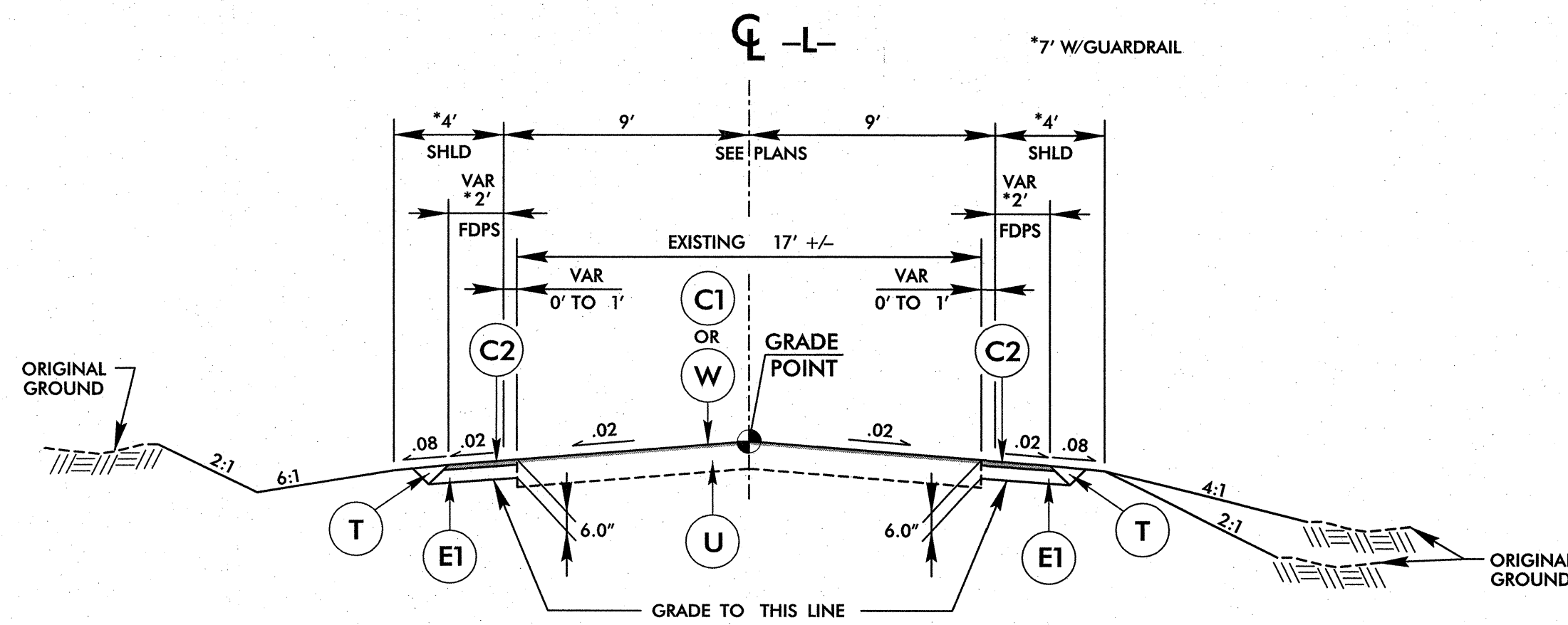

**TYPICAL SECTION NO. 1**

-L- STA. 10+25.00 TO STA. 10+97.00 (BEGIN BRIDGE)  
 -L- STA. 11+37.00 (END BRIDGE) TO STA. 11+51.04

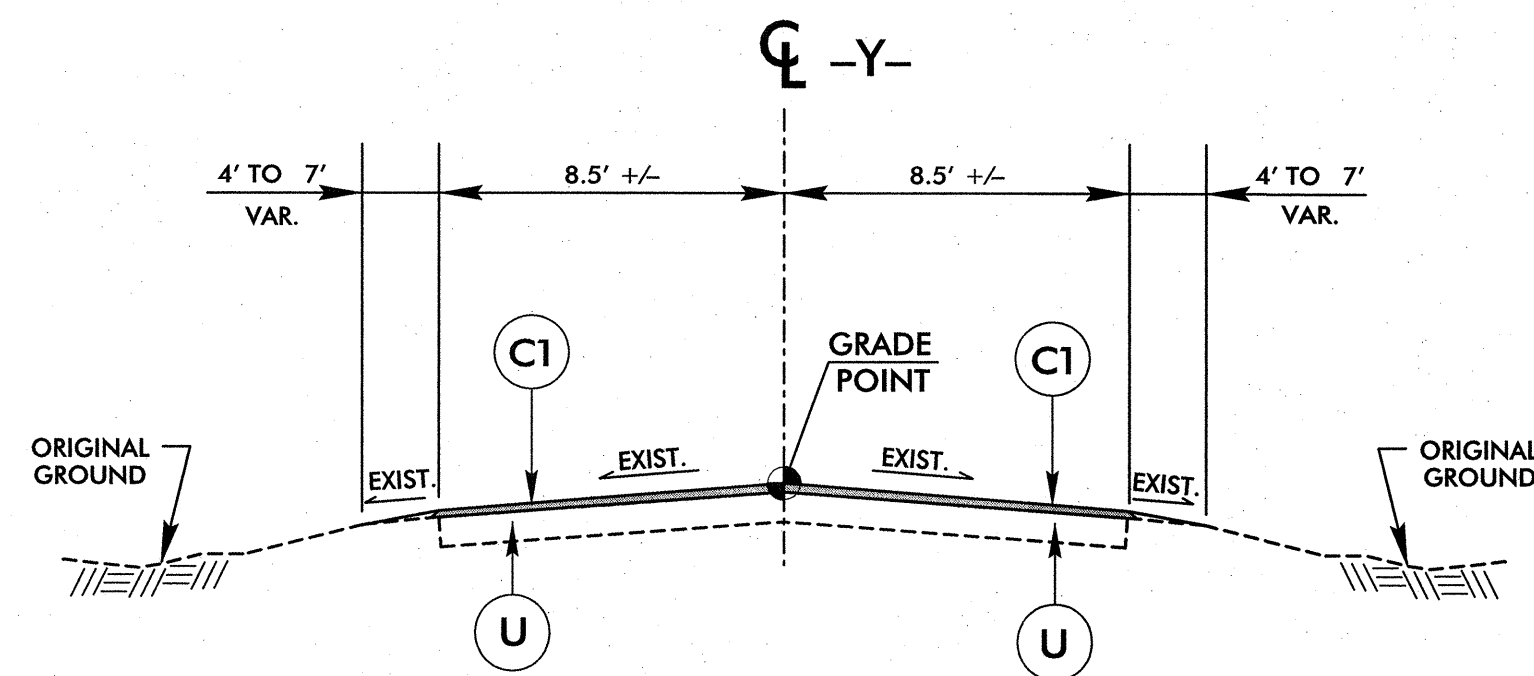

**TYPICAL SECTION NO. 2**

-Y- STA. 11+30.00 TO STA. 12+65.00

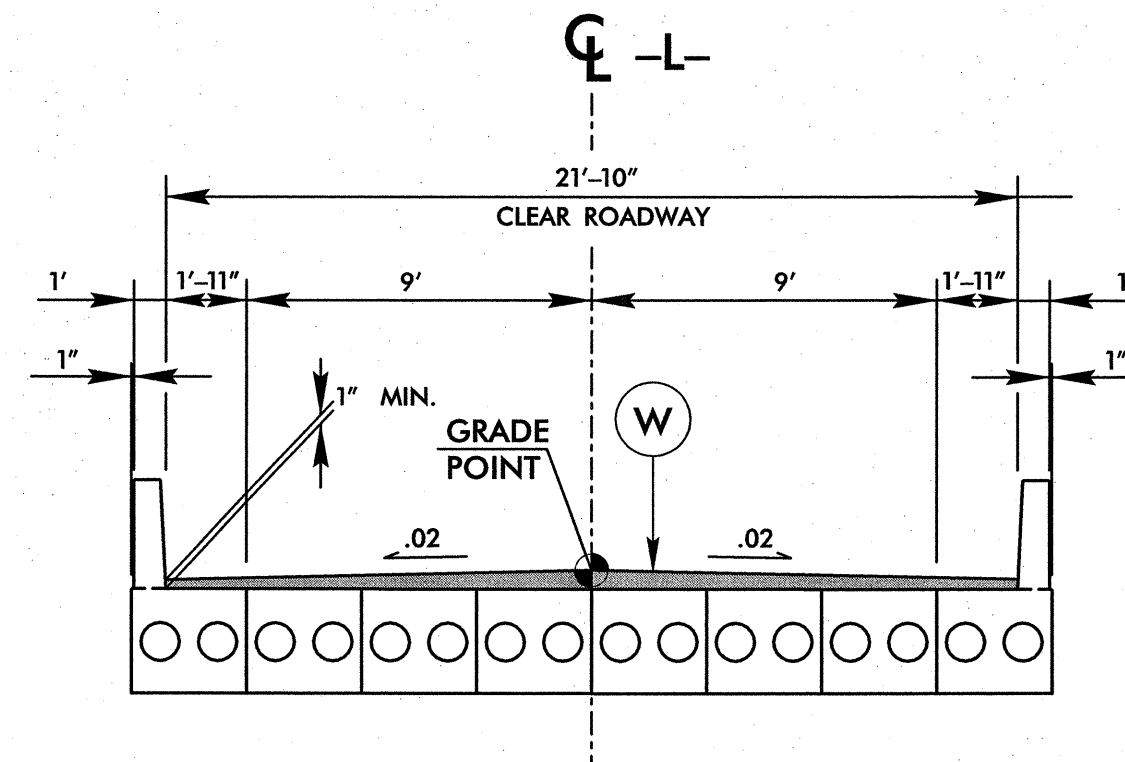

**CORED SLAB BRIDGE**

8 PRESTRESSED CONC. CORED SLAB UNITS = 24'-0"

**TYPICAL SECTION NO. 3**

-L- STA. 10+97.00 TO STA. 11+37.00

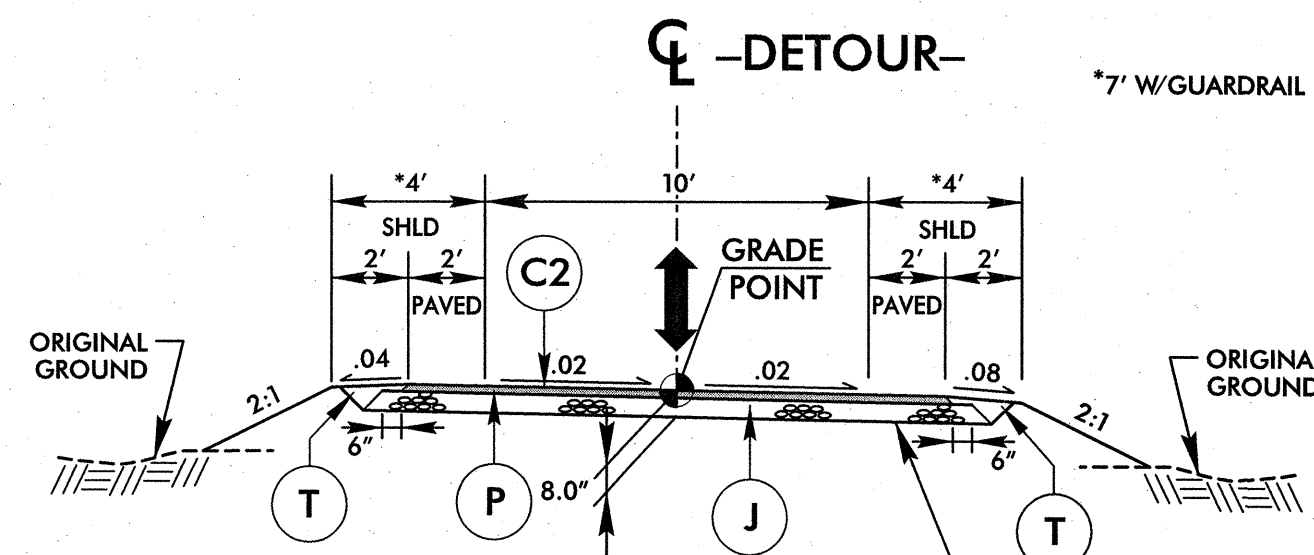

**TYPICAL SECTION NO. 4**

ONE LANE ONE WAY  
 -DETOUR- STA. 10+10.18 TO STA. 10+58.40 (BEGIN TEMP BRIDGE)  
 -DETOUR- STA. 11+13.40 (END TEMP BRIDGE) TO STA. 11+32.89

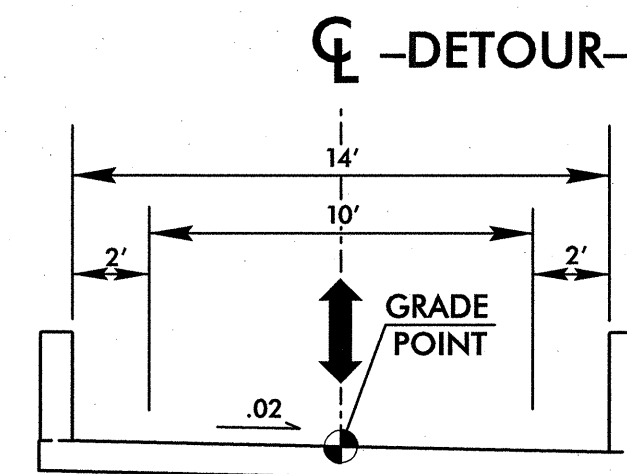

**TYPICAL SECTION NO. 5**

ONE LANE ONE WAY STRUCTURE  
 -DETOUR- STA. 10+58.40 TO STA. 11+13.40

PAVEMENT SCHEDULE	
C1	PROP. APPROX. 1.0" ASPHALT CONCRETE SURFACE COURSE, TYPE SF9.5A, AT AN AVERAGE RATE OF 110 LBS. PER SQ. YD.
C2	PROP. APPROX. 2.0" ASPHALT CONCRETE SURFACE COURSE, TYPE SF9.5A, AT AN AVERAGE RATE OF 110 LBS. PER SQ. YD. IN EACH OF TWO LAYERS
C3	PROP. VAR. DEPTH ASPHALT CONCRETE SURFACE COURSE, TYPE SF9.5A, AT AN AVERAGE RATE OF 110 LBS. PER SQ. YD. PER 1" DEPTH. TO BE PLACED IN LAYERS NOT LESS THAN 1" OR GREATER THAN 1.5"
E1	PROP. APPROX. 4.0" ASPHALT CONCRETE BASE COURSE, TYPE B25.0B, AT AN AVERAGE RATE OF 456 LBS. PER SQ. YD.
E2	PROP. VAR. DEPTH ASPHALT CONCRETE BASE COURSE, TYPE B25.0B, AT AN AVERAGE RATE OF 114 LBS. PER SQ. YD. PER 1" DEPTH. TO BE PLACED IN LAYERS NOT LESS THAN 3" OR GREATER THAN 5.5"
J	6" AGGREGATE BASE COURSE
P	PRIME COAT AT THE RATE OF .35 GAL PER SQ. YARD
T	EARTH MATERIAL
U	EXISTING PAVEMENT
W	WEDGING

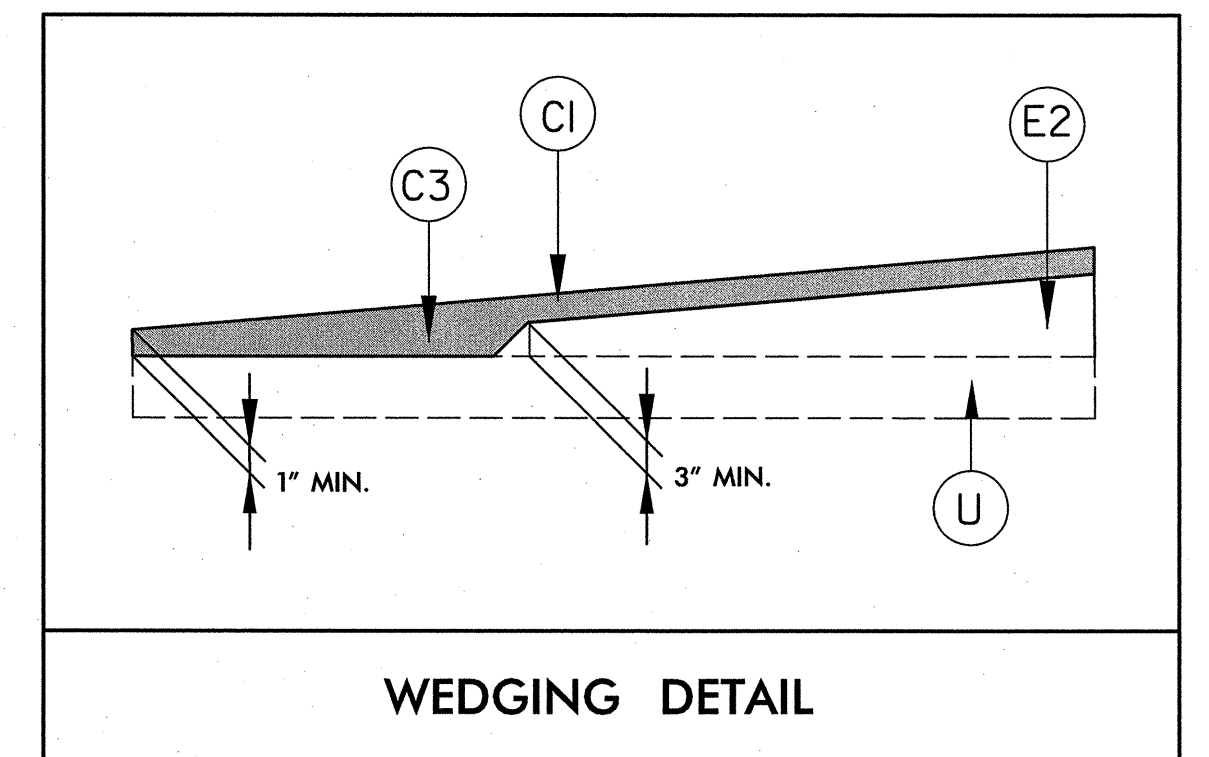

**WEDGING DETAIL**

NOTE:  
 ALL PAVEMENT STRUCTURE SLOPES ARE 1:1 UNLESS OTHERWISE SPECIFIED.





STATE OF NORTH CAROLINA  
DIVISION OF HIGHWAYS  
**SUMMARY OF QUANTITIES**

STATE OF NORTH CAROLINA  
DIVISION OF HIGHWAYS  
ROADWAY SUMMARY OF QUANTITIES FOR CONTRACT - C202227

ItemNumber	Sec #	Quantity	Unit	Description	ItemNumber	Sec #	Quantity	Unit	Description	ItemNumber	Sec #	Quantity	Unit	Description
000100000-N	800	Lump Sum		MOBILIZATION	318000000-N	862	1	EA	GUARDRAIL ANCHOR UNITS, TYPE ***** (III SHOP CURVED)	600900000-E	1610	15	TON	STONE FOR EROSION CONTROL, CLASS B
000400000-N	801	Lump Sum		CONSTRUCTION SURVEYING	321500000-N	862	1	EA	GUARDRAIL ANCHOR UNITS, TYPE III	601200000-E	1610	65	TON	SEDIMENT CONTROL STONE
003600000-E	225	100	CY	UNDERCUT EXCAVATION	338200000-E	862	12.5	LF	TEMPORARY STEEL BM GUARDRAIL (SHOP CURVED)	601500000-E	1615	0.5	ACR	TEMPORARY MULCHING
004300000-N	226	Lump Sum		GRADING	338700000-N	862	1	EA	GUARDRAIL ANCHOR UNITS, TYPE ***** TEMPORARY (III SHOP CURVED)	601800000-E	1620	50	LB	SEED FOR TEMPORARY SEEDING
005000000-E	226	1	ACR	SUPPLEMENTARY CLEARING & GRUB-BING	338700000-N	862	1	EA	GUARDRAIL ANCHOR UNITS, TYPE ***** TEMPORARY (III SHOP CURVED)	602100000-E	1620	0.25	TON	FERTILIZER FOR TEMPORARY SEEDING
008000000-E	SP	100	TON	CLASS IV SUBGRADE STABILIZATION	338700000-N	862	2	EA	GUARDRAIL ANCHOR UNITS, TYPE ***** TEMPORARY (III)	602400000-E	1622	200	LF	TEMPORARY SLOPE DRAINS
019500000-E	265	100	CY	SELECT GRANULAR MATERIAL	338700000-N	862	2	EA	GUARDRAIL ANCHOR UNITS, TYPE ***** TEMPORARY (III)	602700000-N	1622	4	EA	INLET PROTECTION AT TEMPORARY SLOPE DRAINS
019600000-E	270	100	SY	FABRIC FOR SOIL STABILIZATION	338900000-N	SP	3	EA	GUARDRAIL ANCHOR UNITS, TYPE ***** TEMPORARY (350 TL-2)	602900000-E	SP	550	LF	SAFETY FENCE
112100000-E	520	42	TON	AGGREGATE BASE COURSE	343500000-N	SP	1	EA	GENERIC GUARDRAIL ITEM IMPACT ATTENUATOR UNIT, TYPE 350 TL-2	603000000-E	1630	40	CY	SILT EXCAVATION
122000000-E	545	25	TON	INCIDENTAL STONE BASE	365600000-E	876	600	SY	FILTER FABRIC FOR DRAINAGE	603600000-E	1631	7,500	SY	MATting FOR EROSION CONTROL
127500000-E	600	42	GAL	PRIME COAT	407200000-E	903	39	LF	SUPPORTS, 3-LB STEEL U-CHANNEL	604200000-E	1632	280	LF	1/4" HARDWARE CLOTH
148900000-E	610	12	TON	ASPHALT CONC BASE COURSE, TYPE B25.0B	410200000-N	904	3	EA	SIGN ERECTION, TYPE E	607103000-E	SP	20	LF	COIR FIBER BAFFLES
152500000-E	610	70	TON	ASPHALT CONC SURFACE COURSE, TYPE SF9.5A	415500000-N	907	9	EA	DISPOSAL OF SIGN SYSTEM, U-CHANNEL	608400000-E	1660	0.5	ACR	SEEDING & MULCHING
156000000-E	620	6	TON	ASPHALT BINDER FOR PLANT MIX, GRADE PG 64-22	440000000-E	1110	213	SF	WORK ZONE SIGNS (STATIONARY)	608700000-E	1660	0.5	ACR	MOWING
200000000-N	806	6	EA	RIGHT OF WAY MARKERS	440500000-E	1110	144	SF	WORK ZONE SIGNS (PORTABLE)	609000000-E	1661	50	LB	SEED FOR REPAIR SEEDING
202200000-E	815	15	CY	SUBDRAIN EXCAVATION	441000000-E	1110	32	SF	WORK ZONE SIGNS (BARRICADE MOUNTED)	609300000-E	1661	0.25	TON	FERTILIZER FOR REPAIR SEEDING
203300000-E	815	10	CY	SUBDRAIN FINE AGGREGATE	443000000-N	1130	30	EA	DRUMS	609600000-E	1662	50	LB	SEED FOR SUPPLEMENTAL SEEDING
204400000-E	815	50	LF	6" PERFORATED SUBDRAIN PIPE	444500000-E	1145	48	LF	BARRICADES (TYPE III)	610800000-E	1665	0.25	TON	FERTILIZER TOPDRESSING
205500000-E	815	3	EA	6" SUBDRAIN PIPE WYES, TEES, & ELBOWS	445000000-N	1150	480	HR	FLAGGER	611450000-N	SP	12	MHR	SPECIALIZED HAND MOWING
206600000-N	815	1	EA	CONCRETE PAD FOR SUBDRAIN PIPE OUTLET	465000000-N	1251	25	EA	TEMPORARY RAISED PAVEMENT MARKERS	611700000-N	SP	12	EA	RESPONSE FOR EROSION CONTROL
207700000-E	815	6	LF	6" OUTLET PIPE (SUBDRAINS)	481000000-E	1205	5,642	LF	PAINT PAVEMENT MARKING LINES (4")	612300000-E	1670	0.1	ACR	REFORESTATION
303000000-E	862	25	LF	STEEL BM GUARDRAIL	485000000-E	1205	350	LF	REMOVAL OF PAVEMENT MARKING LINES (4")					
304500000-E	862	12.5	LF	STEEL BM GUARDRAIL, SHOP CURVED	600000000-E	1605	700	LF	TEMPORARY SILT FENCE					
315000000-N	862	5	EA	ADDITIONAL GUARDRAIL POSTS	600600000-E	1610	310	TON	STONE FOR EROSION CONTROL, CLASS A					
316500000-N	SP	2	EA	GUARDRAIL ANCHOR UNITS, TYPE ***** (350 TL-2)										





8/17/99

REVISIONS

PROJECT REFERENCE NO. B-3869	SHEET NO. 4
ROADWAY DESIGN ENGINEER 	HYDRAULICS ENGINEER 

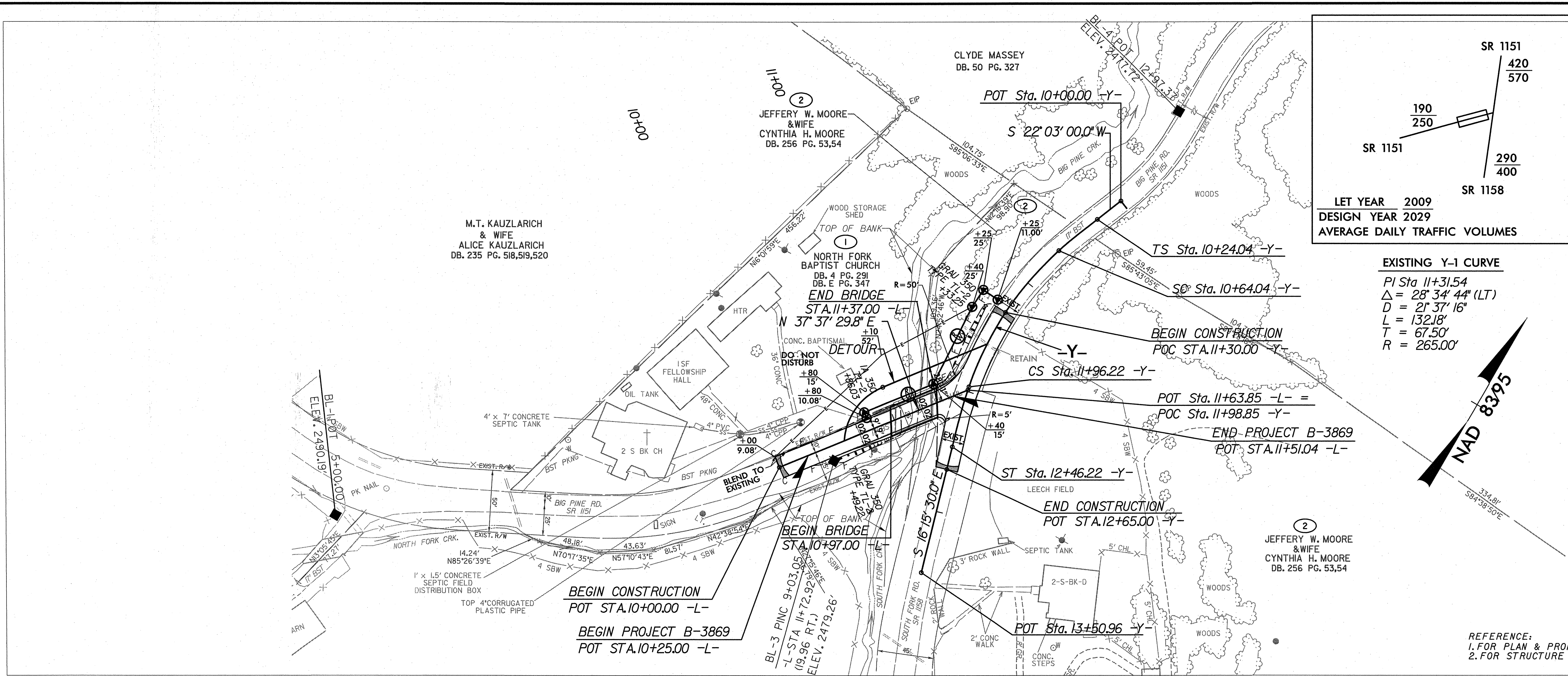

EXISTING Y-1 CURVE  
 PI Sta 11+31.54  
 $\Delta = 28^\circ 34' 44''$  (LT)  
 $D = 21^\circ 37' 16''$   
 $L = 132.18'$   
 $T = 67.50'$   
 $R = 265.00'$

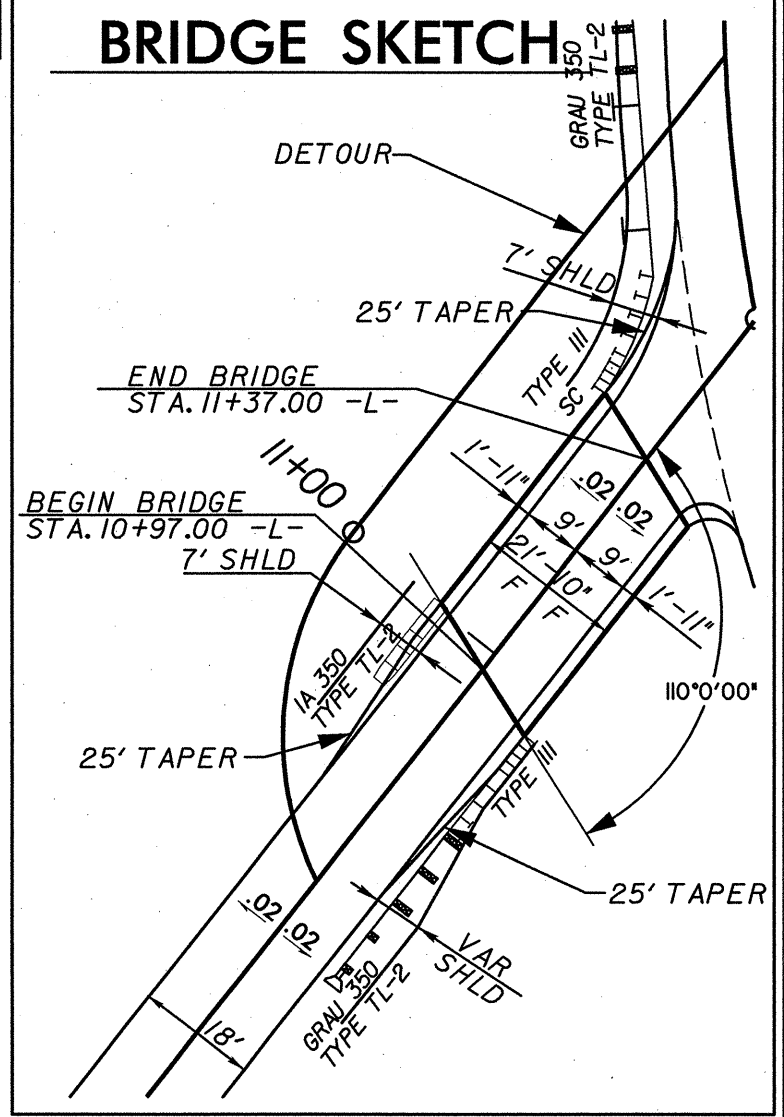

REFERENCE:  
 1. FOR PLAN & PROFILE OF DETOUR, SEE SHEET NO. 5  
 2. FOR STRUCTURE PLANS, SEE SHEETS S-1 THRU S-16

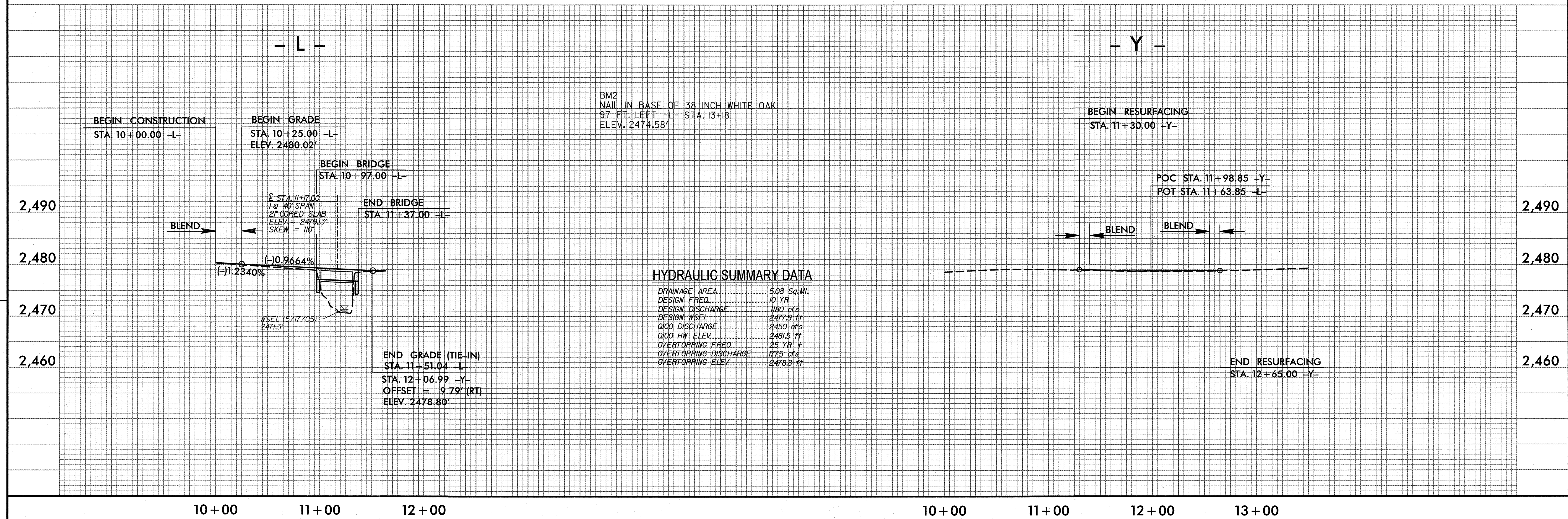

**HYDRAULIC SUMMARY DATA**

DRAINAGE AREA	5.08 Sq. Mi.
DESIGN FREQ.	10 YR
DESIGN DISCHARGE	1180 cfs
DESIGN WSEL	2477.9 ft
Q100 DISCHARGE	2450 cfs
Q100 HW ELEV.	2481.5 ft
OVERTOPPING FREQ.	25 YR +
OVERTOPPING DISCHARGE	1775 cfs
OVERTOPPING ELEV.	2478.8 ft



8/17/99

REVISIONS

PROJECT REFERENCE NO. B-3869	SHEET NO. 5
ROADWAY DESIGN ENGINEER 	HYDRAULICS ENGINEER 

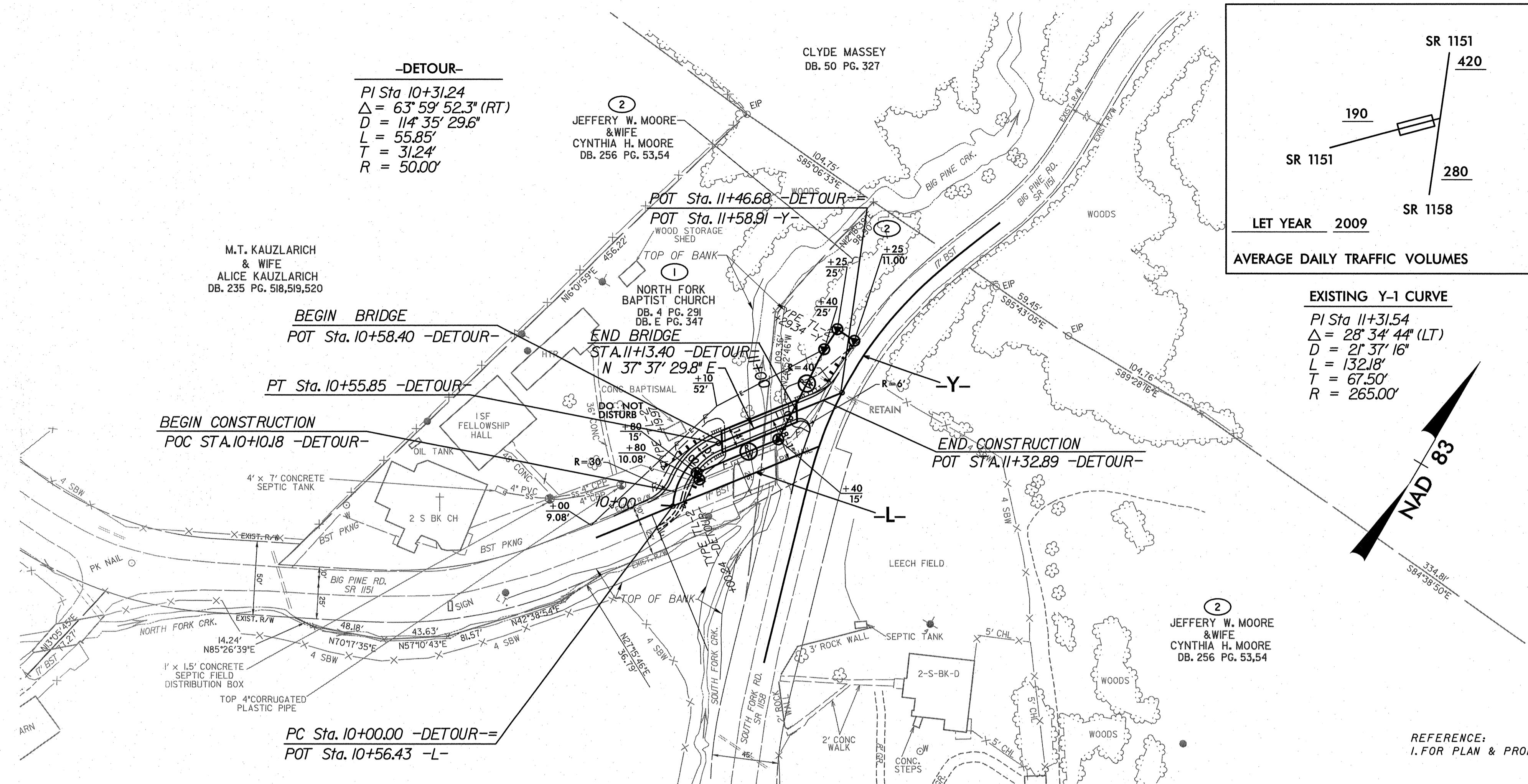

REFERENCE:  
1. FOR PLAN & PROFILE OF L-LINE, SEE SHEET NO. 4

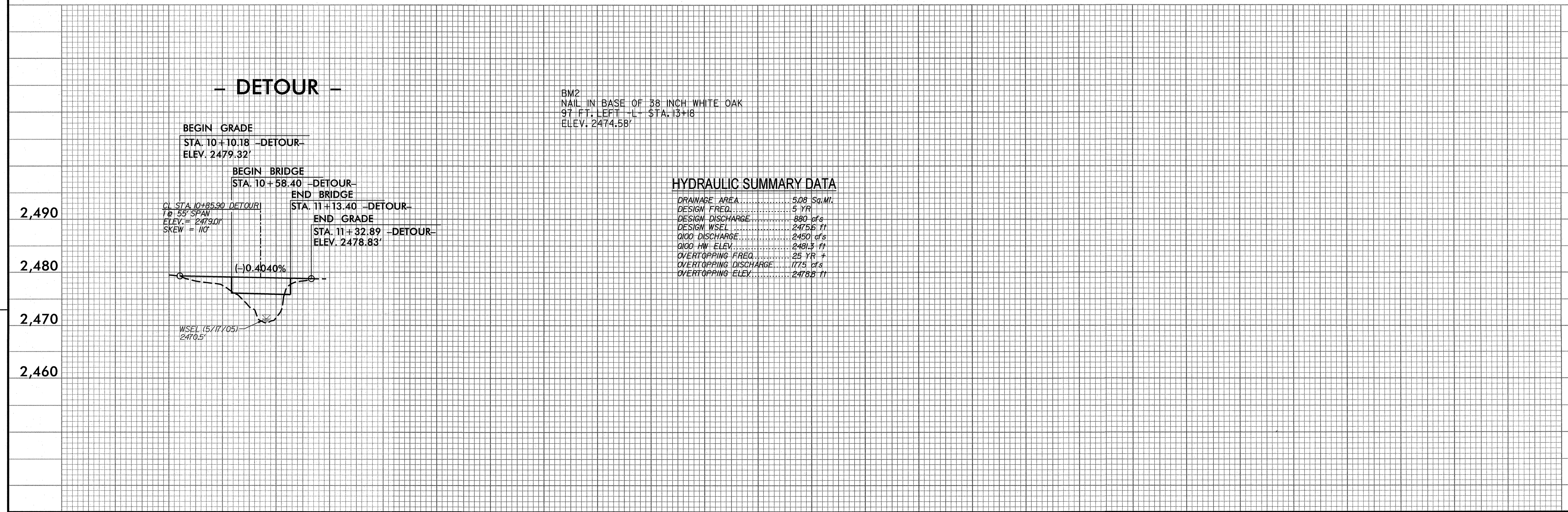

10+00      11+00      12+00