

**STATE OF NORTH CAROLINA  
DEPARTMENT OF TRANSPORTATION**

**PAVEMENT MARKING PLAN**

**CUMBERLAND COUNTY**

**LOCATION: NC 210 (MURCHISON ROAD) FROM FAYETTEVILLE OUTER LOOP  
TO JUST NORTH OF HONEYCUTT RD.**

TIP NO. U-4444AA	SHEET NO. PMP-1
APPROVED: <i>[Signature]</i>	
DATE: 6/18/09	
SEAL 	

**CONTRACT: C202178 T.I.P.: U-4444AA**

**ROADWAY STANDARD DRAWING**

THE FOLLOWING ROADWAY STANDARDS AS APPEAR IN "ROADWAY STANDARD DRAWINGS" - PROJECT SERVICES UNIT - N.C. DEPARTMENT OF TRANSPORTATION - RALEIGH, N.C., DATED JULY 2006 ARE APPLICABLE TO THIS PROJECT AND BY REFERENCE HEREBY ARE CONSIDERED A PART OF THESE PLANS:

STD. NO.	TITLE
1205.01	PAVEMENT MARKINGS - LINE TYPES AND OFFSETS
1205.02	PAVEMENT MARKINGS - 2 LANE AND MULTILANE ROADWAYS
1205.03	PAVEMENT MARKINGS - INTERCHANGES
1205.04	PAVEMENT MARKINGS - INTERSECTIONS
1205.05	PAVEMENT MARKINGS - TURN LANES
1205.06	PAVEMENT MARKINGS - THRU LANE DROPS
1205.08	PAVEMENT MARKINGS - SYMBOL AND WORD MESSAGES
1205.09	PAVEMENT MARKINGS - PAINTED ISLANDS
1205.11	PAVEMENT MARKINGS - RAILROAD CROSSINGS
1250.01	PAVEMENT MARKER SPACING
1253.01	SNOWPLOWABLE RAISED PAVEMENT MARKERS
1261.01	GUARDRAIL AND BARRIER DELINEATOR SPACING
1261.02	GUARDRAIL AND BARRIER DELINEATOR TYPES
1262.01	GUARDRAIL END DELINEATION
1264.01	OBJECT MARKERS
1264.02	PLACEMENT OF OBJECT MARKERS

**GENERAL NOTES**

THE FOLLOWING GENERAL NOTES APPLY AT ALL TIMES FOR THE DURATION OF THE CONSTRUCTION PROJECT, EXCEPT WHEN OTHERWISE NOTED IN THE PLAN, OR DIRECTED BY THE ENGINEER.

A) INSTALL PAVEMENT MARKINGS AND PAVEMENT MARKERS ON THE FINAL SURFACE AS FOLLOWS:

ROAD NAME	MARKING	MARKER
1) NC 87-210 MURCHISON RD. (ROADWAY)	THERMOPLASTIC	SNOWPLOWABLE
NC 87-210 MURCHISON RD. (BRIDGE DECK)	TYPE 2 COLD APPLIED PLASTIC	SNOWPLOWABLE
2) HONEYCUTT RD.	THERMOPLASTIC	SNOWPLOWABLE

B) TIE PROPOSED PAVEMENT MARKING LINES TO EXISTING PAVEMENT MARKING LINES.

C) REMOVE/REPLACE ANY CONFLICTING/DAMAGED PAVEMENT MARKINGS AND MARKERS.

**INDEX**

SHEET NO.	DESCRIPTION
PMP-1	PAVEMENT MARKING PLAN TITLE SHEET
PMP-2	PAVEMENT MARKING SCHEDULE
PMP-3 TO PMP-9	PAVEMENT MARKING DETAIL

**PLAN PREPARED BY: N.C.D.O.T. SIGNING AND DELINEATION UNIT**

<i>Ayman I. Alqudwah, P.E.</i>	SIGNING & DELINEATION REGIONAL ENGINEER
<i>M. Dale Stokes</i>	SIGNING & DELINEATION PROJECT DESIGN ENGINEER/TECHNICIAN

## FINAL PAVEMENT MARKING SCHEDULE

SYMBOL	DESCRIPTION	PAY ITEM QUANTITY	TOTAL QUANTITY
<b>PAVEMENT MARKINGS</b>			
THERMOPLASTIC(4", 90 MILS)			
TA	WHITE EDGELINE	4617 LF	
TB	YELLOW EDGELINE	1171 LF	
		TOTAL	5788 LF
THERMOPLASTIC(4", 120 MILS)			
TC	10 FT. WHITE SKIP	2373 LF	
TD	2 FT. WHITE MINISKIP	556 LF	
TE	WHITE SOLID LANE LINE	1303 LF	
TI	YELLOW DOUBLE CENTER	3862 LF	
		TOTAL	8094 LF
THERMOPLASTIC(6", 90 MILS)			
T6	WHITE EDGELINE	20576 LF	
T7	YELLOW EDGELINE	21624 LF	
		TOTAL	42200 LF
THERMOPLASTIC(6", 120 MILS)			
TJ	10 FT. WHITE SKIP	9948 LF	
TK	2 FT. WHITE MINISKIP	859 LF	
TL	WHITE SOLID LANE LINE	774 LF	
		TOTAL	11581 LF
THERMOPLASTIC(8", 90 MILS)			
TP	WHITE GORELINE	754 LF	
TQ	WHITE DIAGONAL	121 LF	
TT	YELLOW DIAGONAL	875 LF	
		TOTAL	1750 LF
THERMOPLASTIC(12", 90 MILS)			
TY	WHITE GORELINE	2765 LF	
		TOTAL	2765 LF
THERMOPLASTIC(16", 120 MILS)			
T1	WHITE LINE, RR CROSSB	138 LF	
		TOTAL	138 LF
THERMOPLASTIC(24", 120 MILS)			
T2	WHITE STOPBAR	533 LF	
		TOTAL	533 LF
THERMOPLASTICPAVEMENT MARKING CHARACTER (120 MILS)			
UI	ALPHANUMERIC CHAR.	22 EA	
		TOTAL	22 EA
THERMOPLASTICPAVEMENT MARKING SYMBOLS (90 MILS)			
UA	LEFT TURN ARROW	42 EA	
UB	RIGHT TURN ARROW	22 EA	
UC	STRAIGHT ARROW	53 EA	
		TOTAL	117 EA
COLD APPLIED PLASTIC (6") TYPE 2 - PERMANENT HIGH PERFORMANCE			
C6	WHITE EDGELINE	520 LF	
C7	YELLOW EDGELINE	520 LF	
CK	10 FT. WHITE SKIP	370 LF	
CL	2 FT. WHITE MINISKIP	11 LF	
		TOTAL	1421 LF
<b>MARKERS</b>			
SNOWPLOWABLE RAISED PAVEMENT MARKERS			
ME	YELLOW & YELLOW	52 EA	
MF	CRYSTAL & RED	940 EA	
		TOTAL	992 EA

TIP NO. U-4444AA	SHEET NO. PMP-2
APPROVED:	
DATE: 6/18/09	
SEAL  NORTH CAROLINA PROFESSIONAL SEAL 028387 ENGINEER AHMAD I. ALQUOBI	

I8-JUN-2009 07:21 \\dot\dfs010\pco\Tjpr\projects-u\4444aa\Traffic\signing\cadd\pmp\U-4444AA\_SGNL\_PMP\_2.dgn

TIP NO. U-4444AA	SHEET NO. PMP-3
APPROVED: <i>[Signature]</i> DATE: 6/2/09	
SEAL 	

PAVEMENT MARKING LEGEND	
(T6)	WHITE EDGE LINE (6")
(T7)	YELLOW EDGE LINE (6")
(TJ)	WHITE SKIP LINE (6")

BEGIN PROJECT  
-L- STA. 24+05+/-

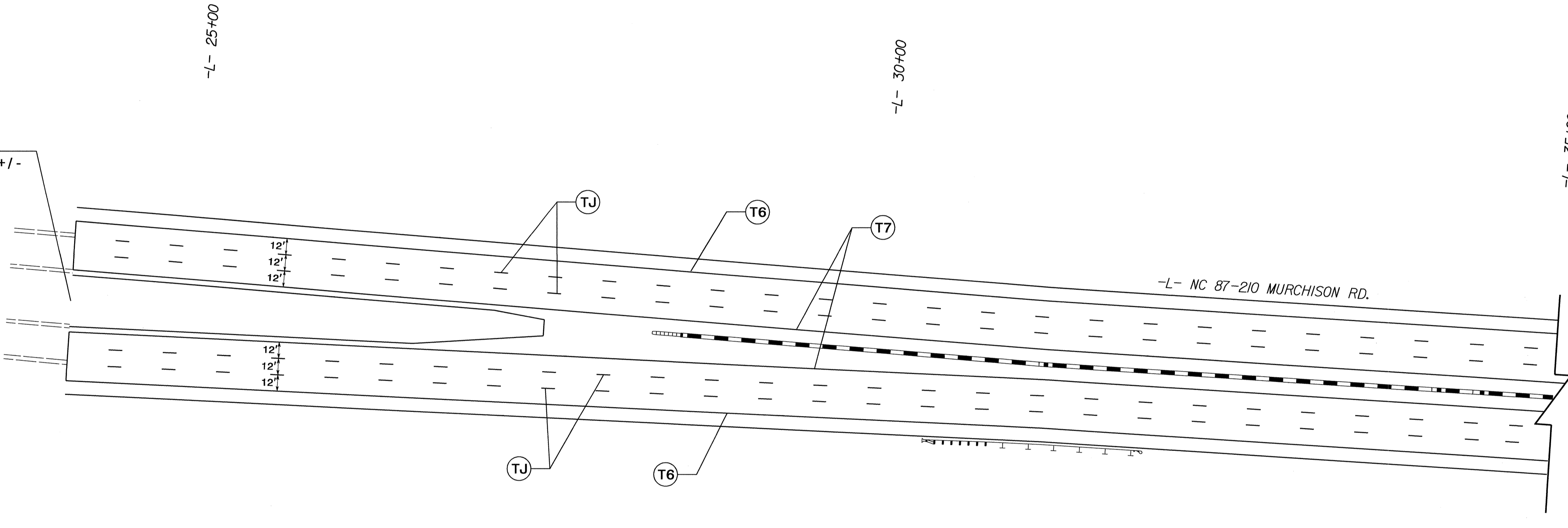

BREAKLINE -L- STA. 35+00  
SEE PMP-4

NOTES:  
1. UNLESS OTHERWISE SHOWN ON DRAWING, SEE 2006 NC DOT ROADWAY STANDARD DRAWINGS 1205.01 AND 1205.02 FOR PAVEMENT MARKING LOCATIONS AND 1250.01 FOR SNOWPLOWABLE PAVEMENT MARKER LOCATIONS.

PAVEMENT MARKING DETAIL

18-JUN-2009 07:33  
C:\dot\rd\87-210\pmp\projects\4444aa\traffic\signing\cadd\pmp\U-4444AA\_SGN\_PMP\_3.dgn  
astokes AI WZTC244745

**PAVEMENT MARKING LEGEND**

- (T6) WHITE EDGE LINE (6")
- (T7) YELLOW EDGE LINE (6")
- (TJ) WHITE SKIP LINE (6")

TIP NO. U-4444AA	SHEET NO. PMP-4
---------------------	--------------------

APPROVED: *[Signature]*  
DATE: 6/18/09

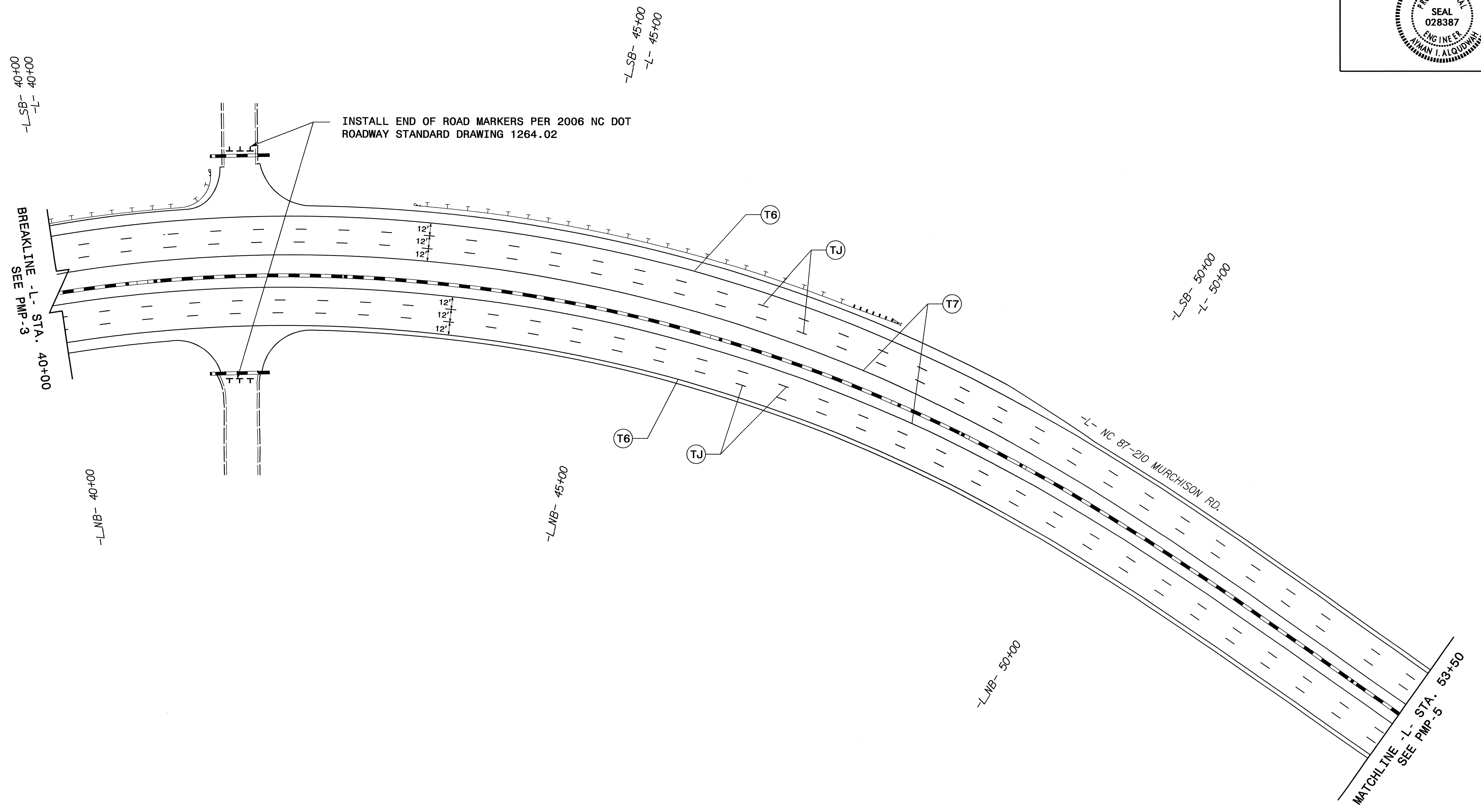
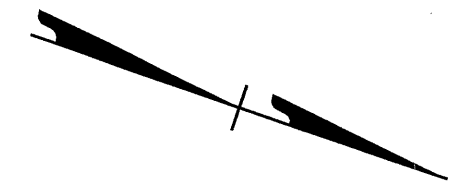

**NOTES:**

- UNLESS OTHERWISE SHOWN ON DRAWING, SEE 2006 NC DOT ROADWAY STANDARD DRAWINGS 1205.01 AND 1205.02 FOR PAVEMENT MARKING LOCATIONS AND 1250.01 FOR SNOWPLOWABLE PAVEMENT MARKER LOCATIONS.



**PAVEMENT MARKING DETAIL**

I8-JUN-2009 07:34 \\dot\dfs\0010\pco\proj\projects-u\4444aa\traffic\signing\cadd\pmp\U-4444AA\_SGNL\_PMP\_4.dgn





TIP NO. U-4444AA	SHEET NO. PMP-7
APPROVED: <i>[Signature]</i>	
DATE: 6/18/09	
SEAL	
	

SYMBOL AND PAVEMENT MARKING LEGEND	
 (UA) LEFT TURN ARROW	(TA) WHITE EDGE LINE (4")
 (UC) STRAIGHT ARROW	(TB) YELLOW EDGE LINE (4")
	(TC) WHITE SKIP LINE (4")
	(TD) 2 FT. WHITE MINISKIP (4")
	(TE) WHITE SOLID LANE LINE (4")
	(TI) YELLOW DOUBLE CENTER (4")
	(TT) YELLOW DIAGONAL (8")

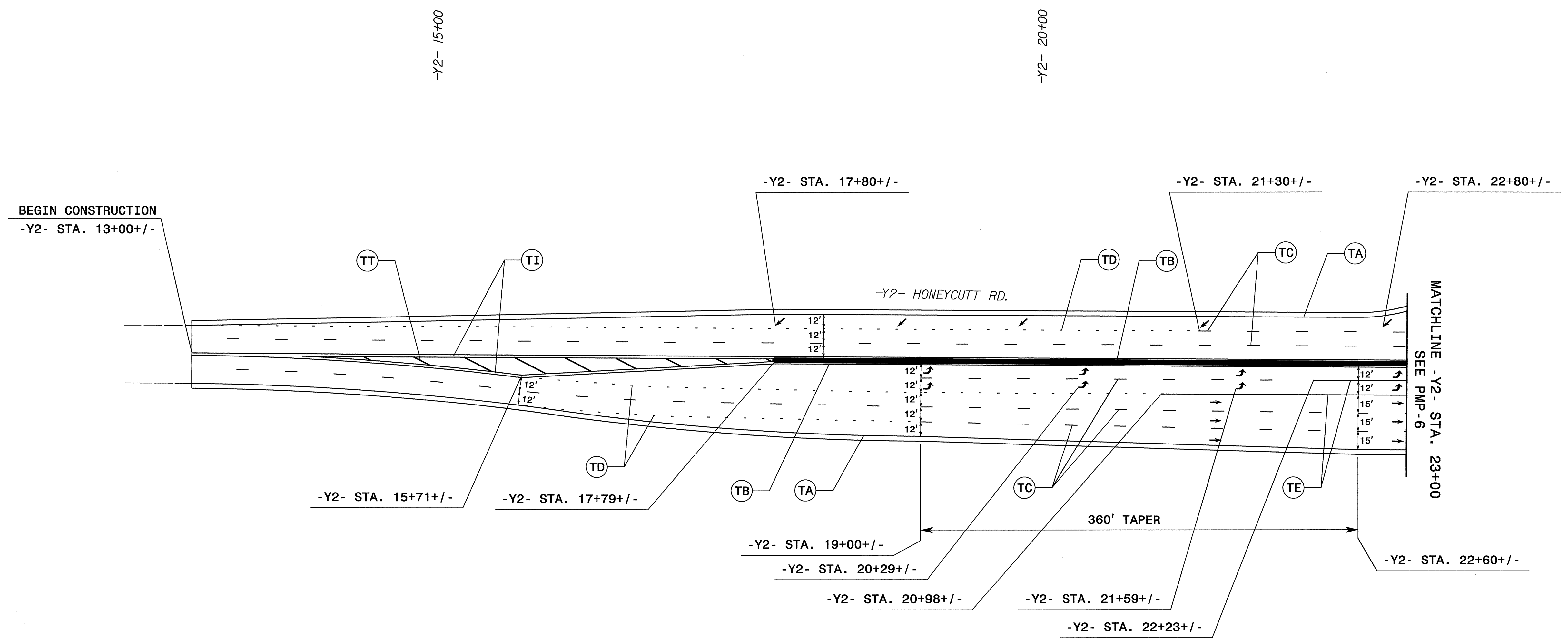

NOTES:

- UNLESS OTHERWISE SHOWN ON DRAWING, SEE 2006 NC DOT ROADWAY STANDARD DRAWINGS 1205.01, 1205.02, 1205.04, 1205.05, 1205.06, 1205.08, 1205.09 FOR PAVEMENT MARKING AND SYMBOL LOCATIONS AND 1250.01 FOR SNOWPLOWABLE PAVEMENT MARKER LOCATIONS.

**PAVEMENT MARKING DETAIL**

I8-JUN-2009 07:42 \\dot\dfs\p04\01\pco\11\p\projects-u\4444aa\traffic\signing\codd\pmp\U-4444AA\_SGNL\_PMP\_7.dgn

TIP NO. U-4444AA	SHEET NO. PMP-8A
APPROVED: <i>[Signature]</i>	
DATE: 6/18/09	
SEAL	

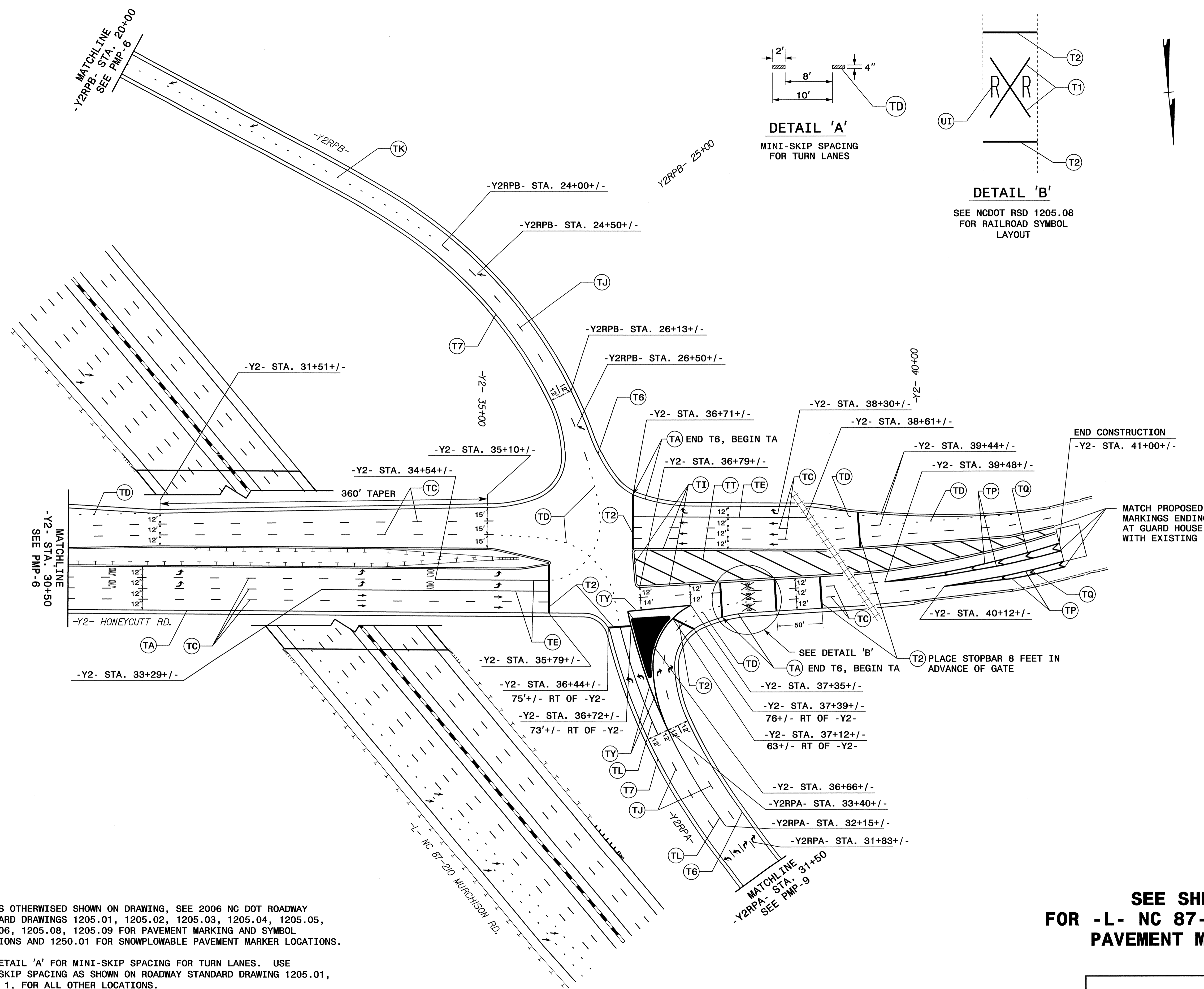

SYMBOL AND PAVEMENT MARKING LEGEND	
	(UA) LEFT TURN ARROW
	(UB) RIGHT TURN ARROW
	(UC) STRAIGHT ARROW
ONLY, RR	(UI) ALPHANUMERIC CHARACTER
THERMOPLASTIC	
(TA)	WHITE EDGE LINE (4")
(TB)	YELLOW EDGE LINE (4")
(TC)	WHITE SKIP LINE (4")
(TD)	2 FT. WHITE MINISKIP (4") (SEE NOTE 2)
(TE)	WHITE SOLID LANE LINE (4")
(TI)	YELLOW DOUBLE CENTER (4")
(TJ)	WHITE SKIP LINE (6")
(TK)	2 FT. WHITE MINISKIP (6")
(TL)	WHITE SOLID LANE LINE (6")
(TP)	WHITE GORE LINE (8")
(TQ)	WHITE DIAGONAL (8")
(TY)	WHITE GORE LINE (12")
(TT)	YELLOW DIAGONAL (8")
(T1)	WHITE LINE RR X (16")
(T2)	WHITE STOPBAR (24")
(T6)	WHITE EDGE LINE (6")
(T7)	YELLOW EDGE LINE (6")

- NOTES:
- UNLESS OTHERWISE SHOWN ON DRAWING, SEE 2006 NC DOT ROADWAY STANDARD DRAWINGS 1205.01, 1205.02, 1205.03, 1205.04, 1205.05, 1205.06, 1205.08, 1205.09 FOR PAVEMENT MARKING AND SYMBOL LOCATIONS AND 1250.01 FOR SNOWPLOWABLE PAVEMENT MARKER LOCATIONS.
  - SEE DETAIL 'A' FOR MINI-SKIP SPACING FOR TURN LANES. USE MINI-SKIP SPACING AS SHOWN ON ROADWAY STANDARD DRAWING 1205.01, SHEET 1, FOR ALL OTHER LOCATIONS.

**SEE SHEET PMP-8B  
FOR -L- NC 87-210 MURCHISON RD.  
PAVEMENT MARKING DETAIL**

**PAVEMENT MARKING DETAIL**

I8-JUN-2009 07:51 \\dot\dfs\p00\0\pco\proj\projects-u\4444aa\traff\signing\cadd\pmp\U-4444AA\_SGNL\_PMP\_8A.dgn



TIP NO. U-4444AA	SHEET NO. PMP-8B
APPROVED: <i>[Signature]</i>	
DATE: 6/18/09	
SEAL 	

**SYMBOL AND PAVEMENT MARKING LEGEND**

↑ UC STRAIGHT ARROW

**THERMOPLASTIC**

- (TJ) WHITE SKIP LINE (6")
- (TK) 2 FT. WHITE MINISKIP (6")
- (T6) WHITE EDGE LINE (6")
- (T7) YELLOW EDGE LINE (6")

**TYPE 2 COLD APPLIED PLASTIC (FOR BRIDGE DECK ONLY)**

- (C6) WHITE EDGE LINE (6")
- (C7) YELLOW EDGE LINE (6")
- (CK) WHITE SKIP LINE (6")
- (CL) 2 FT. WHITE MINISKIP (6")

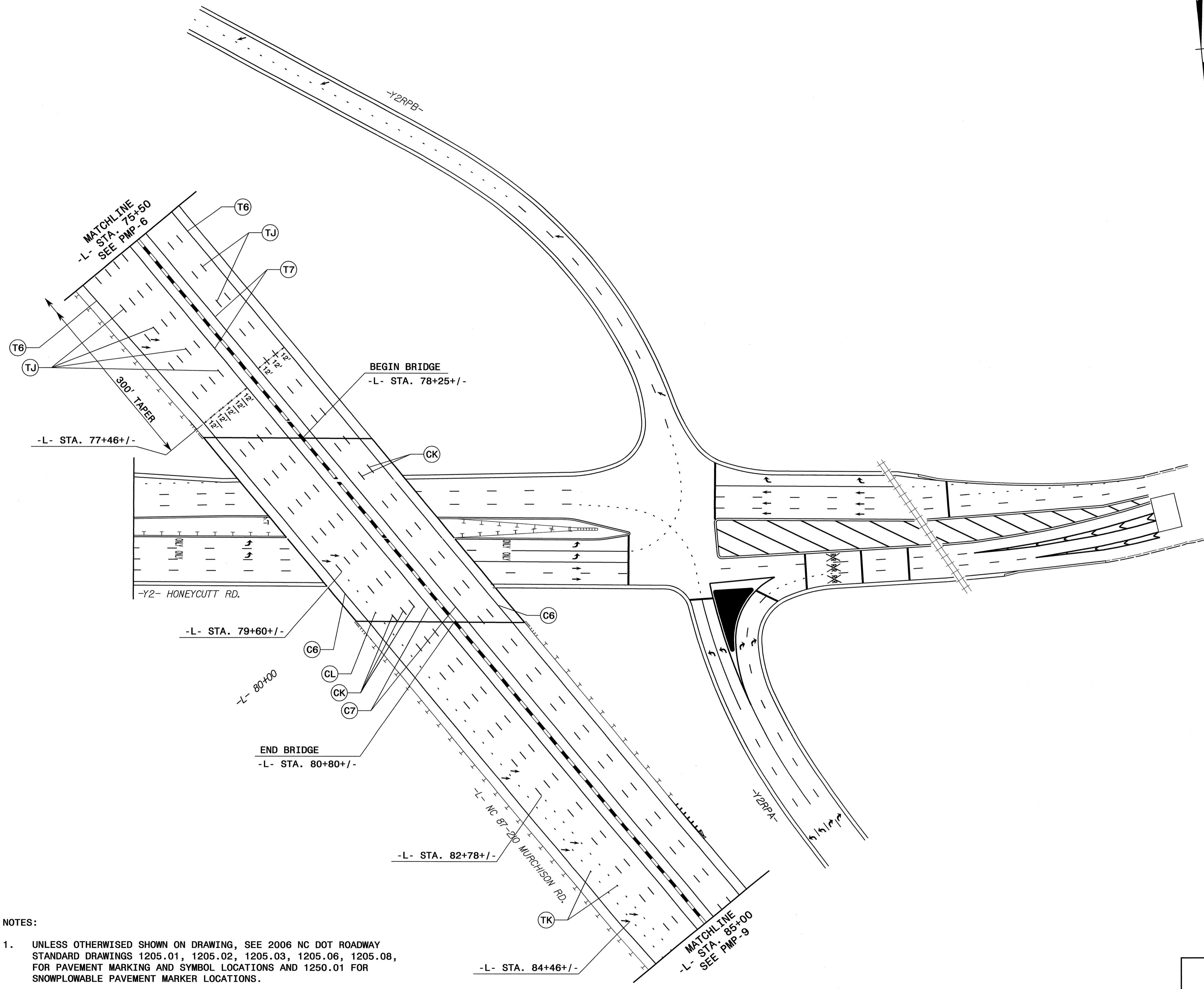

- NOTES:**
- UNLESS OTHERWISE SHOWN ON DRAWING, SEE 2006 NC DOT ROADWAY STANDARD DRAWINGS 1205.01, 1205.02, 1205.03, 1205.06, 1205.08, FOR PAVEMENT MARKING AND SYMBOL LOCATIONS AND 1250.01 FOR SNOWPLOWABLE PAVEMENT MARKER LOCATIONS.

**SEE SHEET PMP-8A  
FOR -Y2- HONEYCUTT RD  
PAVEMENT MARKING DETAIL**







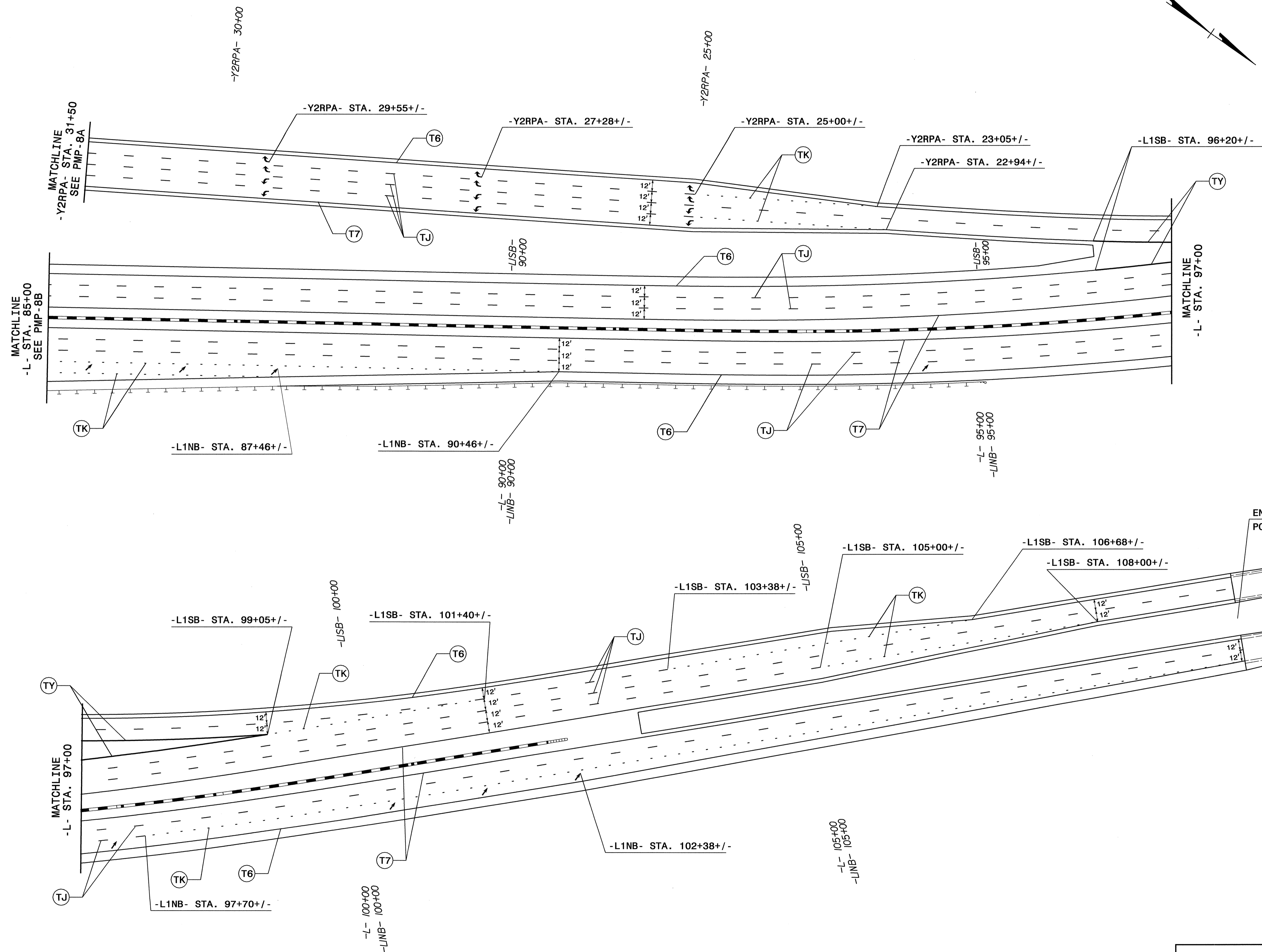

**PAVEMENT MARKING DETAIL**

I8-JUN-2009 07:52  
 \\dot\dfs\p010\proj\projects-u\4444aa\Traffic\Signing\CADD\PMP-U-4444AA\_SGN.PMP\_8B.dgn  
 dstokes AI WZTC244745

TIP NO. U-4444AA	SHEET NO. PMP-9
APPROVED: <i>[Signature]</i>	
DATE: 6/18/09	
SEAL	
	

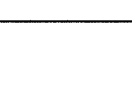

**SYMBOL AND PAVEMENT MARKING LEGEND**

	(UA) LEFT TURN ARROW
	(UB) RIGHT TURN ARROW
	(UC) STRAIGHT ARROW
	(TJ) WHITE SKIP LINE (6")
	(TK) 2 FT. WHITE MINISKIP (6")
	(TL) WHITE SOLID LANE LINE (6")
	(TY) WHITE GORE LINE (12")
	(T6) WHITE EDGE LINE (6")
	(T7) YELLOW EDGE LINE (6")

**NOTES:**

- UNLESS OTHERWISE SHOWN ON DRAWING, SEE 2006 NC DOT ROADWAY STANDARD DRAWINGS 1205.01, 1205.02, 1205.03, 1205.06, 1205.08, FOR PAVEMENT MARKING AND SYMBOL LOCATIONS AND 1250.01 FOR SNOWPLOWABLE PAVEMENT MARKER LOCATIONS.

**PAVEMENT MARKING DETAIL**

18-JUN-2009 07:54  
 \\dot\dfs00\0\pco\proj\projects-u\4444aa\Traffic\Signing\CADD\PMP-U-4444AA\_SGNL\_PMP\_9.dgn  
 dstroke - AT: MZTC244745