

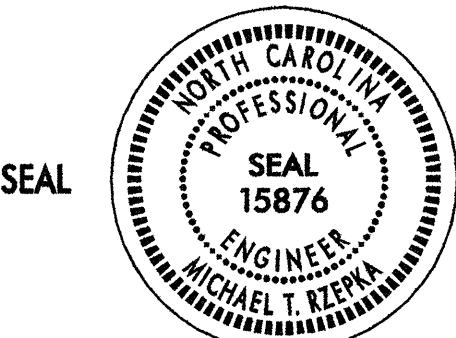

FINAL PAVEMENT MARKING SCHEDULE

SYMBOL	DESCRIPTION	QUANTITY BREAKDOWN	PAY ITEM	TOTAL QUANTITY
PAVEMENT MARKING LINES				
			THERMOPLASTIC (4", 90 mils)	
TA	WHITE EDGE LINE	6,215 LF		
TB	YELLOW EDGE LINE	6,103 LF		
			TOTAL	12,318 LF
			THERMOPLASTIC (4", 120 mils)	
TC	10 FT WHITE SKIP	2,349 LF		
TD	2 FT WHITE MINISKIP	676 LF		
TE	WHITE SOLID LANE LINE	5,709 LF		
TI	YELLOW DOUBLE CENTER LINE	10,950 LF		
			TOTAL	19,684 LF
			THERMOPLASTIC (8", 90 mils)	
TP	WHITE GORE LINE	636 LF		
TQ	WHITE DIAGONAL	314 LF		
TT	YELLOW DIAGONAL	556 LF		
			TOTAL	1,506 LF
			THERMOPLASTIC (8", 120 mils)	
TV	WHITE CROSSWALK LINE	2,104 LF		
			TOTAL	2,104 LF
			THERMOPLASTIC (24", 120 mils)	
T2	WHITE STOP BAR	1,284 LF		
			TOTAL	1,284 LF
PAVEMENT MARKING SYMBOLS				
			THERMOPLASTIC THICK SYMBOL (90 mils)	
UA	LEFT TURN ARROW	49 EA		
UB	RIGHT TURN ARROW	33 EA		
UC	STRAIGHT ARROW	45 EA		
UD	COMBO STRAIGHT & LEFT TURN ARROW	4 EA		
UE	COMBO STRAIGHT & RIGHT TURN ARROW	10 EA		
			TOTAL	141 EA
			THERMOPLASTIC THICK CHARACTER (120 mils)	
UI	ALPHANUMERIC CHARACTER	4 EA		
			TOTAL	4 EA
PAVEMENT MARKERS				
			SNOWPLOWABLE RAISED	
ME	YELLOW AND YELLOW	186 EA		
MF	CRYSTAL AND RED	470 EA		
			TOTAL	656 EA

SEE ROADWAY STANDARD DRAWING NUMBERS 1205.01, 1205.02, 1205.04, 1205.05, 1205.06, 1205.07, 1205.08, 1205.09, 1250.01, 1253.01, 1267.01, 1267.02, 1267.03

APPROVED: <i>Michael T. Kiepa</i>	DATE: 11-26-08	FINAL PAVEMENT MARKING SCHEDULE	
	SCALE: NONE		REVISIONS
	DATE: 11-08		
	DWG. BY: BLM		
	DESIGN BY: GEP		
REVIEWED BY: MTR			

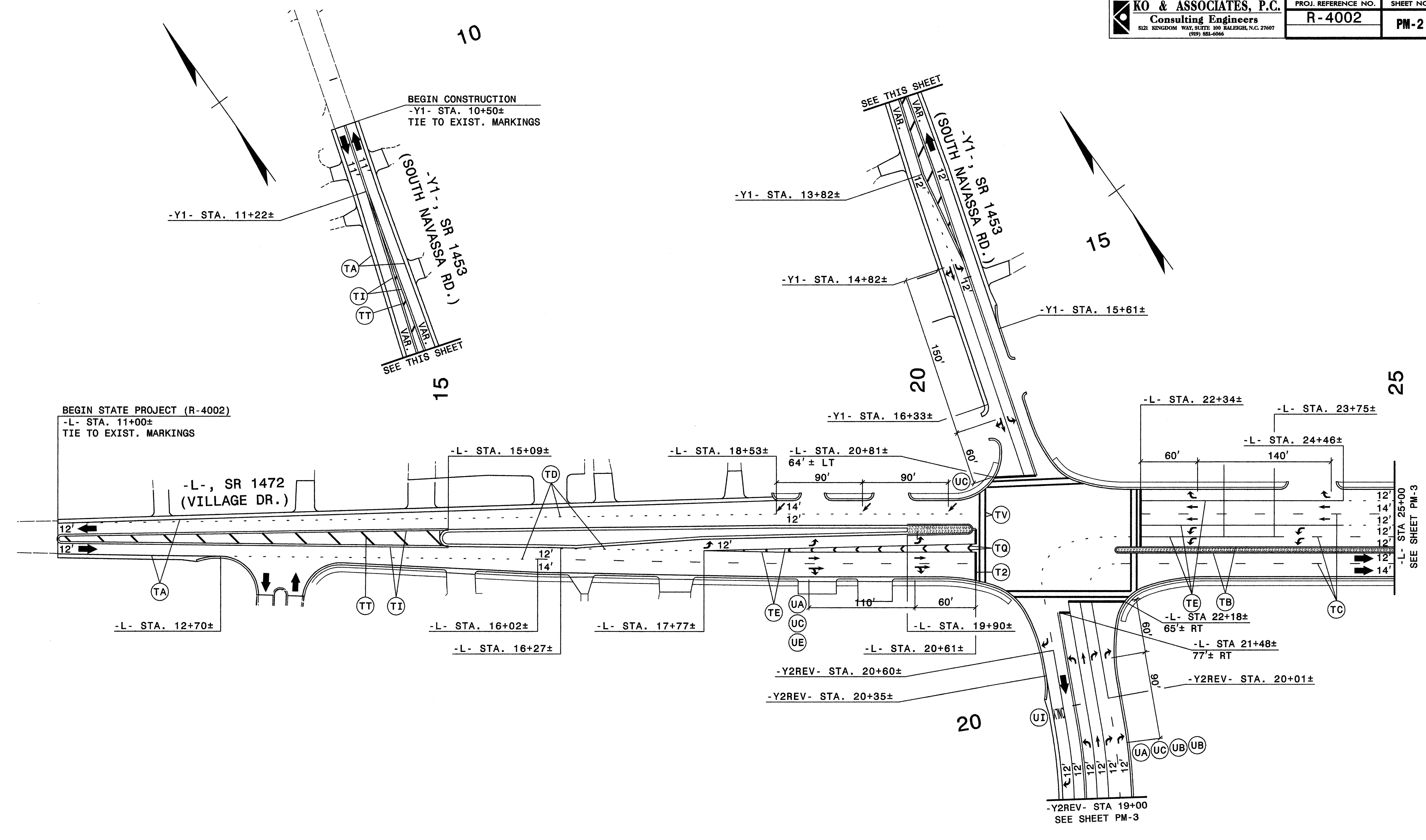

NOTES:

- SEE SHEET PM-1 FOR FINAL PAVEMENT MARKING SCHEDULE.
- PAVEMENT MARKINGS, SYMBOLS, AND CHARACTERS TO BE MARKED ACCORDING TO ROADWAY STANDARD DRAWINGS UNLESS OTHERWISE NOTED IN THE PLANS.
- PAVEMENT MARKERS ARE TO BE SPACED ACCORDING TO THE ROADWAY STANDARD DRAWINGS.

APPROVED: *Michael T. Zepher* DATE: 11-26-08

SEAL

PROFESSIONAL ENGINEER
 SEAL 15876
 MICHAEL T. ZEPHER

PAVEMENT MARKING PLAN

SCALE: NONE
 DATE: 11-08
 DWG. BY: BLM
 DESIGN BY: GEP
 REVIEWED BY: MTR

REVISIONS

NO.	DESCRIPTION

CADD FILE

R:\0001\4002-1c_top_pm2.dwg
 11/25/2008 4:06:59 PM

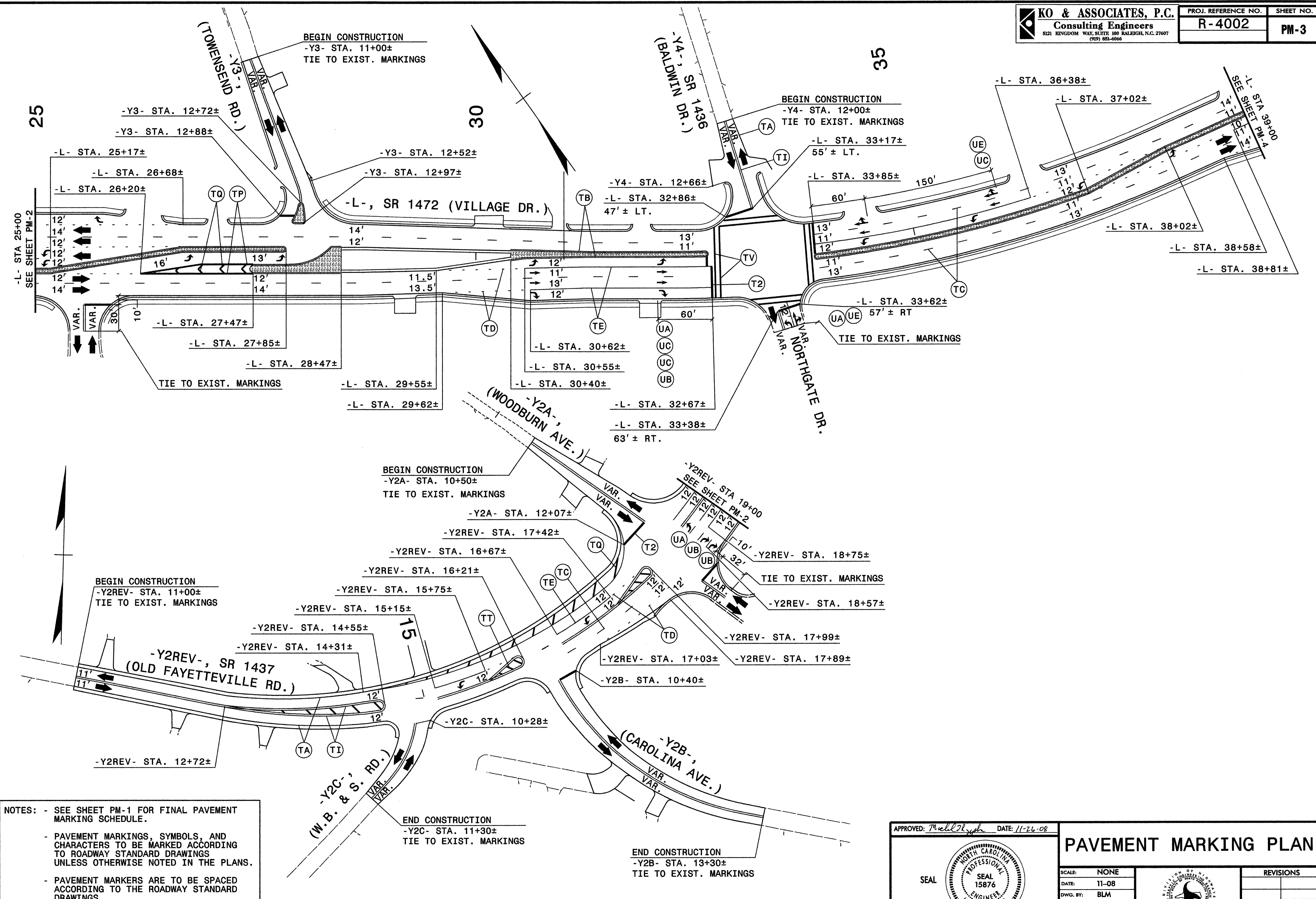

NOTES:

- SEE SHEET PM-1 FOR FINAL PAVEMENT MARKING SCHEDULE.
- PAVEMENT MARKINGS, SYMBOLS, AND CHARACTERS TO BE MARKED ACCORDING TO ROADWAY STANDARD DRAWINGS UNLESS OTHERWISE NOTED IN THE PLANS.
- PAVEMENT MARKERS ARE TO BE SPACED ACCORDING TO THE ROADWAY STANDARD DRAWINGS.

APPROVED: *Michael T. Rzepka* DATE: 11-26-08

SEAL

PAVEMENT MARKING PLAN

SCALE: NONE
 DATE: 11-08
 DWG. BY: BLM
 DESIGN BY: GEP
 REVIEWED BY: MTR

REVISIONS	

CADD FILE

R:\0070\4002_1c_14p_pm3.dgn
 11/25/2008 4:07:52 PM

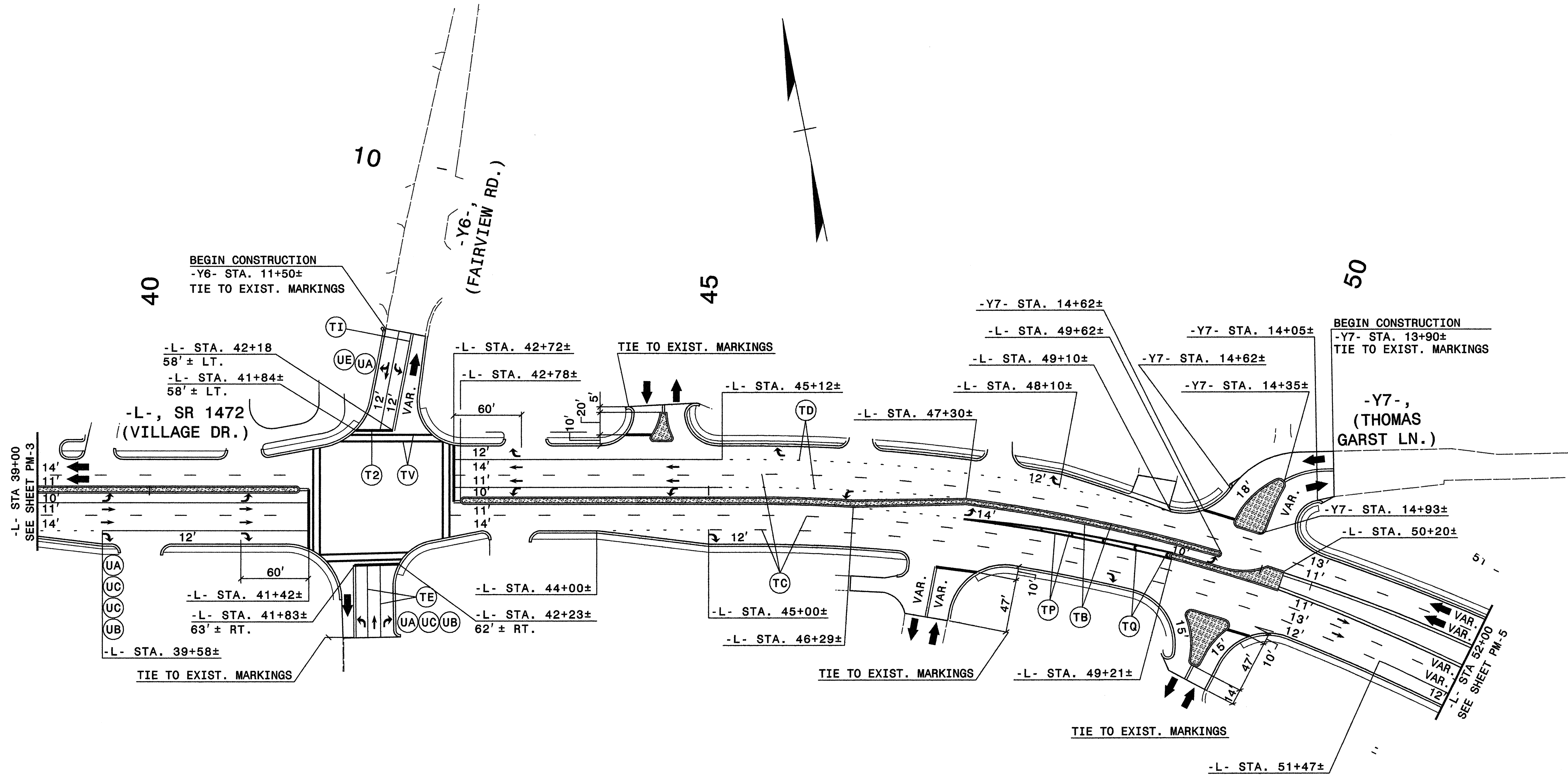

NOTES:

- SEE SHEET PM-1 FOR FINAL PAVEMENT MARKING SCHEDULE.
- PAVEMENT MARKINGS, SYMBOLS, AND CHARACTERS TO BE MARKED ACCORDING TO ROADWAY STANDARD DRAWINGS UNLESS OTHERWISE NOTED IN THE PLANS.
- PAVEMENT MARKERS ARE TO BE SPACED ACCORDING TO THE ROADWAY STANDARD DRAWINGS.

APPROVED: *[Signature]* DATE: 11-26-08

PAVEMENT MARKING PLAN

SCALE: NONE
 DATE: 11-08
 DWG. BY: BLM
 DESIGN BY: GEP
 REVIEWED BY: MTR

SEAL: *[Professional Engineer Seal: Michael T. Rzepka, License No. 15876]*

REVISIONS	

R:\002\4002\4002-1c-1p-1m4.dgn
 11/26/2008 9:45:58 AM

NOTES:

- SEE SHEET PM-1 FOR FINAL PAVEMENT MARKING SCHEDULE.
- PAVEMENT MARKINGS, SYMBOLS, AND CHARACTERS TO BE MARKED ACCORDING TO ROADWAY STANDARD DRAWINGS UNLESS OTHERWISE NOTED IN THE PLANS.
- PAVEMENT MARKERS ARE TO BE SPACED ACCORDING TO THE ROADWAY STANDARD DRAWINGS.

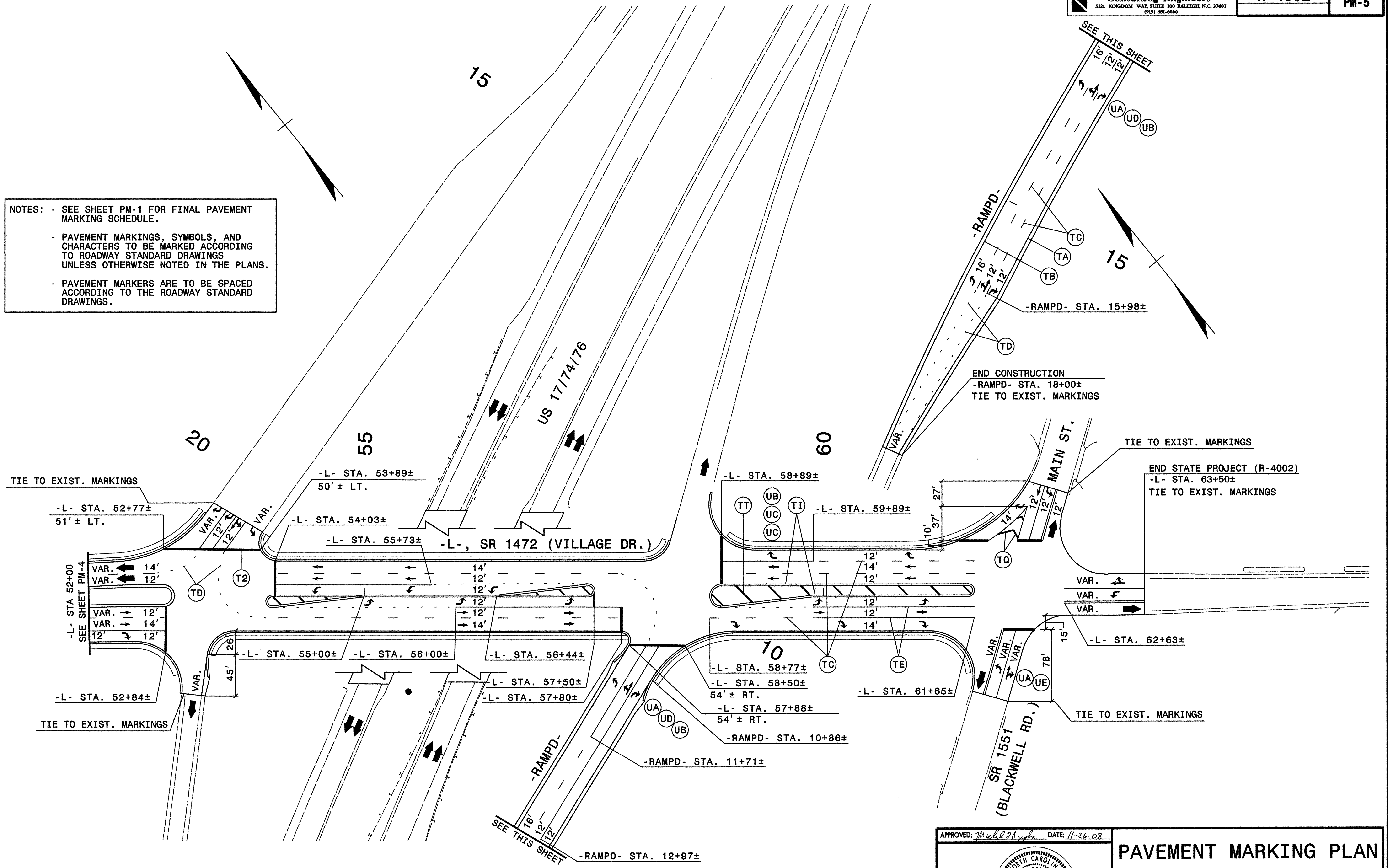

R:\002\4002-16.tbl_jmEdgjn 11/26/2008 9:53:20 AM

APPROVED: *Michael T. Kiepan* DATE: 11-26-08

SEAL

PAVEMENT MARKING PLAN

SCALE: NONE		REVISIONS <table border="1"> <tr><td> </td><td> </td></tr> <tr><td> </td><td> </td></tr> <tr><td> </td><td> </td></tr> <tr><td> </td><td> </td></tr> </table>								
DATE: 11-08										
DWG. BY: BLM										
DESIGN BY: GEP										
REVIEWED BY: MTR	CADD FILE									