

**TIP PROJECT: B-3921**

**CONTRACT: C202123**

STATE OF NORTH CAROLINA  
DIVISION OF HIGHWAYS

T.I.P. NO.	SHEET NO.
B-3921	UC-1

**UTILITY CONSTRUCTION PLANS  
WARREN COUNTY**

**LOCATION: BRIDGE NO. 45 OVER FISHING CREEK AND  
APPROACHES ON SR 1600 (BALTIMORE ROAD)**  
**TYPE OF WORK: UTILITES**

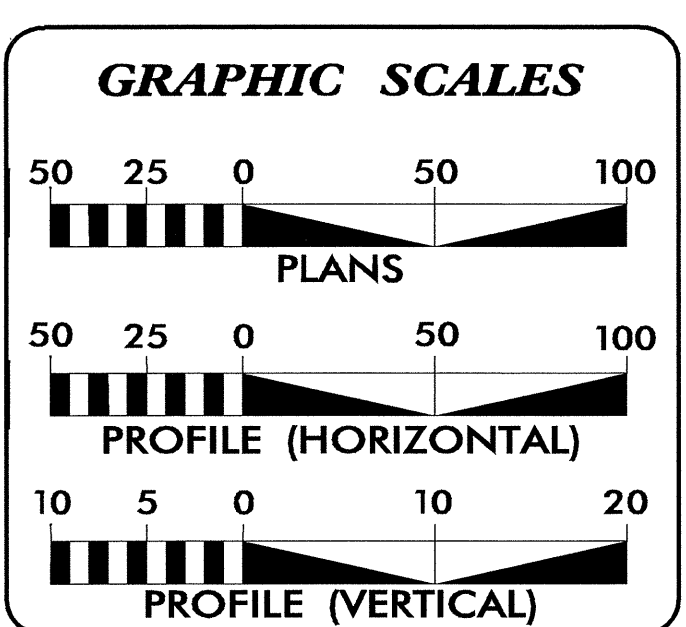
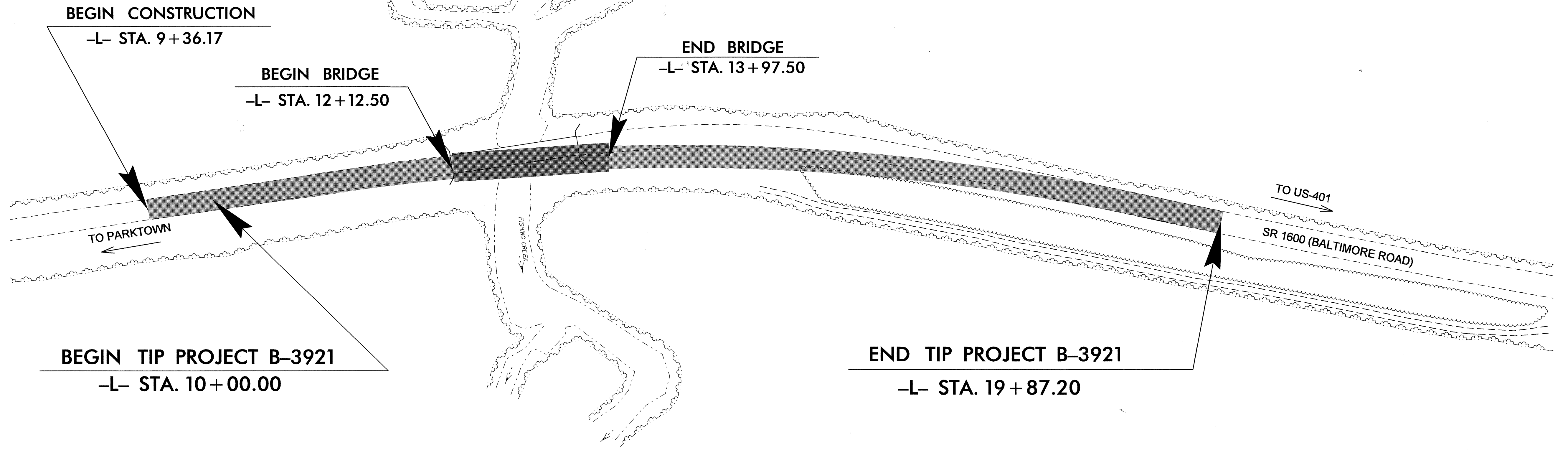
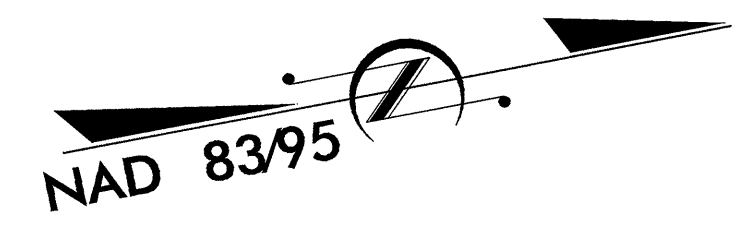
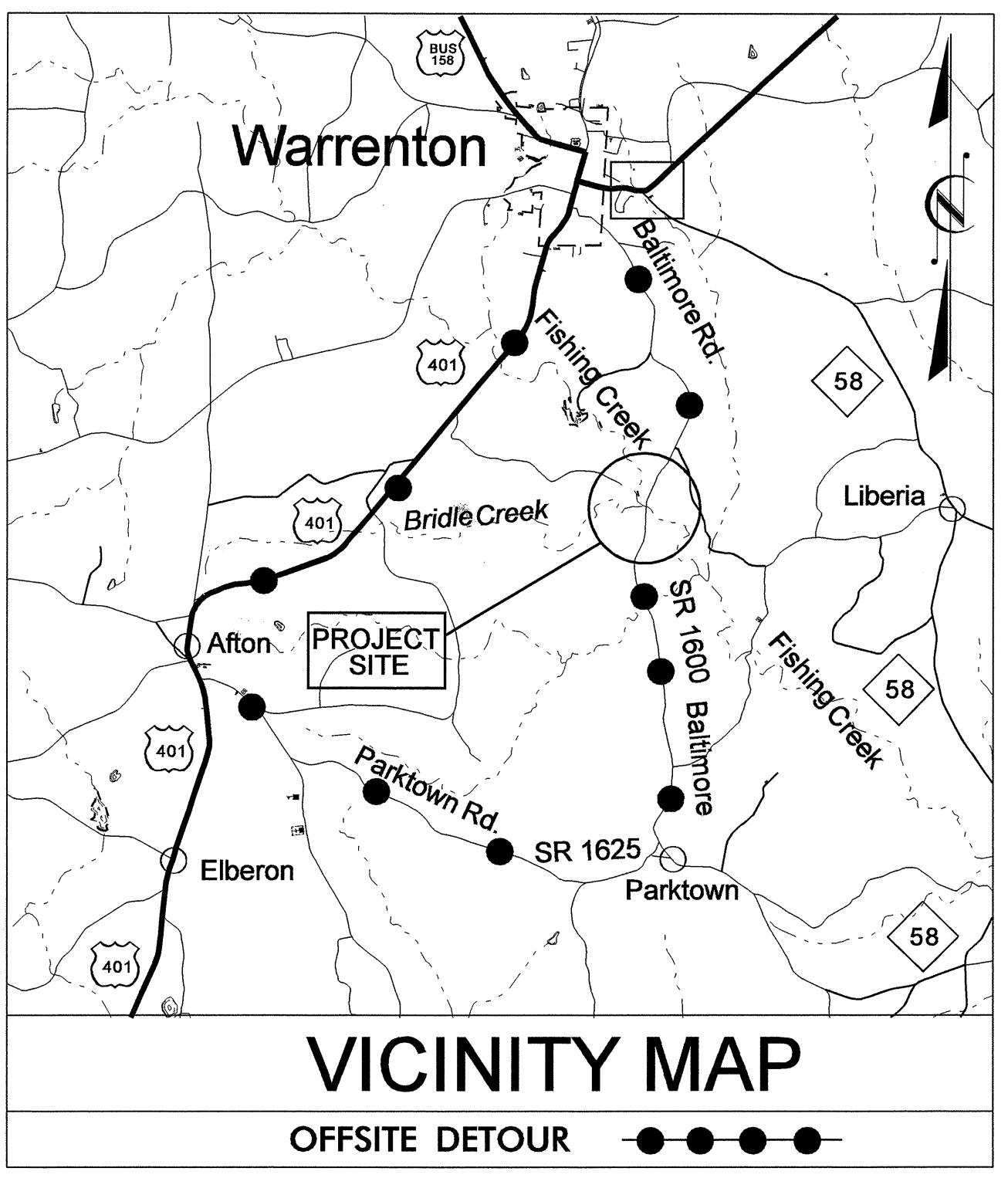

INDEX OF SHEETS	
SHEET NO.	DESCRIPTION
UC-1	TITLE SHEET
UC-2	UTILITY CONSTRUCTION PLAN SHEET
UC-3	DETAILS SHEET

**WATER AND SEWER OWNERS ON PROJECT**

(1) WATER - WARREN COUNTY PUBLIC UTILITIES

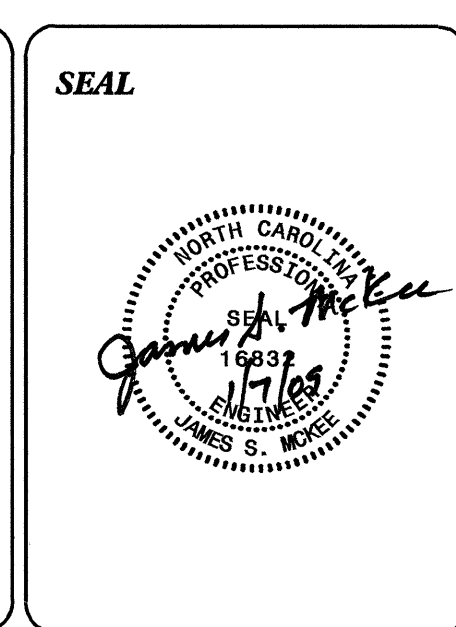

PREPARED IN THE OFFICE OF:  
**DIVISION OF HIGHWAYS  
UTILITIES ENGINEERING SECTION**

1591 MAIL SERVICES CENTER  
RALEIGH NC 27699-1591  
PHONE (919) 250-4128  
FAX (919) 250-4119

**Roger Worthington, P.E.** UTILITIES SECTION ENGINEER  
**Steve McKee, P.E.** UTILITIES SQUAD LEADER PROJECT ENGINEER  
**Donald Proper** UTILITIES PROJECT DESIGNER

UTILITY CONSTRUCTION

**NOTE:**  
 THE CONTRACTOR'S ATTENTION IS DIRECTED TO SECTIONS 1550, 102 AND 107 OF THE STANDARD SPECIFICATIONS CONCERNING THE TRENCHLESS INSTALLATION. NO DAMAGE IS ALLOWED TO THE WETLAND OR STREAM BY THE TRENCHLESS INSTALLATION. THE CONTRACTOR'S ENGINEER SHALL DESIGN THE INSTALLATION METHOD AND PROVIDE ON-SITE OVERSIGHT.

MARSHY AREA

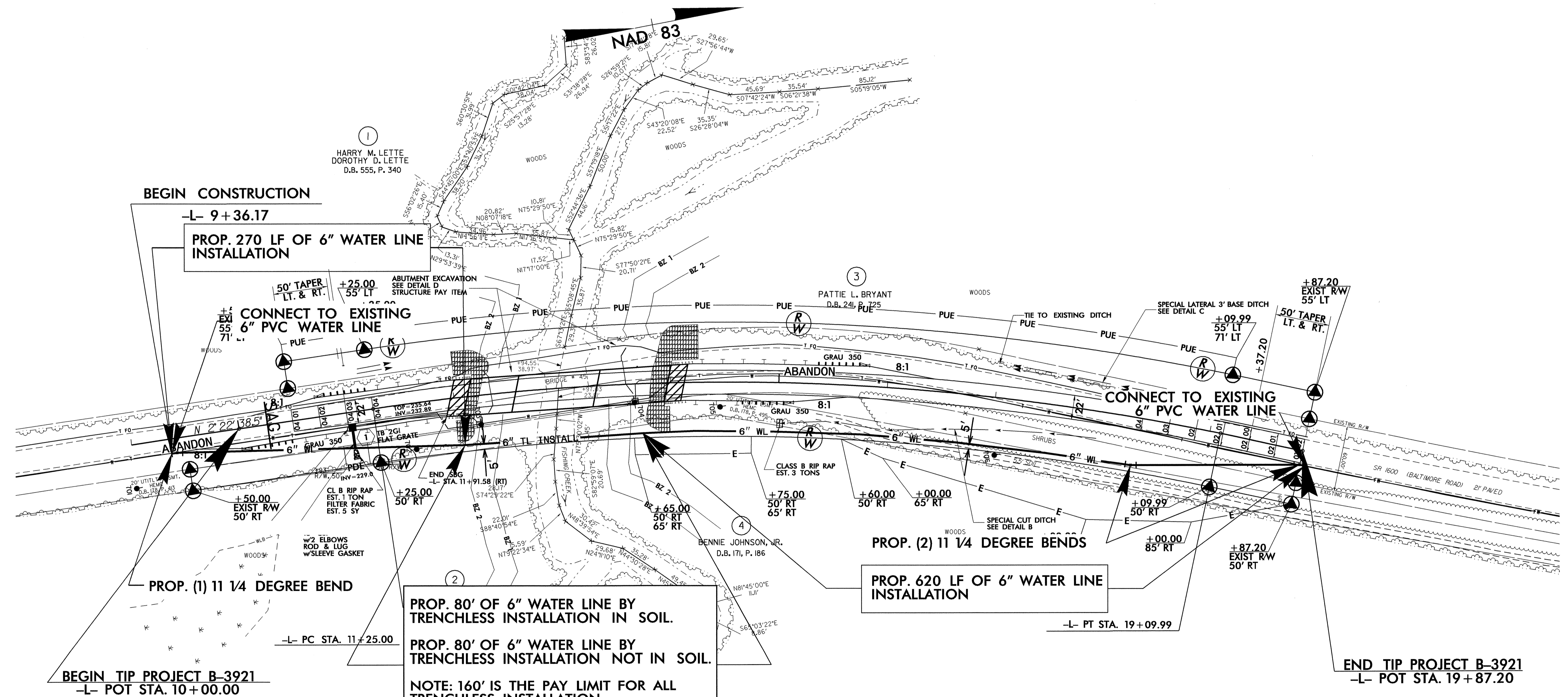

PROP. 80' OF 6" WATER LINE BY TRENCHLESS INSTALLATION IN SOIL.  
 PROP. 80' OF 6" WATER LINE BY TRENCHLESS INSTALLATION NOT IN SOIL.  
 NOTE: 160' IS THE PAY LIMIT FOR ALL TRENCHLESS INSTALLATION.  
 PROP. 160' OF 6" WATER LINE.

THE MATERIAL USED FOR TRENCHLESS INSTALLATION PIPE INSIDE DIMENSION SHALL BE EQUIVALENT TO 6" INSIDE DIAMETER.

NOTE: MAXIMUM ELEVATION AT TOP OF PIPE UNDER CREEK IS 204'.

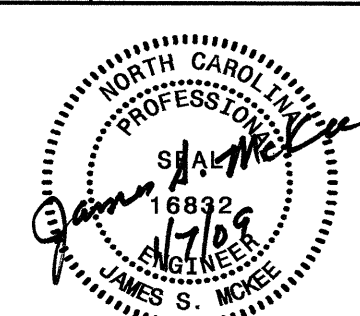

**UTILITY CONSTRUCTION**

MAXIMUM TRENCH WIDTH AT TOP OF PIPE			
NOMINAL PIPE SIZE (INCHES)	TRENCH WIDTH (INCHES)	NOMINAL PIPE SIZE (INCHES)	TRENCH WIDTH (INCHES)
4	28	20	44
6	30	24	48
8	32	30	54
10	34	36	60
12	36	42	66
14	38	48	72
16	40	54	78
18	42		

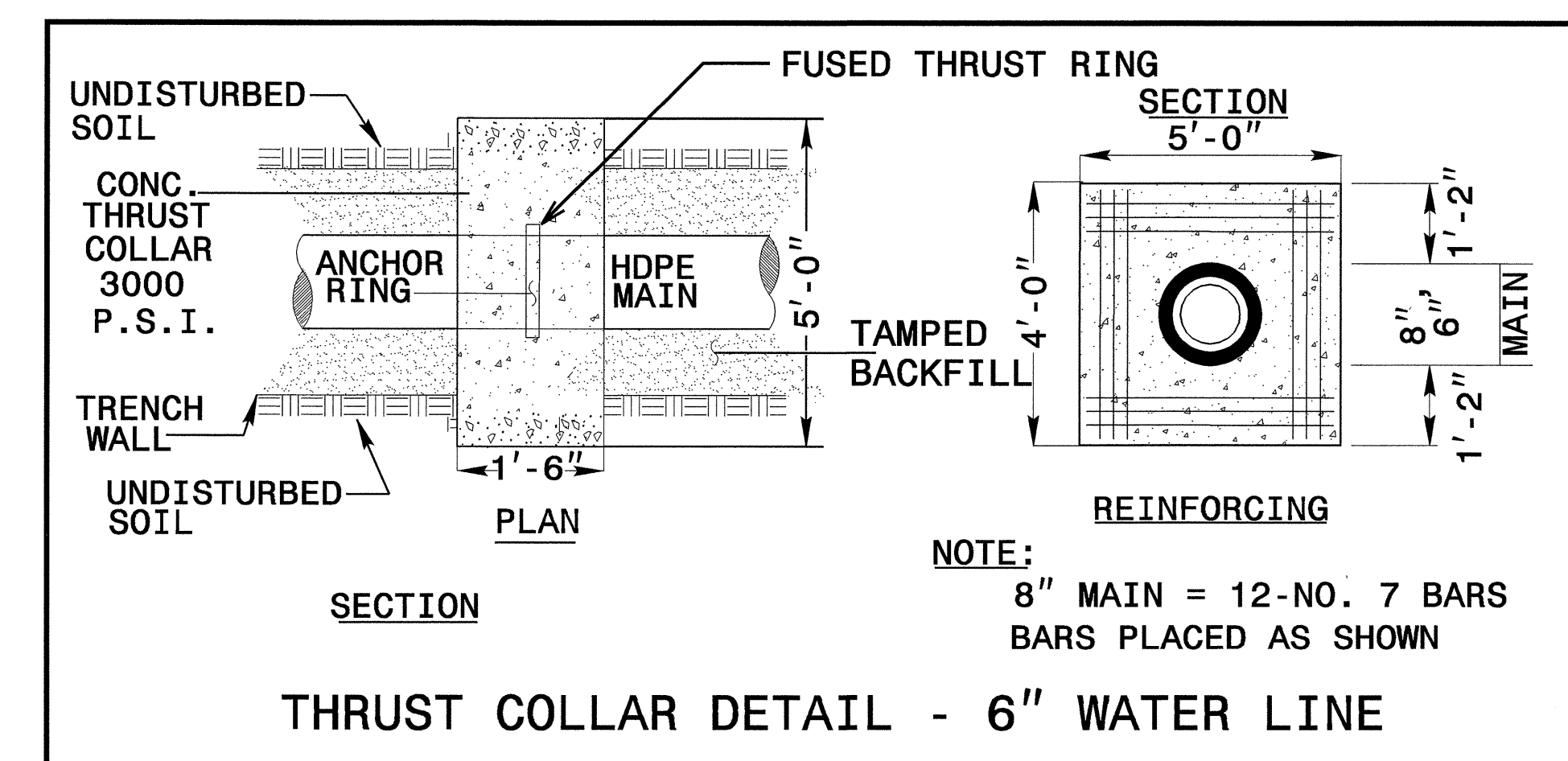
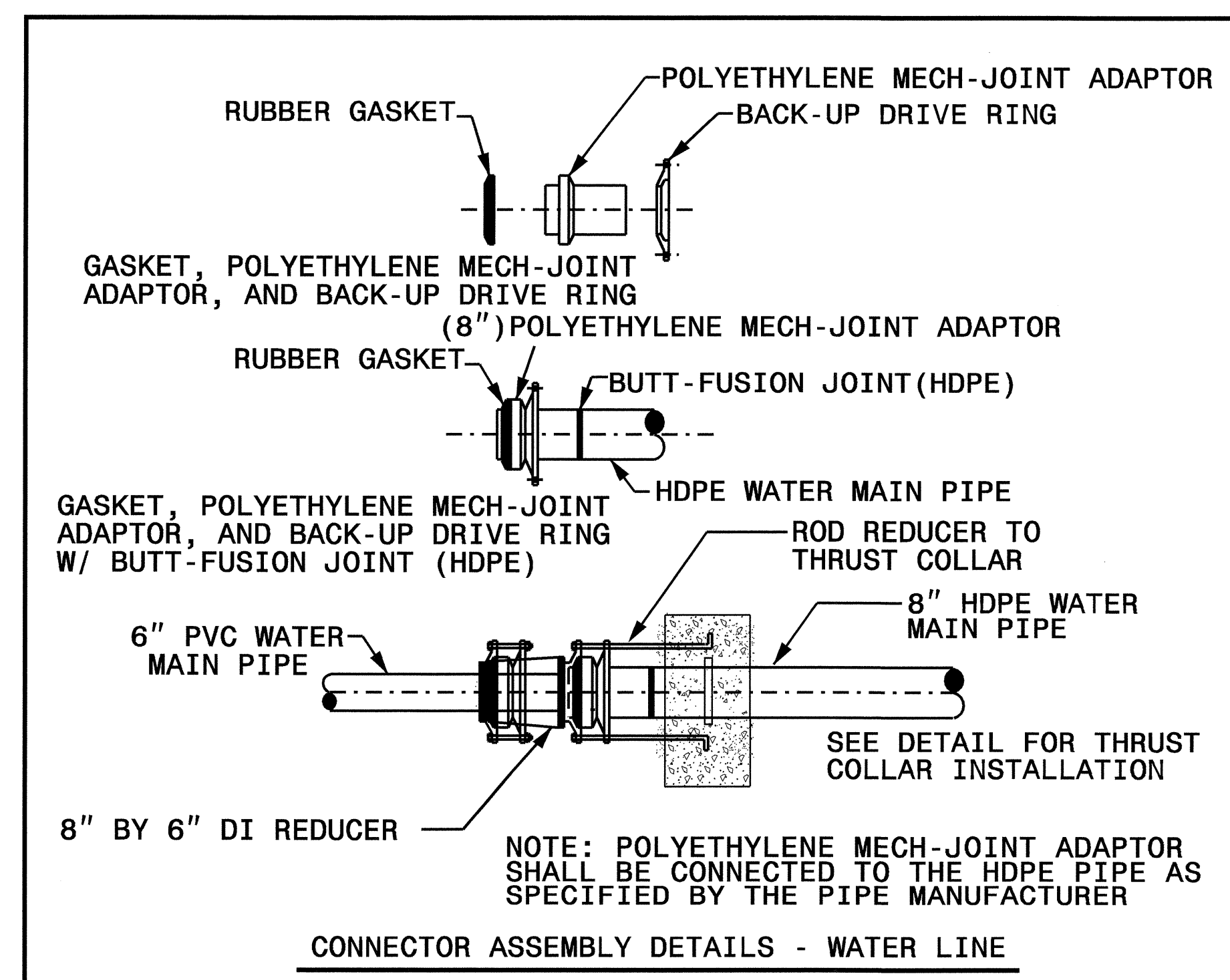
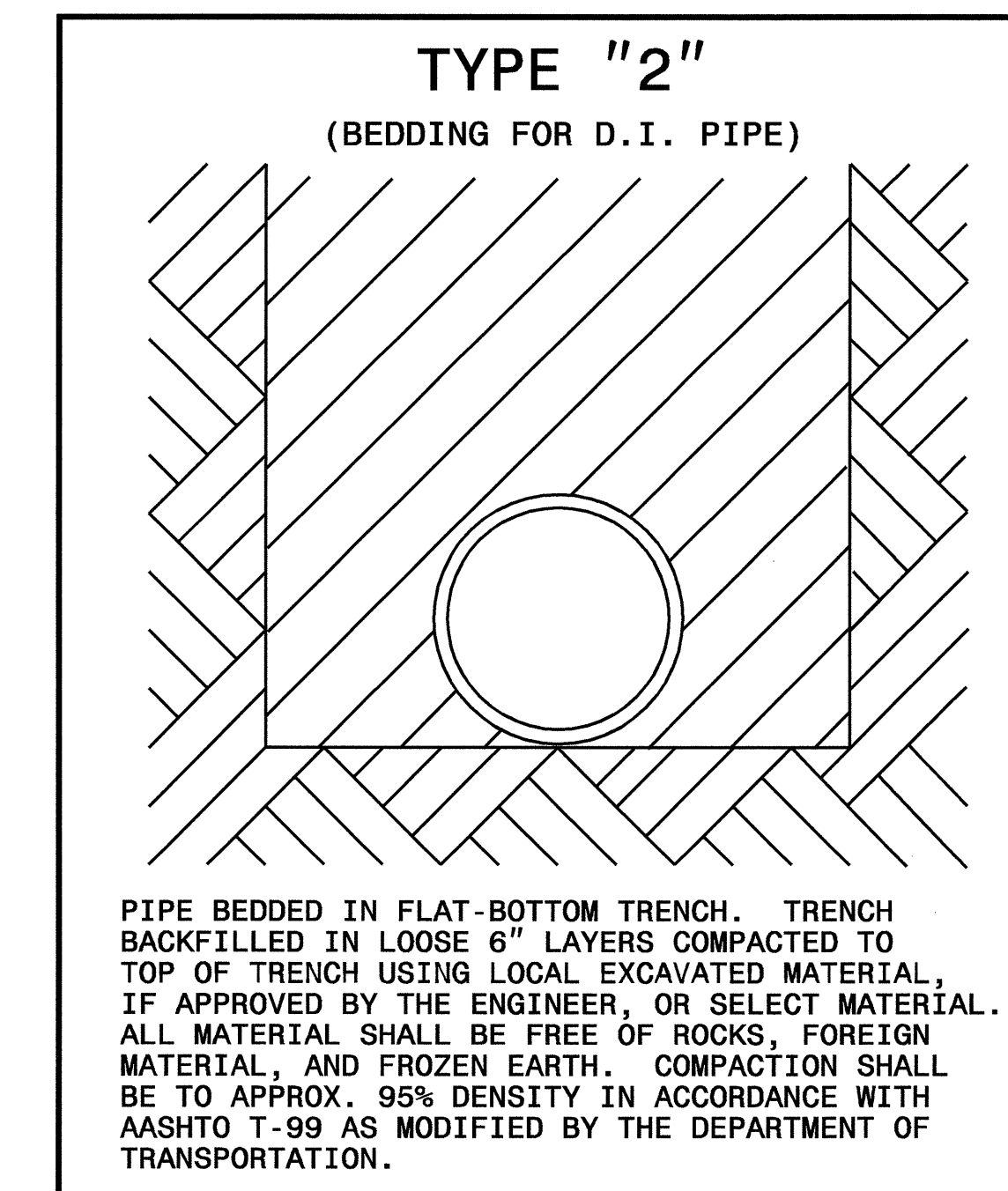
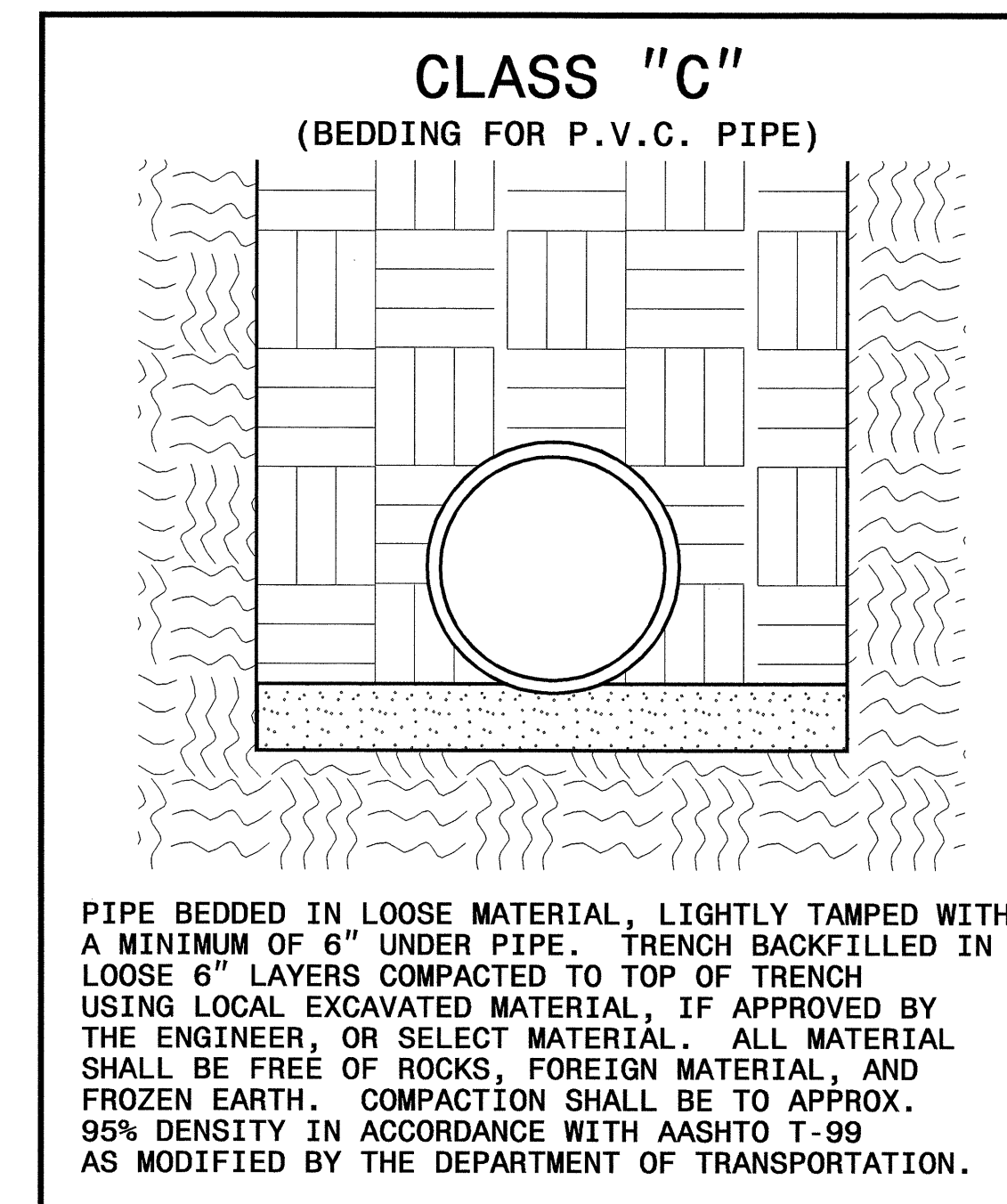

TIP PROJECT: B-3921

CONTRACT: C202123

STATE OF NORTH CAROLINA  
DIVISION OF HIGHWAYS

T.I.P. NO.	SHEET NO.
B-3921	UO-1

**UTILITIES BY OTHERS PLANS  
WARREN COUNTY**

**LOCATION: BRIDGE NO. 45 OVER FISHING CREEK AND APPROACHES  
ON SR 1600 (BALTIMORE ROAD)  
TYPE OF WORK: UTILITIES RELOCATION**

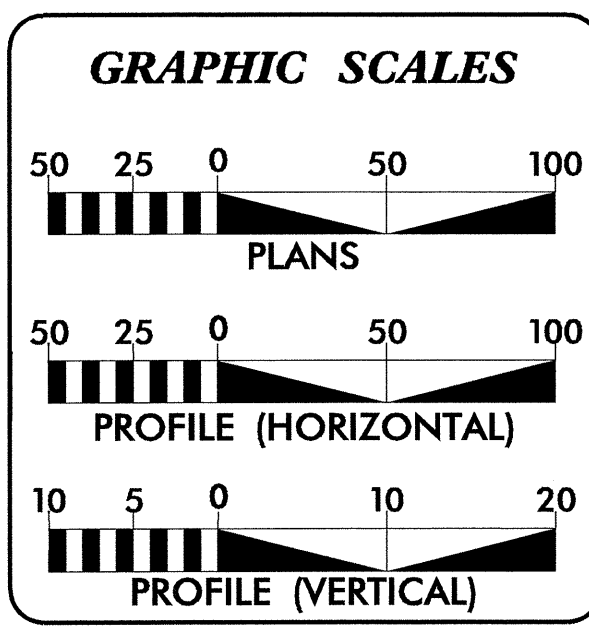
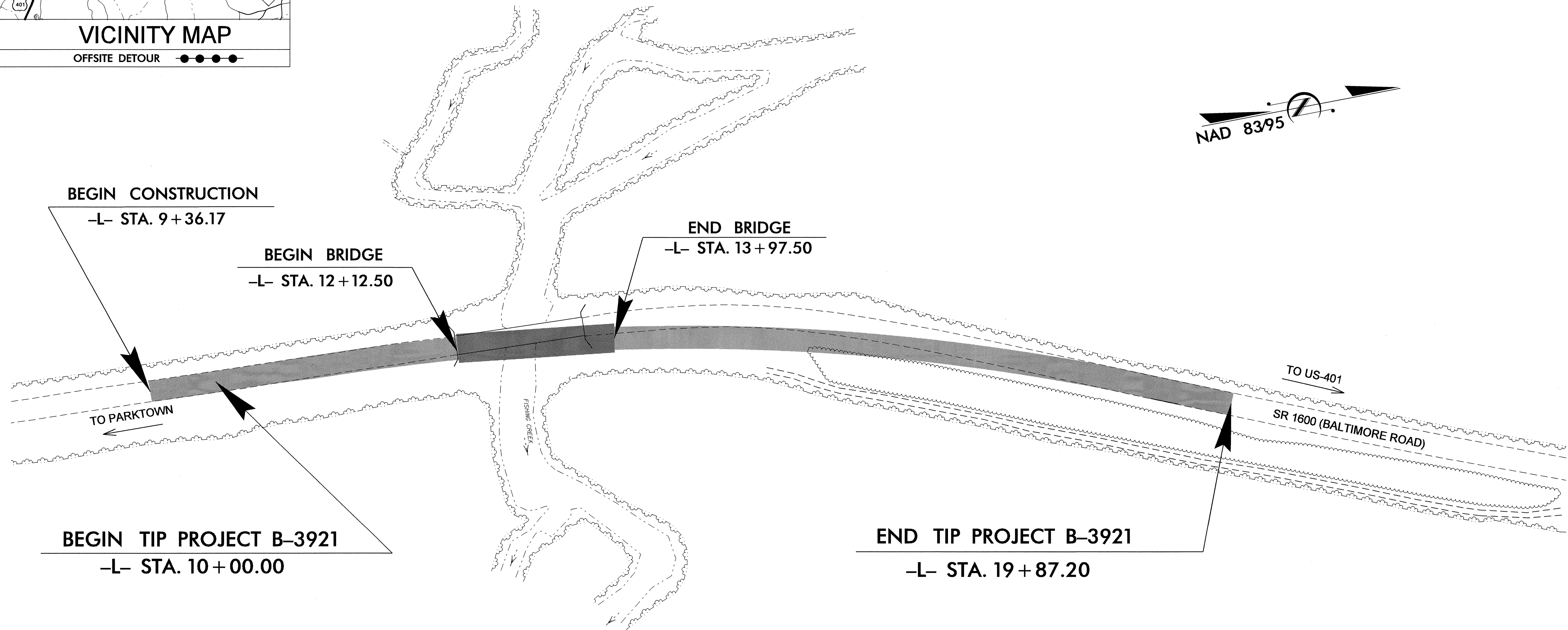
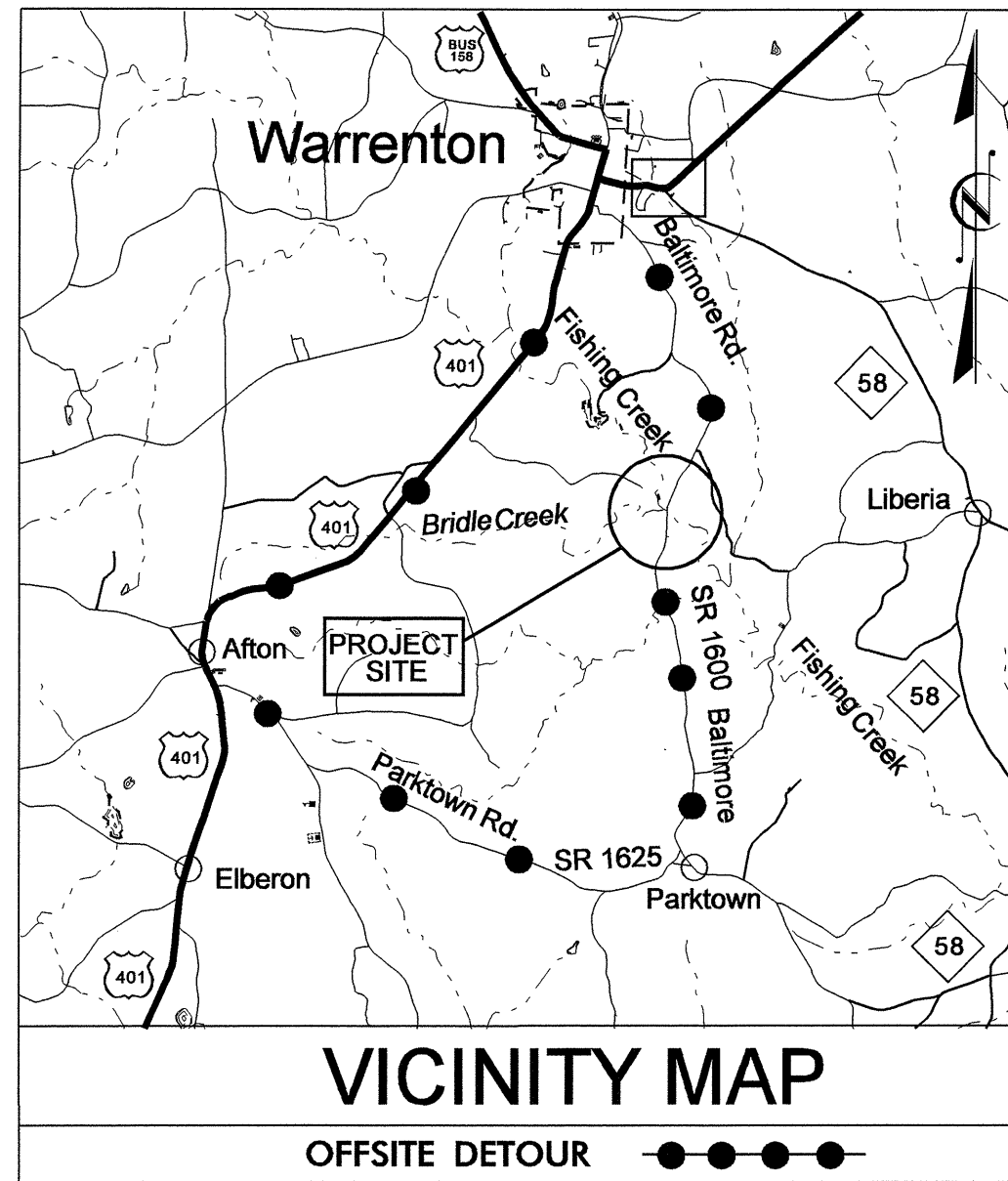

**INDEX OF SHEETS**

SHEET NO.	DESCRIPTION
UO-1	TITLE SHEET
UO-2	UTILITIES BY OTHERS PLAN SHEET

**UTILITY OWNERS ON PROJECT**

- HALIFAX ELECTRIC MEMBERSHIP CORPORATION - POWER
- EMBARQ - TELEPHONE



PREPARED IN THE OFFICE OF:  
**DIVISION OF HIGHWAYS  
UTILITIES ENGINEERING SECTION**

1591 MAIL SERVICES CENTER  
RALEIGH NC 27699-1591  
PHONE (919) 250-4128  
FAX (919) 250-4119

**Roger Worthington, P.E.** UTILITIES SECTION ENGINEER  
**Steve McKee, P.E.** UTILITIES SQUAD LEADER PROJECT ENGINEER  
**Donald Proper** UTILITIES PROJECT DESIGNER

UTILITIES BY OTHERS

NOTE:  
ALL PROPOSED UTILITY WORK SHOWN ON THIS SHEET WILL BE DONE BY OTHERS

NOTE:  
PROP. EMBARQ U/G TELEPHONE CABLES AND FO TELEPHONE CABLES SHALL BE INSTALLED UNDER CREEK BY METHOD OF TRENCHLESS INSTALLATION.

