

WAKE COUNTY

PROJECT REFERENCE NO.	SHEET NO.
I-5114 45052.3.ST1	1

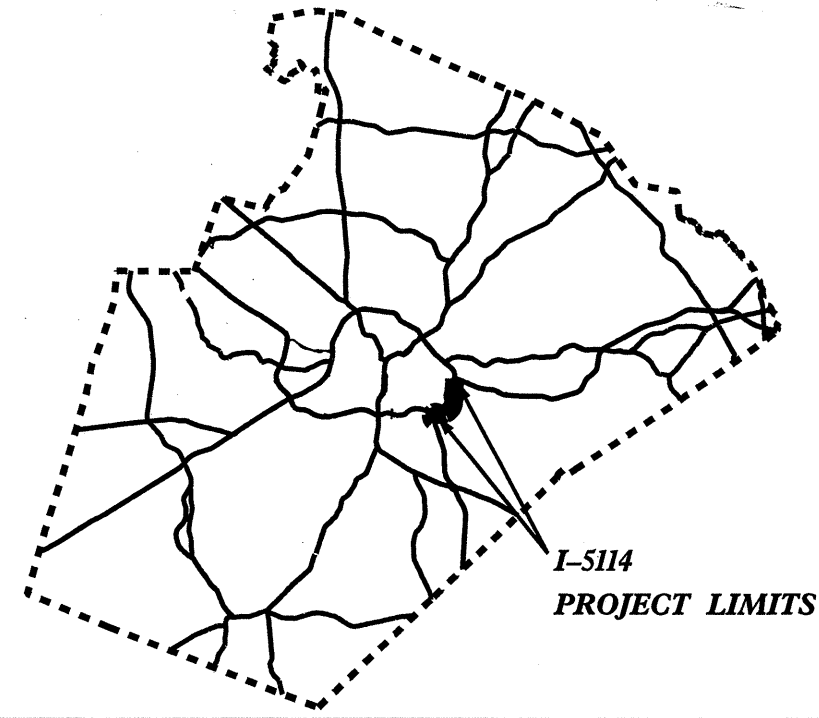

VICINITY MAP

BEGIN PROJECT I-5114

END PROJECT I-5114

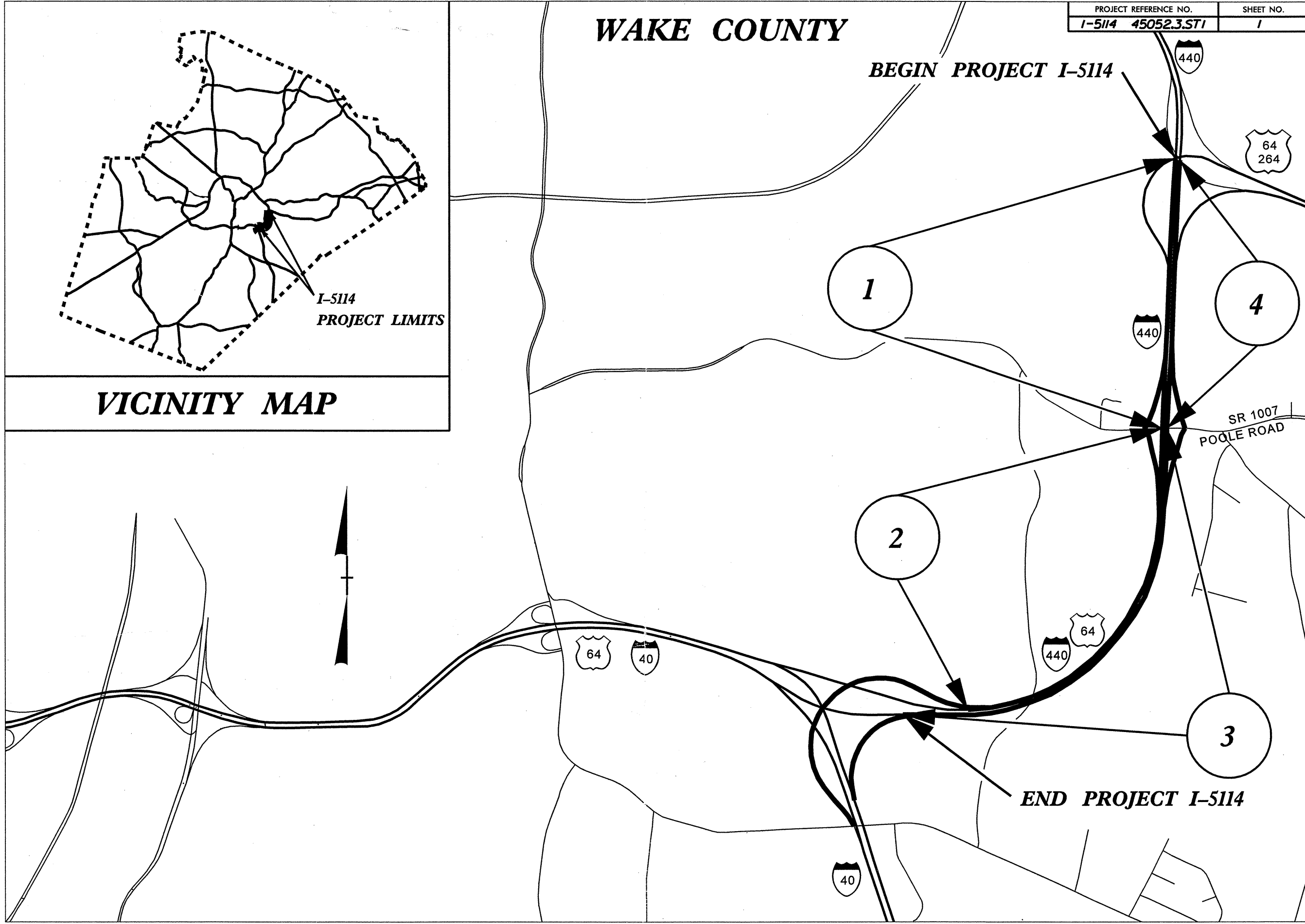

PAVEMENT SCHEDULE	
B	5/8" ULTRA-THIN HOT-MIX ASPHALT, TYPE B
C1	3" ASPHALT CONCRETE SURFACE COURSE, TYPE S9.5C, AT AN AVERAGE RATE OF 168 LBS. PER SQ. YD. IN EACH OF TWO LAYERS
C2	1 1/2" ASPHALT CONCRETE SURFACE COURSE, TYPE S9.5C, AT AN AVERAGE RATE OF 168 LBS. PER SQ. YD.
D	2 1/2" ASPHALT CONCRETE INTERMEDIATE COURSE, TYPE I19.0C, AT AN AVERAGE RATE OF 285 LBS. PER SQ. YD.
U	EXISTING PAVEMENT
V1	PROP. 3" MILLING TO REMOVE EXISTING 3" BONDED CONCRETE OVERLAY
V2	PROP. 4" MILLING TO REMOVE EXISTING 4" BONDED CONCRETE OVERLAY
V3	PROP. CONTINUOUS MILLED RUMBLE STRIP
S	SPOT SHOULDER RECONSTRUCTION BY CONTRACTOR, AS DIRECTED BY THE ENGINEER
Y	SEAL EXISTING PAVEMENT CRACKS AND JOINTS

PROJ. REFERENCE NO.	SHEET NO.	TOTAL SHEETS
I-5114	2	
STATE PROJ. NO.	F.A. PROJ. NO.	DESCRIPTION
45052.3.ST I	STM-0440(6)	

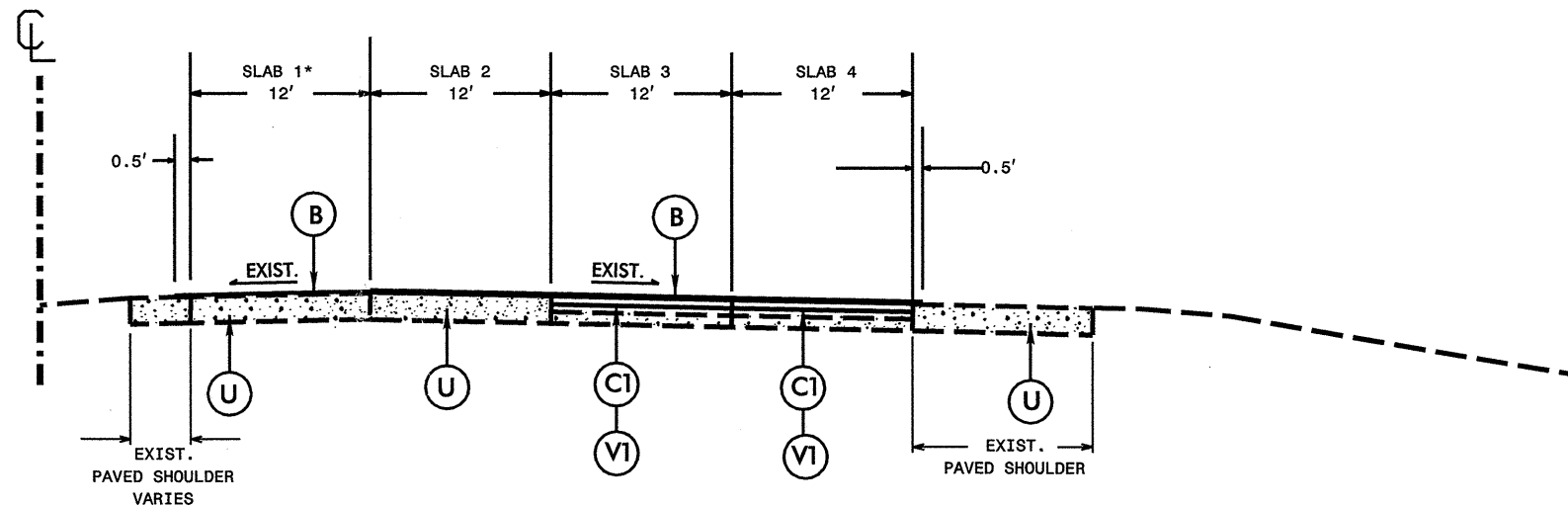

TYPICAL SECTION NO. 1

PLEASE NOTE THAT THE LANES MAY TRANSITION ACROSS THE SLABS

* SLAB 1 NOT CONTINUOUS THROUGH MAP

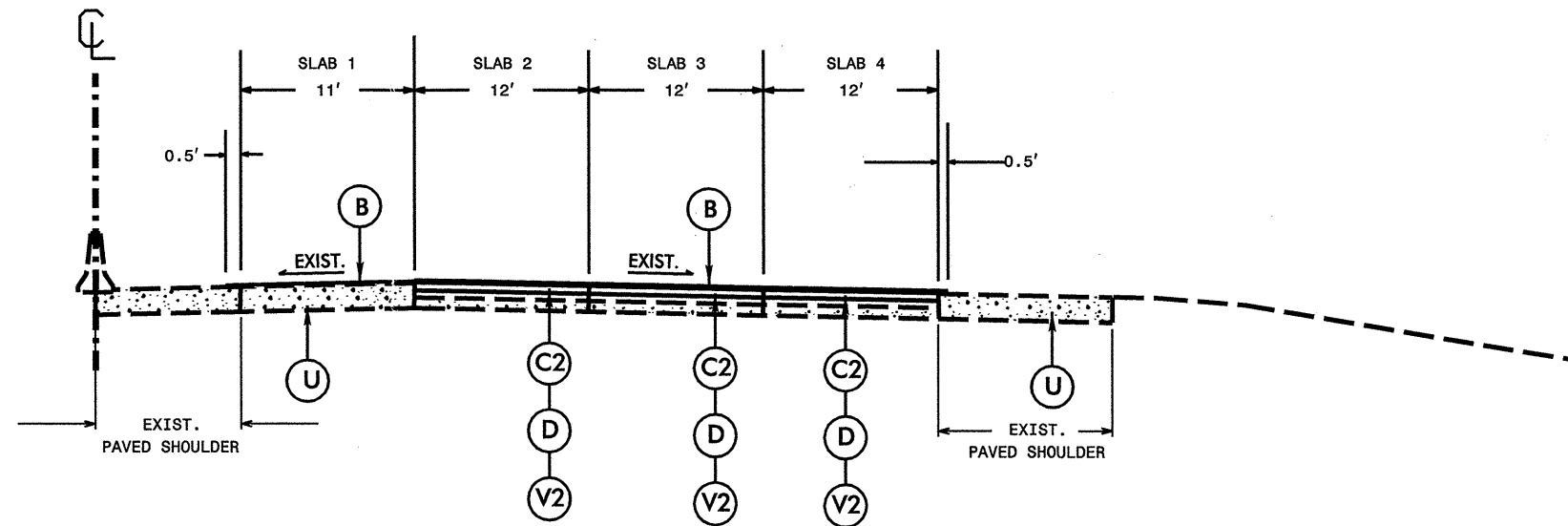

TYPICAL SECTION NO. 2

PLEASE NOTE THAT THE LANES MAY TRANSITION ACROSS THE SLABS

PROJ. REFERENCE NO.	SHEET NO.	TOTAL SHEETS
I-5114	3	
STATE PROJ. NO.	F.A. PROJ. NO.	DESCRIPTION
45052.3.ST I	STM-0440(6)	

PAVEMENT SCHEDULE	
B	5/8" ULTRA-THIN HOT-MIX ASPHALT, TYPE B
C1	3" ASPHALT CONCRETE SURFACE COURSE, TYPE S9.5C, AT AN AVERAGE RATE OF 168 LBS. PER SQ. YD. IN EACH OF TWO LAYERS
C2	1 1/2" ASPHALT CONCRETE SURFACE COURSE, TYPE S9.5C, AT AN AVERAGE RATE OF 168 LBS. PER SQ. YD.
D	2 1/2" ASPHALT CONCRETE INTERMEDIATE COURSE, TYPE I19.0C, AT AN AVERAGE RATE OF 285 LBS. PER SQ. YD.
U	EXISTING PAVEMENT
V1	PROP. 3" MILLING TO REMOVE EXISTING 3" BONDED CONCRETE OVERLAY
V2	PROP. 4" MILLING TO REMOVE EXISTING 4" BONDED CONCRETE OVERLAY
V3	PROP. CONTINUOUS MILLED RUMBLE STRIP
S	SPOT SHOULDER RECONSTRUCTION BY CONTRACTOR, AS DIRECTED BY THE ENGINEER
Y	SEAL EXISTING PAVEMENT CRACKS AND JOINTS

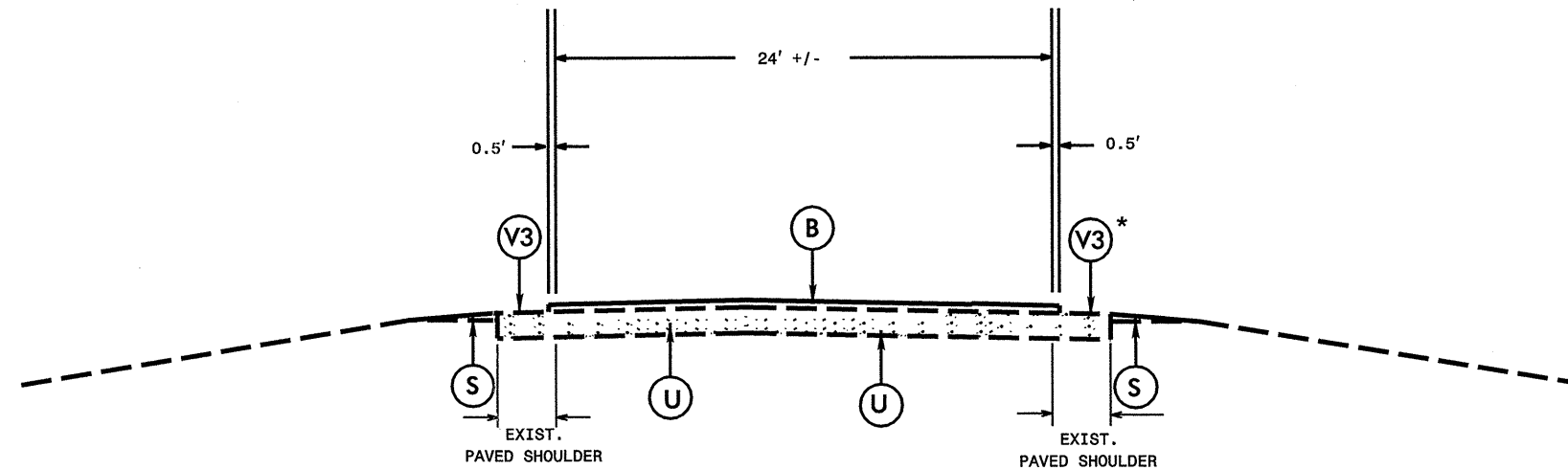

TYPICAL SECTION NO. 3

I-40 RAMP DETAIL

LIMITS OF RAMP WORK TO BE DETERMINED BY ENGINEER

* CONTINUOUS MILLED RUMBLE STRIPS ARE ALREADY IN PLACE IN SOME LOCATIONS

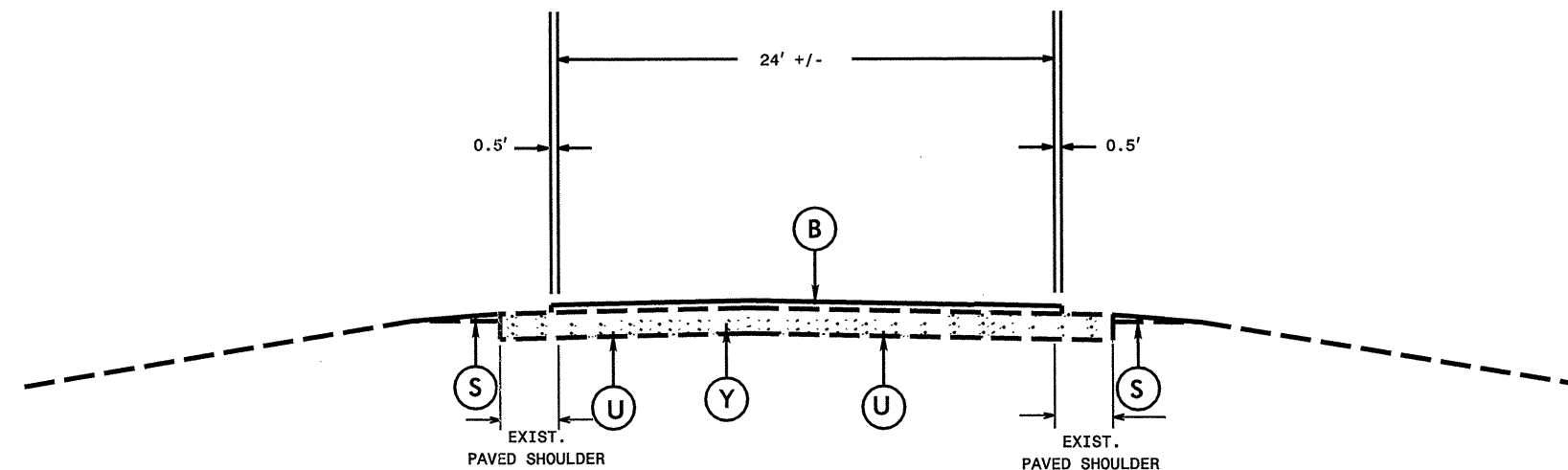

TYPICAL SECTION NO. 4

POOLE ROAD RAMP DETAIL

LIMITS OF RAMP WORK TO BE DETERMINED BY ENGINEER

PROJ. REFERENCE NO.	SHEET NO.	TOTAL SHEETS
I-5114	4	
STATE PROJ. NO.	F.A. PROJ. NO.	DESCRIPTION
45052.3.ST 1	STM-0440(6)	

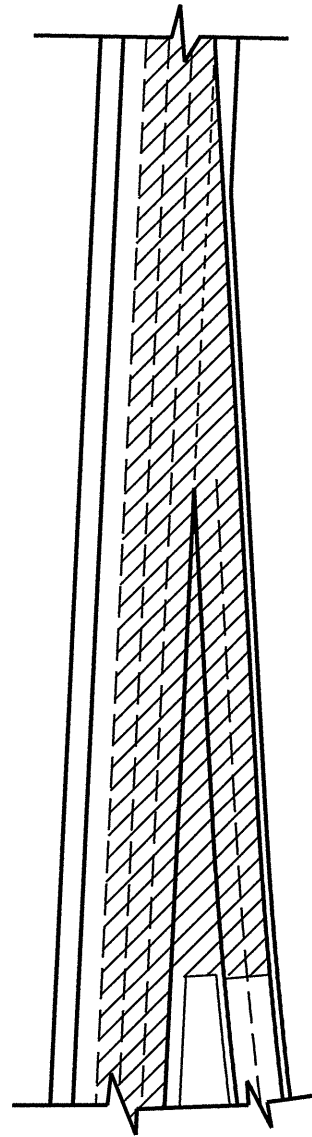

TYPICAL DETAIL OF BONDED OVERLAY
REMOVAL AT GORE AREA

LIMITS OF BONDED OVERLAY REMOVAL
WILL VARY AT EACH INTERCHANGE

USE AT I-40 AND POOLE ROAD INTERCHANGES
LANE 2 BONDED OVERLAY REMOVAL PER TYPICAL

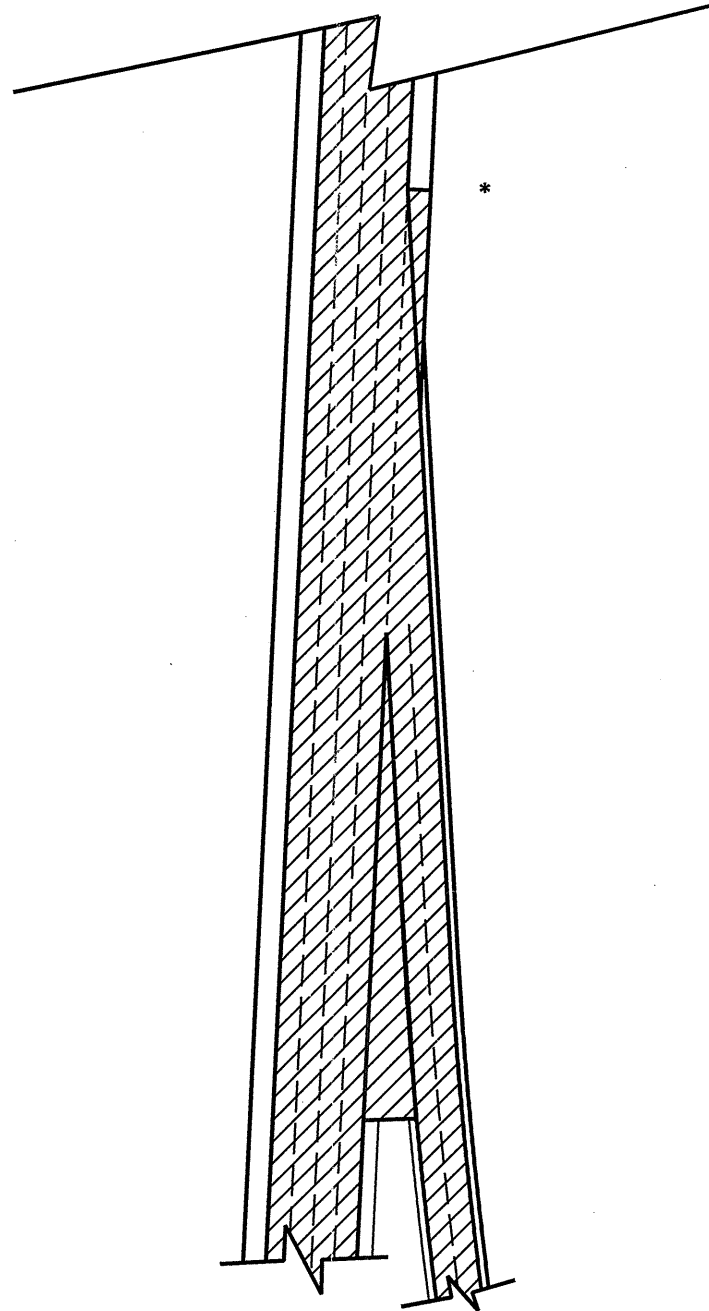

DETAIL OF ULTRATHIN OVERLAY
PLACEMENT AT ACCELERATION
AND DECELERATION LANES

* SQUARED OFF JOINTS AT END OF TAPER ARE ACCEPTABLE

PROJECT NO.	SHEET NO.	TOTAL NO.
I-5114 - 45052.3.ST1	5	

SUMMARY OF QUANTITIES

PROJECT NO	COUNTY	MAP NO	ROUTE	DESCRIPTION	TYP NO	LENGTH MI	WIDTH FT	SEALING EXIST. PVMT. CRACKS LB	SHOULDER RECONSTRUCTION SMI	3" MILLING SY	4" MILLING SY	MILLED RUMBLE STRIPS LF	INTER-MEDIATE COURSE, 119.0C TONS	SURFACE COURSE, S9.5C TONS	PG 64-22 PLANT MIX TONS	PG 70-22 PLANT MIX TONS	PG 70-28 PLANT MIX TONS	ULTRATHIN HOT MIX, TYPE B TONS	APPLICATION OF ULTRATHIN HOT MIX SY	PORTABLE LIGHTING LS	INDUCTIVE LOOP LF	POLICE HR	SEEDING AND MULCHING AC
45052.3.ST1	Wake	1	I-440 INNER AND RAMP	FROM BRIDGE OVER CRABTREE CREEK TO JOINT AT POOLE RD	1, 4	1.05	37	45,000	0.4	15,850				2,663		160	62	1,188	22,792	*	450	2,000	0.3
		2	I-440 INNER AND RAMPS	FROM JOINT AT POOLE ROAD TO JOINT AT I-40 SPLIT	2, 3, 4	1.40	48	15,000	1.4		31,832	5,600	4,536	2,674	213	160	107	2,050	39,424	*			1.0
		3	I-440 OUTER AND RAMPS	FROM JOINT AT I-40 SPLIT TO JOINT AT POOLE ROAD	2, 3, 4	1.50	48	15,000	1.1		36,847	4,224	5,251	3,095	247	186	95	1,822	42,240	*			0.8
		4	I-440 OUTER AND RAMP	FROM JOINT AT POOLE RD TO BRIDGE OVER CRABTREE CREEK	1, 4	1.05	37		0.4	14,784				2,484		149	59	1,144	22,792	*	450		0.3
TOTAL FOR PROJ NO. 45052.3.ST1						5		75,000	3.3	30,634	68,679	9,824	9,787	10,916	460	655	323	6,204	127,248	1	900	2,000	2.4
GRAND TOTAL						5		75,000	3.3	30,634	68,679	9,824	9,787	10,916	460	655	323	6,204	127,248	1	900	2,000	2.4

THERMOPLASTIC AND PAINT QUANTITIES

PROJECT NO	COUNTY	MAP NO	ROUTE	DESCRIPTION	4400000000-E	4405000000-E	4410000000-E	4415000000-E	4420000000-N	4422000000-N	4430000000-E	4445000000-E	4480000000-N	4688000000-E					4721000000-E				
					STATIONARY WORK ZONE SIGN SF	PORTABLE WORK ZONE SIGN SF	BARRICADE MOUNTED WORK ZONE SIGN SF	FLASHING ARROW PANELS, TYPE C EA	CHANGABLE MESSAGE SIGNS EA	CHANGEABLE MESSAGE SIGNS (SHORT TERM) DAY	DRUMS EA	TYPE III BARRICADE LF	TMIA EA	6" X 90 M WHITE THERMO LF	6" X 90 M YELLOW THERMO LF	6" X 120 M WHITE THERMO LF	8" X 90 M WHITE THERMO LF	12" X 90 M WHITE THERMO LF	THERMO MSG ONLY 120 M EA	THERMO MSG I-40 120 M EA	THERMO MSG EAST EA	THERMO MSG THIS 120 M EA	THERMO MSG LANE 120 M EA
45052.3.ST1	Wake	1	I-440 INNER AND RAMP	FROM BRIDGE OVER CRABTREE CREEK TO JOINT AT POOLE RD	375	407	15	3	6	14	410	40	4	6,469	6,469	4,430		1,465	4				
		2	I-440 INNER AND RAMPS	FROM JOINT AT POOLE ROAD TO JOINT AT I-40 SPLIT										13,372	13,372	7,175		1,700	8	8	8	8	
		3	I-440 OUTER AND RAMPS	FROM JOINT AT I-40 SPLIT TO JOINT AT POOLE ROAD										10,330	10,330	6,706	300	3,610					
		4	I-440 OUTER AND RAMP	FROM JOINT AT POOLE RD TO BRIDGE OVER CRABTREE CREEK										6,499	6,499	4,065		1,175	16				
TOTAL FOR PROJ NO. 45052.3.ST1					375	407	15	3	6	14	410	40	4	36,670	36,670	22,376	300	7,950	28	8	8	8	8
GRAND TOTAL					375	407	15	3	6	14	410	40	4	36,670	36,670	22,376	300	7,950	28	8	8	8	8

PROJECT NO	COUNTY	MAP NO	ROUTE	DESCRIPTION	4725000000-E				4775000000-E		4815000000-E	4825000000-E	4840000000-N					4850000000-N		4905000000-N		
					THERMO LT ARROW 90 M EA	THERMO RT ARROW 90 M EA	THERMO STR & RT ARROW 90 M EA	THERMO STR ARROW 90 M EA	6" WHITE COLD APPLIED PLASTIC, TYPE III LF	6" YELLOW COLD APPLIED PLASTIC, TYPE III LF	6" WHITE PAINT LF	12" WHITE PAINT LF	PAINT MSG EAST EA	PAINT MSG I-40 EA	PAINT MSG THIS EA	PAINT MSG LANE EA	PAINT MSG ONLY EA	PAINT STR & RT ARROW EA	PAINT STR ARROW EA	PAINT RT ARROW EA	6" LINE REMOVAL LF	SNOW PLOWABLE MARKERS EA
45052.3.ST1	Wake	1	I-440 INNER AND RAMP	FROM BRIDGE OVER CRABTREE CREEK TO JOINT AT POOLE RD	4	2	2				8,316	1,465					4	2			272	
		2	I-440 INNER AND RAMPS	FROM JOINT AT POOLE ROAD TO JOINT AT I-40 SPLIT		5	5	13	808	560	12,936	1,700	8	8	8	8	8	5	5	5	1,368	468
		3	I-440 OUTER AND RAMPS	FROM JOINT AT I-40 SPLIT TO JOINT AT POOLE ROAD	4				438	250	13,860	3,610									688	525
		4	I-440 OUTER AND RAMP	FROM JOINT AT POOLE RD TO BRIDGE OVER CRABTREE CREEK		8					8,316	588										262
TOTAL FOR PROJ NO. 45052.3.ST1					8	15	7	13	1,246	810	43,428	7,363	8	8	8	8	12	7	5	5	2,056	1,527
GRAND TOTAL					8	15	7	13	1,246	810	43,428	7,363	8	8	8	8	12	7	5	5	2,056	1,527

STATE OF NORTH CAROLINA
DIVISION OF HIGHWAYS

STATE PROJECT REFERENCE NO.	SHEET NO.
I-5114	TCP-1

**PLAN FOR PROPOSED
TRAFFIC CONTROL, MARKING & DELINEATION
WAKE COUNTY**

I-5114

ROADWAY STANDARD DRAWINGS

THE FOLLOWING ROADWAY STANDARDS AS APPEAR IN "ROADWAY STANDARD DRAWINGS" HIGHWAY DESIGN BRANCH - N. C. DEPARTMENT OF TRANSPORTATION - RALEIGH, N. C., DATED JULY 2006 ARE APPLICABLE TO THIS PROJECT AND BY REFERENCE HEREBY ARE CONSIDERED A PART OF THESE PLANS:

STD. NO.	TITLE
1101.02	TEMPORARY LANE CLOSURES
1101.03	TEMPORARY ROAD CLOSURES
1101.04	TEMPORARY SHOULDER CLOSURES
1101.05	WORK ZONE VEHICLE ACCESSES
1101.11	TRAFFIC CONTROL DESIGN TABLES
1110.01	STATIONARY WORK ZONE SIGNS
1110.02	PORTABLE WORK ZONE SIGNS
1115.01	FLASHING ARROW PANELS
1130.01	DRUMS
1145.01	BARRICADES
1165.01	TRUCK MOUNTED IMPACT ATTENUATOR
1205.01	PAVEMENT MARKINGS - LINE TYPES & OFFSETS
1205.02	PAVEMENT MARKINGS - 2 LANE & MULTILANE ROADWAYS
1205.03	PAVEMENT MARKINGS - INTERCHANGES
1205.06	PAVEMENT MARKINGS - THRU LANE DROPS
1205.08	PAVEMENT MARKINGS - SYMBOLS & WORD MESSAGES
1205.12	PAVEMENT MARKINGS - BRIDGES
1250.01	PAVEMENT MARKER SPACING
1253.01	SNOWFLOWABLE RAISED PAVEMENT MARKERS

INDEX OF SHEETS

SHEET NO.	TITLE
TCP-1	LIST OF APPLICABLE ROADWAY STANDARD DRAWINGS, LEGEND AND INDEX OF SHEETS
TCP-2	PROJECT NOTES
TCP-3	PROJECT OVERVIEW
TCP-4 & 4A	PHASING
TCP-5 THRU 15	OUTER I-440 DETAILS
TCP-16 THRU 27	INNER I-440 DETAILS
TCP-28	I-40 RAMP DETOURS
TCP-29	POOLE RD. RAMP DETOURS (NORTH SIDE)
TCP-30	POOLE RD. RAMP DETOURS (SOUTH SIDE)
TCP-31	ADVANCED WORK ZONE WARNING SIGNS FOR FREEWAYS (4 LANES OR GREATER)
TCP-32	INTERSTATE DUAL/TRIPLE LANE CLOSURES
TCP-33	ADVANCED WORK ZONE WARNING SIGN DESIGN

LEGEND

- GENERAL**
- DIRECTION OF TRAFFIC FLOW
 - NORTH ARROW
 - PROPOSED PVMT. EXIST. PVMT.
 - WORK AREA
 - REMOVAL OF EXISTING PAVEMENT
- TRAFFIC CONTROL DEVICES**
- TYPE I BARRICADE
 - TYPE II BARRICADE
 - TYPE III BARRICADE
 - CONE
 - DRUM SKINNY DRUM
 - FLASHING ARROW PANEL (TYPE C)
 - STATIONARY SIGN
 - PORTABLE SIGN
 - STATIONARY OR PORTABLE SIGN
 - CRASH CUSHION
 - CHANGEABLE MESSAGE SIGN
 - TRUCK MOUNTED IMPACT ATTENUATOR (TMIA)
 - POLICE
 - FLAGGER
- PAVEMENT MARKINGS**
- CRYSTAL/CRYSTAL PAVEMENT MARKER
 - YELLOW/YELLOW PAVEMENT MARKER
 - CRYSTAL/RED PAVEMENT MARKER
 - PAVEMENT MARKING SYMBOLS

TIP PROJECT:

PLAN REVIEWED BY: WORK ZONE TRAFFIC CONTROL UNIT	APPROVED: <i>Michael J Rzepka</i> DATE: 3-25-09	PLAN PREPARED FOR N.C.D.O.T. BY:	
J. S. BOURNE, P.E. _____ TRAFFIC CONTROL ENGINEER	SEAL 	M. T. RZEPKA, P.E. _____ PROJECT ENGINEER	
J. ISMAK, P.E. _____ TRAFFIC CONTROL PROJECT ENGINEER		G. E. PARKER _____ DESIGN ENGINEER	
J. PORTANOVA, P.E. _____ TRAFFIC CONTROL PROJ. DESIGN ENGINEER		B. L. MARIOTTE _____ DESIGN TECHNICIAN	
_____ TRAFFIC CONTROL DESIGN ENGINEER			
_____ TRAFFIC CONTROL DESIGN TECHNICIAN			

GENERAL NOTES

CHANGES MAY BE REQUIRED WHEN PHYSICAL DIMENSIONS IN THE DETAIL DRAWINGS, STANDARD DETAILS AND ROADWAY DETAILS ARE NOT ATTAINABLE TO MEET FIELD CONDITIONS, OR RESULT IN DUPLICATE, OR UNDESIRABLE OVERLAPPING OF DEVICES. MODIFICATION MAY INCLUDE: MOVING, SUPPLEMENTING, COVERING OR REMOVAL OF DEVICES, AS DIRECTED BY THE ENGINEER.

THE FOLLOWING GENERAL NOTES APPLY AT ALL TIMES FOR THE DURATION OF THE CONSTRUCTION PROJECT, EXCEPT WHEN OTHERWISE NOTED IN THE PLAN, OR DIRECTED BY THE ENGINEER.

TIME RESTRICTIONS

A) DO NOT CLOSE OR NARROW TRAVEL LANES AS FOLLOWS:

ROAD NAME	DAY AND TIME RESTRICTIONS
I-440 & RAMPS I-40 US 64 BYPASS	MONDAY THRU SUNDAY, 6:00 A.M. TO 9:00 P.M.

B) DO NOT CLOSE OR NARROW TRAVEL LANES DURING HOLIDAYS AND SPECIAL EVENTS AS FOLLOWS:

ROAD NAME
I-440 & RAMPS I-40 US 64 BYPASS

HOLIDAY

- FOR ANY UNEXPECTED OCCURRENCE THAT CREATES UNUSUALLY HIGH TRAFFIC VOLUMES, AS DIRECTED BY THE ENGINEER.
- FOR NEW YEAR'S, BETWEEN THE HOURS OF 9:00 P.M. DECEMBER 31st TO 6:00 A.M. JANUARY 2ND. IF NEW YEAR'S DAY IS ON A FRIDAY, SATURDAY, SUNDAY, OR MONDAY THEN UNTIL 6:00 A.M. THE FOLLOWING TUESDAY.
- FOR EASTER, BETWEEN THE HOURS OF 9:00 P.M. THURSDAY AND 6:00 A.M. MONDAY.
- FOR MEMORIAL DAY, BETWEEN THE HOURS OF 9:00 P.M. FRIDAY TO 6:00 A.M. TUESDAY.
- FOR INDEPENDENCE DAY, BETWEEN THE HOURS OF 9:00 P.M. THE DAY BEFORE INDEPENDENCE DAY AND 6:00 A.M. THE DAY AFTER INDEPENDENCE DAY.

IF INDEPENDENCE DAY IS ON A FRIDAY, SATURDAY, SUNDAY OR MONDAY THEN BETWEEN THE HOURS OF 9:00 P.M. THE THURSDAY BEFORE INDEPENDENCE DAY AND 6:00 A.M. THE TUESDAY AFTER INDEPENDENCE DAY.
- FOR LABOR DAY, BETWEEN THE HOURS OF 9:00 P.M. FRIDAY AND 6:00 A.M. TUESDAY.
- FOR THANKSGIVING DAY, BETWEEN THE HOURS OF 9:00 P.M. TUESDAY TO 6:00 A.M. MONDAY.
- FOR CHRISTMAS, BETWEEN THE HOURS OF 9:00 P.M. THE FRIDAY BEFORE THE WEEK OF CHRISTMAS DAY AND 6:00 A.M. THE FOLLOWING TUESDAY AFTER THE WEEK OF CHRISTMAS.

C) DO NOT CLOSE ROADS AS FOLLOWS:

ROAD NAME	DAY AND TIME RESTRICTIONS
I-40 RAMPS AT I-440 POOLE RD. RAMPS	MONDAY THRU SUNDAY, 5:00 A.M. TO MIDNIGHT

D) DO NOT STOP TRAFFIC AS FOLLOWS:

ROAD NAME	DAY AND TIME RESTRICTIONS	DURATION AND OPERATION
I-440 I-40 US 64 BYPASS & RAMPS	MONDAY THRU SUNDAY, 5:00 A.M. TO MIDNIGHT	30 MINUTES, TRAFFIC OPERATIONS

PROJECT NOTES

LANE AND SHOULDER CLOSURE REQUIREMENTS

- E) REMOVE LANE CLOSURE DEVICES FROM THE LANE WHEN WORK IS NOT BEING PERFORMED BEHIND THE LANE CLOSURE OR WHEN A LANE CLOSURE IS NO LONGER NEEDED, OR AS DIRECTED BY THE ENGINEER.
- F) WHEN PERSONNEL AND/OR EQUIPMENT ARE WORKING WITHIN 15 FT OF AN AN OPEN TRAVEL LANE, CLOSE THE NEAREST OPEN SHOULDER USING ROADWAY STANDARD DRAWING NO. 1101.04 UNLESS THE WORK AREA IS PROTECTED BY BARRIER OR GUARDRAIL OR A LANE CLOSURE IS INSTALLED.
- G) WHEN PERSONNEL AND/OR EQUIPMENT ARE WORKING ON THE SHOULDER ADJACENT TO AN UNDIVIDED FACILITY AND WITHIN 5 FT OF AN OPEN TRAVEL LANE, CLOSE THE NEAREST OPEN TRAVEL LANE USING ROADWAY STANDARD DRAWING NO. 1101.02 UNLESS THE WORK AREA IS PROTECTED BY BARRIER OR GUARDRAIL.
- WHEN PERSONNEL AND/OR EQUIPMENT ARE WORKING ON THE SHOULDER ADJACENT TO A DIVIDED FACILITY AND WITHIN 10 FT OF AN OPEN TRAVEL LANE, CLOSE THE NEAREST OPEN TRAVEL LANE USING ROADWAY STANDARD DRAWING NO. 1101.02 UNLESS THE WORK AREA IS PROTECTED BY BARRIER OR GUARDRAIL.
- H) WHEN PERSONNEL AND/OR EQUIPMENT ARE WORKING WITHIN A LANE OF TRAVEL OF AN UNDIVIDED OR DIVIDED FACILITY, CLOSE THE LANE ACCORDING TO THE TRAFFIC CONTROL PLANS, ROADWAY STANDARD DRAWINGS OR AS DIRECTED BY THE ENGINEER. CONDUCT THE WORK SO THAT ALL PERSONNEL AND/OR EQUIPMENT REMAIN WITHIN THE CLOSED TRAVEL LANE.
- I) DO NOT WORK SIMULTANEOUSLY WITHIN 15 FT ON BOTH SIDES OF AN OPEN TRAVELWAY RAMP OR LOOP WITHIN THE SAME LOCATION UNLESS PROTECTED WITH GUARDRAIL OR BARRIER.
- J) DO NOT INSTALL MORE THAN THREE MILES OF LANE CLOSURE ON I-440 MEASURED FROM THE BEGINNING OF THE MERGE TAPER TO THE END OF THE LANE CLOSURE.
- K) DO NOT INSTALL MORE THAN ONE LANE CLOSURE, IN ANY ONE DIRECTION, ON I-440.

PAVEMENT EDGE DROP OFF REQUIREMENTS

- L) BACKFILL AT A 6:1 SLOPE UP TO THE EDGE AND ELEVATION OF EXISTING PAVEMENT IN AREAS ADJACENT TO AN OPENED TRAVEL LANE THAT HAS AN EDGE OF PAVEMENT DROP-OFF AS FOLLOWS:
- BACKFILL DROP-OFFS THAT EXCEED 2 INCHES ON ROADWAYS WITH POSTED SPEED LIMITS OF 45 MPH OR GREATER.
- BACKFILL DROP-OFFS THAT EXCEED 3 INCHES ON ROADWAYS WITH POSTED SPEED LIMITS LESS THAN 45 MPH.
- BACKFILL WITH SUITABLE COMPACTED MATERIAL, AS APPROVED BY THE ENGINEER, AT NO EXPENSE TO THE DEPARTMENT.
- M) DO NOT EXCEED A DIFFERENCE OF 2 INCHES IN ELEVATION BETWEEN OPEN LANES OF TRAFFIC FOR NOMINAL LIFTS OF 1.5 INCHES. INSTALL ADVANCE WARNING "UNEVEN LANES" SIGNS (W8-11) 1000 FEET IN ADVANCE AND A MINIMUM OF EVERY HALF MILE THROUGHOUT THE UNEVEN AREA.

TRAFFIC PATTERN ALTERATIONS

- N) NOTIFY THE ENGINEER TWENTY ONE (21) CALENDAR DAYS PRIOR TO ANY TRAFFIC PATTERN ALTERATION.

SIGNING

- O) INSTALL ADVANCE WORK ZONE WARNING SIGNS WHEN WORK IS WITHIN 40 FT FROM THE EDGE OF TRAVEL LANE AND NO MORE THAN THREE (3) DAYS PRIOR TO THE BEGINNING OF CONSTRUCTION.
- P) PROVIDE DETOUR SIGNING WITHIN AND OFF THE PROJECT LIMITS.
- Q) COVER OR REMOVE ALL DETOUR SIGNS WITHIN AND OFF THE PROJECT LIMITS WHEN A DETOUR IS NOT IN OPERATION.
- R) ENSURE ALL NECESSARY SIGNING IS IN PLACE PRIOR TO ALTERING ANY TRAFFIC PATTERN.

TRAFFIC CONTROL DEVICES

- S) SPACE CHANNELIZING DEVICES IN WORK AREAS NO GREATER THAN TWICE THE POSTED SPEED LIMIT (MPH), EXCEPT 10 FT ON-CENTER IN RADII, AND 3 FT. OFF THE EDGE OF AN OPEN TRAVELWAY, WHEN LANE CLOSURES ARE NOT IN EFFECT.
- T) PLACE TYPE III BARRICADES, WITH "ROAD CLOSED" SIGN R11-2 ATTACHED, OF SUFFICIENT LENGTH TO CLOSE ENTIRE ROADWAY.
- U) PLACE ADDITIONAL SETS OF THREE CHANNELIZING DEVICES PERPENDICULAR TO THE EDGE OF TRAVELWAY ON 500 FT CENTERS WHEN UNOPENED LANES ARE CLOSED TO TRAFFIC.

PAVEMENT MARKINGS AND MARKERS

- V) INSTALL PAVEMENT MARKINGS AND PAVEMENT MARKERS ON THE FINAL SURFACE AS FOLLOWS:
- | ROAD NAME | MARKING | MARKER |
|---------------|---------------|--------------|
| I-440 & RAMPS | THERMOPLASTIC | SNOWPLOWABLE |
- W) INSTALL TEMPORARY PAVEMENT MARKINGS AND TEMPORARY PAVEMENT MARKERS ON INTERIM LAYERS OF PAVEMENT AS FOLLOWS:
- | ROAD NAME | MARKING | MARKER |
|---------------|---------|--------|
| I-440 & RAMPS | PAINT | |
- X) PLACE ONE APPLICATION OF PAINT FOR TEMPORARY TRAFFIC PATTERNS. PLACE A SECOND APPLICATION OF PAINT SIX (6) MONTHS AFTER THE INITIAL APPLICATION AND EVERY SIX MONTHS AS DIRECTED BY THE ENGINEER.
- Y) TIE PROPOSED PAVEMENT MARKING LINES TO EXISTING PAVEMENT MARKING LINES.
- Z) REMOVE/REPLACE ANY CONFLICTING/DAMAGED PAVEMENT MARKINGS AND MARKERS BY THE END OF EACH DAY'S OPERATION.

MISCELLANEOUS



- AA) POLICE MAY BE USED TO MAINTAIN TRAFFIC THROUGH THE WORK AREA AND/OR INTERSECTIONS, AS DIRECTED BY THE ENGINEER.

LOCAL NOTES

- COORDINATE LANE CLOSURES WITH THE CONTRACTOR ON ANY OTHER PROJECT.
- COORDINATE WITH THE TRAFFIC MANAGEMENT CENTER PRIOR TO INSTALLING ANY LANE CLOSURES.
- PROVIDE A TRAFFIC CONTROL SUPERVISOR TO BE AVAILABLE AT ALL TIMES. SEE SPECIAL PROVISION.
- SPEED DETECTION LOOPS IN EXISTING LOCATIONS ON I-440 SHALL BE REPLACED PRIOR TO PLACING THE FINAL LAYER OF SURFACE COURSE.
- WAIT A MINIMUM OF 30 DAYS AFTER PLACEMENT OF THE FINAL LAYER OF SURFACE COURSE BEFORE INSTALLING THE SNOWPLOWABLE PAVEMENT MARKERS.

KO & ASSOCIATES, P.C.
Consulting Engineers
A Florence & Hutcheson, Inc. Company
5121 KINGDOM WAY, SUITE 100 RALEIGH, N.C. 27607
(919) 851-0066

PROJ. REFERENCE NO.	SHEET NO.
I-5114	TCP-2

APPROVED: <i>Michael E. Rippe</i> DATE: 3-26-09	PROJECT NOTES	
SEAL 	SCALE: NONE	
	DATE: MAR 09	
	DWG. BY: BLM	
	DESIGN BY: GEP	
REVIEWED BY: MTR	REVISIONS	

PROJECT OVERVIEW

KO & ASSOCIATES, P.C.
 Consulting Engineers
 A Florence & Hutcheson, Inc. Company
 5121 KINGDOM WAY, SUITE 100 RALEIGH, N.C. 27607
 (919) 851-6066

PROJ. REFERENCE NO.	SHEET NO.
I-5114	TCP-3

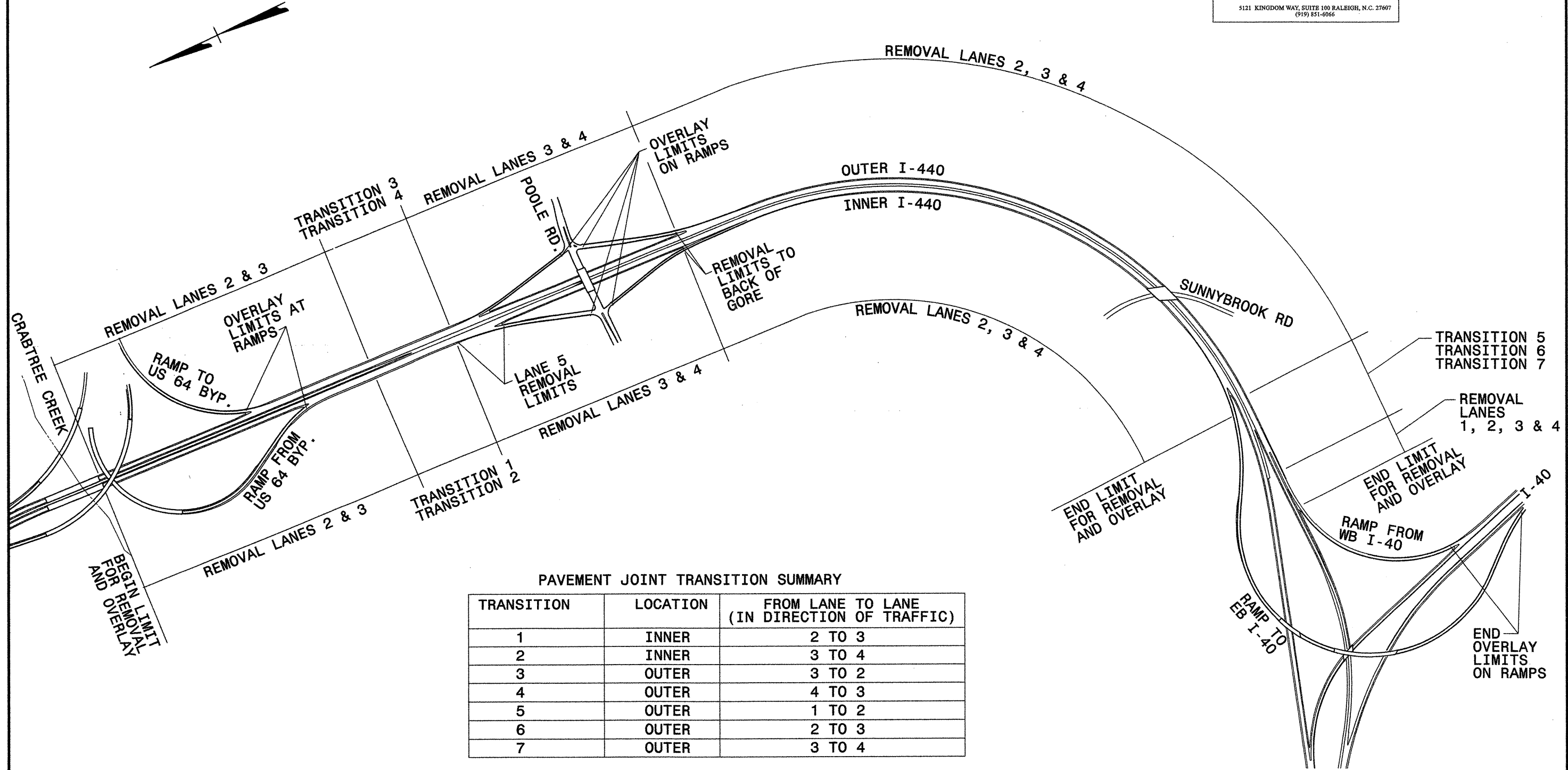

PAVEMENT JOINT TRANSITION SUMMARY

TRANSITION	LOCATION	FROM LANE TO LANE (IN DIRECTION OF TRAFFIC)
1	INNER	2 TO 3
2	INNER	3 TO 4
3	OUTER	3 TO 2
4	OUTER	4 TO 3
5	OUTER	1 TO 2
6	OUTER	2 TO 3
7	OUTER	3 TO 4

SECTION VIEW - LANE ASSIGNMENTS

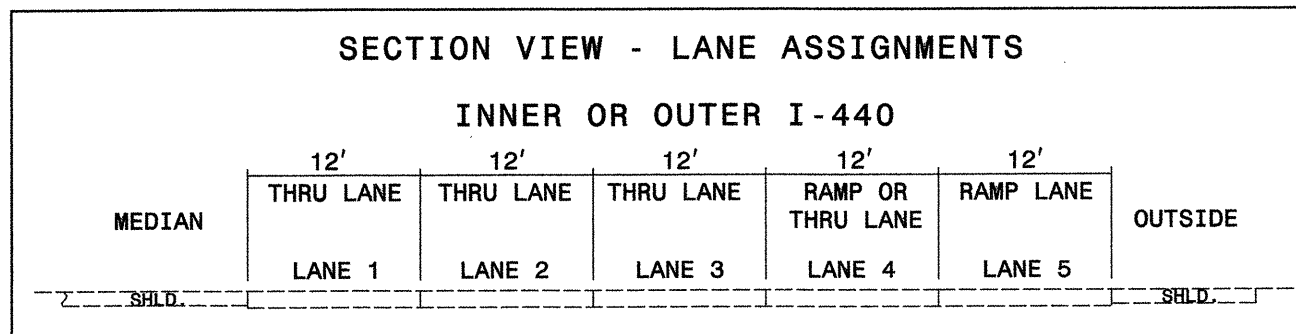

APPROVED: <i>Michael T. Rzepka</i> DATE: 3-25-09	PROJECT OVERVIEW	
	SCALE: NONE	
	DATE: MAR 09	
	DWG. BY: BLM	
	DESIGN BY: GEP	
REVIEWED BY: MTR	REVISIONS	

R:\plans\5114_to_top_overview_sheet.dgn
 3/25/2009 12:42:43 PM

PHASING

KO & ASSOCIATES, P.C.
 Consulting Engineers
 A Florence & Hutcheson, Inc. Company
 5121 KINGDOM WAY, SUITE 100 RALEIGH, N.C. 27607
 (919) 851-6066

PROJ. REFERENCE NO.	SHEET NO.
I-5114	TCP-4

SEE SHEET TCP-3 FOR OVERVIEW OF PAVEMENT REMOVAL AND OVERLAY LIMITS AND TRANSITION AREAS.

LOCAL NOTES 1 THROUGH 3 APPLY AT ALL TIMES DURING CONSTRUCTION OF THE PROJECT.

PHASE II WORK MAY BE COMPLETED SIMULTANEOUSLY WITH PHASE I WORK. WORK IS PHASED IN THE DIRECTION OF TRAFFIC.

PHASE I

PHASE I WORK INVOLVES CONSTRUCTION ON OUTER I-440. AFTER EACH WORK PERIOD, REMOVE LANE AND ROAD CLOSURES, AND REPLACE DAMAGED PAVEMENT MARKINGS.

CONTRACTOR SHALL COMPLETE THE WORK IN PHASE I BY DATE DEFINED IN INTERMEDIATE CONTRACT TIME. SEE INTERMEDIATE CONTRACT TIME AND LIQUIDATED DAMAGES.

STEP 1

INSTALL ALL ADVANCE WARNING SIGNS (SEE SHEET TCP-31) ON BOTH INNER AND OUTER I-440. INSTALL CHANGEABLE MESSAGE SIGNS AS DIRECTED BY THE ENGINEER.

STEPS 2 & 3 ADDRESS LANE 1, TRANSITION 5, AND LANE 2 TO ADJACENT TO POOLE RD. EXIT RAMP GORE.

STEP 2

USING ROADWAY STANDARD DRAWING 1101.02 (SHEET 3 OF 9), CLOSE INSIDE LANE OF OUTER I-440 AND CHANNEL TRAFFIC TO LANE 4 (SEE SHEET TCP-5).

CLOSE I-40 ENTRANCE RAMP. SEE TCP-28 FOR DETOUR.

RECONSTRUCT LANE 1, TRANSITION 5 AND LANE 2 FROM END PROJECT LIMIT TO BRIDGE OVER SUNNYBROOK RD. (SEE SHEET TCP-5).

STEP 3

USING ROADWAY STANDARD DRAWING 1101.02 (SHEET 3 OF 9), CLOSE INSIDE LANE OF OUTER I-440 AND CHANNEL TRAFFIC TO LANE 3 FOR MERGE TO LANE 4 (SEE SHEET TCP-6).

USING ROADWAY STANDARD DRAWING 1101.02 (SHEET 3 OF 9), CLOSE INSIDE LANE OF I-40 ENTRANCE RAMP (SEE SHEET TCP-6).

RECONSTRUCT LANE 2 FROM BRIDGE OVER SUNNYBROOK RD. TO LIMIT APPROXIMATELY ADJACENT TO POOLE RD. EXIT RAMP GORE (SEE SHEET TCP-6).

STEPS 4 THROUGH 7 ADDRESS LANE 2, TRANSITION 6, LANE 3, TRANSITION 3 AND LANE 2.

STEP 4

USING ROADWAY STANDARD DRAWING 1101.02 (SHEET 3 OF 9), CLOSE OUTSIDE LANE OF OUTER I-440 (SEE SHEET TCP-7).

USING ROADWAY STANDARD DRAWING 1101.02 (SHEET 3 OF 9), CLOSE INSIDE LANE OF I-40 ENTRANCE RAMP. CHANNEL RAMP TRAFFIC TO LANE 4 AND OUTSIDE SHOULDER ADJACENT TO CONSTRUCTION (SEE SHEET TCP-7).

RECONSTRUCT LANE 2, TRANSITION 6 AND LANE 3 FROM END PROJECT LIMIT TO BRIDGE OVER SUNNYBROOK RD. (SEE SHEET TCP-7).

STEP 5

USING ROADWAY STANDARD DRAWING 1101.02 (SHEET 3 OF 9), CLOSE OUTSIDE LANE OF OUTER I-440 (SEE SHEET TCP-8).

USING ROADWAY STANDARD DRAWING 1101.02 (SHEET 3 OF 9), CLOSE OUTSIDE LANE OF I-40 ENTRANCE RAMP. PLACE TEMPORARY GORE AND CHANNEL RAMP TRAFFIC TO LANE 2 FOR MERGE TO LANE 1 (SEE SHEET TCP-8).

RECONSTRUCT LANE 3 FROM BRIDGE OVER SUNNYBROOK RD. TO BEGIN TRANSITION 3 LIMIT (SEE SHEET TCP-8) (SEE SHEET TCP-9 FOR LOCATION OF BEGIN TRANSITION 3 LIMIT).

STEP 6

USING SHEET TCP-32, CLOSE INNER THREE LANES OF OUTER I-440 AND CHANNEL TRAFFIC TO LANE 5 ACROSS POOLE RD. ENTRANCE RAMP GORE.

CLOSE POOLE RD. ENTRANCE RAMP. SEE SHEET TCP-29 FOR RAMP DETOUR.

RECONSTRUCT TRANSITION 3 (SEE SHEET TCP-9).

STEP 7

USING SHEET TCP-32, CLOSE INNER THREE LANES OF OUTER I-440. CHANNEL I-440 TRAFFIC TO OUTSIDE LANE/OUTSIDE SHOULDER BEYOND US 64 BYP. GORE (SEE SHEET TCP-10).

RECONSTRUCT LANE 2 FROM END TRANSITION 3 LIMIT TO BEGIN PROJECT LIMIT AT CRABTREE CREEK (SEE SHEET TCP-10).

STEPS 8 THROUGH 11 ADDRESS LANE 3, TRANSITION 7, LANE 4, TRANSITION 4 AND LANE 3.

STEP 8

USING ROADWAY STANDARD DRAWING 1101.02 (SHEET 3 OF 9), CLOSE OUTSIDE LANE OF OUTER I-440. MAINTAIN I-440 TRAFFIC IN LANE 1 TO BRIDGE OVER SUNNYBROOK RD. (SEE SHEET TCP-11)

CLOSE I-40 ENTRANCE RAMP. SEE TCP-28 FOR DETOUR.

RECONSTRUCT EXISTING I-40 GORE, LANE 3, TRANSITION 7 AND LANE 4 FROM END PROJECT LIMIT TO BRIDGE OVER SUNNYBROOK RD. (SEE SHEET TCP-11).

STEP 9

USING ROADWAY STANDARD DRAWING 1101.02 (SHEET 3 OF 9), CLOSE OUTSIDE LANE OF OUTER I-440 (SEE SHEET TCP-12).

USING ROADWAY STANDARD DRAWING 1101.02 (SHEET 3 OF 9), CLOSE OUTSIDE LANE OF I-40 ENTRANCE RAMP AND PLACE TEMPORARY GORE TO CHANNEL RAMP TRAFFIC TO LANE 2 (SEE SHEET TCP-12).

CLOSE POOLE RD. EXIT RAMP WHEN CONSTRUCTION ACTIVITY CONFLICTS WITH RAMP ACCESS. SEE SHEET TCP-30 FOR RAMP DETOUR.

CLOSE POOLE RD. ENTRANCE RAMP WHEN CONSTRUCTION ACTIVITY IS ADJACENT TO RAMP GORE. SEE SHEET TCP-29 FOR RAMP DETOUR.

RECONSTRUCT LANE 4 FROM BRIDGE OVER SUNNYBROOK RD. TO BEGIN TRANSITION 4 LIMIT (SEE SHEETS TCP-12 & 13).

RECONSTRUCT POOLE RD. EXIT GORE AREA. (SEE SHEET TCP-13).

STEP 10

USING SHEET TCP-32, CLOSE OUTER THREE LANES OF OUTER I-440 (SEE SHEET TCP-14).

CLOSE POOLE RD. ENTRANCE RAMP. SEE SHEET TCP-29 FOR RAMP DETOUR.

RECONSTRUCT TRANSITION 4 (SEE SHEET TCP-14).

STEP 11

USING SHEET TCP-32, CLOSE OUTER TWO LANES OF OUTER I-440 (SEE SHEET TCP-27). PLACE TEMPORARY GORE ADJACENT TO POOLE RD. ENTRANCE RAMP TO CHANNEL US 64 BYP. RAMP TRAFFIC (LANE 2) TO LANE 5 (SEE SHEET TCP-15).

CLOSE POOLE RD. ENTRANCE RAMP. SEE SHEET TCP-29 FOR RAMP DETOUR.

RECONSTRUCT LANE 3 FROM END TRANSITION 4 LIMIT TO BEGIN PROJECT LIMIT AT CRABTREE CREEK (SEE SHEET TCP-15).

STEP 12

USING ROADWAY STANDARD DRAWING 1101.02 (SHEETS 3, 6 AND 7 OF 9) AND SHEET TCP-32, COMPLETE THE FOLLOWING:

- PLACE FINAL LAYER OF SURFACE COURSE ON OUTER I-440 INCLUDING I-40 RAMP AND POOLE ROAD RAMPS TO/FROM OUTER I-440. (SEE LOCAL NOTE 4 AND SHEET TCP-3 FOR OVERLAY LIMITS).
- PLACE FINAL THERMOPLASTIC PAVEMENT MARKINGS AND SNOWPLOWABLE PAVEMENT MARKERS ON OUTER I-440 INCLUDING I-40 RAMP AND POOLE ROAD RAMPS TO/FROM OUTER I-440 (SEE LOCAL NOTE 5).

APPROVED: *Michael T. Rzepa* DATE: 3-31-09



PHASING

SCALE:	NONE
DATE:	MAR 09
DWG. BY:	BLM
DESIGN BY:	GEP
REVIEWED BY:	MTR



REVISIONS	

PHASING

PHASE II

PHASE II WORK INVOLVES CONSTRUCTION ON INNER I-440. AFTER EACH WORK PERIOD, REMOVE LANE AND ROAD CLOSURES, AND REPLACE DAMAGED PAVEMENT MARKINGS.

STEPS 1 THROUGH 4 ADDRESS LANE 2, TRANSITION 1, AND LANE 3.

STEP 1

USING ROADWAY STANDARD DRAWING 1101.02 (SHEET 3 OF 9) AND SHEET TCP-32, CLOSE INSIDE 2 LANES OF INNER I-440 AND INSIDE US 64 BYP. RAMP LANE. CHANNEL I-440 TRAFFIC ONTO OUTSIDE LANE/OUTSIDE SHOULDER (SEE SHEET TCP-16).

RECONSTRUCT LANE 2 FROM BEGIN PROJECT LIMIT AT CRABTREE CREEK TO TRANSITION 1 MIDPOINT BETWEEN US 64 BYP. AND POOLE RD. INTERCHANGES (SEE SHEET TCP-16).

STEP 2

USING ROADWAY STANDARD DRAWING 1101.02 (SHEET 3 OF 9) AND SHEET TCP-32, CLOSE OUTSIDE LANES OF INNER I-440 AND INSIDE US 64 BYP. RAMP LANE (SEE SHEET TCP-17).

CLOSE US 64 BYP. ACCESS TO I-440 AND DETOUR TRAFFIC UP EXIT RAMP AND DOWN ENTRANCE RAMP AT POOLE RD. TO ACCESS I-440 (SEE SHEET TCP-17).

CLOSE INNER I-440 ACCESS TO POOLE RD. SEE SHEET TCP-29 FOR RAMP DETOUR.

RECONSTRUCT TRANSITION 1 MIDPOINT BETWEEN US 64 BYP. AND POOLE RD. INTERCHANGES TO POOLE RD. BRIDGE (SEE SHEET TCP-17).

STEP 3

USING SHEET TCP-32, CLOSE OUTSIDE LANES OF INNER I-440. PLACE TEMPORARY GORE AND MERGE AREA FOR US 64 BYP. RAMP ACCESS TO I-440 (SEE SHEET TCP-18).

CLOSE POOLE RD. ENTRANCE RAMP WHEN CONSTRUCTION ACTIVITY CONFLICTS WITH RAMP ACCESS. SEE SHEET TCP-30 FOR RAMP DETOUR.

RECONSTRUCT LANE 3 POOLE RD. BRIDGE TO BRIDGE OVER SUNNYBROOK RD. (SEE SHEET TCP-18).

STEP 4

USING SHEET TCP-32, CLOSE OUTSIDE TWO LANES OF INNER I-440. PLACE TEMPORARY GORE FOR LANE DROP FOR I-40 EXIT RAMP TRAFFIC (SEE SHEET TCP-19).

RECONSTRUCT LANE 3 FROM BRIDGE OVER SUNNYBROOK RD. TO END PROJECT LIMIT JUST BEYOND I-40 RAMP GORE.

STEPS 5 THROUGH 8 ADDRESS LANE 3, TRANSITION 2, AND LANE 4

STEP 5

USING ROADWAY STANDARD DRAWING 1101.02 (SHEET 3 OF 9) AND SHEET TCP-32, CLOSE OUTSIDE 2 LANES OF INNER I-440 AND INSIDE US 64 BYP. RAMP LANE. (SEE SHEET TCP-20).

CLOSE INNER I-440 ACCESS TO POOLE RD. SEE SHEET TCP-29 FOR RAMP DETOUR.

RECONSTRUCT LANE 3 FROM BEGIN PROJECT LIMIT AT CRABTREE CREEK TO TRANSITION 2 MIDPOINT BETWEEN US 64 BYP. AND POOLE RD. INTERCHANGES (SEE SHEET TCP-20).

STEP 6

USING SHEET TCP-32, CLOSE OUTSIDE 2 LANES OF INNER I-440. PLACE TEMPORARY GORE FOR US 64 BYP. RAMP ACCESS TO I-440 (SEE SHEET TCP-21).

CLOSE INNER I-440 ACCESS TO POOLE RD. SEE SHEET TCP-29 FOR RAMP DETOUR.

RECONSTRUCT LANE 4 FROM TRANSITION 2 MIDPOINT BETWEEN US 64 BYP. AND POOLE RD. INTERCHANGES TO POOLE RD. BRIDGE (SEE SHEET TCP-21).

STEP 7

USING ROADWAY STANDARD DRAWING 1101.02 (SHEET 3 OF 9), CLOSE OUTSIDE LANE OF INNER I-440. PLACE TEMPORARY GORE AND MERGE AREA FOR US 64 BYP. RAMP ACCESS TO I-440 (SEE SHEET TCP-22).

CLOSE INNER I-440 ACCESS TO POOLE RD. WHEN CONSTRUCTION ACTIVITY CONFLICTS WITH RAMP ACCESS. SEE SHEET TCP-29 FOR RAMP DETOUR.

CLOSE POOLE RD. ENTRANCE RAMP WHEN CONSTRUCTION ACTIVITY CONFLICTS WITH RAMP ACCESS. SEE SHEET TCP-30 FOR RAMP DETOUR.

RECONSTRUCT LANE 4 POOLE RD. BRIDGE TO BRIDGE OVER SUNNYBROOK RD. (SEE SHEET TCP-22).

STEP 8

USING SHEET TCP-32, CLOSE OUTSIDE TWO LANE OF INNER I-440 (SEE SHEET TCP-23).

CLOSE I-40 EXIT RAMP. SEE SHEET TCP-28 FOR RAMP DETOUR.

RECONSTRUCT LANE 4 AND I-40 EXIT RAMP/GORE FROM BRIDGE OVER SUNNYBROOK RD. TO END PROJECT LIMIT JUST BEYOND I-40 RAMP GORE (SEE SHEET TCP-23).

STEP 9 ADDRESSES LANE 2 FROM ADJACENT TO POOLE RD. ENTRANCE RAMP GORE TO END PROJECT LIMIT.

STEP 9

USING TCP-32, CLOSE INSIDE THREE LANES OF INNER I-440 (SEE SHEET TCP-24).

RECONSTRUCT LANE 2 FROM APPROXIMATELY ADJACENT TO POOLE RD. ENTRANCE RAMP GORE TO END PROJECT LIMIT JUST BEYOND I-40 RAMP GORE (SEE SHEET TCP-24).

WHEN CONSTRUCTION ACTIVITY IS IN PROXIMITY TO I-40 EXIT RAMP, PLACE TEMPORARY GORE TO CHANNEL I-440 TRAFFIC THROUGH GORE AREA (SEE SHEET TCP-25).

STEP 10

USING ROADWAY STANDARD DRAWING 1101.02 (SHEET 3 OF 9), CLOSE OUTSIDE LANE OF INNER I-440 AND OUTSIDE LANE OF US 64 BYP. RAMP. PLACE TEMPORARY GORE FOR US 64 BYP. RAMP ACCESS TO I-440 (SEE SHEET TCP-26).

CLOSE POOLE RD. EXIT RAMP. SEE SHEET TCP-29 FOR RAMP DETOUR.

RECONSTRUCT SEGMENT OF LANE 5 AND POOLE RD. GORE. (SEE SHEET TCP-26).

STEP 11

USING ROADWAY STANDARD DRAWING 1101.02 (SHEET 3 OF 9), CLOSE OUTSIDE LANE OF INNER I-440 IN POOLE RD. INTERCHANGE AREA. (SEE SHEET TCP-27).

CLOSE POOLE RD. ENTRANCE RAMP. SEE SHEET TCP-30 FOR RAMP DETOUR.

RECONSTRUCT POOLE RD. GORE AND ACCELERATION/TAPER PAVEMENT (SEE SHEET TCP-27).

STEP 12

USING ROADWAY STANDARD DRAWING 1101.02 (SHEETS 3, 6 AND 7 OF 9) AND SHEET TCP-32, COMPLETE THE FOLLOWING:



- PLACE FINAL LAYER OF SURFACE COURSE ON INNER I-440 INCLUDING I-40 RAMP AND POOLE ROAD RAMPS TO/FROM INNER I-440. (SEE LOCAL NOTE 4 AND SHEET TCP-3 FOR OVERLAY LIMITS).
- PLACE FINAL THERMOPLASTIC PAVEMENT MARKINGS AND SNOWPLOWABLE PAVEMENT MARKERS ON INNER I-440 INCLUDING I-40 RAMP AND POOLE ROAD RAMPS TO/FROM INNER I-440 (SEE LOCAL NOTE 5).

STEP 13

REMOVE WORK ZONE TRAFFIC CONTROL DEVICES.

KO & ASSOCIATES, P.C.
Consulting Engineers
 A Florence & Hutcheson, Inc. Company
 5121 KINGDOM WAY, SUITE 100 RALEIGH, N.C. 27607
 (919) 851-6066

PROJ. REFERENCE NO.	SHEET NO.
I-5114	TCP-4A

APPROVED: <i>Michael T. Rietz</i> DATE: 3-25-09		PHASING	
SEAL 	SCALE: NONE		REVISIONS
	DATE: MAR 09		
	DWG. BY: BLM		
	DESIGN BY: GEP		
	REVIEWED BY: MTR		

r:\plans\5114\1c_tcp_phasing.dgn
 3/25/2009 11:27:10 AM

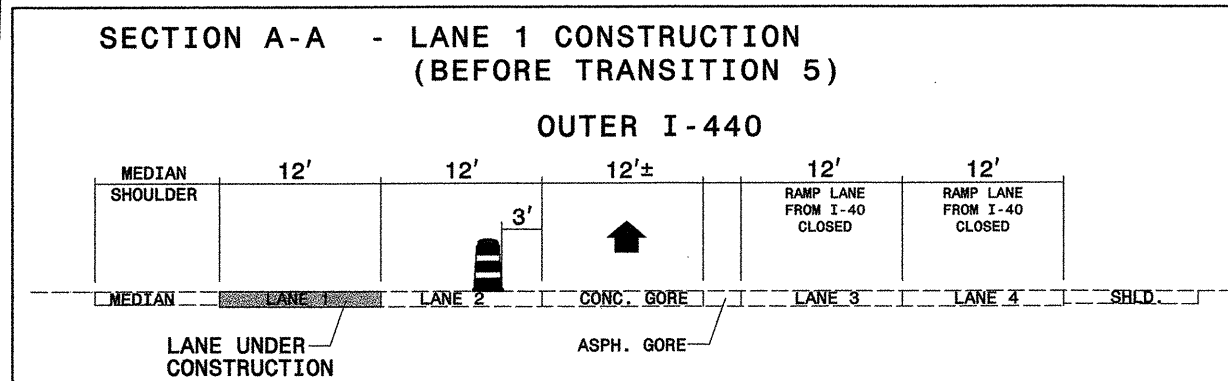
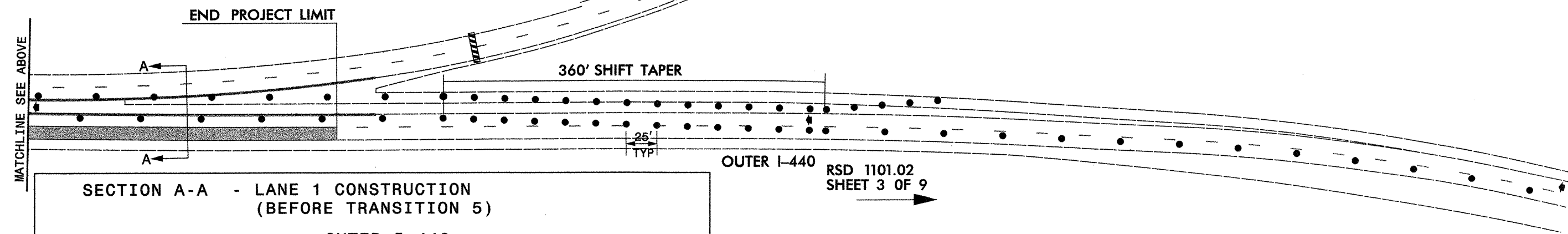
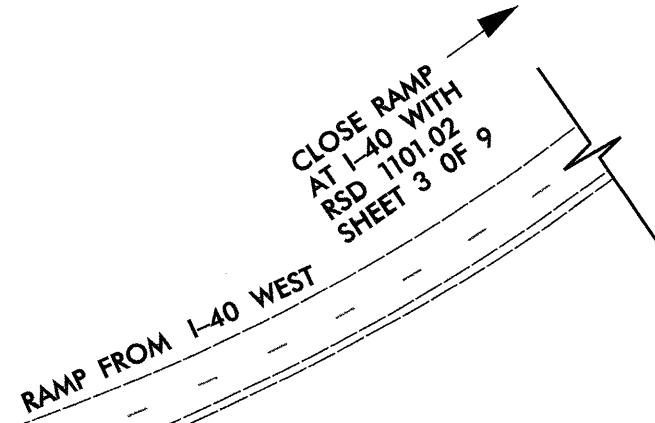
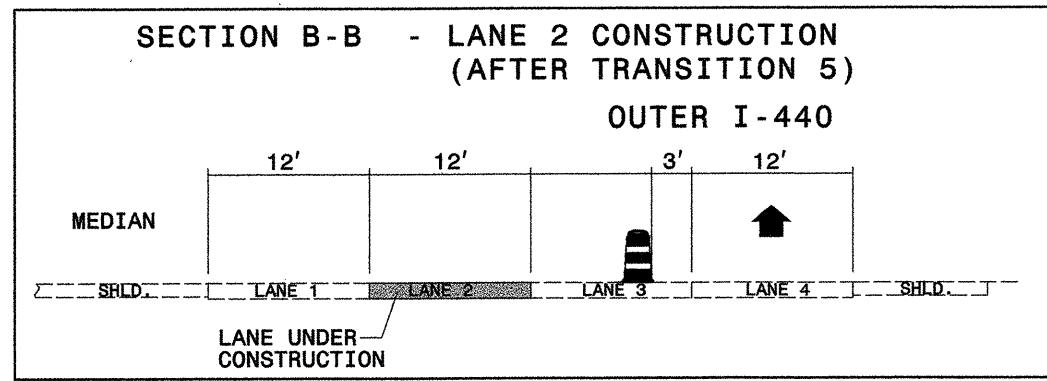
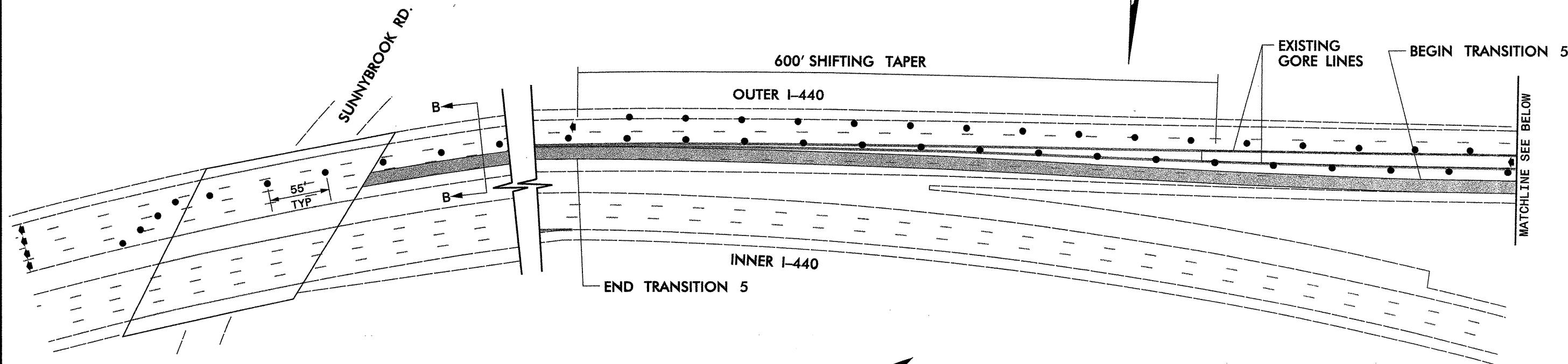

APPROVED: *Michael T. Rzepka* DATE: 3-25-09

SEAL



OUTER I-440 LANE 1 & TRANSITION 5 & LANE 2 CONST. AT I-40 RAMP

SCALE:	NONE		REVISIONS
DATE:	MAR 09		
DWG. BY:	BLM		
DESIGN BY:	GEP		
REVIEWED BY:	MTR		

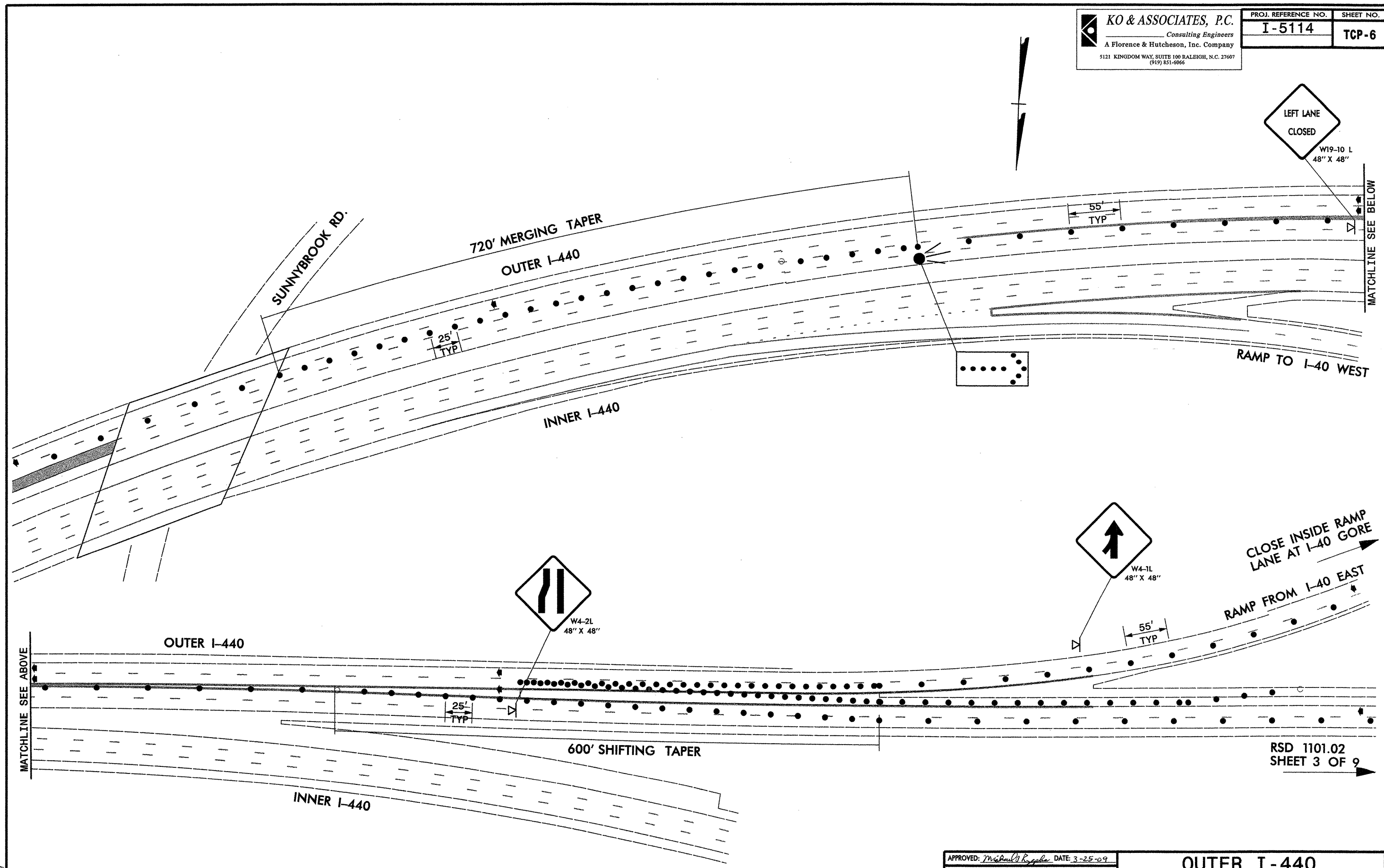
r:\plans\5114_fc_top_outier_lane1_trans_lane2_140_wzd.dgn
 3/25/2009 11:47:40 AM



r:\plans\5114_fc_top_outer_lane2_140_wzdd.dgn
 3/25/2009 11:17:59 AM

APPROVED: <i>Michael T. Riepa</i> DATE: 3-25-09	OUTER I-440 LANE 2 CONST. AT I-40	
SEAL 	SCALE: NONE	
	DATE: MAR 09	
	DWG. BY: BLM	
	DESIGN BY: GEP	
REVIEWED BY: MTR	REVISIONS	

RSD 1101.02
 SHEET 3 OF 9

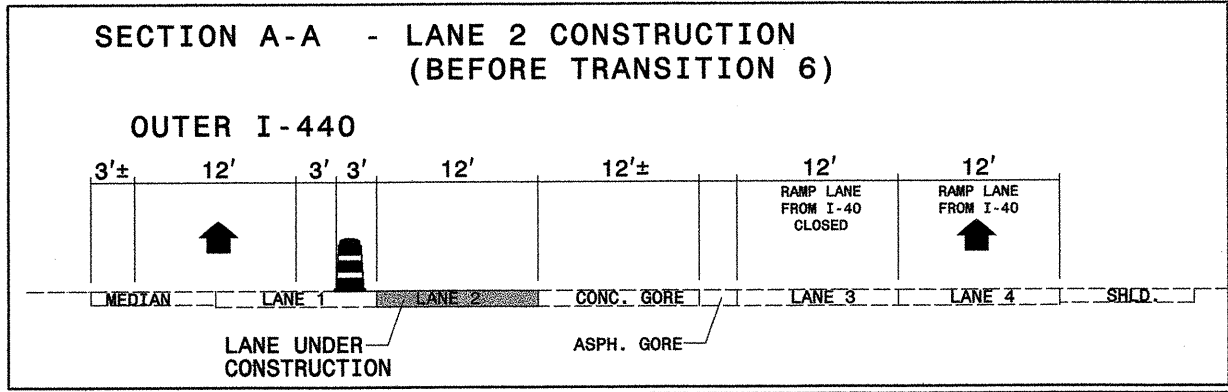
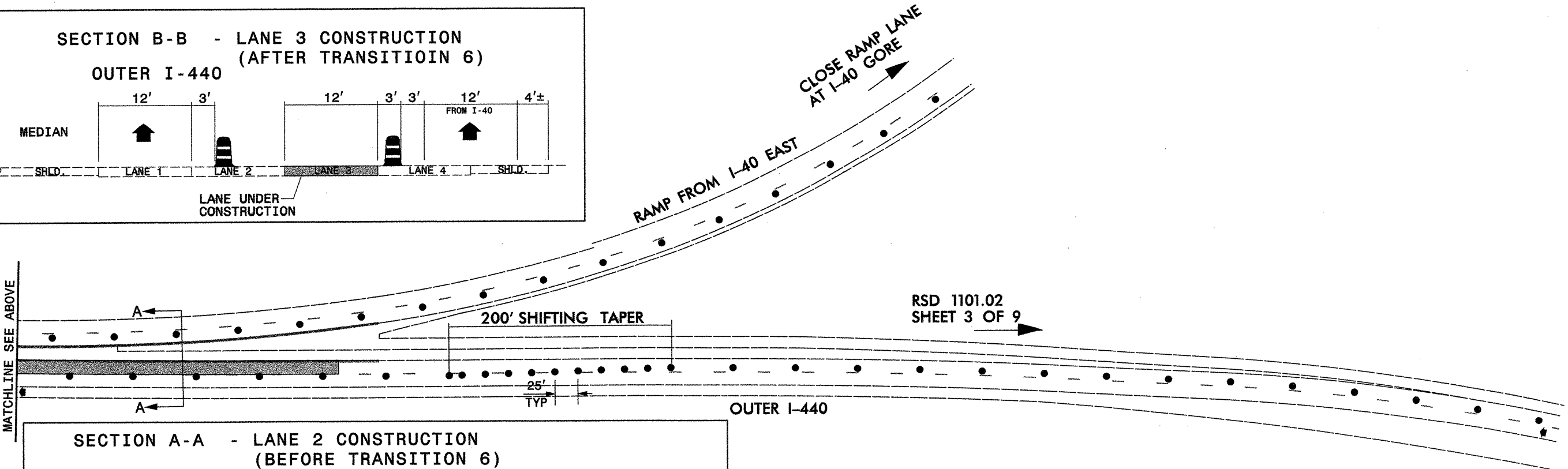
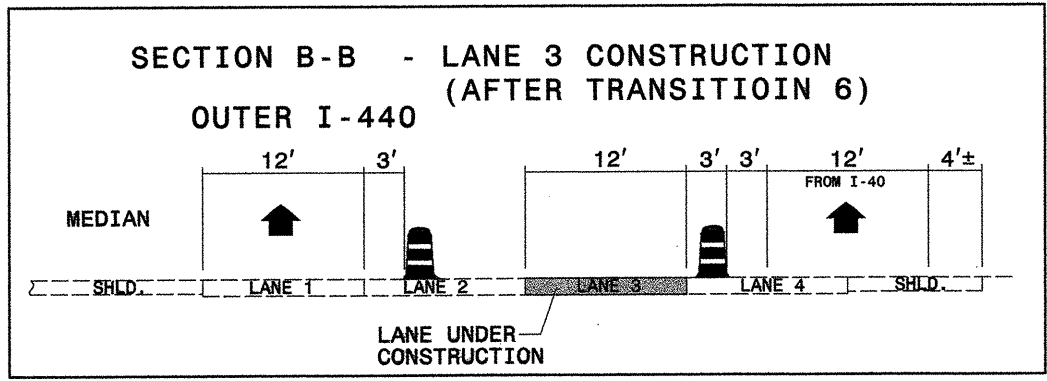
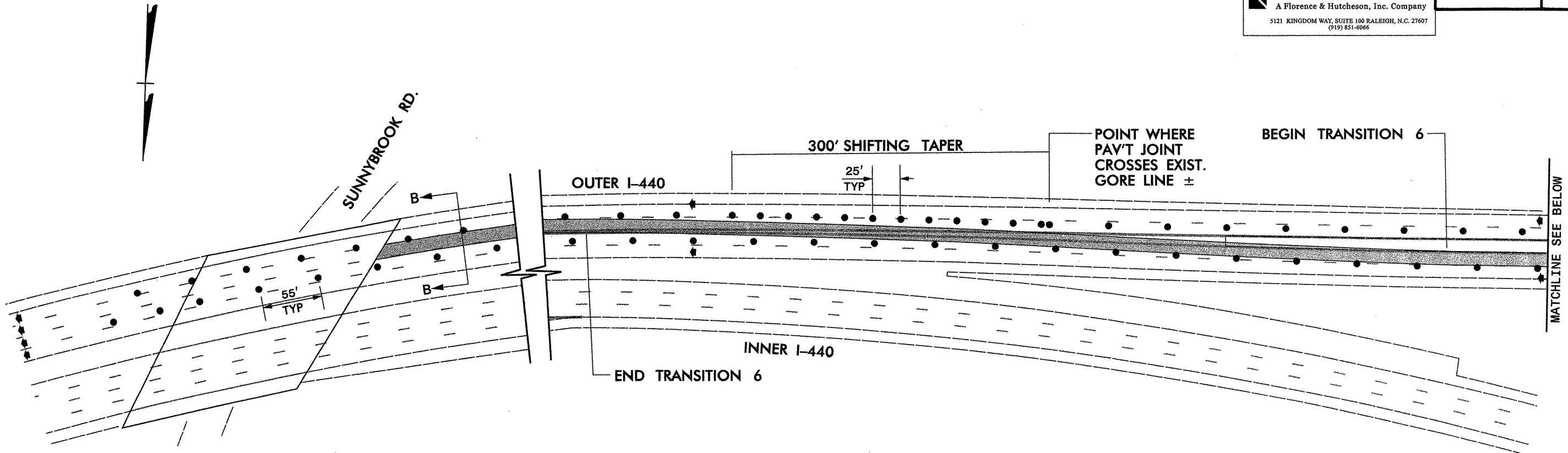

APPROVED: *Michael T. Hepp* DATE: 3-25-09

OUTER I-440 LANE 2 & TRANSITION 6 & LANE 3 CONST. AT I-40 RAMP

SCALE: NONE
 DATE: MAR 09
 DWG. BY: BLM
 DESIGN BY: GEP
 REVIEWED BY: MTR

SEAL
 NORTH CAROLINA PROFESSIONAL ENGINEER
 SEAL 15876
 MICHAEL T. HEPP

REVISIONS

r:\plans\5114_fc_top_outlet_lane2_trans_lane3_i40_vrzd.dgn
 3/25/2009 11:28 AM

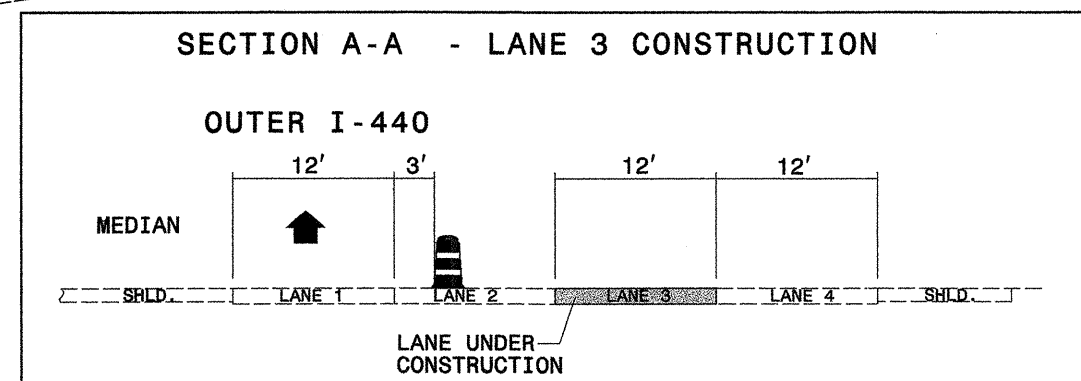
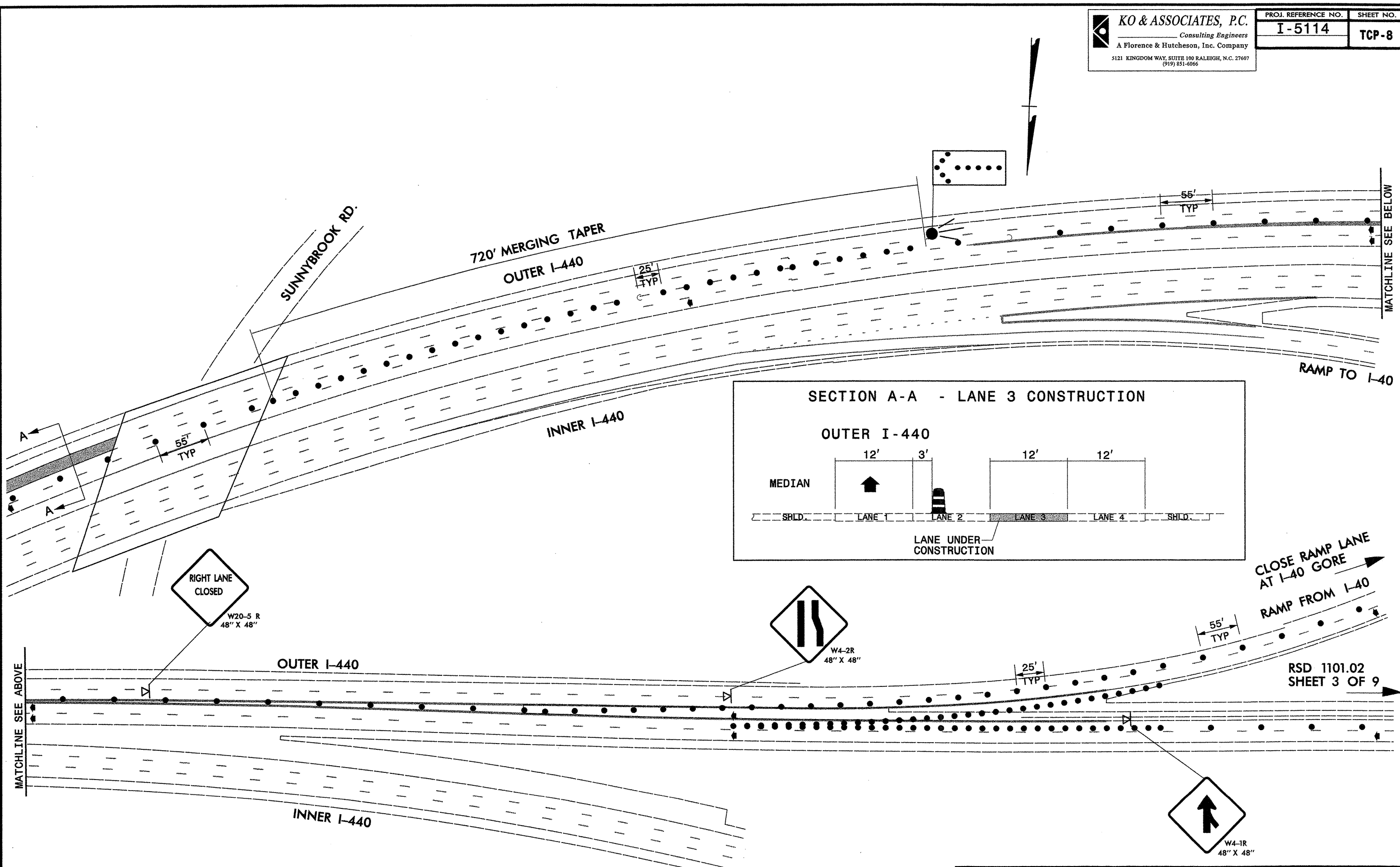

r:\plans\5114\1c_top_outer_lane3_140_poole_wzd.dgn
 3/25/2009 11:50:00 AM

APPROVED: <i>Michael J. K...</i> DATE: 3-25-09	OUTER I-440 LANE 3 CONST. AT I-40	
	SCALE: NONE	
	DATE: MAR 09	
	DWG. BY: BLM	
	DESIGN BY: GEP	
REVIEWED BY: MTR	REVISIONS	

RSD 1101.02
SHEET 3 OF 9

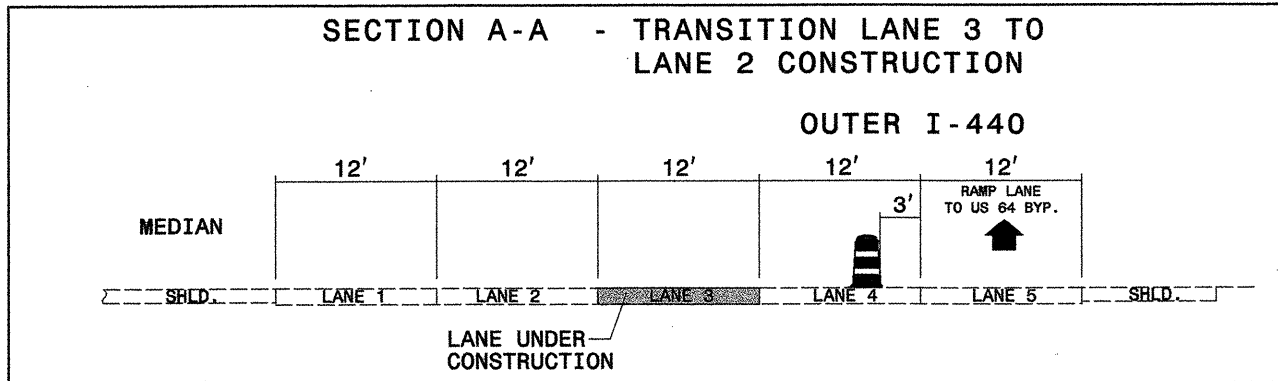
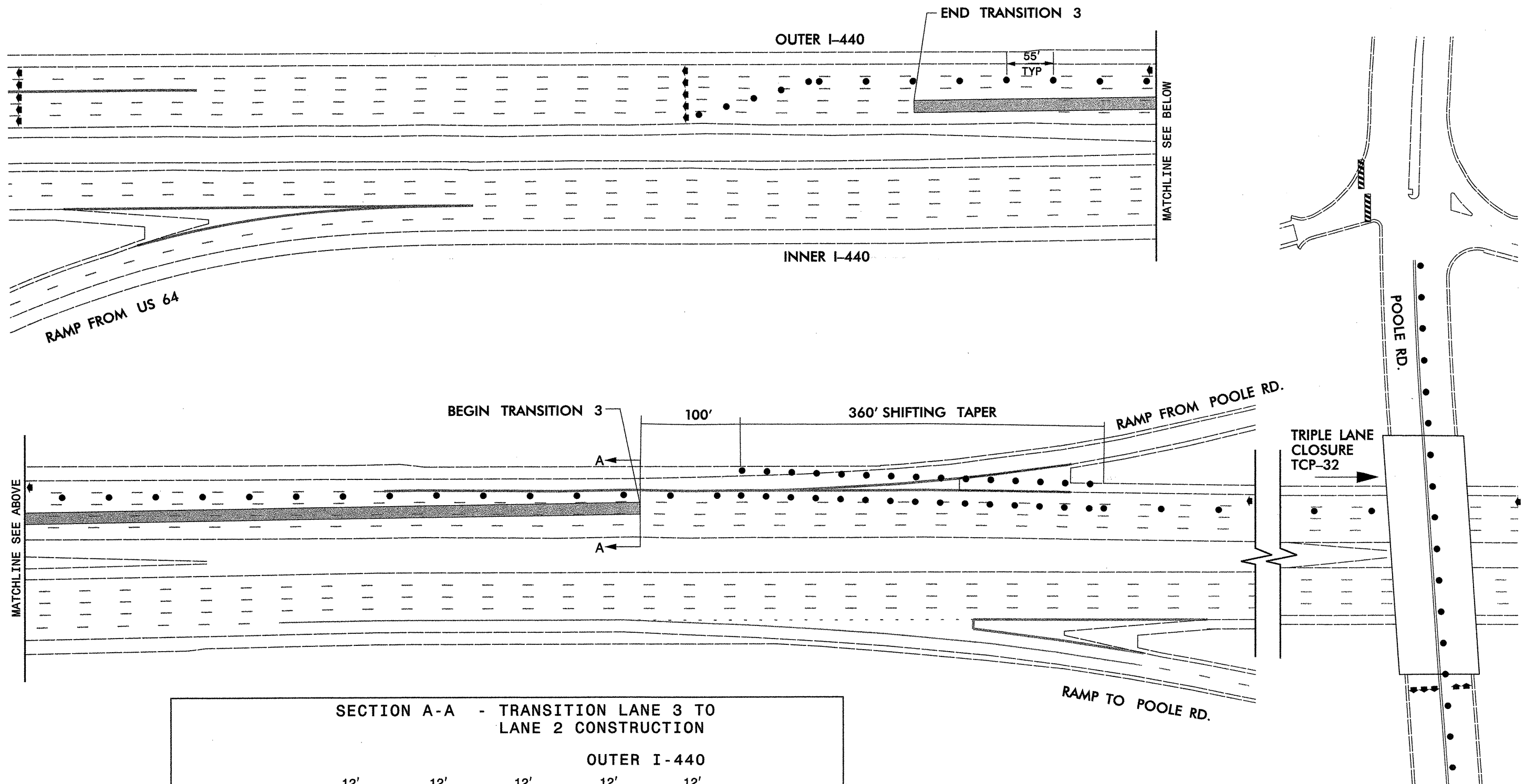
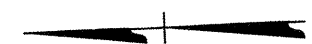

APPROVED: *Michael T. Kiepma* DATE: 3-25-09

SEAL

**OUTER I-440 TRANSITION 3
 CONST. AT US 64**

SCALE:	NONE		REVISIONS _____ _____ _____
DATE:	MAR 09		
DWG. BY:	BLM		
DESIGN BY:	GEP		
REVIEWED BY:	MTR		

r:\plans\5114\to_top_outer_lane3_trans_lane2_us64_wzd.dgn
 3/25/2009 11:58:20 AM

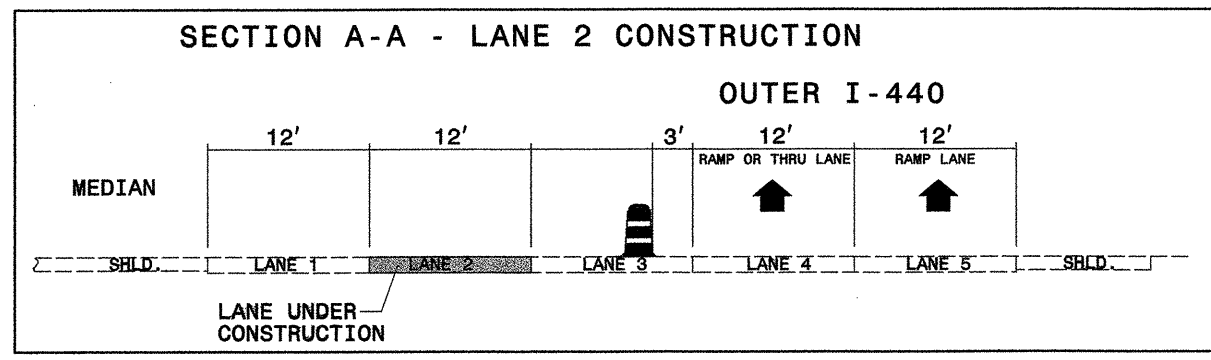
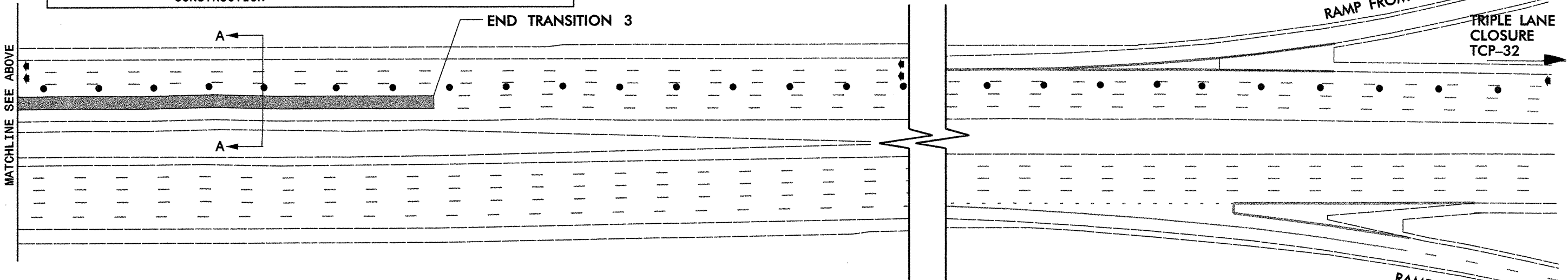
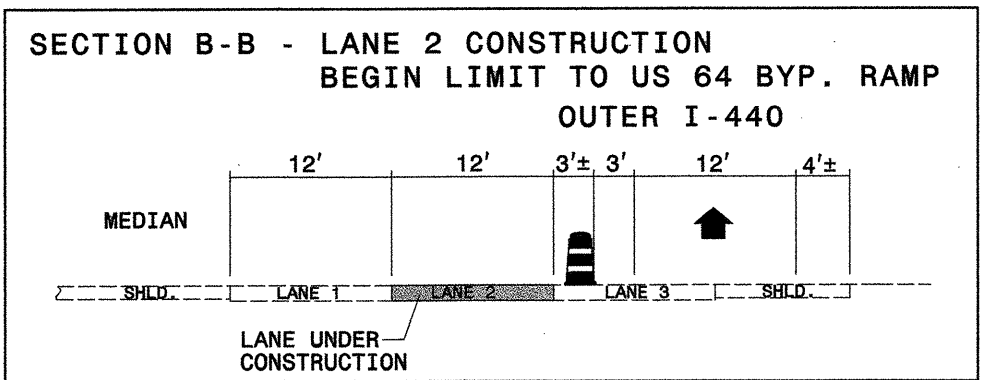
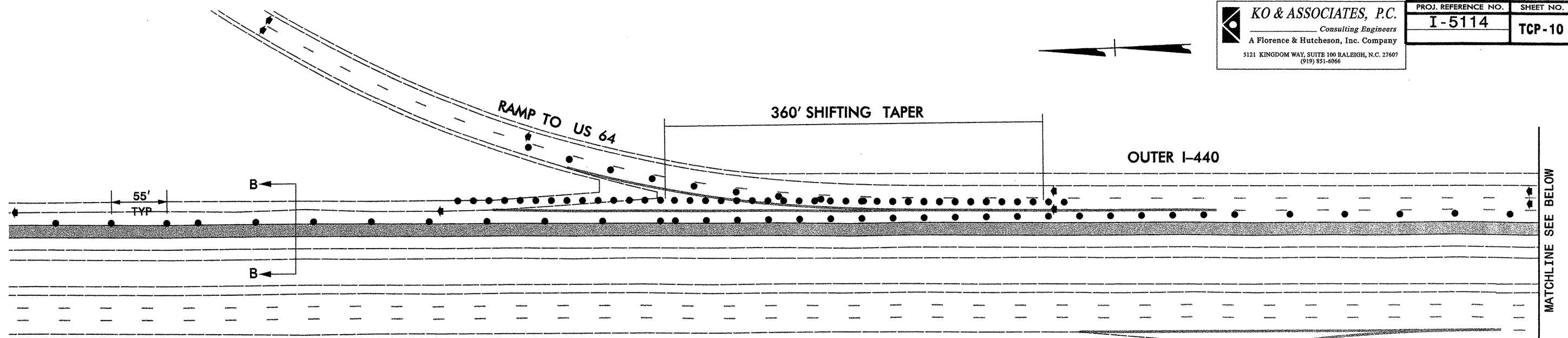
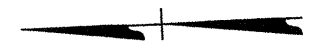

APPROVED: *M. J. [Signature]* DATE: 3-25-09

SEAL

**OUTER I-440 LANE 2
 CONST. AT US 64**

SCALE: NONE		REVISIONS
DATE: MAR 09		
DWG. BY: BLM		
DESIGN BY: GEP		
REVIEWED BY: MTR		

r:\plans\5114_top_outer_lane2_us64_wzd.dgn
 3/25/2009 11:48:32 AM



END TRANSITION 7

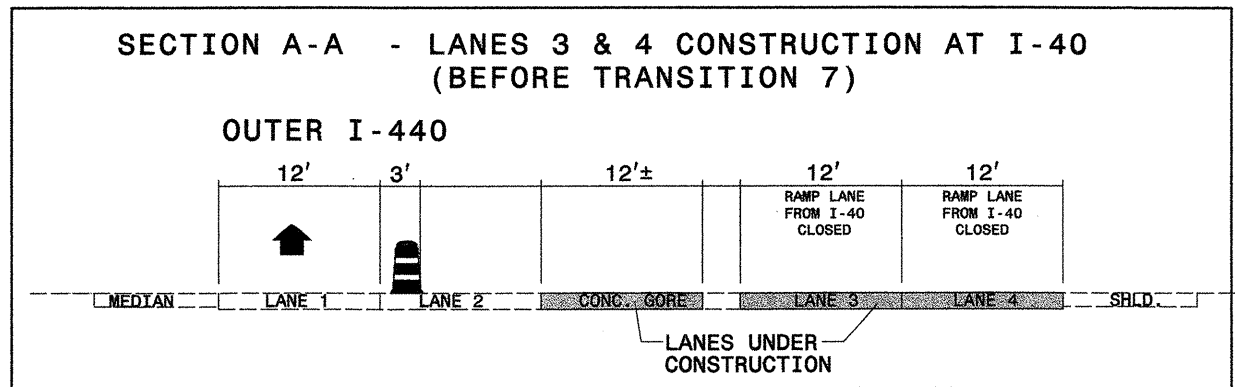
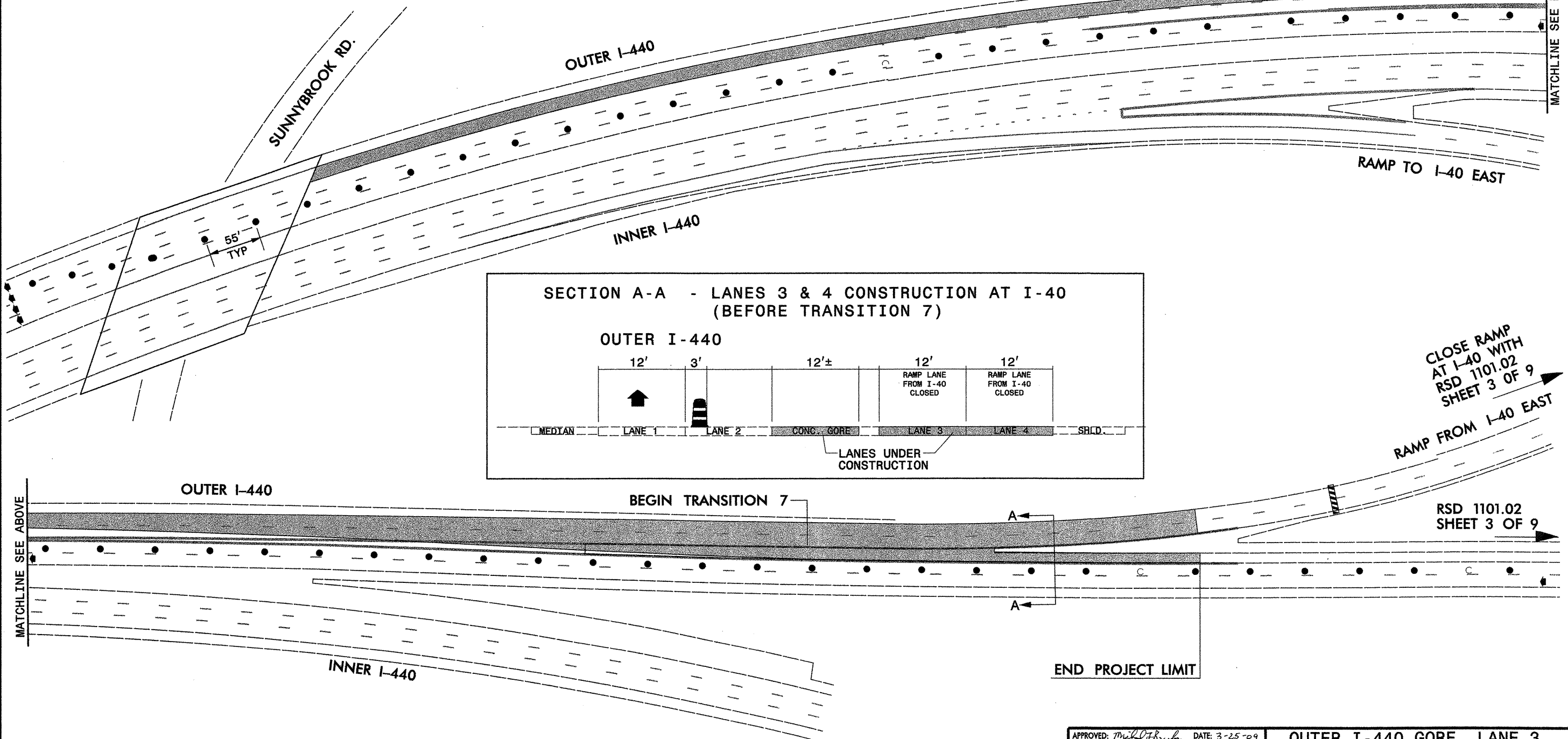

**CLOSE RAMP
 AT I-40 WITH
 RSD 1101.02
 SHEET 3 OF 9**

RAMP FROM I-40 EAST

**RSD 1101.02
 SHEET 3 OF 9**

r:\plans\5114_fc_top_outer_lane3_trans_lane4_entrance_140_wrd.dgn
 3/25/2009 11:48:43 AM

APPROVED: *Michael T. Rzepka* DATE: 3-25-09

**OUTER I-440 GORE, LANE 3,
 TRANSITION 7 & LANE 4
 CONST. AT I-40**

SCALE: NONE		REVISIONS
DATE: MAR 09		
DWG. BY: BLM		
DESIGN BY: GEP		

REVIEWED BY: MTR

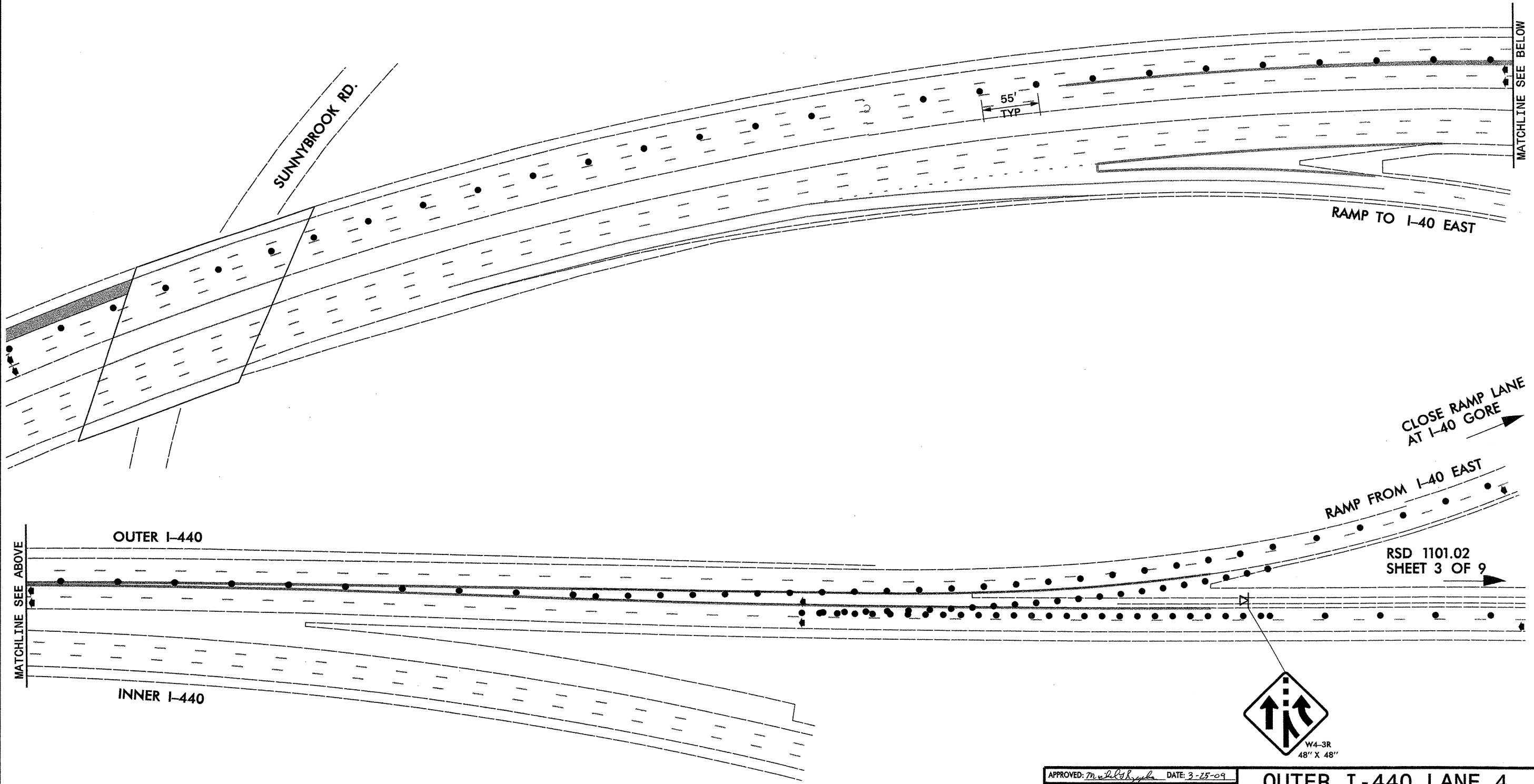
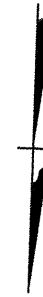

CLOSE RAMP LANE
AT I-40 GORE

RAMP FROM I-40 EAST

RAMP TO I-40 EAST

OUTER I-440

INNER I-440

RSD 1101.02
SHEET 3 OF 9

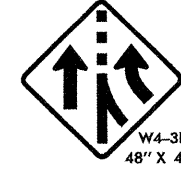

W4-3R
48" X 48"

APPROVED: *m. [signature]* DATE: 3-25-09

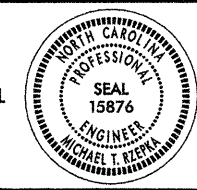

**OUTER I-440 LANE 4
CONST. AT I-40**

SCALE: NONE
 DATE: MAR 09
 DWG. BY: BLM
 DESIGN BY: GEP
 REVIEWED BY: MTR



REVISIONS

r:\plans\5114_tcp_outer_lane4_lane4_wzd.dgn
 3/25/2009 11:59:08 AM

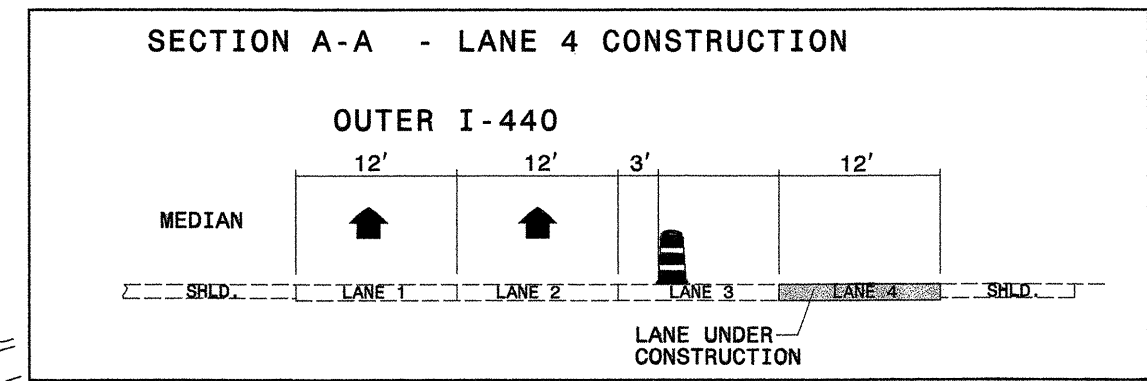
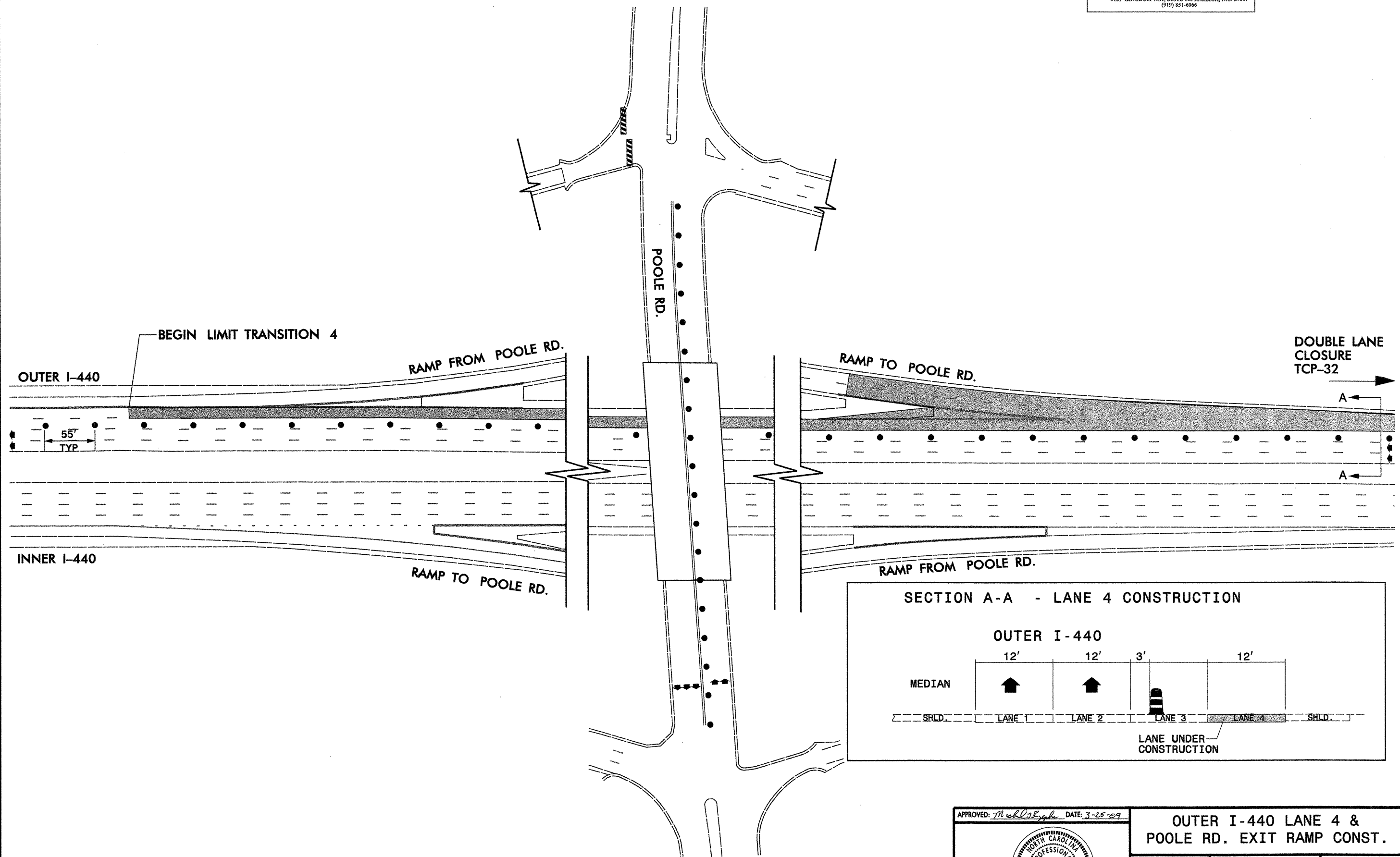

APPROVED: <i>M. Kiepl</i> DATE: 3-25-09	<p>OUTER I-440 LANE 4 & POOLE RD. EXIT RAMP CONST.</p>	
SCALE: NONE		REVISIONS
DATE: MAR 09		
DWG. BY: BLM		
DESIGN BY: GEP		
REVIEWED BY: MTR		

r:\plans\5114_tc_top_outer_lane4_poole_ond_exit_wzd.dgn
 3/25/2009 11:51:16 AM

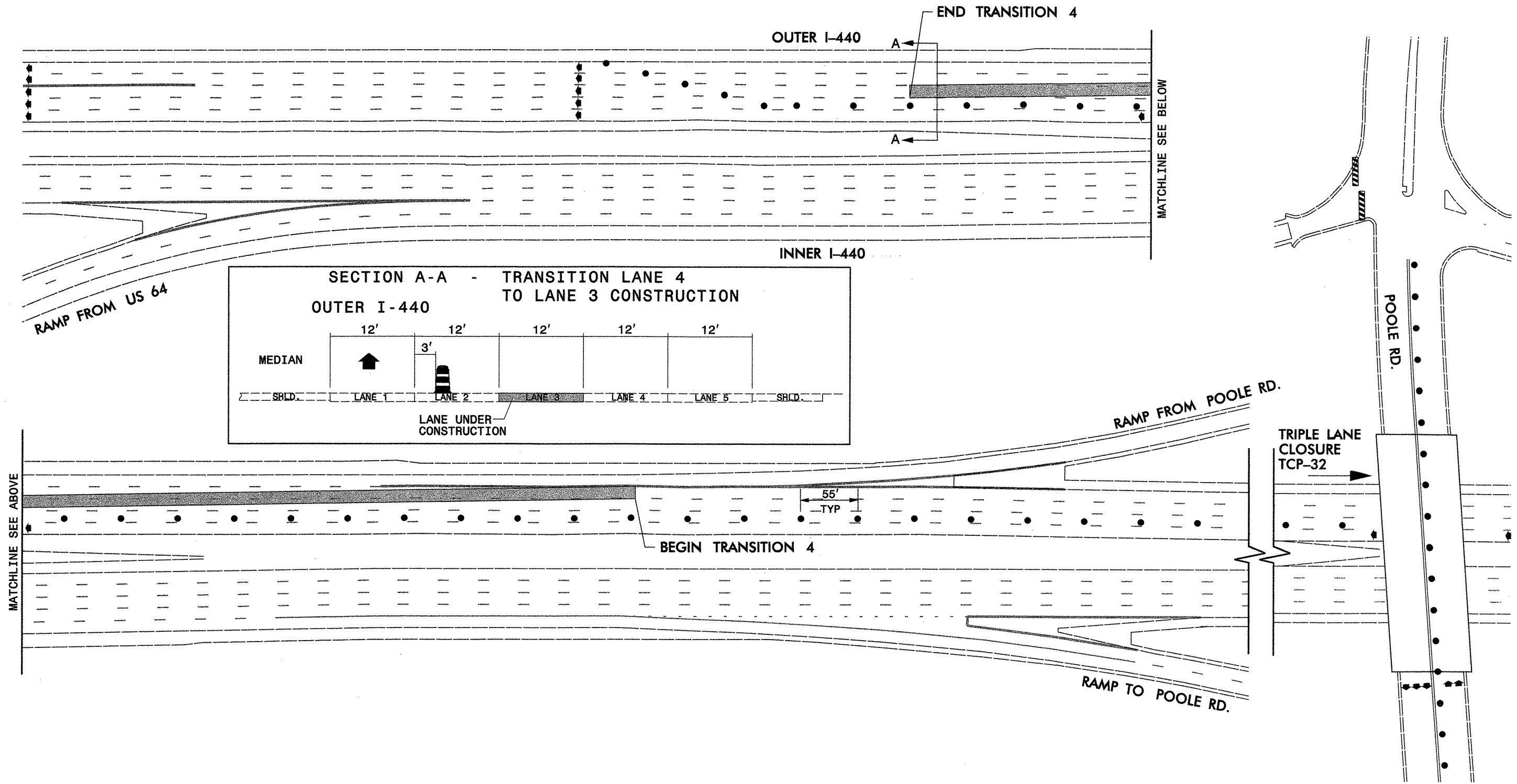

r:\plans\5114_top_outer_lane4_trans_lane3_us64_wzd.dgn
 3/25/2009 11:09:24 AM

APPROVED: <i>Michael T. Rzepka</i> DATE: 3-25-09	OUTER I-440 TRANSITION 4 CONST. AT US 64	
	SCALE: NONE	
	DATE: MAR 09	
	DWG. BY: BLM	
	DESIGN BY: GEP	
REVIEWED BY: MTR	REVISIONS	

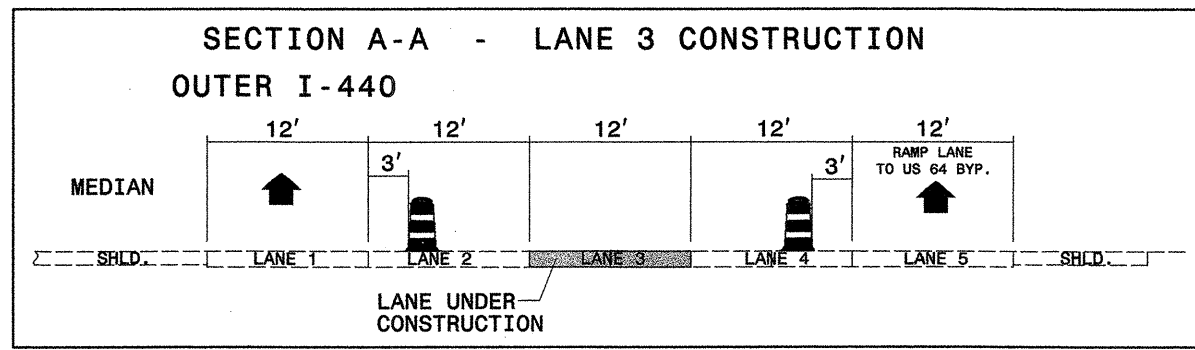
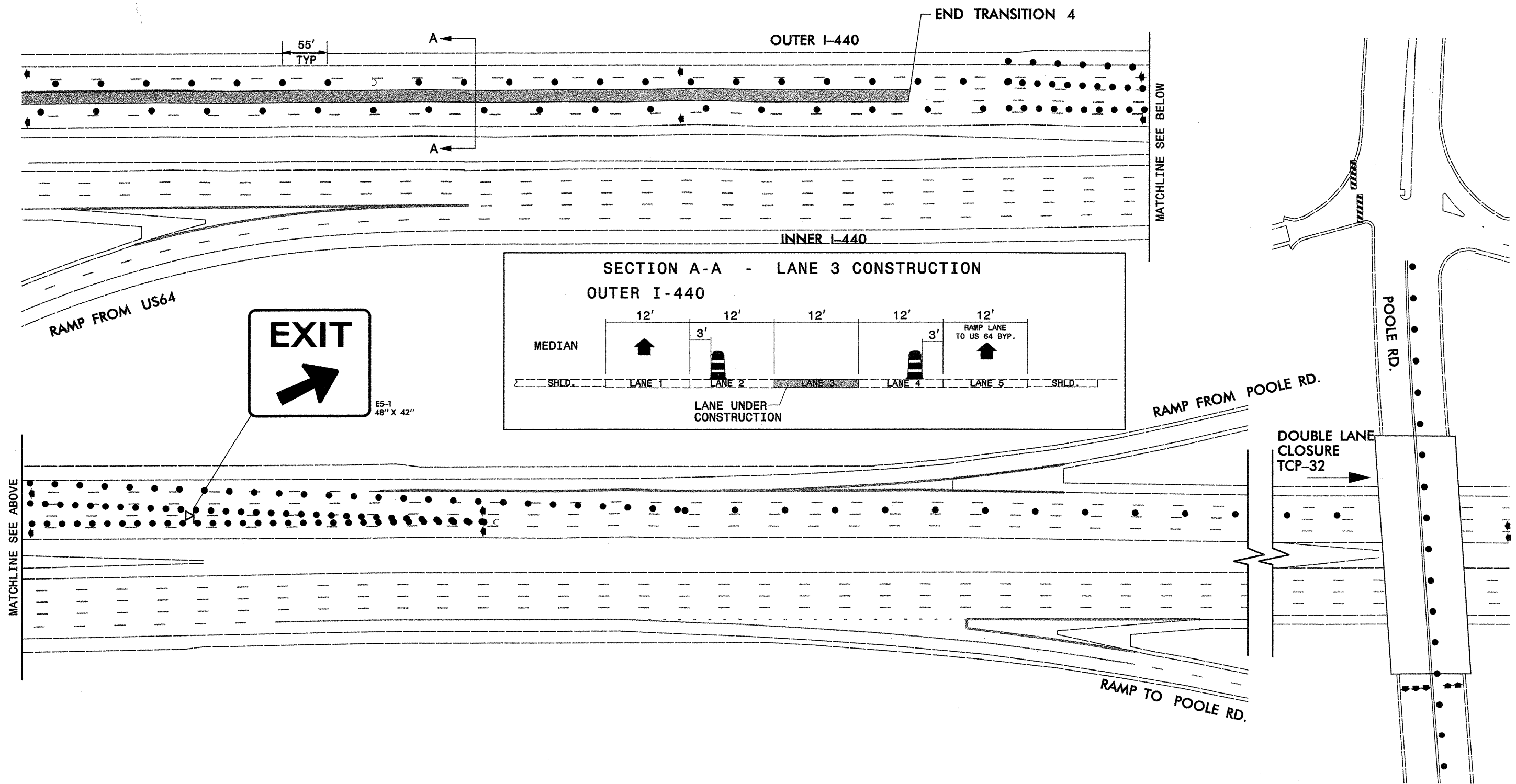
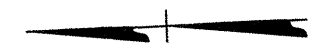

MATCHLINE SEE ABOVE

MATCHLINE SEE BELOW

APPROVED: *Michael T. Kiepp* DATE: 3-25-09

SEAL

**OUTER I-440 LANE 3
 CONST. AT US 64**

SCALE: NONE		REVISIONS
DATE: MAR 09		
DWG. BY: BLM		
DESIGN BY: GEP		
REVIEWED BY: MTR		

r:\plans\5114_top_outer_lane3_us64_wzd.dgn
 3/25/2009 11:59:32 AM

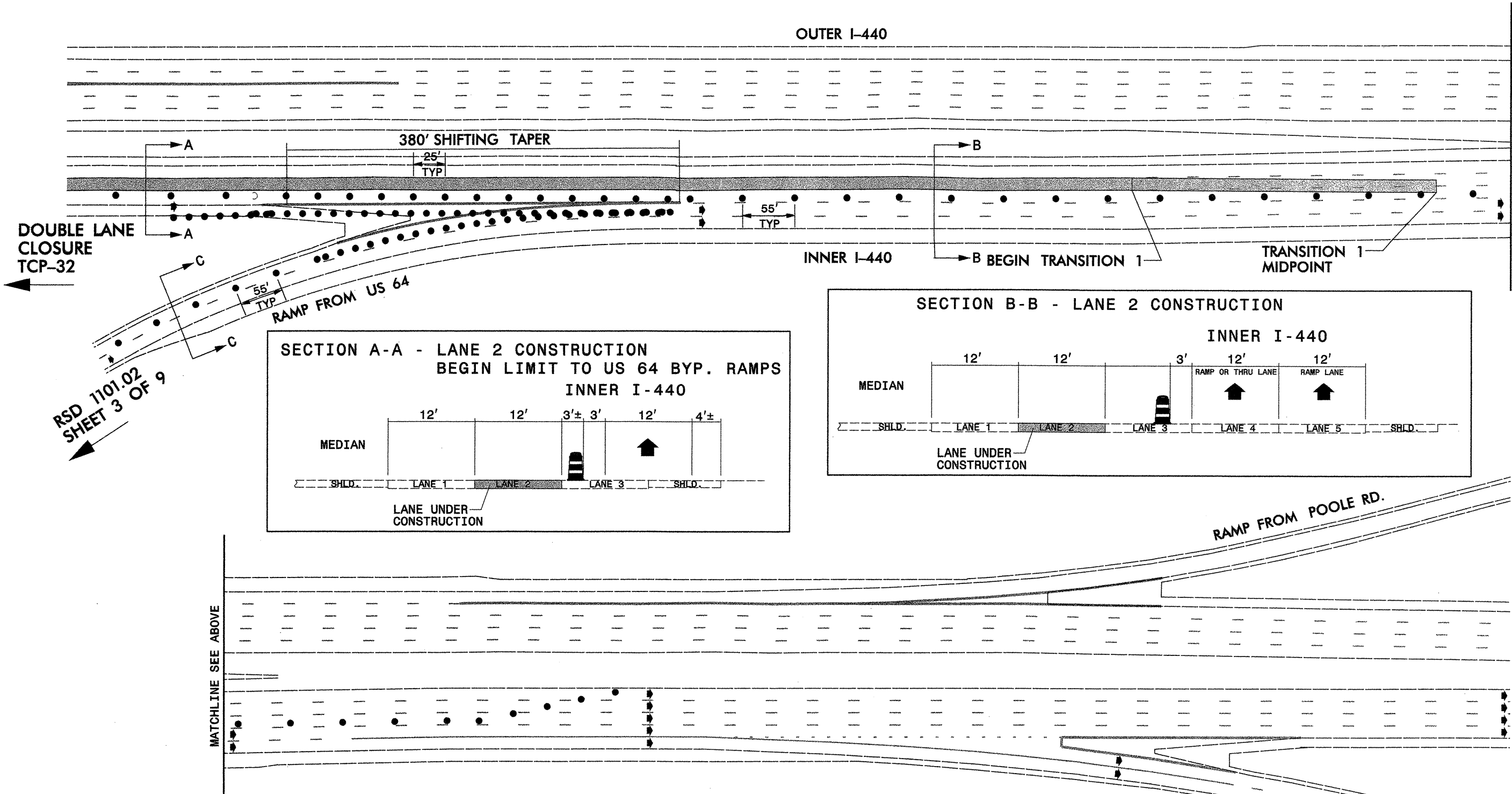
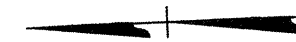

DOUBLE LANE CLOSURE
TCP-32

RSD 1101.02
SHEET 3 OF 9

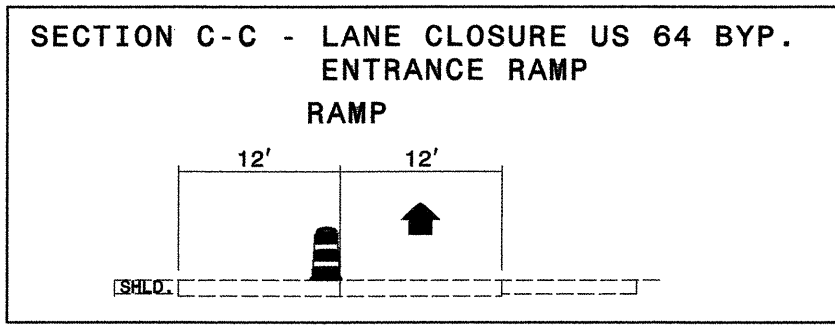
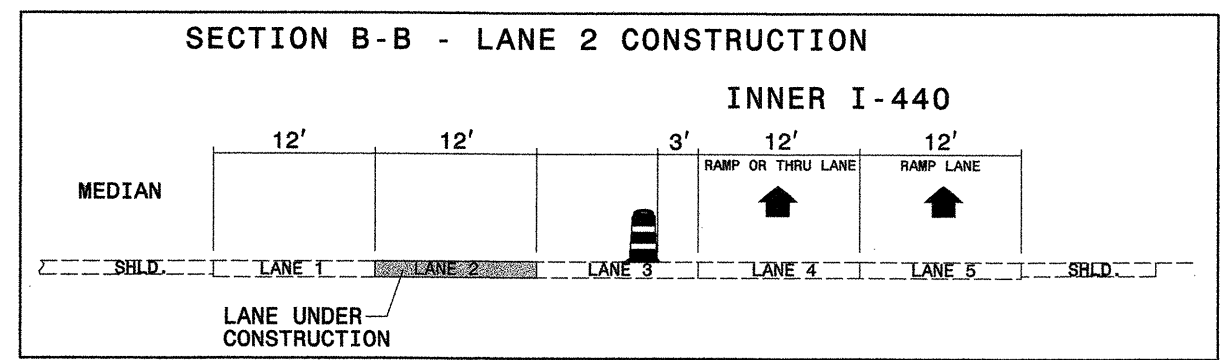
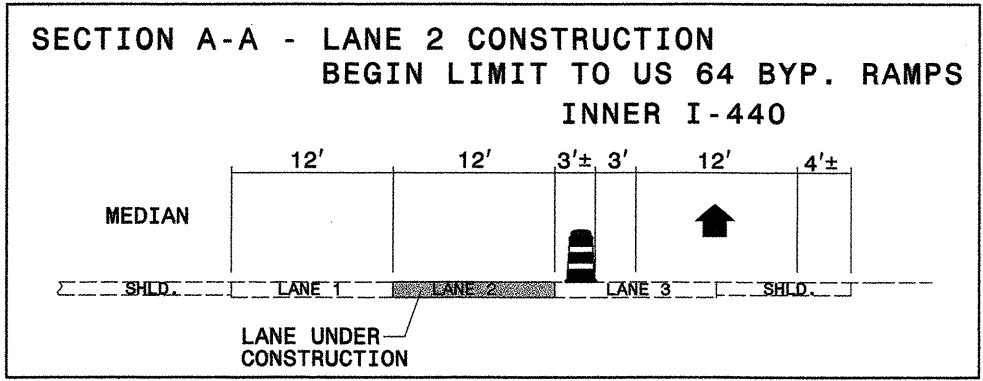

APPROVED: *Michael T. Kleppa* DATE: 3-25-09

SEAL

**INNER I-440 LANE 2
& TRANSITION 1 CONST.
AT US 64**

SCALE: NONE		REVISIONS
DATE: MAR 09		
DWG. BY: BLM		
DESIGN BY: GEP		
REVIEWED BY: MTR		

R:\Plans\15114_Top_Inner_Lane2_Trans_US64.wzd.dgn
3/25/2009 12:44:55 PM

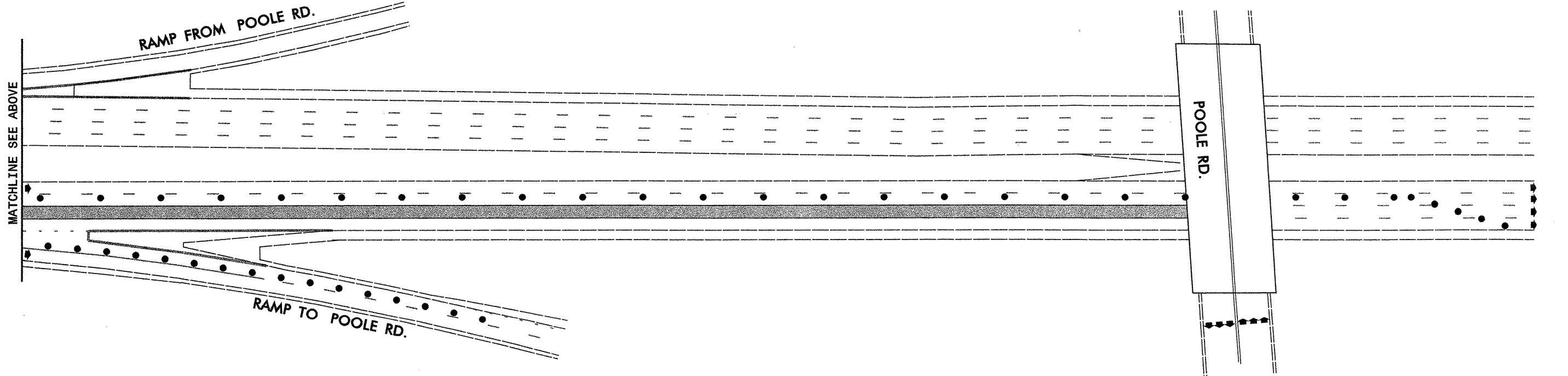
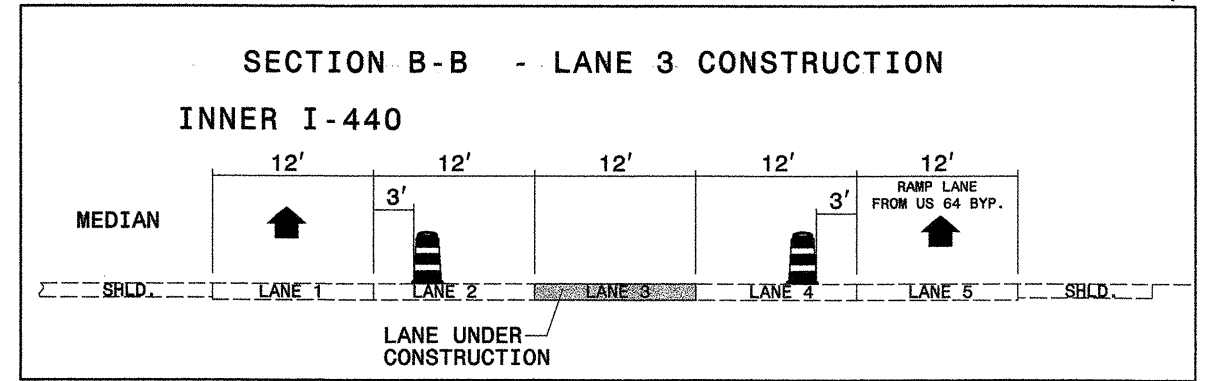
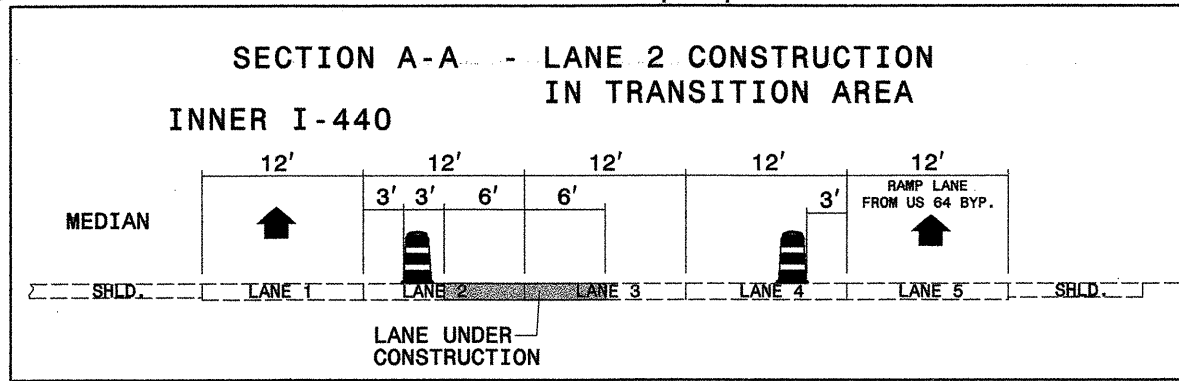
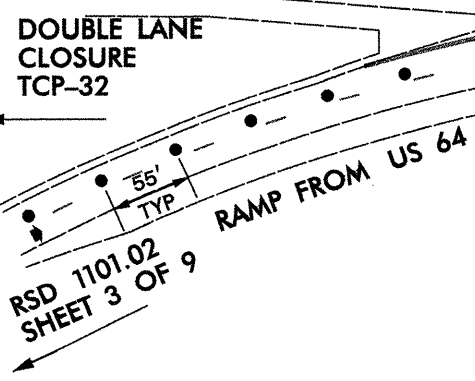
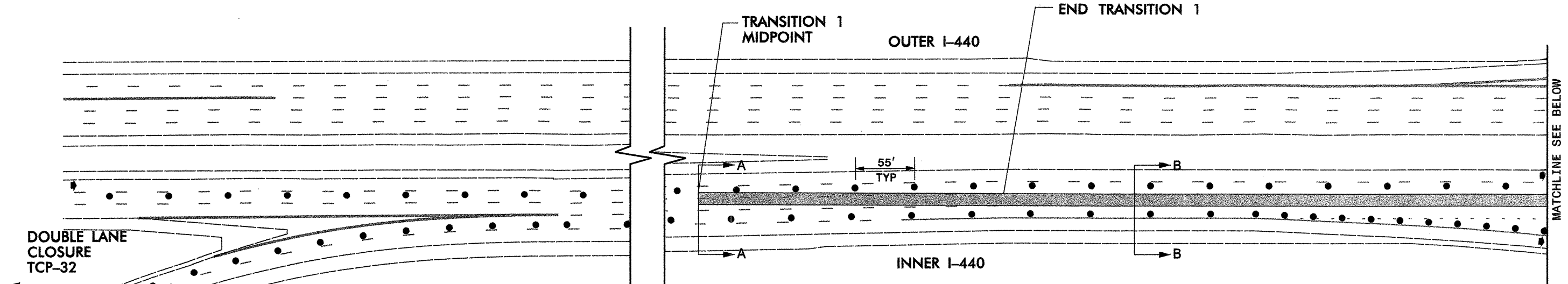
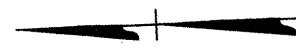

APPROVED: *M. J. [Signature]* DATE: 3-25-09

SEAL

INNER I-440 TRANSITION 1 & LANE 3 CONST. AT US 64

SCALE: NONE		REVISIONS
DATE: MAR 09		
DWG. BY: BLM		
DESIGN BY: GEP		
REVIEWED BY: MTR		

r:\plans\5114-10_top_inner_trans_lane3_us64_wzd.dgn
 3/25/2009 11:09:49 AM

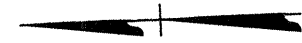

OUTER I-440

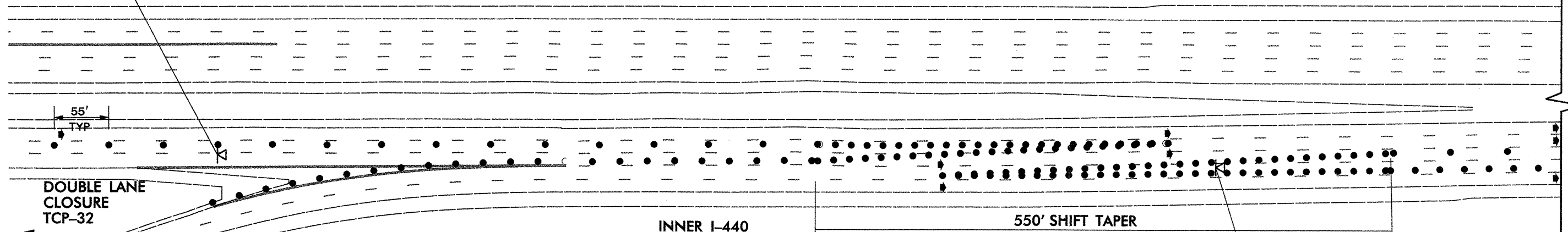

BREAKLINE SEE BELOW

INNER I-440

550' SHIFT TAPER

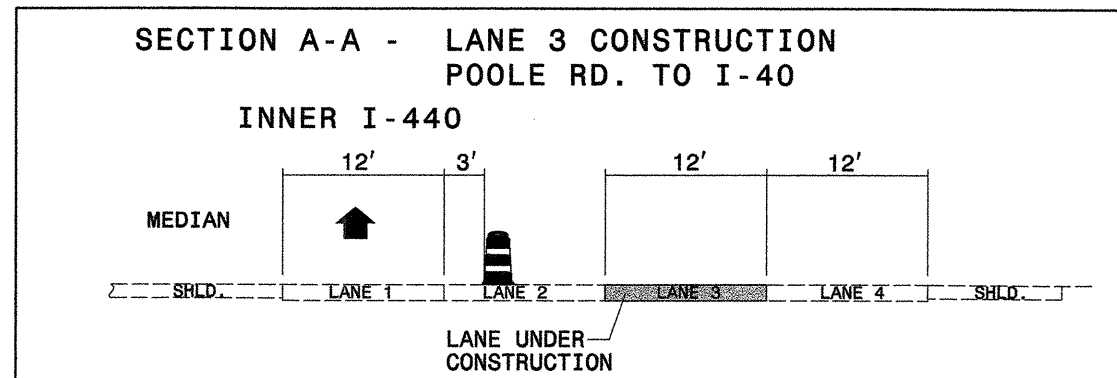
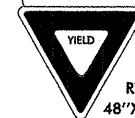

DOUBLE LANE CLOSURE
TCP-32

RAMP FROM US 64

RAMP FROM POOLE RD.

BREAKLINE SEE ABOVE

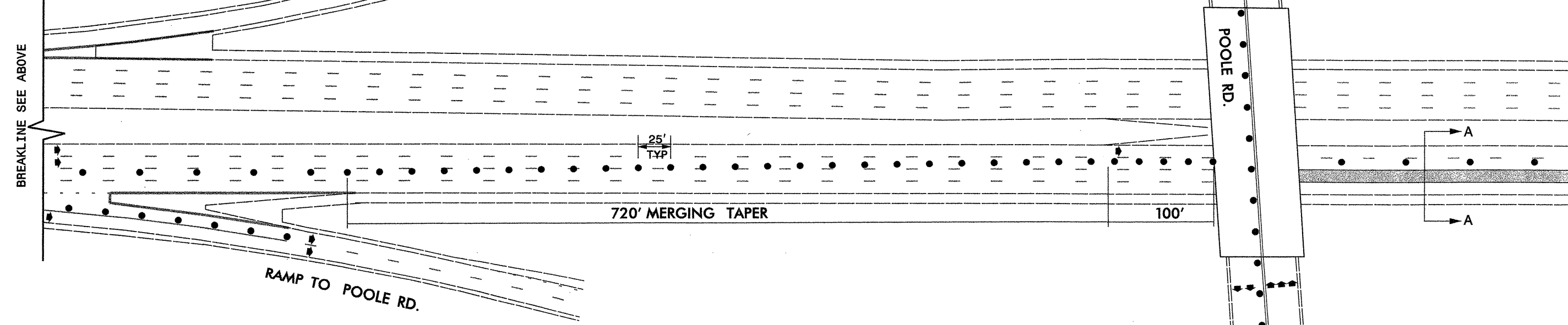

720' MERGING TAPER

100'

RAMP TO POOLE RD.

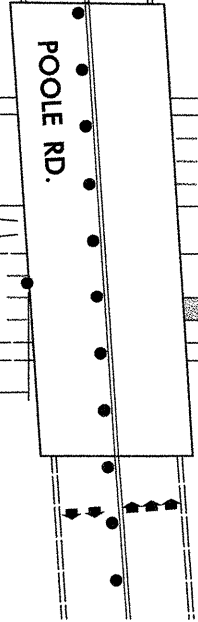

APPROVED: *Michael T. Rzepka* DATE: 3-25-09

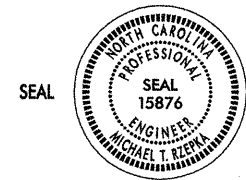

**INNER I-440 LANE 3
 CONST. AT POOLE RD.**

SCALE: NONE
 DATE: MAR 09
 DWG. BY: BLM
 DESIGN BY: GEP
 REVIEWED BY: MTR



NO.	REVISIONS

r:\plans\I5114_fc_top_inner_lane3_poole_wzd.dgn
 3/25/2009 11:20:00 AM

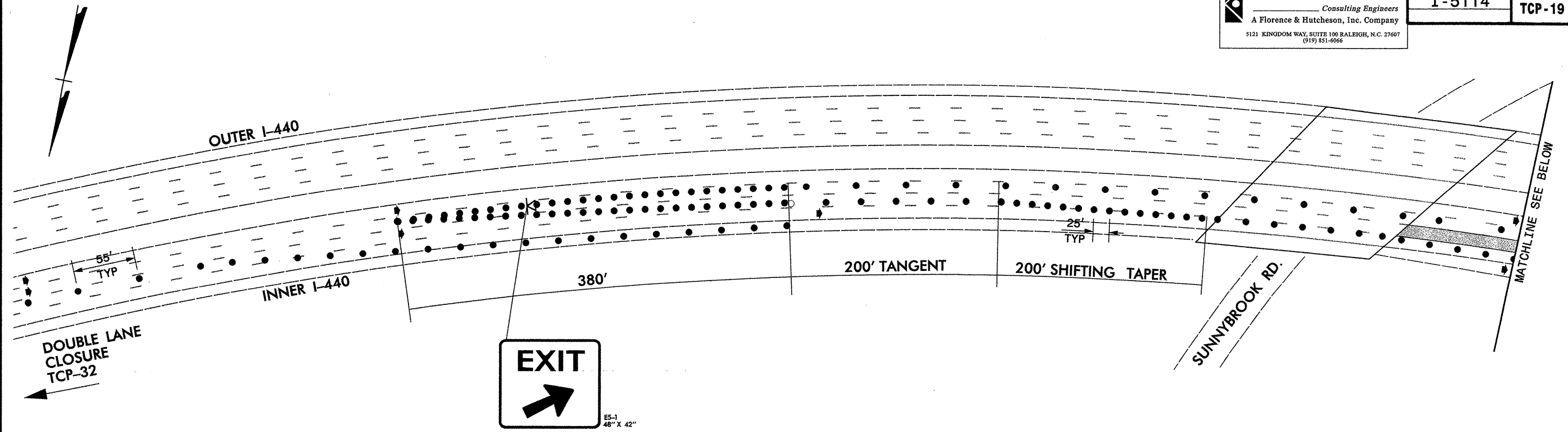

END PROJECT LIMIT

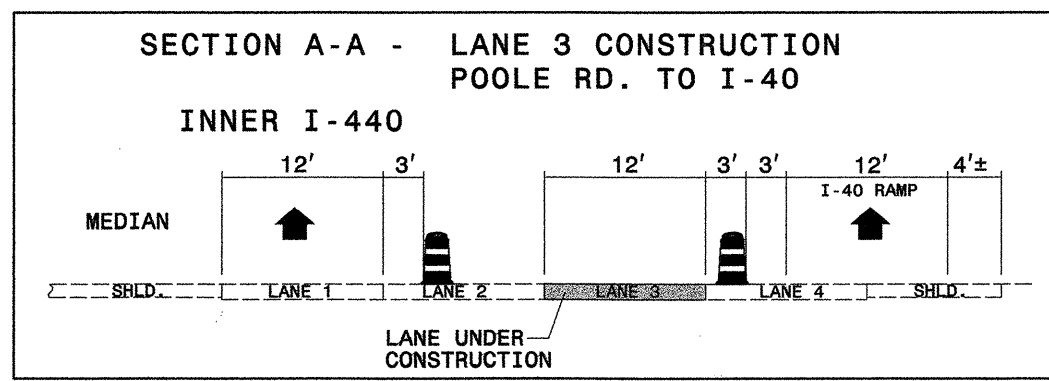
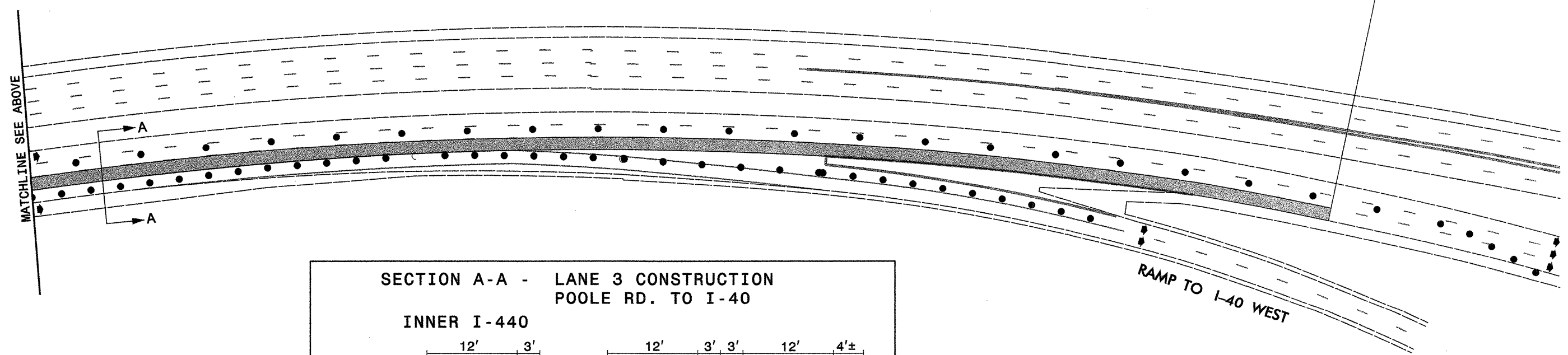

APPROVED: *Michael T. Rippe* DATE: 3-25-09

SEAL

**INNER I-440 LANE 3
 CONST. AT I-40 RAMP**

SCALE: NONE		REVISIONS
DATE: MAR 09		
DWG. BY: BLM		
DESIGN BY: GEP		
REVIEWED BY: MTR		

R:\plans\5114_Tcp_Top_Inner_I440_3_I40_vz.dgn
 3/25/2009 12:48:23 PM

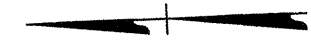

OUTER I-440

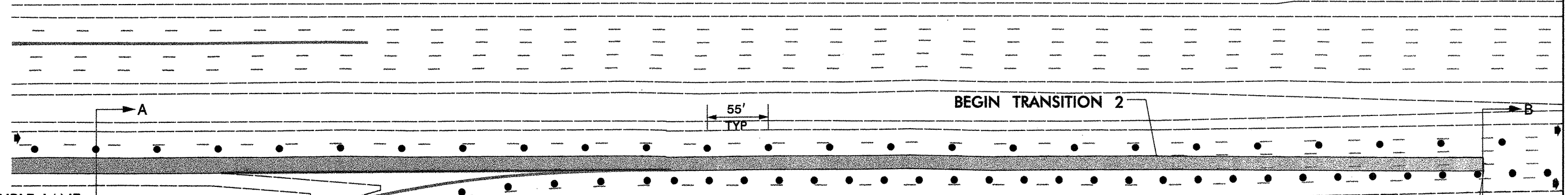

MATCHLINE SEE BELOW

DOUBLE LANE CLOSURE
TCP-32

RSD 1101.02
SHEET 3 OF 9

**SECTION A-A - LANE 3 CONSTRUCTION
 BEGIN LIMIT TO US 64 BYP. RAMP**

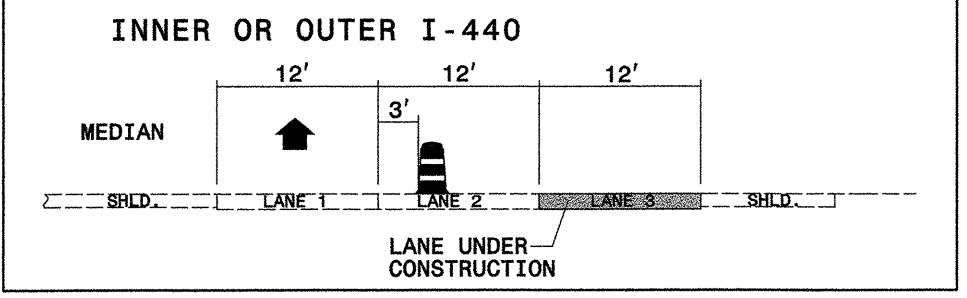

INNER I-440

**SECTION B-B - LANE 3 CONSTRUCTION
 IN TRANSITION AREA**

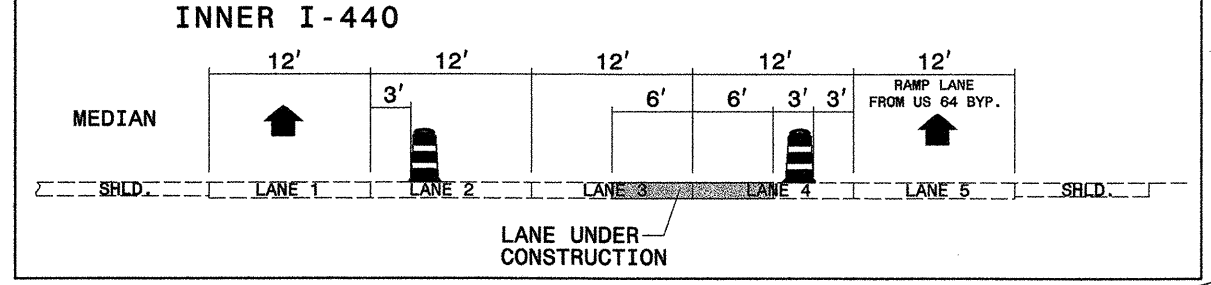

TRANSITION 2
MIDPOINT

RAMP FROM POOLE RD.

MATCHLINE SEE ABOVE

**SECTION C-C - LANE CLOSURE US 64 BYP.
 ENTRANCE RAMP**

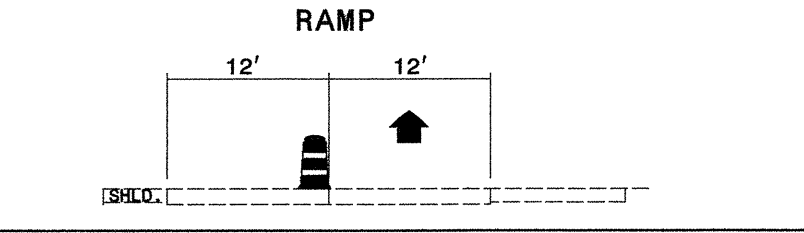

APPROVED: *Michael T. Klepka* DATE: 3-25-09

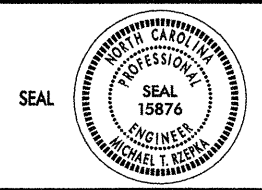

**INNER I-440 LANE 3
 & TRANSITION 2 CONST.
 AT US 64**

SCALE: NONE
 DATE: MAR 09
 DWG. BY: BLM
 DESIGN BY: GEP
 REVIEWED BY: MTR



REVISIONS

R:\plans\5114\I-440_Top_Inner_Lane3_Trans_US64.wzd.dgn
3/25/2009 12:20:44 PM

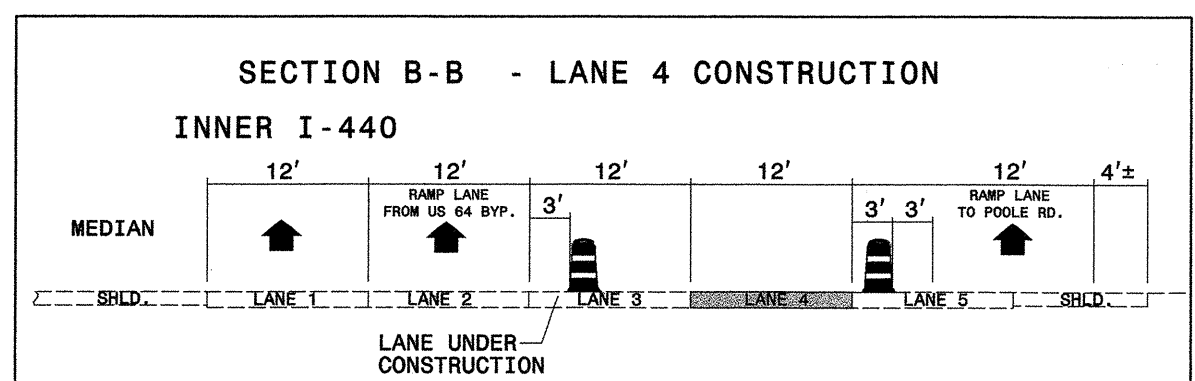
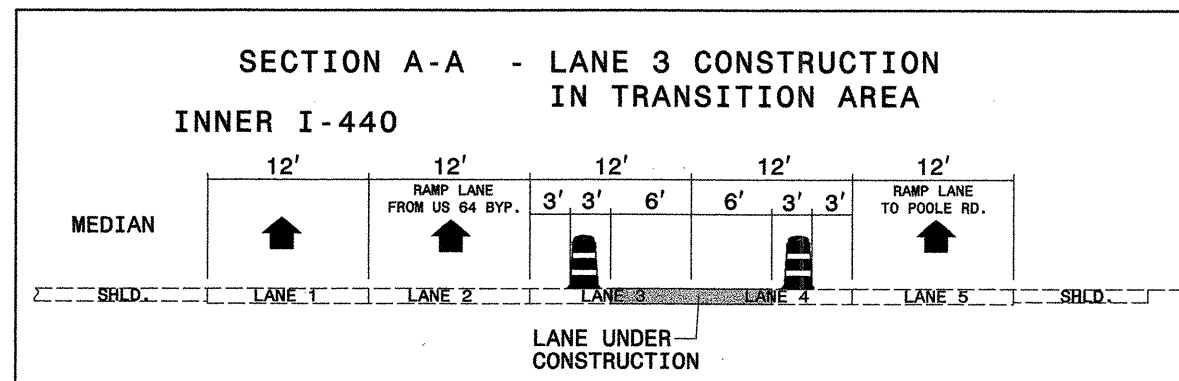
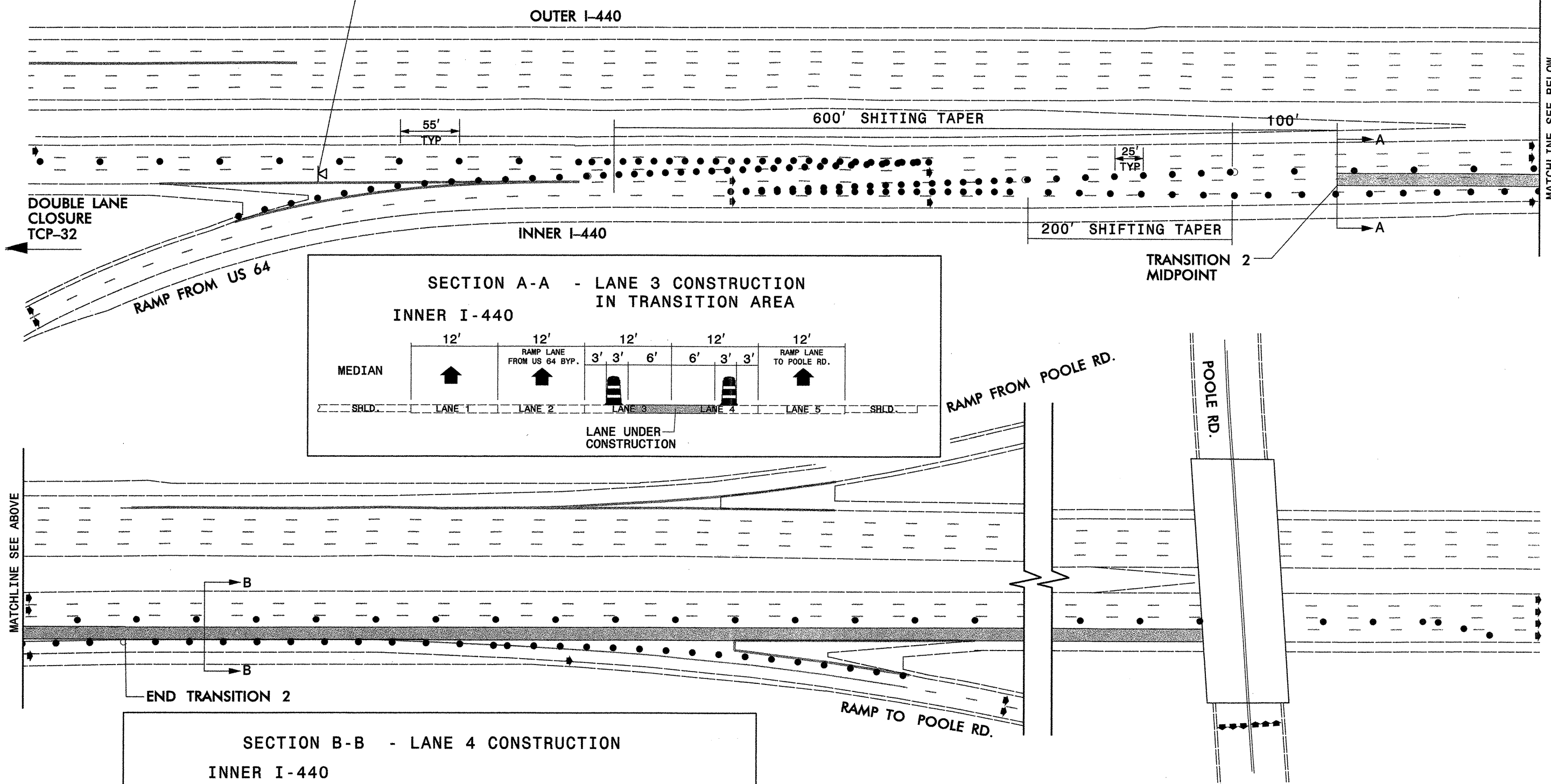
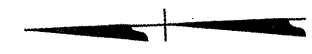
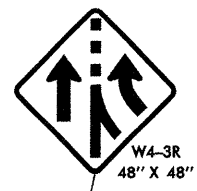

r:\plans\15114_tcp_inner_trans_lane4_us64_wzd.dgn
 3/25/2009 11:20:26 AM

APPROVED: *Michael T. Retina* DATE: 3-25-09

INNER I-440 TRANSITION 2 & LANE 4 CONST. AT US 64

SCALE: NONE		REVISIONS
DATE: MAR 09		
DWG. BY: BLM		
DESIGN BY: GEP		
REVIEWED BY: MTR		

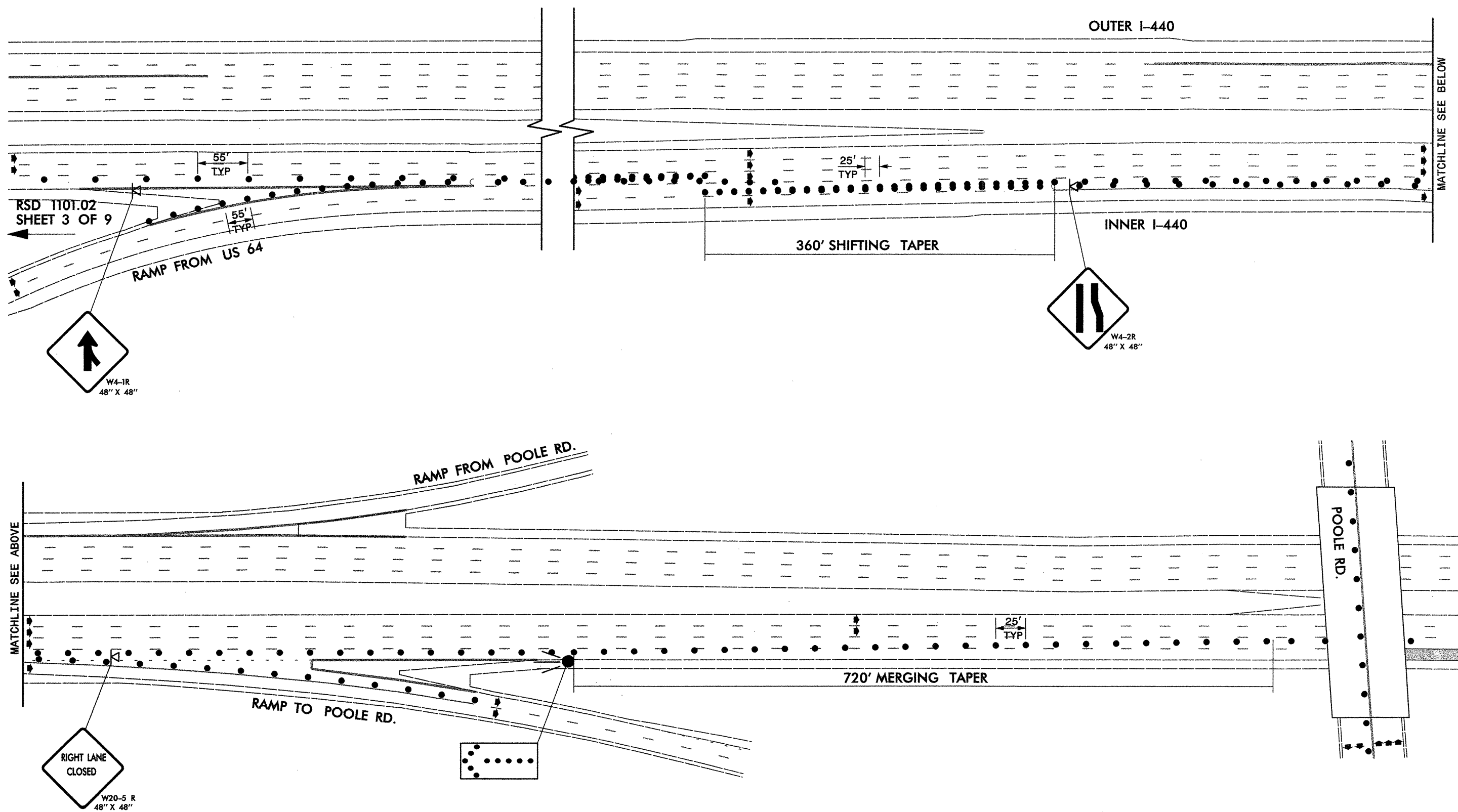
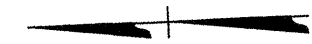

RSD 1101.02
 SHEET 3 OF 9

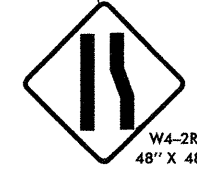

MATCHLINE SEE ABOVE

MATCHLINE SEE BELOW



APPROVED: *Michael T. Riepen* DATE: 3-25-09



**INNER I-440 LANE 4
 CONST. AT POOLE RD.**

SCALE: NONE
 DATE: MAR 09
 DWG. BY: BLM
 DESIGN BY: GEP
 REVIEWED BY: MTR



REVISIONS	

r:\plans\5114_tcp_inner_lane4_poole_vz.dgn
 3/25/2009 11:20:37 AM

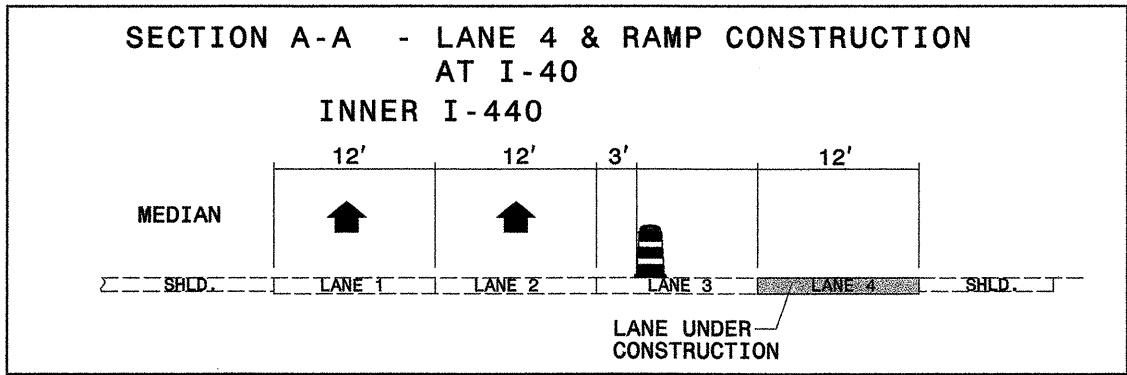
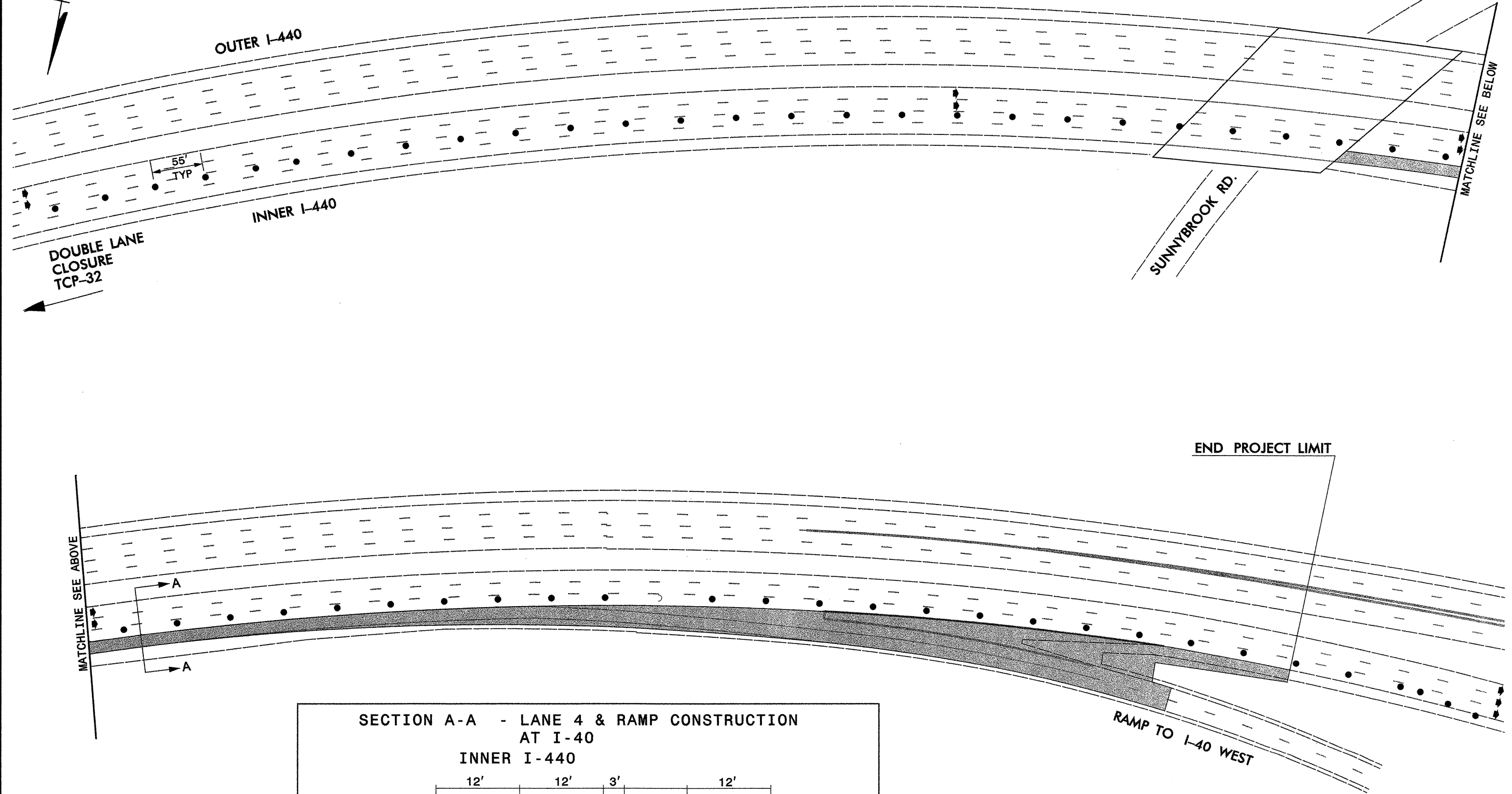

APPROVED: *Michael T. Kierma* DATE: 3-25-09

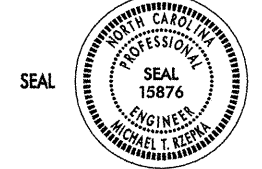

INNER I-440 LANE 4 & RAMP CONST. AT I-40 RAMP

SCALE: NONE
 DATE: MAR 09
 DWG. BY: BLAM
 DESIGN BY: GEP
 REVIEWED BY: MTR



REVISIONS

r:\plans\5114_to_top\inner_lane4_exit_140_wrd.dgn
 3/25/2009 11:20:48 AM

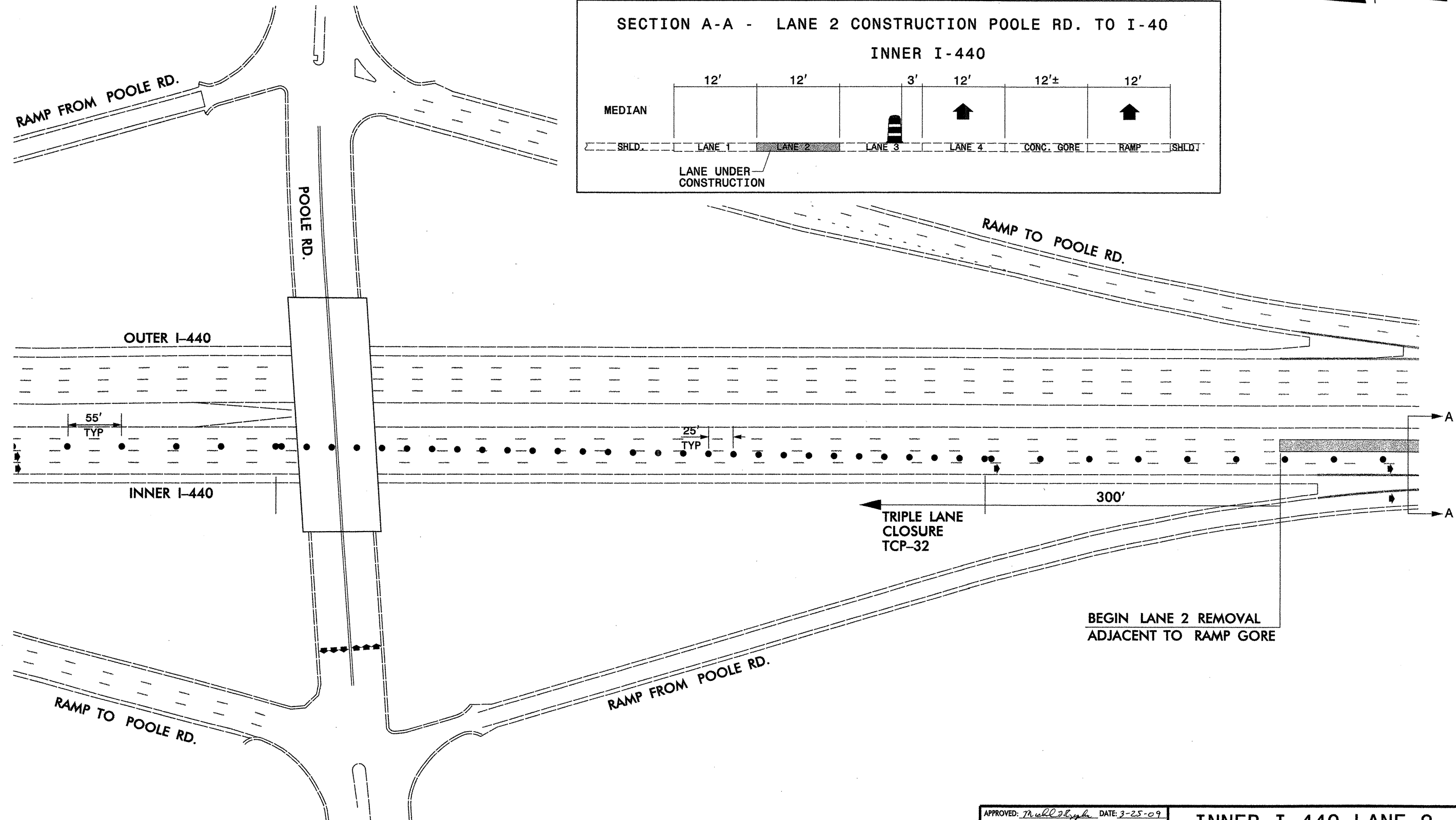
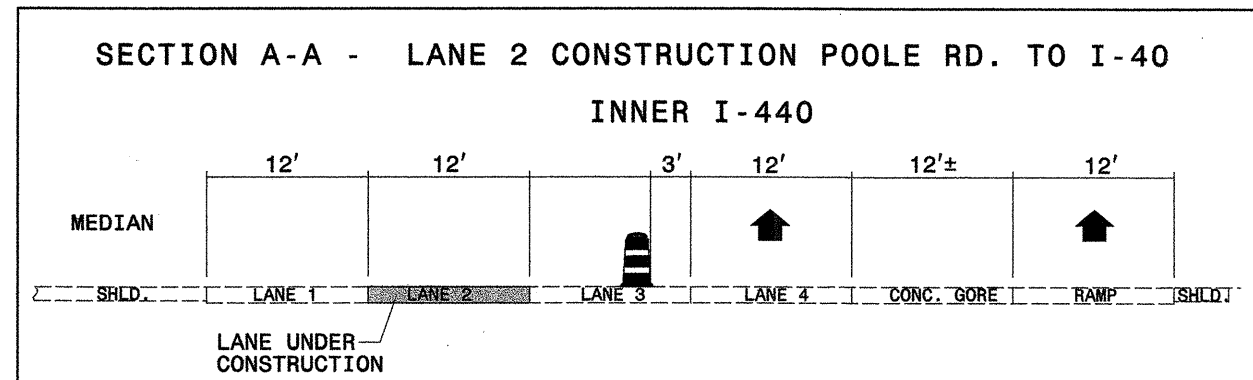
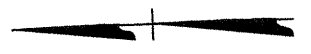

APPROVED: *Michael R. Rieppel* DATE: 3-25-09



**INNER I-440 LANE 2
 CONST. AT POOLE RD.**

SCALE: NONE
 DATE: MAR 09
 DWG. BY: BLM
 DESIGN BY: GEP
 REVIEWED BY: MTR



REVISIONS

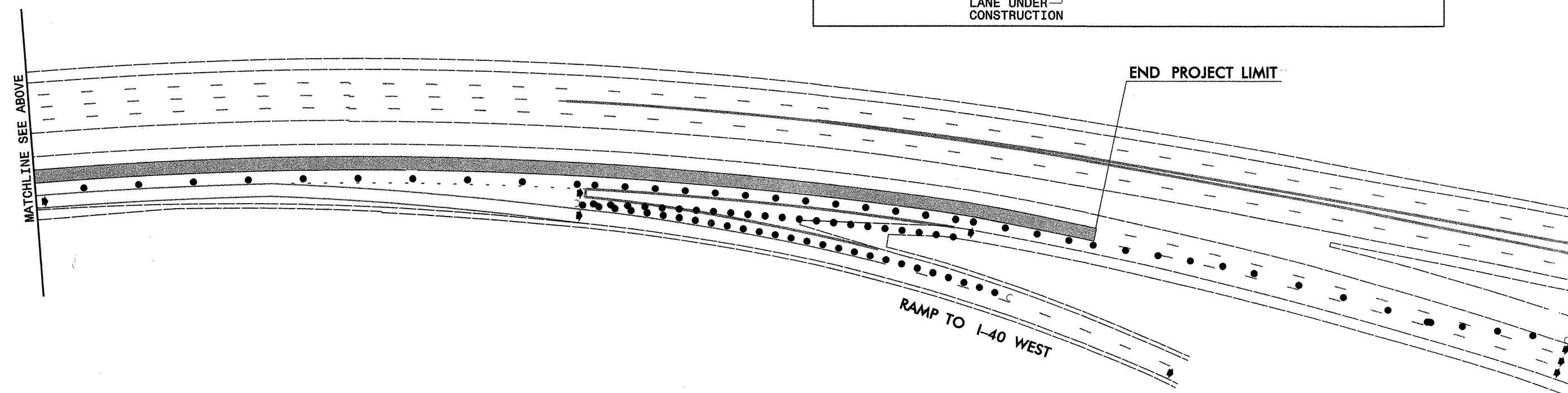
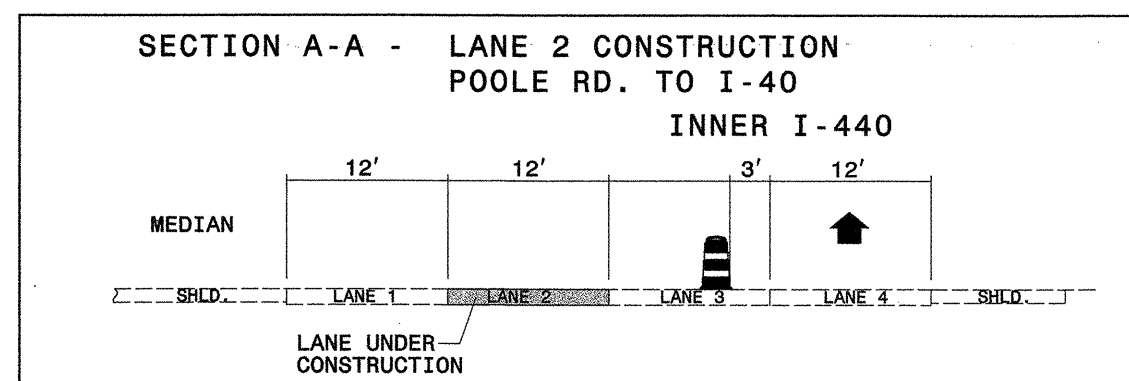
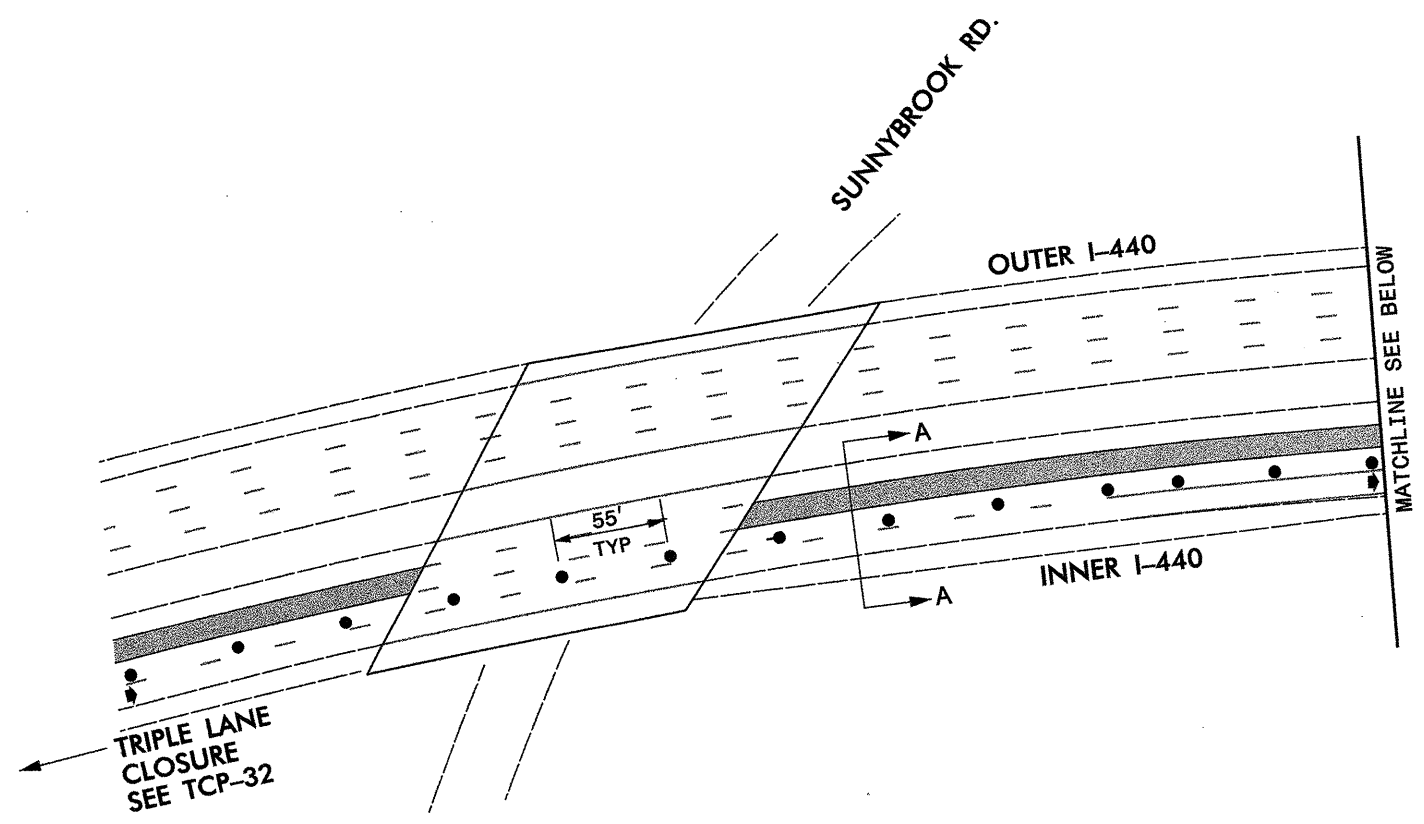

r:\plans\5114_1c_top_inner_lane2_140_wzd.dgn
 3/25/2009 11:21:03 AM

APPROVED: *Michael T. Riepe* DATE: 3-25-09

**INNER I-440 LANE 2
 CONST. AT I-40 RAMP**

SCALE: NONE		REVISIONS
DATE: MAR 09		
DWG. BY: BLM		
DESIGN BY: GEP		
REVIEWED BY: MTR		

KO & ASSOCIATES, P.C.
 Consulting Engineers
 A Florence & Hutcheson, Inc. Company
 5121 KINGDOM WAY, SUITE 100 RALEIGH, N.C. 27607
 (919) 851-6066

PROJ. REFERENCE NO.	SHEET NO.
I-5114	TCP-26

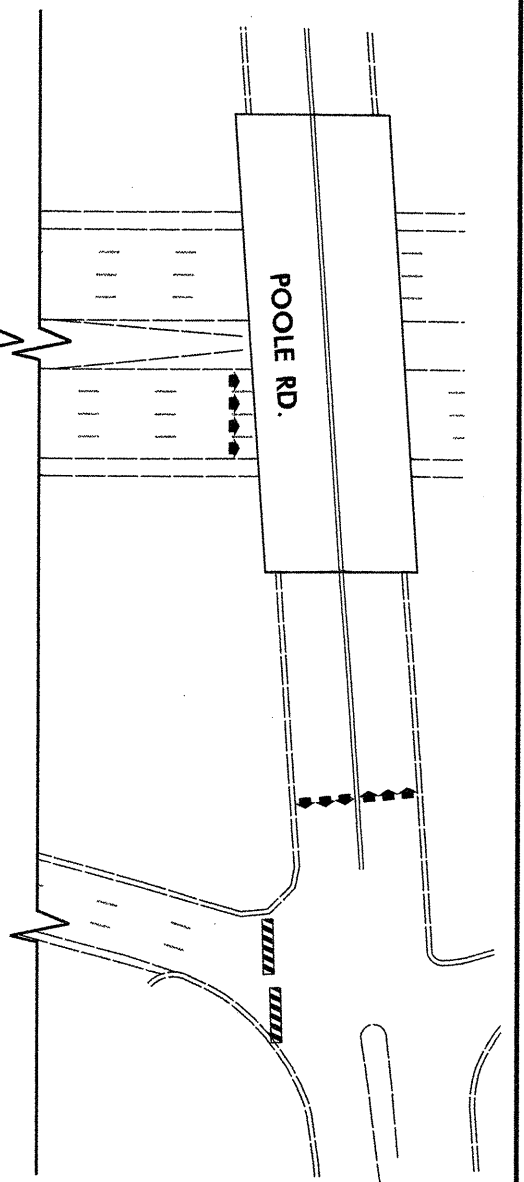
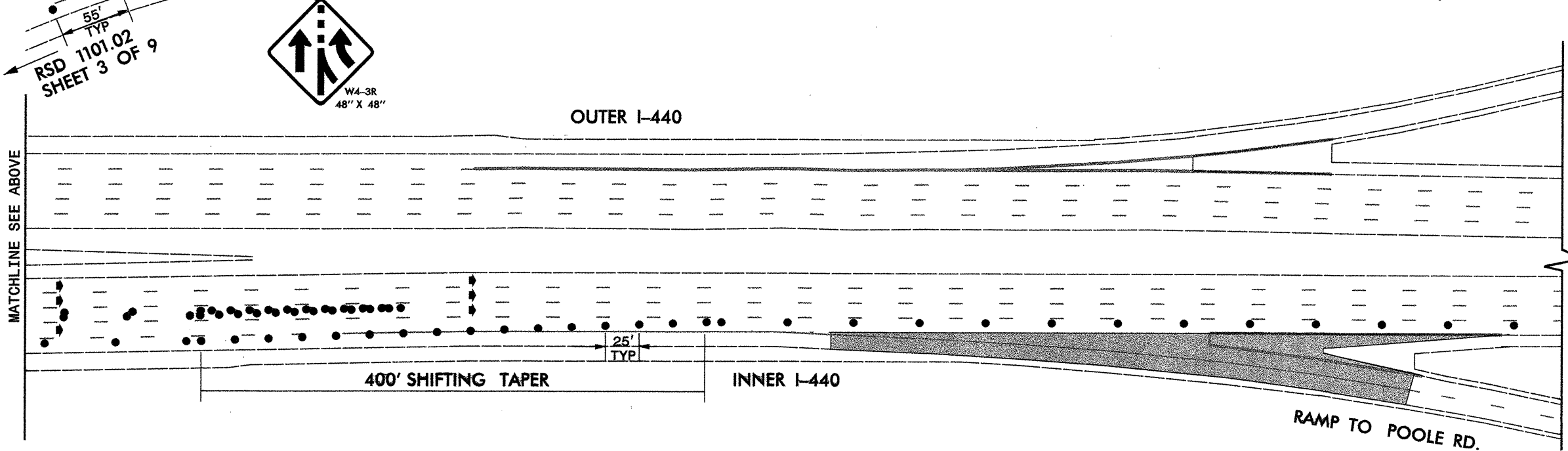
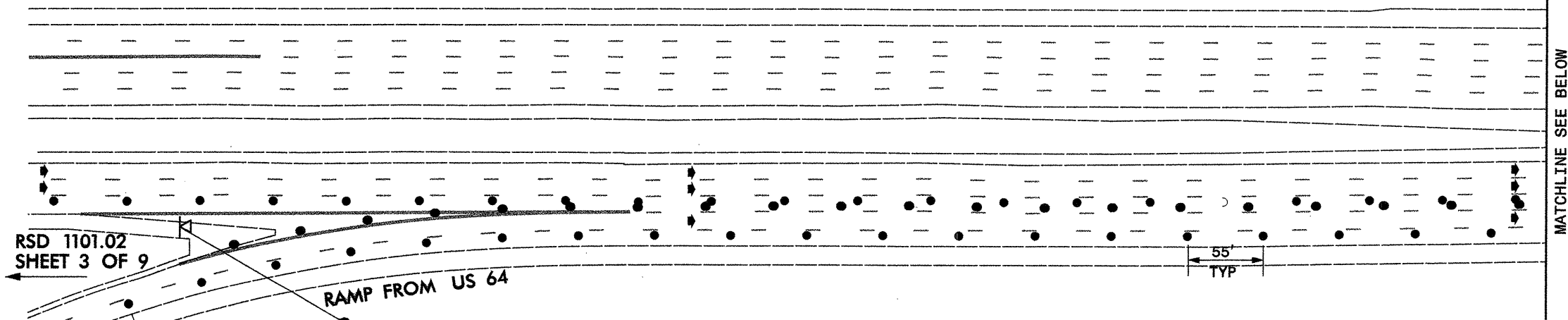
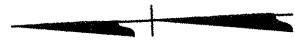

r:\plans\5114\4-16_top_inner_exit_poole_vrzd.dgn
 3/25/2009 11:21:44 AM

APPROVED: *M. R. Rzepka* DATE: 3-25-09

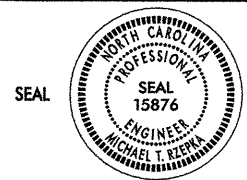

**INNER I-440
 POOLE RD. EXIT RAMP**

SCALE: NONE
 DATE: MAR 09
 DWG. BY: BLM
 DESIGN BY: GEP
 REVIEWED BY: MTR



REVISIONS	

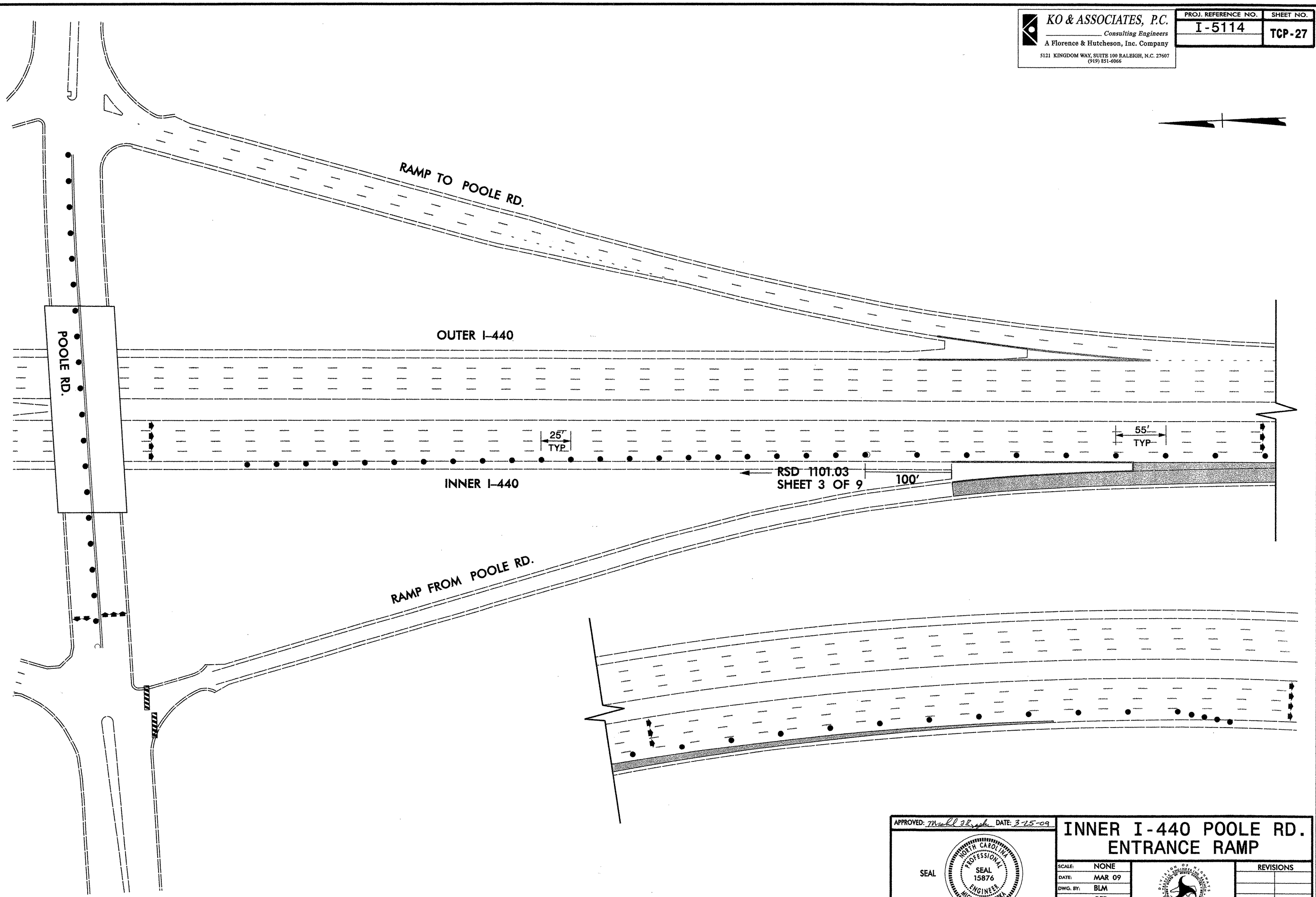
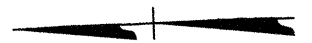

r:\plans\5114_fc_tcp_inner_entrance_poole_wzd.dgn
 3/25/2009 11:21:24 AM

APPROVED: <i>Michael T. Kizema</i> DATE: 3-25-09		INNER I-440 POOLE RD. ENTRANCE RAMP	
SEAL 	SCALE: NONE		
	DATE: MAR 09		
	DWG. BY: BLM		
	DESIGN BY: GEP		
	REVIEWED BY: MTR		

WESTBOUND I-40 RAMP TO OUTER I-440 CLOSED INNER I-440 RAMP TO I-40 EAST CLOSED

KO & ASSOCIATES, P.C.
 Consulting Engineers
 A Florence & Hutcheson, Inc. Company
 5121 KINGDOM WAY, SUITE 100 RALEIGH, N.C. 27607
 (919) 851-6066

PROJ. REFERENCE NO.	SHEET NO.
I-5114	TCP-28

MESSAGE NO. 1	MESSAGE NO. 2
EXIT TO OTR 440 CLOSED	DETOUR USE ROCK QUARRY

CHANGEABLE MESSAGE SIGN

①

MESSAGE NO. 1
OTR 440 USE EXIT 300A

CHANGEABLE MESSAGE SIGN

②

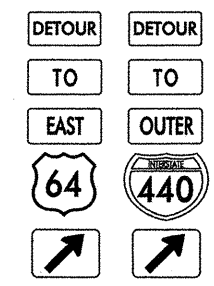

Ⓐ

MESSAGE NO. 1	MESSAGE NO. 2
EXIT TO I-40E CLOSED	DETOUR USE ROCK QUARRY

CHANGEABLE MESSAGE SIGN

③

MESSAGE NO. 1
I-40E USE EXIT 300A

CHANGEABLE MESSAGE SIGN

④

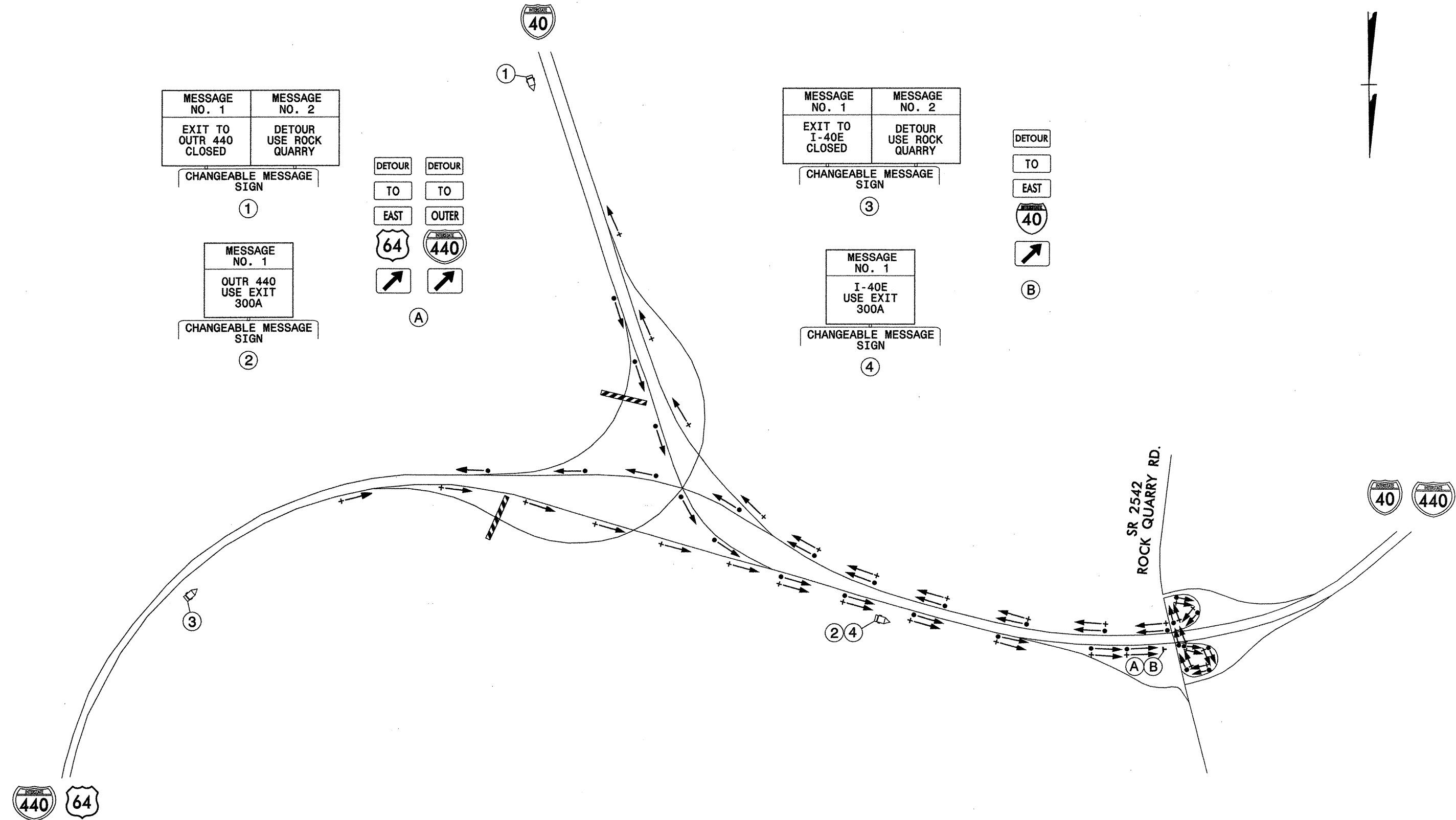

LEGEND

- DETOUR ROUTE FOR WHEN WESTBOUND I-40 EXIT RAMP AT OUTER I-440 IS CLOSED
- - - → DETOUR ROUTE FOR WHEN INNER I-440 EXIT RAMP AT EASTBOUND I-40 IS CLOSED

APPROVED: *Michael J. Rzepka* DATE: 3-25-09



I-40 RAMP DETOURS

SCALE: NONE
 DATE: MAR 09
 DWG. BY: BLM
 DESIGN BY: GEP
 REVIEWED BY: MTR



REVISIONS	

R:\plans\I-440_to_trap_detour_ldgn
 3/25/2009 12:41:32 PM

INNER I-440 EXIT RAMP AT POOLE RD. CLOSED OUTER I-440 ENTRANCE RAMP AT POOLE RD. CLOSED

KO & ASSOCIATES, P.C.
 Consulting Engineers
 A Florence & Hutcheson, Inc. Company
 5121 KINGDOM WAY, SUITE 100 RALEIGH, N.C. 27607
 (919) 851-6066

PROJ. REFERENCE NO.	SHEET NO.
I-5114	TCP-29

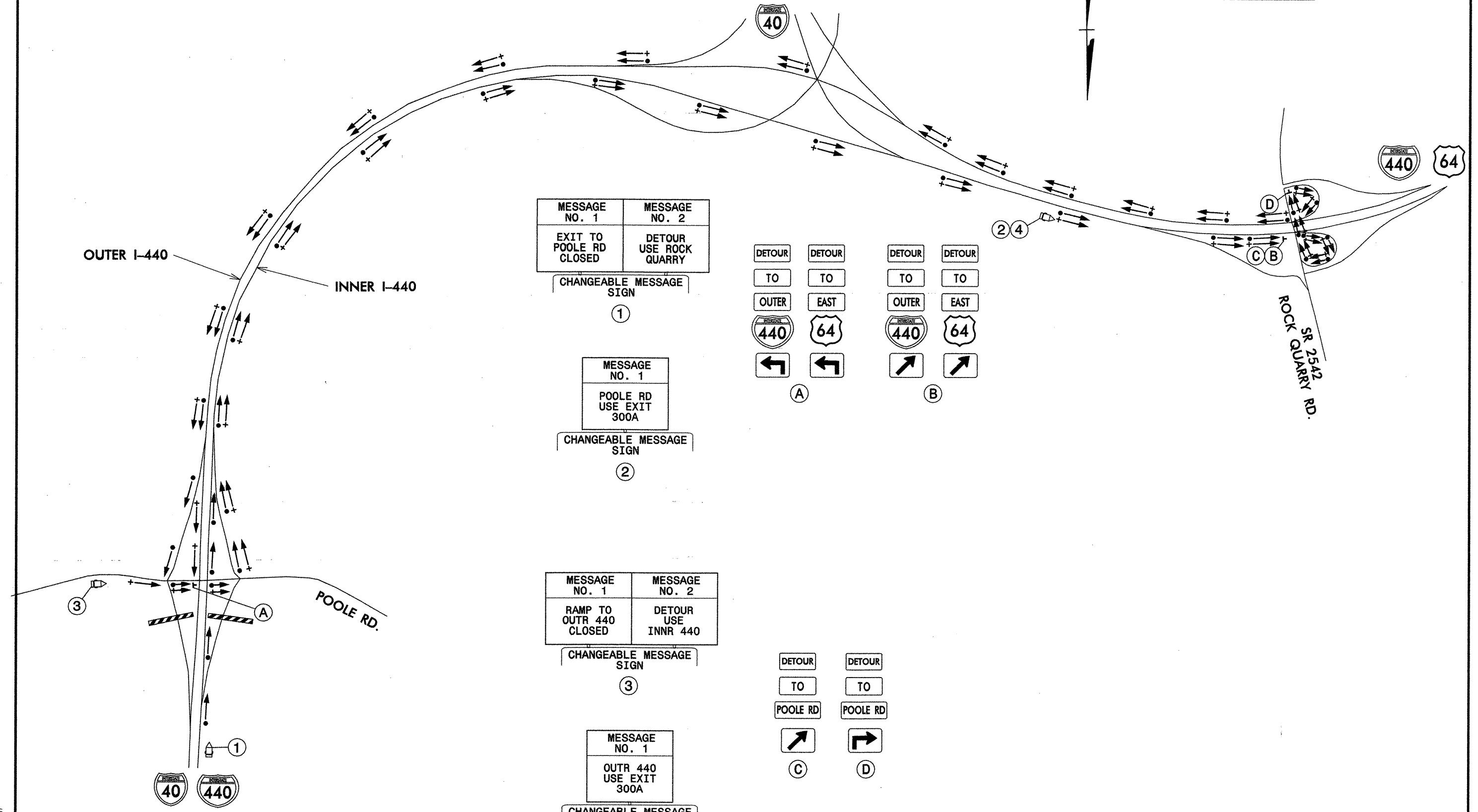

MESSAGE NO. 1	MESSAGE NO. 2
EXIT TO POOLE RD CLOSED	DETOUR USE ROCK QUARRY

CHANGEABLE MESSAGE SIGN
 ①

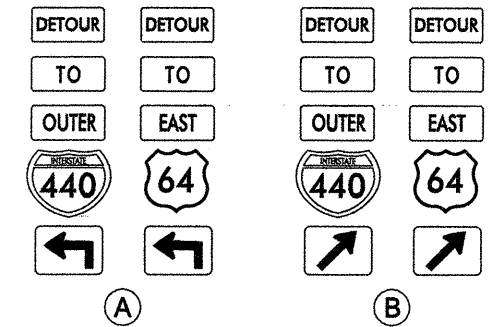

MESSAGE NO. 1
POOLE RD USE EXIT 300A

CHANGEABLE MESSAGE SIGN
 ②

MESSAGE NO. 1	MESSAGE NO. 2
RAMP TO OTR 440 CLOSED	DETOUR USE INNER 440

CHANGEABLE MESSAGE SIGN
 ③

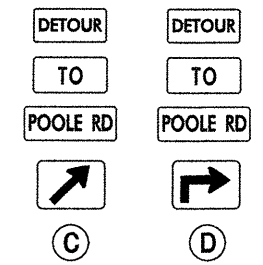

MESSAGE NO. 1
OUTR 440 USE EXIT 300A

CHANGEABLE MESSAGE SIGN
 ④

LEGEND

- DETOUR ROUTE FOR WHEN INNER I-440 EXIT RAMP AT POOLE RD. IS CLOSED
- DETOUR ROUTE FOR WHEN OUTER I-440 ENTRANCE RAMP AT POOLE RD. IS CLOSED

APPROVED: *Michael T. Riepla* DATE: 3-25-09

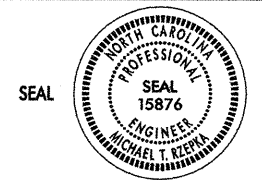

POOLE RD. RAMP DETOURS (NORTH SIDE)

SCALE: NONE
 DATE: MAR 09
 DWG. BY: BLM
 DESIGN BY: CEP
 REVIEWED BY: MTR



REVISIONS	

R:\plans\440\to_top_detour_2.dgn
 3/25/2009 12:40:56 PM

OUTER I-440 EXIT RAMP AT POOLE RD. CLOSED INNER I-440 ENTRANCE RAMP AT POOLE RD. CLOSED

KO & ASSOCIATES, P.C.
 Consulting Engineers
 A Florence & Hutcheson, Inc. Company
 5121 KINGDOM WAY, SUITE 100 RALEIGH, N.C. 27607
 (919) 851-6066

PROJ. REFERENCE NO. I-5114	SHEET NO. TCP-30
--------------------------------------	----------------------------

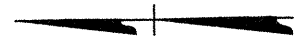

MESSAGE NO. 1	MESSAGE NO. 2
EXIT TO POOLE RD CLOSED	DETOUR USE NEW BERN

CHANGEABLE MESSAGE SIGN

①

MESSAGE NO. 1
POOLE RD USE EXIT 13A

CHANGEABLE MESSAGE SIGN

②

DETOUR DETOUR

TO TO

POOLE RD POOLE RD



Ⓐ



Ⓑ

64 264

OUTER I-440

INNER I-440

POOLE RD.

440
64

MESSAGE NO. 1	MESSAGE NO. 2
RAMP TO INNR 440 CLOSED	DETOUR USE OTR 440

CHANGEABLE MESSAGE SIGN

③

MESSAGE NO. 1
INNR 440 USE EXIT 13A

CHANGEABLE MESSAGE SIGN

④

DETOUR DETOUR DETOUR DETOUR

TO TO TO TO

INNER WEST INNER WEST



Ⓒ



Ⓓ

LEGEND

- ➔ DETOUR ROUTE FOR WHEN OUTER I-440 EXIT RAMP AT POOLE RD. IS CLOSED
- ➔ DETOUR ROUTE FOR WHEN INNER I-440 ENTRANCE RAMP AT POOLE RD. IS CLOSED

APPROVED: *Michael T. Rzepka* DATE: 3-25-09

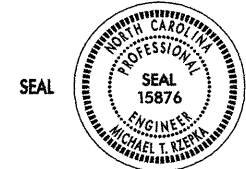

POOLE RD. RAMP DETOURS (SOUTH SIDE)

SCALE: NONE		REVISIONS
DATE: MAR 09		
DWG. BY: BLM		
DESIGN BY: GEP		
REVIEWED BY: MTR		

R:\plans\I-440_Tc_top_detour_3.dgn 3/25/2009 12:38:05 PM

ADVANCED WORK ZONE WARNING SIGNING FOR FREEWAYS (4 LANES OR GREATER)

KO & ASSOCIATES, P.C.
 Consulting Engineers
 A Florence & Hutcheson, Inc. Company
 5121 KINGDOM WAY, SUITE 100 RALEIGH, N.C. 27607
 (919) 851-6066

PROJ. REFERENCE NO.	SHEET NO.
I-5114	TCP-31

DETAIL A

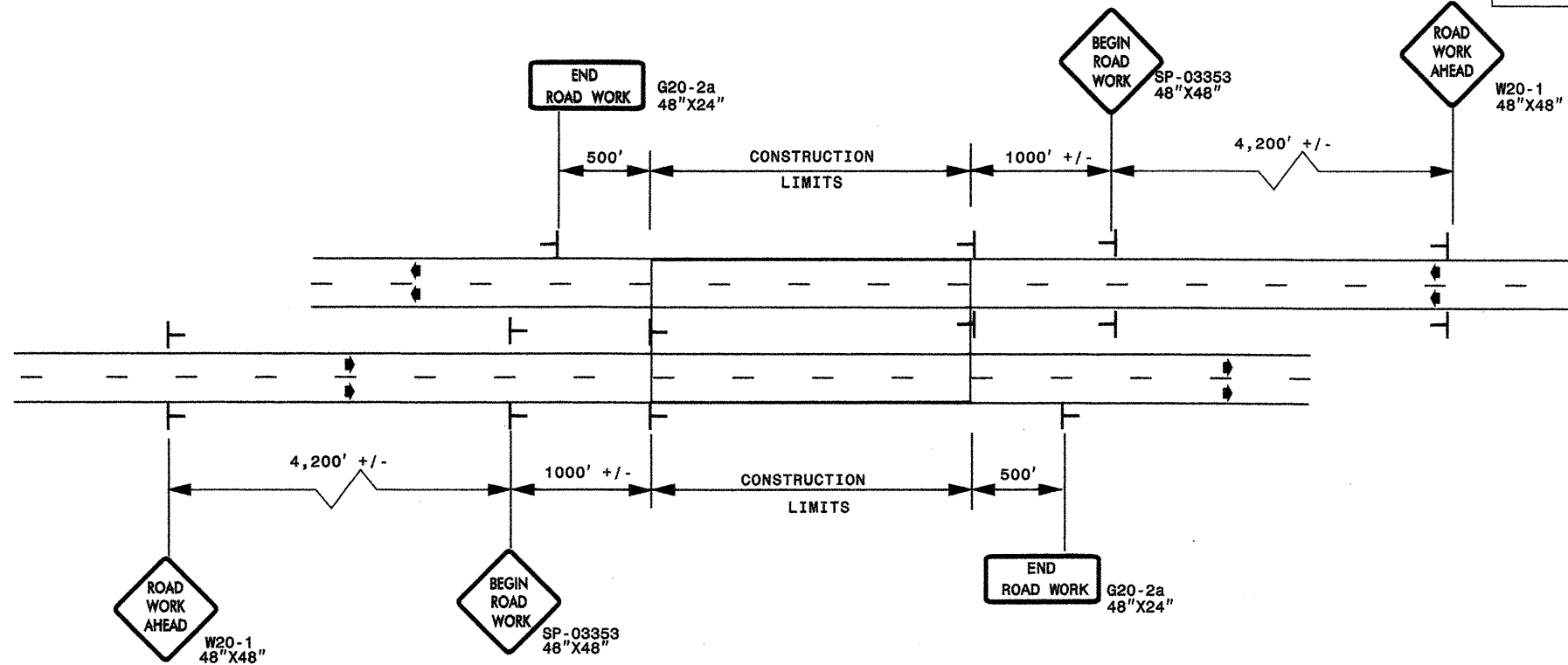

LEGEND	
—	STATIONARY SIGN
◆	DIRECTION OF TRAFFIC FLOW

DETAIL B

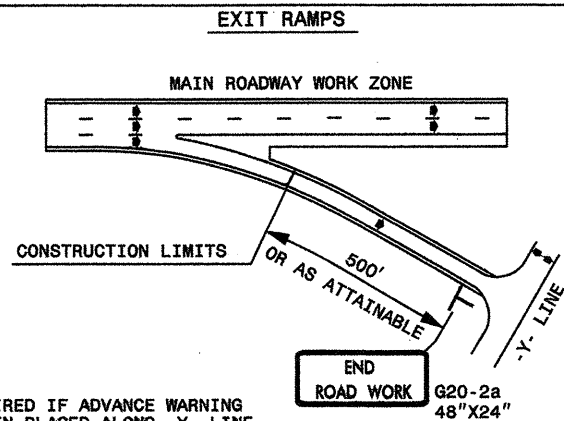

NOTE: SIGN NOT REQUIRED IF ADVANCE WARNING SIGNS HAVE BEEN PLACED ALONG -Y- LINE THAT RAMP INTERSECTS. IF CONSTRUCTION LIMITS ARE AT END OF RAMP, PLACE SIGN AT END OF RAMP.

DETAIL C

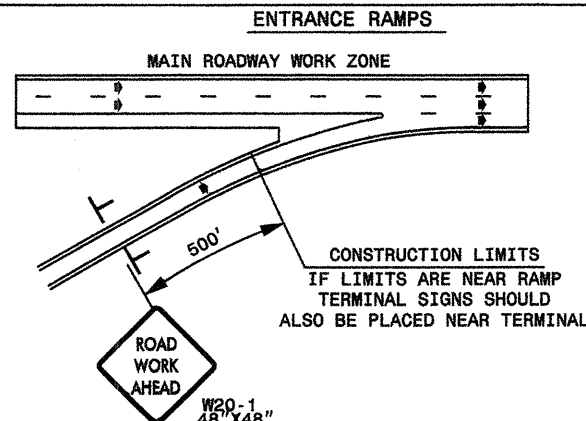

CONSTRUCTION LIMITS IF LIMITS ARE NEAR RAMP TERMINAL SIGNS SHOULD ALSO BE PLACED NEAR TERMINAL

DETAIL D

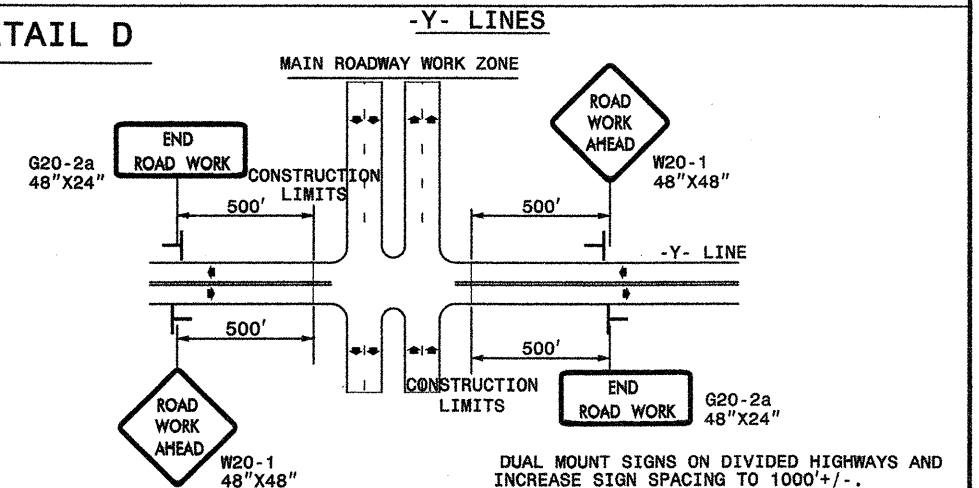

DUAL MOUNT SIGNS ON DIVIDED HIGHWAYS AND INCREASE SIGN SPACING TO 1000'+/-.

GENERAL NOTES

- USE FLUORESCENT ORANGE SHEETING (TYPE VII OR HIGHER) ON ALL ADVANCED WORK ZONE SIGNS.
- DO NOT INSTALL ADVANCE WARNING SIGNS MORE THAN 3 DAYS PRIOR TO BEGINNING OF WORK.
- SIGNS SHOWN ARE REQUIRED FOR WORK ZONES THAT WILL REMAIN IN EFFECT OVERNIGHT. FOR SHORT-TERM DAILY MAINTENANCE TYPE OPERATIONS, THIS SIGNING APPLICATION IS OPTIONAL; MAY USE ONLY APPLICABLE ROADWAY STANDARD DRAWINGS INSTEAD. HOWEVER, IF THIS SIGNING APPLICATION IS USED, SIGNS MAY BE PORTABLE MOUNTED.
- ALL SIGN SPACING DIMENSIONS ARE APPROXIMATE, FIELD ADJUST AS NECESSARY OR AS DIRECTED.
- USE 3LB STEEL U-CHANNEL POST OR 4" X 4" WOOD POST FOR ALL WORK ZONE SIGNS. 3LB STEEL U-CHANNEL POSTS MUST MEET THE REQUIREMENTS OF STANDARD SPECIFICATION SECTION 1094-1(B). MAY BE GALVANIZED STEEL, OR MAY BE PAINTED GREEN BY THE POST MANUFACTURER. SQUARE STEEL TUBING POSTS HAVING EQUIVALENT STRENGTH OF THE 3 LB STEEL U-CHANNEL POST ARE ALSO ACCEPTABLE FOR USE. ERECT SIGNS PER ROADWAY STANDARD DRAWING 1110.01. PAYMENT FOR WOOD POSTS, 3LB STEEL U-CHANNEL AND SQUARE STEEL TUBING POSTS WITH SIGNS WILL BE MADE ACCORDING TO STANDARD SPECIFICATION "WORK ZONE SIGNS" SECTION 1110.
- WHEN NECESSARY, USE SPLICING IN ACCORDANCE WITH ROADWAY STANDARD DRAWING NO. 1110.01. REMOVE ENTIRE POST WHEN REMOVING SIGNS WITH SPLICED POSTS.
- DO NOT BACK BRACE SIGN SUPPORTS.

APPROVED: <i>Michael T. Kepp</i> DATE: 3-25-09	ADVANCED WORK ZONE WARNING SIGNS FOR FREEWAYS (4 LANES OR GREATER)									
	SCALE: NONE	<table border="1"> <tr> <th colspan="2">REVISIONS</th> </tr> <tr> <td> </td> <td> </td> </tr> <tr> <td> </td> <td> </td> </tr> <tr> <td> </td> <td> </td> </tr> </table>	REVISIONS							
	REVISIONS									
DATE: MAR 09										
DWG. BY: BLM										
DESIGN BY: GEP										
REVIEWED BY: MTR	<table border="1"> <tr> <td>CAD</td> <td> </td> </tr> <tr> <td>FILE</td> <td> </td> </tr> </table>	CAD		FILE						
CAD										
FILE										

CLOSURE OF RIGHT THREE LANES

KO & ASSOCIATES, P.C.
 Consulting Engineers
 A Florence & Hutcheson, Inc. Company
 5121 KINGDOM WAY, SUITE 100 RALEIGH, N.C. 27607
 (919) 851-0066

PROJ. REFERENCE NO. I-5114
 SHEET NO. TCP-32

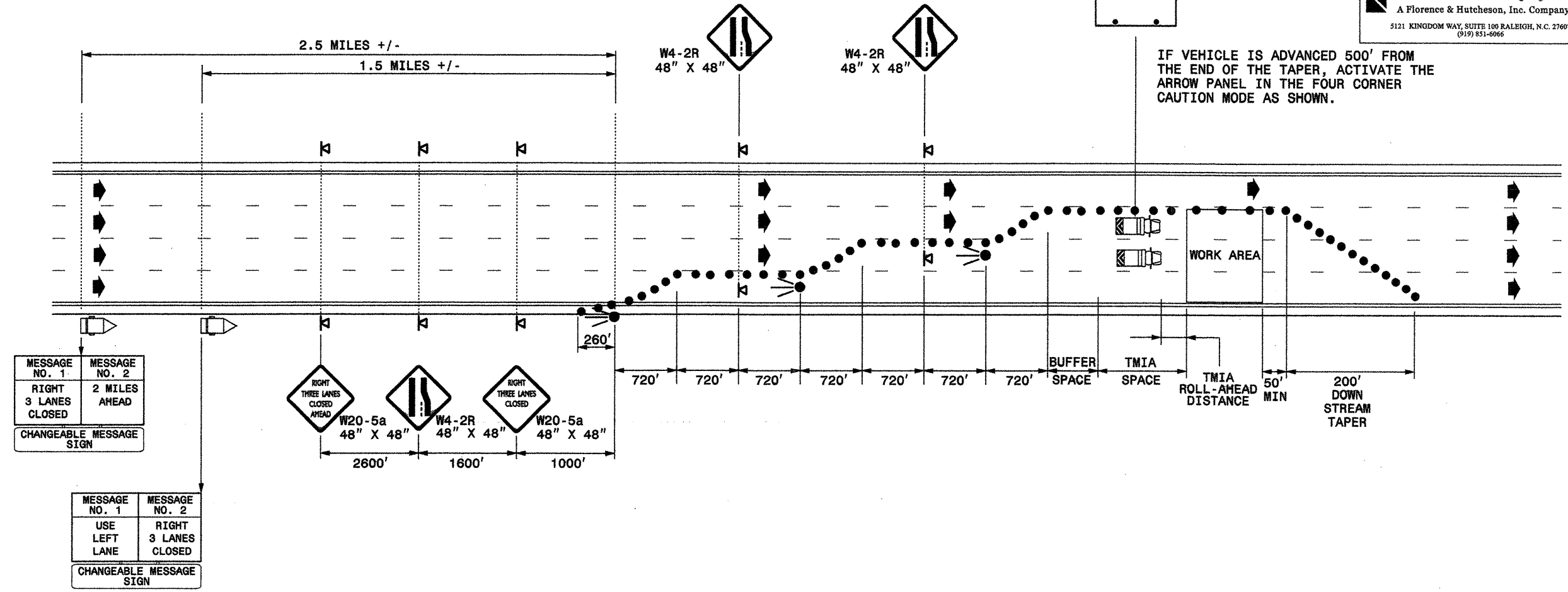

CLOSURE OF RIGHT TWO LANES

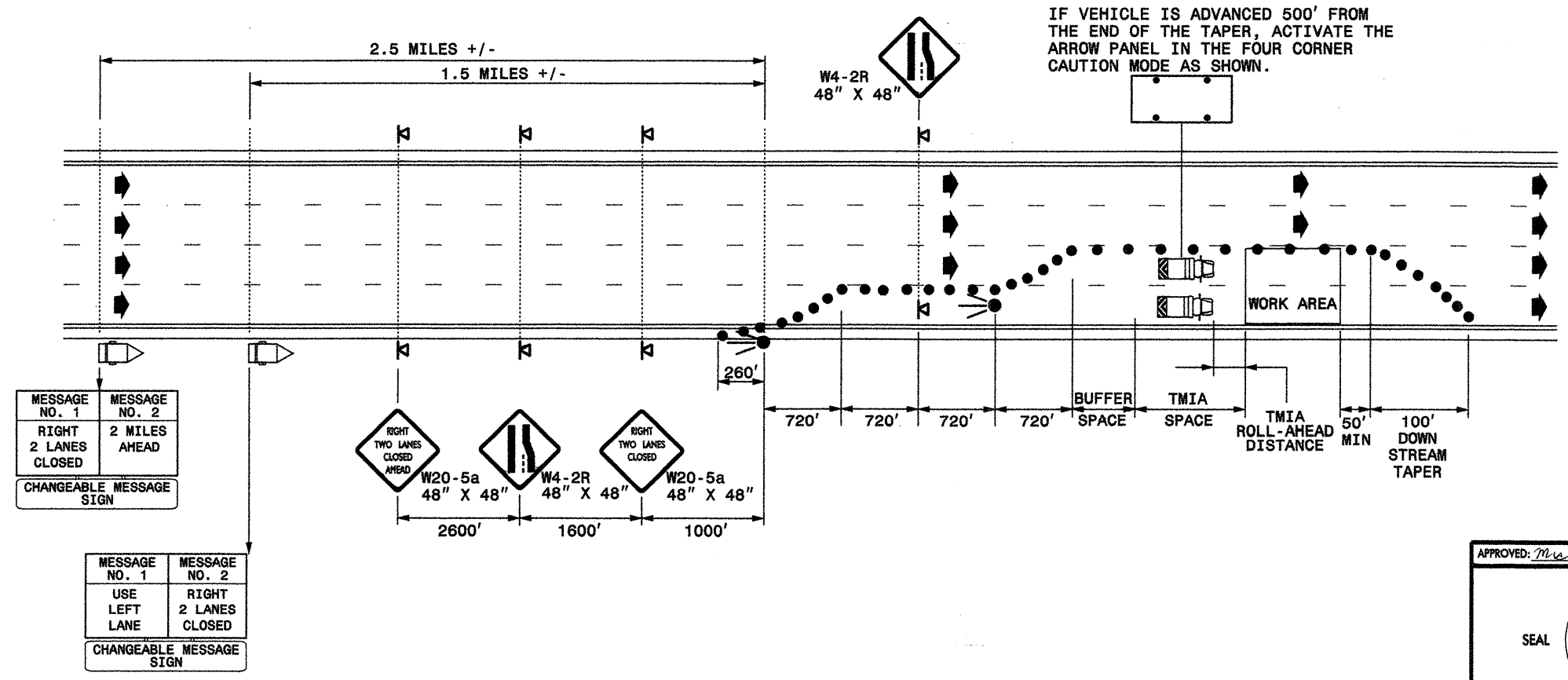

GENERAL NOTES

- 1-Refer to Notes on Rdwy Std 1101.02 Sheet 3 of 9.
- 2-Coordinate use of overhead DMSs with the Division.
- 3-Use following configuration for FAP (Flashing Arrow Panel)
- 4-Symbols shown are for Right Lane Closure. Use appropriate signs, messages and arrows for Left Lane Closure. Portable CMSs to remain positioned as shown.

APPROVED: *Michael T. Rzepka* DATE: 3-25-09

INTERSTATE DUAL/TRIPLE LANE CLOSURE

SCALE: NONE
 DATE: MAR 09
 DWG. BY: BLM
 DESIGN BY: GEP
 REVIEWED BY: MTR

SEAL

REVISIONS

STATE OF NORTH CAROLINA
 DEPT. OF TRANSPORTATION
 DIVISION OF HIGHWAYS
 RALEIGH, N.C.

5-07

ENGLISH DETAIL DRAWING FOR
INDUCTIVE DETECTION LOOPS

SHEET 1 OF 3
1725D01

SAW SLOT DEPTH CHART

DEPTH (IN)	NO. OF WIRE TURNS				
	2	3	4	5	6
CONCRETE	2.0	2.0	2.5	2.5	3.0
ASPHALT	2.0	2.5	3.0	3.0	3.0

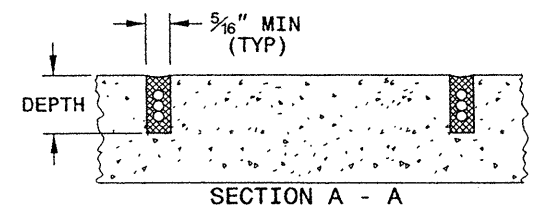

CONVENTIONAL 4-SIDED LOOP

SAW CUT OPTIONS

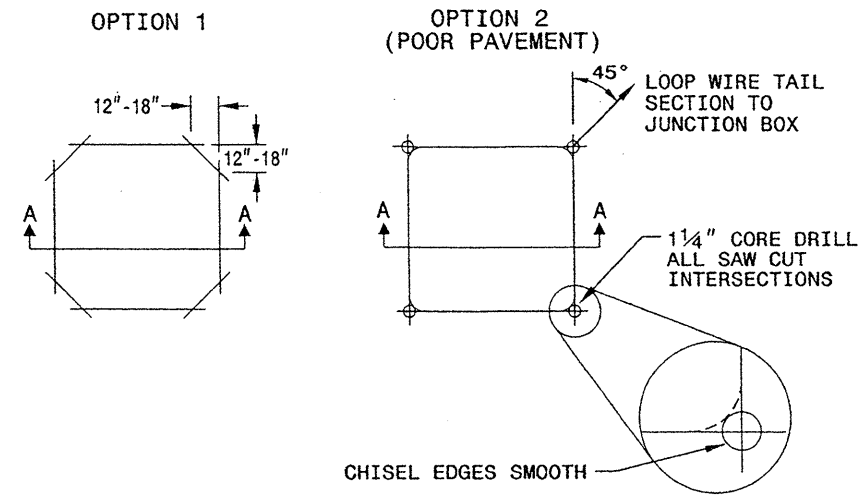

LOOP WINDING METHOD

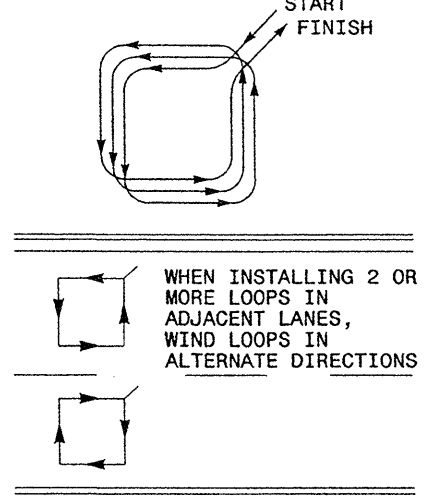

LOOP WIRE TWISTING METHOD

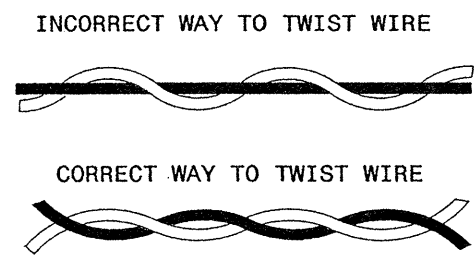

NOTES

- OVERLAP SAW CUTS AT CORNERS AND INTERSECTION POINTS TO ENSURE UNIFORM SAW SLOT DEPTH.
- MAINTAIN 12" SPACING BETWEEN LOOP WIRE TAIL SECTIONS.
- WIRE LOOPS CONNECTED TO THE SAME DETECTOR CHANNEL IN SERIES.
- LOCATE LOOPS IN CENTER OF LANES UNLESS OTHERWISE SHOWN ON PLANS OR APPROVED BY ENGINEER.

QUADRUPOLE LOOP

SAW CUT OPTIONS

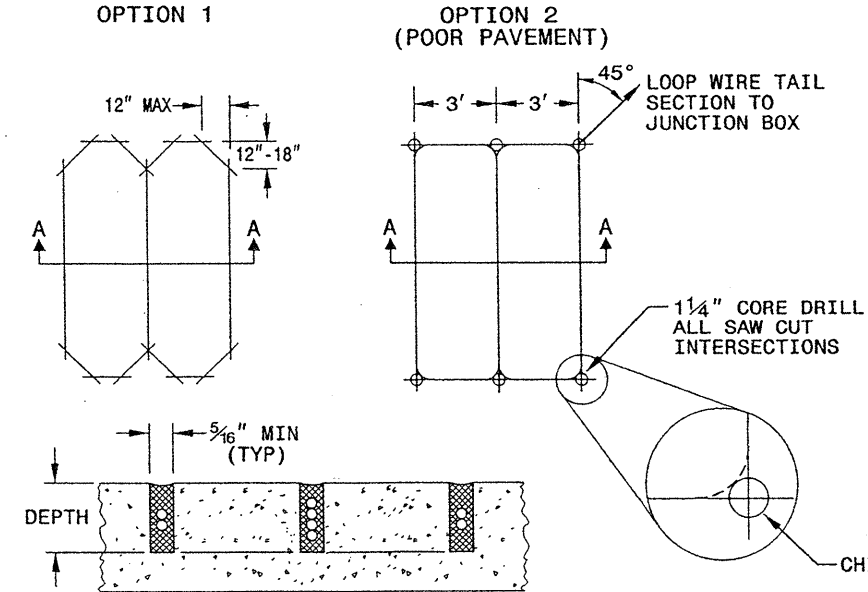

LOOP WINDING METHOD

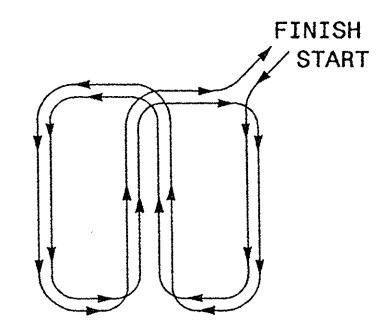

DEPTH IS 2.5" FOR CONCRETE AND 3.0" FOR ASPHALT

STATE OF NORTH CAROLINA
 DEPT. OF TRANSPORTATION
 DIVISION OF HIGHWAYS
 RALEIGH, N.C.

5-07

ENGLISH DETAIL DRAWING FOR
INDUCTIVE DETECTION LOOPS

SHEET 1 OF 3
1725D01

See Plate for Title

Prepared in the Offices of:

750 N. Greenfield Parkway
 Garner, NC 27529

SEAL

Milton I. Deann 9/5/07
 SIGNATURE DATE

05-SEP-2007 14:00 c:\documents and settings\jgarezi\1111e.d01\res\dstp\standard\metrol\pols sheets\1725D01.dwg 2/301.dgn

STATE OF NORTH CAROLINA
DEPT. OF TRANSPORTATION
DIVISION OF HIGHWAYS
RALEIGH, N.C.

5-07

ENGLISH DETAIL DRAWING FOR
INDUCTIVE DETECTION LOOPS
LOOP WIRE DETAILS

SHEET 2 OF 3
1725D01

LOOP WIRE SPLICE POINT DETAILS

LOOP WIRE AT JUNCTION BOX

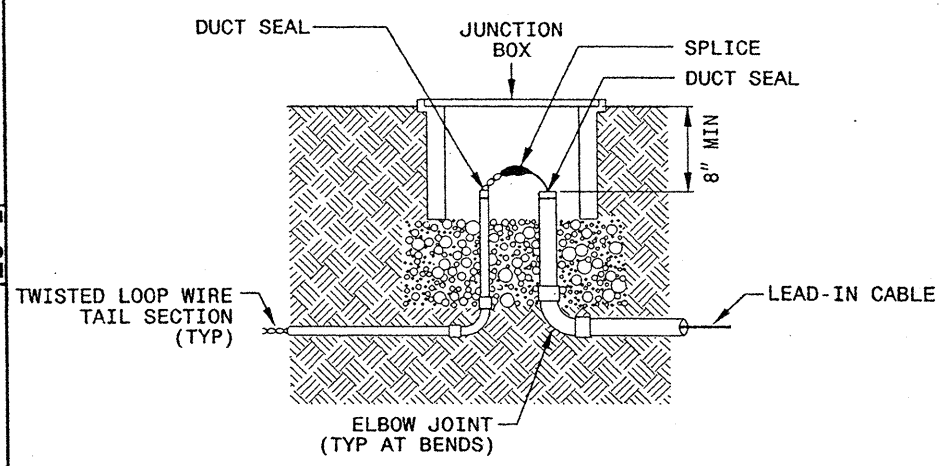

LOOP WIRE AT POLE

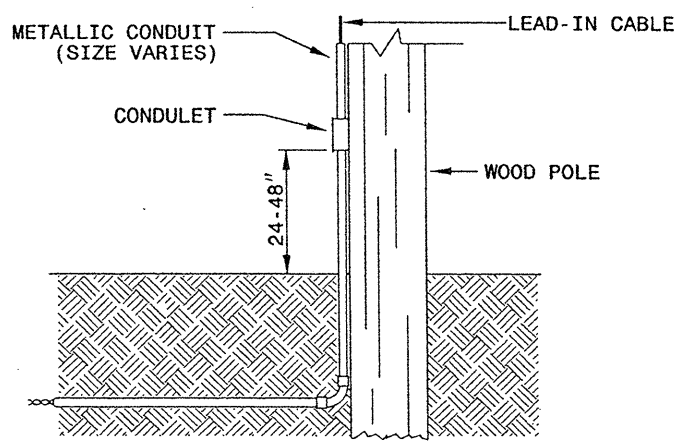

NOTE

SPLICE ALL LOOP WIRE TAIL SECTIONS/LEAD-IN CABLE IN JUNCTION BOXES OR APPROVED CONDULETS.

LOOP WIRE PAVEMENT EDGE DETAILS

LOOP WIRE AT CURB & GUTTER SECTION

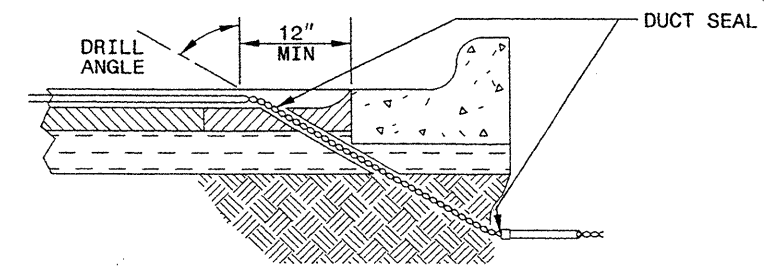

LOOP WIRE AT PAVEMENT SECTION

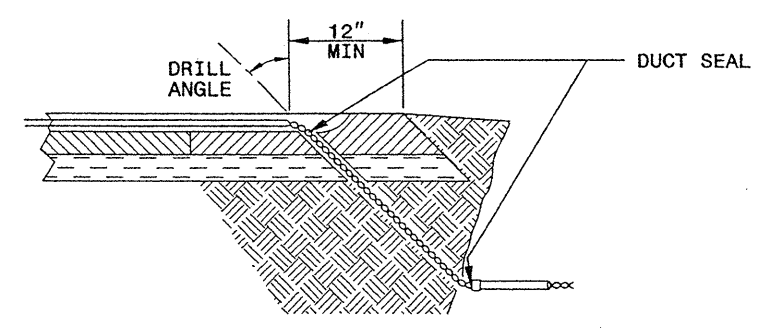

NOTES

1. DO NOT EXCAVATE UNDER CURB AND GUTTER SECTIONS FOR CONDUIT INSTALLATION.
2. TWIST LOOP WIRE TAIL SECTIONS FROM WHERE LOOP WIRE TAIL LEAVES SAW CUT TO JUNCTION BOX, INCLUDING THROUGH CONDUIT.
3. BEFORE SEALING LOOPS, INSTALL DUCT SEAL WHERE LOOP WIRE TAIL SECTION LEAVES SAW CUT IN PAVEMENT AND AT ENTRANCE OF CONDUIT TO JUNCTION BOX.

STATE OF NORTH CAROLINA
DEPT. OF TRANSPORTATION
DIVISION OF HIGHWAYS
RALEIGH, N.C.

5-07

ENGLISH DETAIL DRAWING FOR
INDUCTIVE DETECTION LOOPS
LOOP WIRE DETAILS

SHEET 2 OF 3
1725D01

05-SEP-2007 14:00 c:\pdocuments and settings\smittle-d\msk\topostandard\metal pole sheets\1725D01.dgn smittle

See Plate for Title

Prepared in the Offices of:
Intelligent Transportation Systems & Signals Unit
750 N. Greenfield Parkway
Garner, NC 27529

SEAL
NORTH CAROLINA PROFESSIONAL SEAL 016286 ENGINEER MILTON I. DENN
Milton I. Denn 9/5/07
SIGNATURE DATE

STATE OF NORTH CAROLINA
DEPT. OF TRANSPORTATION
DIVISION OF HIGHWAYS
RALEIGH, N.C.

5-07

ENGLISH DETAIL DRAWING FOR
INDUCTION DETECTION LOOPS
SPlicing FOR LEAD-IN CABLE AND LOOP WIRE

SHEET 3 OF 3
1725D01

STEP 1. STRIP LOOP WIRE AND LEAD-IN CABLE

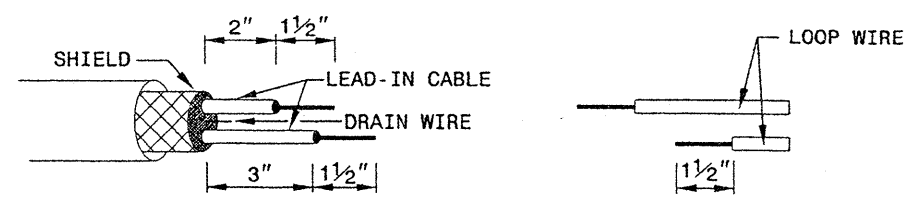

STEP 2. CONNECT AND SOLDER

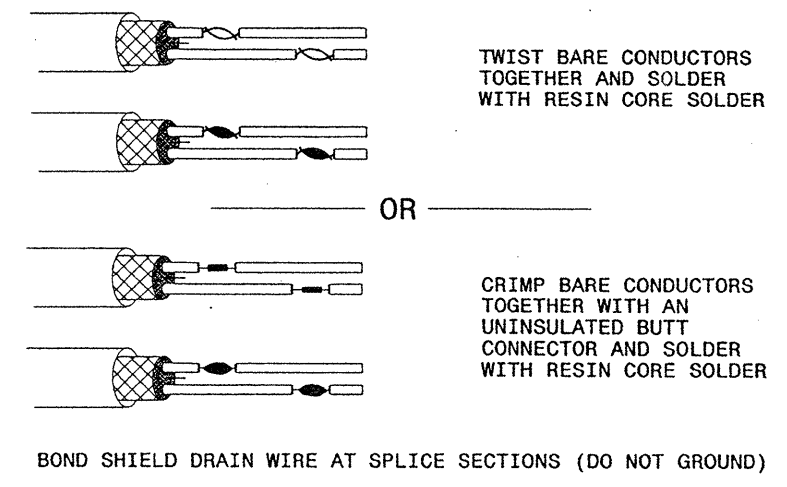

LOOP WIRE AND LEAD-IN CABLE CONNECTION DETAILS

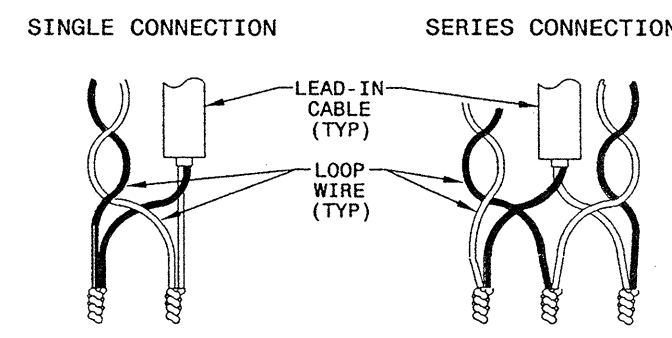

STEP 3. INSULATE EACH SOLDER JOINT SEPARATELY

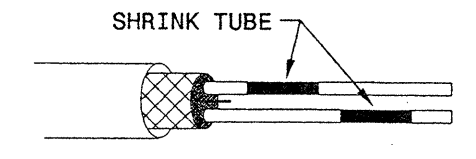

STEP 4. ENVIRONMENTALLY PROTECT SPLICE

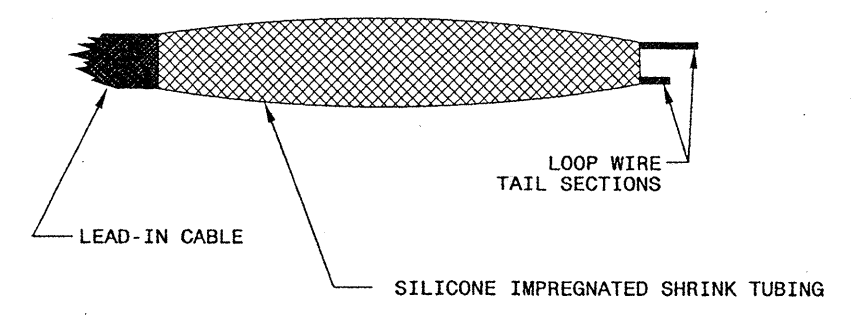

STATE OF NORTH CAROLINA
DEPT. OF TRANSPORTATION
DIVISION OF HIGHWAYS
RALEIGH, N.C.

5-07

ENGLISH DETAIL DRAWING FOR
INDUCTIVE DETECTION LOOPS
SPlicing FOR LEAD-IN CABLE AND LOOP WIRE

SHEET 3 OF 3
1725D01

See Plate for Title

Prepared in the Offices of:

750 N. Greenfield Parkway
Garner, NC 27529

SEAL

SEAL
016286
ENGINEER
MILTON I. DEAN

Milton I. Dean 9/5/07
SIGNATURE DATE

06-SEP-2007 14:01 c:\documents and settings\smittle\d\asktop\standard metal pole sheets\1725D01.mxd 2/07.dgn zml1111e