

PAVEMENT MARKING SCHEDULE



PROJ. REFERENCE NO.	SHEET NO.
R-2301A	PMP-01

SYMBOL	DESCRIPTION	QUANTITY BREAKDOWN	PAY ITEM	TOTAL QUANTITY
PAVEMENT MARKING LINES				
C6	WHITE EDGE LINE	318 M	COLD APPLIED PLASTIC (150mm,TYPE III)	728 M
C7	YELLOW EDGE LINE	318 M		
CK	3m WHITE SKIP	92 M		
TA	WHITE EDGE LINE	1,890 M	THERMOPLASTIC (100mm,2.3mm)	2,766 M
TB	YELLOW EDGE LINE	876 M		
TC	3m WHITE SKIP	295 M	THERMOPLASTIC (100mm,3.1mm)	1,415 M
TD	0.5m WHITE MINISKIP	85 M		
TE	WHITE SOLID LANE LINE	493 M		
TI	YELLOW DOUBLE CENTER LINE	542 M		
T6	WHITE EDGE LINE	24,039 M	THERMOPLASTIC (150mm,2.3mm)	47,180 M
T7	YELLOW EDGE LINE	23,141 M		
TJ	3m WHITE SKIP	5,447 M	THERMOPLASTIC (150mm,3.1mm)	5,725 M
TK	0.5m WHITE MINISKIP	74 M		
TL	WHITE SOLID LANE LINE	204 M		
TT	YELLOW DIAGONAL	16 M	THERMOPLASTIC (200mm,2.3mm)	16 M
TY	WHITE GORE LINE	1,082 M	THERMOPLASTIC (300mm,2.3mm)	1,082 M
T2	WHITE STOP BAR	52 M	THERMOPLASTIC (600mm,3.1mm)	52 M
PB	YELLOW EDGE LINE 2X	840 M	PAINT (100mm)	840 M
PL	0.5 WHITE MINISKIP	90 M	PAINT (150mm)	1,779 M
P6	WHITE EDGE LINE 2X	1,117 M		
P7	YELLOW EDGE LINE 2X	572 M		
PS	WHITE DIAGONAL 2X	262 M	PAINT (200mm)	262 M
PAVEMENT MARKING SYMBOLS				
UA	LEFT TURN ARROW	15 EA	THERMOPLASTIC SYMBOL	40 EA
UB	RIGHT TURN ARROW	6 EA		
UC	STRAIGHT ARROW	19 EA		
QC	STRAIGHT ARROW 2X	6 EA	PAINT SYMBOL	6 EA
QI	ALPHANUMERIC CHARACTER 2X	27 EA	PAINT CHARACTER	27 EA
PAVEMENT MARKERS				
ME	YELLOW & YELLOW	47 EA	SNOWFLOWABLE	737 EA
MF	CRYSTAL & RED	690 EA		

NOTE: FOR EACH PLAIN PAVEMENT MARKING ITEM, 1X IMPLIES A SINGLE APPLICATION, 2X IMPLIES TWO APPLICATIONS, AND 3X IMPLIES THREE APPLICATIONS

APPROVED:	DATE:	PAVEMENT MARKING SCHEDULE					
	SCALE:	NONE					
	DATE:	08-08					
	DWG. BY:	DWM					
	DESIGN BY:	MDL					
REVIEWED BY:	JAK	REVISIONS	<table border="1"> <tr> <td> </td> <td> </td> </tr> <tr> <td> </td> <td> </td> </tr> </table>				
		CADD FILE	R2301Ap01.PMP				



NOTE:
 DELINEATE MONOLITHIC CONCRETE ISLAND
 ON -Y1- WITH YELLOW EDGE LINE (100mm PAINT)
 AS DIRECTED BY THE ENGINEER.

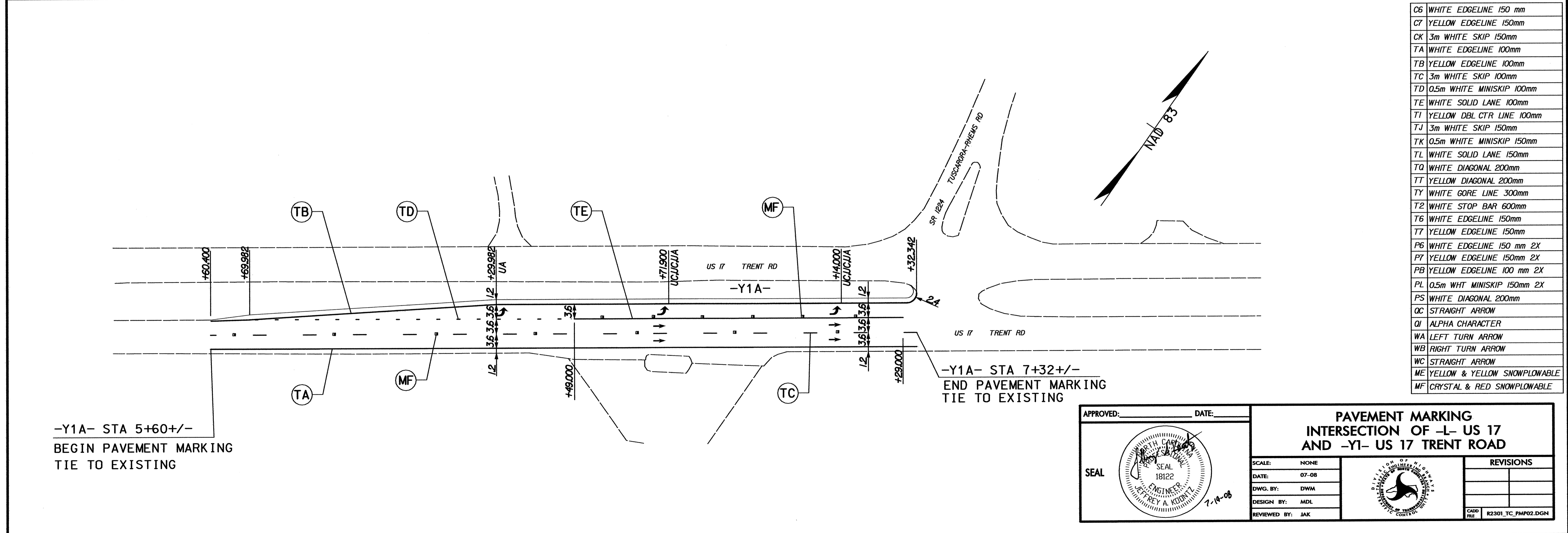
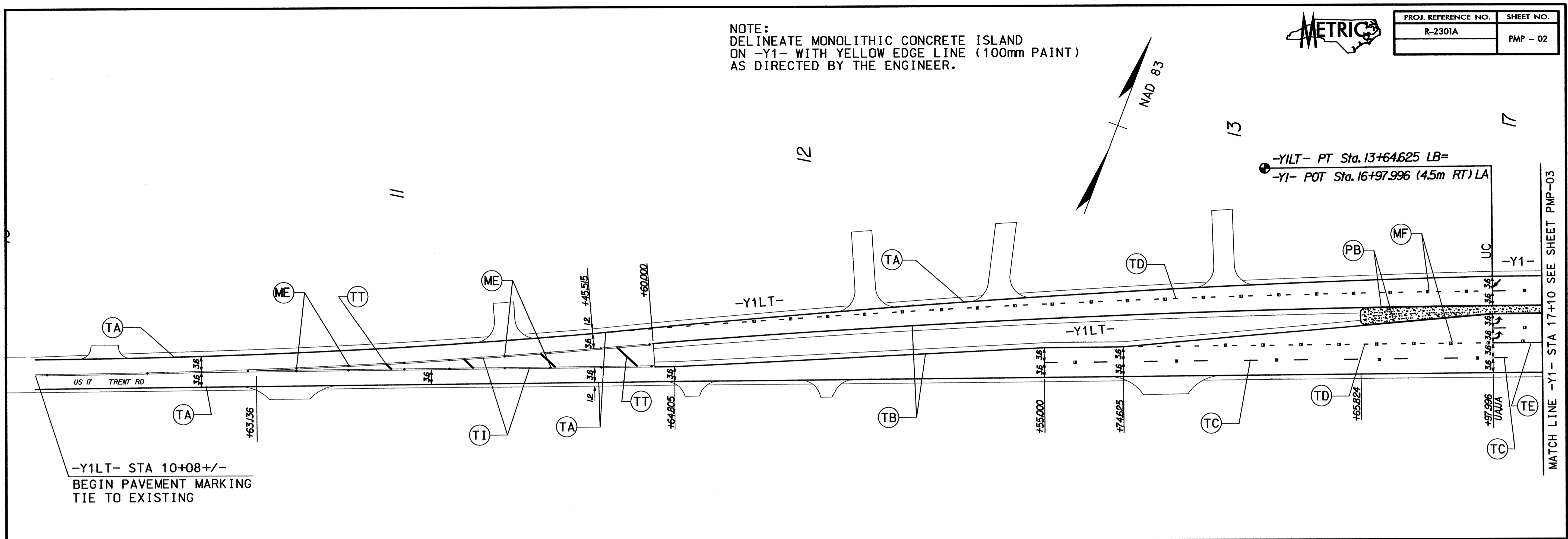

C6	WHITE EDGELINE 150 mm
C7	YELLOW EDGELINE 150mm
CK	3m WHITE SKIP 150mm
TA	WHITE EDGELINE 100mm
TB	YELLOW EDGELINE 100mm
TC	3m WHITE SKIP 100mm
TD	0.5m WHITE MINISKIP 100mm
TE	WHITE SOLID LANE 100mm
TI	YELLOW DBL CTR LINE 100mm
TJ	3m WHITE SKIP 150mm
TK	0.5m WHITE MINISKIP 150mm
TL	WHITE SOLID LANE 150mm
TQ	WHITE DIAGONAL 200mm
TT	YELLOW DIAGONAL 200mm
TY	WHITE GORE LINE 300mm
T2	WHITE STOP BAR 600mm
T6	WHITE EDGELINE 150mm
T7	YELLOW EDGELINE 150mm
P6	WHITE EDGELINE 150 mm 2X
P7	YELLOW EDGELINE 150mm 2X
PB	YELLOW EDGELINE 100 mm 2X
PL	0.5m WHIT MINISKIP 150mm 2X
PS	WHITE DIAGONAL 200mm
QC	STRAIGHT ARROW
QI	ALPHA CHARACTER
WA	LEFT TURN ARROW
WB	RIGHT TURN ARROW
WC	STRAIGHT ARROW
ME	YELLOW & YELLOW SNOWPLOWABLE
MF	CRYSTAL & RED SNOWPLOWABLE

APPROVED: _____ DATE: _____

SEAL

**PAVEMENT MARKING
 INTERSECTION -L- US 17
 AND -Y1- US 17 TRENT ROAD**

SCALE: NONE		REVISIONS
DATE: 07-08		
DWG. BY: DWM		
DESIGN BY: MDL		
REVIEWED BY: JAK		

CADD FILE: R2301_TC_PMP02.DGN

C6	WHITE EDGELINE 150 mm
C7	YELLOW EDGELINE 150mm
CK	3m WHITE SKIP 150mm
TA	WHITE EDGELINE 100mm
TB	YELLOW EDGELINE 100mm
TC	3m WHITE SKIP 100mm
TD	0.5m WHITE MINISKIP 100mm
TE	WHITE SOLID LANE 100mm
TI	YELLOW DBL CTR LINE 100mm
TJ	3m WHITE SKIP 150mm
TK	0.5m WHITE MINISKIP 150mm
TL	WHITE SOLID LANE 150mm
TQ	WHITE DIAGONAL 200mm
TT	YELLOW DIAGONAL 200mm
TY	WHITE GORE LINE 300mm
T2	WHITE STOP BAR 600mm
T6	WHITE EDGELINE 150mm
T7	YELLOW EDGELINE 150mm
P6	WHITE EDGELINE 150 mm 2X
P7	YELLOW EDGELINE 150mm 2X
PB	YELLOW EDGELINE 100 mm 2X
PL	0.5m WHT MINISKIP 150mm 2X
PS	WHITE DIAGONAL 200mm
QC	STRAIGHT ARROW
QI	ALPHA CHARACTER
WA	LEFT TURN ARROW
WB	RIGHT TURN ARROW
WC	STRAIGHT ARROW
ME	YELLOW & YELLOW SNOWPLOWABLE
MF	CRYSTAL & RED SNOWPLOWABLE

PROJ. REFERENCE NO.	SHEET NO.
R-2301A	PMP - 03

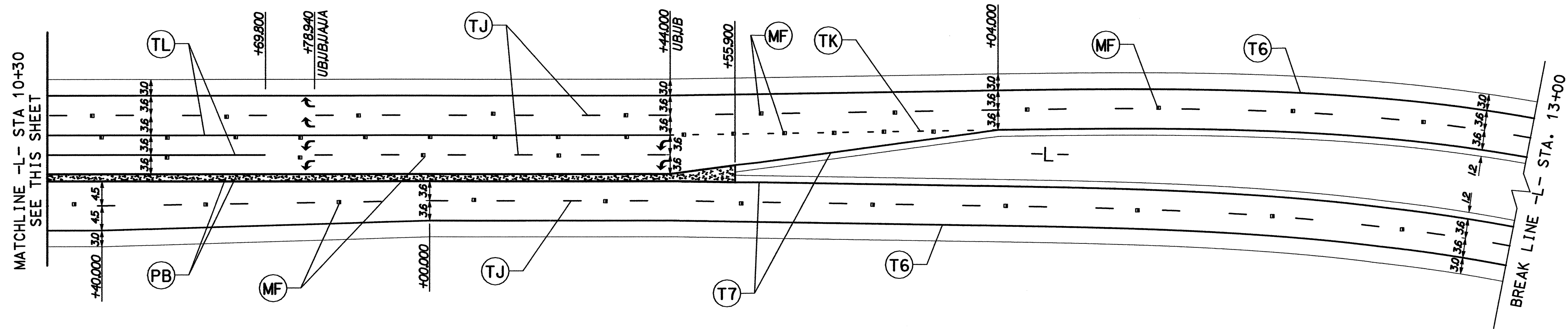
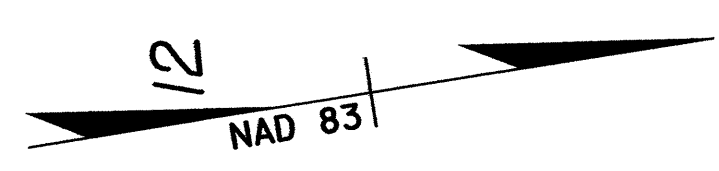

NOTE:
 DELINEATE MONOLITHIC CONCRETE ISLANDS
 ON -L- AND -Y1- WITH YELLOW EDGE LINE
 (100mm PAINT) AS DIRECTED BY THE ENGINEER.

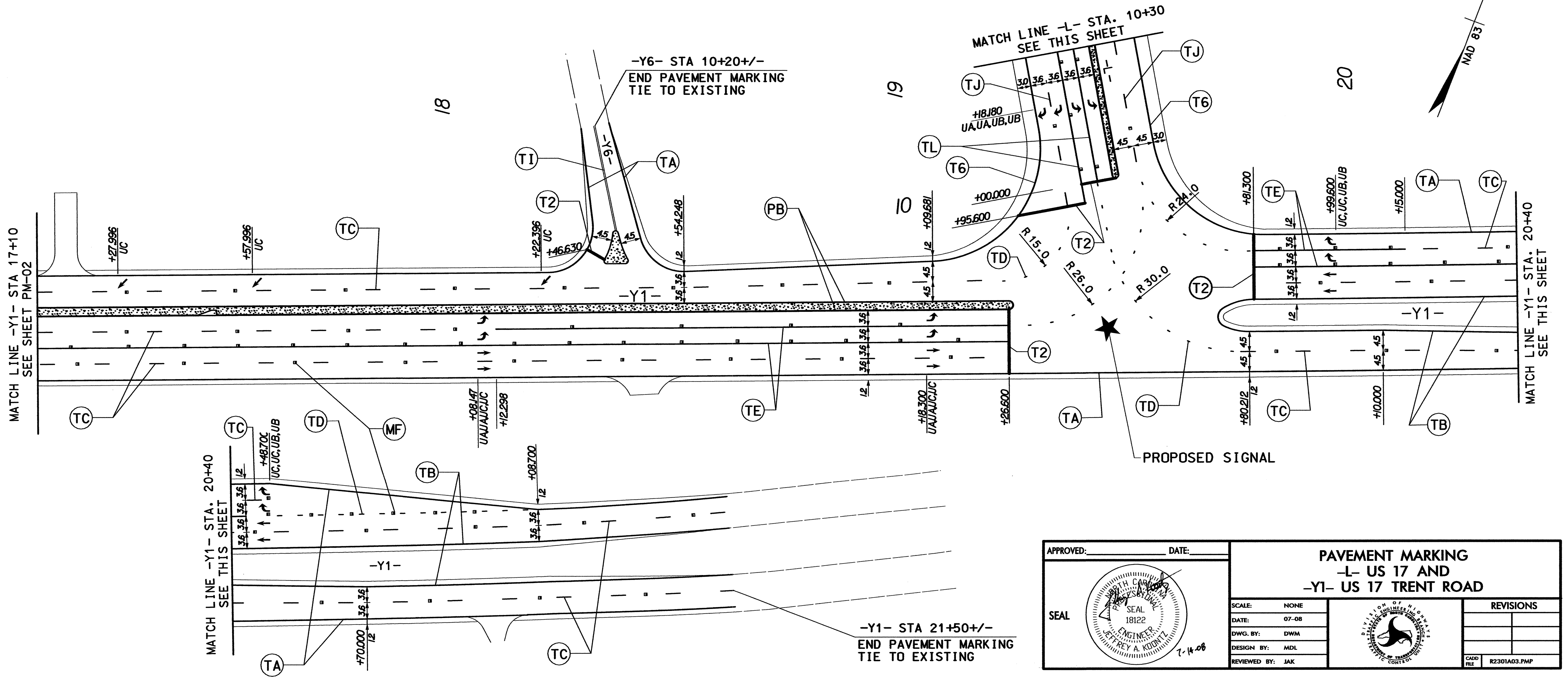

APPROVED: _____ DATE: _____

SEAL

PAVEMENT MARKING -L- US 17 AND -Y1- US 17 TRENT ROAD	
SCALE: NONE	REVISIONS
DATE: 07-08	
DWG. BY: DWM	
DESIGN BY: MDL	
REVIEWED BY: JAK	
CADD FILE: R2301A03.PMP	



MATCH LINE -L- STA. 97+50
SEE SHEET PMP-06

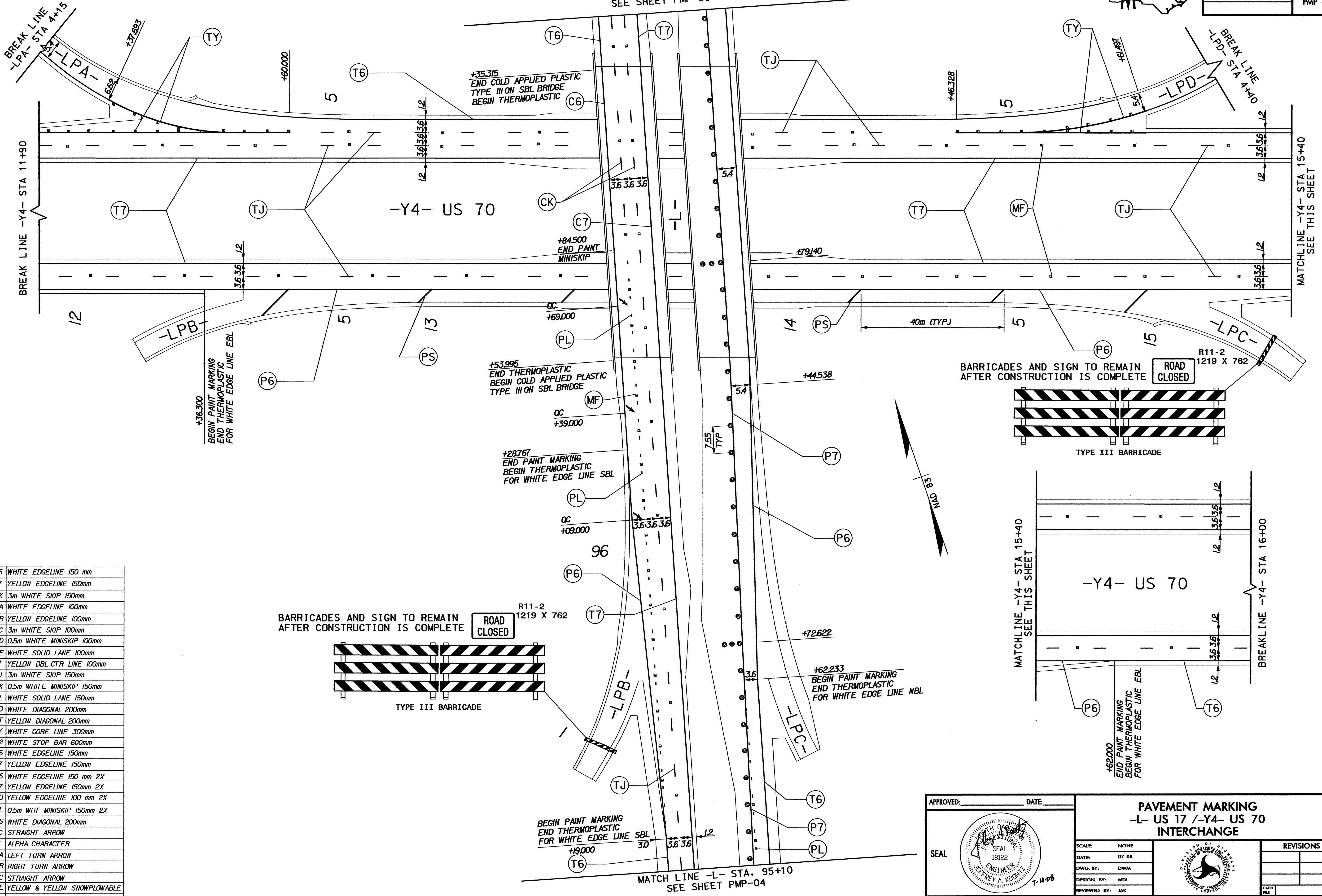

C6	WHITE EDGELINE 150 mm
C7	YELLOW EDGELINE 150mm
CK	3m WHITE SKIP 150mm
TA	WHITE EDGELINE 100mm
TB	YELLOW EDGELINE 100mm
TC	3m WHITE SKIP 100mm
TD	0.5m WHITE MINISKIP 100mm
TE	WHITE SOLID LANE 100mm
TI	YELLOW DBL CTR LINE 100mm
TJ	3m WHITE SKIP 150mm
TK	0.5m WHITE MINISKIP 150mm
TL	WHITE SOLID LANE 150mm
TQ	WHITE DIAGONAL 200mm
TT	YELLOW DIAGONAL 200mm
TY	WHITE GORE LINE 300mm
T2	WHITE STOP BAR 600mm
T6	WHITE EDGELINE 150mm
T7	YELLOW EDGELINE 150mm
P6	WHITE EDGELINE 150 mm 2X
P7	YELLOW EDGELINE 150mm 2X
PB	YELLOW EDGELINE 100 mm 2X
PL	0.5m WHT MINISKIP 150mm 2X
PS	WHITE DIAGONAL 200mm
QC	STRAIGHT ARROW
QI	ALPHA CHARACTER
WA	LEFT TURN ARROW
WB	RIGHT TURN ARROW
WC	STRAIGHT ARROW
ME	YELLOW & YELLOW SNOWPLOWABLE
MF	CRYSTAL & RED SNOWPLOWABLE

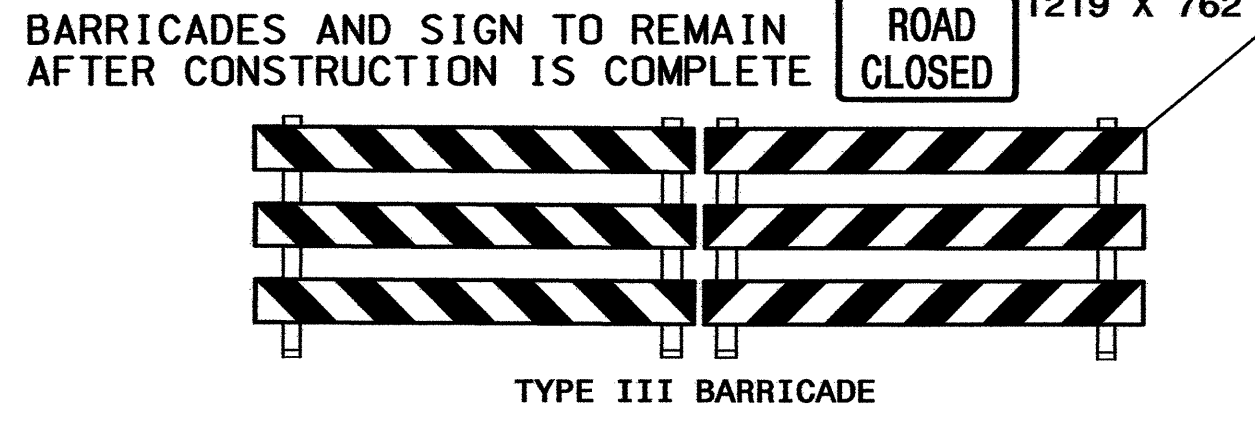
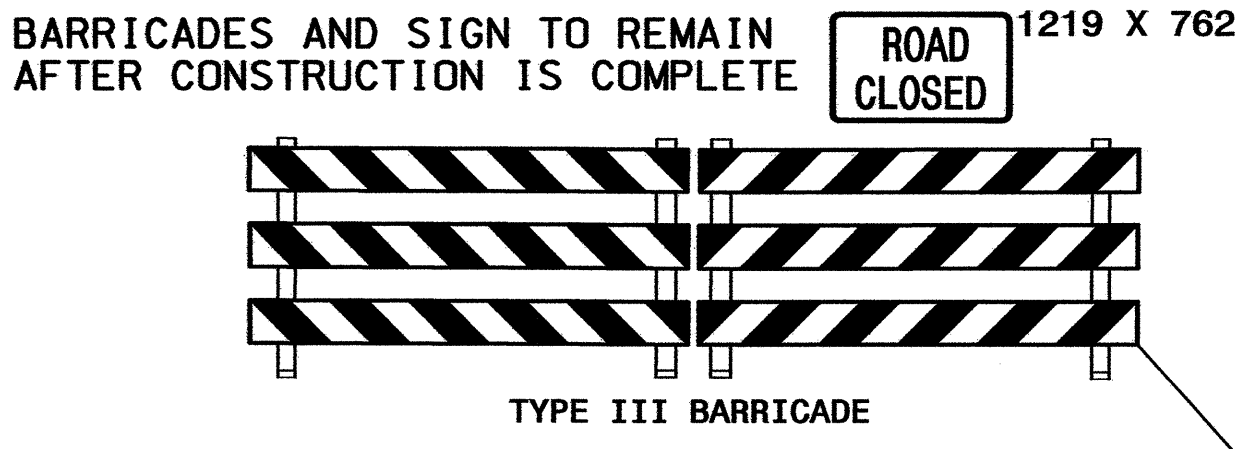

APPROVED: _____ DATE: _____	PAVEMENT MARKING -L- US 17 / -Y4- US 70 INTERCHANGE		REVISIONS	
			SCALE: NONE	DATE: 07-08
SEAL	DWG. BY: DWM	DESIGN BY: MDL	REVIEWED BY: JAK	



PROJ. REFERENCE NO.	SHEET NO.
R-2301A	PMP - 06

C6	WHITE EDGELINE 150 mm
C7	YELLOW EDGELINE 150mm
CK	3m WHITE SKIP 150mm
TA	WHITE EDGELINE 100mm
TB	YELLOW EDGELINE 100mm
TC	3m WHITE SKIP 100mm
TD	0.5m WHITE MINISKIP 100mm
TE	WHITE SOLID LANE 100mm
TI	YELLOW DBL CTR LINE 100mm
TJ	3m WHITE SKIP 150mm
TK	0.5m WHITE MINISKIP 150mm
TL	WHITE SOLID LANE 150mm
TQ	WHITE DIAGONAL 200mm
TT	YELLOW DIAGONAL 200mm
TY	WHITE GORE LINE 300mm
T2	WHITE STOP BAR 600mm
T6	WHITE EDGELINE 150mm
T7	YELLOW EDGELINE 150mm
P6	WHITE EDGELINE 150 mm 2X
P7	YELLOW EDGELINE 150mm 2X
PB	YELLOW EDGELINE 100 mm 2X
PL	0.5m WHT MINISKIP 150mm 2X
PS	WHITE DIAGONAL 200mm
QC	STRAIGHT ARROW
QI	ALPHA CHARACTER
WA	LEFT TURN ARROW
WB	RIGHT TURN ARROW
WC	STRAIGHT ARROW
ME	YELLOW & YELLOW SNOWPLOWABLE
MF	CRYSTAL & RED SNOWPLOWABLE

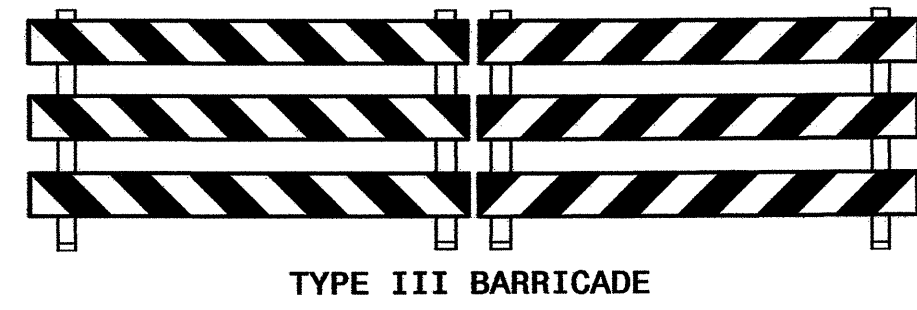

TYPE III BARRICADE

END PAVEMENT MARKING
PROJECT R-2301A
-L- 98+38.234 LT

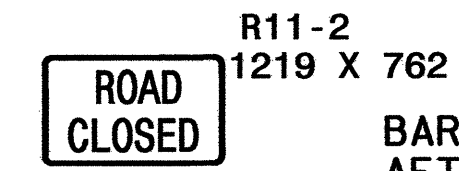

R11-2
1219 X 762

BARRICADES AND SIGN TO REMAIN
AFTER CONSTRUCTION IS COMPLETE

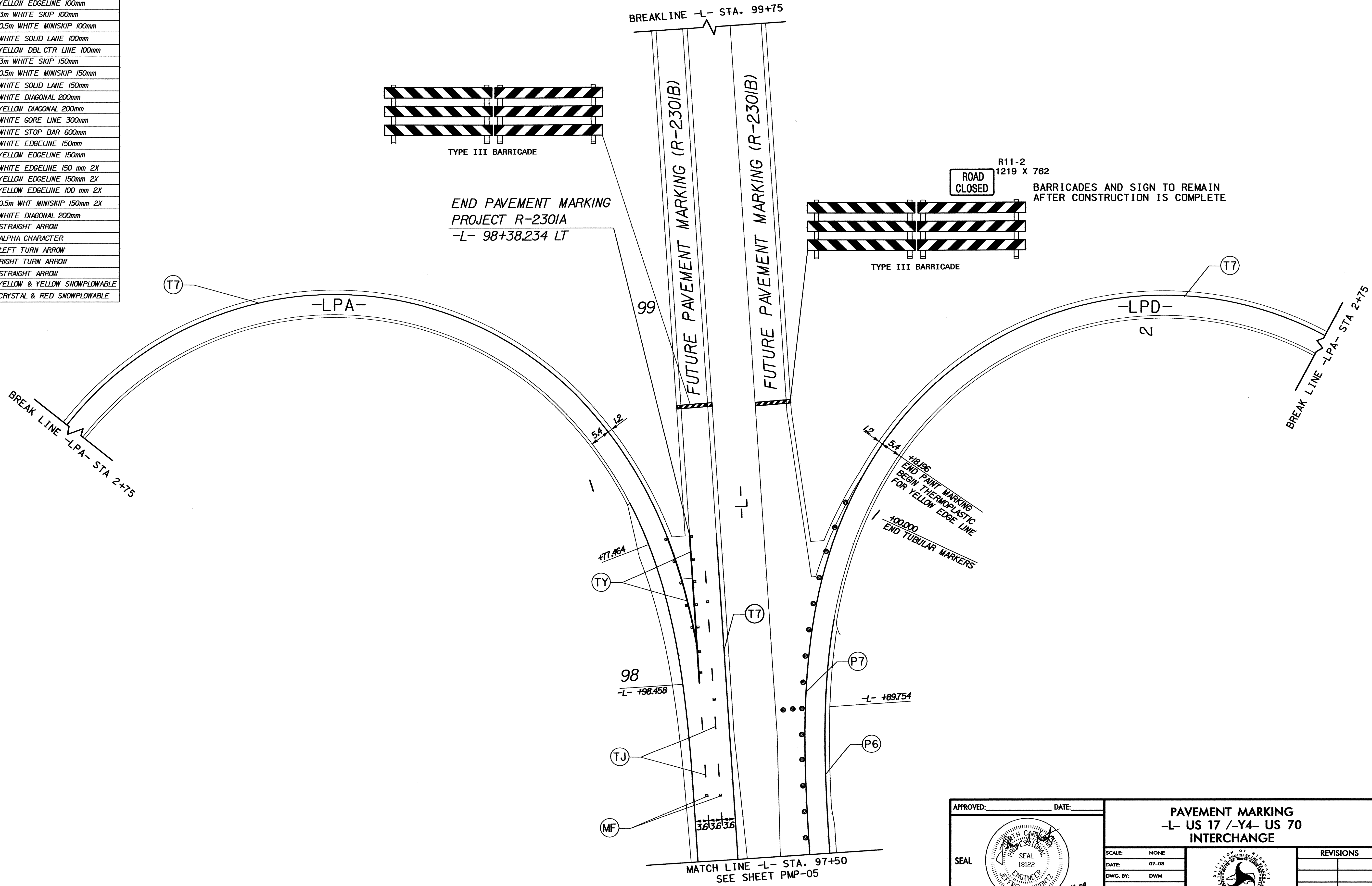

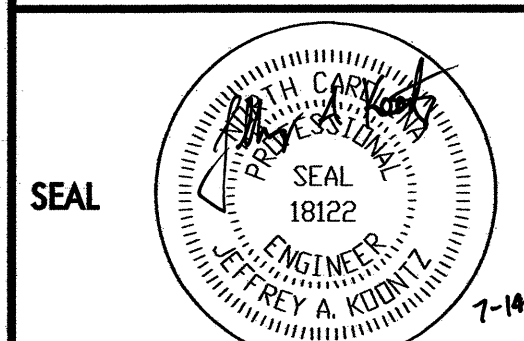
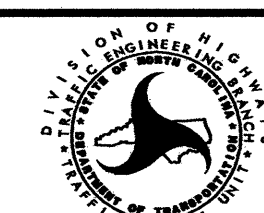
APPROVED: _____ DATE: _____	PAVEMENT MARKING -L- US 17 /-Y4- US 70 INTERCHANGE		REVISIONS						
			SCALE: NONE DATE: 07-08 DWG. BY: DWM DESIGN BY: MDL REVIEWED BY: JAK		<table border="1"> <tr><td> </td><td> </td></tr> <tr><td> </td><td> </td></tr> <tr><td> </td><td> </td></tr> </table>				
MATCH LINE -L- STA. 97+50 SEE SHEET PMP-05		CADD FILE: R2301A05.PMP							



PROJ. REFERENCE NO. R-2301A	SHEET NO. PMP - 07
--------------------------------	-----------------------

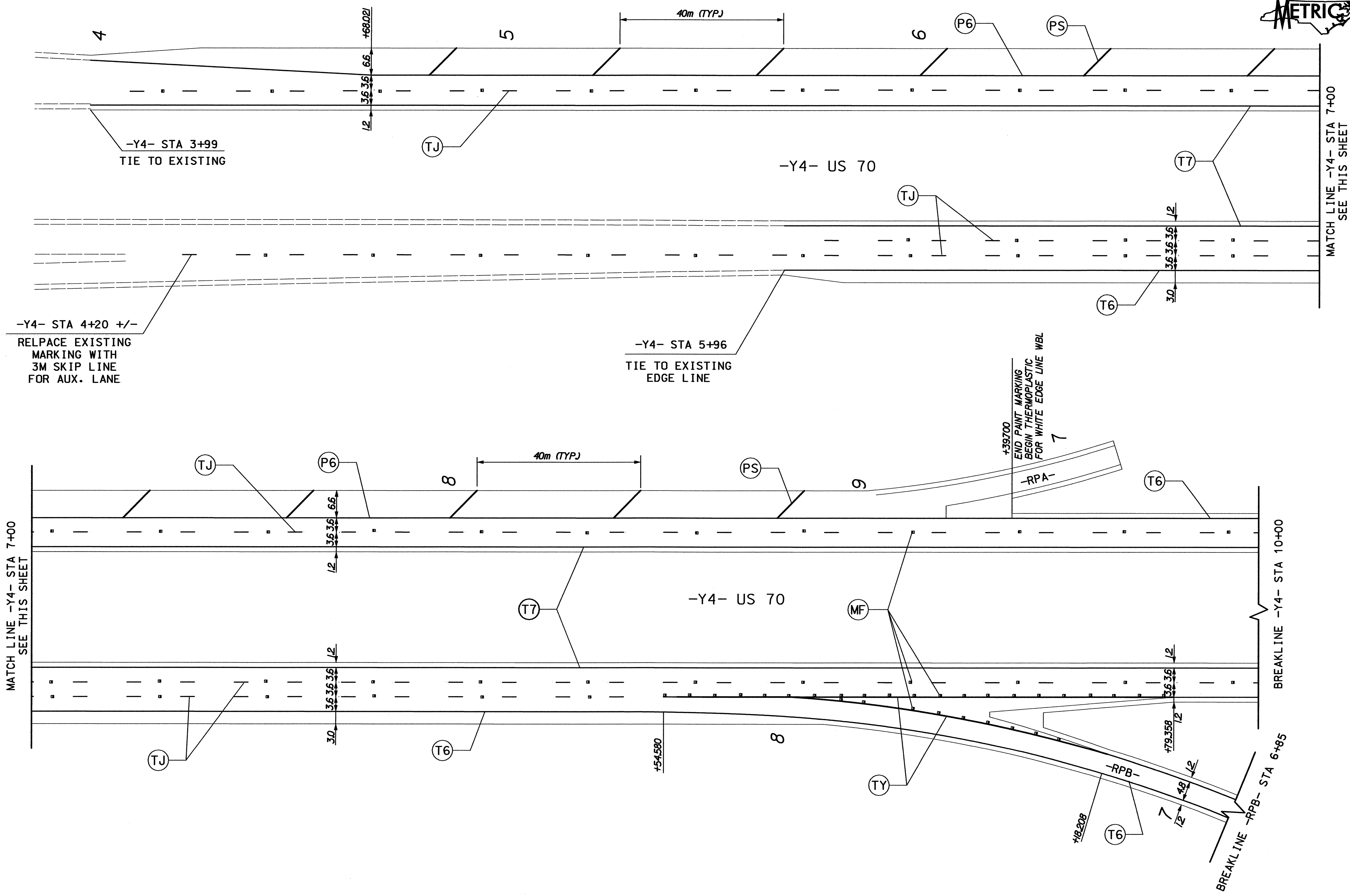
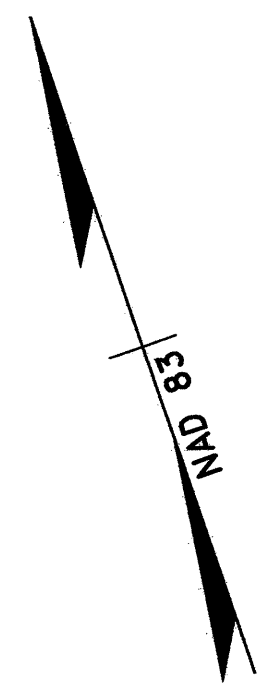

C6	WHITE EDGELINE 150 mm
C7	YELLOW EDGELINE 150mm
CK	3m WHITE SKIP 150mm
TA	WHITE EDGELINE 100mm
TB	YELLOW EDGELINE 100mm
TC	3m WHITE SKIP 100mm
TD	0.5m WHITE MINISKIP 100mm
TE	WHITE SOLID LANE 100mm
TI	YELLOW DBL CTR LINE 100mm
TJ	3m WHITE SKIP 150mm
TK	0.5m WHITE MINISKIP 150mm
TL	WHITE SOLID LANE 150mm
TO	WHITE DIAGONAL 200mm
TT	YELLOW DIAGONAL 200mm
TY	WHITE GORE LINE 300mm
TZ	WHITE STOP BAR 600mm
T6	WHITE EDGELINE 150mm
T7	YELLOW EDGELINE 150mm
P6	WHITE EDGELINE 150 mm 2X
P7	YELLOW EDGELINE 150mm 2X
PB	YELLOW EDGELINE 100 mm 2X
PL	0.5m WHT MINISKIP 150mm 2X
PS	WHITE DIAGONAL 200mm
QC	STRAIGHT ARROW
QI	ALPHA CHARACTER
WA	LEFT TURN ARROW
WB	RIGHT TURN ARROW
WC	STRAIGHT ARROW
ME	YELLOW & YELLOW SNOWPLOWABLE
MF	CRYSTAL & RED SNOWPLOWABLE

APPROVED: _____ DATE: _____

SEAL

7-4-08

PAVEMENT MARKING
-L- US 17 /-Y4- US 70
INTERCHANGE

SCALE: NONE
DATE: 07-08
DWG. BY: DWM
DESIGN BY: MDL
REVIEWED BY: JAK

REVISIONS

CHD FILE: R2301A06.PMP



PROJ. REFERENCE NO.	SHEET NO.
R-2301A	PMP - 09

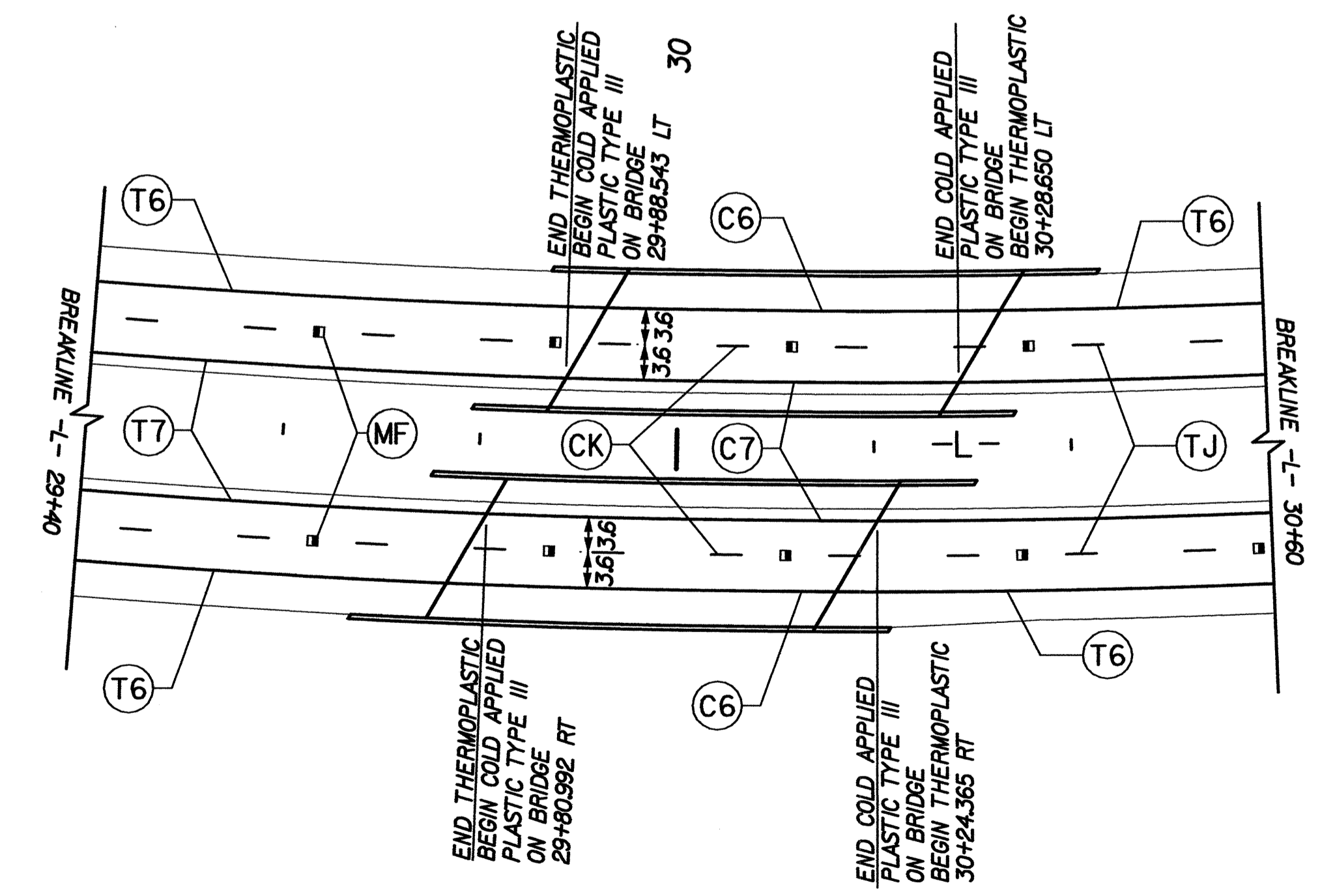
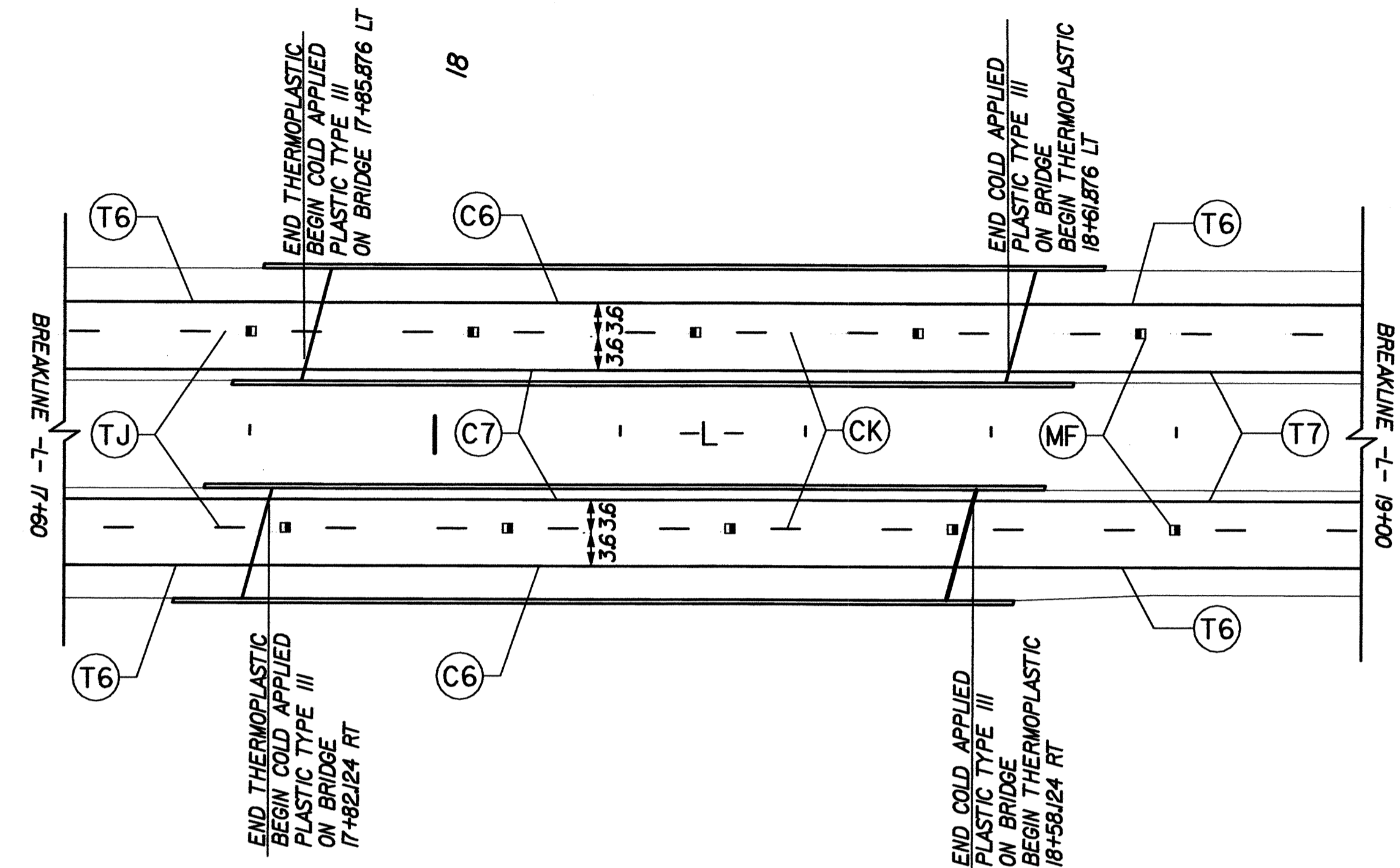
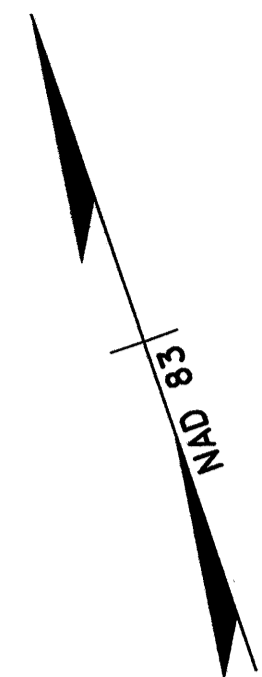

C6	WHITE EDGELINE 150 mm
C7	YELLOW EDGELINE 150mm
CK	3m WHITE SKIP 150mm
TA	WHITE EDGELINE 100mm
TB	YELLOW EDGELINE 100mm
TC	3m WHITE SKIP 100mm
TD	0.5m WHITE MINISKIP 100mm
TE	WHITE SOLID LANE 100mm
TJ	YELLOW DBL CTR LINE 100mm
TJ	3m WHITE SKIP 150mm
TK	0.5m WHITE MINISKIP 150mm
TL	WHITE SOLID LANE 150mm
TQ	WHITE DIAGONAL 200mm
TT	YELLOW DIAGONAL 200mm
TY	WHITE GORE LINE 300mm
T2	WHITE STOP BAR 600mm
T6	WHITE EDGELINE 150mm
T7	YELLOW EDGELINE 150mm
P6	WHITE EDGELINE 150 mm 2X
P7	YELLOW EDGELINE 150mm 2X
PB	YELLOW EDGELINE 100 mm 2X
PL	0.5m WHT MINISKIP 150mm 2X
PS	WHITE DIAGONAL 200mm
QC	STRAIGHT ARROW
QI	ALPHA CHARACTER
WA	LEFT TURN ARROW
WB	RIGHT TURN ARROW
WC	STRAIGHT ARROW
ME	YELLOW & YELLOW SNOWPLOWABLE
MF	CRYSTAL & RED SNOWPLOWABLE

APPROVED: _____ DATE: _____	PAVEMENT MARKING -L- US 17 BRIDGES		REVISIONS							
			SCALE: NONE		<table border="1"> <tr><td> </td><td> </td></tr> <tr><td> </td><td> </td></tr> <tr><td> </td><td> </td></tr> </table>					
DATE: 07-08	DESIGN BY: MDL	CADD FILE	R2301A06.PMP							
DWG. BY: DWM	REVIEWED BY: JAK									