

## FINAL PAVEMENT MARKING SCHEDULE

<u>SYMBOL</u>	<u>DESCRIPTION</u>	<u>BREAKDOWN</u>		<u>TOTAL QUANTITY</u>		
<u>THERMOPLASTIC (24", 120 MILS)</u>						
T2	WHITE STOPBAR	200	LF	TOTAL	200	LF
<u>THERMOPLASTIC (4", 120 MILS)</u>						
TC	0 FT. WHITE SKIP	898	LF	TOTAL	6259	LF
TD	2 FT. WHITE MINISKIP	126	LF			
TE	WHITE SOLID LANE LINE	890	LF			
TF	10 FT. YELLOW SKIP	369	LF			
TH	YELLOW SINGLE CENTER	1476	LF			
TI	YELLOW DOUBLE CENTER	2500	LF			
<u>THERMOPLASTIC (8", 90 MILS)</u>						
TQ	WHITE DIAGONAL	100	LF	TOTAL	100	LF
<u>THERMOPLASTIC PAVEMENT MARKING CHARACTER (120 MILS)</u>						
UI	ALPHANUMERIC CHAR.	12	EA	TOTAL	12	EA
<u>THERMOPLASTIC PAVEMENT MARKING SYMBOLS (90 MILS)</u>						
UA	LEFT TURN ARROW	11	EA	TOTAL	20	EA
UB	RIGHT TURN ARROW	7	EA			
UC	STRAIGHT ARROW	2	EA			
<u>SNOWPLOWABLE RAISED PAVEMENT MARKERS</u>						
ME	YELLOW & YELLOW	115	EA	TOTAL	234	EA
MF	CRYSTAL & RED	119	EA			
<u>COLD APPLIED PLASTIC (4") Type3</u>						
CC	10 FT. WHITE SKIP	100	LF	TOTAL	322	LF
CD	2 FT. WHITE MINISKIP	12	LF			
CE	WHITE SOLID LANE LINE	110	LF			
CF	10 FT. YELLOW SKIP	100	LF			
<u>COLD APPLIED PLASTIC PAVEMENT MARKING SYMBOL Type3</u>						
DA	LEFT TURN ARROW	2	EA	TOTAL	3	EA
DB	RIGHT TURN ARROW	1	Ea			

15-MAY-2008 10:05  
 \\dot\dfsroot\proj\p\projects-b\4033\traffic\trafficcontrol\top\B-4033\_TC\_PMP\_1.dgn  
 mmanriquez AT WZIC224099

APPROVED: <i>M. M. Durand</i> DATE: 5/15/08		<b>FINAL PAVEMENT MARKING SCHEDULE</b>	
	SCALE: NONE		REVISIONS
	DATE: APR 08		
	DWG. BY: MM		
	DESIGN BY: MM		
	REVIEWED BY: CH		CADD FILE

### SYMBOL LEGEND

	UA LEFT TURN ARROW
	UB RIGHT TURN ARROW
	UC STRAIGHT ARROW
ONLY	UI ALPHANUMERIC CHARACTER

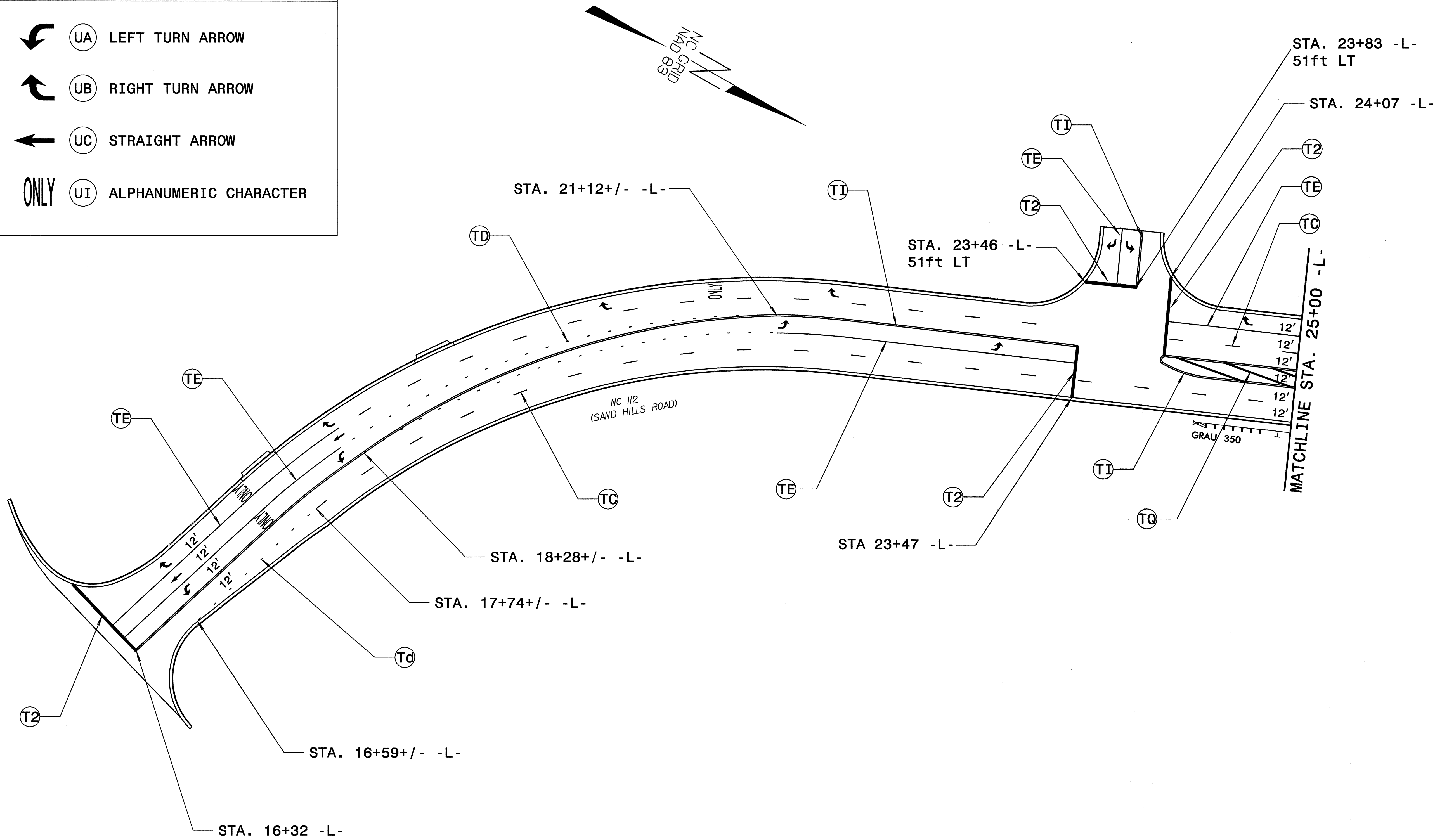



15-MAY-2008 10:05  
 \\dot\dfsroot\proj\1\p\projects-b\4033\traffic\control\top\B-4033-TC-PMP\_2.dgn  
 mmdr\lquez AT WZ\224099

SEE 2006 NC DOT ROADWAY STANDARD DRAWING 1205.04 SHEET 1 AND 2 FOR PAVEMENT MARKING SYMBOL LOCATION AND 1205.05 SHEET 1 AND 1250.01 FOR SNOWPLAWABLE MARKER LOCATION.

APPROVED: <i>M. McSwain</i> DATE: 5/15/08	<b>FINAL PAVEMENT MARKING DETAIL</b>	
	SCALE: NONE	
	DATE: 10/2007	
	DWG. BY: MM	
	DESIGN BY: MM	
REVIEWED BY: CH	REVISIONS	

### SYMBOL LEGEND

	(UA) LEFT TURN ARROW
	(UB) RIGHT TURN ARROW

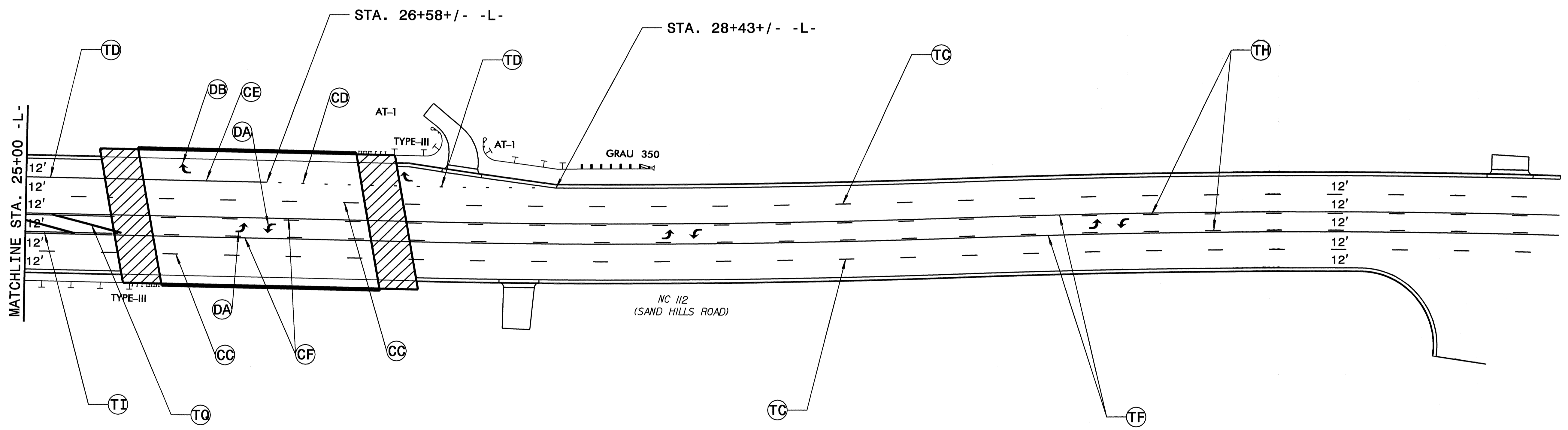
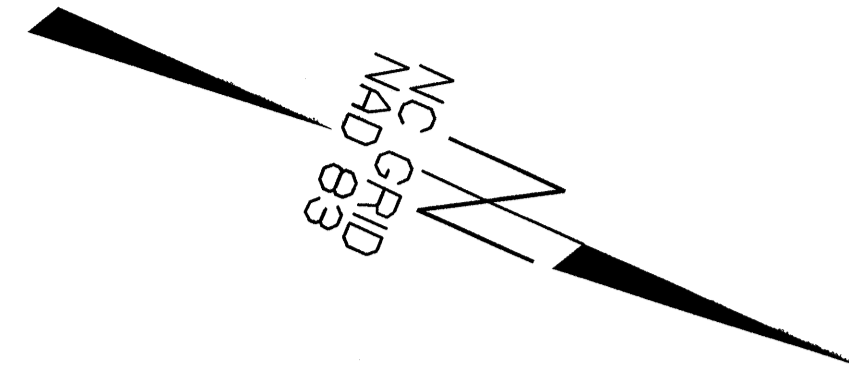

15-MAY-2008 10:06  
 \\dot\dfsroot\proj\1\ppr\objects-b\4033\traffico\top\B-4033\_TC\_PMP\_3.dgn  
 mmonriquez AT WZTC224099

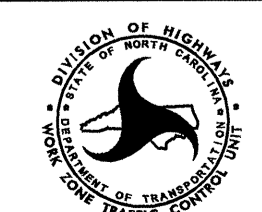
APPROVED: <i>[Signature]</i> DATE: 5/15/08		<b>FINAL PAVEMENT MARKING DETAIL</b>	
	SCALE: NONE		REVISIONS
	DATE: 10/2007		
	DWG. BY: MM		
	DESIGN BY: MM		
	REVIEWED BY: CH		