

FINAL PAVEMENT MARKING SCHEDULE

SYMBOL	DESCRIPTION
FINAL PAVEMENT MARKINGS	
	POLYUREA (4") Highly Reflective Elements
VA	WHITE EDGELINE
VB	YELLOW EDGELINE
VC	10 FT. WHITE SKIP
VD	2 FT. WHITE MINISKIP
VE	WHITE SOLID LANE LINE
VH	YELLOW SINGLE CENTER
VI	YELLOW DOUBLE CENTER
	POLYUREA (8") Highly Reflective Elements
VP	WHITE GORELINE
VQ	WHITE DIAGONAL
	POLYUREA (24") Highly Reflective Elements
V2	WHITE STOPBAR
	POLYUREA PAVEMENT MARKING SYMBOL Highly Reflective Elements
WA	LEFT TURN ARROW
WB	RIGHT TURN ARROW
WC	STRAIGHT ARROW
MARKERS	
	SNOWPLOWABLE RAISED PAVEMENT MARKERS
ME	YELLOW & YELLOW
MF	CRYSTAL & RED

I9-FEB-2008 13:17
 \\dot\dfs\0010\Proj\IP\Projects-R\2502B\Traffic\tr\afficocontrol\top\pmp\pmp-r-2502b-tc.pmp_01.dgn
 chaves AT WZTC22424

APPROVED: _____	DATE: _____	FINAL PAVEMENT MARKING PLAN								
	SCALE: NONE									
	DATE: 02/08									
	DWG. BY: DAH									
	DESIGN BY: DAH									
REVIEWED BY: JWW	<table border="1" style="width: 100%;"> <tr> <th colspan="2">REVISIONS</th> </tr> <tr> <td> </td> <td> </td> </tr> <tr> <td> </td> <td> </td> </tr> <tr> <td> </td> <td> </td> </tr> </table>		REVISIONS							
REVISIONS										
<small>CARD FILE</small>		<small>CARD FILE</small>								

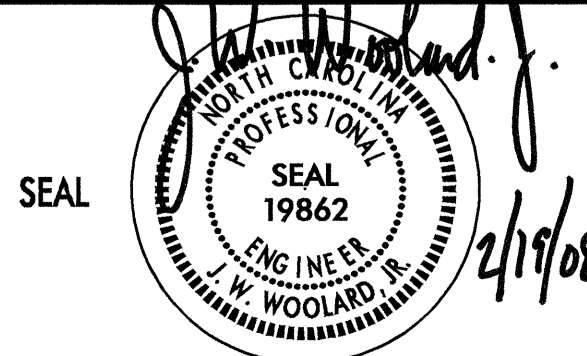
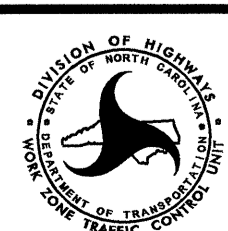
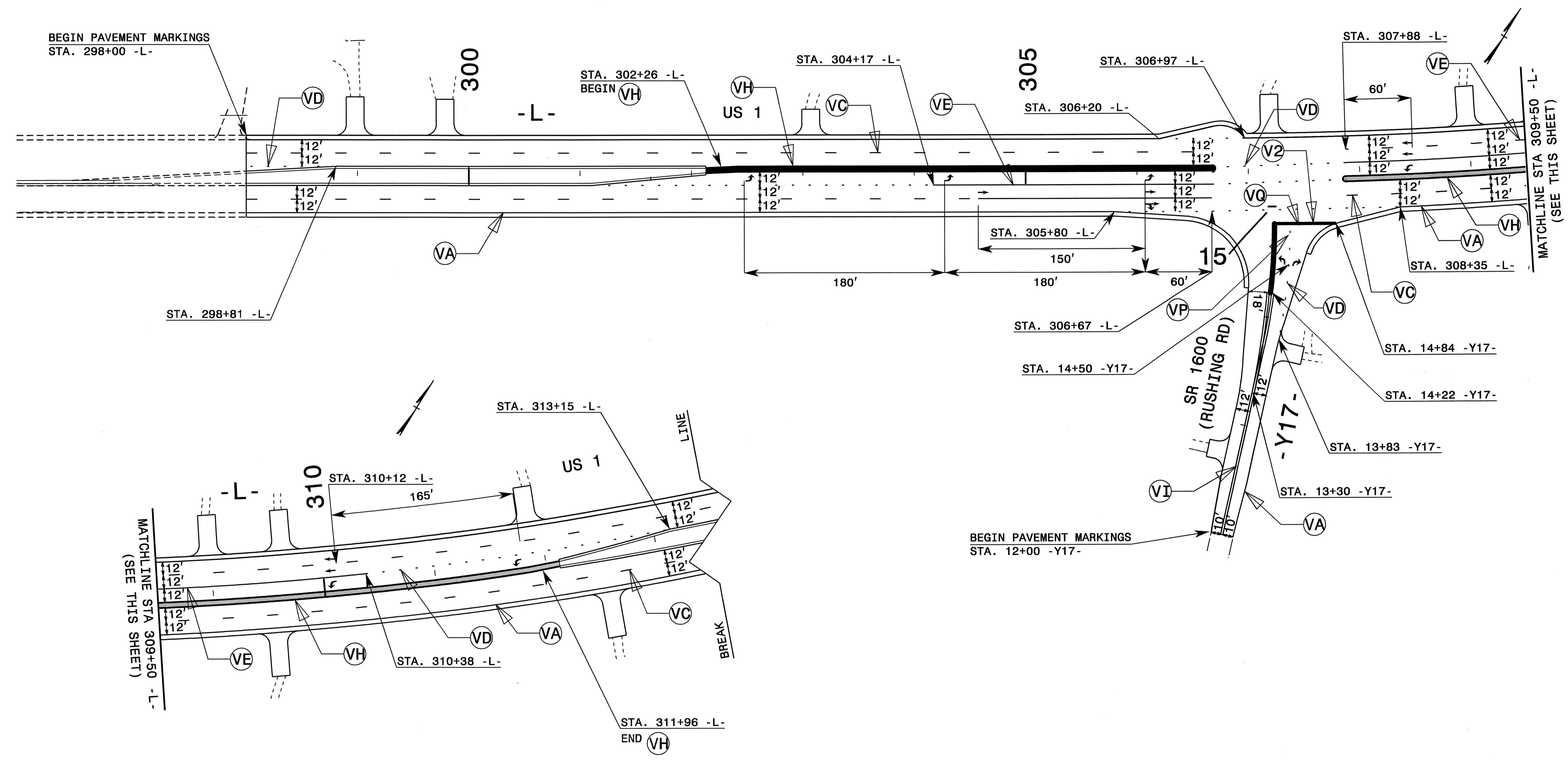

- : PROPOSED PAVEMENT MARKING LINE
- - - : EXISTING PAVEMENT MARKING LINE
- ↪ : WA ↪ : WD ↪ : WG
- ↪ : WB ↪ : WE
- ↪ : WC ↪ : WF
- ↪ : EXISTING PAVEMENT MARKING SYMBOL

VA	WHITE EDGELINE
VB	YELLOW EDGELINE
VC	10 FT. WHITE SKIP
VD	2 FT. WHITE MINISKIP
VE	WHITE SOLID LANE LINE
VH	YELLOW SINGLE CENTER
VI	YELLOW DOUBLE CENTER
VP	WHITE GORELINE
VQ	WHITE DIAGONAL
V2	WHITE STOPBAR

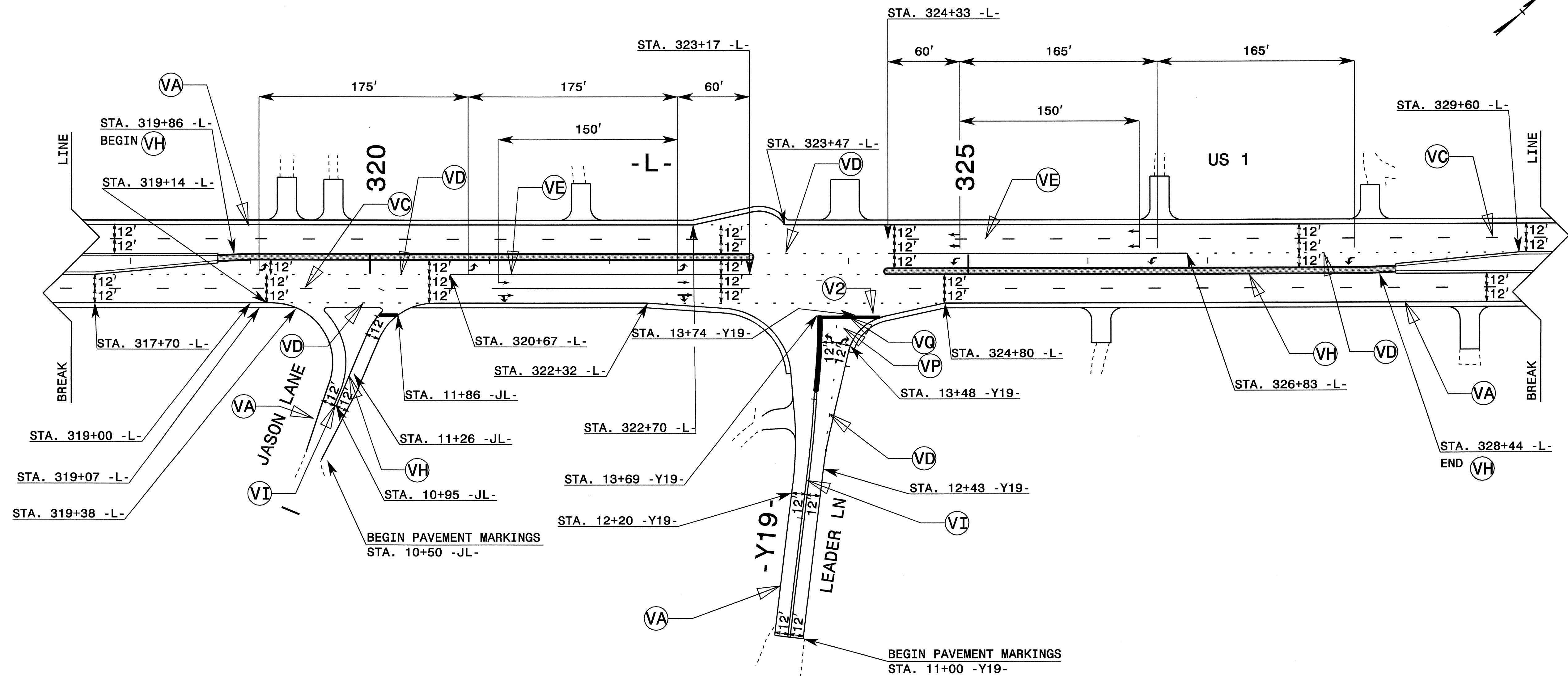

APPROVED: <i>[Signature]</i> DATE: 2/19/08	FINAL PAVEMENT MARKING PLAN									
SEAL: <i>[Professional Seal]</i>										
SCALE: NONE	DATE: 02/08	<table border="1"> <tr> <th colspan="2">REVISIONS</th> </tr> <tr> <td> </td> <td> </td> </tr> <tr> <td> </td> <td> </td> </tr> <tr> <td> </td> <td> </td> </tr> </table>	REVISIONS							
REVISIONS										
DWG. BY: DAH	DESIGN BY: DAH									
REVIEWED BY: JWW										

19-FEB-2008 09:11 \\dot\dfs\oof\Pro\IP\Projects-R\2502B\Traffic\Trafficcontrol\Top\pmp\R-2502B_TC_PMP_02.dgn AT WZTC224241

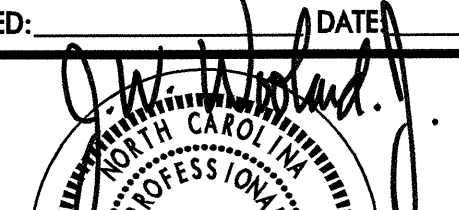
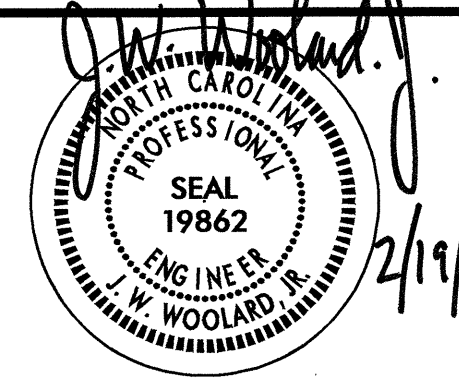

- : PROPOSED PAVEMENT MARKING LINE
- : EXISTING PAVEMENT MARKING LINE
- ↪ : WA ↪ : WD ↪ : WG
- ↪ : WB ↪ : WE
- ↪ : WC ↪ : WF
- ↪ : EXISTING PAVEMENT MARKING SYMBOL

VA	WHITE EDGELINE
VB	YELLOW EDGELINE
VC	10 FT. WHITE SKIP
VD	2 FT. WHITE MINISKIP
VE	WHITE SOLID LANE LINE
VH	YELLOW SINGLE CENTER
VI	YELLOW DOUBLE CENTER
VP	WHITE GORELINE
VQ	WHITE DIAGONAL
V2	WHITE STOPBAR

APPROVED: 	DATE: 2/19/08	FINAL PAVEMENT MARKING PLAN	
SEAL 			
SCALE: NONE	DATE: 02/08		REVISIONS
DWG. BY: DAH	DESIGN BY: DAH		
REVIEWED BY: JWW			

19-FEB-2008 09:10
 \\dot\dfsroot\proj\ip\proj\ip\proj\R2502B\Traffic\TrafficControl\Top\pmp\R-2502B_TC_PMP_03.dgn
 anayes AT WZTC22424

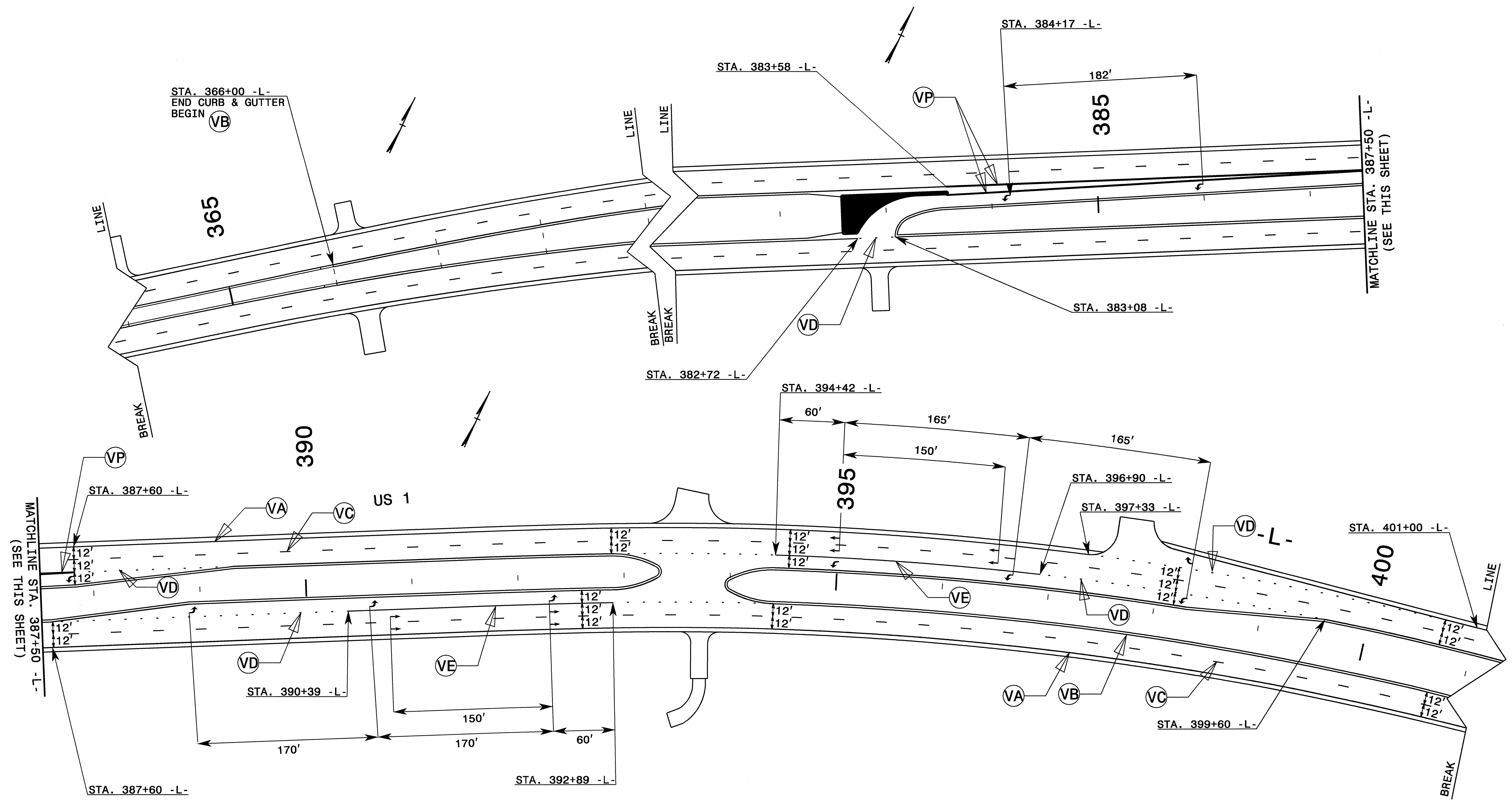

- : PROPOSED PAVEMENT MARKING LINE
- - - : EXISTING PAVEMENT MARKING LINE
- ↪ : WA ↪ : WD ↪ : WG
- ↪ : WB ↪ : WE
- ↪ : WC ↪ : WF
- ↪ : EXISTING PAVEMENT MARKING SYMBOL

VA	WHITE EDGELINE
VB	YELLOW EDGELINE
VC	10 FT. WHITE SKIP
VD	2 FT. WHITE MINISKIP
VE	WHITE SOLID LANE LINE
VH	YELLOW SINGLE CENTER
VI	YELLOW DOUBLE CENTER
VP	WHITE GORELINE
VQ	WHITE DIAGONAL
V2	WHITE STOPBAR

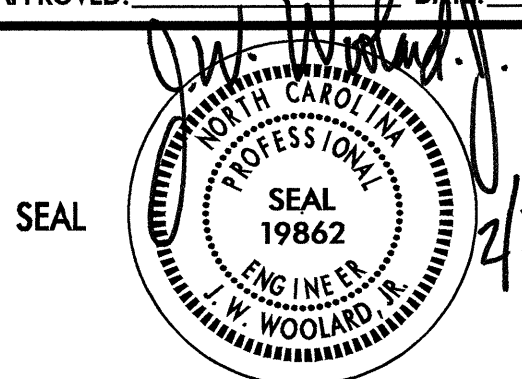
APPROVED: _____ DATE: _____	FINAL PAVEMENT MARKING PLAN							
								
SCALE: NONE	DATE: 02/08	<table border="1"> <tr> <th colspan="2">REVISIONS</th> </tr> <tr> <td> </td> <td> </td> </tr> <tr> <td> </td> <td> </td> </tr> </table>	REVISIONS					
REVISIONS								
DWG. BY: DAH	DESIGN BY: DAH	REVIEWED BY: JWW						

19-FEB-2008 09:10
 \\dot\dfs\0010\Proj\TIP\Projects-R\2502B\Traffic\TrafficControl\Top\pmp\VR-2502B_TC_PMP_04.dgn
 anayas AT WZTC24241

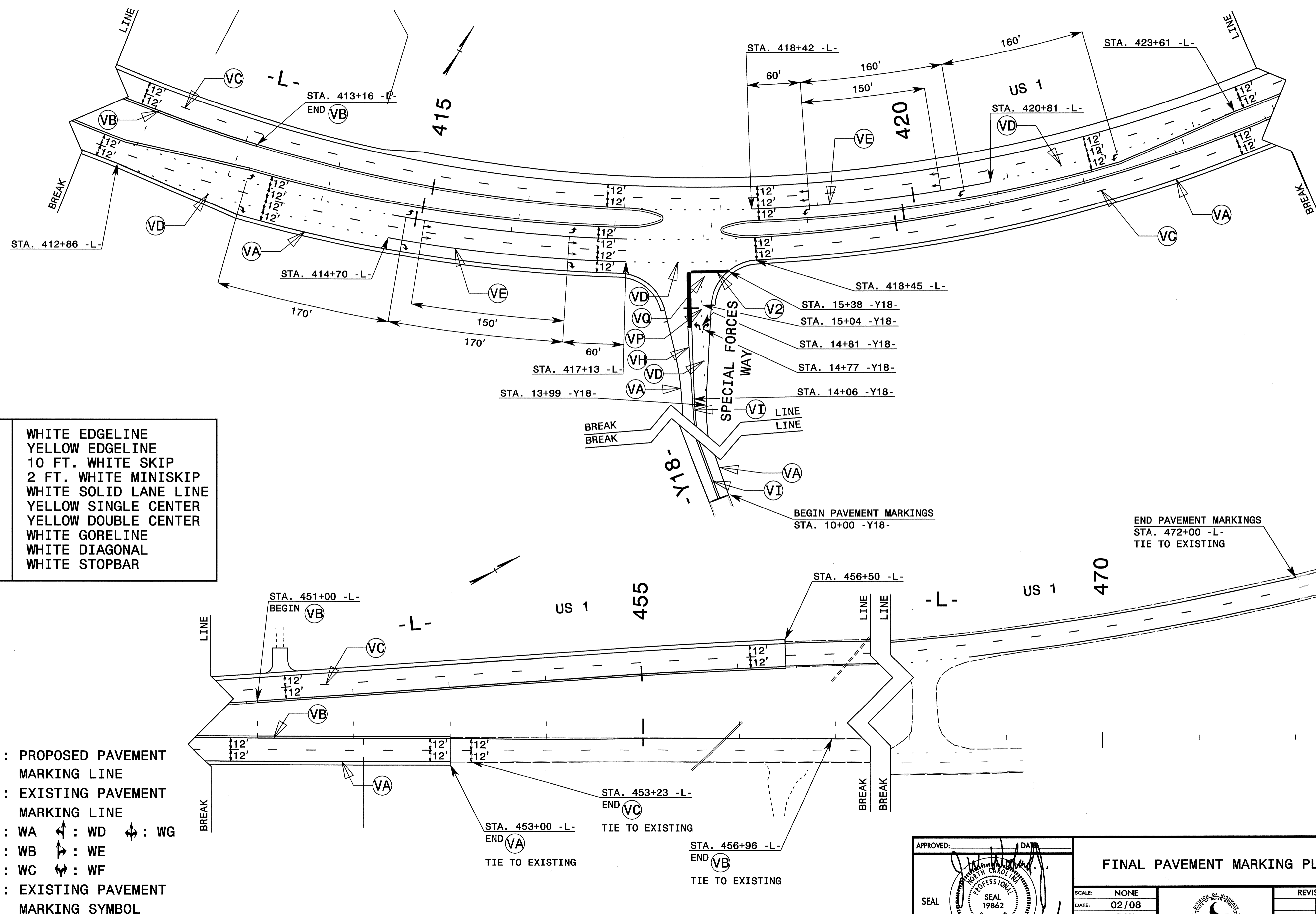

VA	WHITE EDGELINE
VB	YELLOW EDGELINE
VC	10 FT. WHITE SKIP
VD	2 FT. WHITE MINISKIP
VE	WHITE SOLID LANE LINE
VH	YELLOW SINGLE CENTER
VI	YELLOW DOUBLE CENTER
VP	WHITE GORELINE
VQ	WHITE DIAGONAL
V2	WHITE STOPBAR

- : PROPOSED PAVEMENT MARKING LINE
- - - : EXISTING PAVEMENT MARKING LINE
- ↔ : WA ↔ : WD ↔ : WG
- ↔ : WB ↔ : WE
- ↔ : WC ↔ : WF
- ↔ : EXISTING PAVEMENT MARKING SYMBOL

APPROVED: _____ DATE: _____	FINAL PAVEMENT MARKING PLAN	
SEAL		
	SCALE: NONE	
	DATE: 02/08	
	DWG. BY: DAH	
	DESIGN BY: DAH	
REVIEWED BY: JWW	REVISIONS	

19-FEB-2008 09:09
 \\dot\dfs\0010\Pro\IP\Projects-R\2502B\Traffic\TrafficControl\Top\pmp\YR-2502b_tc_pmp_05.dgn
 ahays AT WZTC24241