

STATE OF NORTH CAROLINA
DIVISION OF HIGHWAYS

STATE PROJECT REFERENCE NO.	SHEET NO.
R-2502A	TCP-1

**PLAN FOR PROPOSED
TRAFFIC CONTROL, MARKING & DELINEATION**

RICHMOND COUNTY

R-2502A

ROADWAY STANDARD DRAWINGS

THE FOLLOWING ROADWAY STANDARDS AS APPEAR IN "ROADWAY STANDARD DRAWINGS" - PROJECT SERVICES UNIT-N.C. DEPARTMENT OF TRANSPORTATION-RALEIGH, N.C., DATED JULY 2006 ARE APPLICABLE TO THIS PROJECT AND BY REFERENCE HEREBY ARE CONSIDERED A PART OF THESE PLANS:

STD. NO.	TITLE
1101.02	TEMPORARY LANE CLOSURES
1101.03	TEMPORARY ROAD CLOSURES
1101.05	WORK ZONE VEHICLE ACCESSES
1101.11	TRAFFIC CONTROL DESIGN TABLES
1110.01	STATIONARY WORK ZONE SIGNS
1110.02	PORTABLE WORK ZONE SIGNS
1115.01	FLASHING ARROW PANELS
1130.01	DRUM
1135.01	CONES
1145.01	BARRICADES
1150.01	FLAGGING DEVICES
1160.01	TEMPORARY CRASH CUSHION
1165.01	TRUCK MOUNTED IMPACT ATTENUATOR
1170.01	PORTABLE CONCRETE BARRIER
1180.01	SKINNY-DRUM
1205.01	PAVEMENT MARKINGS - LINE TYPES & OFFSETS
1205.02	PAVEMENT MARKINGS - 2 LANE & MULTILANE ROADWAYS
1205.04	PAVEMENT MARKINGS - INTERSECTIONS
1205.05	PAVEMENT MARKINGS - TURN LANES
1205.06	PAVEMENT MARKINGS - THRU LANE DROPS
1205.08	PAVEMENT MARKINGS - SYMBOLS & WORD MESSAGES
1205.11	PAVEMENT MARKINGS - RAILROAD CROSSINGS
1250.01	PAVEMENT MARKER SPACING
1251.01	RAISED PAVEMENT MARKERS (TEMPORARY)
1253.01	SNOWPLOWABLE RAISED PAVEMENT MARKERS
1261.01	GUARDRAIL & BARRIER DELINEATOR SPACING
1261.02	GUARDRAIL & BARRIER DELINEATOR TYPES
1262.01	GUARDRAIL END DELINEATION

INDEX OF SHEETS

SHEET NO.	TITLE
TCP-1	LIST OF APPLICABLE ROADWAY STANDARD DRAWINGS, LEGEND AND INDEX OF SHEETS
TCP-2 THRU 2A	PROJECT NOTES
TCP-3	PHASING
TCP-4	TEMPORARY SHORING DATA AND TEMPORARY PAVEMENT MARKING SCHEDULE
TCP-4A	PORTABLE CONCRETE BARRIER AT TEMPORARY SHORING LOCATIONS
TCP-5 THRU 17A	PHASE I DETAIL
TCP-18 THRU 28	PHASE II DETAIL
TCP-28A	TRAFFIC CONTROL FOR NEW STOP LOCATION FOR -Y- LINES
TCP-29 THRU 37	PHASE III DETAIL
TCP-38	DETAIL DRAWING FOR TWO-WAY UNDIVIDED AND URBAN FREEWAYS ADVANCED WORK ZONE WARNING SIGNS
PM-1	FINAL PAVEMENT MARKING SCHEDULE
PM-2 THRU 7	FINAL PAVEMENT MARKING PLAN
SD-1	SPECIAL SIGN DESIGN

LEGEND

- GENERAL**
- DIRECTION OF TRAFFIC FLOW
 - NORTH ARROW
 - PROPOSED PVMT. EXIST. PVMT.
 - WORK AREA
 - REMOVAL OF EXISTING PAVEMENT
- TRAFFIC CONTROL DEVICES**
- TYPE III BARRICADE
 - CONE
 - DRUM SKINNY DRUM
 - FLASHING ARROW PANEL (TYPE C)
 - STATIONARY SIGN
 - PORTABLE SIGN
 - CRASH CUSHION
 - CHANGEABLE MESSAGE SIGN
 - TRUCK MOUNTED IMPACT ATTENUATOR (TMIA)
 - POLICE
 - FLAGGER
- PAVEMENT MARKINGS**
- YELLOW/YELLOW PAVEMENT MARKER
 - CRYSTAL/RED PAVEMENT MARKER
 - PAVEMENT MARKING SYMBOLS

TIP PROJECT:

19-FEB-2008 09:59 \\dot\dfsroot\Pro\TIP\Projects-R\2502A\TrafficControl\Toc\Phase I\R-2502A_TC_Tcp_Phil_Ol_Tile.dgn AT WZTC22424

APPROVED: _____ DATE: _____	PLAN PREPARED BY: N.C.D.O.T. WORK ZONE TRAFFIC CONTROL UNIT
SEAL	J. S. BOURNE, P.E. TRAFFIC CONTROL ENGINEER
	G. L. GETTIER, P.E. TRAFFIC CONTROL PROJECT ENGINEER
	J. W. WOOLARD, P.E. TRAFFIC CONTROL PROJECT DESIGN ENGINEER
	D. A. HAYES, E.I. TRAFFIC CONTROL DESIGN ENGINEER / TECHNICIAN

GENERAL NOTES

CHANGES MAY BE REQUIRED WHEN PHYSICAL DIMENSIONS IN THE DETAIL DRAWINGS, STANDARD DETAILS AND ROADWAY DETAILS ARE NOT ATTAINABLE TO MEET FIELD CONDITIONS, OR RESULT IN DUPLICATE, OR UNDESIRE OVERLAPPING OF DEVICES. MODIFICATION MAY INCLUDE: MOVING, SUPPLEMENTING, COVERING OR REMOVAL OF DEVICES, AS DIRECTED BY THE ENGINEER.

THE FOLLOWING GENERAL NOTES APPLY AT ALL TIMES FOR THE DURATION OF THE CONSTRUCTION PROJECT, EXCEPT WHEN OTHERWISE NOTED IN THE PLAN, OR DIRECTED BY THE ENGINEER.

TIME RESTRICTIONS

- A) DO NOT CLOSE OR NARROW TRAVEL LANES DURING HOLIDAYS AND SPECIAL EVENTS AS FOLLOWS:

ROAD NAME

- L- (US 1)
- ALL -Y- LINES

HOLIDAY

- FOR ANY UNEXPECTED OCCURRENCE THAT CREATES UNUSUALLY HIGH TRAFFIC VOLUMES, AS DIRECTED BY THE ENGINEER.
- FOR NEW YEAR'S, BETWEEN THE HOURS OF 8:00 A.M. DECEMBER 31st TO 6:00 P.M. JANUARY 2ND. IF NEW YEAR'S DAY IS ON A FRIDAY, SATURDAY, SUNDAY, OR MONDAY THEN UNTIL 6:00 P.M. THE FOLLOWING TUESDAY.
- FOR EASTER, BETWEEN THE HOURS OF 8:00 A.M. THURSDAY AND 6:00 P.M. MONDAY.
- FOR MEMORIAL DAY, BETWEEN THE HOURS OF 8:00 A.M. FRIDAY TO 6:00 P.M. TUESDAY.
- FOR INDEPENDENCE DAY, BETWEEN THE HOURS OF 8:00 A.M. THE DAY BEFORE INDEPENDENCE DAY AND 6:00 P.M. THE DAY AFTER INDEPENDENCE DAY.

IF INDEPENDENCE DAY IS ON A FRIDAY, SATURDAY, SUNDAY OR MONDAY THEN BETWEEN THE HOURS OF 8:00 A.M. THE THURSDAY BEFORE INDEPENDENCE DAY AND 6:00 P.M. THE TUESDAY AFTER INDEPENDENCE DAY.
- FOR LABOR DAY, BETWEEN THE HOURS OF 8:00 A.M. FRIDAY AND 6:00 P.M. TUESDAY.
- FOR THANKSGIVING DAY, BETWEEN THE HOURS OF 8:00 A.M. TUESDAY TO 6:00 P.M. MONDAY.
- FOR CHRISTMAS, BETWEEN THE HOURS OF 8:00 A.M. THE FRIDAY BEFORE THE WEEK OF CHRISTMAS DAY AND 6:00 P.M. THE FOLLOWING TUESDAY AFTER THE WEEK OF CHRISTMAS.

- B) DO NOT STOP TRAFFIC AS FOLLOWS:

ROAD NAME	RESTRICTIONS	OPERATION
1. -L- (US 1)	15 MINUTES	TRAFFIC SHIFTS

- C) DO NOT CONDUCT ANY HAULING OPERATIONS AGAINST THE FLOW OF TRAFFIC OF AN OPEN TRAVELWAY UNLESS THE WORK AREA IS PROTECTED BY BARRIER OR GUARDRAIL OR OTHERWISE DIRECTED BY THE ENGINEER.

LANE AND SHOULDER CLOSURE REQUIREMENTS

- D) REMOVE LANE CLOSURE DEVICES FROM THE LANE WHEN WORK IS NOT BEING PERFORMED BEHIND THE LANE CLOSURE OR WHEN A LANE CLOSURE IS NO LONGER NEEDED, OR AS DIRECTED BY THE ENGINEER.
- E) WHEN PERSONNEL AND/OR EQUIPMENT ARE WORKING WITHIN 15 FT OF AN OPEN TRAVEL LANE, CLOSE THE NEAREST OPEN SHOULDER USING ROADWAY STANDARD DRAWING NO. 1101.04 UNLESS THE WORK AREA IS PROTECTED BY BARRIER OR GUARDRAIL.

- F) WHEN PERSONNEL AND/OR EQUIPMENT ARE WORKING ON THE SHOULDER ADJACENT TO AN UNDIVIDED FACILITY AND WITHIN 5 FT OF AN OPEN TRAVEL LANE, CLOSE THE NEAREST OPEN TRAVEL LANE USING ROADWAY STANDARD DRAWING NO. 1101.02 UNLESS THE WORK AREA IS PROTECTED BY BARRIER OR GUARDRAIL.

WHEN PERSONNEL AND/OR EQUIPMENT ARE WORKING ON THE SHOULDER ADJACENT TO A DIVIDED FACILITY AND WITHIN 10 FT OF AN OPEN TRAVEL LANE, CLOSE THE NEAREST OPEN TRAVEL LANE USING ROADWAY STANDARD DRAWING NO. 1101.02 UNLESS THE WORK AREA IS PROTECTED BY BARRIER OR GUARDRAIL.

- G) WHEN PERSONNEL AND/OR EQUIPMENT ARE WORKING WITHIN A LANE OF TRAVEL OF AN UNDIVIDED OR DIVIDED FACILITY, CLOSE THE LANE ACCORDING TO THE TRAFFIC CONTROL PLANS, ROADWAY STANDARD DRAWINGS OR AS DIRECTED BY THE ENGINEER. CONDUCT THE WORK SO THAT ALL PERSONNEL AND/OR EQUIPMENT REMAIN WITHIN THE CLOSED TRAVEL LANE.

- H) DO NOT WORK SIMULTANEOUSLY WITHIN 15 FT ON BOTH SIDES OF AN OPEN TRAVELWAY, RAMP OR LOOP WITHIN THE SAME LOCATION UNLESS PROTECTED WITH GUARDRAIL OR BARRIER.

- I) DO NOT INSTALL MORE THAN 1 MILE OF LANE CLOSURE ON -L- (US 1) MEASURED FROM THE BEGINNING OF THE MERGE TAPER TO THE END OF THE LANE CLOSURE.

- J) DO NOT INSTALL MORE THAN TWO (2) SIMULTANEOUS LANE CLOSURES, IN ANY ONE DIRECTION, ON -L- (US 1).

- K) PROVIDE A MINIMUM OF 1 MILE BETWEEN LANE CLOSURES, MEASURED FROM THE END OF ONE CLOSURE TO THE FIRST SIGN OF THE NEXT LANE CLOSURE.

- L) PROVIDE TRAFFIC CONTROL FOR APPROPRIATE LANE CLOSURES FOR SURVEYING DONE BY THE DEPARTMENT.

PAVEMENT EDGE DROP OFF REQUIREMENTS

- M) BACKFILL AT A 6:1 SLOPE UP TO THE EDGE AND ELEVATION OF EXISTING PAVEMENT IN AREAS ADJACENT TO AN OPENED TRAVEL LANE THAT HAS A DROP-OFF AS FOLLOWS:

BACKFILL DROP-OFFS THAT EXCEED 2 INCHES ON ROADWAYS WITH POSTED SPEED LIMITS OF 45 MPH OR GREATER.

BACKFILL DROP-OFFS THAT EXCEED 3 INCHES ON ROADWAYS WITH POSTED SPEED LIMITS LESS THAN 45 MPH.

BACKFILL WITH SUITABLE COMPACTED MATERIAL, AS APPROVED BY THE ENGINEER, AT NO EXPENSE TO THE DEPARTMENT.

- N) DO NOT EXCEED A DIFFERENCE OF 2 INCHES IN ELEVATION BETWEEN OPEN LANES OF TRAFFIC FOR NOMINAL LIFTS OF 1.5 INCHES. INSTALL ADVANCE WARNING "UNEVEN LANES" SIGNS (W8-11) 500 FT IN ADVANCE AND A MINIMUM OF EVERY HALF MILE THROUGHOUT THE UNEVEN AREA.

TRAFFIC PATTERN ALTERATIONS

- O) NOTIFY THE ENGINEER TWENTY ONE (21) CALENDAR DAYS PRIOR TO ANY TRAFFIC PATTERN ALTERATION.

SIGNING

- P) INSTALL ADVANCE WORK ZONE WARNING SIGNS WHEN WORK IS WITHIN 40 FT FROM THE EDGE OF TRAVEL LANE AND NO MORE THAN THREE (3) DAYS PRIOR TO THE BEGINNING OF CONSTRUCTION.

- Q) PROVIDE PERMANENT SIGNING.

- R) PROVIDE DETOUR SIGNING WITHIN AND OFF THE PROJECT LIMITS.

- S) THE CONTRACTOR WILL COVER OR REMOVE ALL DETOUR SIGNS WITHIN AND OFF THE PROJECT LIMITS WHEN A DETOUR IS NOT IN OPERATION.

- T) ENSURE ALL NECESSARY SIGNING IS IN PLACE PRIOR TO ALTERING ANY TRAFFIC PATTERN.

- U) INSTALL BLACK ON ORANGE "DIP" SIGNS (W8-2) AND/OR "BUMP" SIGNS (W8-1) 500 FT IN ADVANCE OF THE UNEVEN AREA, OR AS DIRECTED BY THE ENGINEER.

TRAFFIC BARRIER

- V) INSTALL TEMPORARY BARRIER ACCORDING TO THE TRAFFIC CONTROL PLANS A MAXIMUM OF TWO (2) WEEKS PRIOR TO BEGINNING WORK IN ANY LOCATION. ONCE TEMPORARY BARRIER IS INSTALLED AT ANY LOCATION, PROCEED IN A CONTINUOUS MANNER TO COMPLETE THE PROPOSED WORK IN THAT LOCATION UNLESS OTHERWISE STATED IN THE TRAFFIC CONTROL PLANS OR AS DIRECTED BY THE ENGINEER.

DO NOT PLACE BARRIER DIRECTLY ON ANY SURFACE OTHER THAN ASPHALT OR CONCRETE.

ONCE TEMPORARY BARRIER IS INSTALLED AT ANY LOCATION AND NO WORK IS PERFORMED BEHIND THE TEMPORARY BARRIER FOR A PERIOD LONGER THAN TWO (2) MONTHS, REMOVE/RESET TEMPORARY BARRIER AT NO COST TO THE DEPARTMENT UNLESS OTHERWISE STATED IN THE TRAFFIC CONTROL PLANS, TEMPORARY BARRIER IS PROTECTING A HAZARD, OR AS DIRECTED BY THE ENGINEER.

INSTALL TEMPORARY BARRIER WITH THE TRAFFIC FLOW, BEGINNING WITH THE UPSTREAM SIDE OF TRAFFIC. REMOVE TEMPORARY BARRIER AGAINST THE TRAFFIC FLOW, BEGINNING WITH THE DOWNSTREAM SIDE OF TRAFFIC.

INSTALL AND SPACE DRUMS NO GREATER THAN TWICE THE POSTED SPEED LIMIT (MPH) TO CLOSE OR KEEP THE SECTION OF THE ROADWAY CLOSED UNTIL THE TEMPORARY BARRIER CAN BE PLACED OR AFTER THE TEMPORARY BARRIER IS REMOVED.

- W) PROTECT THE APPROACH END OF MOVABLE/PORTABLE CONCRETE BARRIER AT ALL TIMES DURING THE INSTALLATION AND REMOVAL OF THE BARRIER BY EITHER A TRUCK MOUNTED IMPACT ATTENUATOR (MAXIMUM 72 HOURS) OR A TEMPORARY CRASH CUSHION.

PROTECT THE APPROACH END OF MOVABLE/PORTABLE CONCRETE BARRIER FROM ONCOMING TRAFFIC AT ALL TIMES BY A TEMPORARY CRASH CUSHION UNLESS THE APPROACH END OF MOVABLE/PORTABLE CONCRETE BARRIER IS OFFSET FROM ONCOMING TRAFFIC AS FOLLOWS OR AS SHOWN IN THE PLANS:

POSTED SPEED LIMIT	MINIMUM OFFSET
40 OR LESS	15 FT
45 - 50	20 FT
55	25 FT
60 MPH or HIGHER	30 FT

TRAFFIC CONTROL DEVICES

- X) SPACE CHANNELIZING DEVICES IN WORK AREAS NO GREATER THAN TWICE THE POSTED SPEED LIMIT (MPH), EXCEPT 10 FT ON-CENTER IN RADII, AND 3 FT OFF THE EDGE OF AN OPEN TRAVELWAY, WHEN LANE CLOSURES ARE NOT IN EFFECT. WHEN SKINNY DRUMS ARE ALLOWED, REFER TO SECTION 1180 OF STANDARD SPECIFICATIONS FOR ROADS AND STRUCTURES OR AS SHOWN IN THE PLANS.

- Y) PLACE TYPE III BARRICADES, WITH "ROAD CLOSED" SIGN R11-2 ATTACHED, OF SUFFICIENT LENGTH TO CLOSE ENTIRE ROADWAY.

- Z) PLACE ADDITIONAL SETS OF THREE CHANNELIZING DEVICES PERPENDICULAR TO THE EDGE OF TRAVELWAY ON 500 FT CENTERS WHEN UNOPENED LANES ARE CLOSED TO TRAFFIC.

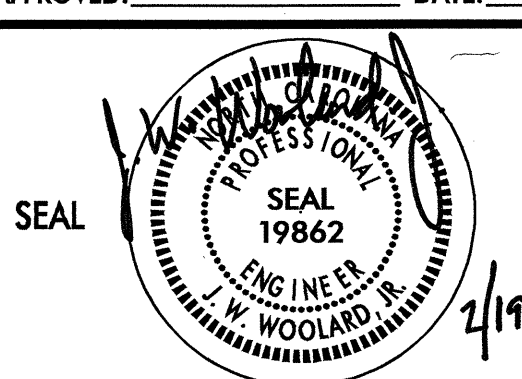
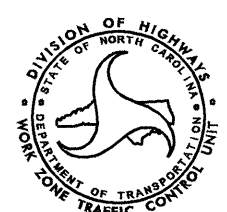
APPROVED: _____	DATE: _____	PROJECT NOTES	
	SCALE: NONE		REVISIONS
	DATE: 02/08		
	DWG. BY: DAH		
	DESIGN BY: DAH		
REVIEWED BY: JWW			CADD FILE

GENERAL NOTES

PAVEMENT MARKINGS AND MARKERS

AA) INSTALL PAVEMENT MARKINGS AND PAVEMENT MARKERS ON THE FINAL SURFACE AS FOLLOWS:

ROAD NAME	MARKING	MARKER
1. -L- (US 1)	POLYUREA	SNOWPLOWABLE
2. ALL -Y- LINES	POLYUREA	SNOWPLOWABLE

BB) INSTALL TEMPORARY PAVEMENT MARKINGS AND TEMPORARY PAVEMENT MARKERS ON INTERIM LAYERS OF PAVEMENT AS FOLLOWS:

ROAD NAME	MARKING	MARKER
1. -L- (US 1)	PAINT	RAISED
2. ALL -Y- LINES	PAINT	RAISED

CC) PLACE ONE APPLICATION OF PAINT FOR TEMPORARY TRAFFIC PATTERNS. PLACE A SECOND APPLICATION OF PAINT SIX (6) MONTHS AFTER THE INITIAL APPLICATION AND EVERY SIX MONTHS AS DIRECTED BY THE ENGINEER.

DD) TIE PROPOSED PAVEMENT MARKING LINES TO EXISTING PAVEMENT MARKING LINES.



EE) REMOVE/REPLACE ANY CONFLICTING/DAMAGED PAVEMENT MARKINGS AND MARKERS BY THE END OF EACH DAY'S OPERATION.

FF) TRACE THE PROPOSED MONOLITHIC ISLAND LOCATIONS WITH PROPER COLOR PAVEMENT MARKINGS PRIOR TO INSTALLATION. PLACE CONES TO DELINEATE ANY PROPOSED MONOLITHIC ISLANDS BEFORE INSTALLATION.

MISCELLANEOUS

GG) IN THE EVENT A TIE-IN CANNOT BE MADE IN ONE DAYS TIME, BRING THE TIE-IN AREA TO AN APPROPRIATE ROADWAY ELEVATION, AS DETERMINED BY THE ENGINEER. PLACE BLACK ON ORANGE "LOOSE GRAVEL" SIGNS (W8-7) AND BLACK ON ORANGE "PAVEMENT ENDS" SIGNS (W8-3) 500 FT AND 500 FT RESPECTIVELY IN ADVANCE OF THE UNEVEN AREAS. USE DRUMS TO DELINEATE THE EDGE OF ROADWAY ALONG UNPAVED AREAS.

I9-FEB-2008 09:59
 \\dot\dfsroot\Pro\TIP\Projects-R\R2502A\TrafficControl\Top\Phase I\T-2502a-rc-top-ph1_02-gennotes.dgn
 dnoves AT WZTC22424

APPROVED: _____	DATE: _____	PROJECT NOTES							
	SCALE: NONE								
	DATE: 02/08								
	DESIGN BY: DAH								
	REVIEWED BY: JWW								
		REVISIONS							
		<table border="1" style="width: 100%;"> <tr> <td style="width: 50%; height: 20px;"></td> <td style="width: 50%;"></td> </tr> <tr> <td style="height: 20px;"></td> <td></td> </tr> <tr> <td style="height: 20px;"></td> <td></td> </tr> </table>							
		<small>CADD FILE</small>							

PHASE I

- STEP 1) INSTALL ALL ADVANCE WORK ZONE SIGNING (SEE TCP-38).
- STEP 2) USING ROADWAY STANDARD DRAWING (RSD) 1101.02, SHEETS 1 & 3 OF 9 INSTALL TEMPORARY PAVEMENT MARKINGS, TEMPORARY MARKERS, AND REMOVE CONFLICTING EXISTING MARKINGS FROM STA. 1+53 -L- TO STA. 277+87 -L-. SHIFT TRAFFIC ONTO THE TEMPORARY TRAFFIC PATTERN (SEE TCP-5 THRU 16).

PHASE I, STEP 3 AND 3A ARE TO BE BEGUN SIMULTANEOUSLY.

- STEP 3) USING RSD 1101.02, SHEET 1 OF 9 AS NEEDED, BEGIN CONSTRUCTION OF THE FOLLOWING UP TO BUT NOT INCLUDING THE FINAL LIFT OF SURFACE COURSE (SEE TCP-5 THRU 15):
- -L- LEFT FROM STA. 2+80 -L- TO STA. 24+86 -L-
 - -L- LEFT FROM STA. 26+16 -L- TO STA. 33+68 -L-
 - -L- LEFT FROM STA. 34+98 -L- TO STA. 55+23 -L-
 - -L- RIGHT FROM STA. 132+00 -L- TO STA. 181+02 -L- (WEDGE PAVEMENT FROM EDGE AND ELEVATION AT STA. 132+00 -L- TO UP TO BUT NOT INCLUDING THE FINAL LIFT OF SURFACE COURSE AT STA. 133+00 -L-)
 - -L- LEFT FROM STA. 174+14 -L- TO STA. 185+67 -L-
 - -L- LEFT FROM STA. 187+00 -L- TO STA. 236+62 -L-
 - -L- LEFT FROM STA. 237+78 -L- TO STA. 271+46 -L-

USING RSD 1101.02, SHEET 1 OF 9, INSTALL PORTABLE CONCRETE BARRIER (PCB) FROM STA. 13+24 -Y15- TO STA. 277+87 -L-. INSTALL TEMPORARY SHORING FROM STA. 272+21 -L- TO STA. 277+00 -L- AND BEGIN CONSTRUCTION OF -L- LEFT FROM STA. 272+21 -L- TO STA. 289+49 +/- -L- (SEE TCP-15 & 16).

BEHIND DRUMS CONSTRUCT THE MODIFIED PAVEMENT DESIGN (SEE CONSTRUCTION PLANS, TYPICAL SECTION 1B) ON THE RIGHT SIDE OF -L- AT THE FOLLOWING LOCATIONS (SEE TCP-7 THRU 9):

- STA. 58+57 -L- TO STA. 95+84 -L-
- STA. 113+35 -L- TO STA. 132+00 -L-

USING RSD 1101.02, SHEET 1 OF 9, WIDEN THE FOLLOWING UP TO EXISTING EDGE AND ELEVATION (SEE TCP-11 THRU 13):

- -Y8- FROM STA. 11+83 -Y8- TO STA. 13+50 -Y8-
- -Y8- LEFT FROM STA. 13+50 -Y8- TO -L-
- -Y9- FROM STA. 11+46 -Y9- TO -L-
- -Y11- FROM STA. 11+00 -Y11- TO -L-
- -Y12- FROM STA. 11+50 -Y12- TO -L-

AWAY FROM TRAFFIC CONSTRUCT -Y8- RIGHT FROM STA. 13+50 -Y8- TO STA. 14+00 -Y8-, AND -Y8- FROM STA. 14+00 -Y8- TO -L- UP TO BUT NOT INCLUDING THE FINAL LIFT OF SURFACE COURSE.

USING DRUMS, TYPE III BARRICADES, AND DETOUR SIGNING, CLOSE -Y14-, DETOUR TRAFFIC OFFSITE, AND WORKING IN A CONTINUOUS MANNER CONSTRUCT -Y14- UP TO BUT NOT INCLUDING THE FINAL LIFT OF SURFACE COURSE. OPEN -Y14- TO TRAFFIC, REMOVE -Y14- DETOUR SIGNING, INSTALL -Y15- AND -Y16- DETOUR SIGNING, AND DETOUR TRAFFIC OFFSITE. BEGIN CONSTRUCTION OF -Y15- AND CONSTRUCT -Y16- UP TO BUT NOT INCLUDING THE FINAL LIFT OF SURFACE COURSE. OPEN -Y16- TO TRAFFIC AND REMOVE -Y16- DETOUR SIGNING (SEE TCP-14 THRU 17).

PHASE I, STEP 3A IS TO BE COMPLETED IN 30 MANDAYS. SEE SPECIAL PROVISIONS FOR LIQUIDATED DAMAGES.

- STEP 3A) USING DRUMS, TYPE III BARRICADES, AND OFFSITE DETOUR SIGNING, CLOSE -Y1- AND -Y3- AND DETOUR TRAFFIC OFFSITE. AWAY FROM TRAFFIC AND WORKING IN A CONTINUOUS MANNER, CONSTRUCT -Y1- AND -Y3- UP TO BUT NOT INCLUDING THE FINAL LIFT OF SURFACE COURSE (SEE TCP-5 & 17). UPON COMPLETION, OPEN -Y1- AND -Y3- TO TRAFFIC AND REMOVE OFFSITE DETOUR SIGNING (SEE TCP-18).
- STEP 4) USING RSD 1101.02, SHEET 1 OF 9 AS NEEDED, COMPLETE CONSTRUCTION OF THE FOLLOWING UP TO BUT NOT INCLUDING THE FINAL LIFT OF SURFACE COURSE (SEE TCP-18, 22 & 24 THRU 27):
- -L- LEFT FROM STA. 20+78 -L- TO STA. 21+69 -L-
 - -L- LEFT FROM STA. 29+43 -L- TO STA. 30+34 -L-
 - -L- RIGHT FROM STA. 132+00 -L- TO STA. 180+30 -L-
 - -L- LEFT FROM STA. 184+55 -L- TO STA. 185+67 -L-
 - -L- LEFT FROM STA. 237+78 -L- TO STA. 238+85 -L-
 - -L- LEFT FROM STA. 260+80 -L- TO STA. 261+85 -L-
 - -L- LEFT FROM STA. 283+67 -L- TO STA. 284+57 -L-
 - -Y8- RIGHT FROM STA. 11+83 -Y8- TO -L-, WEDGING UP TO BUT NOT INCLUDING THE FINAL LIFT OF SURFACE COURSE FROM STA. 11+83 -Y8- TO STA 13+50 -Y8-

PHASE II

- STEP 1) USING RSD 1101.02, SHEET 1 OF 9, REMOVE PAVEMENT MARKINGS AND MARKERS AND REPLACE FROM STA. 58+44 -L- TO 180+30 -L-, SHIFT TRAFFIC ONTO TEMPORARY TRAFFIC PATTERN, AND INSTALL DRUMS ACCORDING TO PHASE II DETAIL DRAWINGS (SEE TCP-19 THRU 24).
- OPEN -Y14-, AND -Y16- TO TRAFFIC AND REMOVE OFFSITE DETOUR SIGNING (SEE TCP-26 & 27).

BEGIN PHASE II, STEP 2, STEP 2A, AND STEP 2B SIMULTANEOUSLY. COMPLETE PHASE II, STEP 2 AND STEP 2C SIMULTANEOUSLY.

- STEP 2) USING RSD 1101.02, SHEET 1 OF 9 AS NEEDED, CONSTRUCT THE FOLLOWING UP TO BUT NOT INCLUDING THE FINAL LIFT OF SURFACE COURSE (SEE TCP-18 THRU 24):
- -L- LEFT FROM STA. 24+86 -L- TO STA. 26+16 -L-
 - -L- LEFT FROM STA. 33+68 -L- TO STA. 34+98 -L-
 - -L- LEFT FROM STA. 55+23 -L- TO STA. 180+30 -L-
 - -L- LEFT FROM STA. 185+67 -L- TO STA. 187+00 -L-
 - -L- LEFT FROM STA. 236+62 -L- TO STA. 237+78 -L-

USING RSD 1101.02, SHEET 1 OF 9 AS NEEDED, COMPLETE CONSTRUCTION OF THE FOLLOWING UP TO BUT NOT INCLUDING THE FINAL LIFT OF SURFACE COURSE (SEE TCP-5, 18, 19, 24 THRU 27):

- -L- LEFT FROM STA. 3+00 -L- TO STA. 20+78 -L-
- -L- LEFT FROM STA. 21+69 -L- TO STA. 24+86 -L-
- -L- LEFT FROM STA. 26+16 -L- TO STA. 29+43 -L-
- -L- LEFT FROM STA. 30+34 -L- TO STA. 33+68 -L-
- -L- LEFT FROM STA. 34+98 -L- TO STA. 55+23 -L-
- -L- LEFT FROM STA. 174+14 -L- TO STA. 184+55 -L-
- -L- LEFT FROM STA. 187+00 -L- TO STA. 236+62 -L-
- -L- LEFT FROM STA. 237+78 -L- TO STA. 260+80 -L-
- -L- LEFT FROM STA. 261+85 -L- TO STA. 271+36 -L-
- -L- LEFT FROM STA. 272+21 -L- TO STA. 283+67 -L-
- -L- LEFT FROM STA. 284+57 -L- TO STA. 289+49 -L-

USING RSD 1101.02, SHEET 1 OF 9 AS NEEDED, SHIFT -Y8- RIGHT TRAFFIC ONTO -Y8-, CONSTRUCT -Y8- LEFT UP TO BUT NOT INCLUDING THE FINAL LIFT OF SURFACE COURSE FROM STA. 13+50 -Y8- TO -L-, WEDGE -Y8- LEFT FROM STA. 11+80 -Y8- TO STA. 13+50 -Y8-, AND SHIFT -Y8- LEFT TRAFFIC ONTO -Y8- (SEE TCP-24 & CUTSECTION Z-Z').

AWAY FROM TRAFFIC CONSTRUCT -Y8- LEFT SHOULDER AND REMOVE EXISTING -Y8- AND -Y12- AND INSTALL TEMPORARY PAVEMENT MARKINGS AND PAVEMENT MARKERS (SEE TCP-24 & 25).

USING BARRICADES CLOSE EXISTING -Y5- TO THRU TRAFFIC AND CONSTRUCT -Y5- UP TO BUT NOT INCLUDING THE FINAL LIFT OF SURFACE COURSE (SEE TCP-27).

PHASE II, STEP 2A IS TO BE COMPLETED IN 30 MANDAYS. SEE SPECIAL PROVISIONS FOR LIQUIDATED DAMAGES.

- STEP 2A) INSTALL OFFSITE DETOUR SIGNING, DETOUR -Y2- AND -Y4- TRAFFIC OFFSITE, AND CLOSE -Y2- AND -Y4- TO TRAFFIC. AWAY FROM TRAFFIC, CONSTRUCT -Y2- AND -Y4- UP TO BUT NOT INCLUDING THE FINAL LIFT OF SURFACE COURSE (SEE TCP-18, 19, & 28). UPON COMPLETION, OPEN -Y2- AND -Y4- TO TRAFFIC, AND REMOVE TRAFFIC CONTROL DEVICES AND OFFSITE DETOUR SIGNING (SEE TCP-31).
- STEP 2B) USING RSD 1101.02, SHEET 1 OF 9, INSTALL TEMPORARY ABC FROM STA. 9+00 -Y7- TO STA. 11+57 -Y7-. SHIFT -Y7- TRAFFIC INTO A ONE LANE, TWO WAY PATTERN AND CONSTRUCT -Y7- RIGHT FROM STA. 10+00 -L- TO STA. 12+60 -Y7- (SEE TCP-22).
- STEP 2C) USING RSD 1101.02, SHEET 1 OF 9 COMPLETE CONSTRUCTION OF -Y7- RIGHT FROM STA. 10+00 -Y7- TO STA. 12+60 -Y7- UP TO BUT NOT INCLUDING THE FINAL LIFT OF SURFACE COURSE. WHEN A SUFFICIENT GRADE OF 4:1 OR FLATTER IS OBTAINED AT THE TIE IN AREA BETWEEN STA. 12+60 -Y7- AND -L-, SWITCH -Y7- TRAFFIC ONTO TEMPORARY PATTERN. CLOSE -Y7- LEFT TO TRAFFIC AND CONSTRUCT -Y7- LEFT FROM STA. 10+00 -Y7- TO -L- UP TO BUT NOT INCLUDING THE FINAL LIFT OF SURFACE COURSE. REMOVE EXISTING -Y7- (SEE TCP-22).

PHASE III

- STEP 1) AWAY FROM TRAFFIC INSTALL TEMPORARY PAVEMENT MARKINGS AND MARKERS FROM -L- LEFT FROM STA. 10+00 -L- TO STA. 289+49 -L- (SEE TCP-29 THRU 37).

REMOVE TRAFFIC CONTROL DEVICES AND DETOUR SIGNING AND OPEN -Y5- TO TRAFFIC (SEE TCP-36).

AWAY FROM TRAFFIC INSTALL PCB ON -L- LEFT FROM STA. 272+21 -L- TO STA. 277+87 -L- (SEE TCP-36).

- STEP 2) USING RSD 1101.02, SHEET 1 OF 9, INSTALL TEMPORARY PAVEMENT MARKINGS AND MARKERS FROM STA. -10+27 -L- TO STA. 10+00 -L-, INSTALL SIGNS AND RUMBLE STRIPS AS SHOWN ON TCP-28A, SHIFT TRAFFIC ONTO TEMPORARY PATTERN, AND CLOSE -L- RIGHT TO TRAFFIC (SEE TCP-29 THRU 37).

REMOVE TRAFFIC CONTROL DEVICES AND DETOUR SIGNING AND OPEN -Y15- TO TRAFFIC (SEE TCP-36).

- STEP 3) USING RSD 1101.02, SHEET 1 OF 9 AS NEEDED, CONSTRUCT THE FOLLOWING UP TO BUT NOT INCLUDING THE FINAL LIFT OF SURFACE COURSE (SEE TCP-29 THRU 37):
- -L- RIGHT FROM STA. 10+00 -L- TO STA. 132+00 -L-
 - -L- RIGHT FROM STA. 181+00 -L- TO STA. 289+49 -L- (REMOVE PCB INSTALLED IN PHASE I)
 - -Y-
 - -Y6-
 - -Y10-
 - -Y13-

USING RSD 1101.02, SHEET 1 OF 9 AS NEEDED, REMOVE EXISTING -Y5- AND DRIVEWAYS AS SHOWN ON TCP-31 AND 36.

AWAY FROM TRAFFIC REMOVE EXISTING -L- FROM STA. 181+00 -L- TO STA 268+00 -L- (SEE TCP-31 THRU 36).

- STEP 4) BEHIND PCB REMOVE TEMPORARY SHORING FROM STA. 272+21 -L- TO STA. 277+00 -L- (SEE TCP-36).
- STEP 5) AWAY FROM TRAFFIC REMOVE PCB FROM STA. 271+95 -L- TO STA. 277+87 -L- (SEE TCP-36).

PHASE IV

- STEP 1) USING RSD 1101.02, SHEET 1 OF 9, COMPLETE CONSTRUCTION OF ALL MEDIAN CURB AND GUTTER SECTIONS AND MONOLITHIC ISLANDS.
- STEP 2) USING RSD 1101.02, SHEET 1 OF 9, INSTALL THE FINAL LIFT OF SURFACE COURSE, FINAL PAVEMENT MARKINGS, AND FINAL PAVEMENT MARKERS ON -Y-, -Y5-, -Y6-, -Y10-, AND -Y13- (SEE PM-2 THRU 6).
- AWAY FROM TRAFFIC, INSTALL THE FINAL LIFT OF SURFACE COURSE, FINAL PAVEMENT MARKINGS, AND FINAL PAVEMENT MARKERS ON -L- RIGHT FROM STA. 10+00 TO STA. 289+49 -L- INCLUDING THE RIGHT LANE LINE OF THE CENTER LEFT TURN LANE (SEE PM-2 THRU 7).
- STEP 3) USING RSD 1101.02, SHEET 1 OF 9, REMOVE LANE MERGE MARKINGS AND MARKERS FROM STA. -10+27 -L- TO STA. 10+00 -L- AND SHIFT -L- EASTBOUND TRAFFIC ONTO -L- RIGHT. INSTALL THE FINAL LIFT OF SURFACE COURSE, FINAL PAVEMENT MARKINGS, AND FINAL PAVEMENT MARKERS ON -L- LEFT FROM STA. 0+70 -L- TO STA. 289+49 -L-, -Y1-, -Y2-, -Y3-, -Y4-, -Y7-, -Y8-, -Y9-, -Y11-, -Y12-, -Y14-, -Y15-, AND -Y16- (SEE PM-2 THRU 7).
- STEP 4) REMOVE ALL TRAFFIC CONTROL DEVICES, SHIFT ALL TRAFFIC INTO FINAL PATTERNS, AND REMOVE ALL ADVANCE WORK ZONE SIGNING.

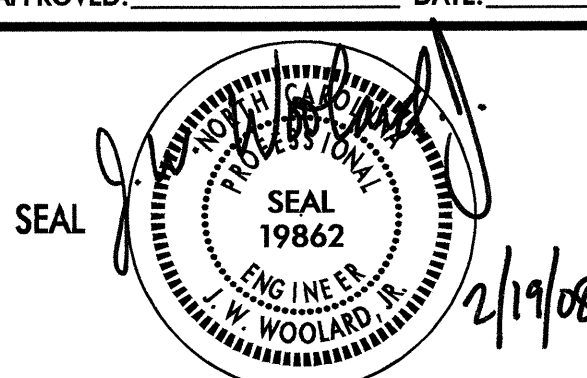
APPROVED: _____ DATE: _____	PHASING	
	SCALE: NONE	REVISIONS
	DATE: 02/08	
	DWG. BY: DAH	
	DESIGN BY: DAH	
	REVIEWED BY: JWW	

19-FEB-2008 09:58
 \\dot\dfsroot\proj\TIPProjects\RR2502A\Traffic\TrafficControl\TopPhase\IR-2502A_TC_PHL03_Phasing.dgn
 ahayes AT WZT22424

TEMPORARY SHORING DATA

Temporary Shoring No. ① (SEE SHEET TCP-15)

FOR TEMPORARY SHORING, SEE TEMPORARY SHORING SPECIAL PROVISION.

FOR CONTRACTOR DESIGNED SHORING, SURVEY THE SHORING LOCATION TO DETERMINE EXISTING ELEVATIONS AND ACTUAL DESIGN HEIGHTS BEFORE BEGINNING DESIGN.

WHEN USING CONTRACTOR DESIGNED SHORING FROM STATION 271+36.00* -L-, 18.5 FT. RIGHT OF EXISTING US 1 SB CENTERLINE MARKING, TO STATION 277+00.00* -L-, 18.5 FT. RIGHT OF EXISTING US 1 SB CENTERLINE MARKING, USE THE FOLLOWING SOIL PARAMETERS:

UNIT WEIGHT OF SOIL ABOVE WATER TABLE, $g = 120$ PCF
 UNIT WEIGHT OF SOIL BELOW WATER TABLE, $g = 60$ PCF
 FRICTION ANGLE, $f = 30$ DEGREES
 COHESION, $c = 0$ PSF

NO SUBSURFACE INFORMATION IS AVAILABLE IN THE VICINITY OF THE TEMPORARY SHORING FROM STATION 271+36.00* -L-, 18.5 FT. RIGHT OF EXISTING US 1 SB CENTERLINE MARKING, TO STATION 277+00.00* -L-, 18.5 FT. RIGHT OF EXISTING US 1 SB CENTERLINE MARKING. THE INFORMATION PROVIDED FOR DESIGN WAS ASSUMED AND MAY NOT BE APPLICABLE TO THE ACTUAL SITE CONDITIONS ENCOUNTERED DURING CONSTRUCTION.

FOR PORTABLE CONCRETE BARRIERS ABOVE AND BEHIND TEMPORARY SHORING, USE AN NCDOT PORTABLE CONCRETE BARRIER (UNANCHORED OR ANCHORED) OR AN OREGON TALL F-SHAPE CONCRETE BARRIER IN ACCORDANCE WITH THE TRAFFIC CONTROL PLANS.



TEMPORARY PAVEMENT MARKING SCHEDULE

SYMBOL	DESCRIPTION
TEMPORARY PAVEMENT MARKINGS	
PAINT(4")	
PA	WHITE EDGELINE (2X)
PD	2 FT. WHITE MINISKIP (2X)
PH	YELLOW SINGLE CENTER (2X)
PI	YELLOW DOUBLE CENTER (2X)
PAINTMARKING SYMBOLS	
QA	LEFT TURN ARROW (2X)
QB	RIGHT TURN ARROW (2X)
QC	STRAIGHT ARROW (2X)
QD	COMBO.STRAIGHT/LEFT (2X)
THERMOPLASTIC(4", 120 MILS)	
WHITE SOLID LANE LINE	
MARKERS	
TEMPORARY RAISED PAVEMENT MARKERS	
MH	YELLOW & YELLOW
MI	CRYSTAL & RED

19-FEB-2008 09:58 \\dot\dfsroot\01\Proj\TIPProjects\R2502A\TrafficControl\Phase 1\NR-2502A_TC_TCP_PHL_04_TempPMSched.dgn ahayes AT W27C22424

NOTE: THE TEMPORARY SHORING NOTES SHOWN ON THIS SHEET WERE PROVIDED THROUGH A SEALED DOCUMENT FROM THE GEOTECHNICAL ENGINEERING UNIT. THE DOCUMENT WAS SUBMITTED TO THE WZTCU ON NOVEMBER 19, 2007 AND SEALED BY A PROFESSIONAL ENGINEER, JOHN L. PILIPCHUK, LICENSE #25521.

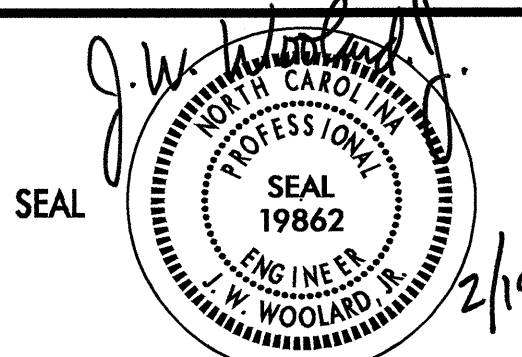
NOTE: ALL DIMENSIONS AND STATIONS +/-

APPROVED: _____	DATE: _____	TEMPORARY SHORING DATA AND TEMPORARY PAVEMENT MARKING SCHEDULE							
	SCALE: NONE								
	DATE: 02/08								
	DWG. BY: DAH								
	DESIGN BY: DAH								
REVIEWED BY: JWW		<table border="1" style="width: 100%; border-collapse: collapse;"> <tr> <th colspan="2">REVISIONS</th> </tr> <tr> <td style="width: 50%;"> </td> <td style="width: 50%;"> </td> </tr> <tr> <td> </td> <td> </td> </tr> </table>		REVISIONS					
REVISIONS									

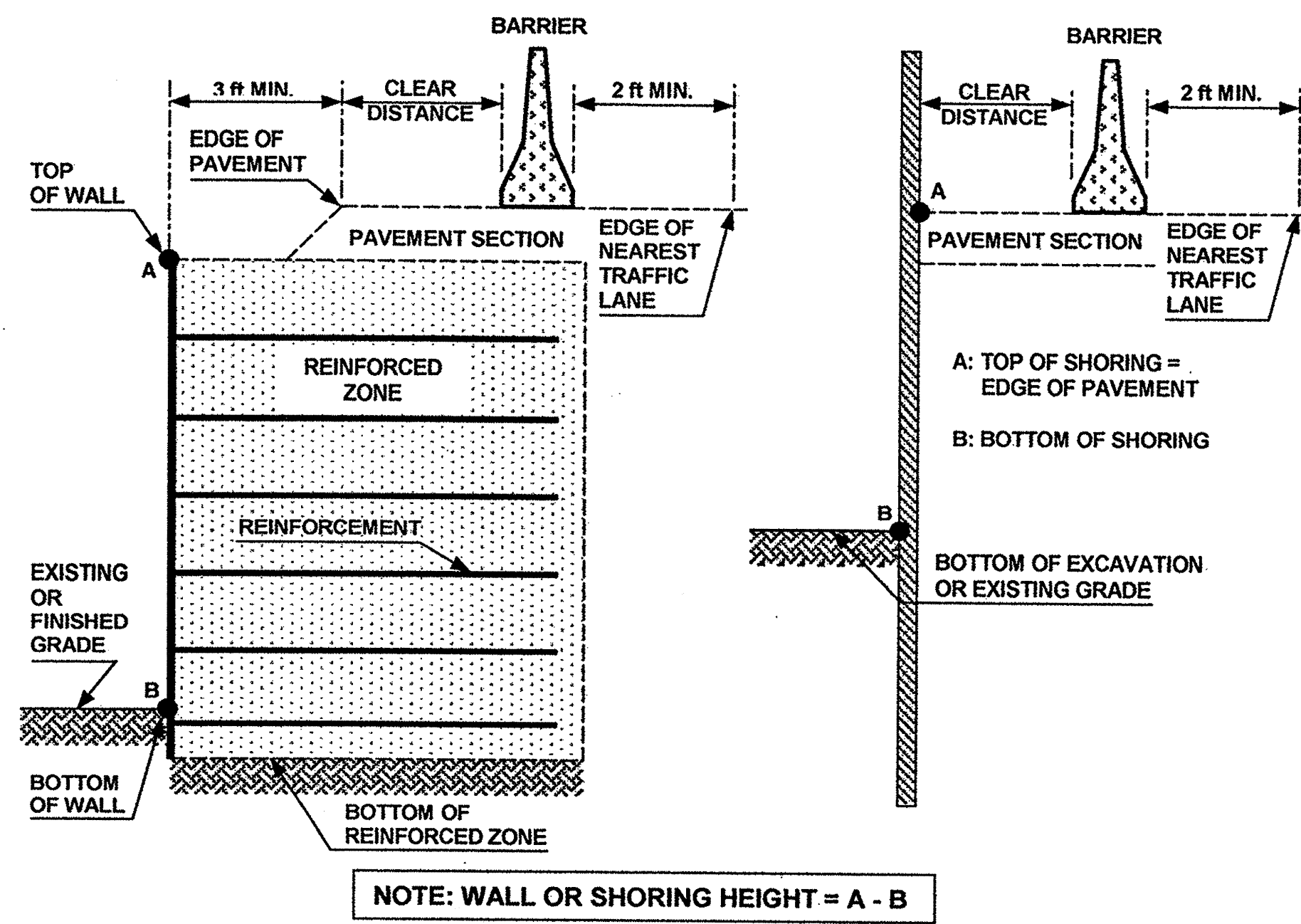

FIGURE A

NOTES

- REFER TO THE TRAFFIC CONTROL PLANS FOR SHORING LOCATIONS AND SOIL PARAMETERS.
- REFER TO THE "TEMPORARY SHORING" PROJECT SPECIAL PROVISION FOR MORE INFORMATION ABOUT TEMPORARY SHORING, MEASUREMENT AND PAYMENT.
- PROVIDE PORTABLE CONCRETE BARRIER TO PROTECT TEMPORARY SHORING IF SHORING IS LOCATED WITHIN THE CLEAR ZONE AS DEFINED IN THE AASHTO ROADSIDE DESIGN GUIDE.
- BASED ON THE CLEAR DISTANCE, OFFSET, DESIGN SPEED AND PAVEMENT TYPE, CHOOSE AN UNANCHORED PCB, ANCHORED PCB OR AN OREGON BARRIER FROM THE TABLE SHOWN IN FIGURE B. FOR TRAFFIC LANES AND PORTABLE CONCRETE BARRIER LOCATED ABOVE AND BEHIND TEMPORARY SHORING, THE FOLLOWING ARE DEFINED AS:

CLEAR DISTANCE - HORIZONTAL DISTANCE FROM THE BACK FACE OF THE BARRIER TO THE EDGE OF PAVEMENT FOR TEMPORARY MSE WALL OR TO THE FACE OF NON-ANCHORED TEMPORARY SHORING AS SHOWN IN FIGURE A.

OFFSET - HORIZONTAL DISTANCE FROM THE FRONT FACE OF THE BARRIER TO CENTERLINE OF THE FURTHEST TRAFFIC LANE AS SHOWN IN FIGURE B FOR 3 TRAFFIC LANES.
- AT THE CONTRACTOR'S OPTION OR IF THE MINIMUM REQUIRED CLEAR DISTANCE IS NOT AVAILABLE, SET AN UNANCHORED PCB AGAINST THE TRAFFIC SIDE OF THE SHORING AND DESIGN SHORING FOR TRAFFIC IMPACT OR USE THE "SURCHARGE CASE WITH TRAFFIC IMPACT" FOR THE STANDARD TEMPORARY SHORING.
- USE NCDOT PORTABLE CONCRETE BARRIER (PCB) IN ACCORDANCE WITH ROADWAY STANDARD DRAWING NO. 1170.01 AND SECTION 1170 OF THE STANDARD SPECIFICATIONS.
- USE OREGON TALL F-SHAPE CONCRETE BARRIER IN ACCORDANCE WITH DETAIL DRAWING AND SPECIAL PROVISION OBTAINED FROM: [HTTP://WWW.NCDOT.ORG/DOH/PRECONSTRUCT/WZTC/DESRES/ENGLISH/DESRESENG.HTML](http://www.ncdot.org/DOH/PRECONSTRUCT/WZTC/DESRES/ENGLISH/DESRESENG.HTML)
- UNLESS NOTED OTHERWISE ON THE PLANS, SET PORTABLE CONCRETE BARRIER WITH A MINIMUM DISTANCE OF 2 FT BETWEEN THE FRONT FACE OF THE BARRIER AND THE EDGE OF THE NEAREST TRAFFIC LANE AS SHOWN IN FIGURE A.
- FOR PORTABLE CONCRETE BARRIER ABOVE AND BEHIND TEMPORARY MSE WALLS, PROVIDE A MINIMUM DISTANCE OF 3 FT BETWEEN THE EDGE OF PAVEMENT AND THE WALL FACE AS SHOWN IN FIGURE A. IF THESE MINIMUM REQUIRED DISTANCES ARE NOT AVAILABLE, CONTACT THE ENGINEER.
- TABLE SHOWN IN FIGURE B IS BASED ON NCDOT RESEARCH PROJECT NO. 2005-010 WITH VEHICLE TYPE USED FOR NCHRP 350 CRASH TESTS. BARRIER DEFLECTIONS AND RESULTING MINIMUM REQUIRED CLEAR DISTANCES MIGHT VARY SIGNIFICANTLY FOR LARGER HEAVIER VEHICLES, RUNS OF BARRIER LESS THAN 200' IN LENGTH AND WET OR DRY PAVEMENT.

MINIMUM REQUIRED CLEAR DISTANCE, inches

Barrier Type	Pavement Type	Offset * ft	Design Speed, mph					
			<30	31-40	41-50	51-60	61-70	71-80
Unanchored PCB	Asphalt	<8	24	26	29	32	36	40
		8-14	26	28	31	35	38	42
		14-20	27	29	34	36	39	43
		20-26	28	31	35	38	40	44
		26-32	29	32	36	39	42	45
		32-38	30	34	38	41	43	46
		38-44	31	34	41	43	45	48
		44-50	31	35	41	43	46	49
		50-56	32	36	42	44	47	50
	>56	32	36	42	45	47	51	
	Concrete	<8	17	18	21	22	25	26
		8-14	19	20	23	25	26	29
		14-20	22	22	24	26	28	31
		20-26	23	24	26	27	30	34
		26-32	24	25	27	28	32	35
		32-38	24	26	27	30	33	36
		38-44	25	26	28	30	34	37
		44-50	26	26	28	32	35	37
50-56		26	26	28	32	35	38	
>56	26	27	29	32	36	38		
Anchored PCB or Oregon Barrier	Asphalt	All Offsets	24 for All Design Speeds					
Anchored PCB or Oregon Barrier	Concrete (including bridge approach slabs)	All Offsets	12 for All Design Speeds					

* See Figure Below

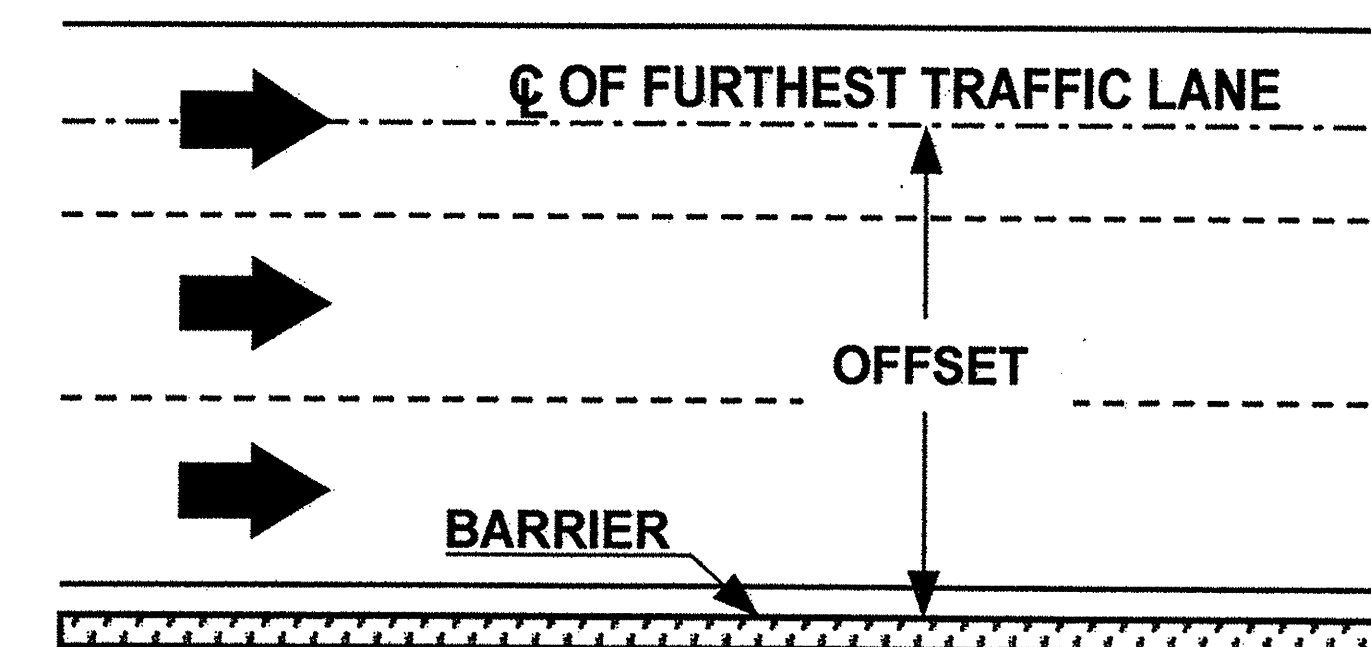
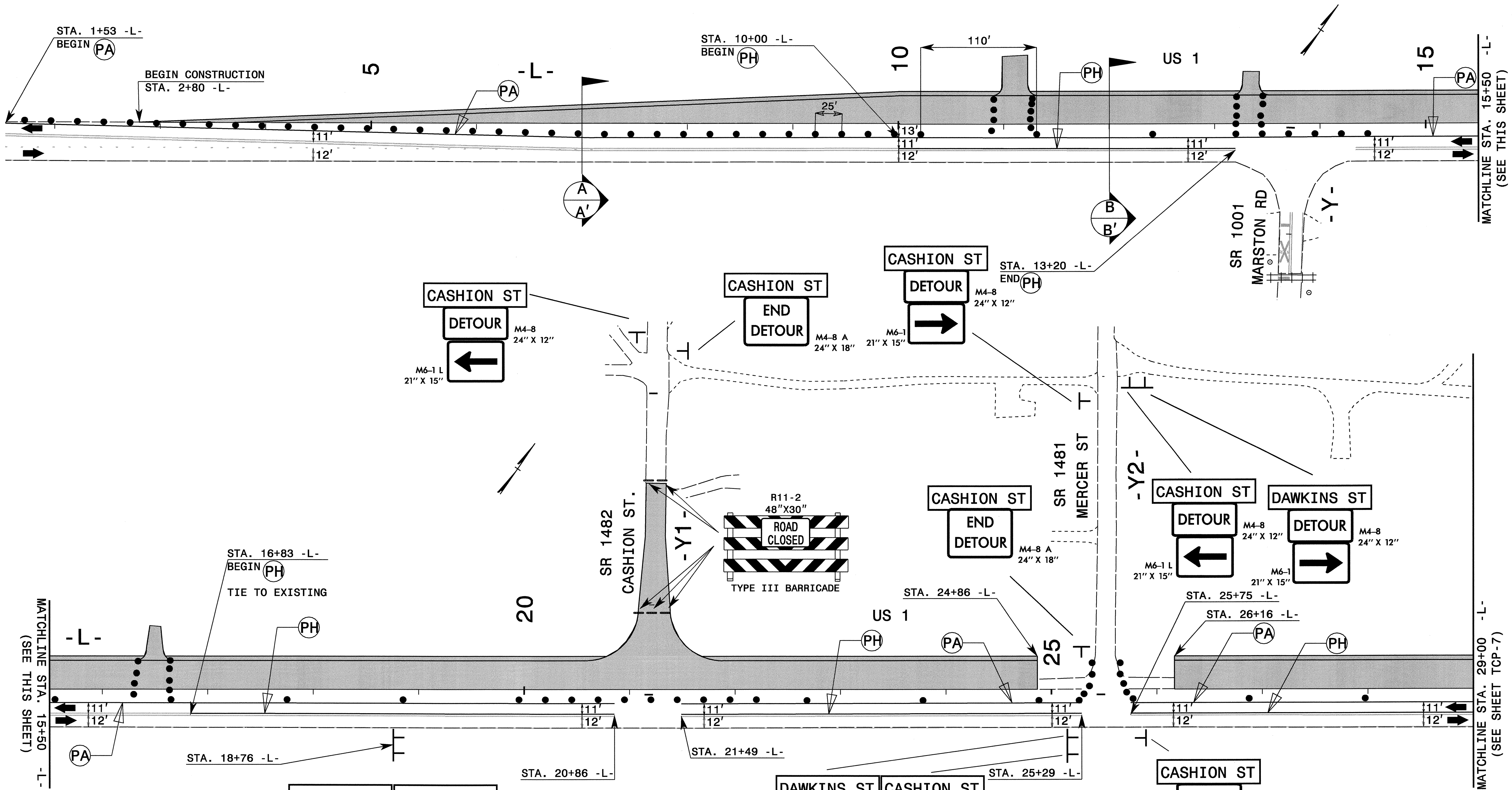

FIGURE B

APPROVED: _____	DATE: _____	PORTABLE CONCRETE BARRIER AT TEMPORARY SHORING LOCATIONS	
	SCALE: NONE		REVISIONS
	DATE: 3/07		
	DESIGN BY: JI		
	REVIEWED BY: JI		

22-MAR-2007 10:14
 C:\DOT\DESIGN\GROUPS\WZTC\share\share\stds\in-progress\barrierstd.dgn
 WZTC2229i
 AT
 IMPORT 611



- : PROPOSED PAVEMENT MARKING LINE
- - - : EXISTING PAVEMENT MARKING LINE
- ↪ : QA ↗ : QD ↻ : QG
- ↪ : QB ↗ : QE
- ↪ : QC ↗ : QF
- ↪ : EXISTING PAVEMENT MARKING SYMBOL

FOR SECTIONAL VIEWS A-A' AND B-B' SEE SHEET TCP-6

- FOR PAVEMENT MARKING SCHEDULE SEE SHEET TCP-4
- TEMPORARY RAISED PAVEMENT MARKERS SHALL BE PLACED IN ACCORDANCE WITH RSD 1250.05 AND 1251.01

APPROVED:	DATE: 2/19/08	PHASE I DETAIL	
SEAL			
SCALE: NONE	DATE: 02/08		REVISIONS
DWG. BY: DAH	DESIGN BY: DAH		
REVIEWED BY: JWW			

19-FEB-2008 09:58
 \\dot\dfs\root\Projects\R2502A\TrafficControl\Phase I\NR-2502A_Tc_TCP-PHI_05.dgn
 ahayes AT WZTC22424

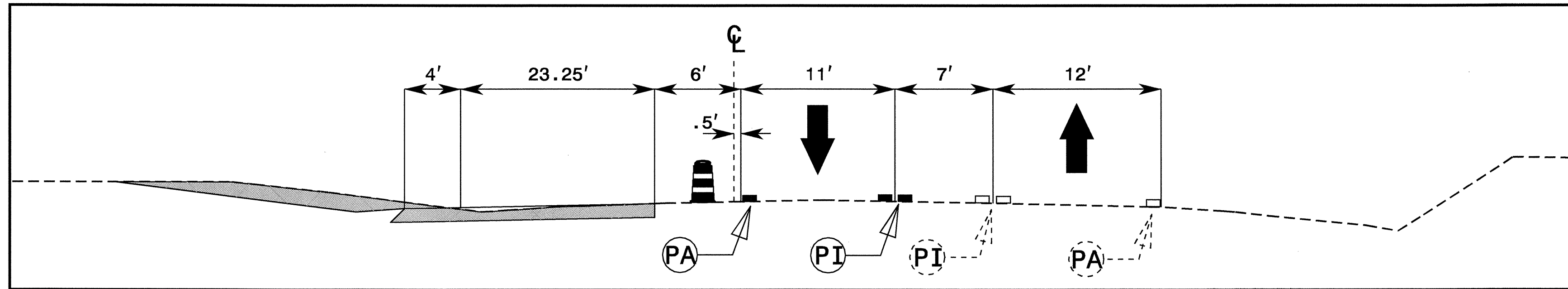

CUT SECTION A
STA. 7+00 -L- A/A'

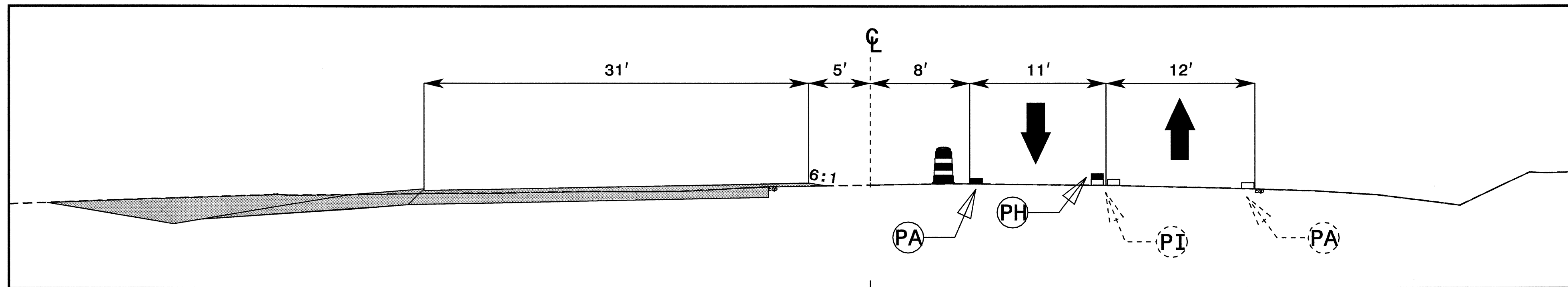

CUT SECTION B
STA. 12+00 -L- B/B'

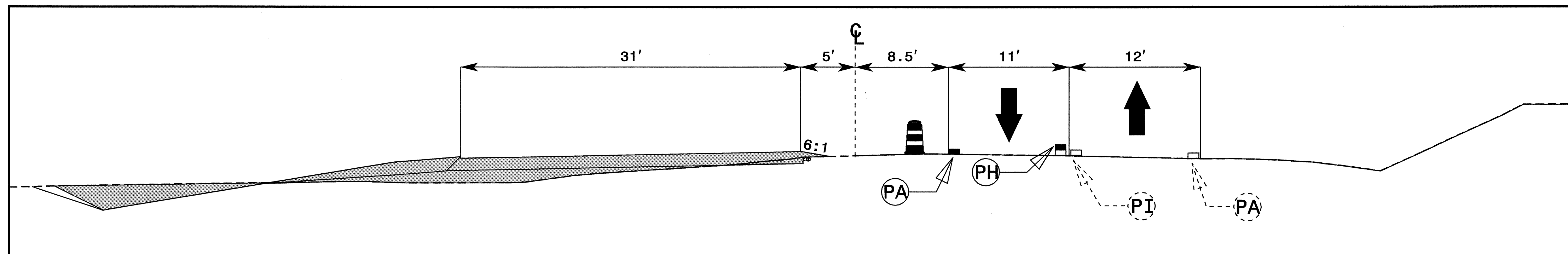

CUT SECTION C
STA. 31+50 -L- C/C'

19-FEB-2008 09:57
 \\dot\dfsroot\Pro\TIP\Projects-R\2502A\TrafficControl\Top\Phase I\NR-2502A_TC_TCP_PHL06_CS-A-C.dgn
 ghayes AT WZTC224241

APPROVED: _____	DATE: _____	PHASE I DETAIL	
SCALE: NONE	DATE: 02/08		REVISIONS
DWG. BY: DAH	DESIGN BY: DAH		
REVIEWED BY: JWW			

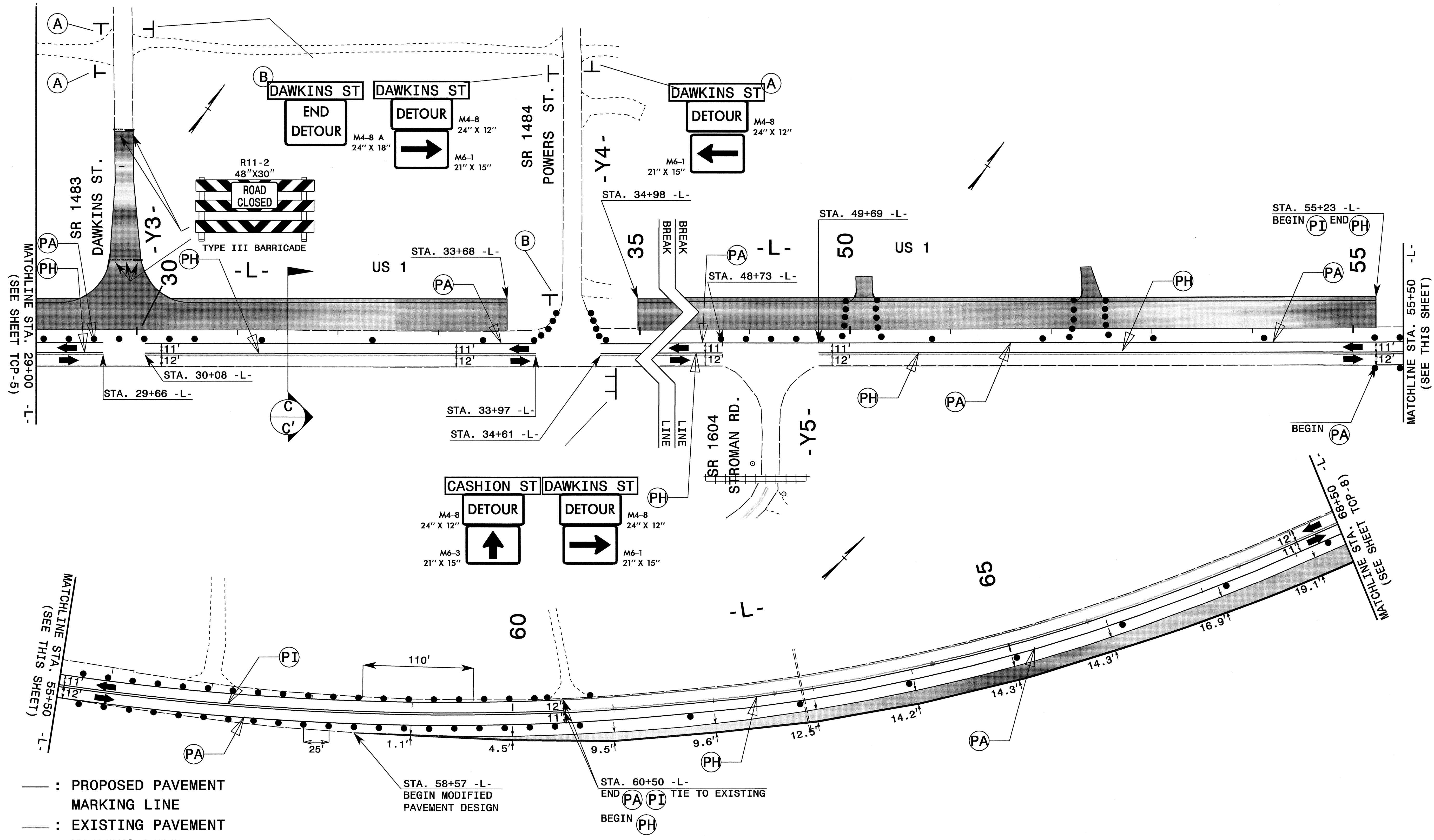

- : PROPOSED PAVEMENT MARKING LINE
- : EXISTING PAVEMENT MARKING LINE
- ↪ : QA ↪ : QD ↪ : QG
- ↪ : QB ↪ : QE
- ↪ : QC ↪ : QF
- ↪ : EXISTING PAVEMENT MARKING SYMBOL

- FOR PAVEMENT MARKING SCHEDULE SEE SHEET TCP-4
- TEMPORARY RAISED PAVEMENT MARKERS SHALL BE PLACED IN ACCORDANCE WITH RSD 1250.05 AND 1251.01

APPROVED: _____ DATE: _____	PHASE I DETAIL									
	SCALE: NONE									
	DATE: 02/08									
	DESIGN BY: DAH									
	REVIEWED BY: JWW									
		<table border="1"> <thead> <tr> <th colspan="2">REVISIONS</th> </tr> </thead> <tbody> <tr> <td> </td> <td> </td> </tr> <tr> <td> </td> <td> </td> </tr> <tr> <td> </td> <td> </td> </tr> </tbody> </table>	REVISIONS							
REVISIONS										

19-FEB-2008 09:57 \\dot\dfsroot\proj\ip\projects-r\2502A\TrafficControl\TopVPhase I\NR-2502A-Tc_TCP_PHL-07.dgn
 AT WZTC224241

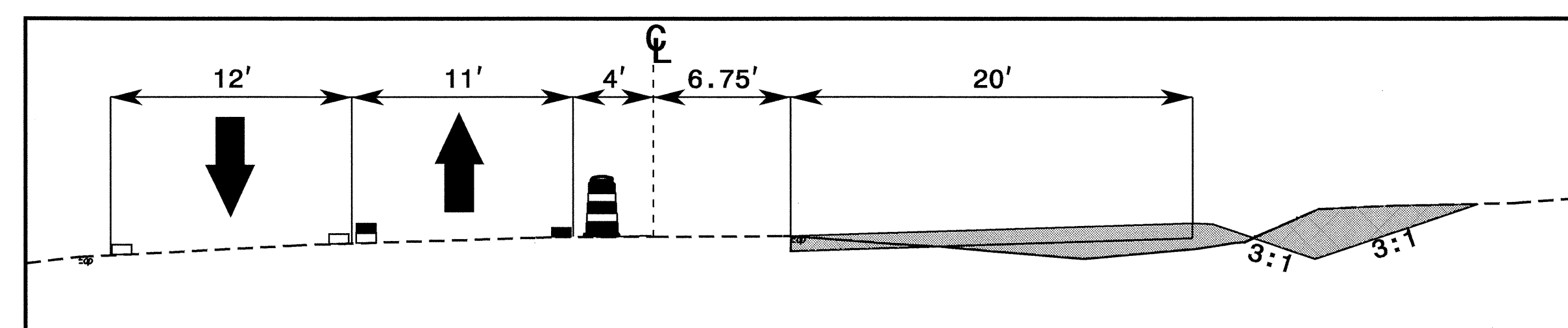
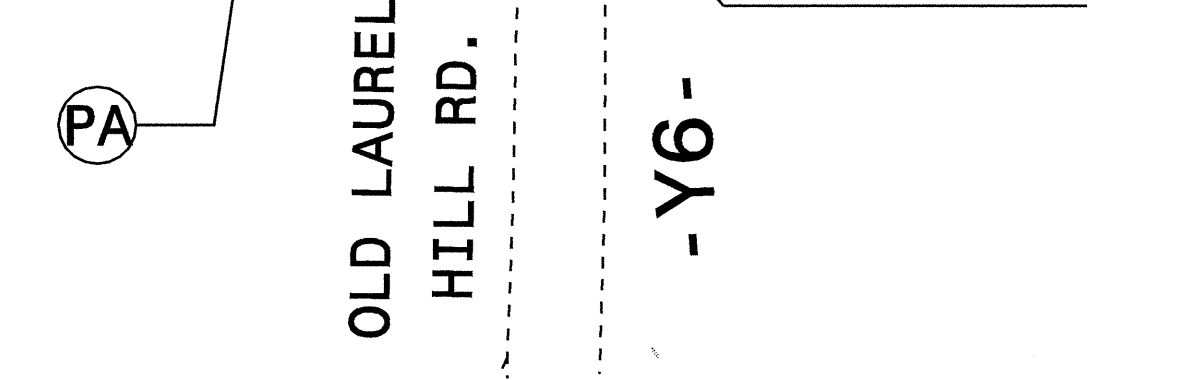
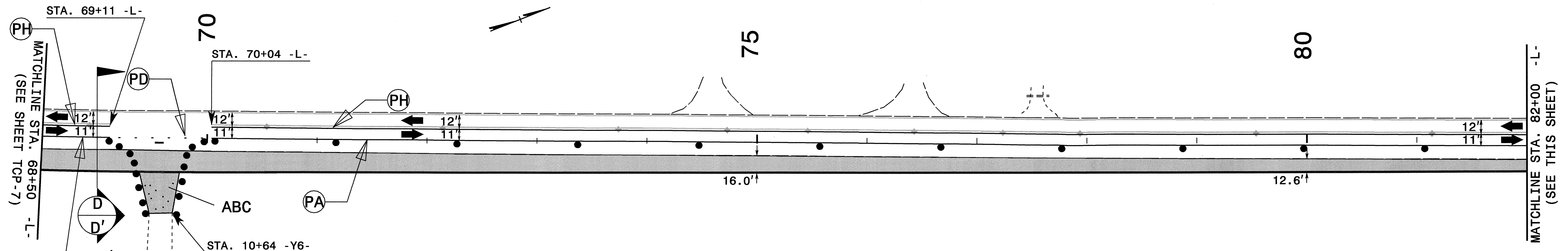

CUT SECTION D
STA. 69+00 -L- D D'

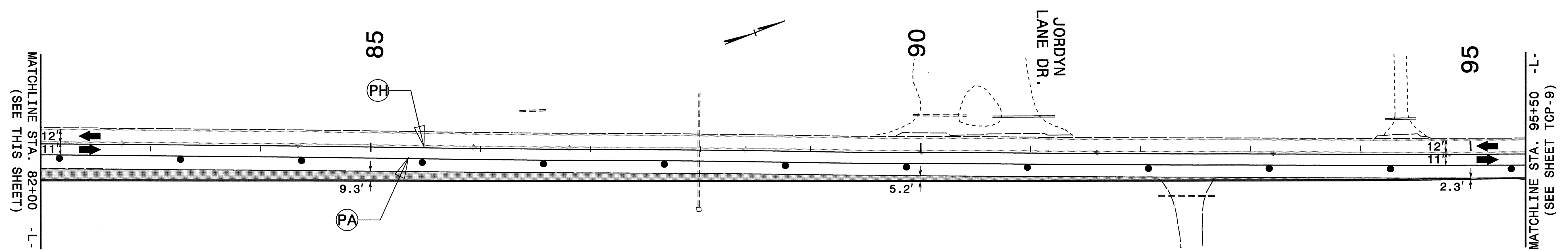

- : PROPOSED PAVEMENT MARKING LINE
- : EXISTING PAVEMENT MARKING LINE
- ↪ : QA ↻ : QD ↻ : QG
- ↪ : QB ↻ : QE
- ↪ : QC ↻ : QF
- ↪ : EXISTING PAVEMENT MARKING SYMBOL

- FOR PAVEMENT MARKING SCHEDULE SEE SHEET TCP-4
- TEMPORARY RAISED PAVEMENT MARKERS SHALL BE PLACED IN ACCORDANCE WITH RSD 1250.05 AND 1251.01

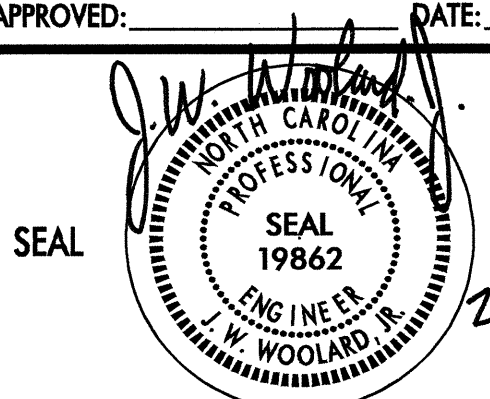
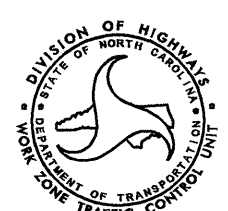
APPROVED: 	DATE: 2/19/08	PHASE I DETAIL	
SEAL			
SCALE: NONE	DATE: 02/08		REVISIONS
DWG. BY: DAH	DESIGN BY: DAH		
REVIEWED BY: JWW			

I9-FEB-2008 09:56
 \\dot\dfs\root\Pro\TIP\Projects-R\2502A\Traffic\TrafficControl\Tcp\Phase I\NR-2502A_TC-TCP_PHL_08.dgn
 ahays AT WZTC224241

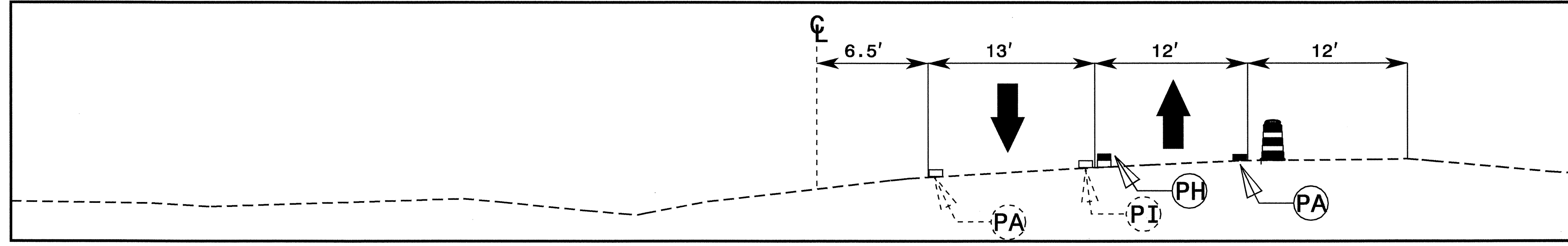
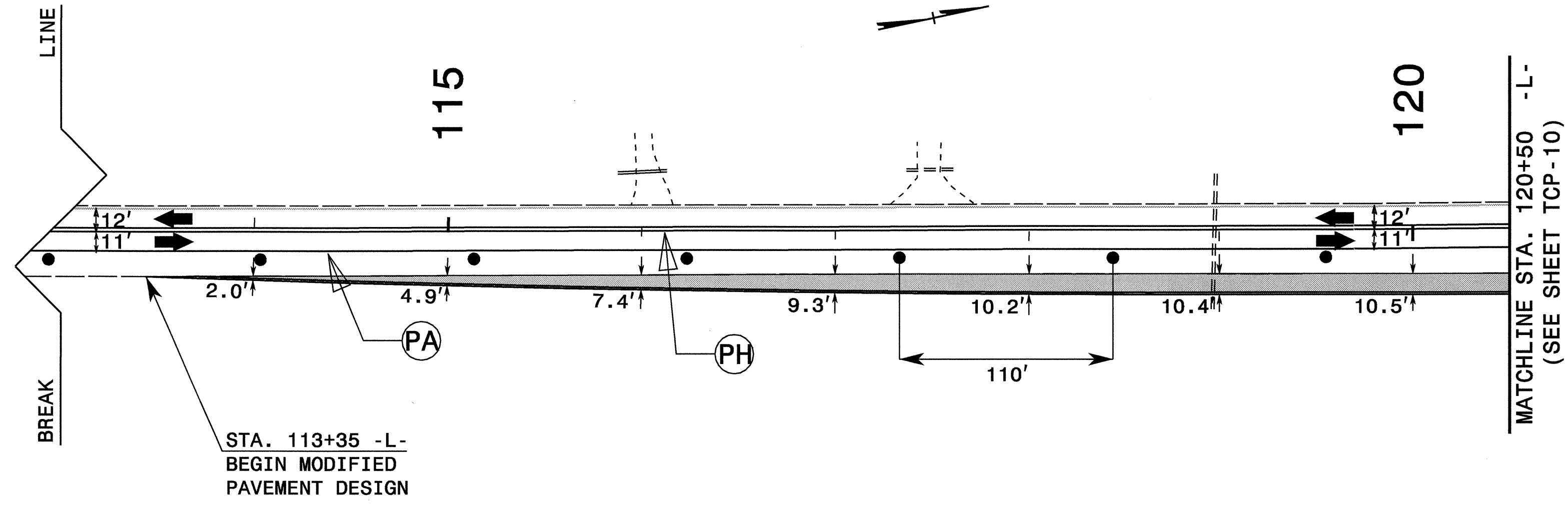
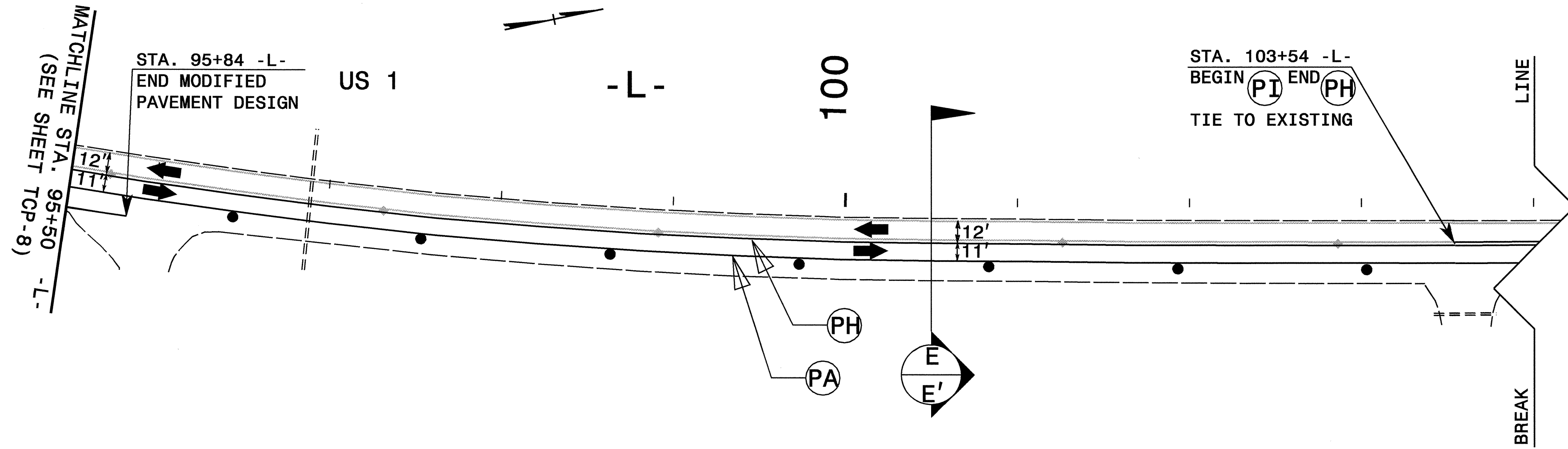

- : PROPOSED PAVEMENT MARKING LINE
- - - : EXISTING PAVEMENT MARKING LINE
- ↪ : QA ↻ : QD ↻ : QG
- ↪ : QB ↻ : QE
- ↪ : QC ↻ : QF
- ↪ : EXISTING PAVEMENT MARKING SYMBOL

- FOR PAVEMENT MARKING SCHEDULE SEE SHEET TCP-4
- TEMPORARY RAISED PAVEMENT MARKERS SHALL BE PLACED IN ACCORDANCE WITH RSD 1250.05 AND 1251.01

APPROVED: _____ DATE: _____

SEAL

2/19/08

PHASE I DETAIL

SCALE: NONE		REVISIONS
DATE: 02/08		
DESIGN BY: DAH		
REVIEWED BY: JWW		

I9-FEB-2008 09:55 \\dot\dfs\root\Pro\IP\Projects-R\2502A\TrafficControl\Top\Phase I\NR-2502A-TC-TCP_PHL_09.dgn
 ahays AT WZTC22424

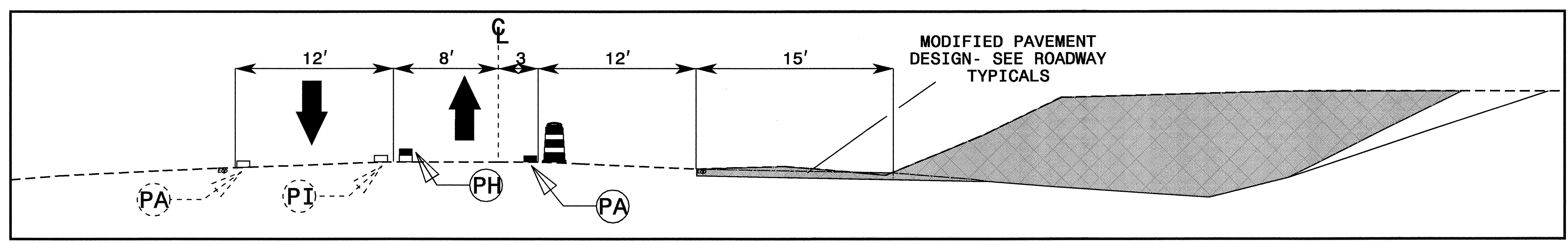
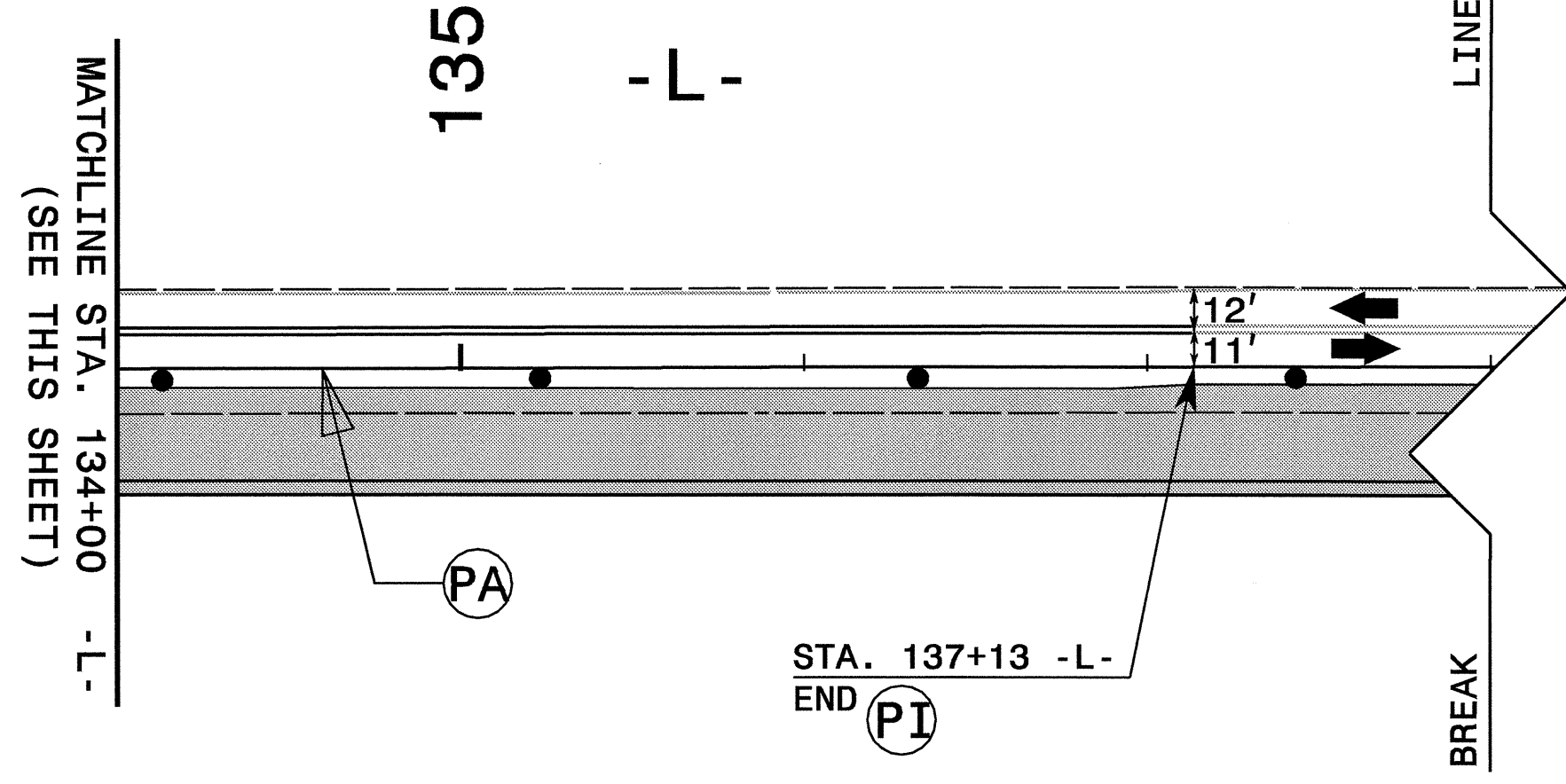
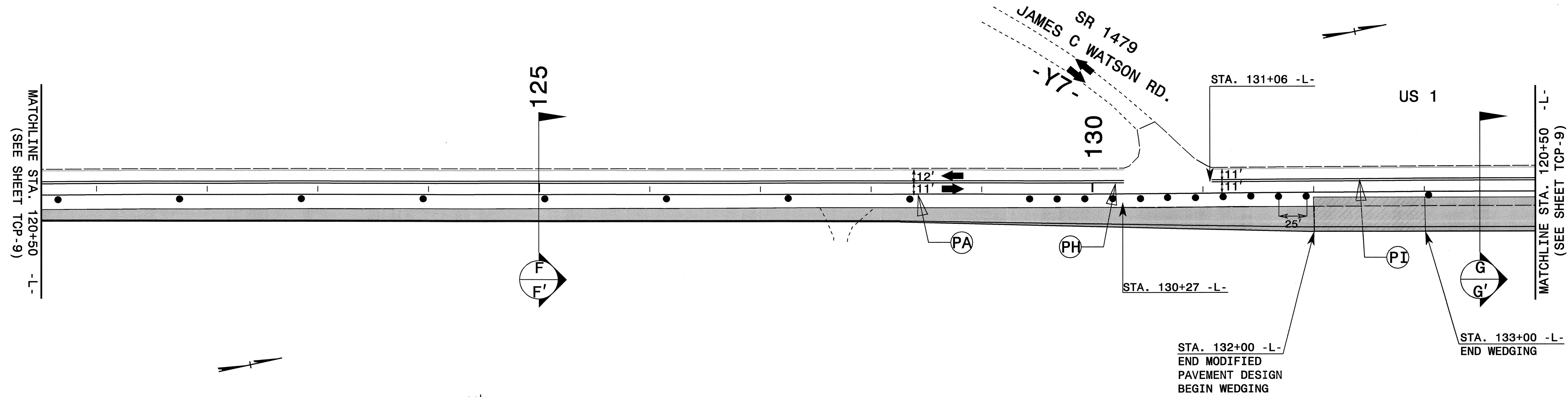

CUT SECTION F-F'
STA. 125+00 -L-

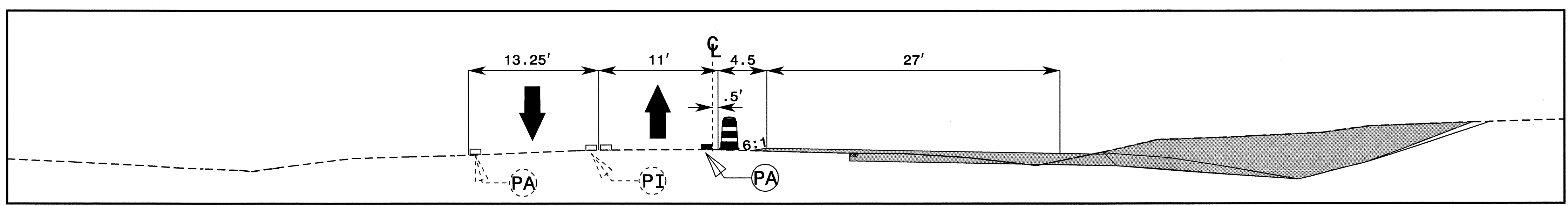

CUT SECTION G-G'
STA. 133+50 -L-

- : PROPOSED PAVEMENT MARKING LINE
- - - : EXISTING PAVEMENT MARKING LINE
- ↪ : QA ↪ : QD ↪ : QG
- ↪ : QB ↪ : QE
- ↪ : QC ↪ : QF
- ↪ : EXISTING PAVEMENT MARKING SYMBOL

- FOR PAVEMENT MARKING SCHEDULE SEE SHEET TCP-4
- TEMPORARY RAISED PAVEMENT MARKERS SHALL BE PLACED IN ACCORDANCE WITH RSD 1250.05 AND 1251.01

APPROVED:	DATE: 2/19/08	PHASE I DETAIL	
SEAL			
SCALE: NONE			
DATE: 02/08			
DWG. BY: DAH			
DESIGN BY: DAH			
REVIEWED BY: JWW		REVISIONS	

19-FEB-2008 09:51
 \\dot\dfsroot\Pro\IP\Projects-R\2502A\TrafficControl\Top\Phase I\NR-2502A_TC_TCP_P1_10.dgn
 at WZTC22424

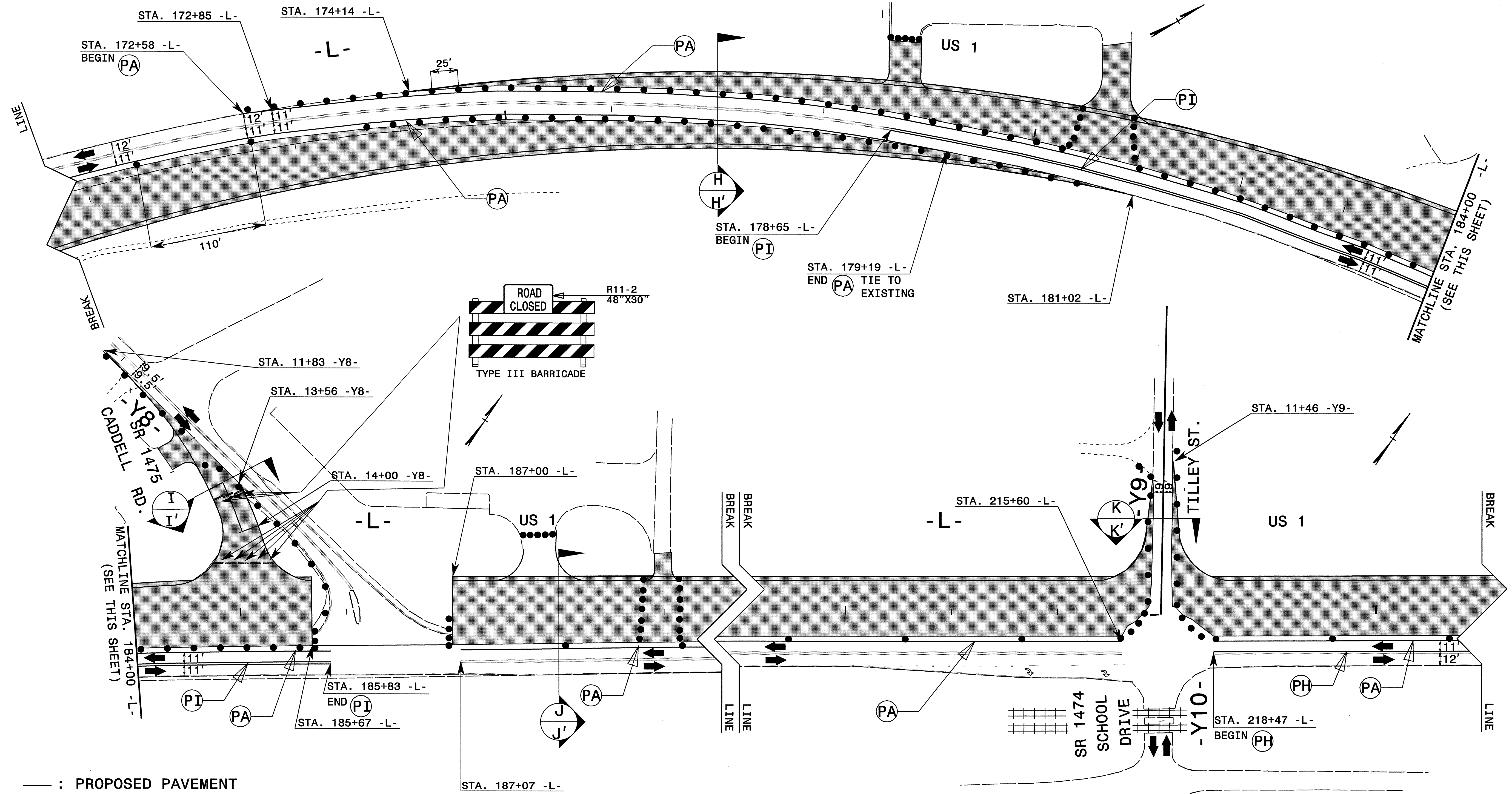

- : PROPOSED PAVEMENT MARKING LINE
- : EXISTING PAVEMENT MARKING LINE
- ↪ : QA ↪ : QD ↪ : QG
- ↪ : QB ↪ : QE
- ↪ : QC ↪ : QF
- ↪ : EXISTING PAVEMENT MARKING SYMBOL

- FOR SECTIONAL VIEWS H-H', I-I', J-J', AND K-K' SEE SHEET TCP-12
- FOR PAVEMENT MARKING SCHEDULE SEE SHEET TCP-4
- TEMPORARY RAISED PAVEMENT MARKERS SHALL BE PLACED IN ACCORDANCE WITH RSD 1250.05 AND 1251.01

APPROVED: _____ DATE: _____

SEAL

PHASE I DETAIL

SCALE: NONE		<table border="1"> <tr><th colspan="2">REVISIONS</th></tr> <tr><td> </td><td> </td></tr> <tr><td> </td><td> </td></tr> <tr><td> </td><td> </td></tr> </table>	REVISIONS							
REVISIONS										
DATE: 02/08										
DWG. BY: DAH										
DESIGN BY: DAH										
REVIEWED BY: JWW	CADD FILE									

19-FEB-2008 10:54
 \\dot\dfsroot\proj\ip\proj\projects-r\2502a\TrafficControl\Top\Phase I\R-2502A_TC_TCP_P1.dgn
 chaves AT WZTC22424

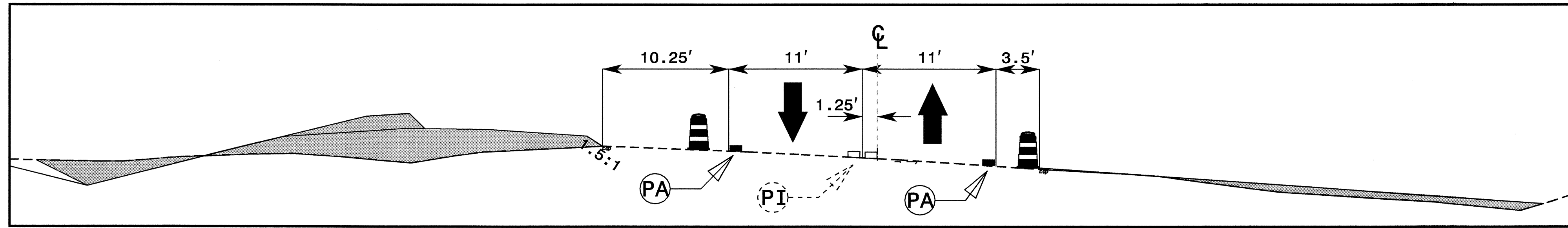

CUT SECTION $\frac{H}{H'}$
STA. 177+00 -L-

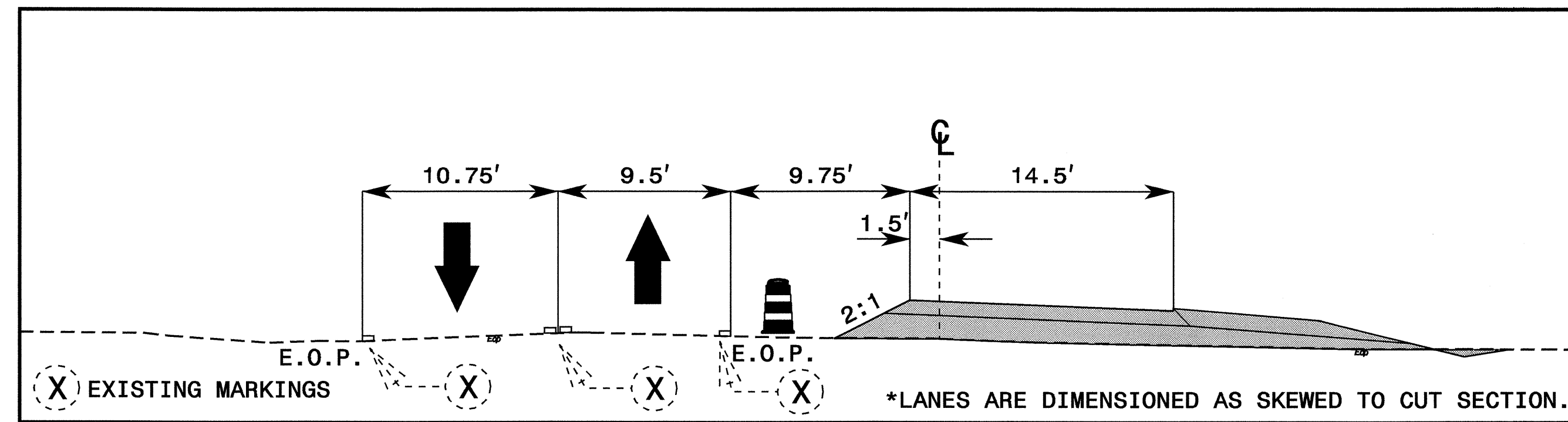

CUT SECTION $\frac{I}{I'}$
STA. 13+50 -Y8-

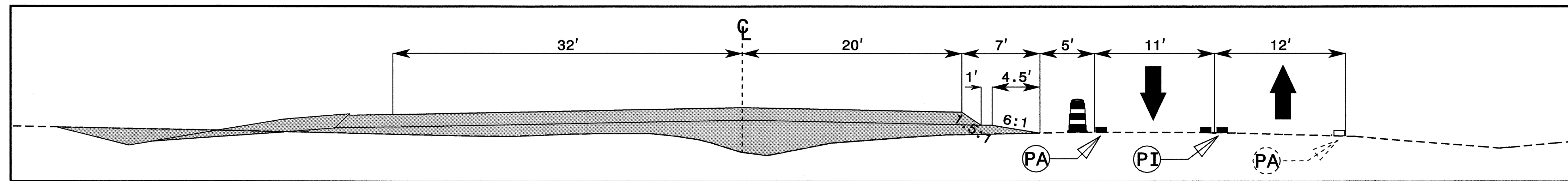

CUT SECTION $\frac{J}{J'}$
STA. 188+00 -L-

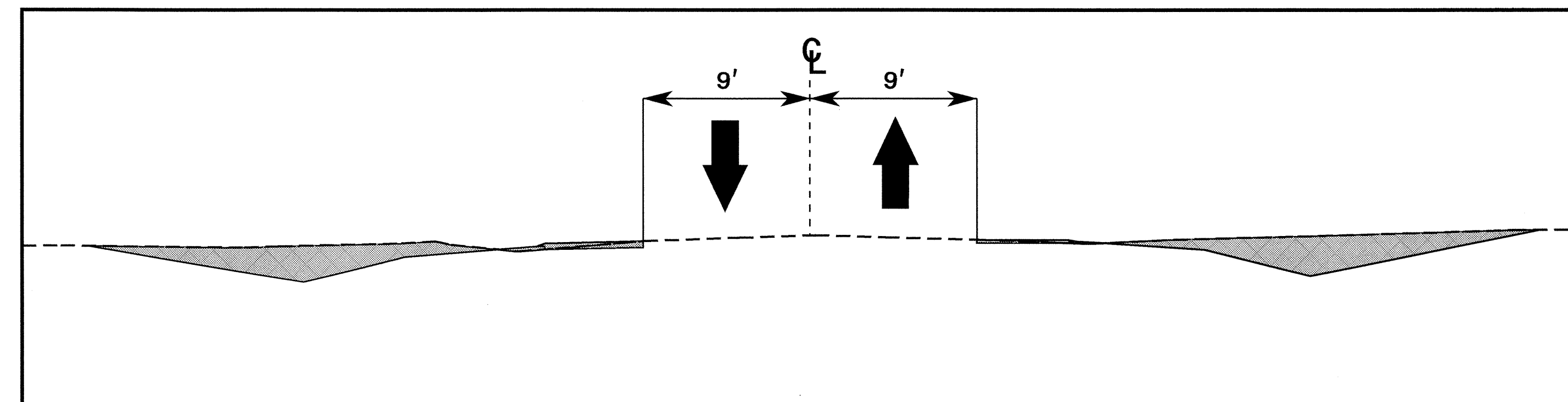

CUT SECTION $\frac{K}{K'}$
STA. 12+00 -Y9-

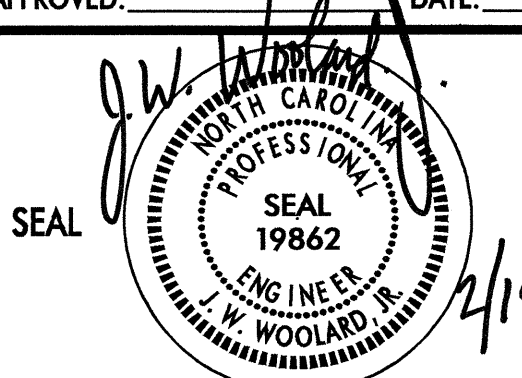
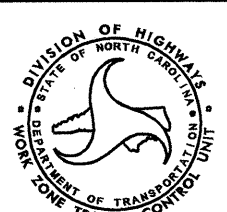

19-FEB-2008 09:47
 \\dot\dfsroot\Pro\TIPPro\Projects-R\2502A\Traffic\TrafficControl\Top\Phase I\NR-2502A_TC-TCP_PHI_I2_CS-I-L.dgn
 ghays AT WZTC224241

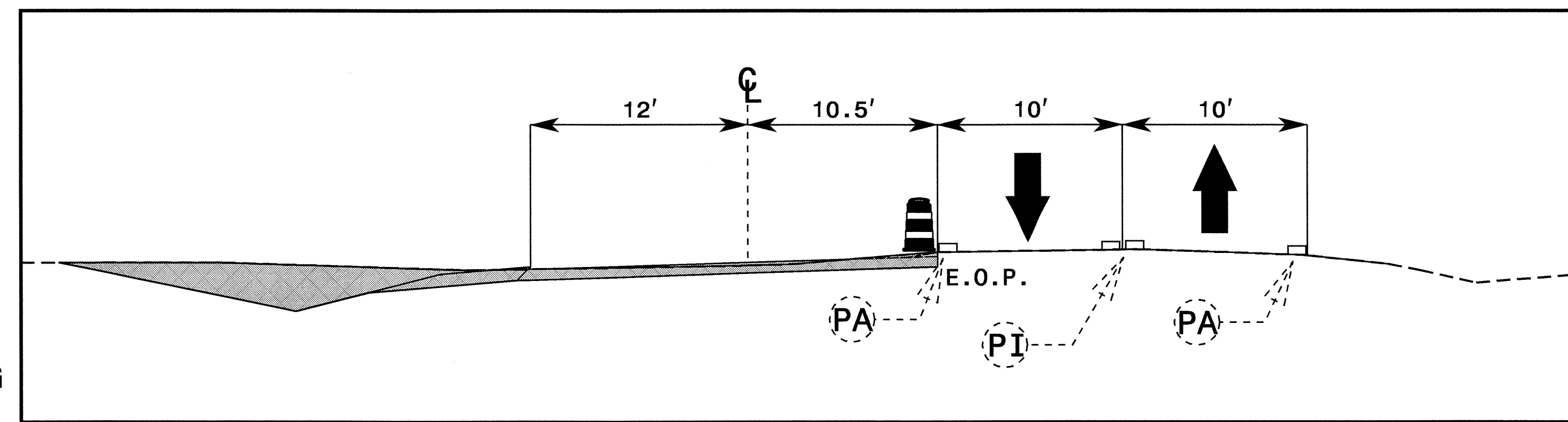
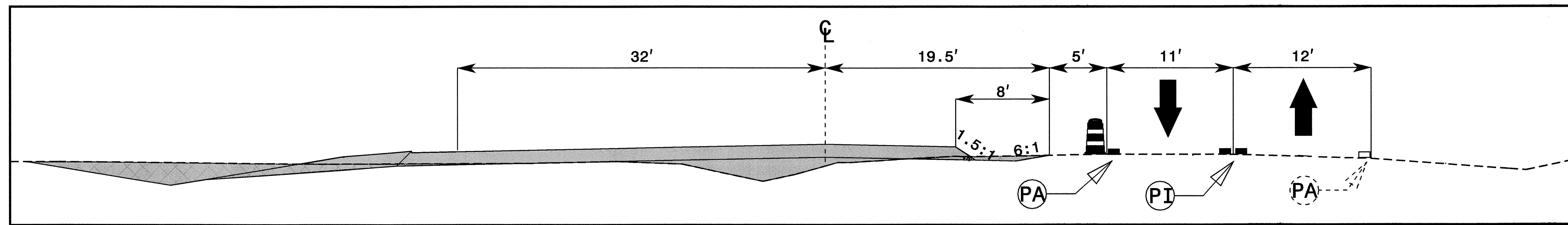
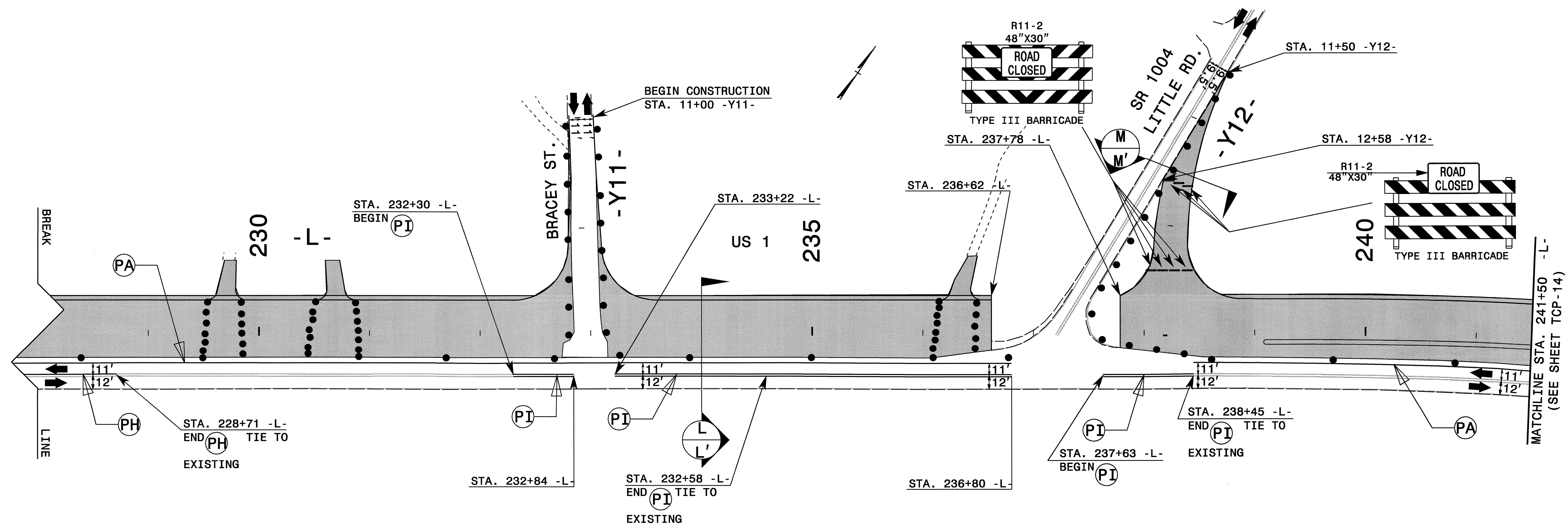
APPROVED: 	DATE: 2/19/08	PHASE I DETAIL 		REVISIONS <table border="1"> <tr><td> </td><td> </td></tr> <tr><td> </td><td> </td></tr> <tr><td> </td><td> </td></tr> <tr><td> </td><td> </td></tr> </table>									
SCALE: NONE	DATE: 02/08	DESIGN BY: DAH	REVIEWED BY: JWW	CADD FILE									

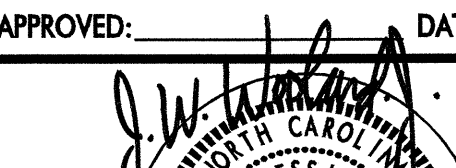
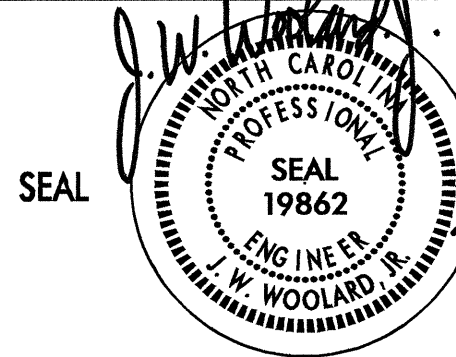

- : PROPOSED PAVEMENT MARKING LINE
- - - : EXISTING PAVEMENT MARKING LINE
- ↖ : QA ↗ : QD ↕ : QG
- ↘ : QB ↙ : QE
- ↑ : QC ↓ : QF
- ↶ : EXISTING PAVEMENT MARKING SYMBOL

- FOR PAVEMENT MARKING SCHEDULE SEE SHEET TCP-4
- TEMPORARY RAISED PAVEMENT MARKERS SHALL BE PLACED IN ACCORDANCE WITH RSD 1250.05 AND 1251.01

APPROVED: 	DATE: 2/19/08	PHASE I DETAIL	
SEAL: 			
SCALE: NONE	DATE: 02/08		REVISIONS
DESIGN BY: DAH	REVIEWED BY: JWW		
DESIGN BY: DAH			

19-FEB-2008 09:47
 \\dot\dfsroot\01\Proj\TipProjects\NR2502A\Traffic\Control\Top\Phase I\NR-2502A_TC_TCP_P1_13.dgn
 chaves AT WZTC224241

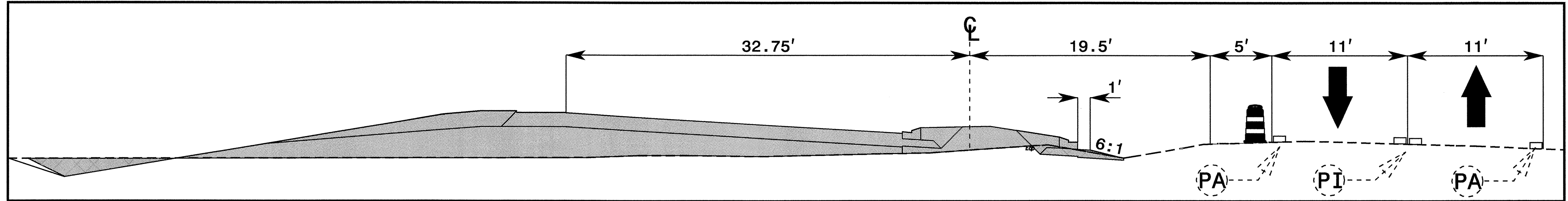

CUT SECTION
STA. 244+00 -L- N

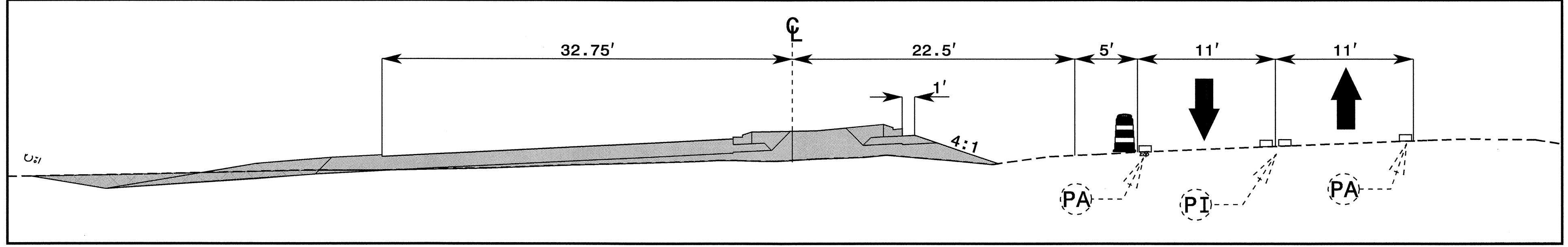

CUT SECTION
STA. 263+00 -L- O

- : PROPOSED PAVEMENT MARKING LINE
- : EXISTING PAVEMENT MARKING LINE
- ↪ : QA ↪ : QD ↪ : QG
- ↪ : QB ↪ : QE
- ↪ : QC ↪ : QF
- ↪ : EXISTING PAVEMENT MARKING SYMBOL

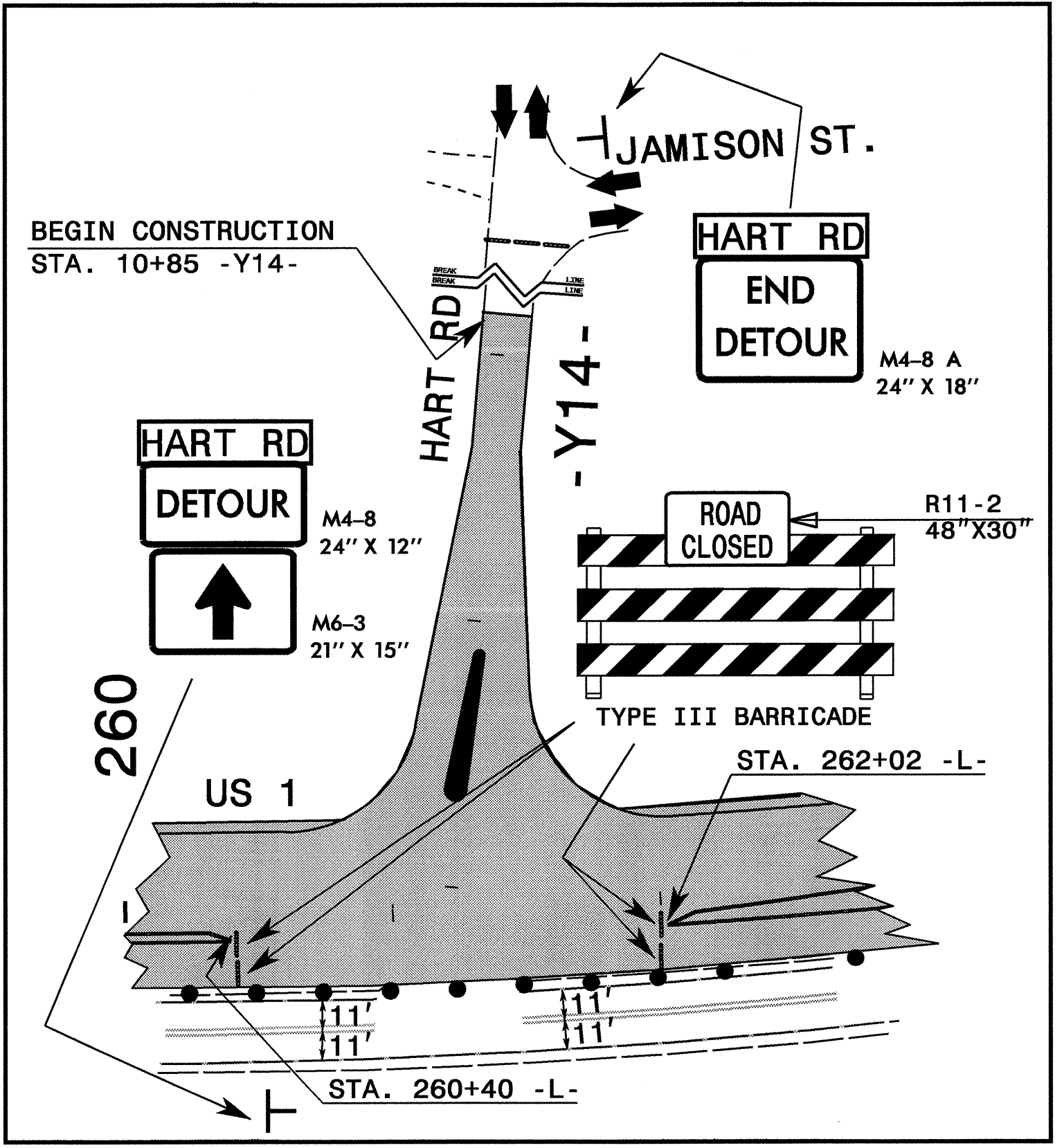

INSET 'A'

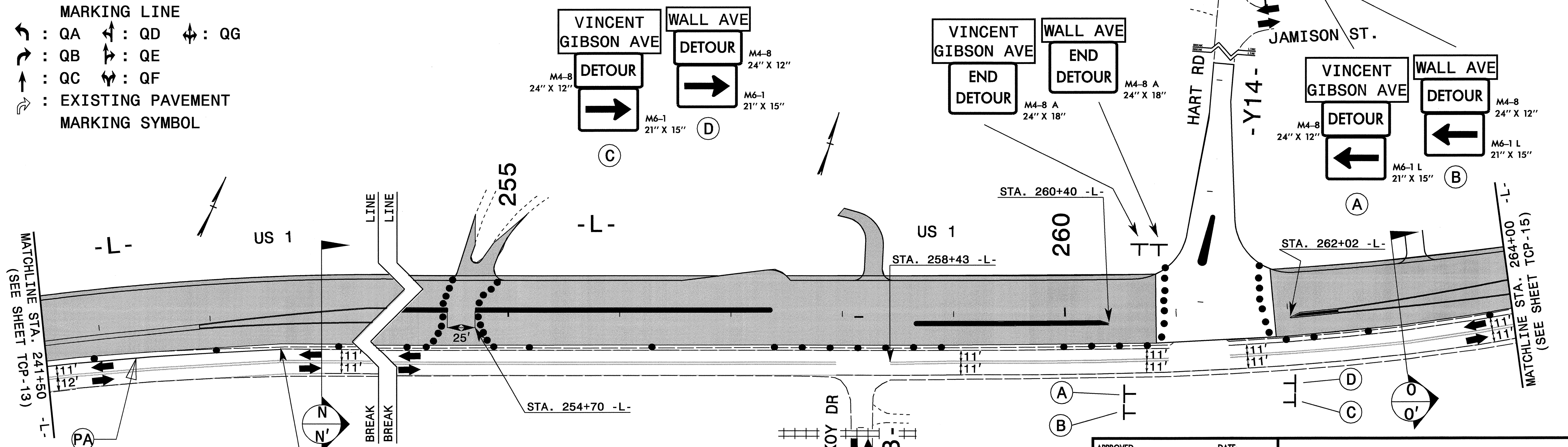

MATCHLINE STA. 241+50 -L- (SEE SHEET TCP-13)

MATCHLINE STA. 264+00 -L- (SEE SHEET TCP-15)

STA. 243+62 -L- END TIE TO EXISTING

- FOR PAVEMENT MARKING SCHEDULE SEE SHEET TCP-4
- TEMPORARY RAISED PAVEMENT MARKERS SHALL BE PLACED IN ACCORDANCE WITH RSD 1250.05 AND 1251.01

APPROVED: _____ DATE: _____

SEAL

2/19/08

PHASE I DETAIL

SCALE: NONE		REVISIONS
DATE: 02/08		
DWG. BY: DAH		
DESIGN BY: DAH		
REVIEWED BY: JWW		

19-FEB-2008 09:46
 \\dot\gfrs\root\proj\proj\proj\R2502A\TrafficControl\TopVPhase [NR-2502A_TC_TCP_Phl_14.dgn
 chaves AT WZTC224241

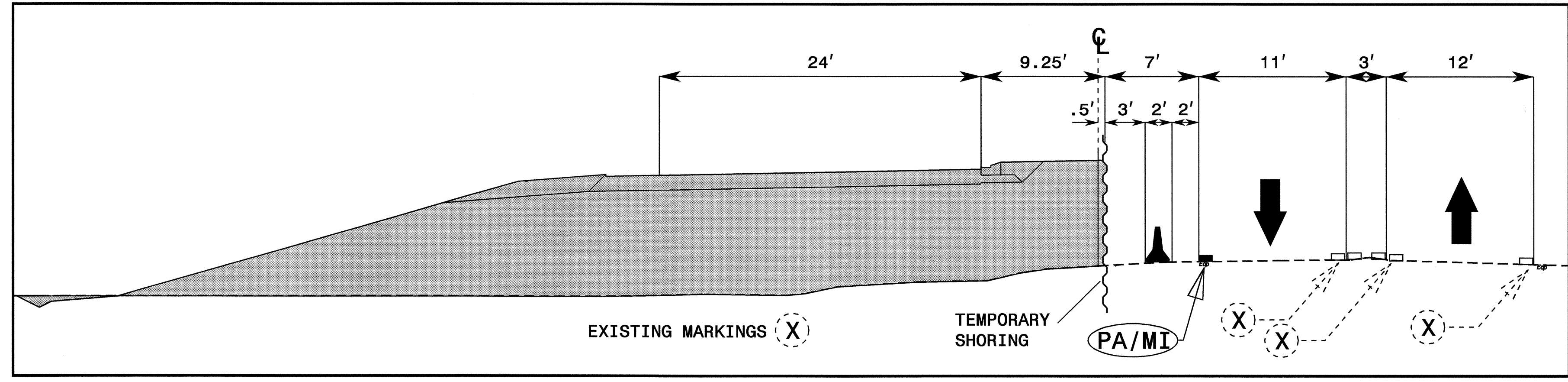

CUT SECTION P
STA. 275+00 -L- P'

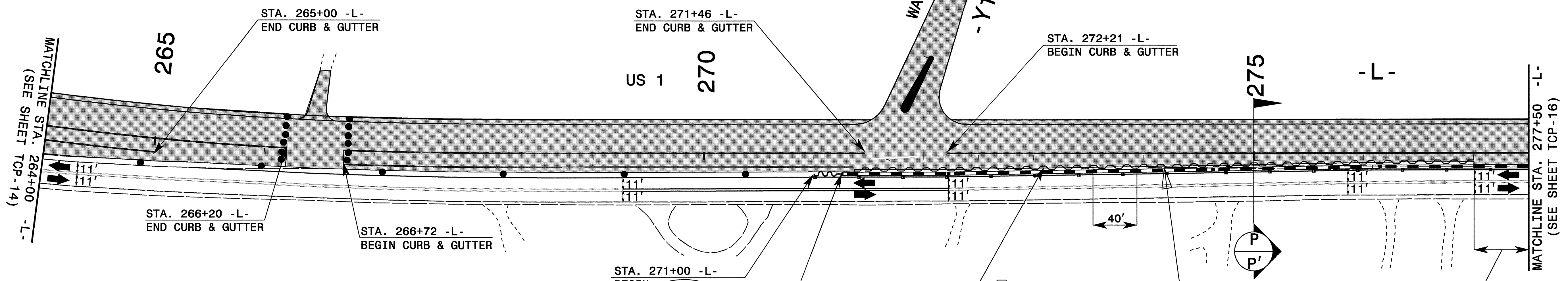
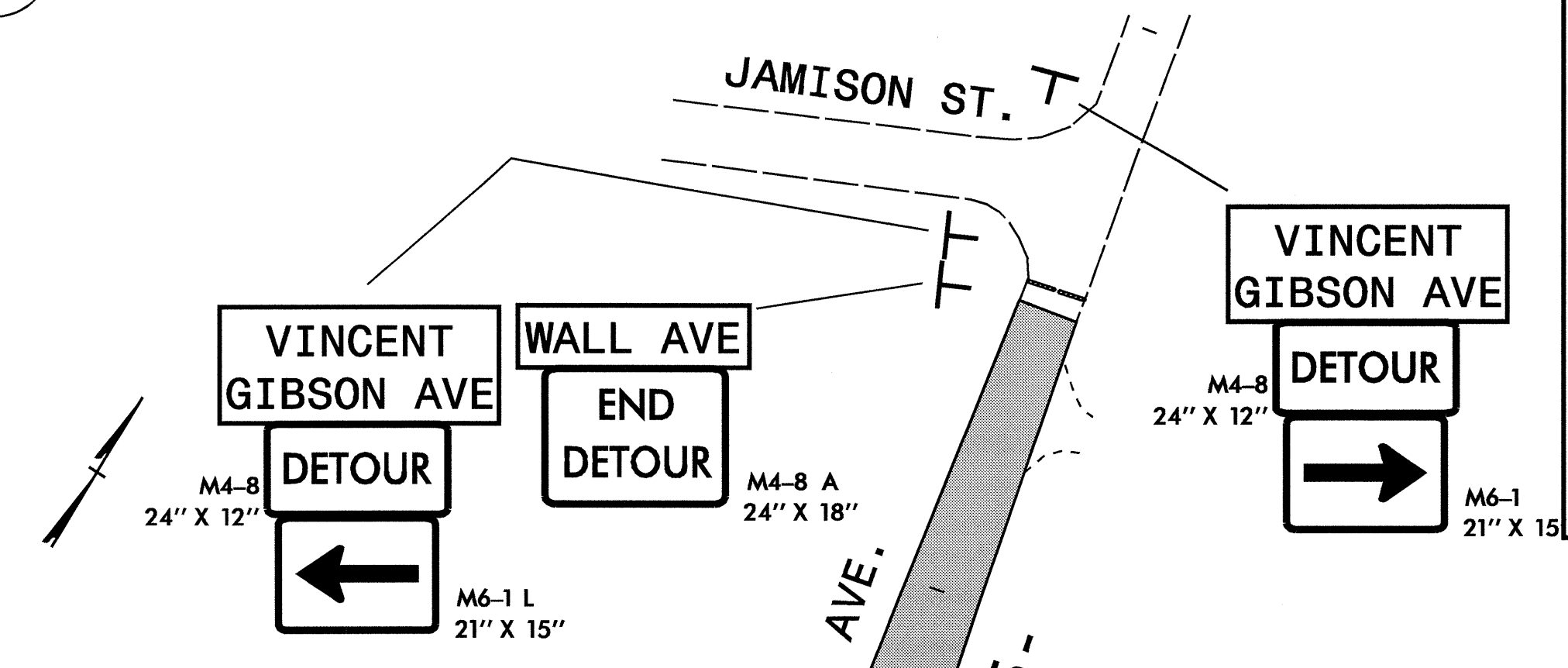
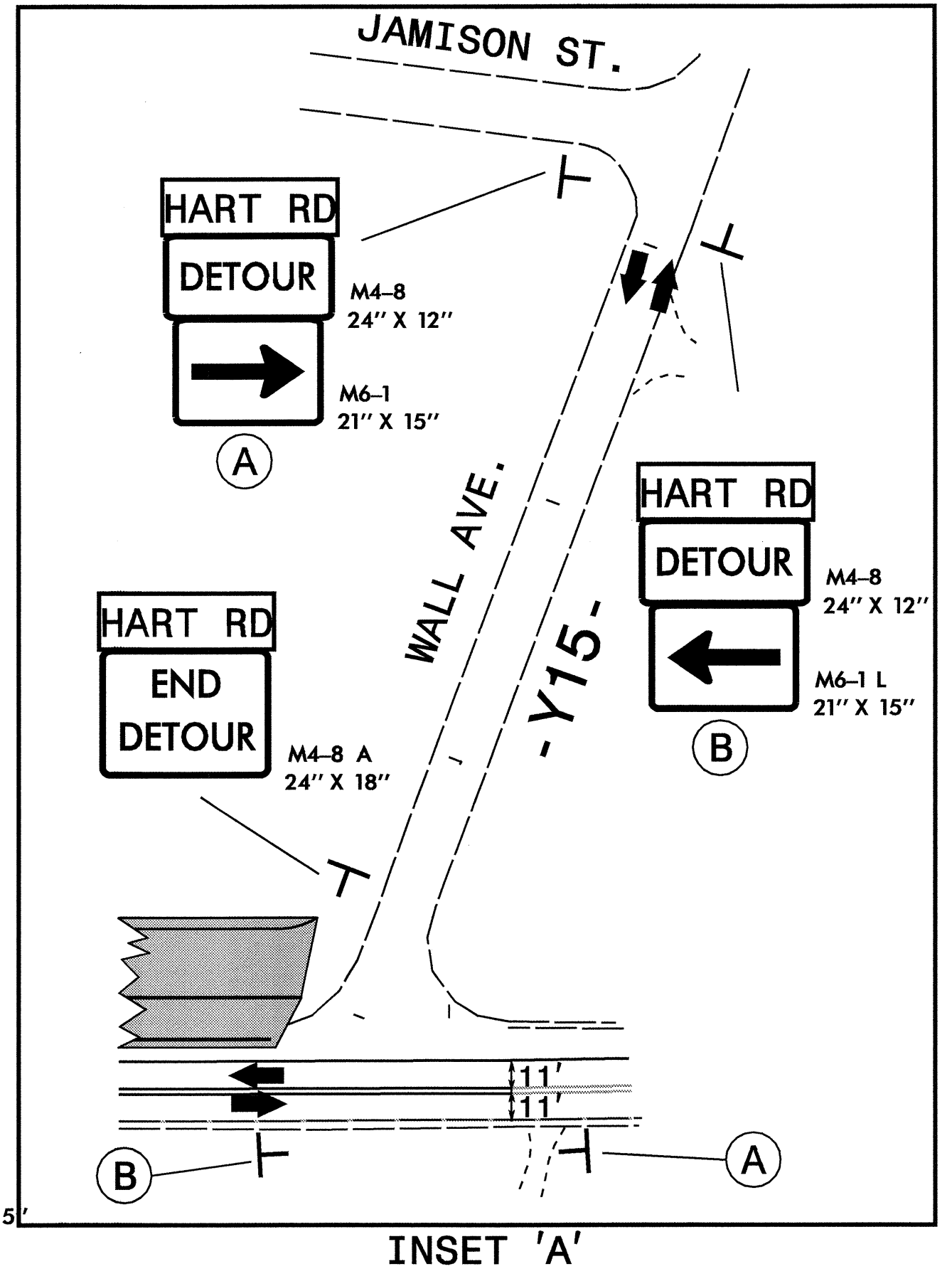

- : PROPOSED PAVEMENT MARKING LINE
- - - : EXISTING PAVEMENT MARKING LINE
- ↪ : QA ↪ : QD ↪ : QG
- ↪ : QB ↪ : QE
- ↪ : QC ↪ : QF
- ↪ : EXISTING PAVEMENT MARKING SYMBOL

① QUANTITY = 4512 SQ FT
TEMPORARY SHORING
FROM STA. 271+36 -L-, 18.5' RT
TO STA. 277+00 -L-, 18.5' RT

STA. 277+00 -L-
TRANSITION FILL HORIZONTALLY
FROM SHORING TO TOP OF CURB
& GUTTER AT A VERTICAL 2:1 SLOPE

- FOR PAVEMENT MARKING SCHEDULE SEE SHEET TCP-4
- TEMPORARY RAISED PAVEMENT MARKERS SHALL BE PLACED IN ACCORDANCE WITH RSD 1250.05 AND 1251.01

APPROVED: *J.W. Woolard* DATE: 2/19/08

SEAL:

PHASE I DETAIL

SCALE: NONE		REVISIONS
DATE: 02/08		
DESIGN BY: DAH		
REVIEWED BY: JWW		

19-FEB-2008 09:46 \\dot\dfsroot\proj\TIP\Projects-R\2502A\TrafficControl\Phase I\Phase I\TrafficControl\Tcp-15.dgn AT WZTC22424

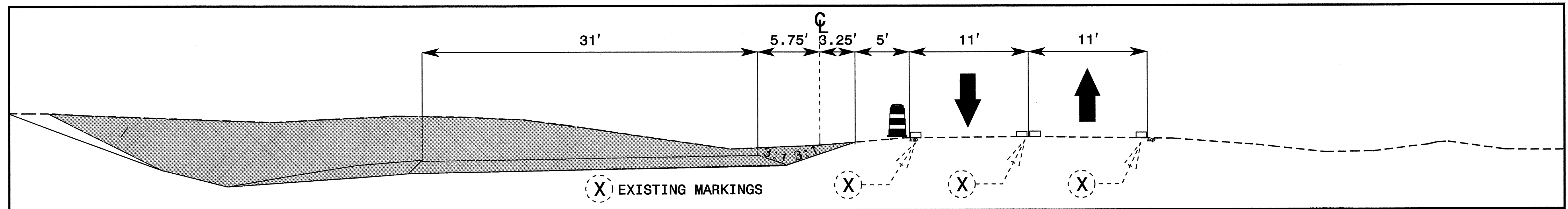
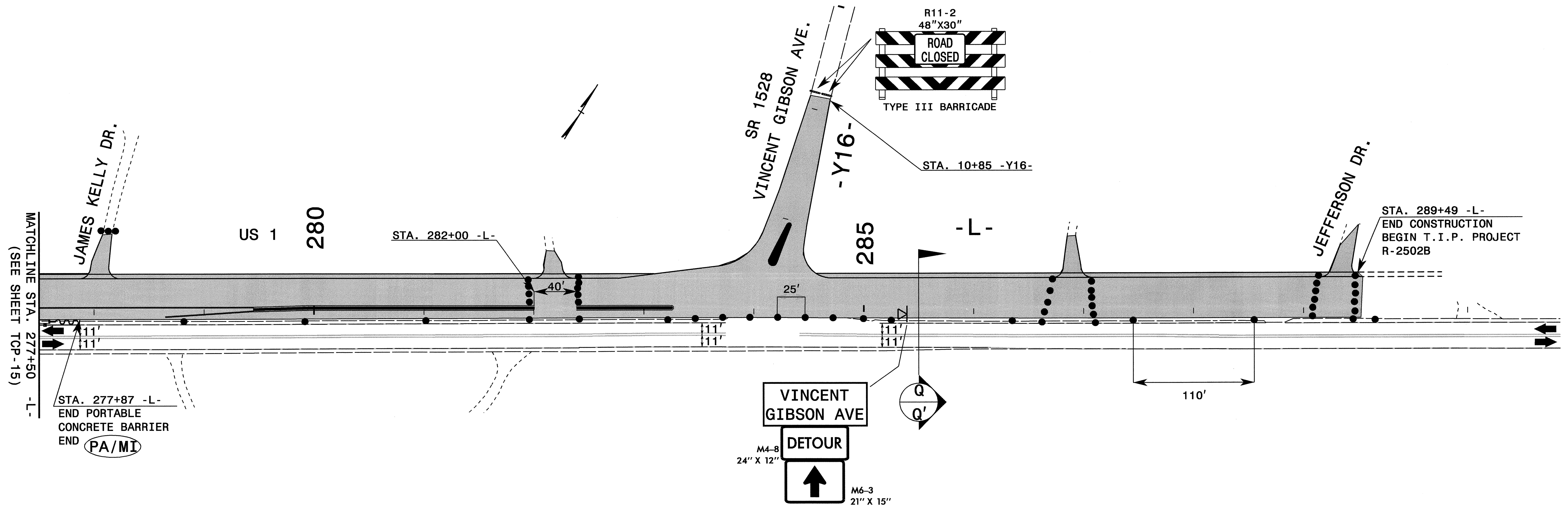

CUT SECTION Q
STA. 285+50 -L- Q'

- : PROPOSED PAVEMENT MARKING LINE
- : EXISTING PAVEMENT MARKING LINE
- ↪ : QA ↪ : QD ↪ : QG
- ↪ : QB ↪ : QE
- ↪ : QC ↪ : QF
- ↪ : EXISTING PAVEMENT MARKING SYMBOL

- FOR PAVEMENT MARKING SCHEDULE SEE SHEET TCP-4
- TEMPORARY RAISED PAVEMENT MARKERS SHALL BE PLACED IN ACCORDANCE WITH RSD 1250.05 AND 1251.01

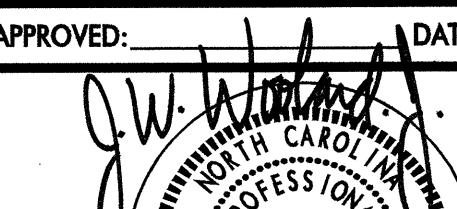
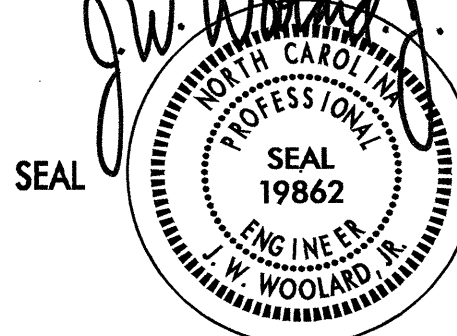
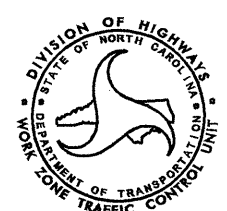
APPROVED: 	DATE: 2/19/08	PHASE I DETAIL	
SEAL 			
SCALE: NONE	DATE: 02/08		REVISIONS
DWG. BY: DAH	DESIGN BY: DAH		
REVIEWED BY: JWW			

19-FEB-2008 09:45
 \\dot\dfsroot\01\Proj\TIP\Projects-R\2502A\TrafficControl\Top\Phase I\NR-2502A-TC-TCP-Phil_16.dgn
 AT WZTC22424

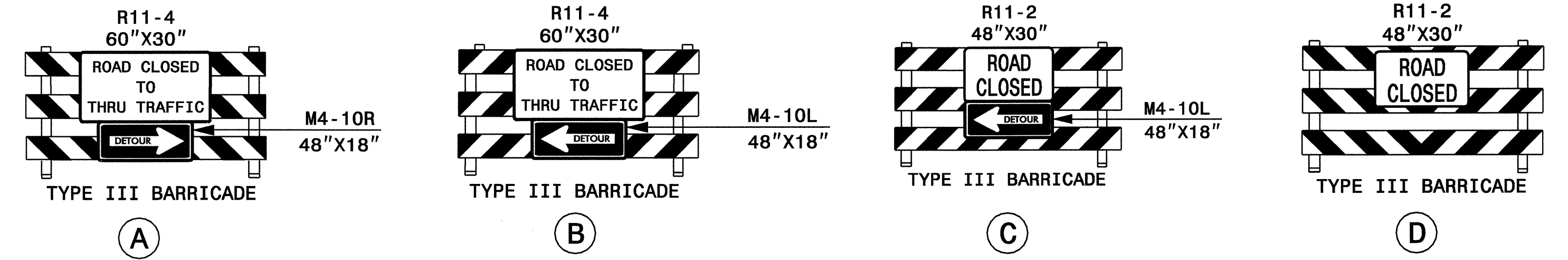
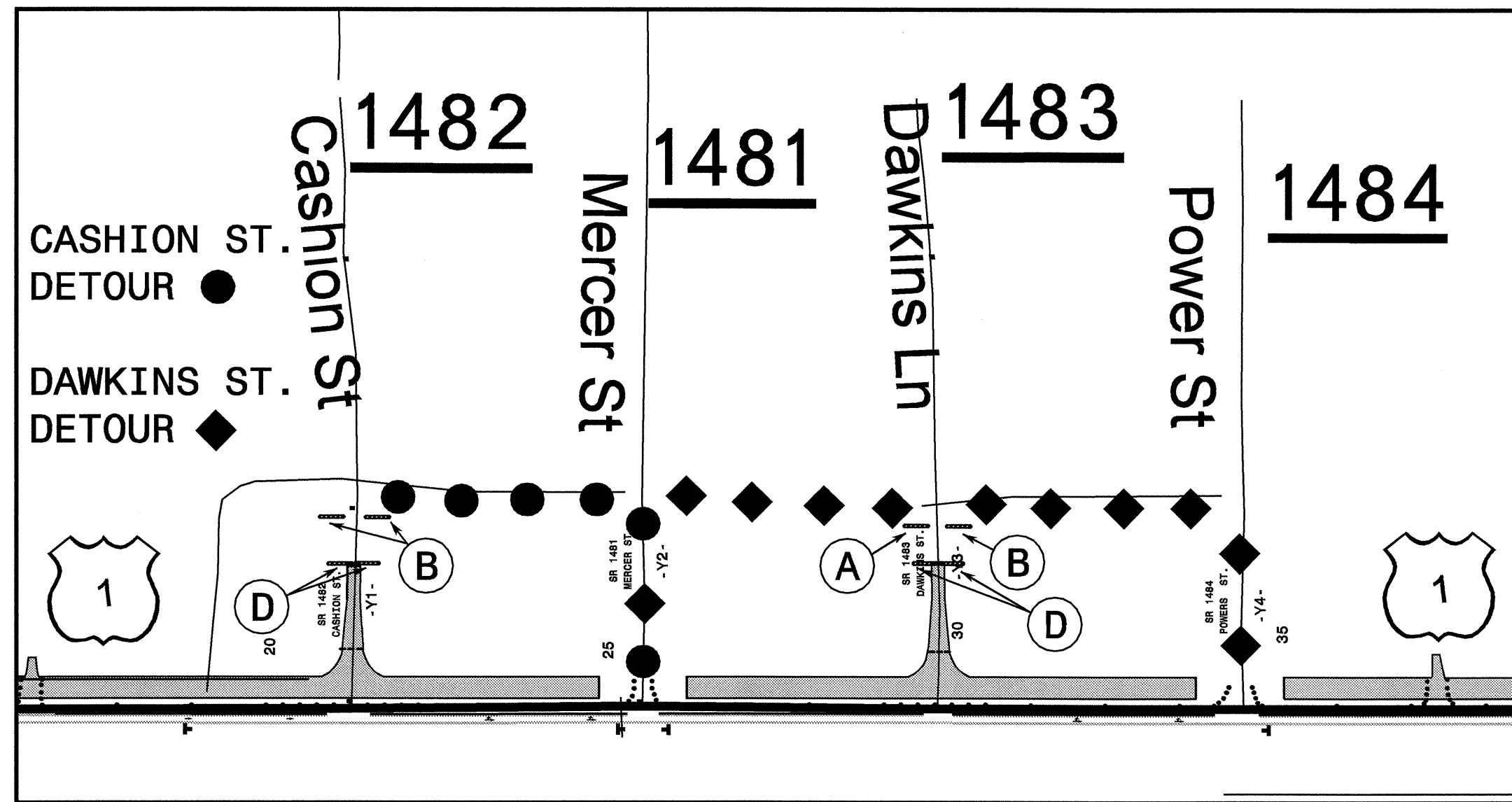

NOTE: SEE TCP-5, 7, 14, & 15 FOR OFFSITE DETOUR SIGNING.

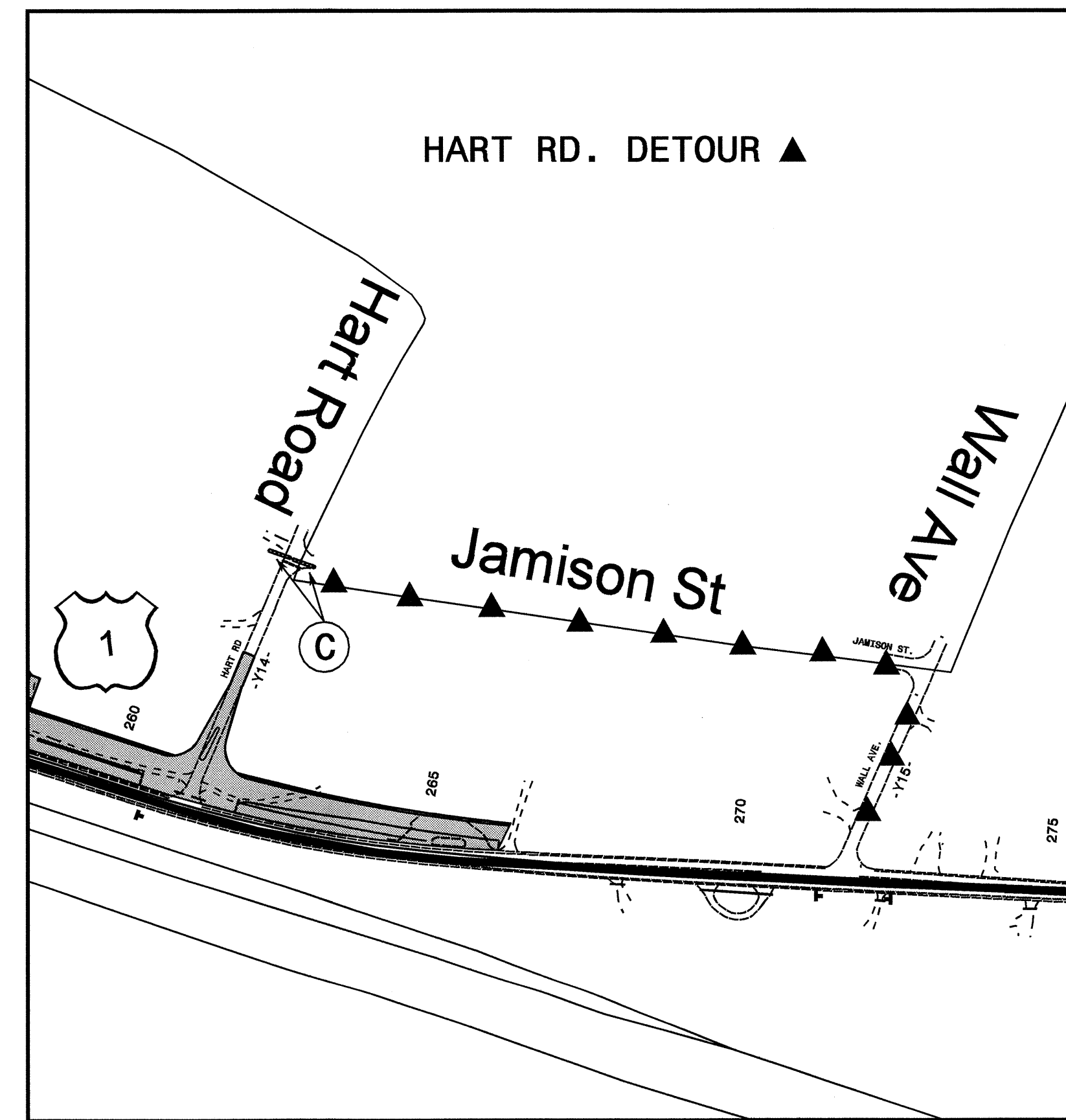
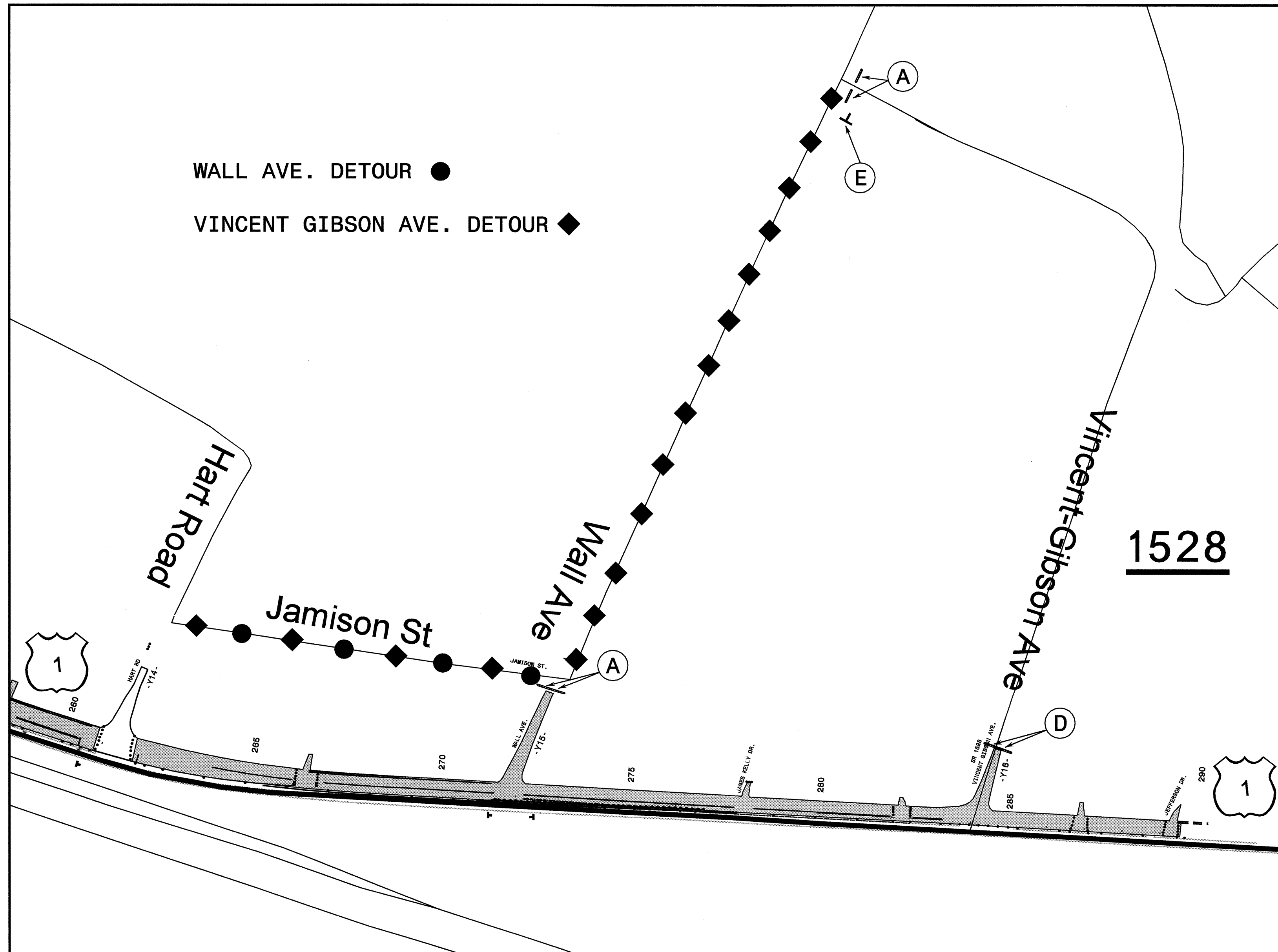
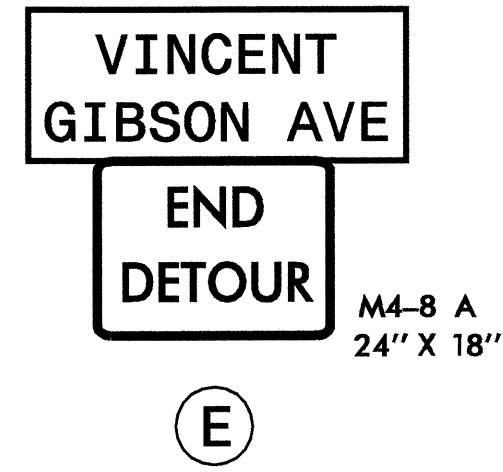

APPROVED:	DATE: 2/19/08	PHASE I DETAIL									
SCALE: NONE	DATE: 02/08										
DWG. BY: DAH	DESIGN BY: DAH	<table border="1"> <thead> <tr> <th colspan="2">REVISIONS</th> </tr> <tr> <th>NO.</th> <th>DESCRIPTION</th> </tr> </thead> <tbody> <tr> <td> </td> <td> </td> </tr> <tr> <td> </td> <td> </td> </tr> </tbody> </table>		REVISIONS		NO.	DESCRIPTION				
REVISIONS											
NO.	DESCRIPTION										
REVIEWED BY: JWW		CADD FILE									

19-FEB-2008 09:45
 \\dot\dfsroot\Pro\TIP\Projects-R\2502A\TrafficControl\Top\Phase I\NR-2502A_TC_TCP_PHLIT.OSD.dgn
 gdayes AT WZTC22424

SIGN NUMBER: SP07207
 TYPE: D
 QUANTITY: 1
 SIGN WIDTH: 48"
 HEIGHT: 14"
 TOTAL AREA: 4.7 Sq.Ft.
 BORDER TYPE: RECESSED
 RECESS: 0.38"
 WIDTH: 0.63"
 RADII: 1.5"
 NO. Z BARS: LENGTH:

BACKG COLOR: Fluorescent Orange
 COPY COLOR: Black

SYMBOL	X	Y	WID	HT

MAT'L: 0.125" (3.2 mm) ALUMINUM
 0.079" COMPOSITE

DESIGN BY: R. HENNEIN
 PROJECT ID: N/A
 CHECKED BY:
 DIV: N/A
 DATE: Jul 09, 2007

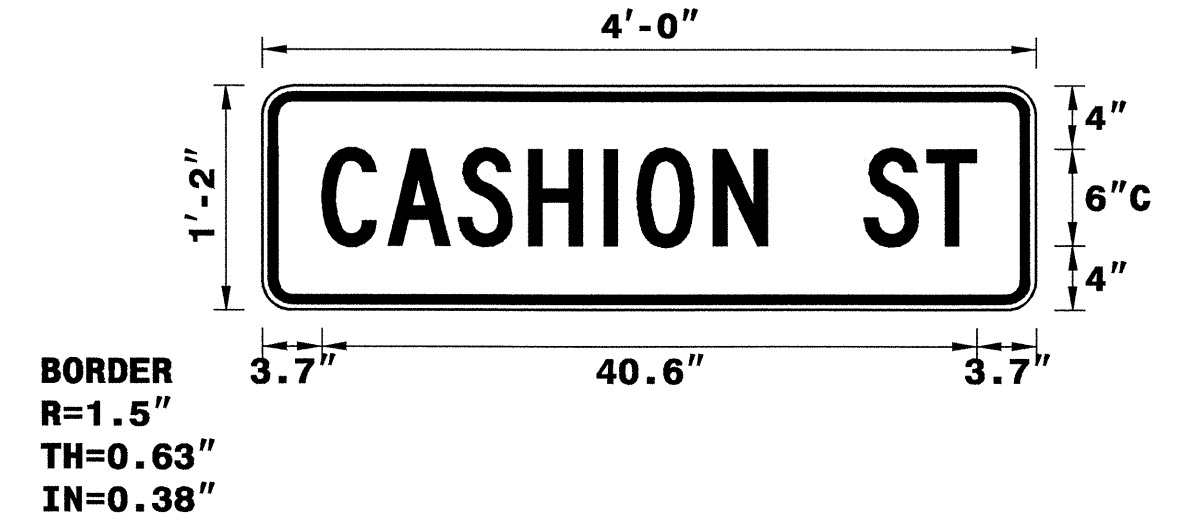

BORDER
 R=1.5"
 TH=0.63"
 IN=0.38"

Spacing Factor is 1 unless specified otherwise

USE NOTES:
 1. Legend and border shall be direct applied non-reflective sheeting.
 2. Background shall be Type VII, VIII, or IX (prismatic) retroreflective sheeting.

LETTER POSITIONS

Letter spacings are to start of next letter													Series/Size
													Text Length
	C	A	S	H	I	O	N	S	T				C 2000
	3.7	4.1	4.4	4.4	4.7	2	4.7	3.4	6	3.9	3.1	3.7	40.6

FILENAME: SP07207_cashionst NORTH CAROLINA D.O.T. SIGN DETAIL

SIGN NUMBER: SP07213
 TYPE: D
 QUANTITY: 1
 SIGN WIDTH: 36"
 HEIGHT: 14"
 TOTAL AREA: 3.5 Sq.Ft.
 BORDER TYPE: RECESSED
 RECESS: 0.38"
 WIDTH: 0.63"
 RADII: 1.5"
 NO. Z BARS: LENGTH:

BACKG COLOR: Fluorescent Orange
 COPY COLOR: Black

SYMBOL	X	Y	WID	HT

MAT'L: 0.080" (2.0 mm) ALUMINUM
 0.079" COMPOSITE

DESIGN BY: R. HENNEIN
 PROJECT ID: N/A
 CHECKED BY:
 DIV: N/A
 DATE: Jul 09, 2007

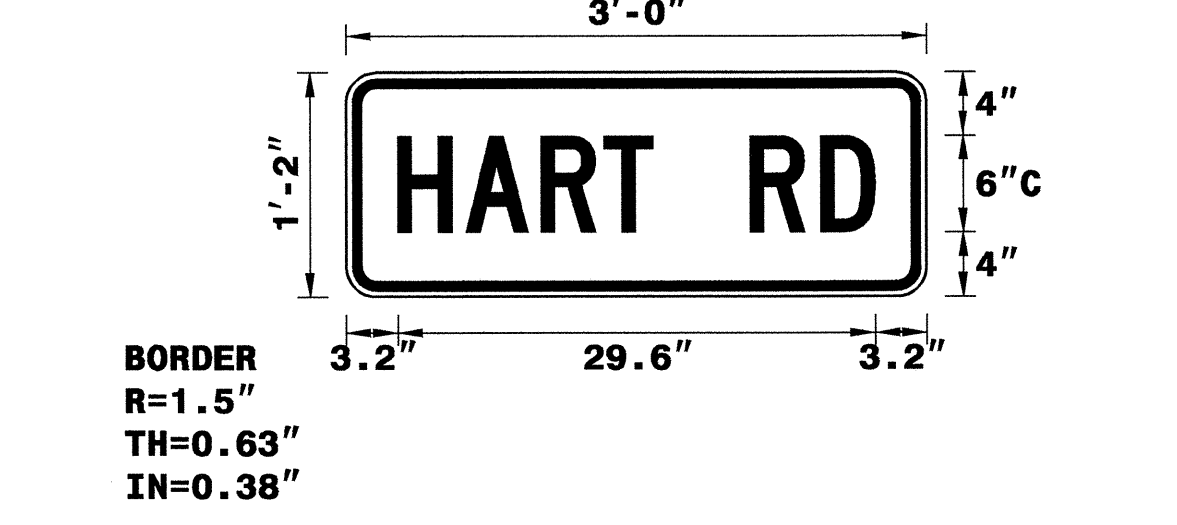

BORDER
 R=1.5"
 TH=0.63"
 IN=0.38"

Spacing Factor is 1 unless specified otherwise

USE NOTES:
 1. Legend and border shall be direct applied non-reflective sheeting.
 2. Background shall be Type VII, VIII, or IX (prismatic) retroreflective sheeting.

LETTER POSITIONS

Letter spacings are to start of next letter													Series/Size
													Text Length
	H	A	R	T	R	D							C 2000
	3.2	4.2	4.7	3.9	3.1	6	4.4	3.4	3.2				29.6

FILENAME: SP07213_hartrd NORTH CAROLINA D.O.T. SIGN DETAIL

SIGN NUMBER: SP07208
 TYPE: D
 QUANTITY: 1
 SIGN WIDTH: 48"
 HEIGHT: 14"
 TOTAL AREA: 4.7 Sq.Ft.
 BORDER TYPE: RECESSED
 RECESS: 0.38"
 WIDTH: 0.63"
 RADII: 1.5"
 NO. Z BARS: LENGTH:

BACKG COLOR: Fluorescent Orange
 COPY COLOR: Black

SYMBOL	X	Y	WID	HT

MAT'L: 0.125" (3.2 mm) ALUMINUM
 0.079" COMPOSITE

DESIGN BY: R. HENNEIN
 PROJECT ID: N/A
 CHECKED BY:
 DIV: N/A
 DATE: Jul 09, 2007

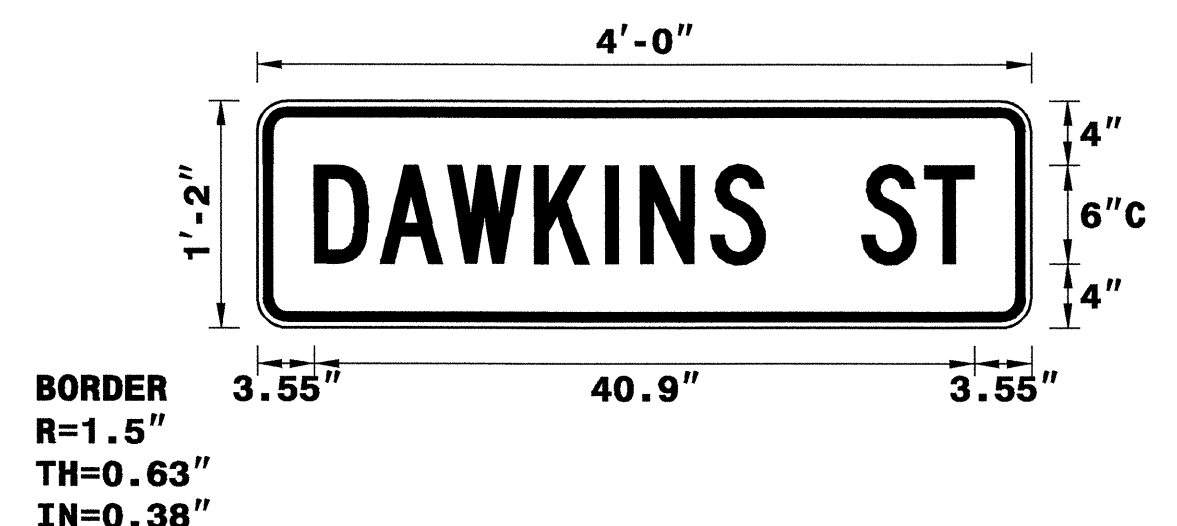

BORDER
 R=1.5"
 TH=0.63"
 IN=0.38"

Spacing Factor is 1 unless specified otherwise

USE NOTES:
 1. Legend and border shall be direct applied non-reflective sheeting.
 2. Background shall be Type VII, VIII, or IX (prismatic) retroreflective sheeting.

LETTER POSITIONS

Letter spacings are to start of next letter													Series/Size
													Text Length
	D	A	W	K	I	N	S	S	T				C 2000
	3.5	4.1	4.2	5.4	4.4	2.2	4.4	3.4	6	3.9	3.1	3.5	40.9

FILENAME: SP07208_dawkinsst NORTH CAROLINA D.O.T. SIGN DETAIL

SIGN NUMBER: SP07211
 TYPE: D
 QUANTITY: 1
 SIGN WIDTH: 48"
 HEIGHT: 24"
 TOTAL AREA: 8.0 Sq.Ft.
 BORDER TYPE: RECESSED
 RECESS: 0.38"
 WIDTH: 0.63"
 RADII: 1.5"
 NO. Z BARS: LENGTH:

BACKG COLOR: Fluorescent Orange
 COPY COLOR: Black

SYMBOL	X	Y	WID	HT

MAT'L: 0.125" (3.2 mm) ALUMINUM
 0.079" COMPOSITE

DESIGN BY: R. HENNEIN
 PROJECT ID: N/A
 CHECKED BY:
 DIV: N/A
 DATE: Jul 09, 2007

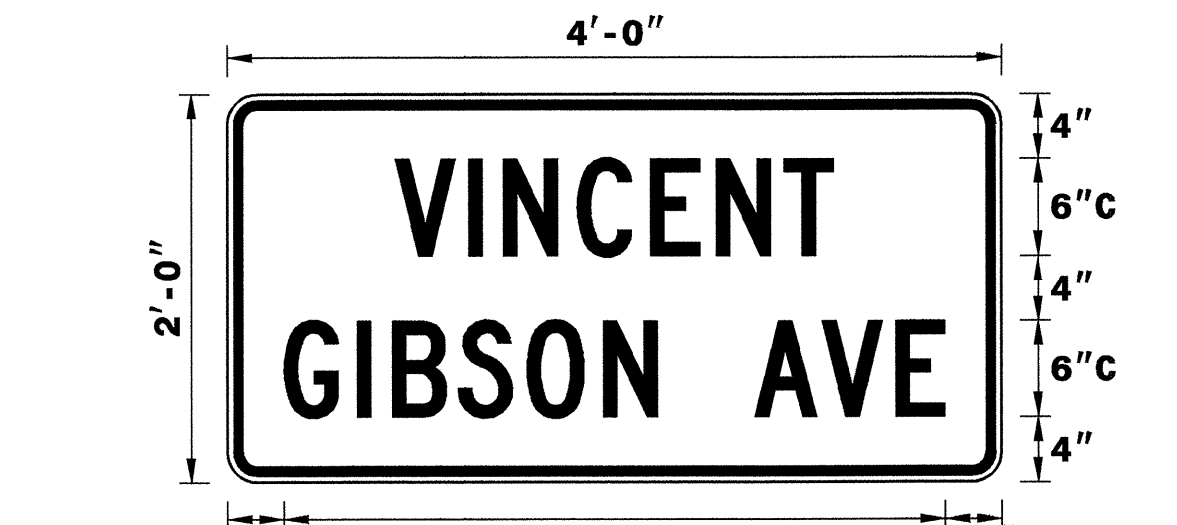

BORDER
 R=1.5"
 TH=0.63"
 IN=0.38"

Spacing Factor is 1 unless specified otherwise

USE NOTES:
 1. Legend and border shall be direct applied non-reflective sheeting.
 2. Background shall be Type VII, VIII, or IX (prismatic) retroreflective sheeting.

LETTER POSITIONS

Letter spacings are to start of next letter													Series/Size
													Text Length
	V	I	N	C	E	N	T						C 2000
	10.4	4.6	2.2	4.6	4.6	4.1	4.2	3.1	10.4				27.2
	G	I	B	S	O	N	A	V	E				C 2000
	3.5	4.6	2.2	4.1	4.3	4.7	3.4	6	4.2	4.6	3.1	3.5	41

FILENAME: SP07211_vincentgibsonave NORTH CAROLINA D.O.T. SIGN DETAIL

SIGN NUMBER: SP07212
 TYPE: D
 QUANTITY: 1
 SIGN WIDTH: 42"
 HEIGHT: 14"
 TOTAL AREA: 4.1 Sq.Ft.
 BORDER TYPE: RECESSED
 RECESS: 0.38"
 WIDTH: 0.63"
 RADII: 1.5"
 NO. Z BARS: LENGTH:

BACKG COLOR: Fluorescent Orange
 COPY COLOR: Black

SYMBOL	X	Y	WID	HT

MAT'L: 0.080" (2.0 mm) ALUMINUM
 0.079" COMPOSITE

DESIGN BY: R. HENNEIN
 PROJECT ID: N/A
 CHECKED BY:
 DIV: N/A
 DATE: Jul 09, 2007

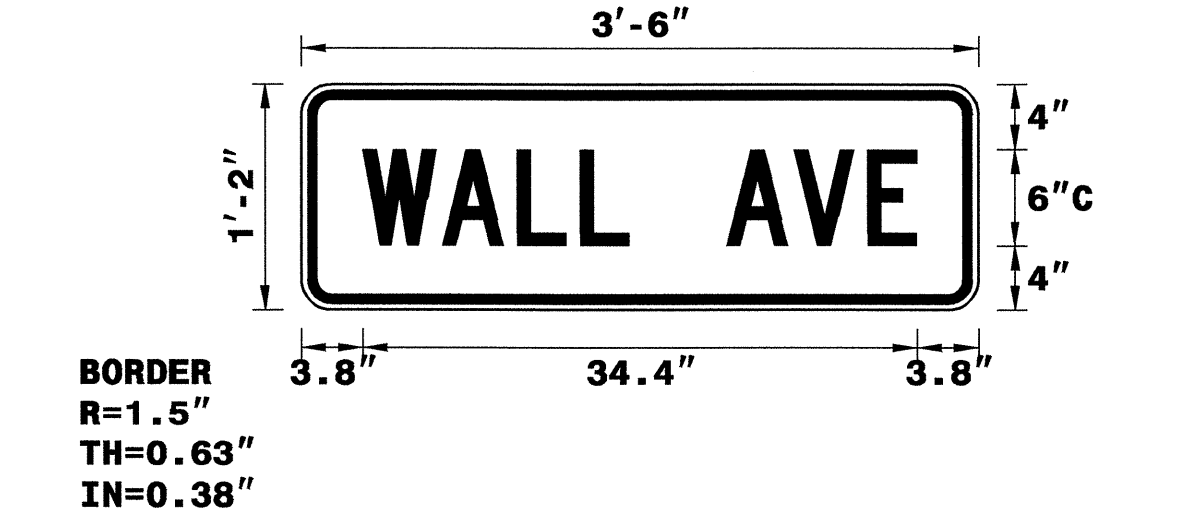

BORDER
 R=1.5"
 TH=0.63"
 IN=0.38"

Spacing Factor is 1 unless specified otherwise

USE NOTES:
 1. Legend and border shall be direct applied non-reflective sheeting.
 2. Background shall be Type VII, VIII, or IX (prismatic) retroreflective sheeting.

LETTER POSITIONS

Letter spacings are to start of next letter													Series/Size
													Text Length
	W	A	L	L	A	V	E						C 2000
	3.8	4.9	4.7	3.9	3.1	6	4.2	4.6	3.1	3.8			34.4

FILENAME: SP07212_wallave NORTH CAROLINA D.O.T. SIGN DETAIL

APPROVED: _____ DATE: _____

2/19/08

PHASE I DETAIL

SCALE: NONE		REVISIONS
DATE: 1/4		
DWG. BY: DAH		
DESIGN BY: DAH		
REVIEWED BY: JWW		

19-FEB-2008 11:36
 \\dot\dfs\0010\Proj\IP\Projects-R\2502A\TrafficControl\Top\Phase I\R-2502A_TC_TCP_Philita_SignDsgn.dgn
 at WZTC2424

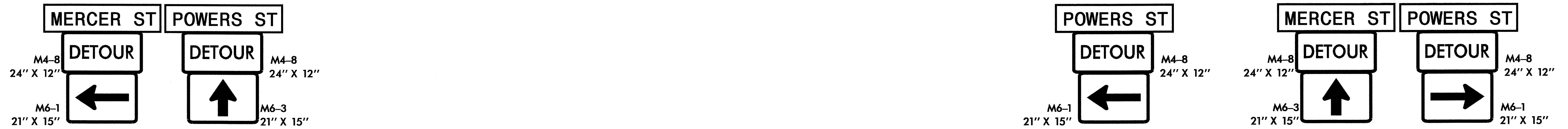
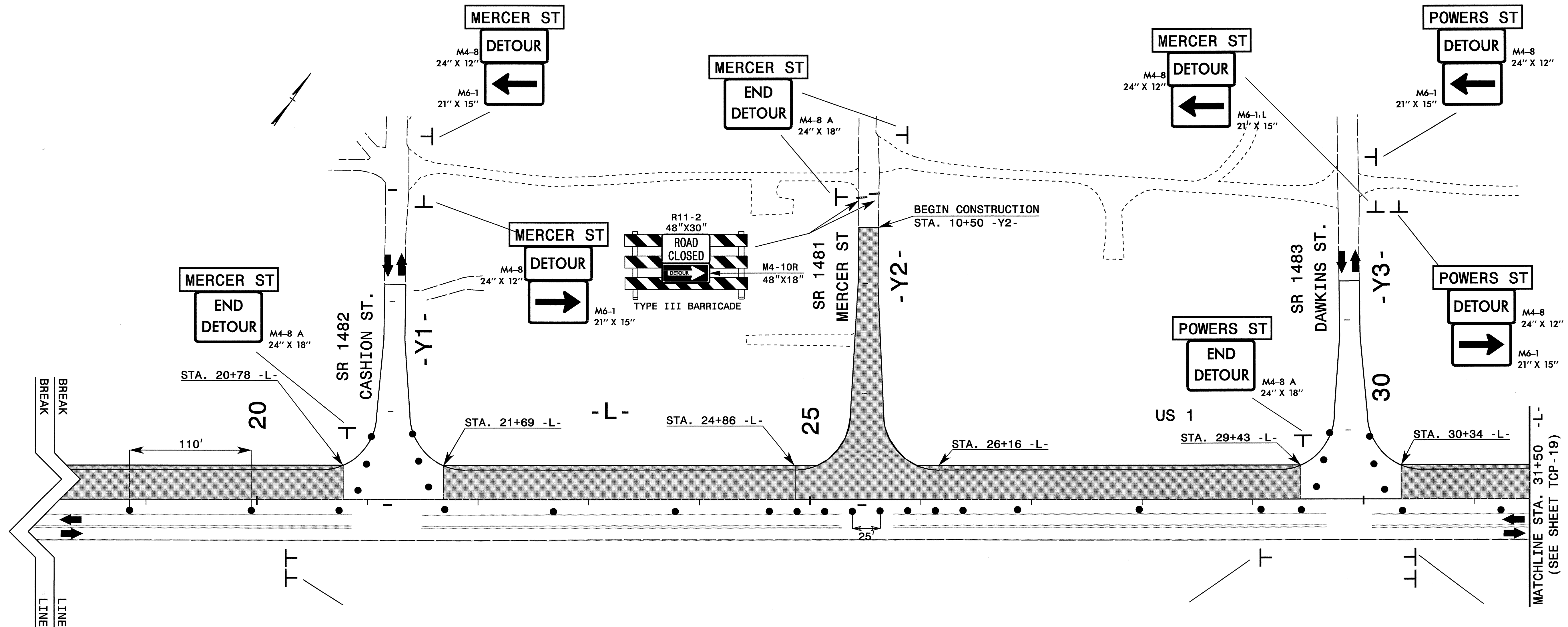

- : PROPOSED PAVEMENT MARKING LINE
- : EXISTING PAVEMENT MARKING LINE
- ↪ : QA ↪ : QD ↪ : QG
- ↪ : QB ↪ : QE
- ↪ : QC ↪ : QF
- ↪ : EXISTING PAVEMENT MARKING SYMBOL

ON-GOING CONSTRUCTION

- FOR PAVEMENT MARKING SCHEDULE SEE SHEET TCP-4
- TEMPORARY RAISED PAVEMENT MARKERS SHALL BE PLACED IN ACCORDANCE WITH RSD 1250.05 AND 1251.01

APPROVED:	DATE: 2/19/08	PHASE II DETAIL	
SEAL			
SCALE: NONE	DATE: 02/08		REVISIONS
DWG. BY: DAH	DESIGN BY: DAH		
REVIEWED BY: JWW			

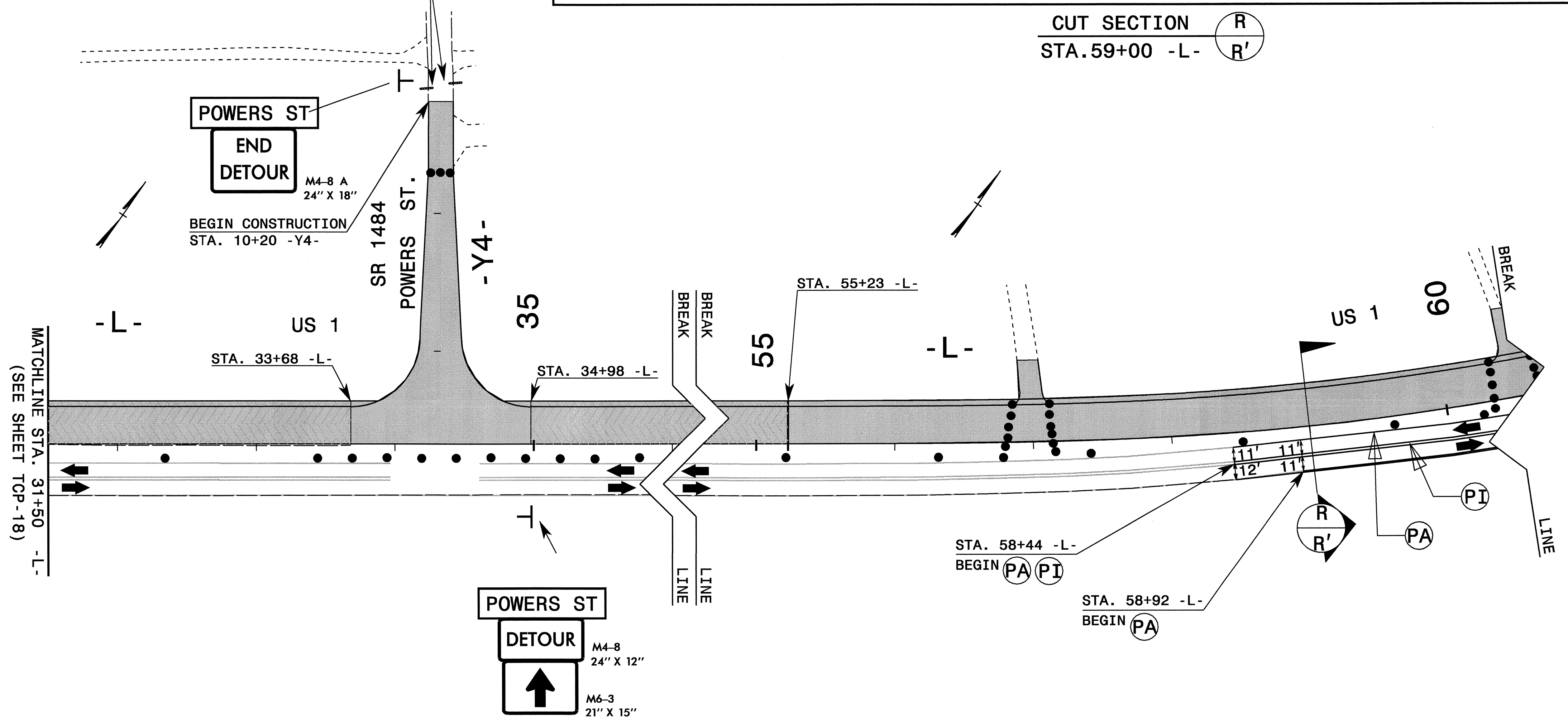
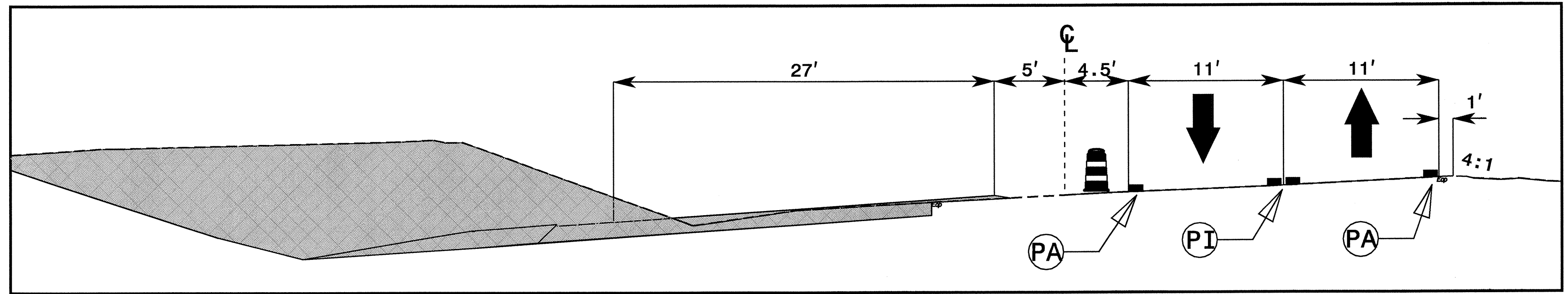
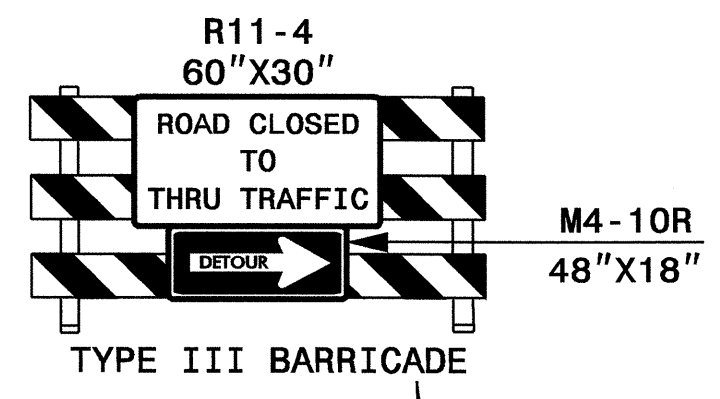

- : PROPOSED PAVEMENT MARKING LINE
- : EXISTING PAVEMENT MARKING LINE
- ↪ : QA ↪ : QD ↪ : QG
- ↪ : QB ↪ : QE
- ↪ : QC ↪ : QF
- ↪ : EXISTING PAVEMENT MARKING SYMBOL

ON-GOING CONSTRUCTION

- FOR PAVEMENT MARKING SCHEDULE SEE SHEET TCP-4
- TEMPORARY RAISED PAVEMENT MARKERS SHALL BE PLACED IN ACCORDANCE WITH RSD 1250.05 AND 1251.01

APPROVED:	DATE: 2/19/08	PHASE II DETAIL	
SEAL 			
SCALE: NONE	DATE: 02/08		
DESIGN BY: DAH	REVIEWED BY: JWW		
REVISIONS			

19-FEB-2008 09:43
 \\dot\dfs\p0010\Proj\TIP\Projects-RAR2502A\TrafficControl\top\Phase I\NR-2502A_TC_TCP_Phil_L19.dgn
 ahayes AT WZTC22424

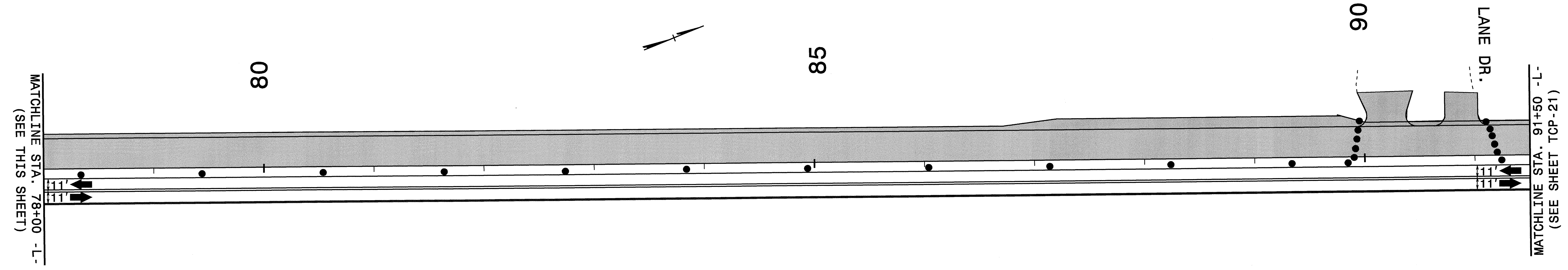
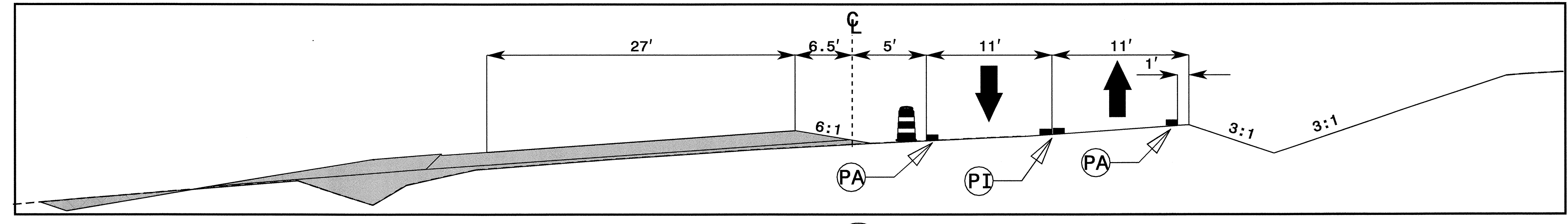
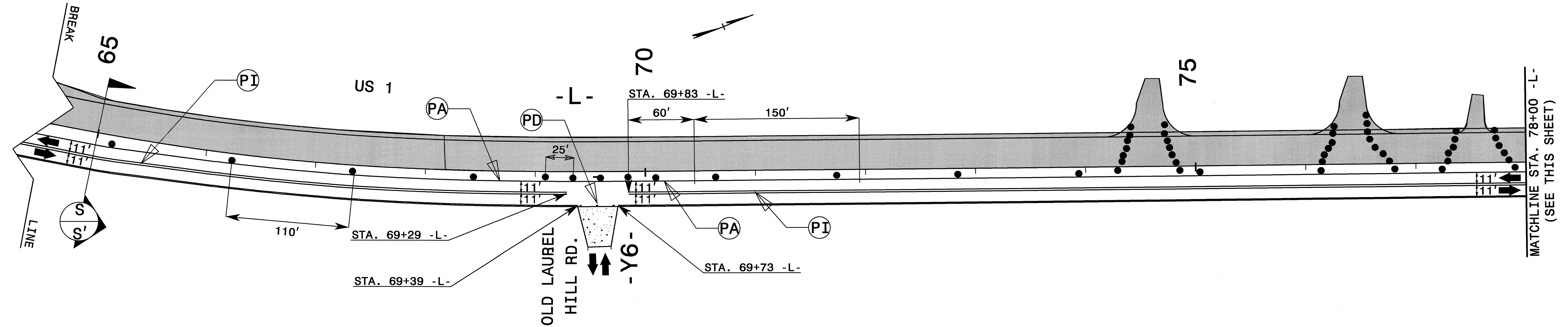

- : PROPOSED PAVEMENT MARKING LINE
- : EXISTING PAVEMENT MARKING LINE
- ↪ : QA ↻ : QD ↻ : QG
- ↪ : QB ↻ : QE
- ↪ : QC ↻ : QF
- ↪ : EXISTING PAVEMENT MARKING SYMBOL

- FOR PAVEMENT MARKING SCHEDULE SEE SHEET TCP-4
- TEMPORARY RAISED PAVEMENT MARKERS SHALL BE PLACED IN ACCORDANCE WITH RSD 1250.05 AND 1251.01

APPROVED: _____ SEAL	DATE: 2/19/08	PHASE II DETAIL	
SCALE: NONE		REVISIONS	
DATE: 02/08			
DWG. BY: DAH			
DESIGN BY: DAH			
REVIEWED BY: JWW			

1-FEB-2008 09:43
 \\dot\dfsroot\proj\proj\Traffic\TrafficControl\Top\Phase II\R-2502A_TC-TCP_PHLI_20.dgn
 ingves AT WZTC224241

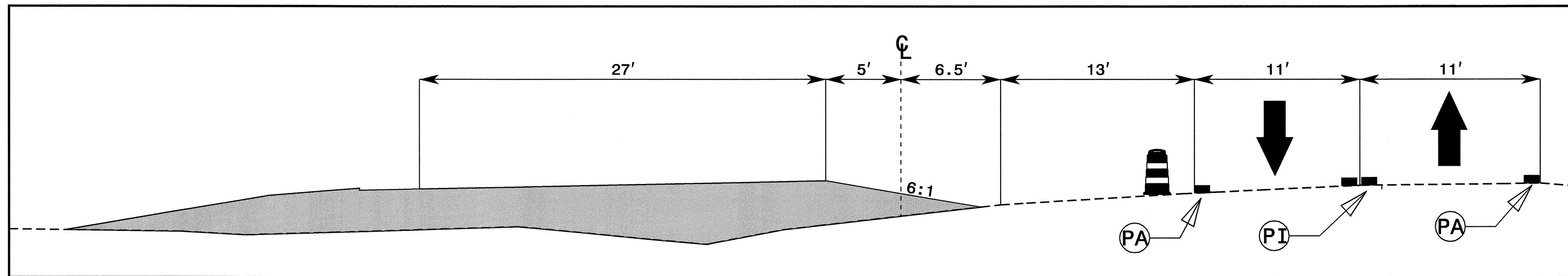
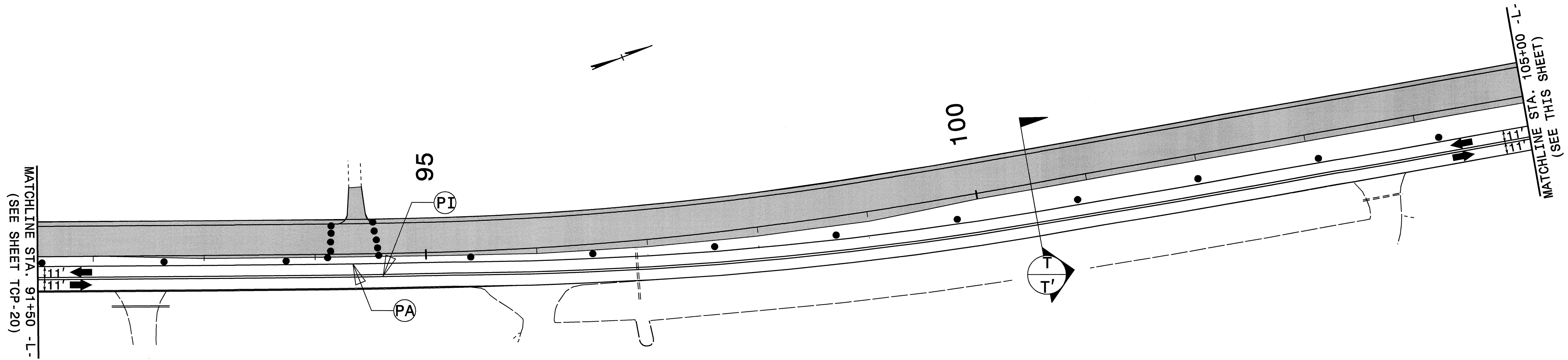

CUT SECTION
STA. 100+50 -L-

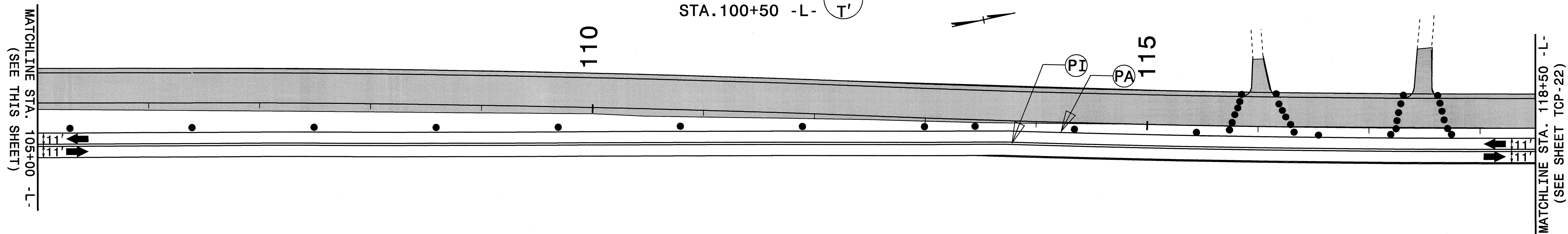

- : PROPOSED PAVEMENT MARKING LINE
- : EXISTING PAVEMENT MARKING LINE
- ↪ : QA ↪ : QD ↪ : QG
- ↪ : QB ↪ : QE
- ↪ : QC ↪ : QF
- ↪ : EXISTING PAVEMENT MARKING SYMBOL

- FOR PAVEMENT MARKING SCHEDULE SEE SHEET TCP-4
- TEMPORARY RAISED PAVEMENT MARKERS SHALL BE PLACED IN ACCORDANCE WITH RSD 1250.05 AND 1251.01

APPROVED: _____ DATE: _____	PHASE II DETAIL							
	SCALE: NONE							
	DATE: 02/08							
	DESIGN BY: DAH							
	REVIEWED BY: JWW							
		<table border="1"> <tr> <th colspan="2">REVISIONS</th> </tr> <tr> <td> </td> <td> </td> </tr> <tr> <td> </td> <td> </td> </tr> </table>	REVISIONS					
REVISIONS								

I9-FEB-2008 09:42
 \\dot\gfsr\root\0\Proj\TipProjects-R\2502A\Traffic\TrafficControl\top\Phase II\NR-2502A_TC_TCP_Phil_21.dgn
 dahyes AT WZTC224241

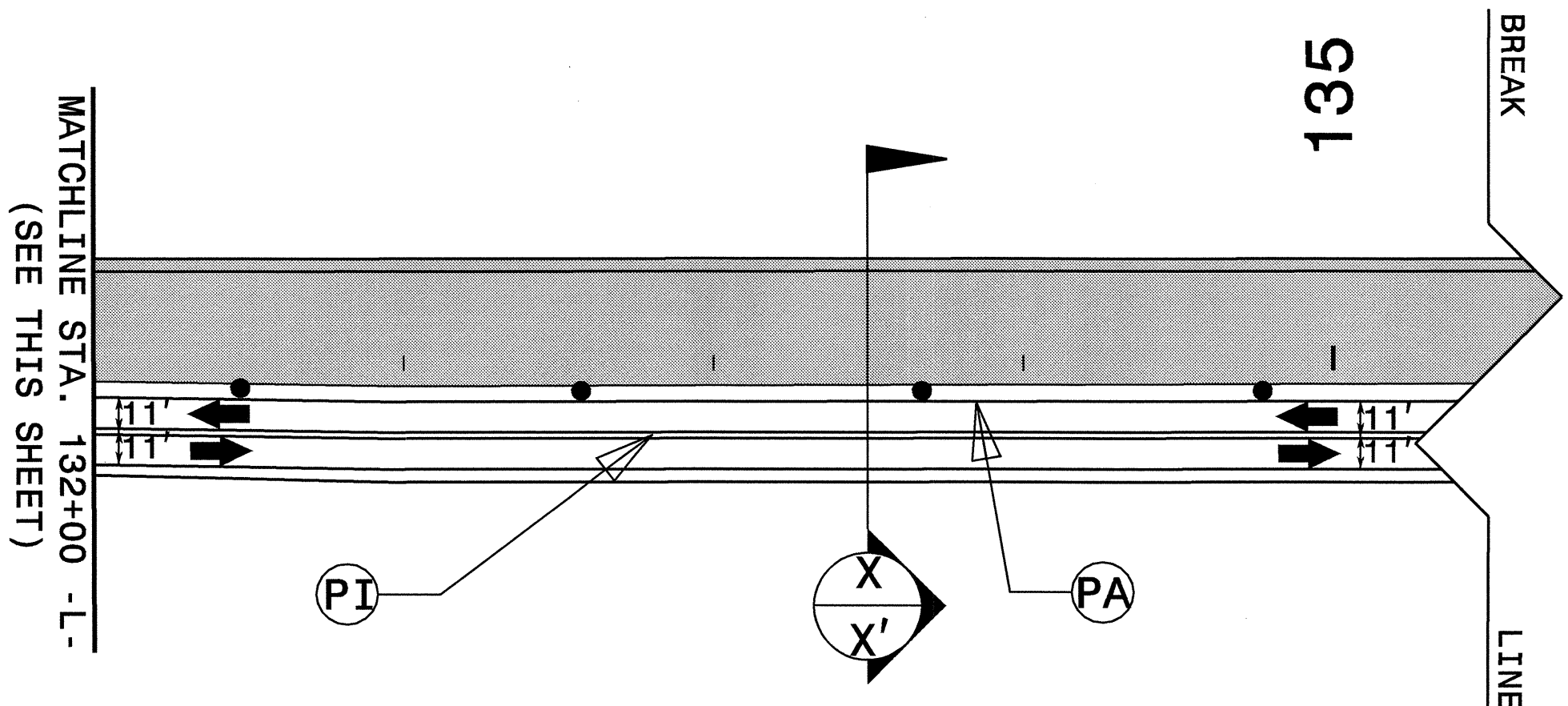
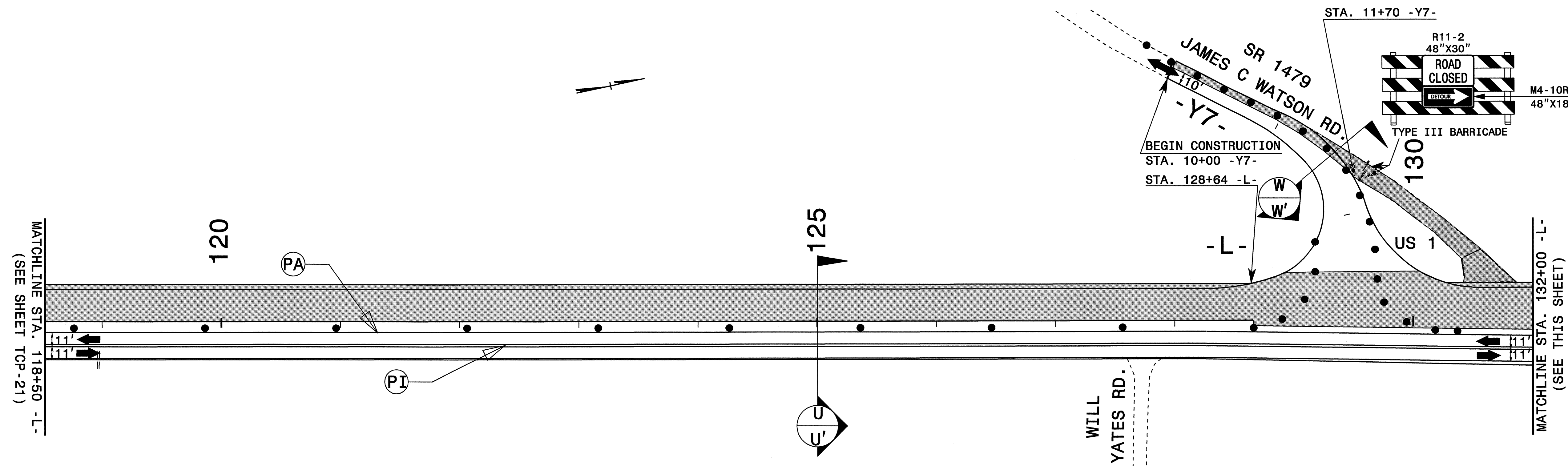

- : PROPOSED PAVEMENT MARKING LINE
- : EXISTING PAVEMENT MARKING LINE
- ↪ : QA ↪ : QD ↪ : QG
- ↪ : QB ↪ : QE
- ↪ : QC ↪ : QF
- ↪ : EXISTING PAVEMENT MARKING SYMBOL

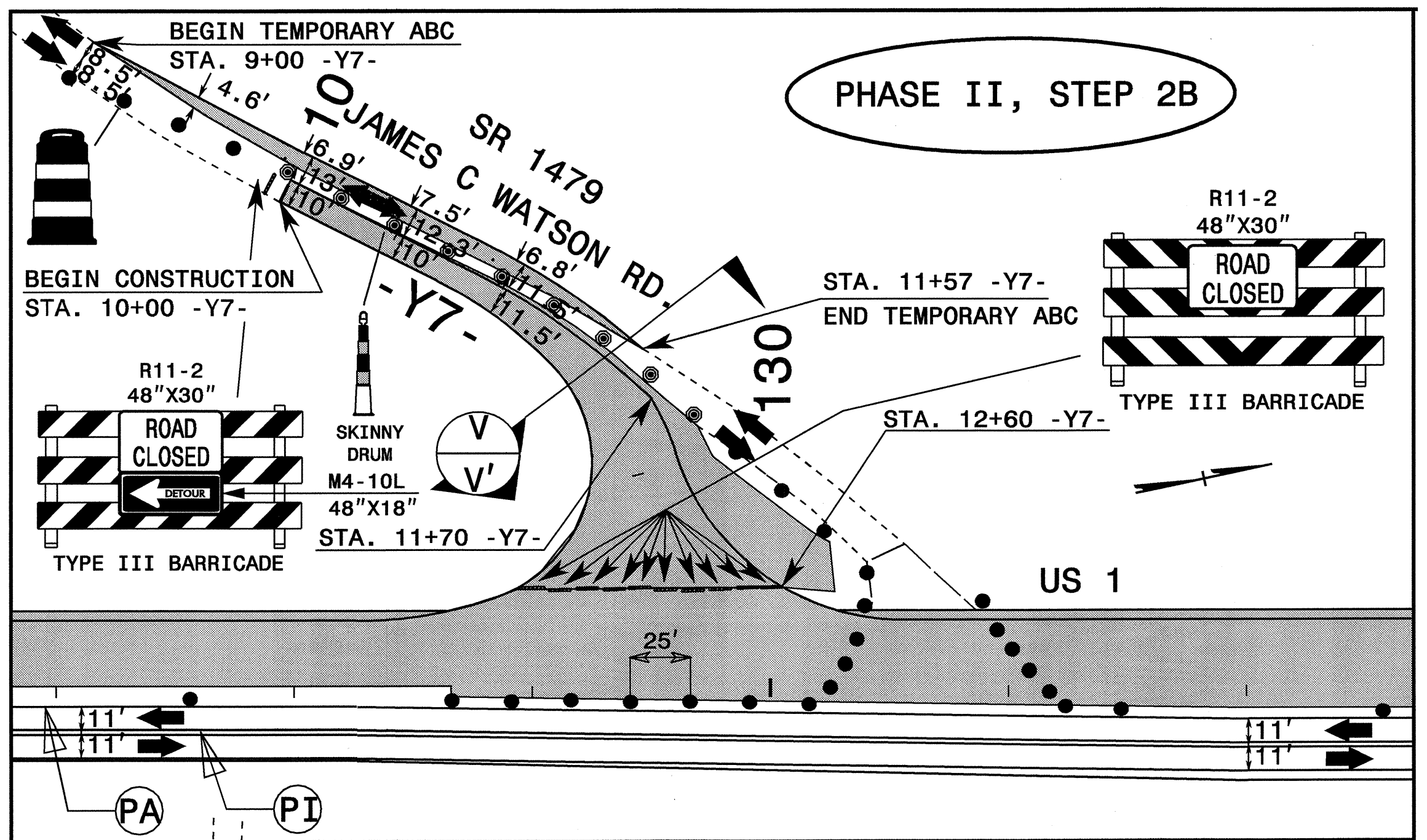

FOR SECTIONAL VIEWS U-U', V-V', W-W', AND X-X' SEE SHEET TCP-23.

- FOR PAVEMENT MARKING SCHEDULE SEE SHEET TCP-4
- TEMPORARY RAISED PAVEMENT MARKERS SHALL BE PLACED IN ACCORDANCE WITH RSD 1250.05 AND 1251.01

APPROVED:	DATE: 2/19/08	PHASE II DETAIL	
SCALE: NONE	DATE: 02/08		
DWG. BY: DAH	DESIGN BY: DAH		REVISIONS
REVIEWED BY: JWW	CADD FILE		

19-FEB-2008 09:42
 \\dot\dfsroot\proj\11\proj\projects-r\2502A\TrafficControl\Top\Phase II\R-2502A_TC_TCP_Phil_22.dgn
 ahaves AT WZTC22424

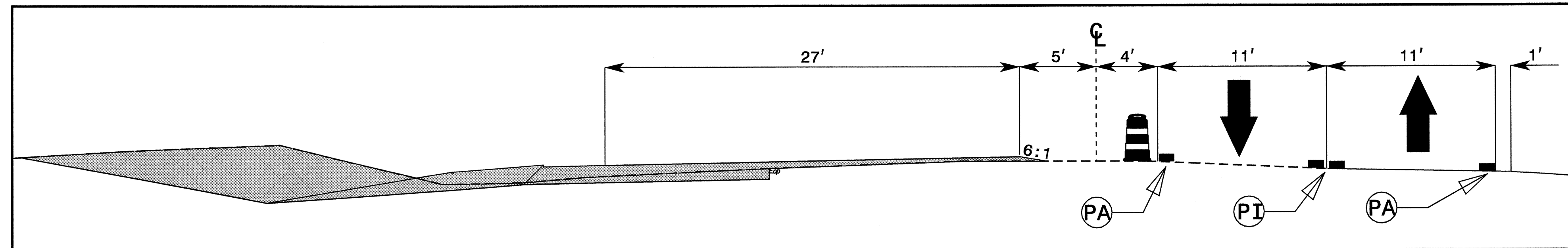

CUT SECTION $\frac{U}{U'}$
STA. 125+00 -L-

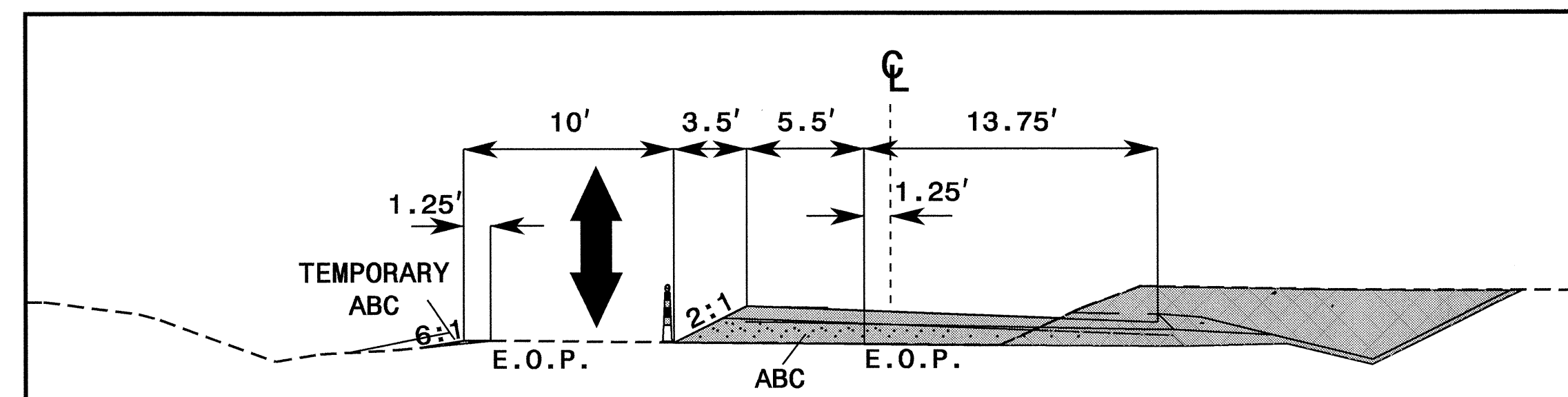

CUT SECTION $\frac{V}{V'}$
STA. 11+50 -Y7-
PHASE II, STEP 2B

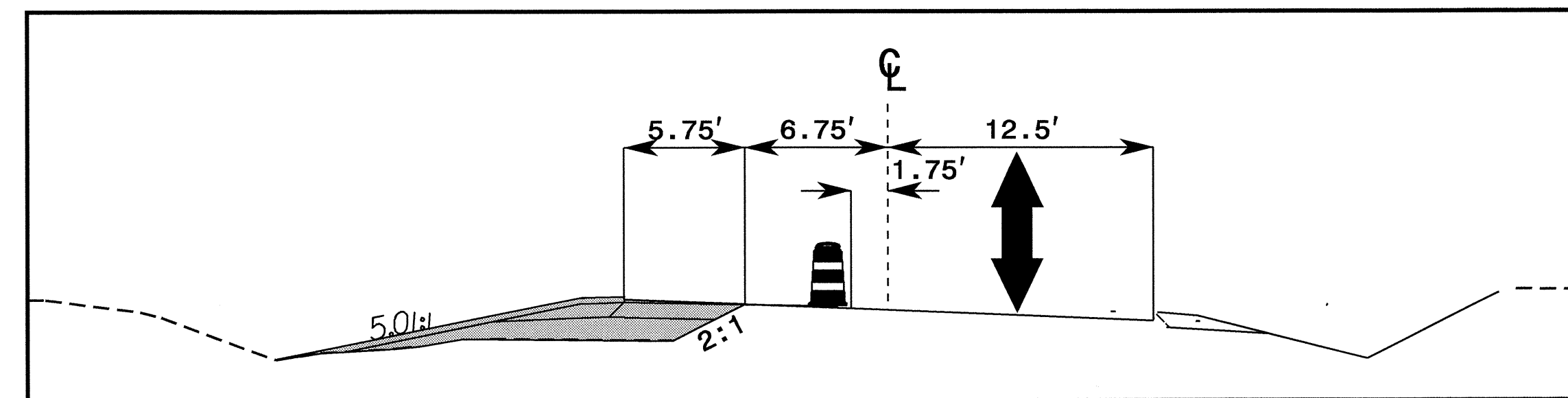

CUT SECTION $\frac{W}{W'}$
STA. 11+50 -Y7-

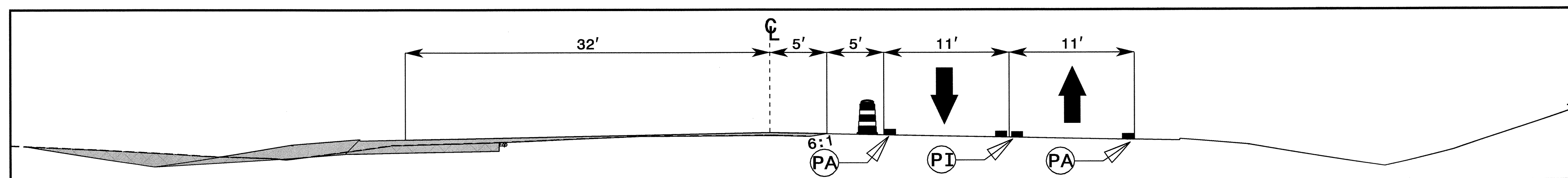

CUT SECTION $\frac{X}{X'}$
STA. 133+50 -L-

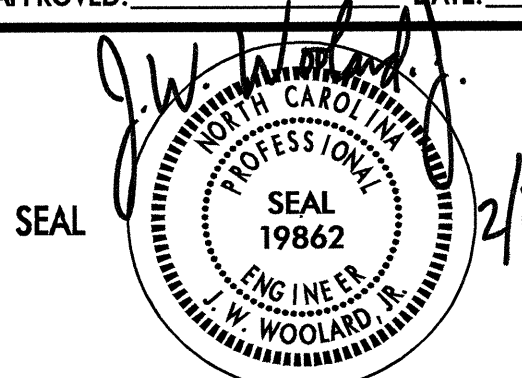
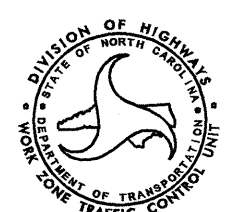
APPROVED: _____ DATE: _____	PHASE II DETAIL									
										
SCALE: NONE	DATE: 02/08	<table border="1"> <thead> <tr> <th colspan="2">REVISIONS</th> </tr> </thead> <tbody> <tr> <td> </td> <td> </td> </tr> <tr> <td> </td> <td> </td> </tr> <tr> <td> </td> <td> </td> </tr> </tbody> </table>	REVISIONS							
REVISIONS										
DWG. BY: DAH	DESIGN BY: DAH									
REVIEWED BY: JWW										

I9-FEB-2008 09:41
 \\dot\dfsroot\Pro\TIPProjects-R\2502A\TrafficControl\Phase II\R-2502A-TC-TCP_Phil_23.dgn
 dahyes AT WZTC224241

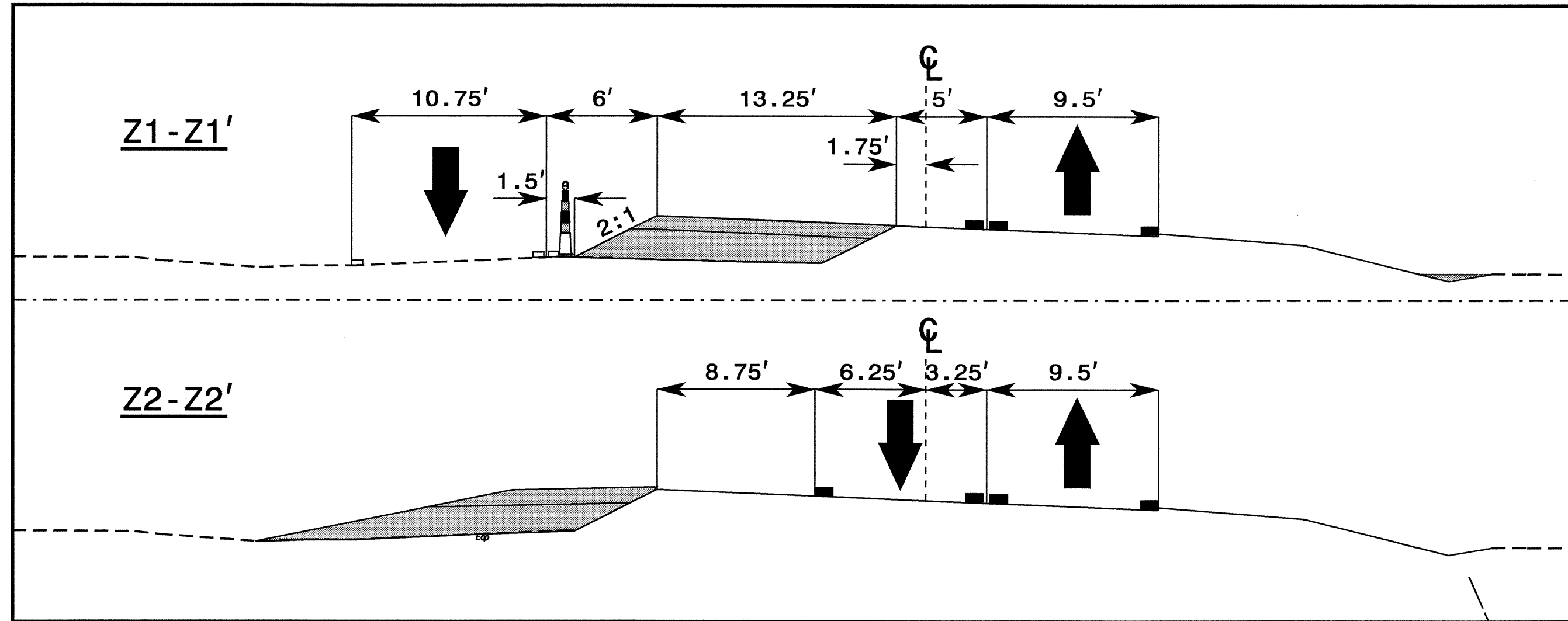

CUT SECTION
STA. 13+50 -Y8-

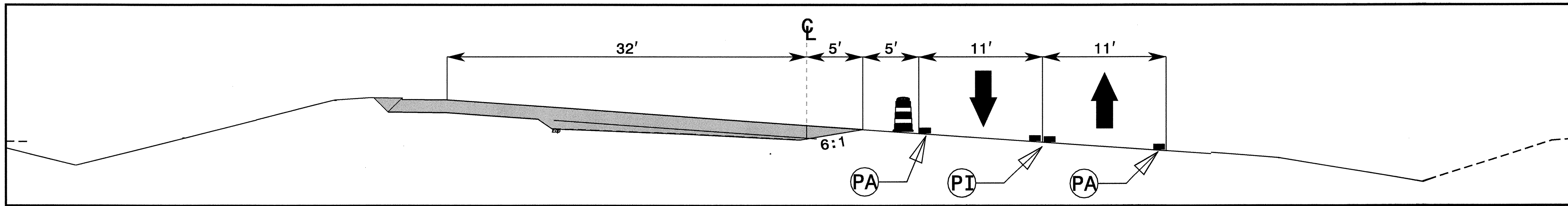
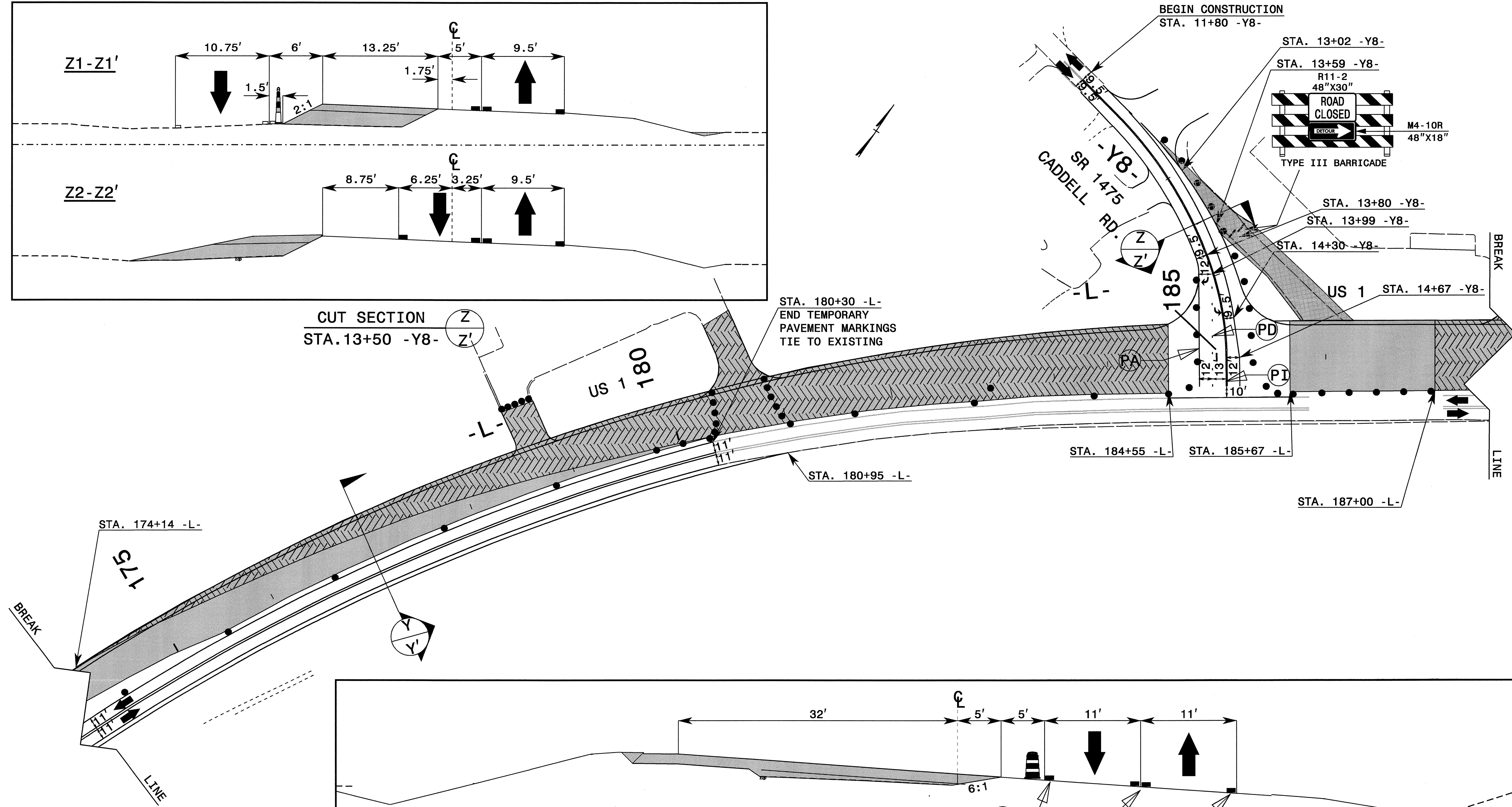

CUT SECTION
STA. 177+00 -L-

- : PROPOSED PAVEMENT MARKING LINE
 - : EXISTING PAVEMENT MARKING LINE
 - ↪ : QA ↪ : QB ↪ : QC ↪ : QD ↪ : QE ↪ : QF ↪ : QG
 - ↪ : EXISTING PAVEMENT MARKING SYMBOL
 - PAVEMENT REMOVAL
 - ON-GOING CONSTRUCTION
- FOR PAVEMENT MARKING SCHEDULE SEE SHEET TCP-4
● TEMPORARY RAISED PAVEMENT MARKERS SHALL BE PLACED IN ACCORDANCE WITH RSD 1250.05 AND 1251.01

APPROVED: _____ DATE: 2/19/08

SEAL

PROFESSIONAL SEAL 19862

ENGINEER

W. WOOLARD, JR.

PHASE II DETAIL

SCALE: NONE		REVISIONS
DATE: 02/08		
DESIGN BY: DAH		
REVIEWED BY: JWW		

CADD FILE

19-FEB-2008 09:41
 \\dot\dfs\p00\0\Pro\1\IP\Projects-R\2502A\Traffic\TrafficControl\Top\Phase II\R-2502A-TC-TCP_Phil_24.dgn
 AT WZTC224241

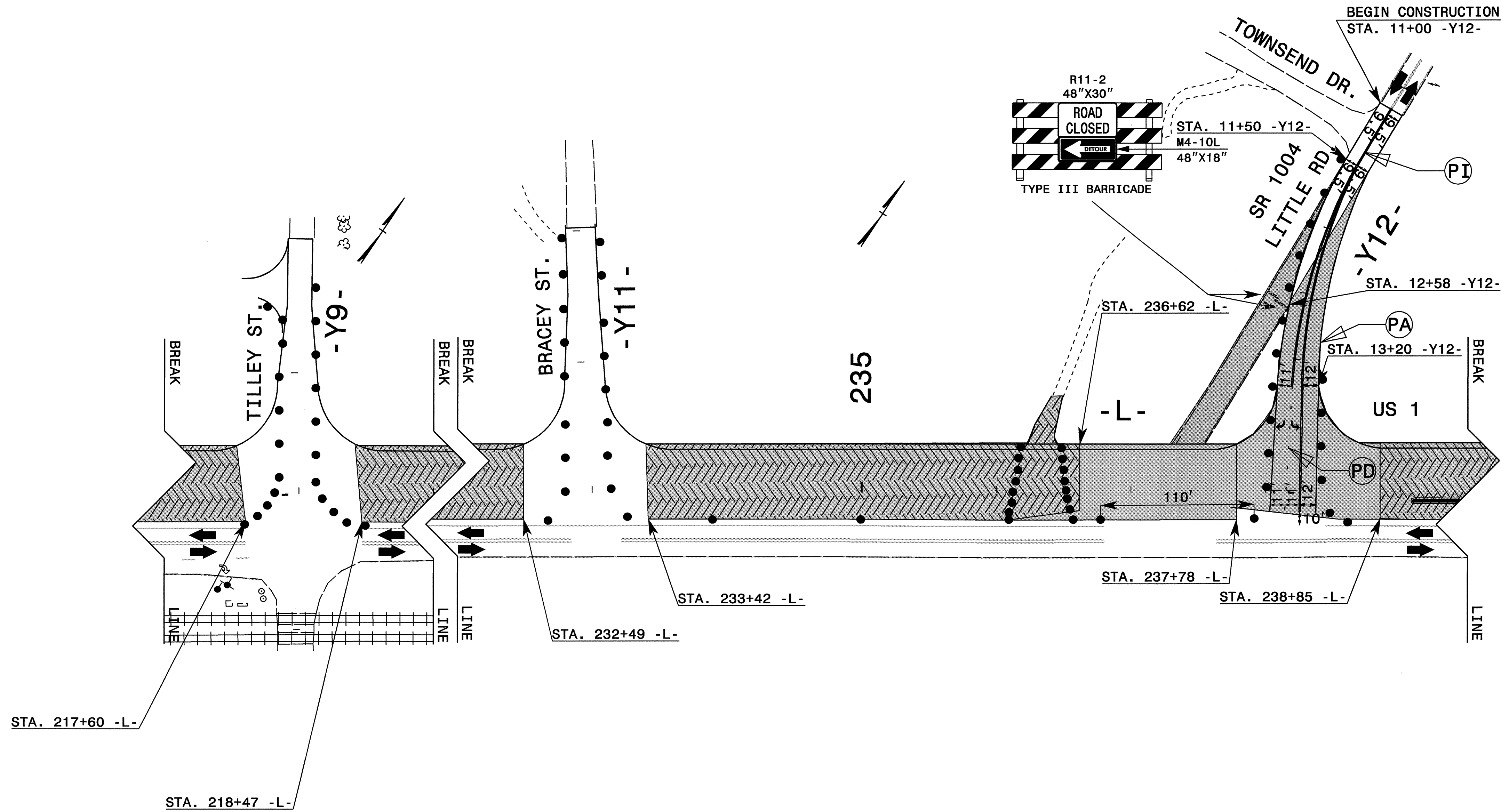

- : PROPOSED PAVEMENT MARKING LINE
- - - : EXISTING PAVEMENT MARKING LINE
- ↔ : QA ↔ : QD ↔ : QG
- ↔ : QB ↔ : QE
- ↔ : QC ↔ : QF
- ↔ : EXISTING PAVEMENT MARKING SYMBOL
- ▨ : PAVEMENT REMOVAL
- ▨ : ON-GOING CONSTRUCTION

- FOR PAVEMENT MARKING SCHEDULE SEE SHEET TCP-4
- TEMPORARY RAISED PAVEMENT MARKERS SHALL BE PLACED IN ACCORDANCE WITH RSD 1250.05 AND 1251.01

APPROVED: _____ DATE: _____	PHASE II DETAIL	
	SCALE: NONE	
	DATE: 02/08	
	DESIGN BY: DAH	
	REVIEWED BY: JWW	
		REVISIONS

19-FEB-2008 09:40
 \\dot\dfs\oof\Proj\IP\Projects-R\2502A\TrafficControl\Tcp\Phase II\R-2502A_TC_TCP_Phil_25.dgn
 ahays AT WZTC224241

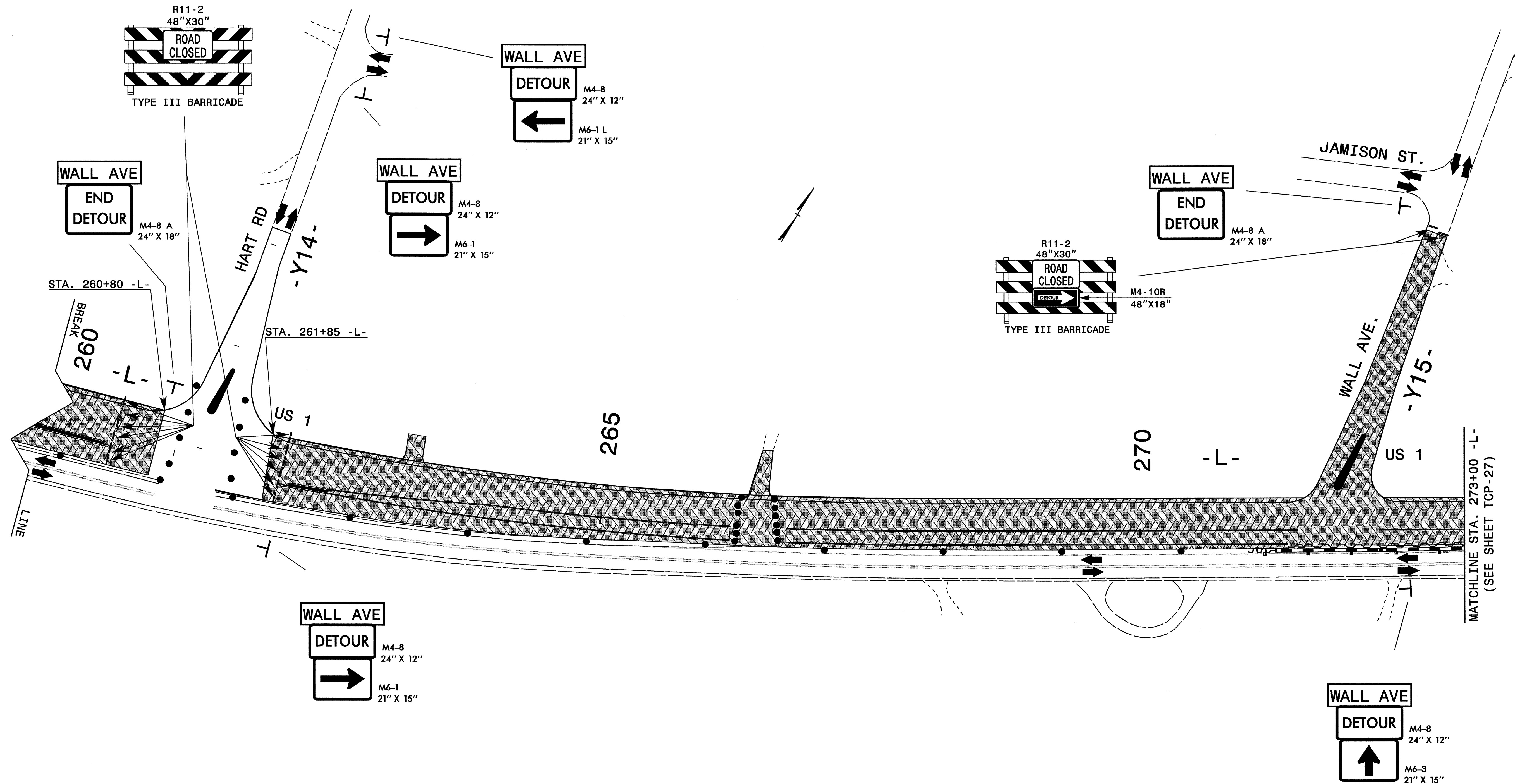

- : PROPOSED PAVEMENT MARKING LINE
- : EXISTING PAVEMENT MARKING LINE
- ↪ : QA ↻ : QD ↻ : QG
- ↪ : QB ↻ : QE
- ↪ : QC ↻ : QF
- ↪ : EXISTING PAVEMENT MARKING SYMBOL

- FOR PAVEMENT MARKING SCHEDULE SEE SHEET TCP-4
- TEMPORARY RAISED PAVEMENT MARKERS SHALL BE PLACED IN ACCORDANCE WITH RSD 1250.05 AND 1251.01

APPROVED: _____ DATE: _____	PHASE II DETAIL	
	SCALE: NONE	
	DATE: 02/08	
	DWG. BY: DAH	
	DESIGN BY: DAH	
REVIEWED BY: JWW	REVISIONS	

I9-FEB-2008 09:40 \\dot\dfsroot\Pro\TIP\Projects-R\2502A\TrafficControl\Top\Phase II\R-2502A-TC-TCP_Phil_26.dgn
 AT WZTC22424

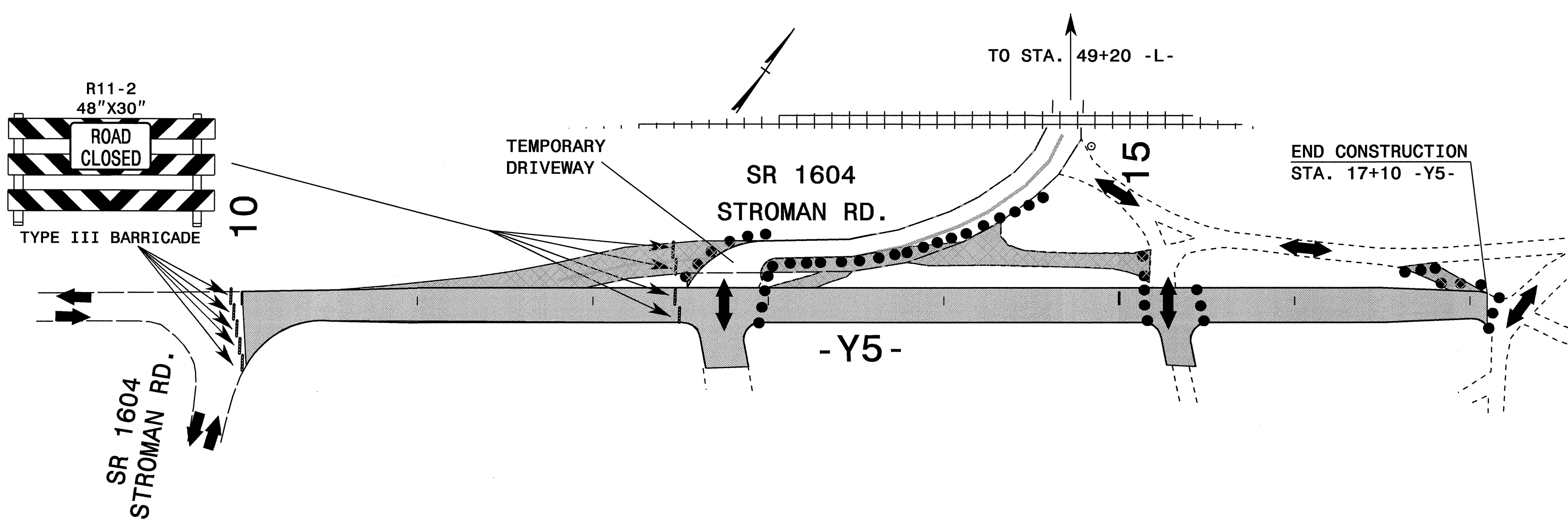
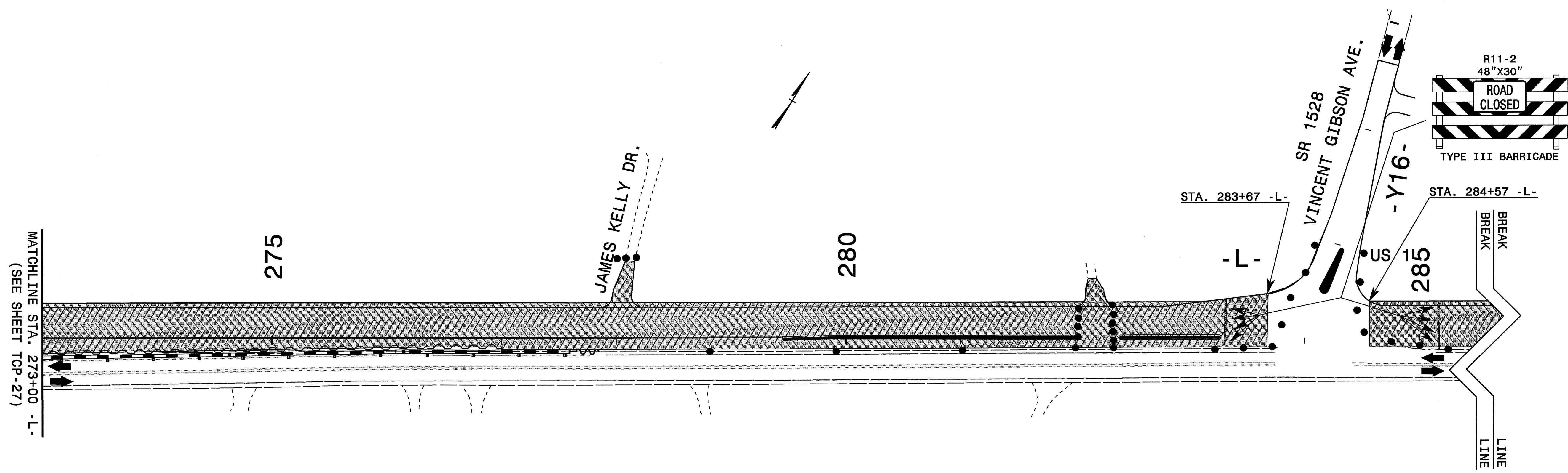

- : PROPOSED PAVEMENT MARKING LINE
- : EXISTING PAVEMENT MARKING LINE
- ↔ : QA ↔ : QD ↔ : QG
- ↔ : QB ↔ : QE
- ↔ : QC ↔ : QF
- ↔ : EXISTING PAVEMENT MARKING SYMBOL

ON-GOING CONSTRUCTION

- FOR PAVEMENT MARKING SCHEDULE SEE SHEET TCP-4
- TEMPORARY RAISED PAVEMENT MARKERS SHALL BE PLACED IN ACCORDANCE WITH RSD 1250.05 AND 1251.01

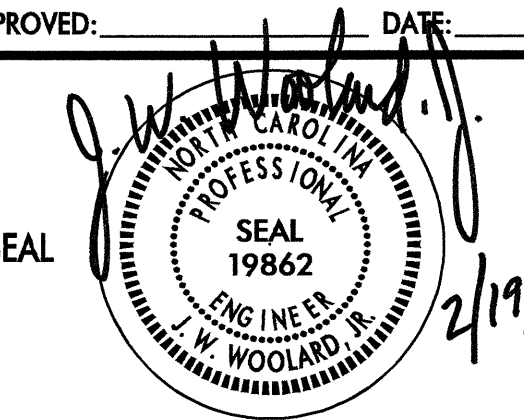
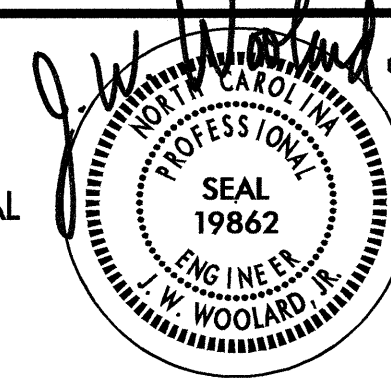
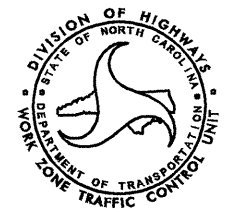
APPROVED: 	DATE: 2/19/08	PHASE II DETAIL	
SEAL 			
SCALE: NONE	DATE: 02/08		
DWG. BY: DAH	DESIGN BY: DAH		
REVIEWED BY: JWW			
		REVISIONS	

19-FEB-2008 09:39
 \\dot\dfsroot\01\Pro\TIP\Projects-R\2502A\TrafficControl\top\Phase II\NR-2502A_Tc_TCP_Phil_27.dgn
 ahayes AT WZTC22424

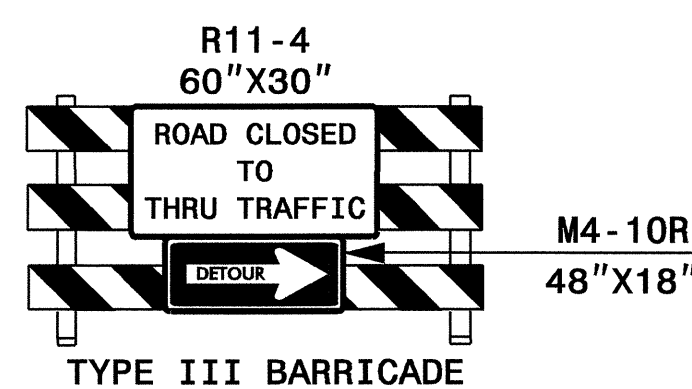
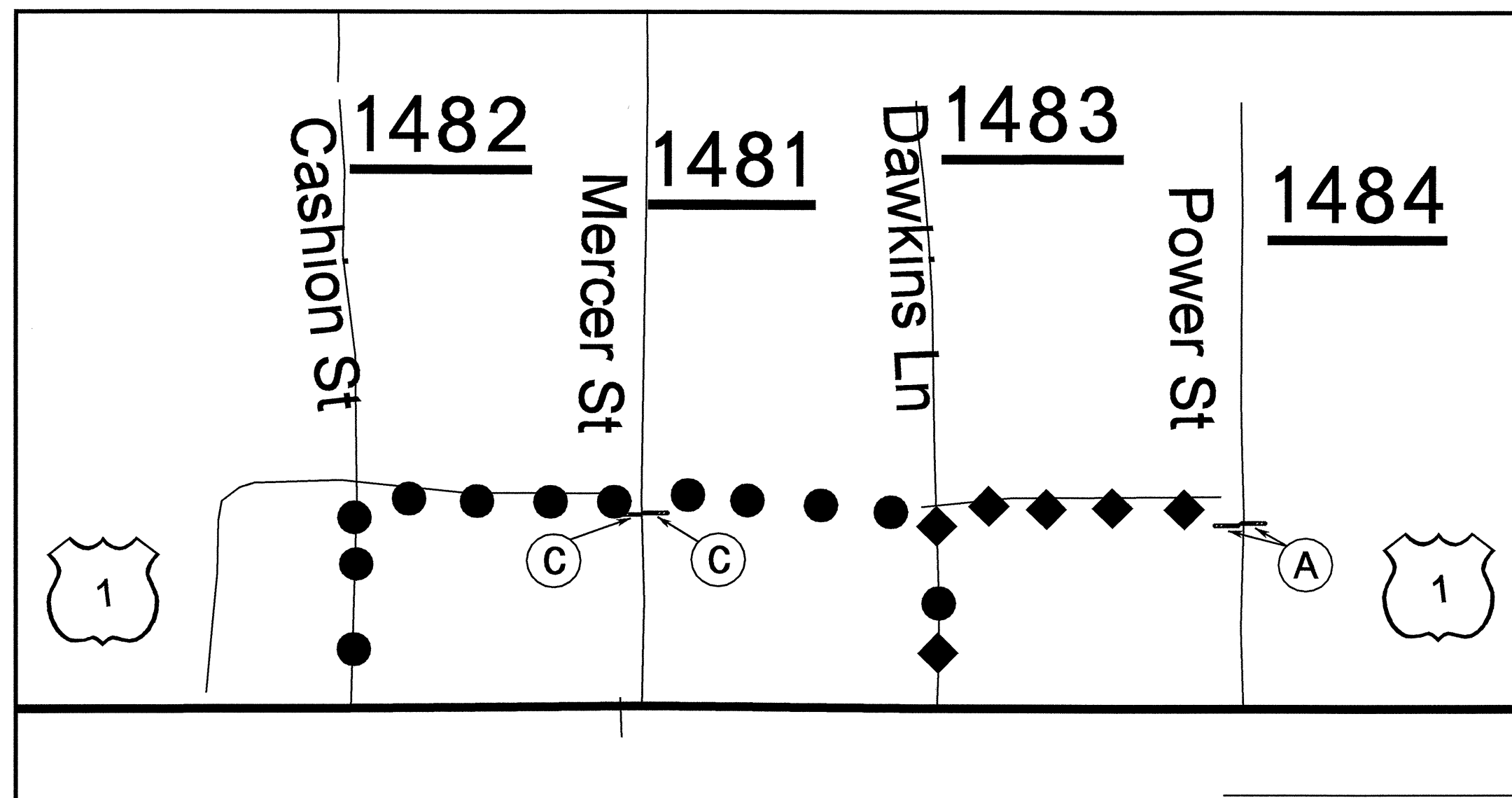

(A)

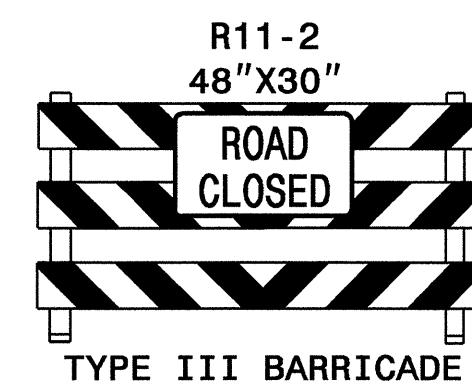

(B)

● MERCER ST. DETOUR

◆ POWER ST. DETOUR

SIGN NUMBER: SP07209
 TYPE: D
 QUANTITY: 1
 SIGN WIDTH: 48"
 HEIGHT: 14"
 TOTAL AREA: 4.7 Sq.Ft.
 BORDER TYPE: RECESSED
 RECESS: 0.38"
 WIDTH: 0.63"
 RADII: 1.5"
 NO. Z BARS: LENGTH:

BACKG COLOR: Fluorescent Orange
 COPY COLOR: Black

SYMBOL	X	Y	WID	HT

MAT'L: 0.125" (3.2 mm) ALUMINUM
 0.079" COMPOSITE

DESIGN BY: R. HENNEIN
 PROJECT ID: N/A
 CHECKED BY: DIV: N/A
 DATE: Jul 09, 2007

USE NOTES:
 1. Legend and border shall be direct applied non-reflective sheeting.
 2. Background shall be Type VII, VIII, or IX (prismatic) retroreflective sheeting.

BORDER
 R=1.5"
 TH=0.63"
 IN=0.38"

Spacing Factor is 1 unless specified otherwise

LETTER POSITIONS

Letter spacings are to start of next letter												Series/Size
	M	E	R	C	E	R	S	T				C 2000
	4.7	5.3	4.1	4.3	4.6	4.1	3.4	6	3.9	3.1	4.7	38.6

SIGN NUMBER: SP07210
 TYPE: D
 QUANTITY: 1
 SIGN WIDTH: 48"
 HEIGHT: 14"
 TOTAL AREA: 4.7 Sq.Ft.
 BORDER TYPE: RECESSED
 RECESS: 0.38"
 WIDTH: 0.63"
 RADII: 1.5"
 NO. Z BARS: LENGTH:

BACKG COLOR: Fluorescent Orange
 COPY COLOR: Black

SYMBOL	X	Y	WID	HT

MAT'L: 0.125" (3.2 mm) ALUMINUM
 0.079" COMPOSITE

DESIGN BY: R. HENNEIN
 PROJECT ID: N/A
 CHECKED BY: DIV: N/A
 DATE: Jul 09, 2007

USE NOTES:
 1. Legend and border shall be direct applied non-reflective sheeting.
 2. Background shall be Type VII, VIII, or IX (prismatic) retroreflective sheeting.

BORDER
 R=1.5"
 TH=0.63"
 IN=0.38"

Spacing Factor is 1 unless specified otherwise

LETTER POSITIONS

Letter spacings are to start of next letter												Series/Size
	P	O	W	E	R	S	S	T				C 2000
	4.7	4.4	4.3	5.4	4.1	4.1	3.4	6	3.9	3.1	4.7	38.6

FILENAME: SP07209_gomessst

NORTH CAROLINA D.O.T. SIGN DETAIL

NOTE: SEE TCP-18, 19, AND 26 FOR OFFSITE DETOUR SIGNING.

APPROVED: _____ DATE: _____	PHASE II DETAIL	
	SCALE: NONE	REVISIONS
	DATE: 02/08	
	DWG. BY: DAH	
	DESIGN BY: DAH	
REVIEWED BY: JWW		

19-FEB-2008 11:37
 \\dot\dfs\root\Proj\TIP\Projects-R\2502A\TrafficControl\Top\Phase II\R-2502A_TC_TCP_Phil_28_05D.dgn
 at WZTC224241

TRAFFIC CONTROL TREATMENT FOR NEW STOP LOCATION FOR HIGH VOLUME ROAD

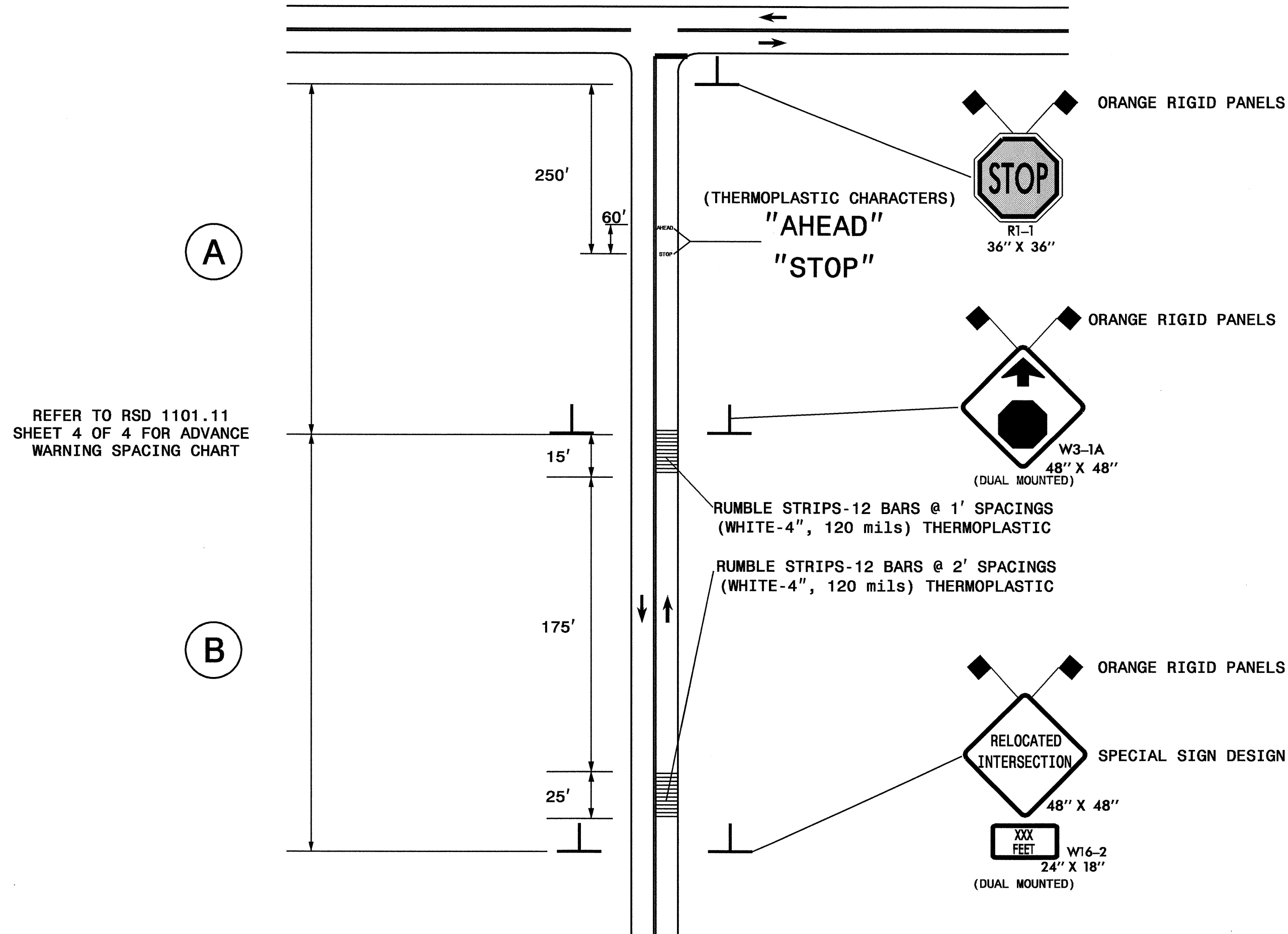

TRAFFIC CONTROL TREATMENT FOR NEW STOP LOCATION FOR MEDIUM TO HIGH VOLUME ROAD

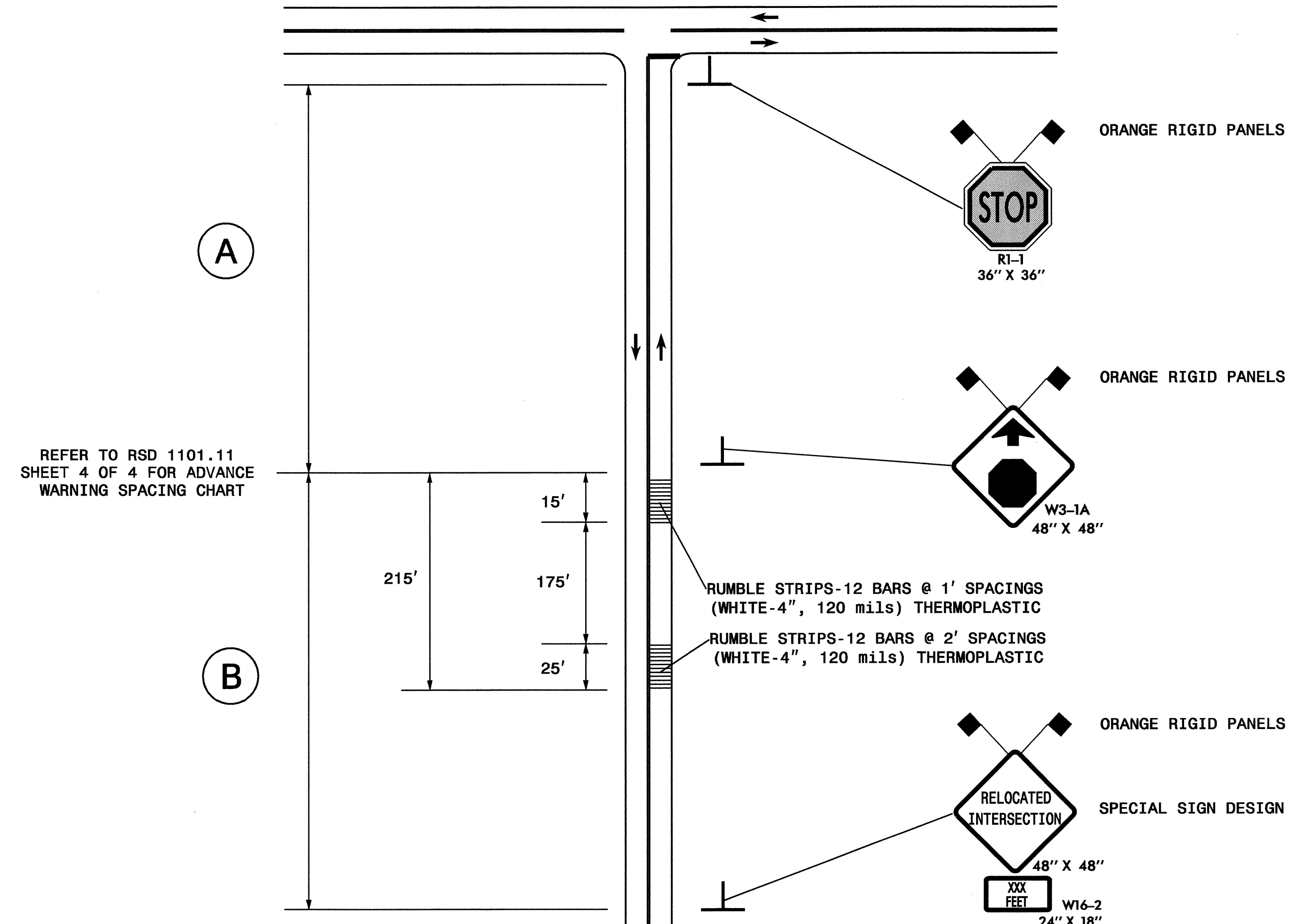

TRAFFIC CONTROL TREATMENT FOR NEW STOP LOCATION FOR MEDIUM VOLUME ROAD

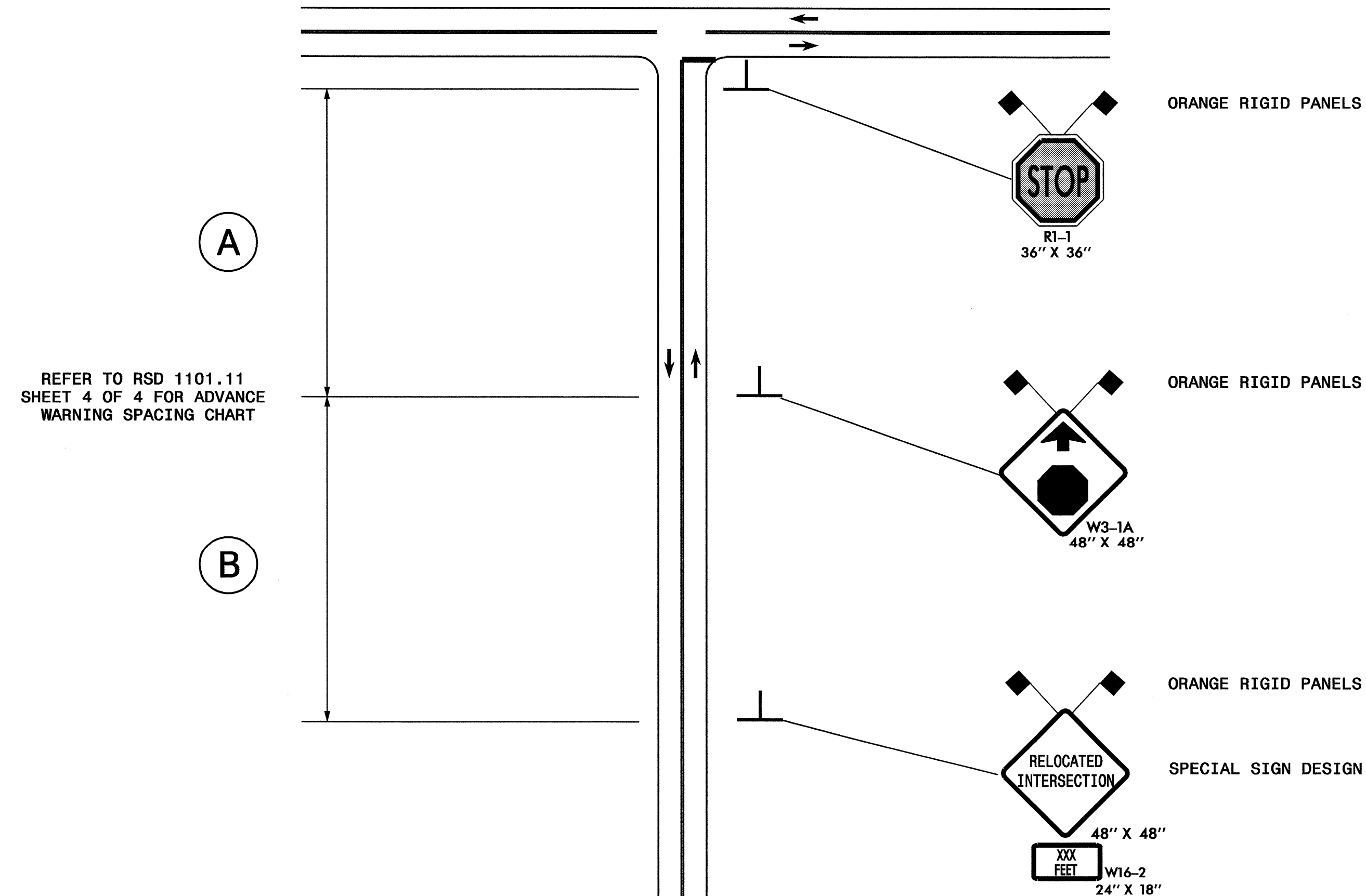

TRAFFIC CONTROL TREATMENT FOR NEW STOP LOCATION FOR LOW VOLUME ROAD

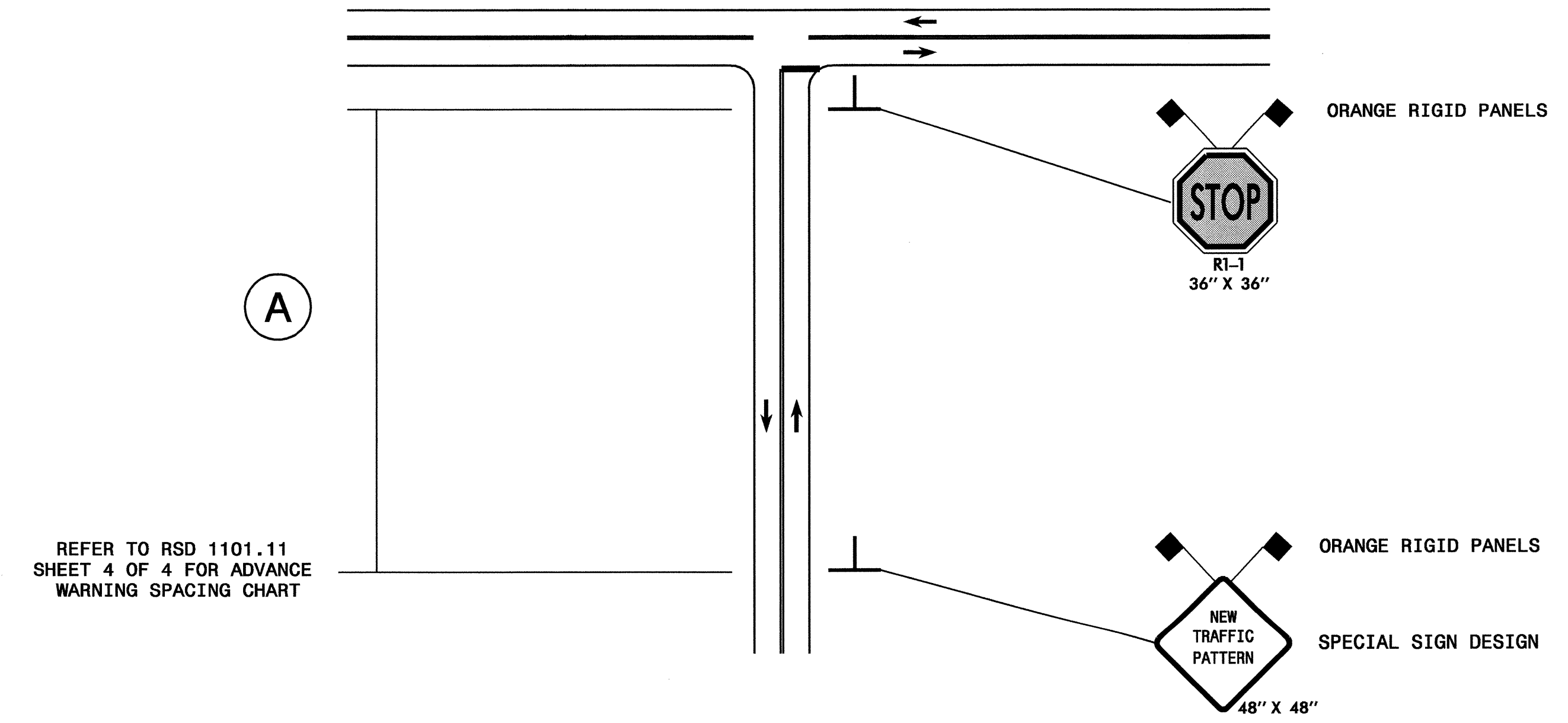

NOTE: MAY ADD CHANGEABLE MESSAGE SIGN IN ADVANCE OF "NEW TRAFFIC PATTERN" SIGN FOR ADDITIONAL ADVANCE WARNING.

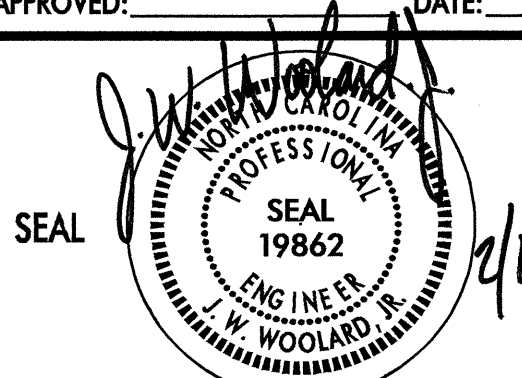
APPROVED: 	DATE: 2/19/08	<p>TRAFFIC CONTROL FOR NEW STOP LOCATIONS FOR -Y- LINES</p>							
SCALE: NONE	DATE: 5/07								
DESIGN BY: DAH	REVIEWED BY: JWW	<table border="1"> <tr> <th colspan="2">REVISIONS</th> </tr> <tr> <td> </td> <td> </td> </tr> <tr> <td> </td> <td> </td> </tr> </table>		REVISIONS					
REVISIONS									

I9-FEB-2008 10:01 \\dot\dfsroot\proj\TIP\Projects-R\2502A\TrafficControl\Top\Phase II\R-2502A-TC-TCP-PHIL-28A-Rumble.dgn AT WZTC22424

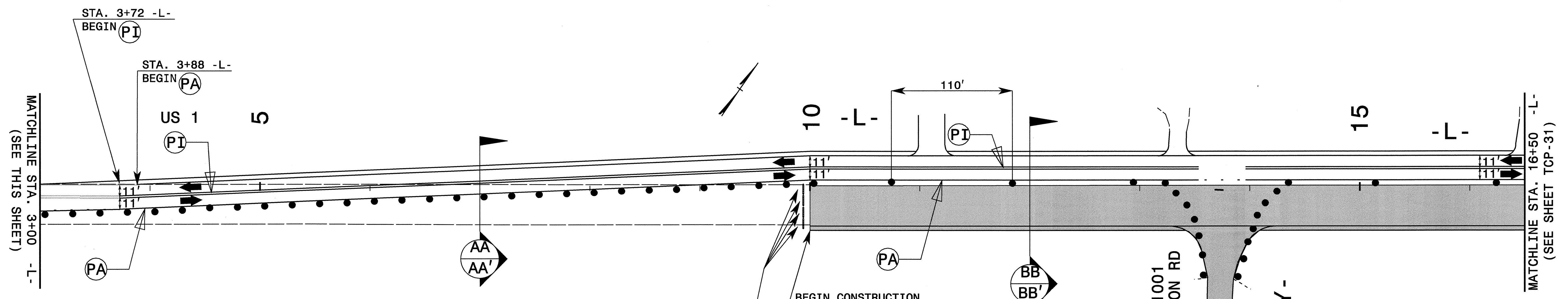
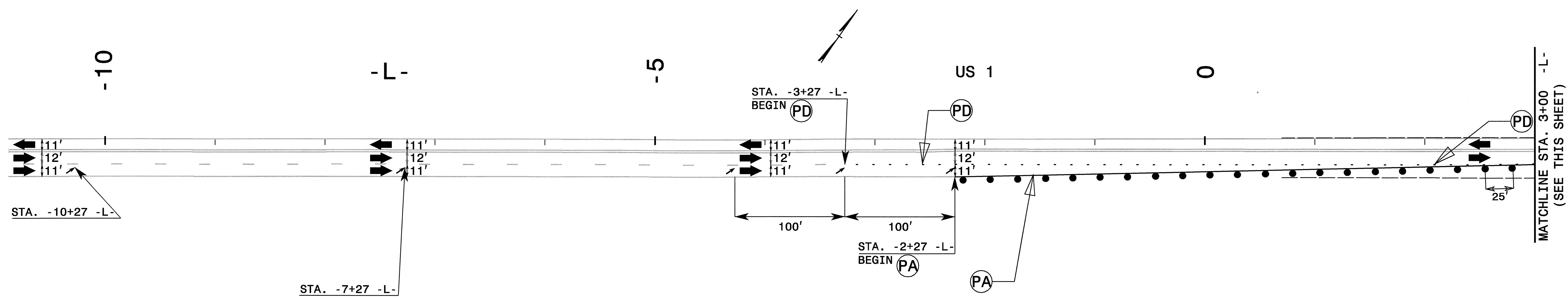

- : PROPOSED PAVEMENT MARKING LINE
- - - : EXISTING PAVEMENT MARKING LINE
- ↔ : QA ↔ : QD ↔ : QG
- ↔ : QB ↔ : QE
- ↔ : QC ↔ : QF
- ↔ : EXISTING PAVEMENT MARKING SYMBOL

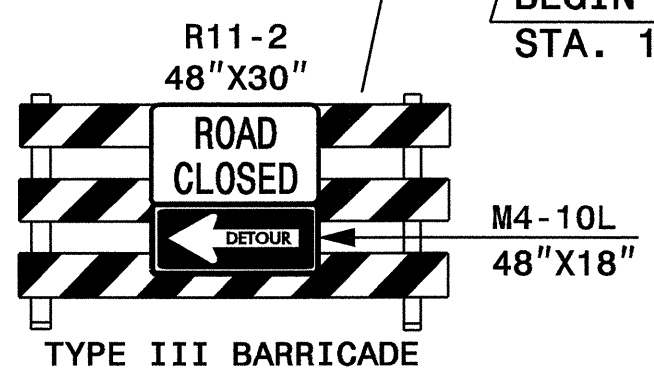

FOR SECTIONAL VIEWS A-A' AND B-B' SEE SHEET TCP-30.

- FOR PAVEMENT MARKING SCHEDULE SEE SHEET TCP-4
- TEMPORARY RAISED PAVEMENT MARKERS SHALL BE PLACED IN ACCORDANCE WITH RSD 1250.05 AND 1251.01

APPROVED:	DATE: 2/19/08	PHASE III DETAIL	
SEAL			
SCALE: NONE		REVISIONS	
DATE: 02/08		DESIGN BY: DAH	
DWG. BY: DAH		REVIEWED BY: JWW	
CADD FILE			

19-FEB-2008 09:37
 \\dot\dfs\0010\Proj\TIP\Projects-R\2502A\TrafficControl\Top\Phase III\N-R-2502A_TC_TCP_Phill.L29.dgn
 ahayes AT WZTC24241

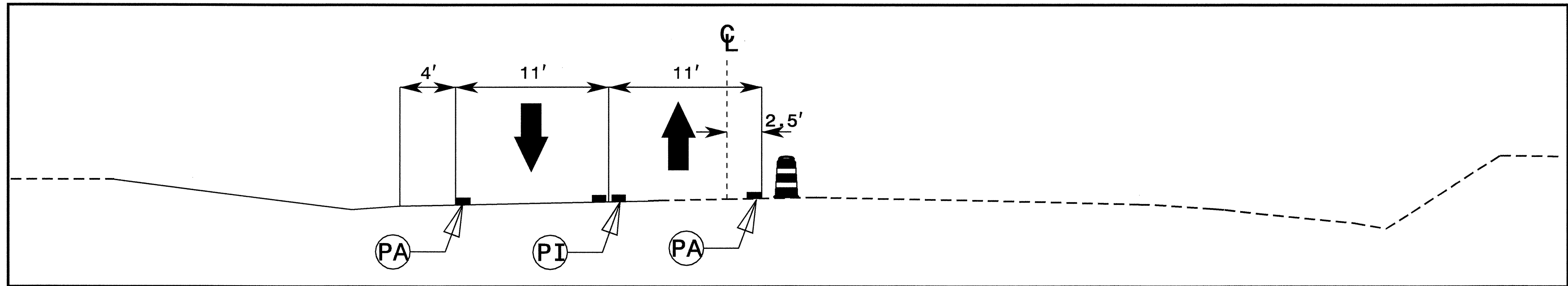

CUT SECTION AA
STA. 7+00 -L- AA'

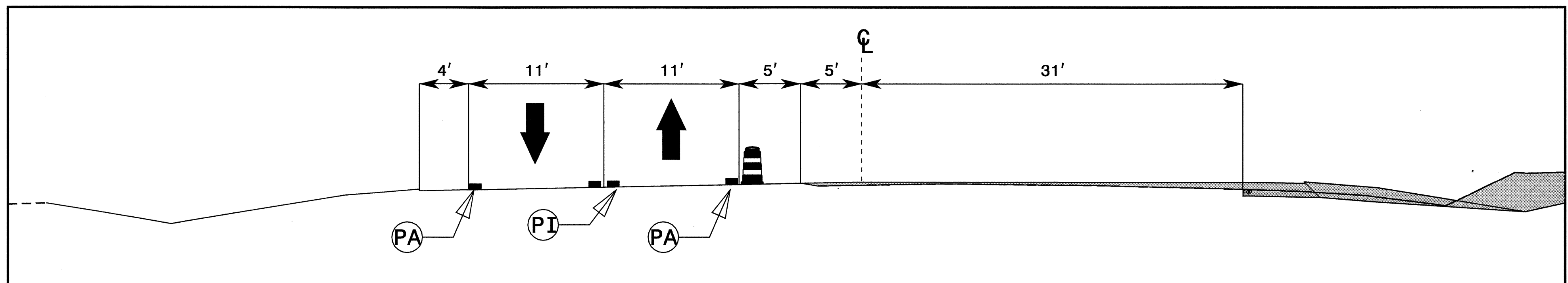

CUT SECTION BB
STA. 12+00 -L- BB'

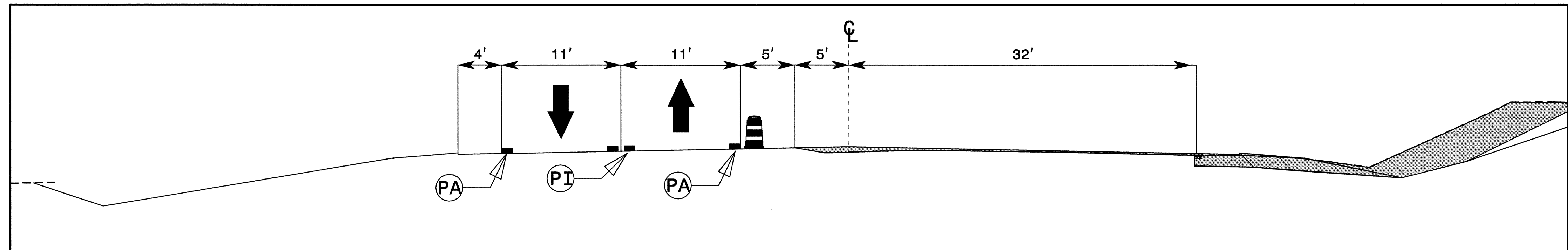

CUT SECTION CC
STA. 31+50 -L- CC'

19-FEB-2008 09:37
 \\dot\dfs\cot0\Proj\Projects-R\2502A\Traffic\TrafficControl\Tcp\Phase III\NR-2502A.TC.TCP_Phill_30_CS_AA-CC.dgn
 ahays AT WZTC22424

APPROVED:	DATE:	PHASE III DETAIL							
	2/19/08								
SCALE: NONE	DATE: 02/08								
DWG. BY: DAH	DESIGN BY: DAH								
REVIEWED BY: JWW									
		REVISIONS							
		<table border="1"> <tr><td> </td><td> </td></tr> <tr><td> </td><td> </td></tr> <tr><td> </td><td> </td></tr> </table>							
		CADD FREE							

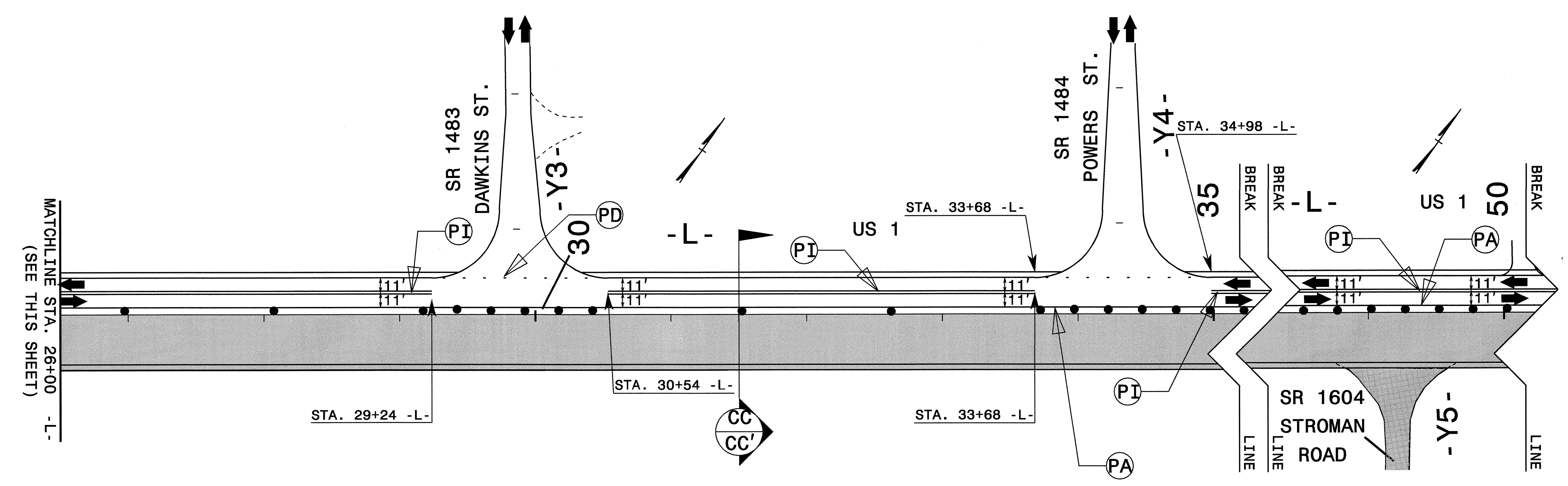
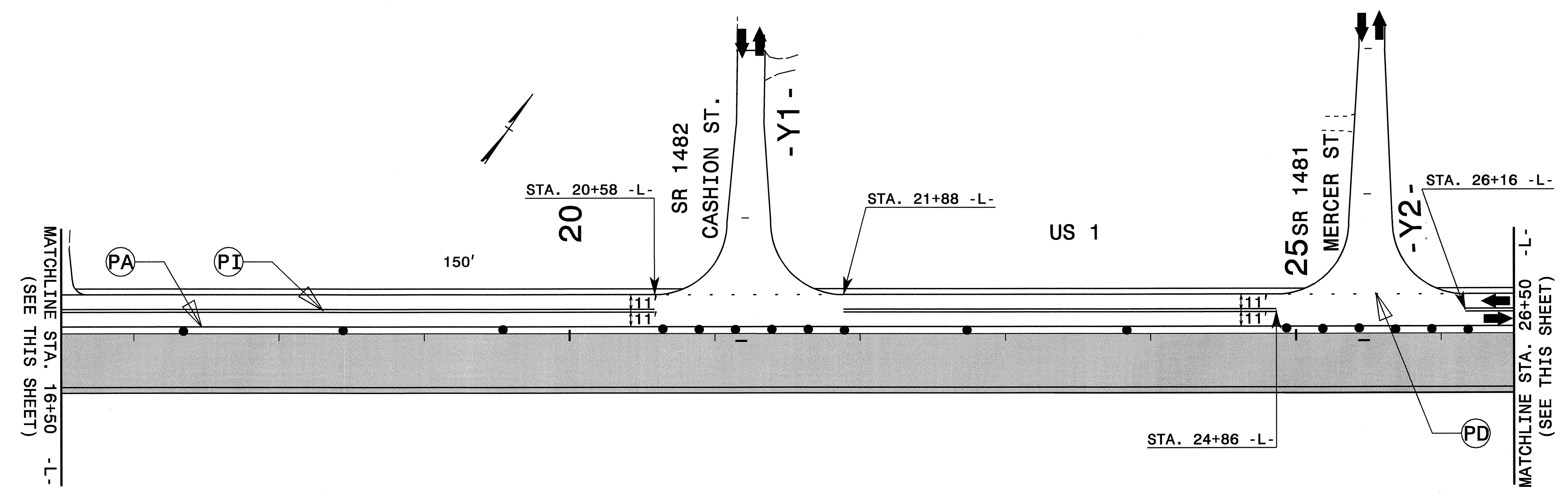

- : PROPOSED PAVEMENT MARKING LINE
- - - : EXISTING PAVEMENT MARKING LINE
- ↗ : QA ↖ : QD ↕ : QG
- ↘ : QB ↗ : QE
- ↑ : QC ↓ : QF
- ↻ : EXISTING PAVEMENT MARKING SYMBOL

FOR SECTIONAL VIEW C-C' SEE SHEET TCP-30.

- FOR PAVEMENT MARKING SCHEDULE SEE SHEET TCP-4
- TEMPORARY RAISED PAVEMENT MARKERS SHALL BE PLACED IN ACCORDANCE WITH RSD 1250.05 AND 1251.01

APPROVED: _____ DATE: _____

SEAL

2/19/08

PHASE III DETAIL

SCALE: NONE		REVISIONS
DATE: 02/08		
DWG. BY: DAH		
DESIGN BY: DAH		
REVIEWED BY: JWW		

19-FEB-2008 09:36
 \\dot\dfsroot\ProJ\TIP\Projects-R\2502A\TrafficControl\Top\Phase III\R-2502A.TC.TCP_Phill_31.dgn
 AT WZTC224241

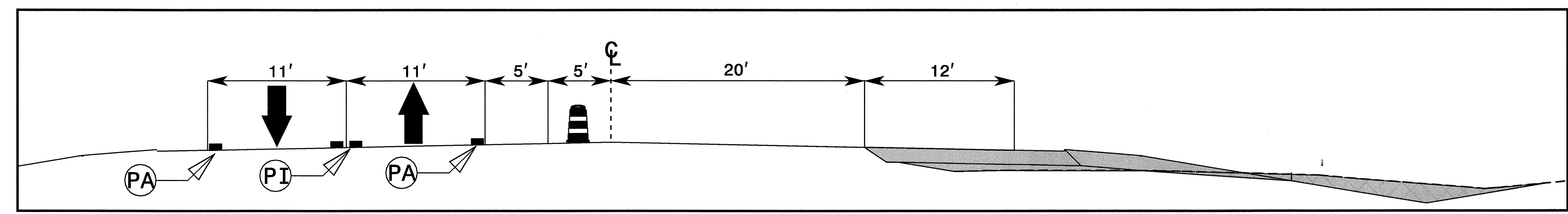
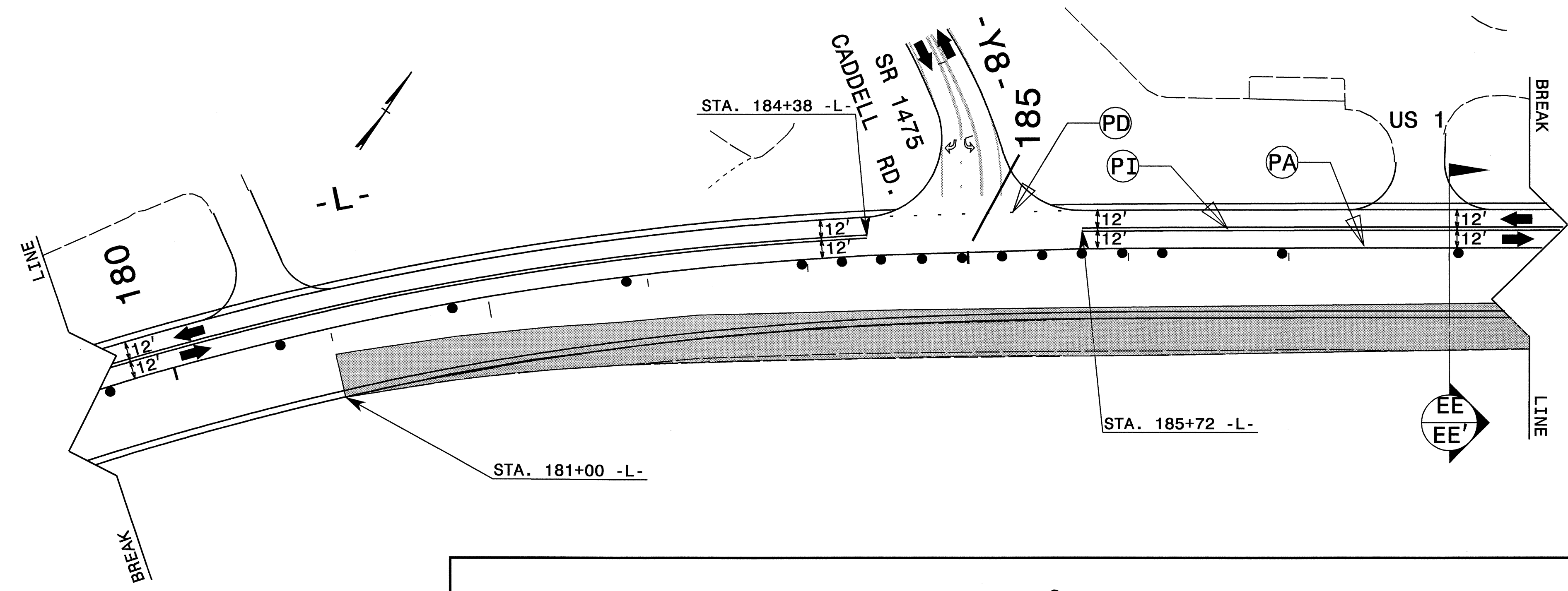

CUT SECTION
STA. 188+00 -L- EE
EE'

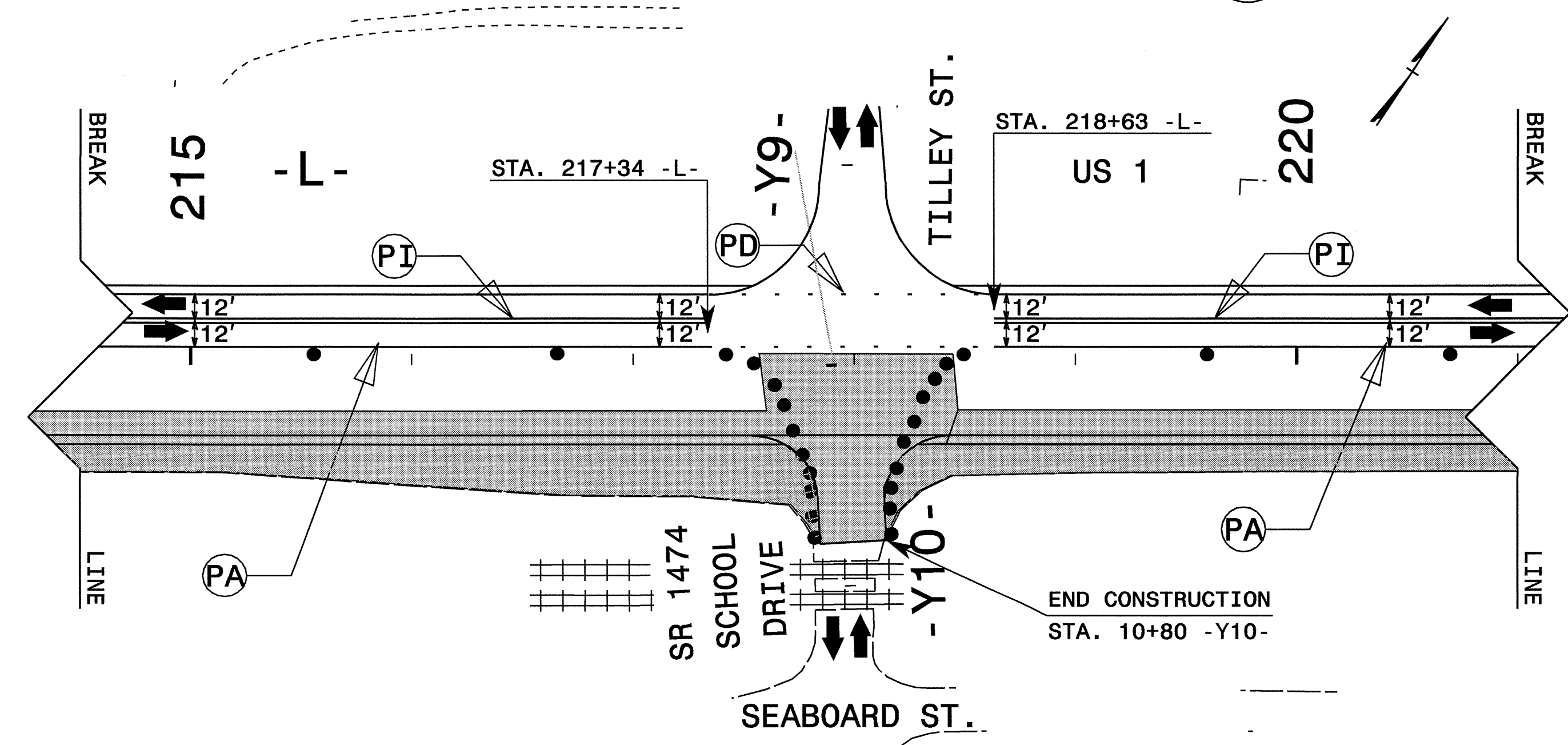

- : PROPOSED PAVEMENT MARKING LINE
- : EXISTING PAVEMENT MARKING LINE
- ↪ : QA ↪ : QD ↪ : QG
- ↪ : QB ↪ : QE
- ↪ : QC ↪ : QF
- ↪ : EXISTING PAVEMENT MARKING SYMBOL

- FOR PAVEMENT MARKING SCHEDULE SEE SHEET TCP-4
- TEMPORARY RAISED PAVEMENT MARKERS SHALL BE PLACED IN ACCORDANCE WITH RSD 1250.05 AND 1251.01

APPROVED: _____ DATE: _____	PHASE III DETAIL									
SCALE: NONE	DATE: 02/08	<table border="1"> <thead> <tr> <th colspan="2">REVISIONS</th> </tr> </thead> <tbody> <tr><td> </td><td> </td></tr> <tr><td> </td><td> </td></tr> <tr><td> </td><td> </td></tr> </tbody> </table>	REVISIONS							
REVISIONS										
DWG. BY: DAH	DESIGN BY: DAH									
REVIEWED BY: JWW	CADD FILE									

19-FEB-2008 09:36
 \\dot\dfs\root\Pro\TIP\Projects-R\2502A\TrafficControl\Top\Phase III\NR-2502A.TC.TCP_Phill_33.dgn
 ghayes AT WZTC224241

- : PROPOSED PAVEMENT MARKING LINE
- : EXISTING PAVEMENT MARKING LINE
- ↪ : QA ↪ : QD ↪ : QG
- ↪ : QB ↪ : QE
- ↪ : QC ↪ : QF
- ↪ : EXISTING PAVEMENT MARKING SYMBOL

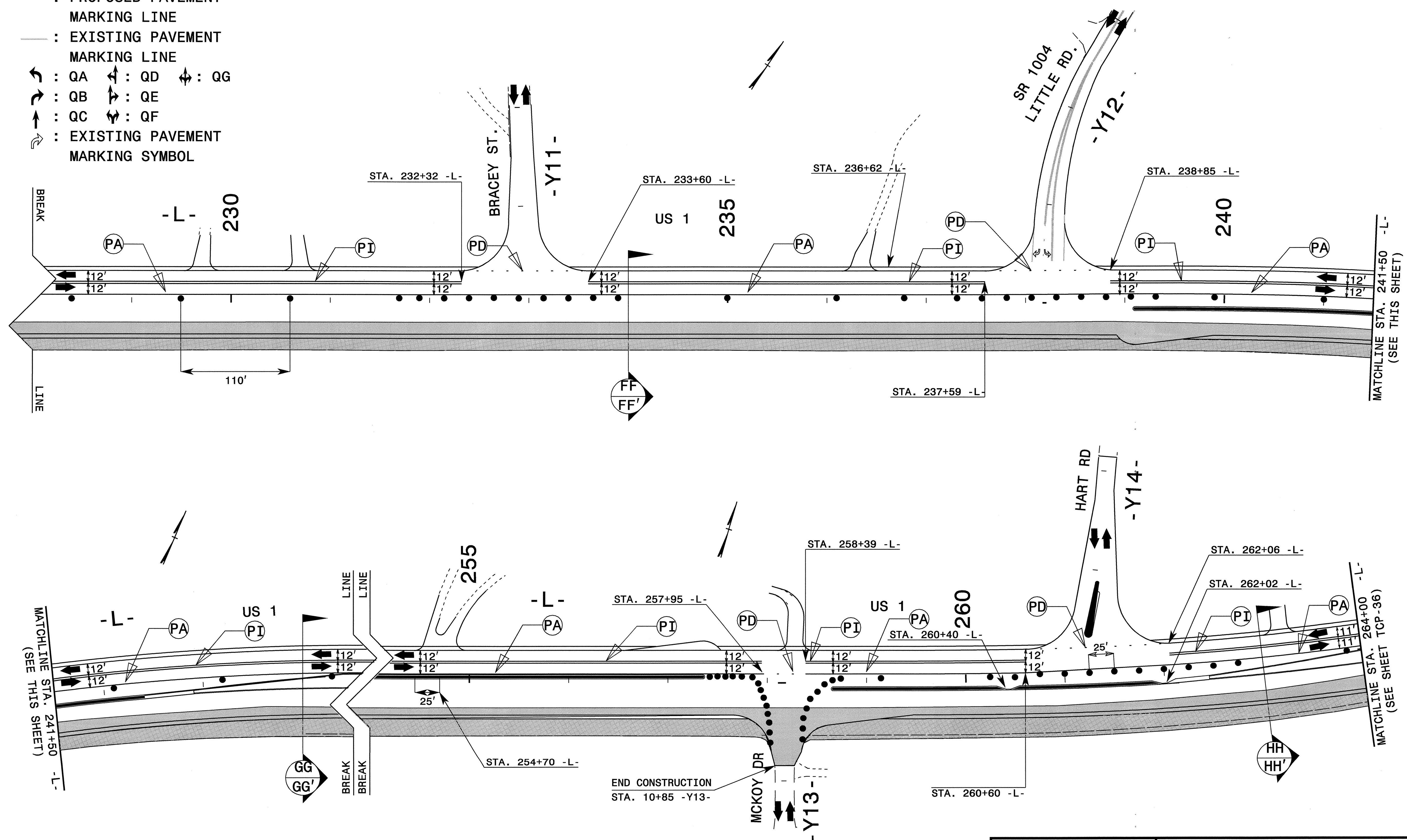

FOR SECTIONAL VIEWS FF-FF', GG-GG', AND HH-HH' SEE SHEET TCP-35.

- FOR PAVEMENT MARKING SCHEDULE SEE SHEET TCP-4
- TEMPORARY RAISED PAVEMENT MARKERS SHALL BE PLACED IN ACCORDANCE WITH RSD 1250.05 AND 1251.01

APPROVED: _____ DATE: _____	PHASE III DETAIL	
SCALE: NONE	REVISIONS	
DATE: 02/08		
DESIGN BY: DAH		
REVIEWED BY: JWW		

19-FEB-2008 09:35
 \\dot\dfsroot\01\Proj\IP\Projects-R\R2502A\TrafficControl\Top\Phase III\R-2502A_TC_TCP_PIII_34.dgn
 ahaves AT WZTC22424

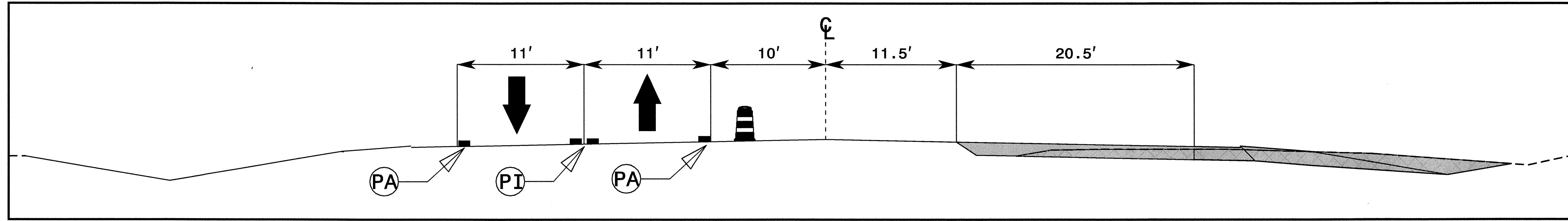

CUT SECTION **FF**
STA. 234+00 -L- **FF'**

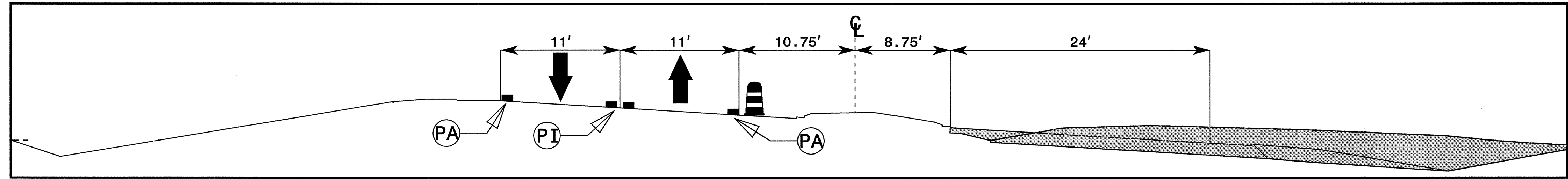

CUT SECTION **GG**
STA. 244+00 -L- **GG'**

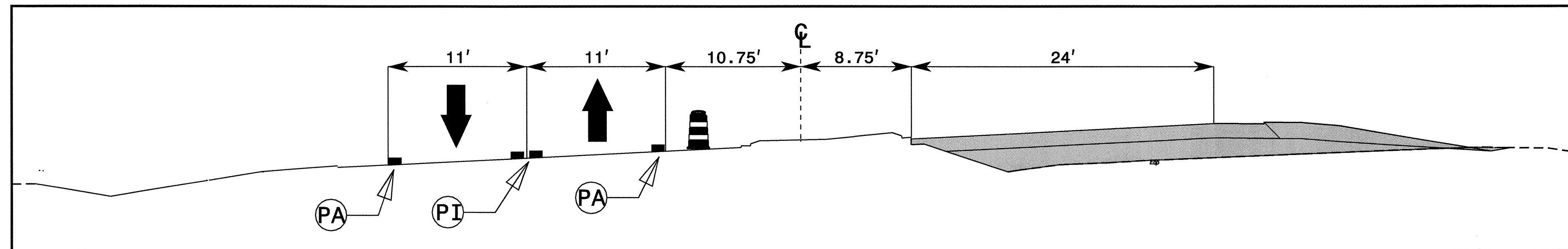

CUT SECTION **HH**
STA. 263+00 -L- **HH'**

19-FEB-2008 10:53
 \\dot\dfsroot\proj\ipproj\projects-r\2502a\TrafficControl\Phase III\R-2502A_Tc_TCP_PIII_35_CS_FF-HH.dgn
 ahaves AT WZTC22424

APPROVED: _____ DATE: _____		PHASE III DETAIL	
SCALE: NONE	DATE: 02/08		REVISIONS
DESIGN BY: DAH	REVIEWED BY: JWW		

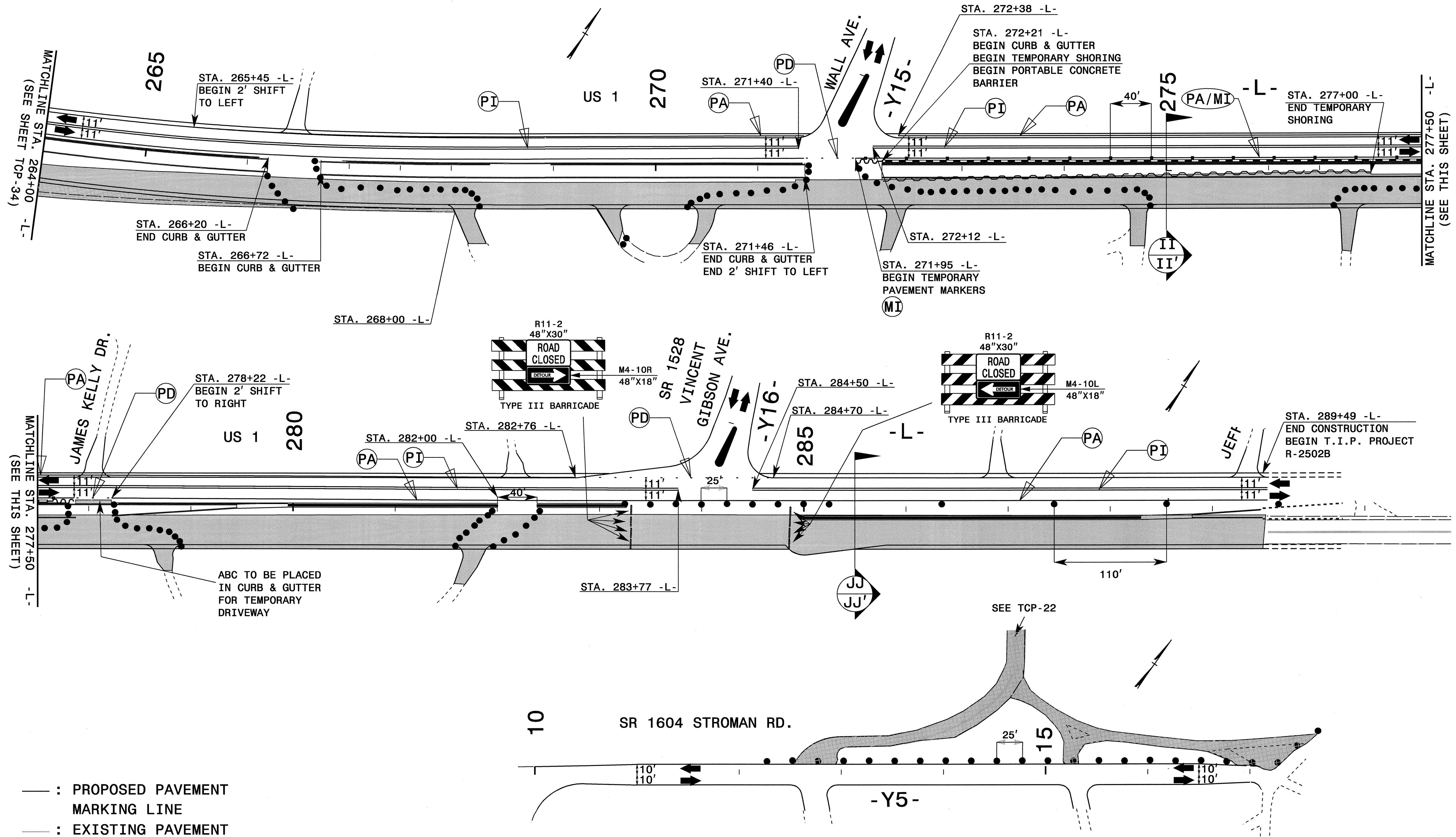

- : PROPOSED PAVEMENT MARKING LINE
- - - : EXISTING PAVEMENT MARKING LINE
- ↪ : QA ↪ : QD ↪ : QG
- ↪ : QB ↪ : QE
- ↪ : QC ↪ : QF
- ↪ : EXISTING PAVEMENT MARKING SYMBOL

FOR SECTIONAL VIEWS II-II' AND JJ-JJ' SEE SHEET TCP-37.

- FOR PAVEMENT MARKING SCHEDULE SEE SHEET TCP-4
- TEMPORARY RAISED PAVEMENT MARKERS SHALL BE PLACED IN ACCORDANCE WITH RSD 1250.05 AND 1251.01

APPROVED: _____ DATE: _____

SEAL

2/19/08

PHASE III DETAIL

SCALE: NONE		REVISIONS
DATE: 02/08		
DESIGN BY: DAH		
REVIEWED BY: JWW		

19-FEB-2008 09:34
 \\dot\dfs\root\proj\TIP\Projects-R\2502A\Traffic\TrafficControl\Top\Phase III\NR-2502A_TC_TCP_Phill_36.dgn
 AT WZTC22424

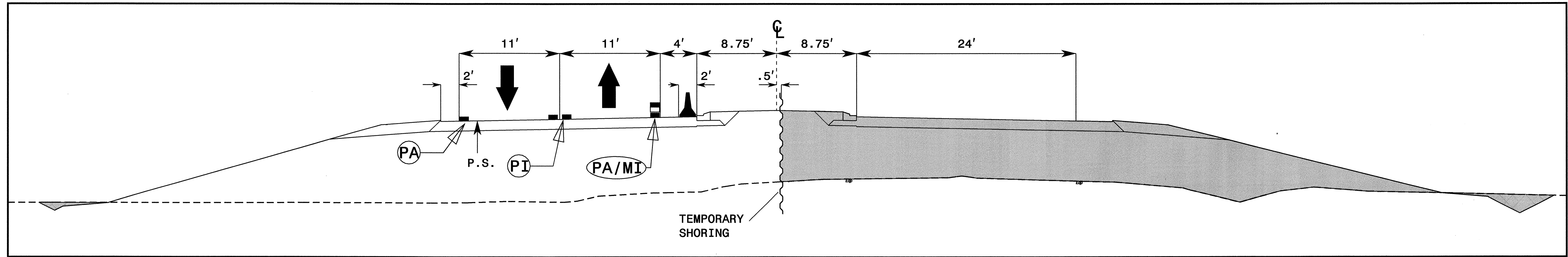

CUT SECTION **II**
 STA.275+00 -L- **II'**

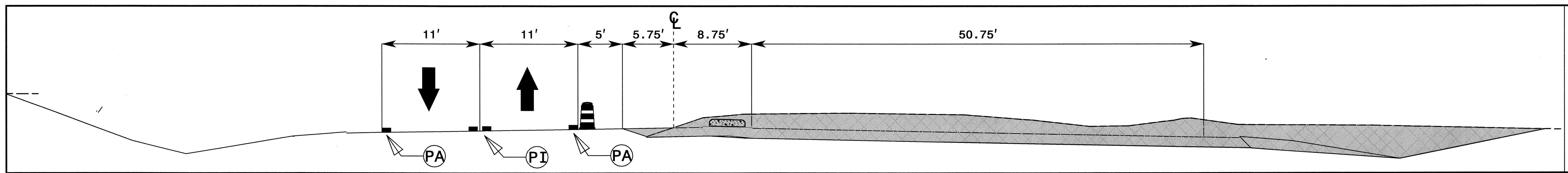

CUT SECTION **JJ**
 STA.285+50 -L- **JJ'**

19-FEB-2008 09:34
 \\dot\dfs\cot0\Pro\IP\Projects-R\2502A\TrafficControl\Top\Phase III\NR-2502A.TC.TCP_PIII_37_CS_II-JJ.dgn
 ahays AT WZTC22424

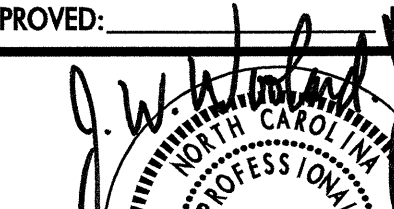
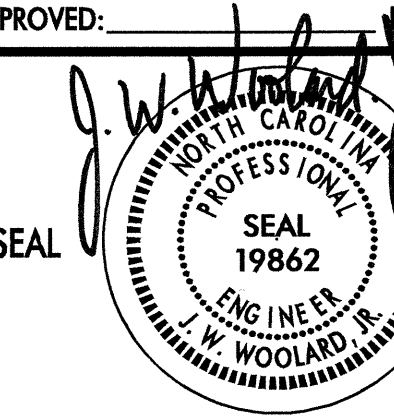
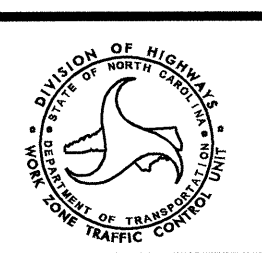
APPROVED: 	DATE: 2/19/08	PHASE III DETAIL									
SEAL 											
SCALE: NONE	DESIGN BY: DAH										
DATE: 02/08	REVIEWED BY: JWW										
DESIGN BY: DAH											
REVIEWED BY: JWW		<table border="1"> <thead> <tr> <th colspan="2">REVISIONS</th> </tr> </thead> <tbody> <tr> <td> </td> <td> </td> </tr> <tr> <td> </td> <td> </td> </tr> <tr> <td> </td> <td> </td> </tr> </tbody> </table>		REVISIONS							
REVISIONS											

TWO-WAY UNDIVIDED ** (US-1)

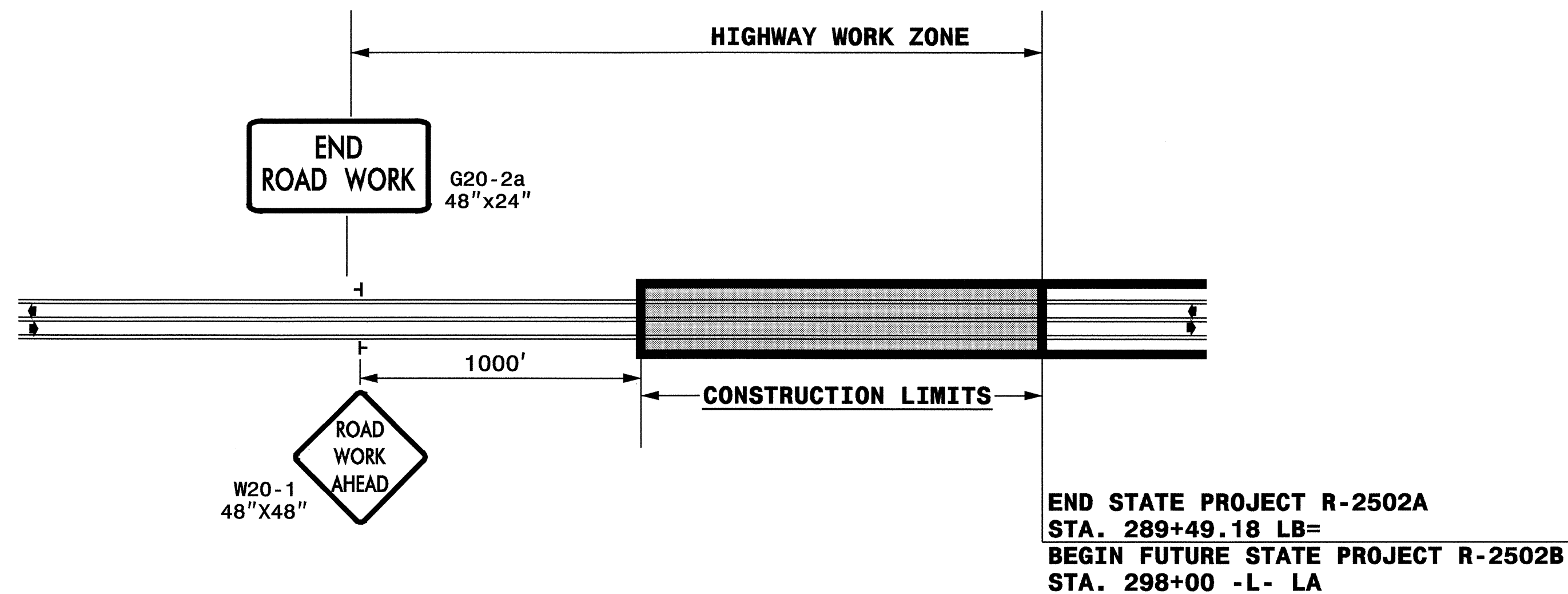

STATE OF NORTH CAROLINA
DEPT. OF TRANSPORTATION
DIVISION OF HIGHWAYS
RALEIGH, N.C.

ROADWAYS INTERSECTING ALONG 2 WAY UNDIVIDED WORK ZONE (Y-LINES)

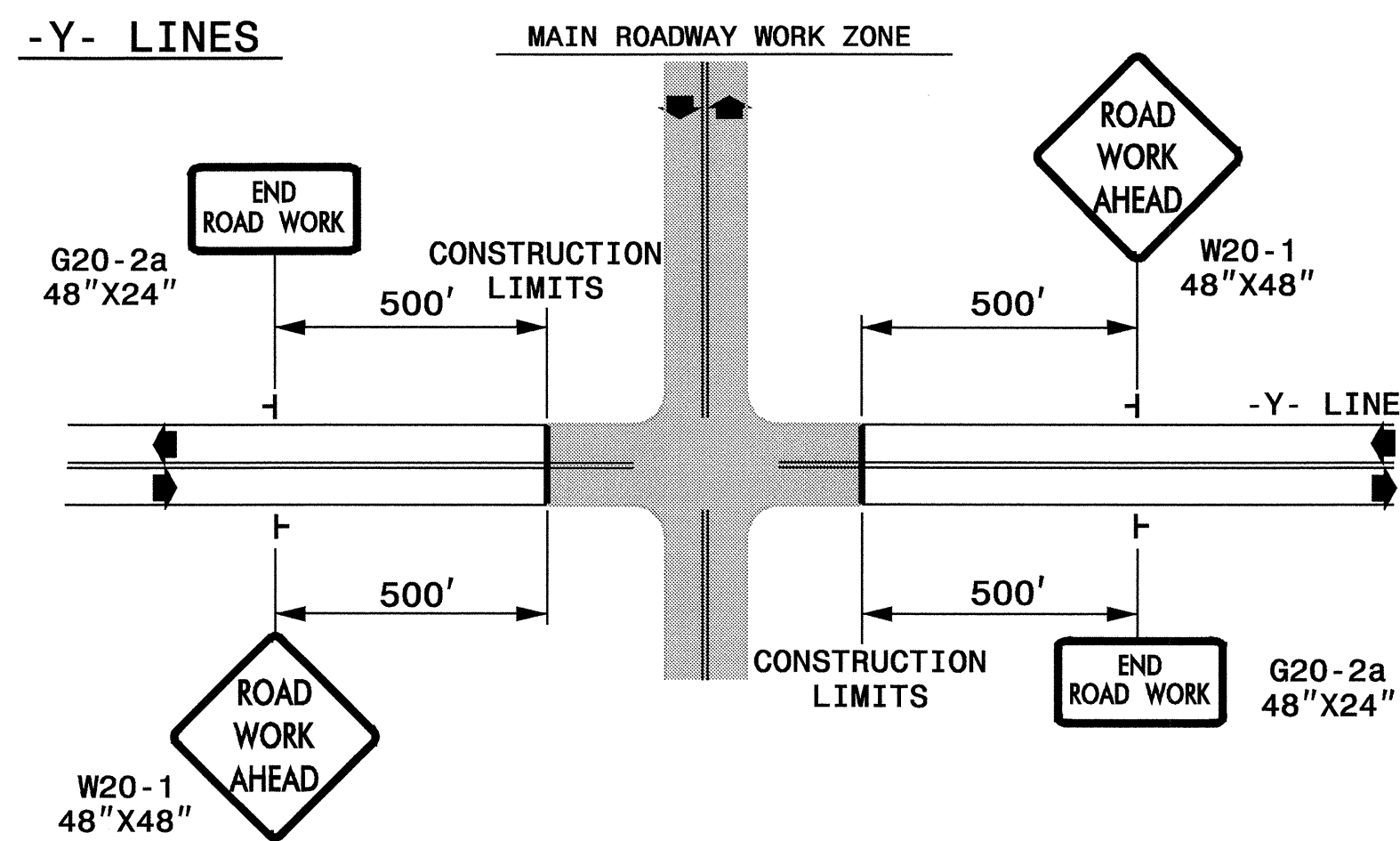

DETAIL DRAWING FOR
TWO-WAY UNDIVIDED
WORK ZONE WARNING SIGNS

GENERAL NOTES

- USE FLUORESCENT ORANGE SHEETING (TYPE VII OR HIGHER) ON ALL ADVANCED WORK ZONE SIGNS.
- DO NOT INSTALL ADVANCE WARNING SIGNS MORE THAN 3 DAYS PRIOR TO BEGINNING OF WORK.
- SIGNS SHOWN ARE REQUIRED FOR WORK ZONES THAT WILL REMAIN IN EFFECT OVERNIGHT. FOR SHORT-TERM DAILY MAINTENANCE TYPE OPERATIONS, THIS SIGNING APPLICATION IS OPTIONAL; MAY USE ONLY APPLICABLE ROADWAY STANDARD DRAWINGS INSTEAD. HOWEVER, IF THIS SIGNING APPLICATION IS USED, SIGNS MAY BE PORTABLE MOUNTED.
- ALL SIGN SPACING DIMENSIONS ARE APPROXIMATE, FIELD ADJUST AS NECESSARY OR AS DIRECTED.
- USE 3LB STEEL U-CHANNEL POST OR 4" X 4" WOOD POST FOR ALL WORK ZONE SIGNS. 3LB STEEL U-CHANNEL POSTS MUST MEET THE REQUIREMENTS OF STANDARD SPECIFICATION SECTION 1094-1(B), MAY BE GALVANIZED STEEL, OR MAY BE PAINTED GREEN BY THE POST MANUFACTURER. SQUARE STEEL TUBING POSTS HAVING EQUIVALENT STRENGTH OF THE 3 LB STEEL U-CHANNEL POST ARE ALSO ACCEPTABLE FOR USE. ERECT SIGNS PER ROADWAY STANDARD DRAWING 1110.01. PAYMENT FOR WOOD POSTS, 3LB STEEL U-CHANNEL AND SQUARE STEEL TUBING POSTS WITH SIGNS WILL BE MADE ACCORDING TO STANDARD SPECIFICATION "WORK ZONE SIGNS" SECTION 1110.
- WHEN NECESSARY, USE SPLICING IN ACCORDANCE WITH ROADWAY STANDARD DRAWING NO. 1110.01. REMOVE ENTIRE POST WHEN REMOVING SIGNS WITH SPLICED POSTS.
- DO NOT BACK BRACE SIGN SUPPORTS.
- ** TWO-WAY UNDIVIDED ADVANCE WARNING SIGN CONFIGURATION MAY BE USED ON URBAN MULTI-LANE FACILITIES WHERE CONDITIONS LIMIT THE USE OF DUAL MOUNTED SIGNS AS DETERMINED BY THE ENGINEER.

LEGEND

- ┆ STATIONARY SIGN
- ◀ DIRECTION OF TRAFFIC FLOW

SHEET 1 OF 1

APPROVED: _____ DATE: _____	DETAIL DRAWING FOR TWO-WAY UNDIVIDED AND URBAN FREEWAYS ADVANCED WORK ZONE WARNING SIGNS	
	SCALE: NONE	REVISIONS
	DATE: 02/08	7-98 10/01
	DWG. BY: DAH	10-98 03/04
	DESIGN BY: DAH	01/01 11/04
REVIEWED BY: JWW	CADD FILE	

19-FEB-2008 09:33
 \\dot\dfs\dot\Pro\TIP\Projects-R\R2502A\TrafficControl\Top\Phase III\NR-2502A_TC_TCP_Phill_38_AWS.dgn
 AT WZTC224241