



FINAL PAVEMENT MARKING SCHEDULE

SYMBOL	DESCRIPTION	FINAL PAVEMENT MARKINGS	PAY ITEM QUANTITY BREAKDOWN	TOTAL QUANTITY
TA	WHITE EDGELINE	<u>THERMOPLASTIC (100MM, 2.3MM)</u>	500 M	TOTAL 500 M
TD	0.5 M. WHITE MINISKIP	<u>THERMOPLASTIC (100MM, 3.1MM)</u>	20 M	
TE	WHITE SOLID LANE LINE		210 M	
TI	YELLOW DOUBLE CENTER		670 M	
				TOTAL 900 M
TT	YELLOW DIAGONAL	<u>THERMOPLASTIC (200MM, 2.3MM)</u>	60 M	TOTAL 60 M
T2	WHITE STOPBAR	<u>THERMOPLASTIC (600MM, 3.1MM)</u>	40 M	TOTAL 40 M
UA	LEFT TURN ARROW	<u>THERMOPLASTIC PAVEMENT MARKING SYMBOLS (2.3MM)</u>	40 EA	
UB	RIGHT TURN ARROW		50 EA	
UC	STRAIGHT ARROW		10 EA	
				TOTAL 100 EA
VA	WHITE EDGELINE	<u>POLYUREA (100MM)</u>	37,820 M	
VB	YELLOW EDGELINE		35,550 M	
VC	3 M. WHITE SKIP		8740 M	
VD	0.5 M. WHITE MINISKIP		240 M	
VE	WHITE SOLID LANE LINE		860 M	
VI	YELLOW DOUBLE CENTER		2960 M	
				TOTAL 86,170 M
VP	WHITE GORELINE	<u>POLYUREA (200MM)</u>	5050 M	
VQ	WHITE DIAGONAL		780 M	
VT	YELLOW DIAGONAL		100 M	
				TOTAL 5930 M
V2	WHITE STOPBAR	<u>POLYUREA (600MM)</u>	160 M	TOTAL 160 M
MA	YELLOW & YELLOW	<u>PERMANENT RAISED PAVEMENT MARKERS</u>	70 EA	TOTAL 70 EA
		<u>SNOWPLOWABLE RAISED PAVEMENT MARKERS</u>		
ME	YELLOW & YELLOW		151 EA	
MF	CRYSTAL & RED		2695 EA	
				TOTAL 2846 EA
		<u>FLEXIBLE DELINEATORS</u>		
	CRYSTAL		80 EA	
	YELLOW		80 EA	
				TOTAL 160 EA

NOTES:

PAVEMENT MARKERS

SPACE SNOWPLOWABLE PAVEMENT MARKERS ALONG SKIP LINES AND CENTERLINES AT 24M CENTERS.

SPACE SNOWPLOWABLE PAVEMENT MARKERS ALONG SOLID TURN LANE LINES AND GORE LINES AT 6M CENTERS.

SPACE RAISED PAVEMENT MARKERS (YELLOW) ON RAISED CONCRETE ISLANDS AT 12M CENTERS.

FOR ADDITIONAL INFORMATION PERTAINING TO MARKERS, SEE RSD 1250.01, 1251.01, AND 1253.01.

PAVEMENT MARKING SYMBOLS

FOR LEFT AND RIGHT TURN BAYS ALONG -L-, USE 3 TURN ARROWS AT 70M CENTERS.

FOR ADDITIONAL INFORMATION PERTAINING TO PAVEMENT MARKING SYMBOLS, SEE RSD 1205.04, 1205.05 AND 1205.06.

16-MAY-2008 10:25
 \D01\dfsro010\p\rc\N\hibproj\jects-r\2206ba\trafficoontra\top\pavement mar\kings\2206ba-tc-0\bmp.dgn
 dapor\ker AT\MZ10224100

APPROVED: 	FINAL PAVEMENT MARKING SCHEDULE	<table border="1" style="width: 100%; border-collapse: collapse;"> <tr> <td>SCALE: NONE</td> <td rowspan="4" style="text-align: center;"></td> </tr> <tr> <td>DATE: 5/08</td> </tr> <tr> <td>DWG. BY: DVJ</td> </tr> <tr> <td>DESIGN BY: DVJ</td> </tr> <tr> <td>REVIEWED BY: DAP</td> <td></td> </tr> </table>	SCALE: NONE		DATE: 5/08	DWG. BY: DVJ	DESIGN BY: DVJ	REVIEWED BY: DAP		
SCALE: NONE										
DATE: 5/08										
DWG. BY: DVJ										
DESIGN BY: DVJ										
REVIEWED BY: DAP										
		<table border="1" style="width: 100%; border-collapse: collapse;"> <tr> <th colspan="2">REVISIONS</th> </tr> <tr> <td style="width: 50%;"> </td> <td style="width: 50%;"> </td> </tr> <tr> <td> </td> <td> </td> </tr> <tr> <td> </td> <td> </td> </tr> </table>	REVISIONS							
REVISIONS										

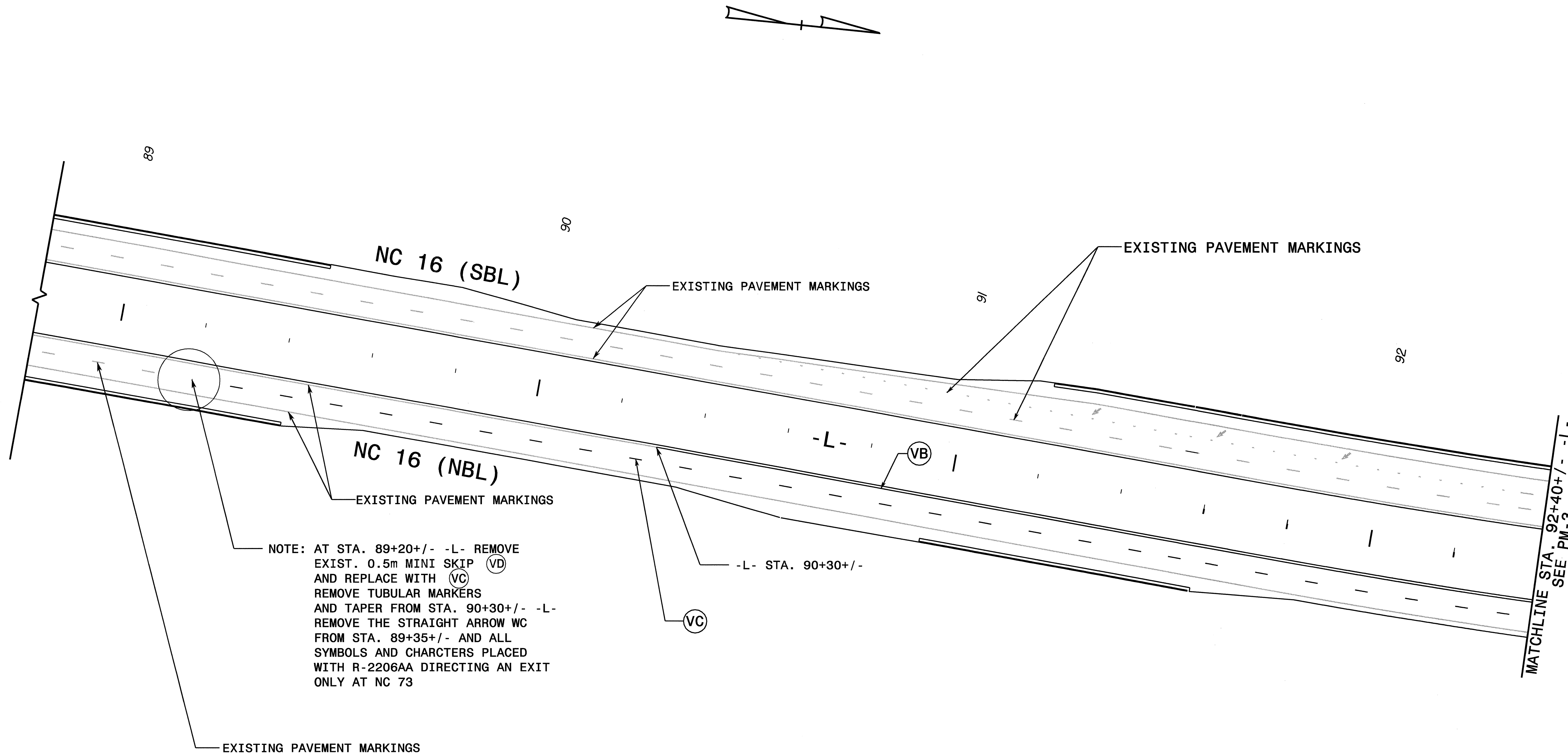

16-MAY-2008 10:27
 \\dot\dfs\0070\Proj\1\p\projects-r\2206ba\traffic\top\pavement markings-r\2206ba-rc-02pmp.dgn
 adparker AT WZ122400

APPROVED: DATE: 5/14/08	FINAL PAVEMENT MARKINGS	
SCALE: NONE		REVISIONS
DATE: 11/07		
DWG. BY: DVJ		
DESIGN BY: DVJ		
REVIEWED BY: DAP		



PROJ. REFERENCE NO. R-2206BA & CA	SHEET NO. PM-3
--------------------------------------	-------------------

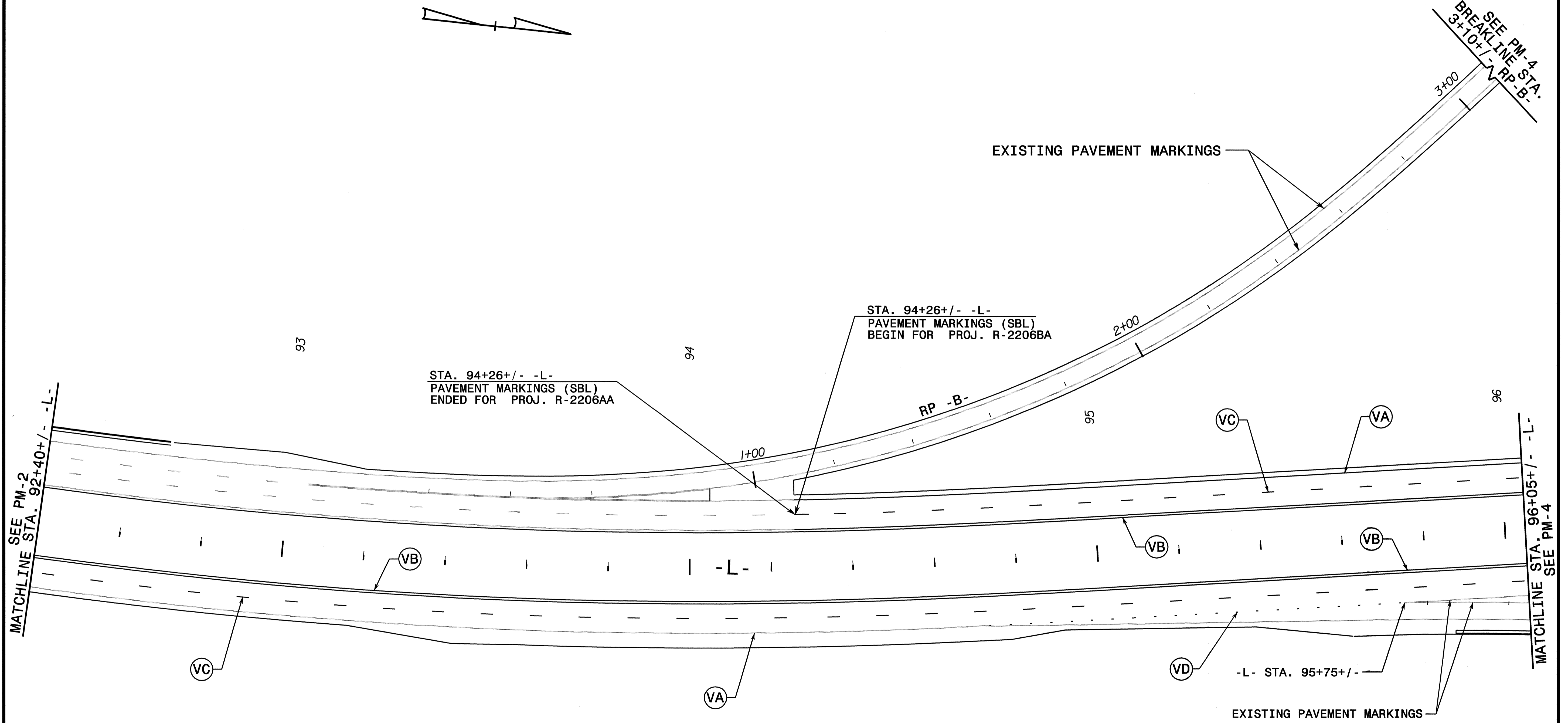
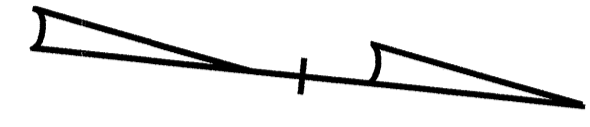

16-MAY-2008 10:28 \\dot\dfsroot\10\p\proj\traffic\trafficcontrol\top\pavement markings\2206ba-ca_03pmp.dgn

APPROVED: *[Signature]* DATE: 5/14/08

SEAL

FINAL PAVEMENT MARKINGS

SCALE: NONE		REVISIONS
DATE: 11/07		
DWG. BY: DVJ		
DESIGN BY: DVJ		
REVIEWED BY: DAP		

CADD FILE

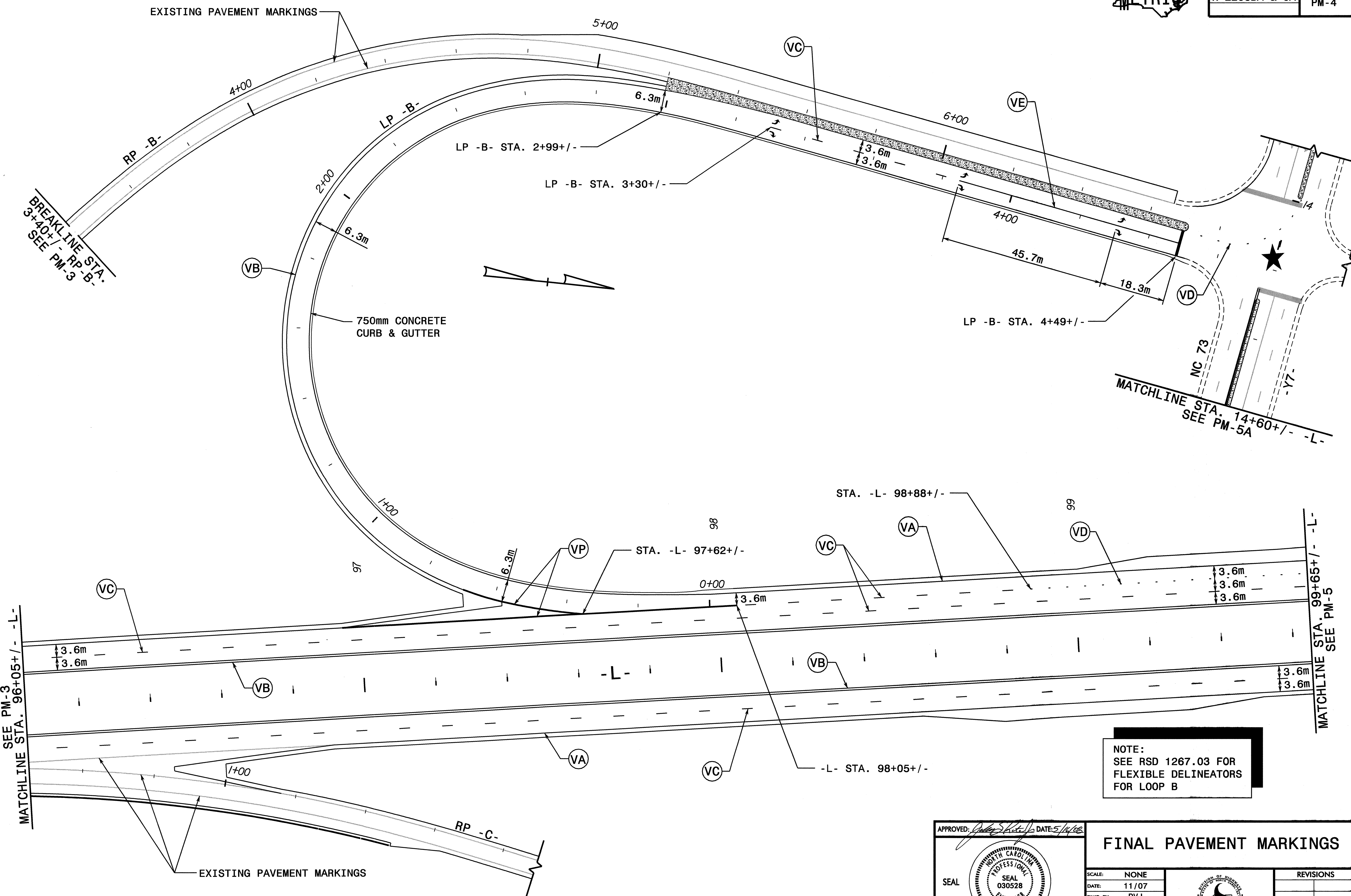

NOTE:
SEE RSD 1267.03 FOR
FLEXIBLE DELINEATORS
FOR LOOP B

APPROVED: *[Signature]* DATE: 5/14/08

 SEAL

FINAL PAVEMENT MARKINGS

SCALE: NONE		REVISIONS
DATE: 11/07		
DWG. BY: DVJ		
DESIGN BY: DVJ		
REVIEWED BY: DAP		

16-MAY-2008 10:32
 \\dot\dfs\oo\0\Pro\1\p\projects-r\2206ba\traffic\top\pavement markings-r\2206ba_fc_04pmp.dgn
 dpar\ker AT WZ1C224100



PROJ. REFERENCE NO. R-2206BA & CA	SHEET NO. PM-5
--------------------------------------	-------------------

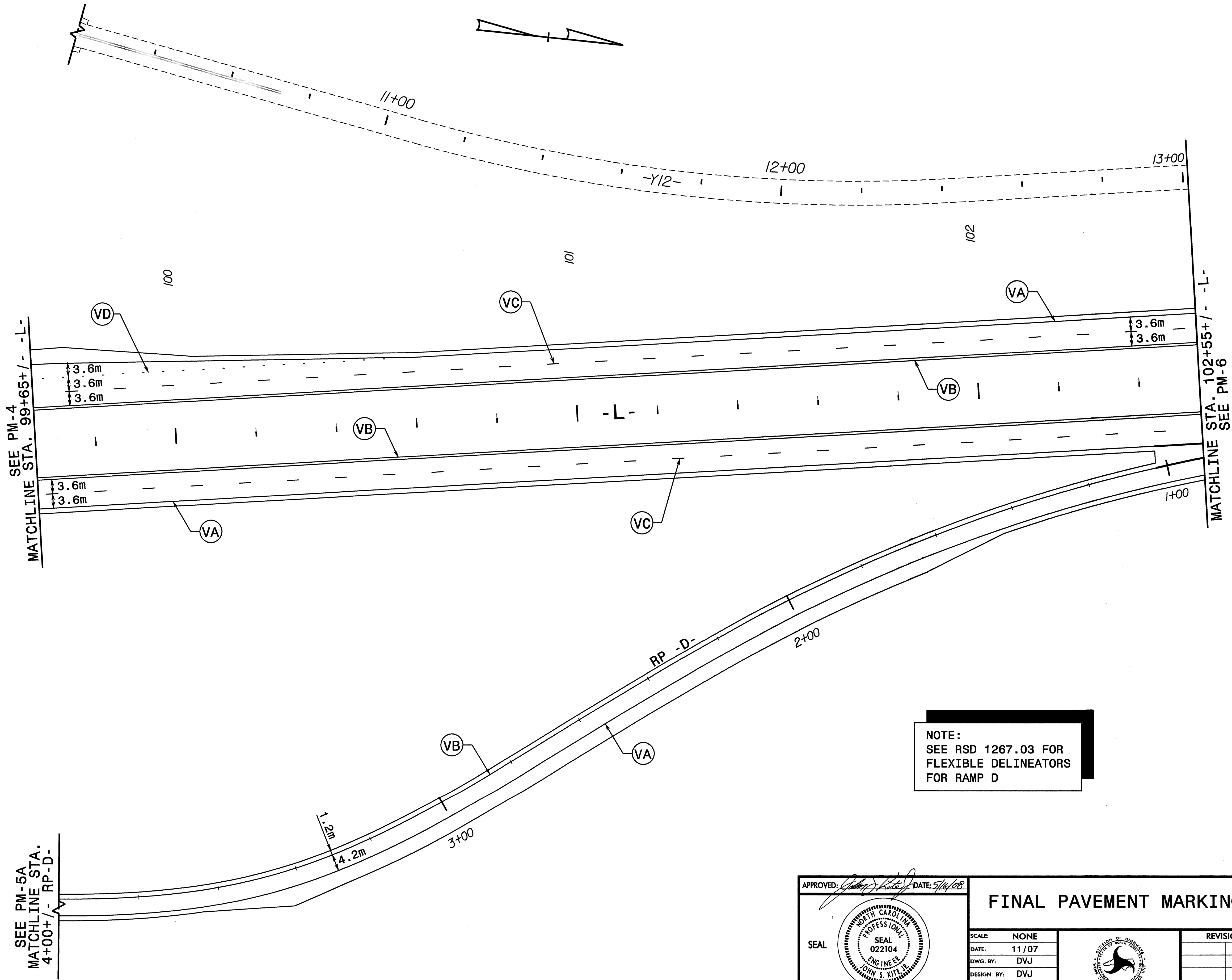

NOTE:
SEE RSD 1267.03 FOR
FLEXIBLE DELINEATORS
FOR RAMP D

APPROVED:	DATE: 5/14/07	FINAL PAVEMENT MARKINGS							
SCALE: NONE	DATE: 11/07								
DWG. BY: DVJ	DESIGN BY: DVJ								
REVIEWED BY: DAP									
		<table border="1"> <thead> <tr> <th colspan="2">REVISIONS</th> </tr> </thead> <tbody> <tr> <td> </td> <td> </td> </tr> <tr> <td> </td> <td> </td> </tr> </tbody> </table>		REVISIONS					
REVISIONS									

16-MAY-2008 10:35
 \\dot\dfsroot\10\Pro\11\pprojects-r\2206ba\traffic\trafficcontrol\top\pavement markings-r-2206ba-rc-05bpm.dgn
 daprker AT WZTC24100



PROJ. REFERENCE NO.	SHEET NO.
R-2206BA & CA	PM-5a

SEE PM-4
MATCHLINE STA.
2+10+/- RP-C-

RP -C-

(UD)

(UD)

3+00

EXISTING PAVEMENT MARKINGS

(UE)

(UE)

(T2)

(VA)

RP -D-

(VB)

(TE)

-Y7-

(VD)

99

NC 73

EXTEND (TI) TO STOP BAR

NOTE: SEE PM-4 FOR NC 16 PAVEMENT MARKINGS UNDER NC 73

NOTE: EXIST. (UC) STRAIGHT ARROWS TO BE CHANGED TO (UE) COMBINATION STRAIGHT/RIGHT ARROWS

MATCHLINE STA.
4+00+/- RP-D-
PM-6

MATCHLINE STA. 14+60+/- -Y7-
SEE PM-5

APPROVED: DATE: 5/14/08

SEAL

FINAL PAVEMENT MARKINGS

SCALE:	NONE
DATE:	11/07
DWG. BY:	DVJ
DESIGN BY:	DVJ
REVIEWED BY:	DAP

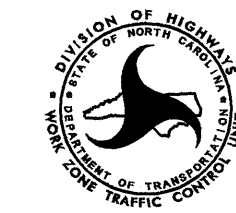

REVISIONS	

I6-MAY-2008 10:34
 \\Dc1dgsr0910\p\proj\1600\traffic\traffic\top\pavement markings\2206ba-ca_05apmp.dgn
 adparker AT 11/22/08



PROJ. REFERENCE NO.	SHEET NO.
R-2206BA & CA	PM-6

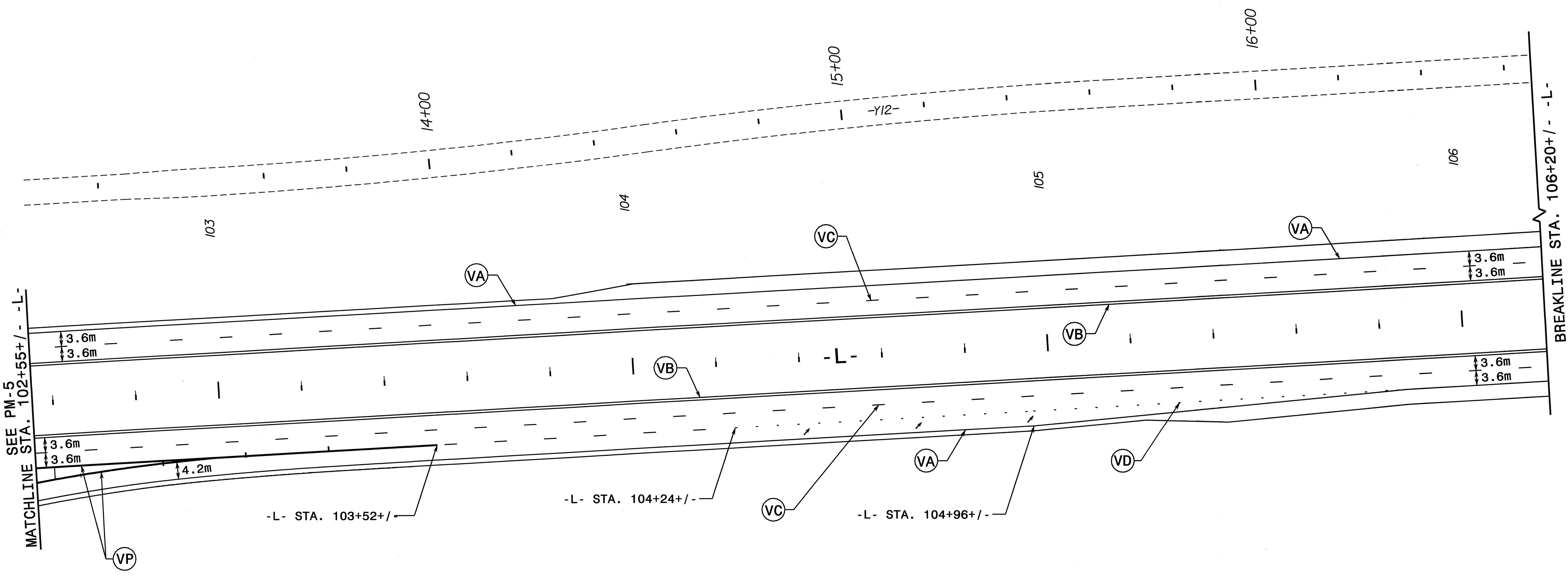
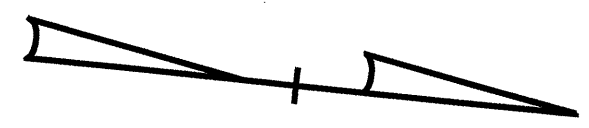

16-MAY-2008 10:36
 \\dot\dfsroot\10\pro\hpbprojects-r\2206ba\traffic\trafficcontrol\top\pavement markings-r\2206ba_fc_06pmp.dgn
 daprker AT WZTC22400

APPROVED: *[Signature]* DATE: 5/16/08

SEAL

SEAL 022104
 ENGINEER
 JOHN S. KITE, II

FINAL PAVEMENT MARKINGS

SCALE:	NONE
DATE:	11/07
DWG. BY:	DVJ
DESIGN BY:	DVJ
REVIEWED BY:	DAP

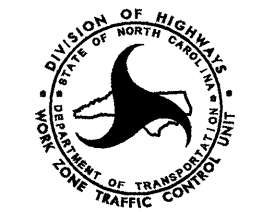



REVISIONS	

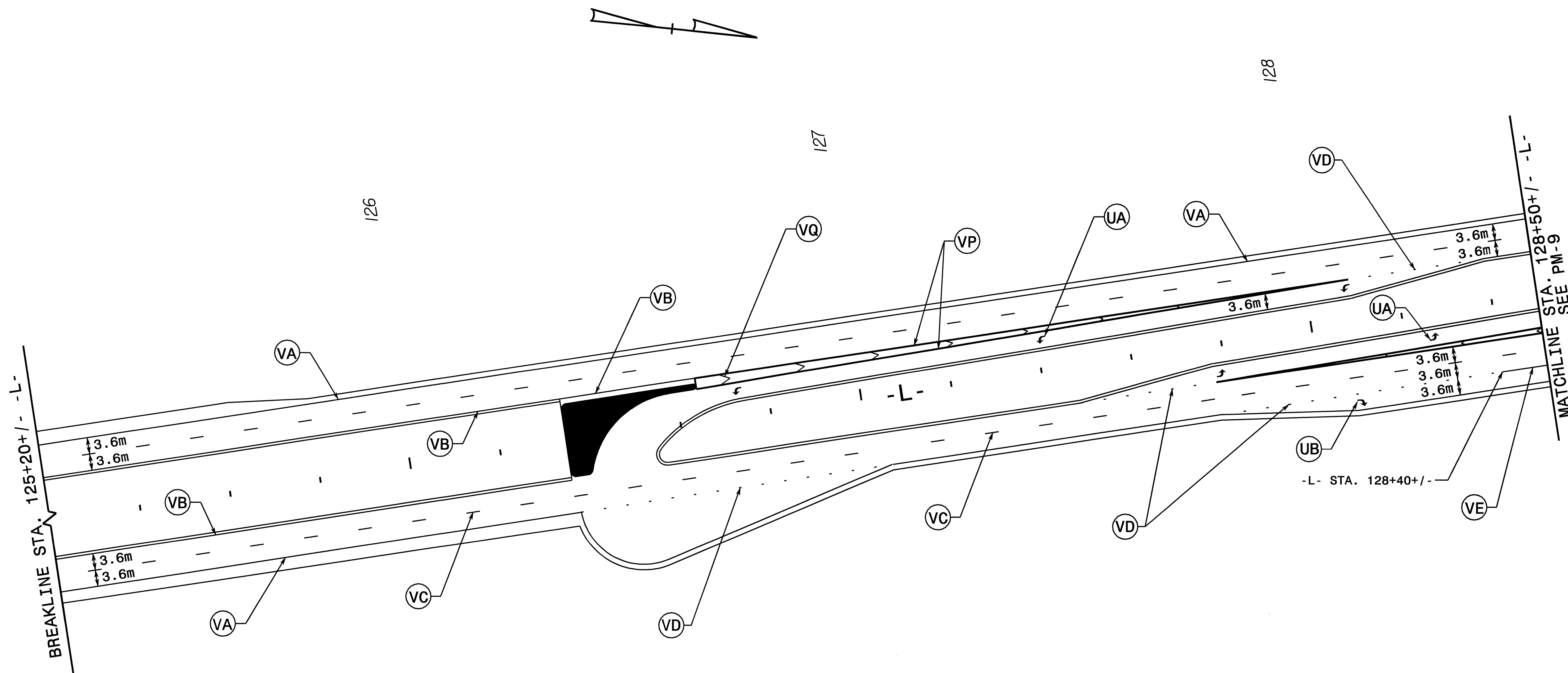

PROJ. REFERENCE NO. R-2206BA & CA	SHEET NO. PM-7
--------------------------------------	-------------------



I6-MAY-2008 10:41
 \\dot\dfs\root01\Proj\11\p\projects-r\2206ba\traffic\control\top\pavement markings-r-2206ba-rc-08bpm.dgn
 adparker AT: WZTC2400

APPROVED: <i>[Signature]</i> DATE: <i>5/1/07</i>	FINAL PAVEMENT MARKINGS		<table border="1"> <tr> <th colspan="2">REVISIONS</th> </tr> <tr> <td> </td> <td> </td> </tr> </table>		REVISIONS												
REVISIONS																	
	<table border="1"> <tr> <td>SCALE:</td> <td>NONE</td> </tr> <tr> <td>DATE:</td> <td>11/07</td> </tr> <tr> <td>DWG. BY:</td> <td>DVJ</td> </tr> <tr> <td>DESIGN BY:</td> <td>DVJ</td> </tr> <tr> <td>REVIEWED BY:</td> <td>DAP</td> </tr> </table>	SCALE:	NONE	DATE:	11/07	DWG. BY:	DVJ	DESIGN BY:	DVJ	REVIEWED BY:	DAP		<table border="1"> <tr> <td>CADD</td> <td> </td> </tr> <tr> <td>FILE</td> <td> </td> </tr> </table>	CADD		FILE	
SCALE:	NONE																
DATE:	11/07																
DWG. BY:	DVJ																
DESIGN BY:	DVJ																
REVIEWED BY:	DAP																
CADD																	
FILE																	



PROJ. REFERENCE NO. R-2206BA & CA	SHEET NO. PM-8
--------------------------------------	-------------------

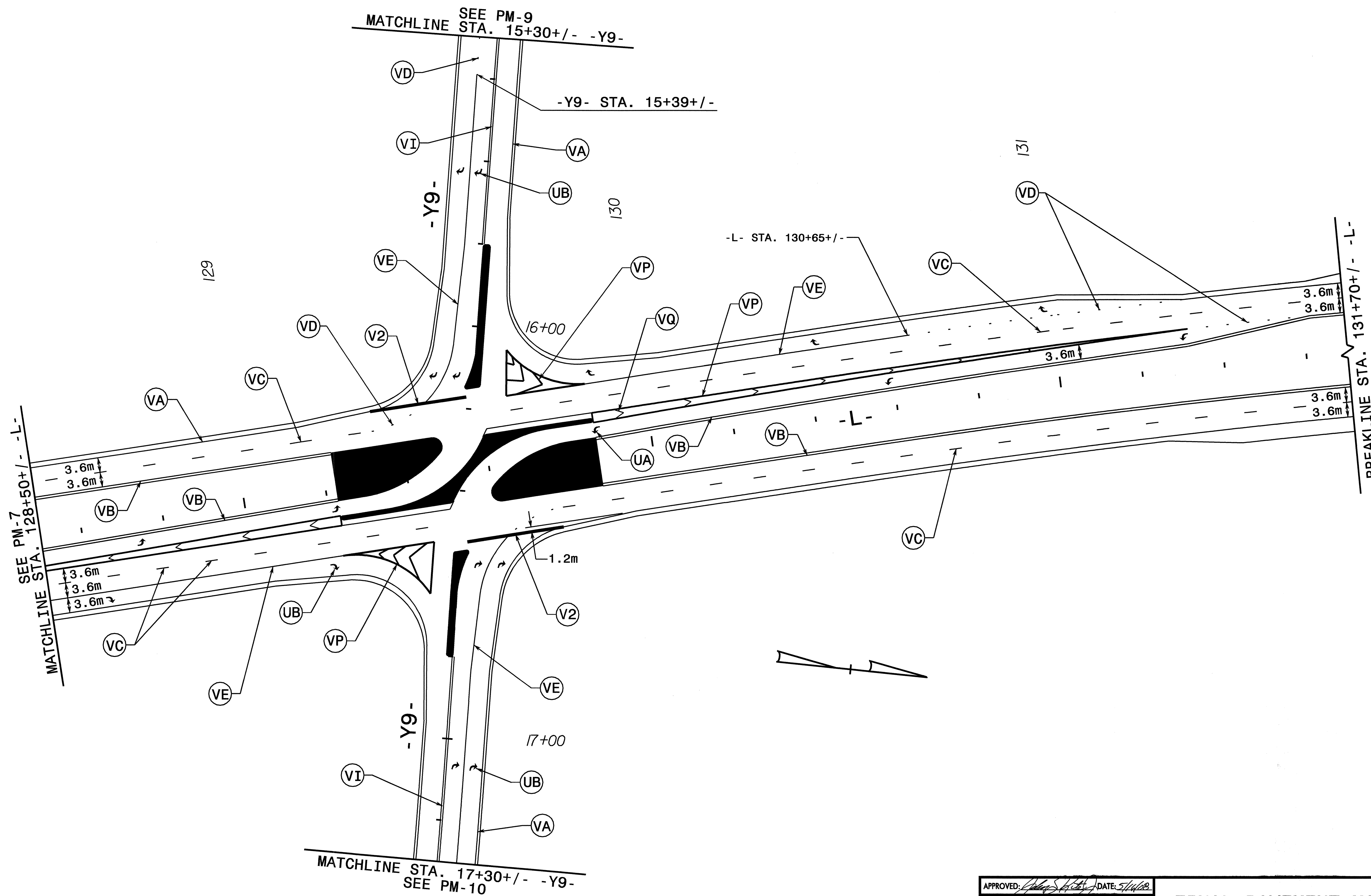

16-MAY-2008 10:45
 \\dot\dfs\09101\PROJ\11\p\projects-r\2206ba\traffic\top\pavement markings-r\2206ba-rc_09pmp.dgn
 gdparker AT WZTC2400

APPROVED: DATE: 5/14/08		FINAL PAVEMENT MARKINGS									
SCALE:	NONE										
DATE:	11/07										
DWG. BY:	DVJ										
DESIGN BY:	DVJ										
REVIEWED BY:	DAP	<table border="1"> <thead> <tr> <th colspan="2">REVISIONS</th> </tr> </thead> <tbody> <tr> <td> </td> <td> </td> </tr> <tr> <td> </td> <td> </td> </tr> <tr> <td> </td> <td> </td> </tr> </tbody> </table>		REVISIONS							
REVISIONS											



PROJ. REFERENCE NO. R-2206BA & CA	SHEET NO. PM-9
--------------------------------------	-------------------

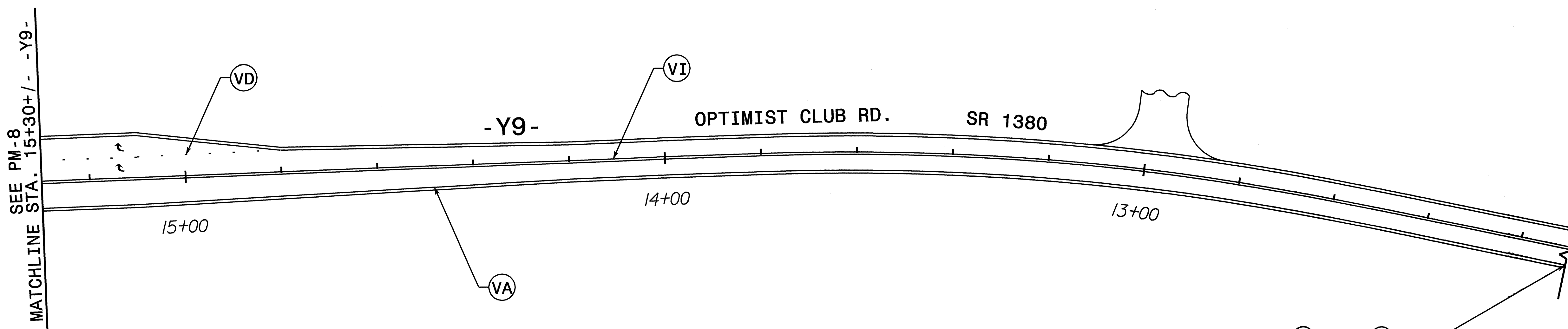

NOTE: PAVEMENT MARKINGS (VI) AND (VA) TO BE CONTINUED TO -Y9- STA. 11+09+/- TIE TO EXISTING

16-MAY-2008 10:46
\\dot\vgfrsro010\p\top\projects-r\2206bc\traffic\trafficcontrol\top\pavement markingsr-2206bc.tc_limp.dgn
paper

APPROVED: *[Signature]* DATE: 5/14/08

SEAL

STATE OF NORTH CAROLINA
PROFESSIONAL
SEAL
022104
ENGINEER
JOHN S. NITE, II

FINAL PAVEMENT MARKINGS

SCALE: NONE		REVISIONS
DATE: 11/07		
DWG. BY: DVJ		
DESIGN BY: DVJ		
REVIEWED BY: DAP		



PROJ. REFERENCE NO.	SHEET NO.
R-2206BA & CA	PM-10

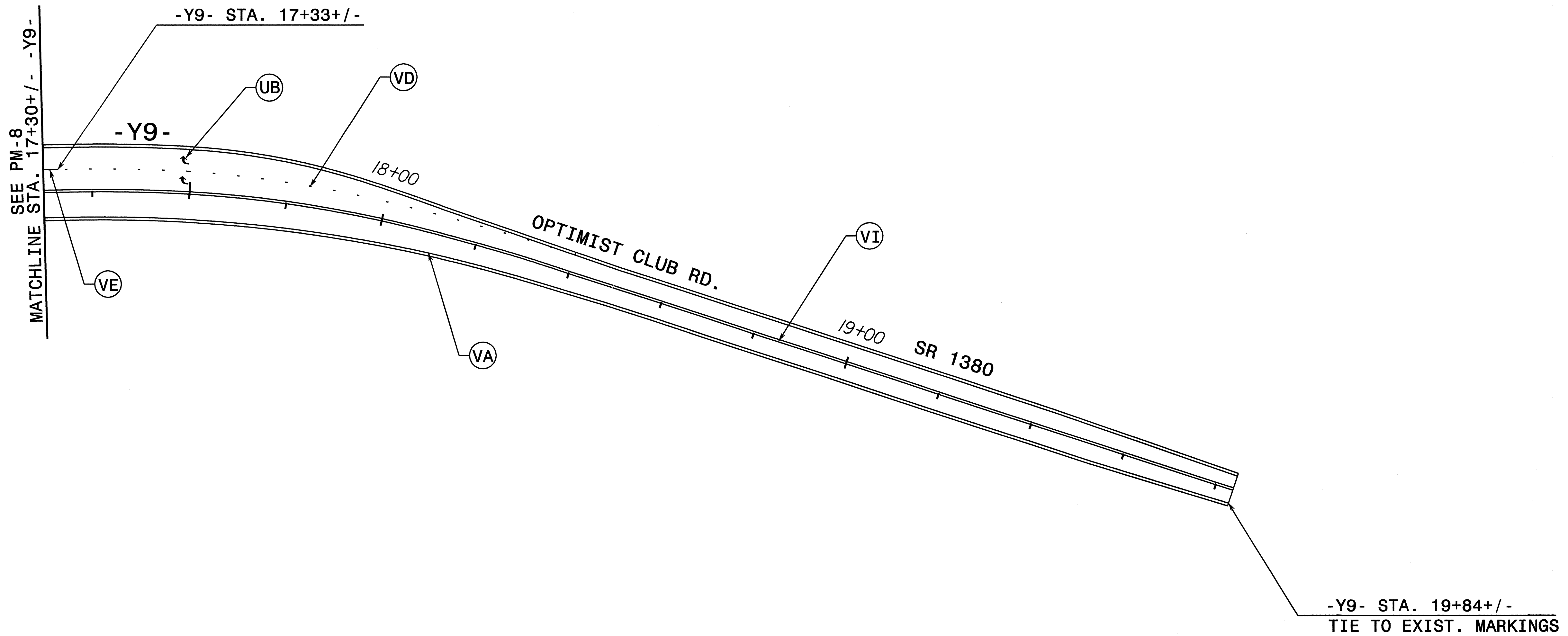

16-MAY-2008 10:47
 \\dot\dfsroot\01\p\proj\projects\r\2206ba\traffic\trafficcontrol\top\pavement markings\r-2206ba_tc_12bmp.dgn
 daprker AT WZTC224100

APPROVED: *John S. Kite* DATE: 5/16/07

FINAL PAVEMENT MARKINGS

SCALE:	NONE
DATE:	11/07
DWG. BY:	DVJ
DESIGN BY:	DVJ
REVIEWED BY:	DAP

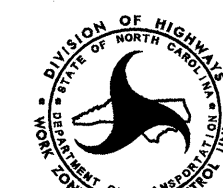

REVISIONS	

CADD FILE



NOTE: PAVEMENT MARKINGS (TI) AND (TA) TO BE CONTINUED TO -Y10- STA. 10+72+/- TIE TO EXISTING

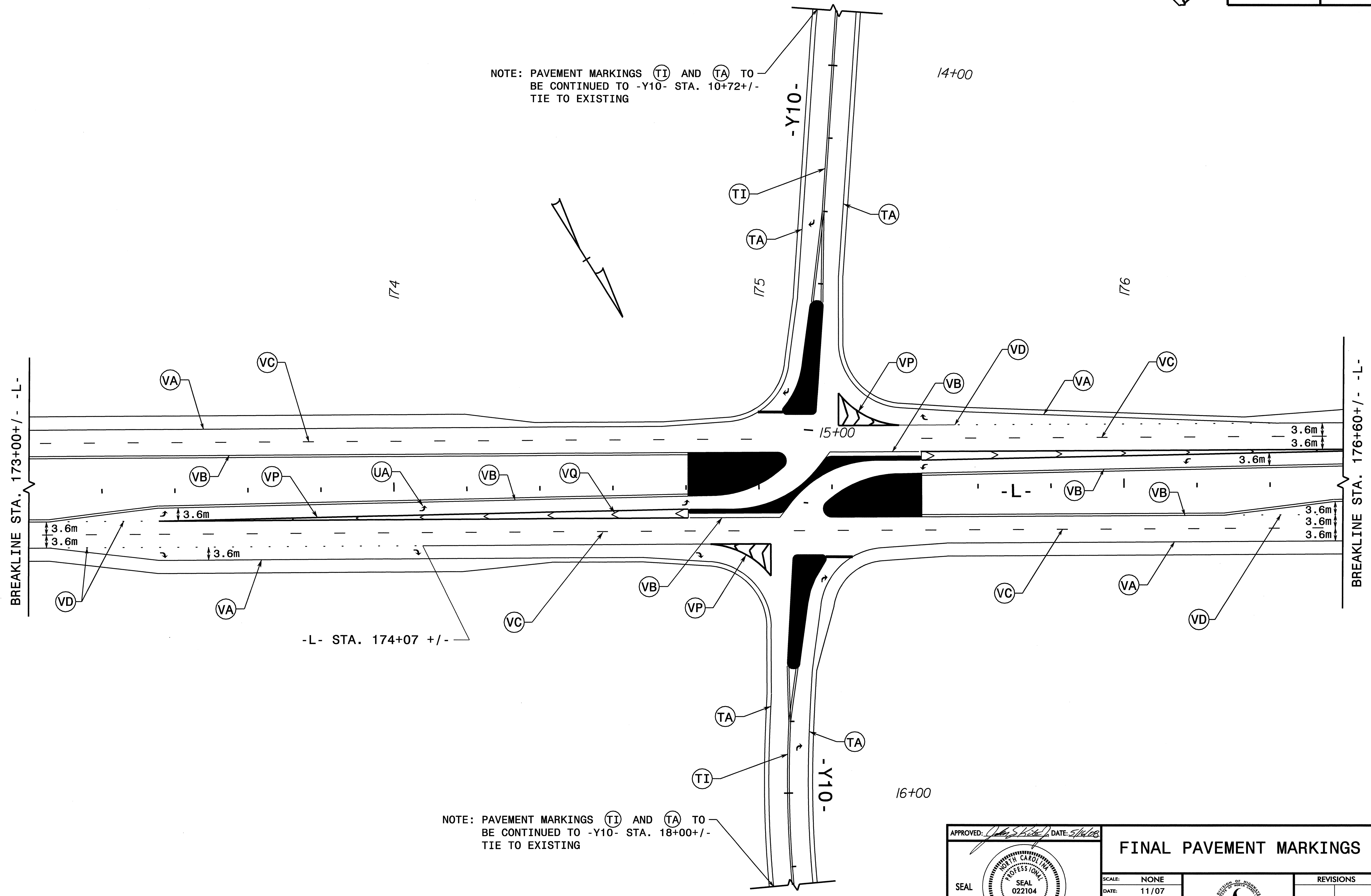

NOTE: PAVEMENT MARKINGS (TI) AND (TA) TO BE CONTINUED TO -Y10- STA. 18+00+/- TIE TO EXISTING

APPROVED: *[Signature]* DATE: 5/14/08

SEAL

FINAL PAVEMENT MARKINGS

SCALE: NONE
DATE: 11/07
DWG. BY: DVJ
DESIGN BY: DVJ
REVIEWED BY: DAP

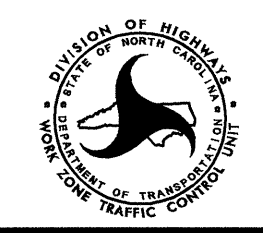

REVISIONS	

16-MAY-2008 14:07 \\dot\dfsroot\01\Proj\1\pprojects-r\2206ba\traffic\control\top\pavement markings-r-2206ba-rc-14pmp.dgn dgarner AT WZTC24100



PROJ. REFERENCE NO. R-2206BA & CA	SHEET NO. PM-12
--------------------------------------	--------------------

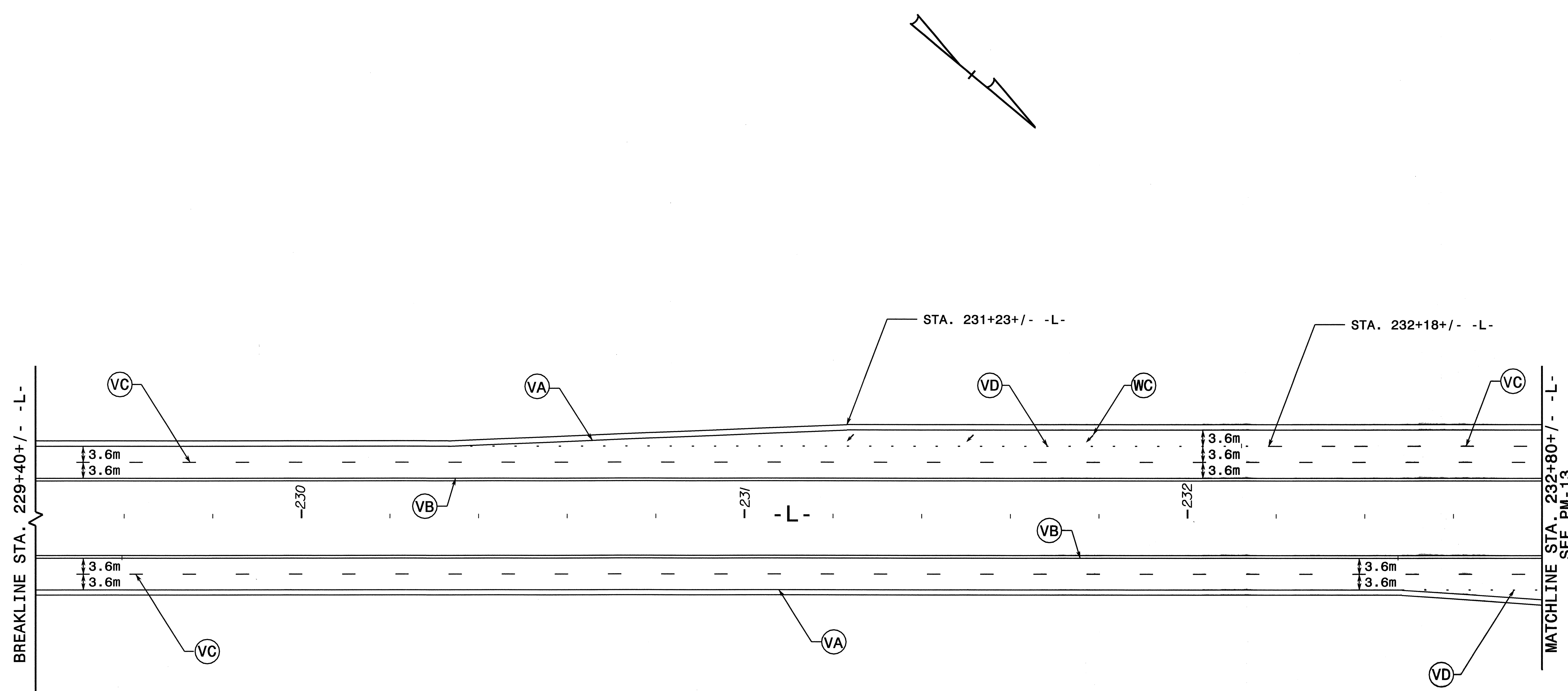

I6-MAY-2008 11:09
 \\dot\dfsro0101\Proj\11p\projects-r\2206bc\traffic\trafficcontrol\top\pavement markings\vr-2206bc.tc_18pmp.dgn
 cadparker AT WZTC224100

APPROVED: *John S. Kite* DATE: 5/4/08

SEAL

FINAL PAVEMENT MARKINGS

SCALE: NONE
 DATE: 11/07
 DWG. BY: DVJ
 DESIGN BY: DVJ
 REVIEWED BY: DAP

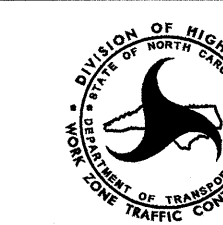

REVISIONS	

CADD FILE

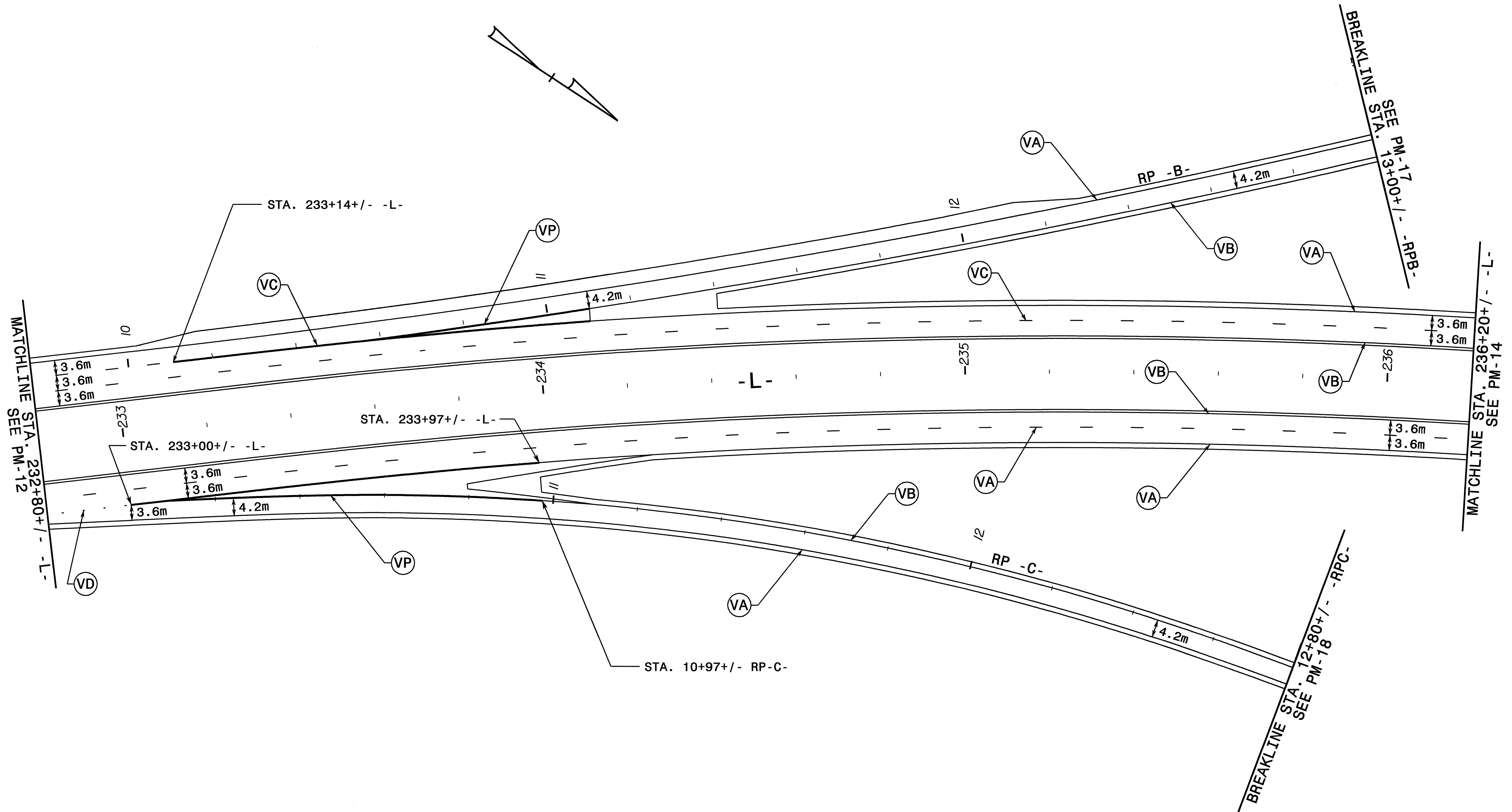

NOTE:
SEE RSD 1267.03 FOR
FLEXIBLE DELINEATORS
FOR RAMP C

APPROVED: *[Signature]* DATE: 5/14/08

SEAL

FINAL PAVEMENT MARKINGS

SCALE: NONE		REVISIONS
DATE: 11/07		
DWG. BY: DVJ		
DESIGN BY: DVJ		
REVIEWED BY: DAP		

I6-MAY-2008 11:00
 \\dot\dfsro0101\Proj\Nipp\projects-r\2206ba\traffic\control\top\pavement markings\2206ba_fc_19pmp.dgn
 ddarker AT WZTC22400

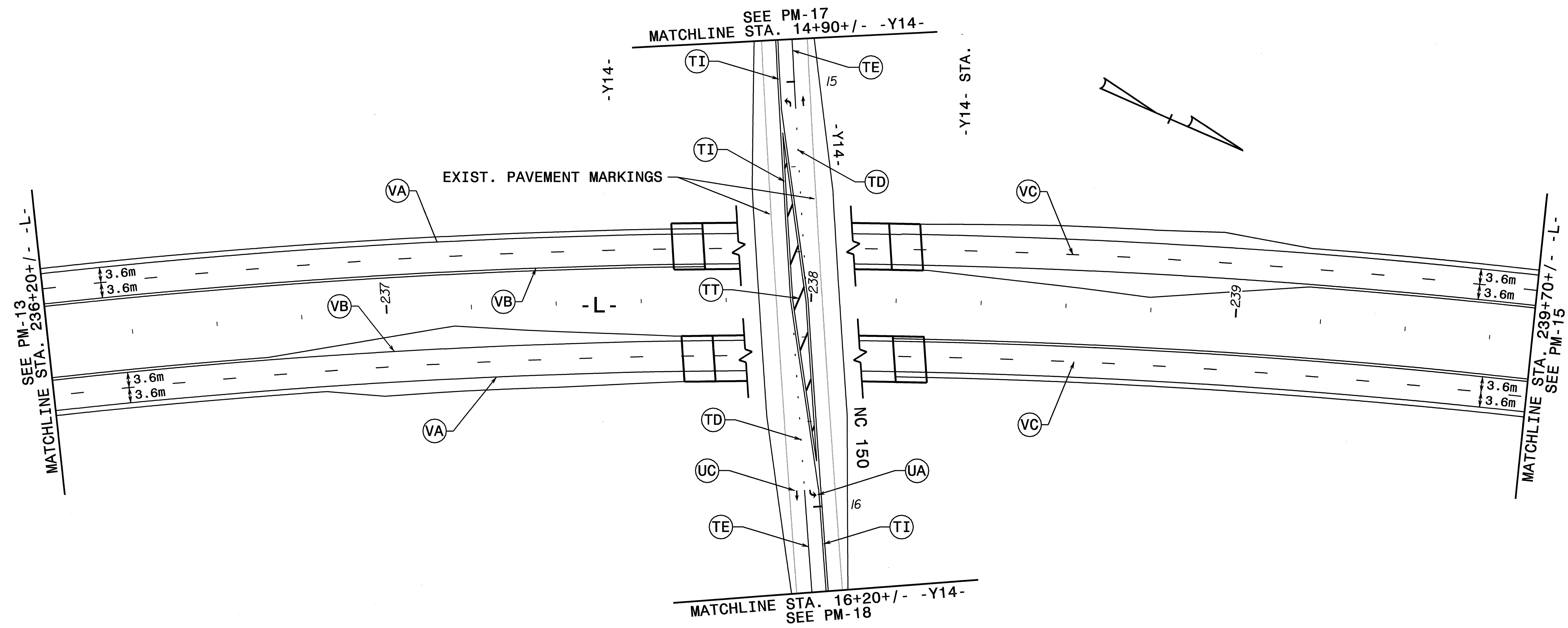

APPROVED: *[Signature]* DATE: 5/16/08

FINAL PAVEMENT MARKINGS

SCALE: NONE		REVISIONS
DATE: 11/07		
DWG. BY: DVJ		
DESIGN BY: DVJ		
REVIEWED BY: DAP		

SEAL

I6-MAY-2008 12:38
 \\dot\dfs\proj\01\Proj\Tipp\projects-r\2206ba\traffic\control\top\pavement markings\2206ba.tc_20pmp.dgn
 ddparker AT WZTC22400



PROJ. REFERENCE NO. R-2206BA & CA	SHEET NO. PM-15
--------------------------------------	--------------------

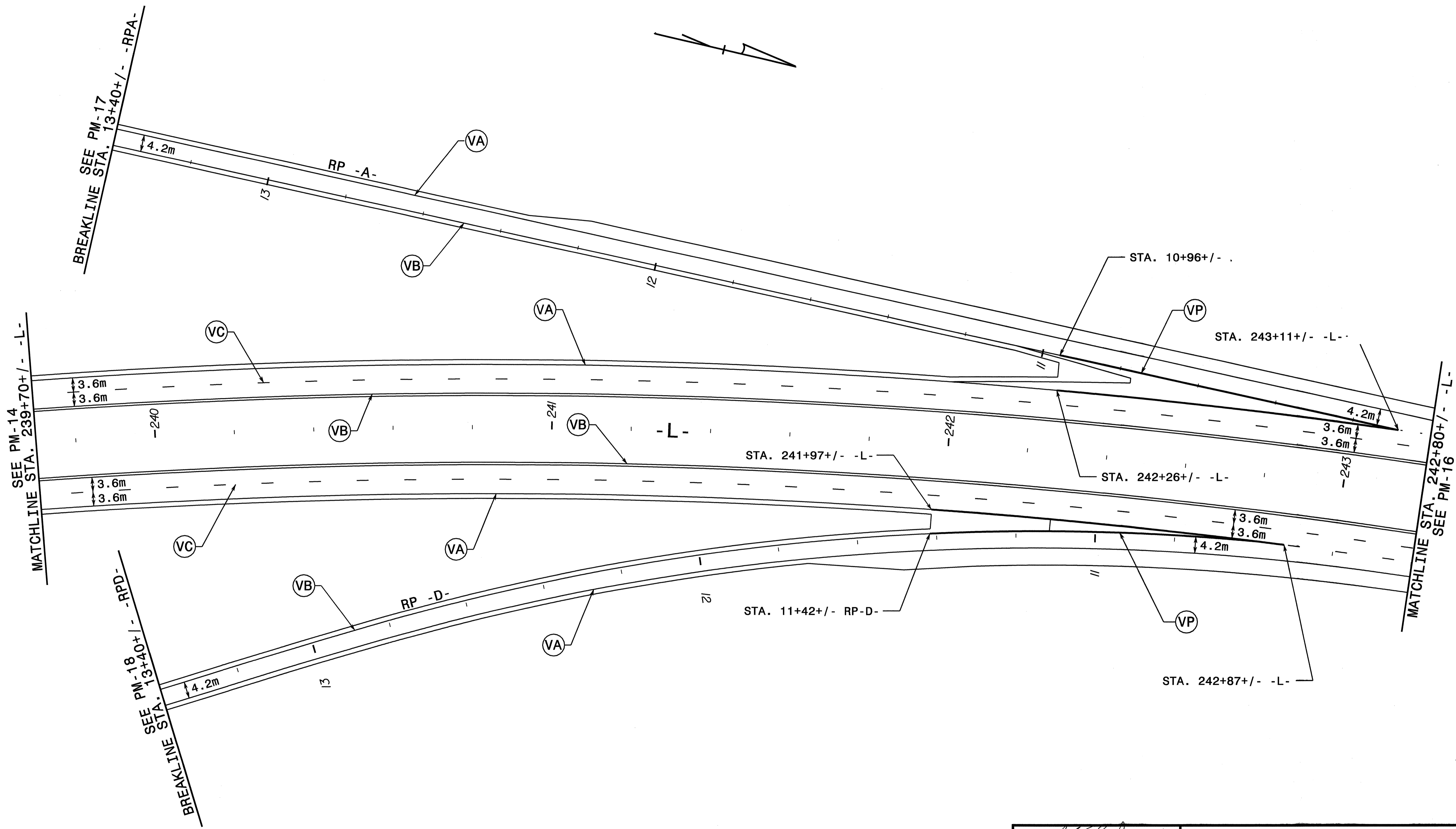

16-MAY-2008 11:33
 \\dot\dfsroot\01\Proj\Ntip\projects-r\2206bc\traffic\top\pavement markings\2206bc.tc_2lpmp.dgn
 daparker AT WZTC224100

APPROVED: *[Signature]* DATE: 5/14/08

SEAL

FINAL PAVEMENT MARKINGS

SCALE: NONE
 DATE: 11/07
 DWG. BY: DVJ
 DESIGN BY: DVJ
 REVIEWED BY: DAP

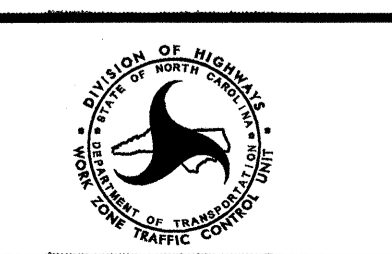

NO.	REVISIONS



PROJ. REFERENCE NO. R-2206BA & CA	SHEET NO. PM-16
--------------------------------------	--------------------

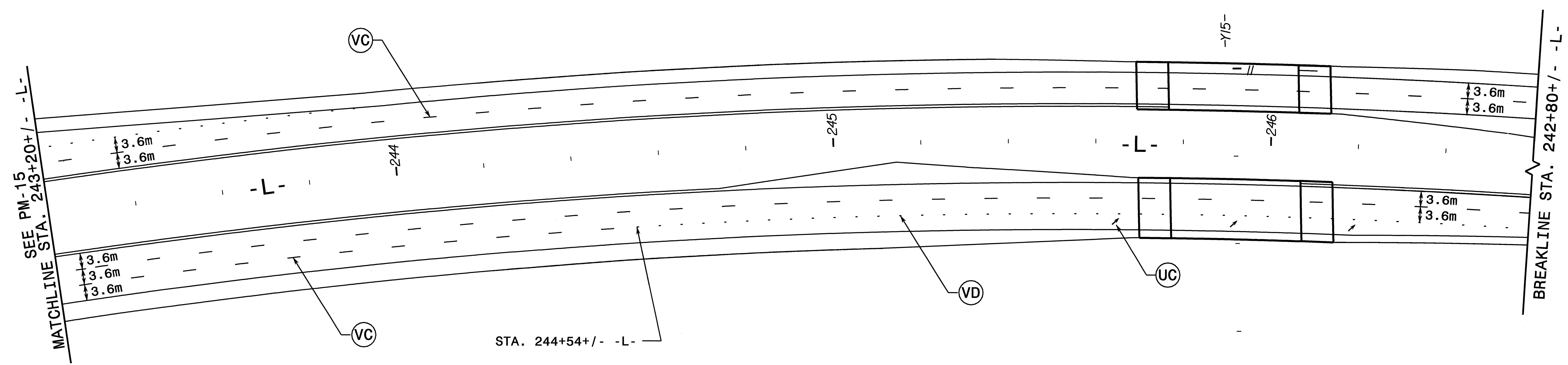
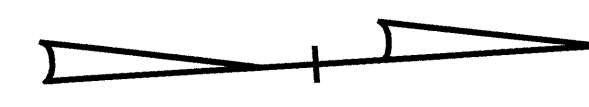

16-MAY-2008 14:53
 \\dot\dfsroot\01\Proj\N\ipproj\projects-r\2206ba\traffic\trafficcontrol\Top\pavement markings-r-2206ba_fc_22bmp.dgn
 gdparker AT WZTC224100

APPROVED: *[Signature]* DATE: 5/16/08

SEAL

FINAL PAVEMENT MARKINGS

SCALE: NONE		REVISIONS
DATE: 11/07		
DWG. BY: DVJ		
DESIGN BY: DVJ		
REVIEWED BY: DAP		CADD FILE



I6-MAY-2008 12:43
 \\dot\dfs\00101\Proj\11pp\projects-r\2206ba\traffic\trafficcontrol\top\pavement markings-r-2206ba-tc-23bmp.dgn
 daparker AT WZTC224100

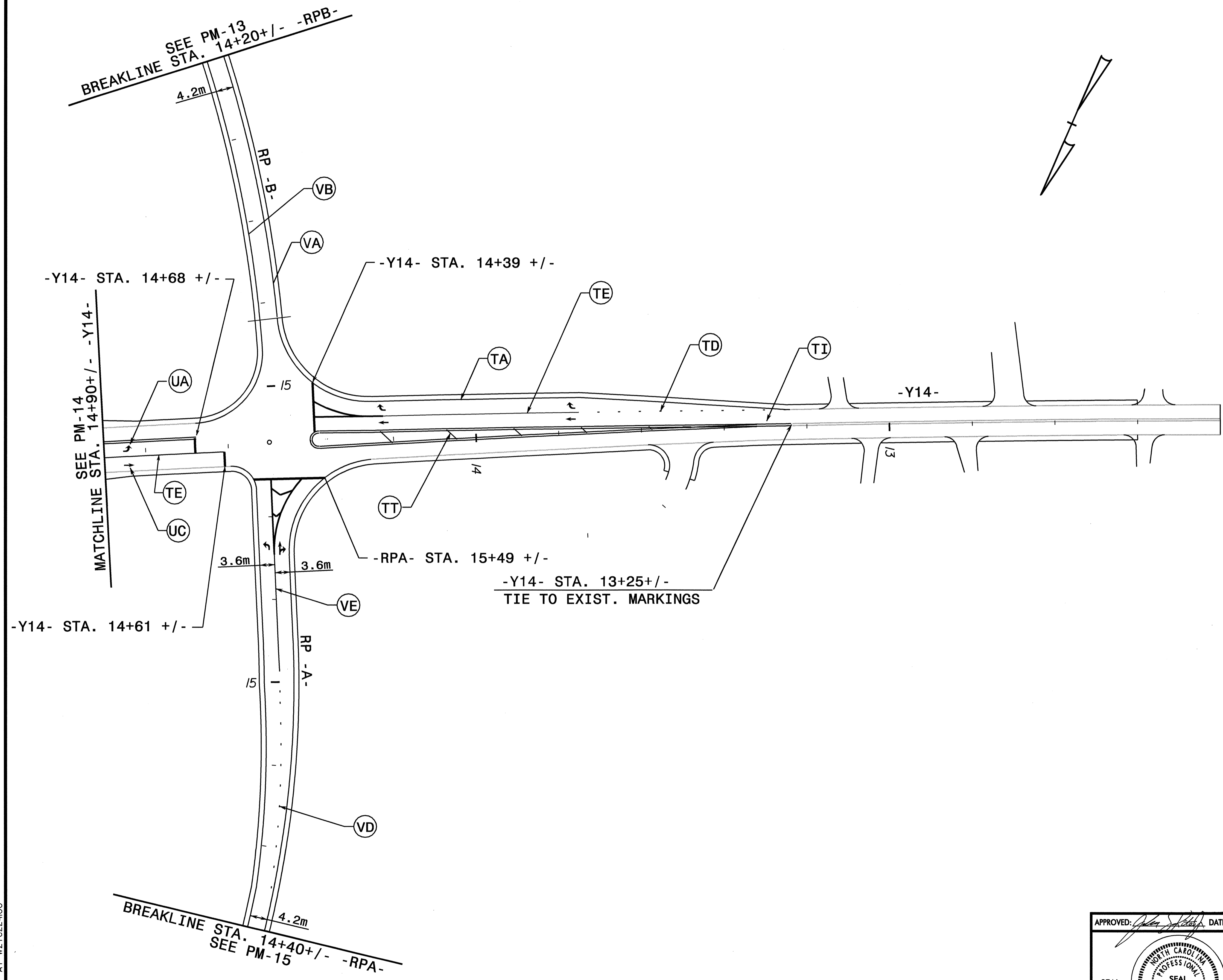

-12

APPROVED: *[Signature]* DATE: 5/16/08

SEAL

FINAL PAVEMENT MARKINGS

SCALE: NONE
 DATE: 11/07
 DWG. BY: DVJ
 DESIGN BY: DVJ
 REVIEWED BY: DAP

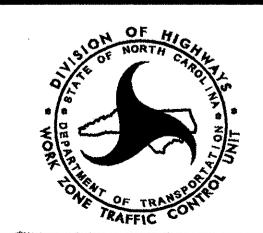

REVISIONS	



SEE PM-15
BREAKLINE STA. 14+20 +/- -RPD-

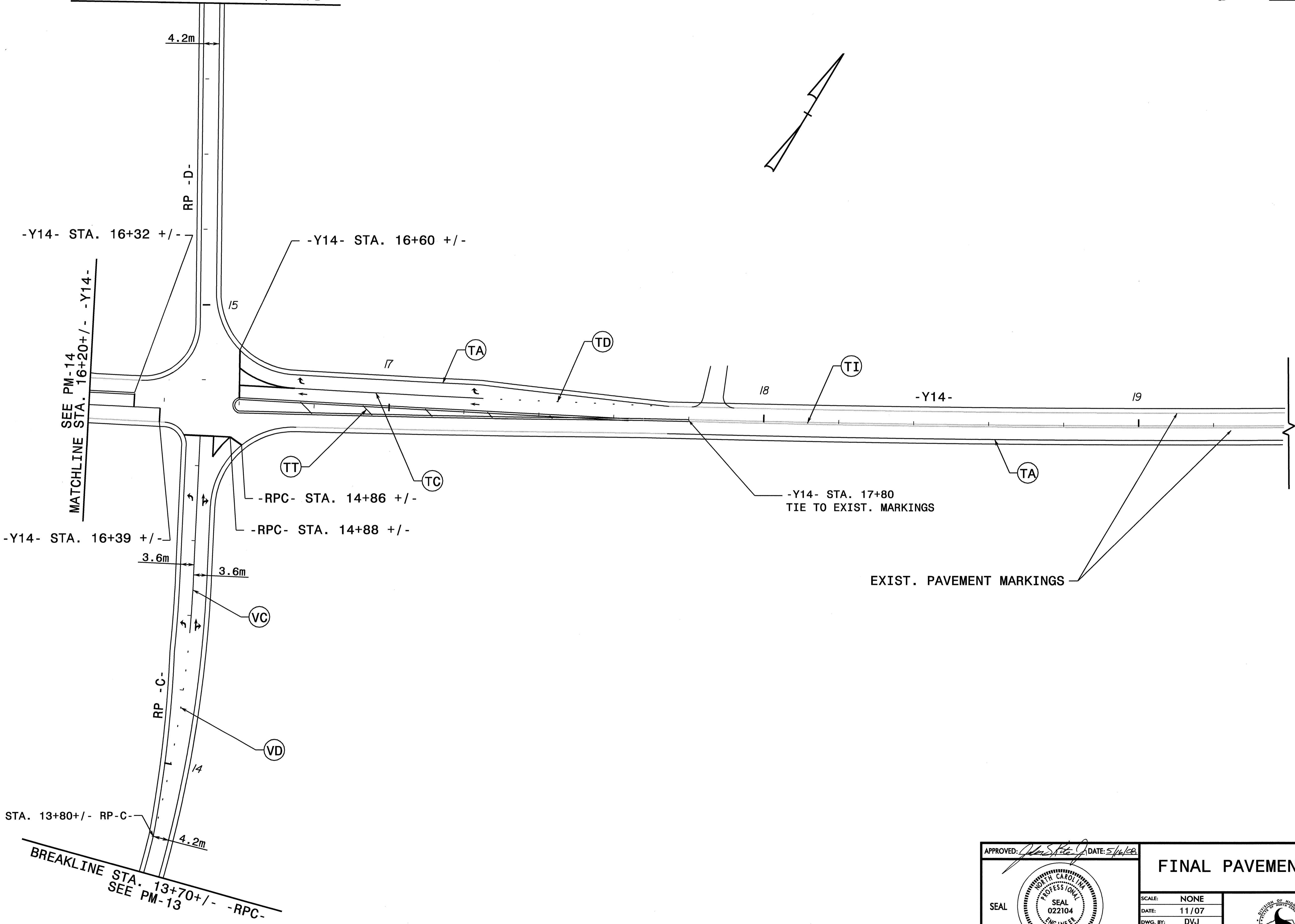

I:\dot\dfs\0910\Pro\N\ip\projects-r\2206bc\traffic\trafficcontrol\top\pavement markings-r-2206bc.tc.24bmp.dgn
 16-MAY-2008 14:25
 daprker AT WZTC224100

APPROVED: *[Signature]* DATE: 5/16/08

SEAL

FINAL PAVEMENT MARKINGS

SCALE:	NONE		REVISIONS
DATE:	11/07		
DWG. BY:	DVJ		
DESIGN BY:	DVJ		
REVIEWED BY:	DAP		



PROJ. REFERENCE NO. R-2206BA & CA	SHEET NO. PM-19
--------------------------------------	--------------------

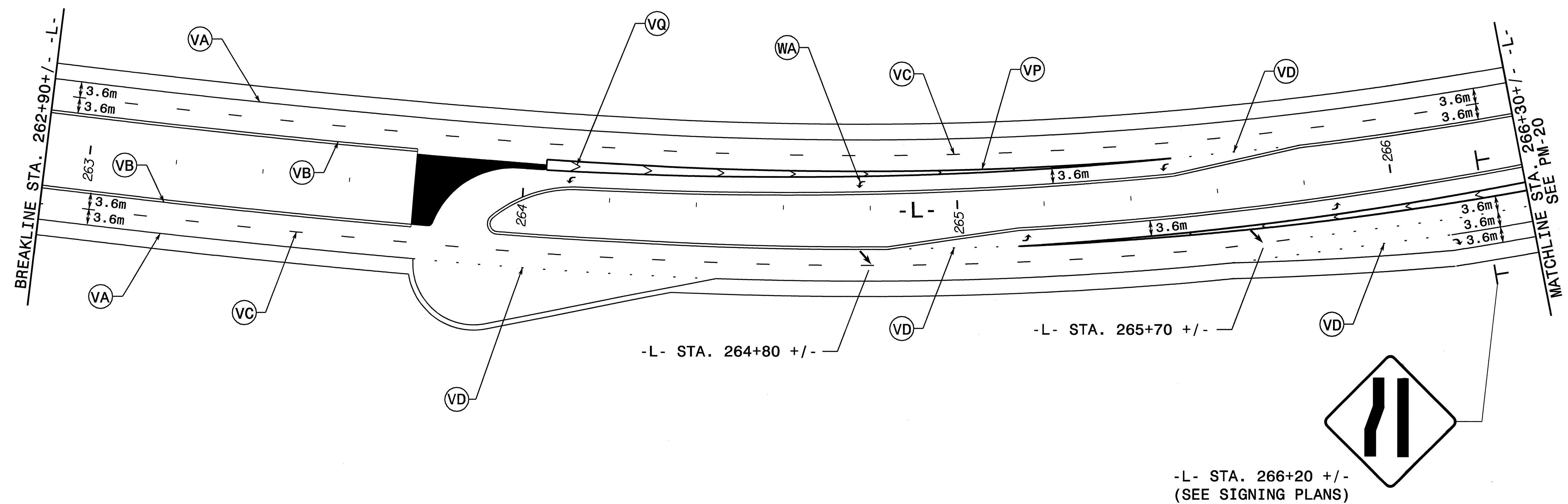
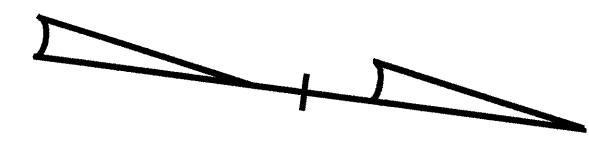

16-MAY-2008 13:15
 \\dot\dferron\10\Projects\16-MAY-2008\Traffic\TrafficControl\Top\pavement markings\2206ba-ca-25pmp.dgn
 daprker AT WZTC224100

APPROVED: <i>John S. Kite</i> DATE: 5/16/08		FINAL PAVEMENT MARKINGS	
SCALE:	NONE		REVISIONS
DATE:	11/07		
DWG. BY:	DVJ		
DESIGN BY:	DVJ		
REVIEWED BY:	DAP		

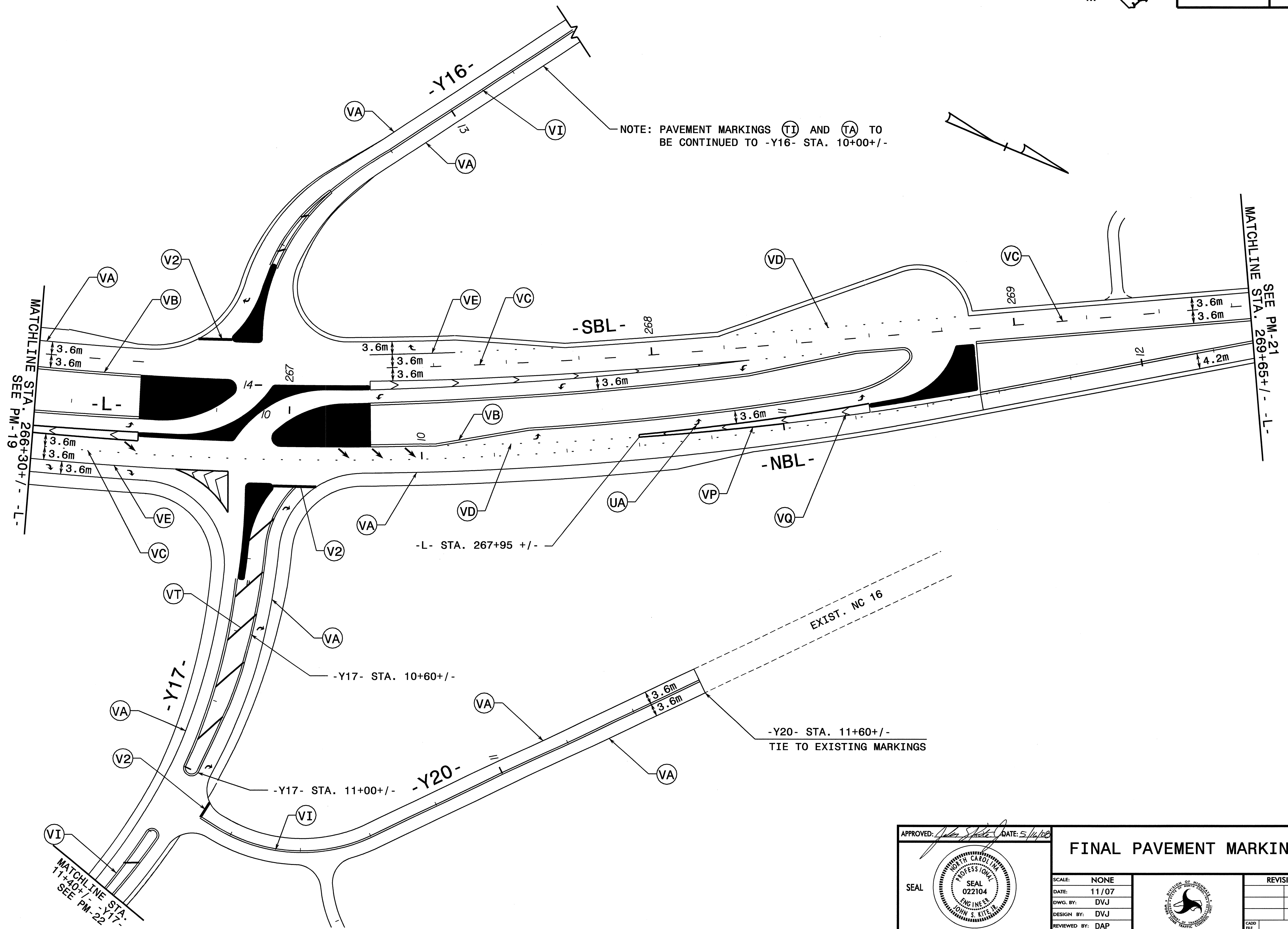

16-MAY-2008 13:48
 \\dot\dfsroot\01\Projects\R-2206ba\traffic\top\pavement markings\R-2206ba.tc.26pmp.dgn
 darpker AT WZTC224100

APPROVED: DATE: 5/11/08		FINAL PAVEMENT MARKINGS	
SCALE:	NONE		REVISIONS
DATE:	11/07		
DWG. BY:	DVJ		
DESIGN BY:	DVJ		
REVIEWED BY:	DAP		CADD FILE



PROJ. REFERENCE NO. R-2206BA & CA	SHEET NO. PM-21
--------------------------------------	--------------------

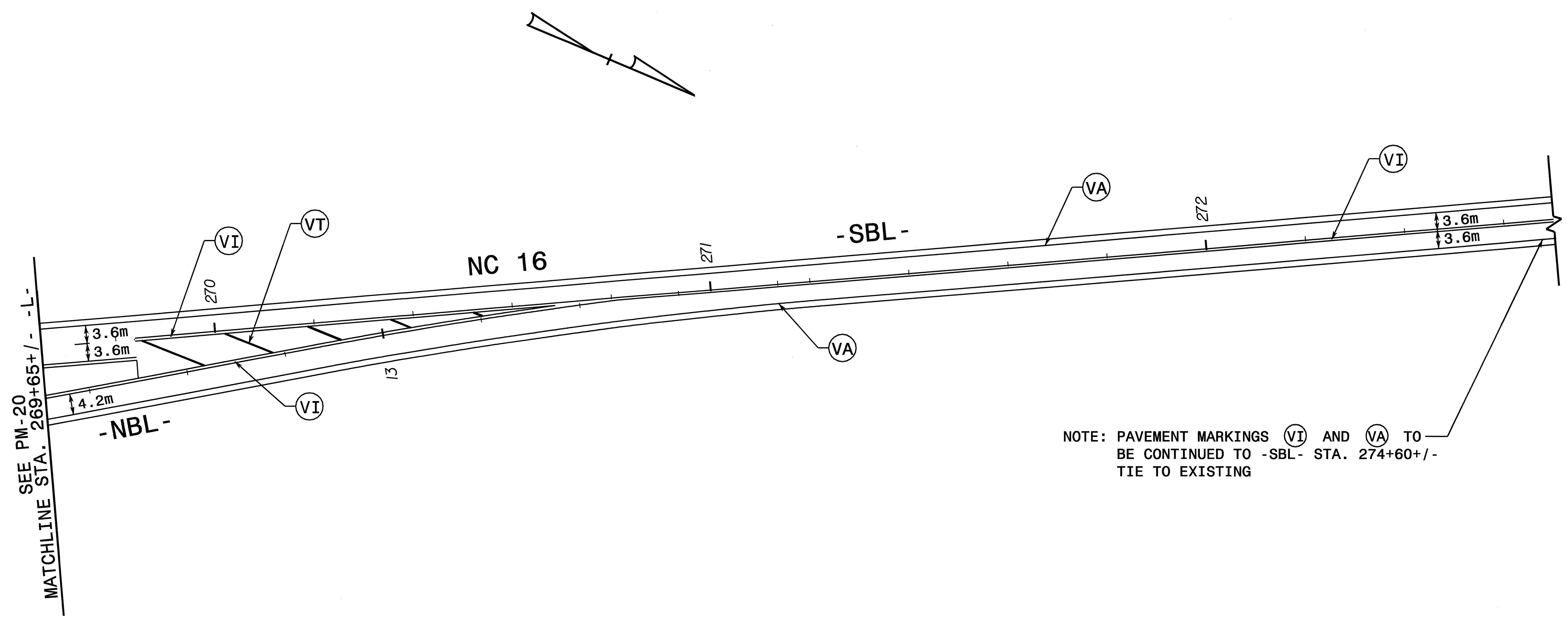

NOTE: PAVEMENT MARKINGS (VI) AND (VA) TO BE CONTINUED TO -SBL- STA. 274+60+/- TIE TO EXISTING

I6-MAY-2008 13:51
 \\Dof\dfsroot\01\Proj\11\proj\projects-r\2206bc\traffic\trafficcontrol\top\pavement markings\2206bc.tc.27bmp.dgn
 cadparker AT WZTC24100

APPROVED: DATE: 5/16/08	FINAL PAVEMENT MARKINGS						
	SCALE: NONE						
	DATE: 11/07						
	DWG. BY: DVJ						
	DESIGN BY: DVJ						
REVIEWED BY: DAP	<table border="1"> <thead> <tr> <th colspan="2">REVISIONS</th> </tr> </thead> <tbody> <tr> <td> </td> <td> </td> </tr> <tr> <td> </td> <td> </td> </tr> </tbody> </table>	REVISIONS					
REVISIONS							
SEAL	CADD FILE						



PROJ. REFERENCE NO.	SHEET NO.
R-2206BA & CA	PM-22

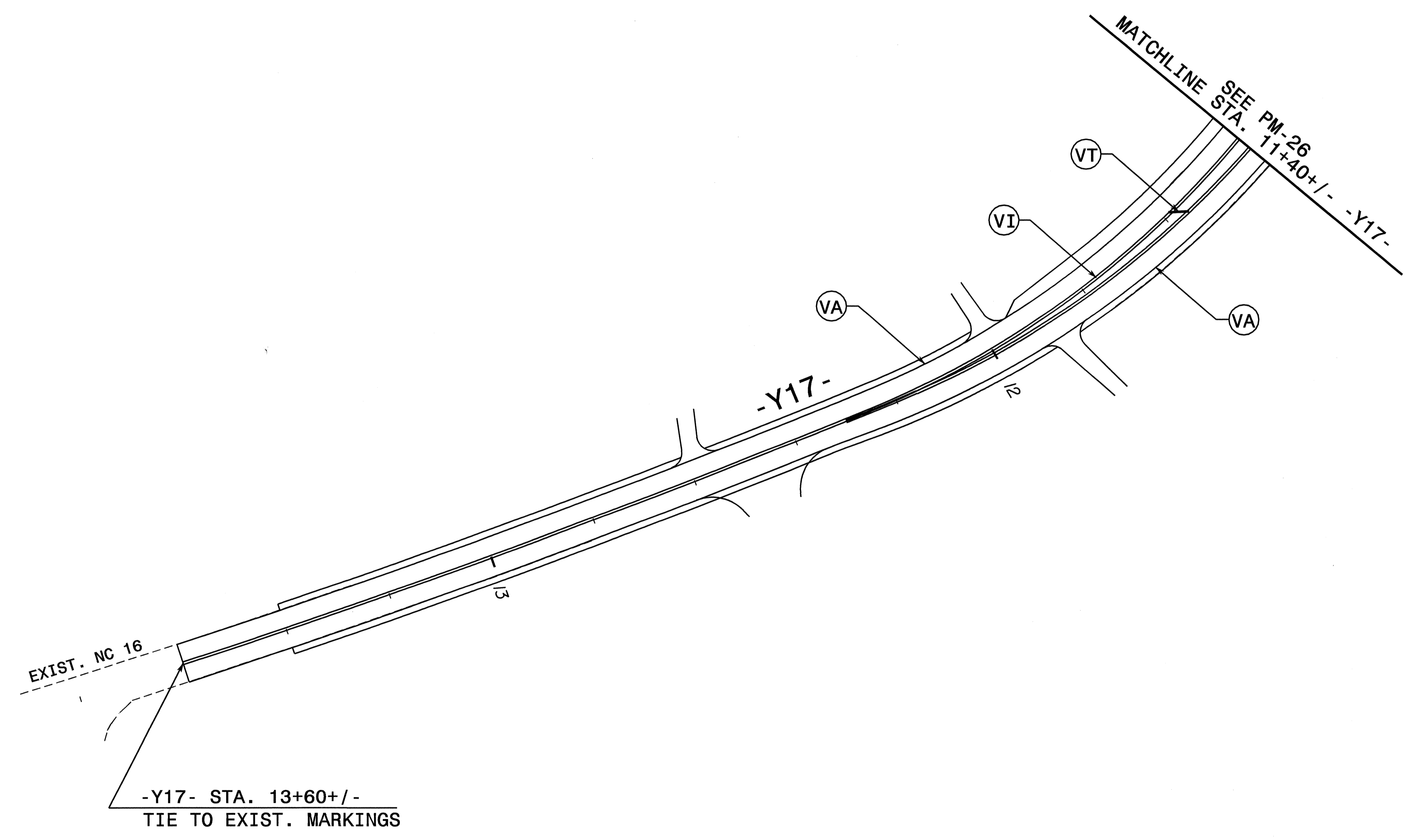
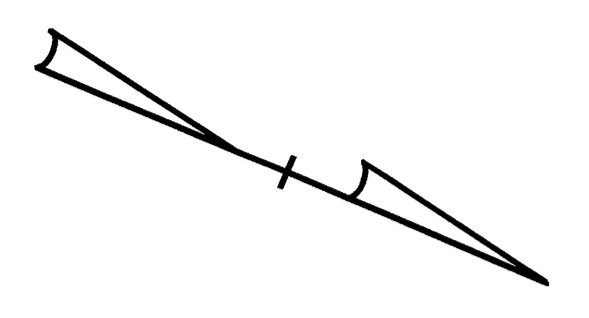

16-MAY-2008 13:59
 \\dot\dfs\o\10\Pro\N\ipp\projects-r\2206ba\traffic\trafficcontrol\top\pavement markings-r-2206ba-fo-29bmp.dgn
 ddparker AT WZTC224100

APPROVED: DATE: 5/16/08		FINAL PAVEMENT MARKINGS		
				SCALE: NONE
		DATE: 11/07		
DWG. BY: DVJ				
DESIGN BY: DVJ				
REVIEWED BY: DAP				