

CONTRACT: C201851 TIP PROJECT: B-4055

See Sheet 1-A For Index of Sheets

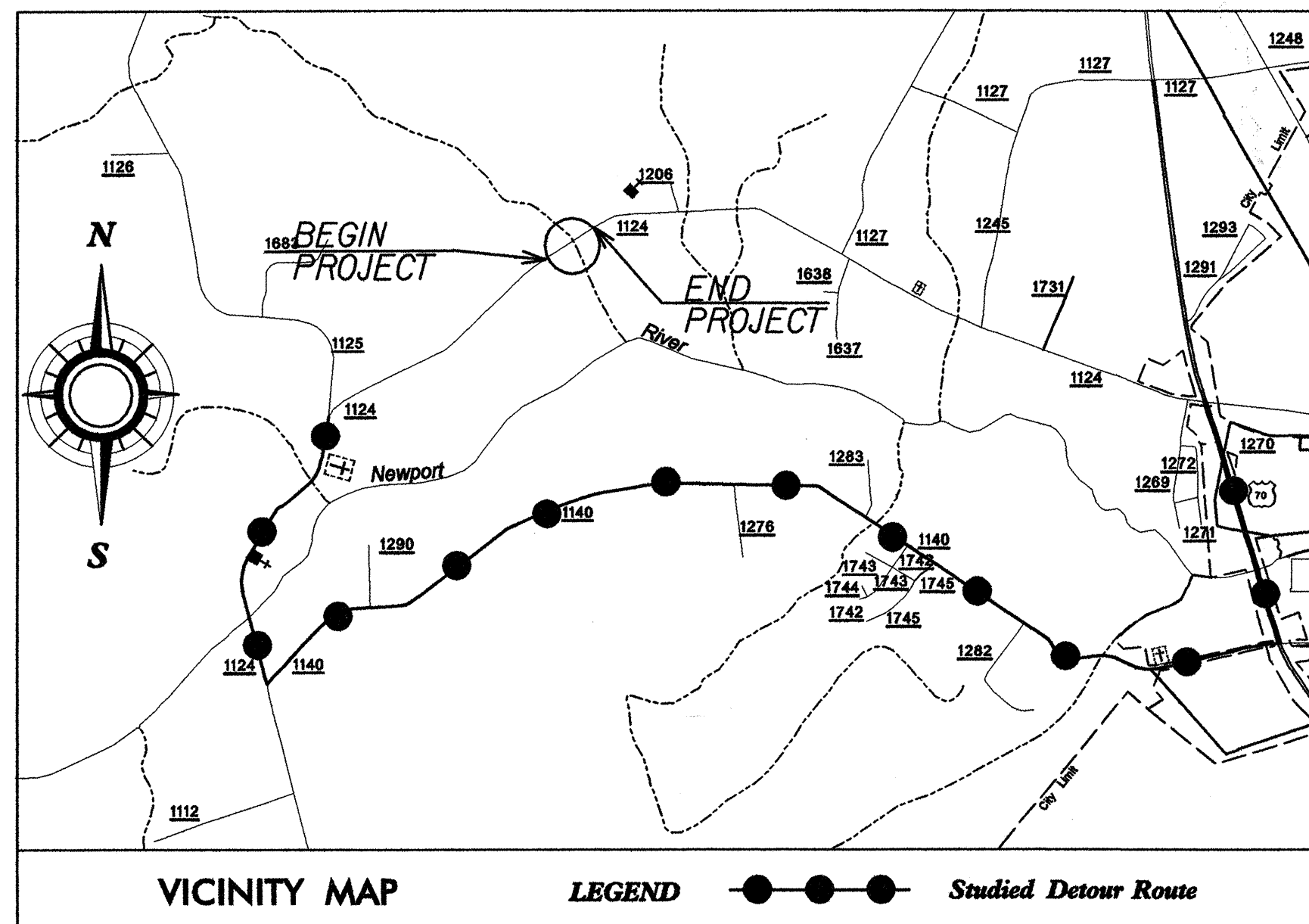

STATE OF NORTH CAROLINA
DIVISION OF HIGHWAYS

CARTERET COUNTY

**LOCATION: BRIDGE NO. 22 OVER BRANCH OF NEWPORT RIVER
ON SR 1124**

TYPE OF WORK: GRADING, DRAINAGE, STRUCTURE, AND PAVING

STATE	STATE PROJECT REFERENCE NO.	SHEET NO.	TOTAL SHEETS
N.C.	B-4055	1	
STATE PROJ. NO.	F.A. PROJ. NO.	DESCRIPTION	
33420.1.1	BRSTP-1124(4)	P.E.	
33420.2.1	BRSTP-1124(4)	RW/UTL.	
33420.3.1	BRSTP-1124(4)	CONST	

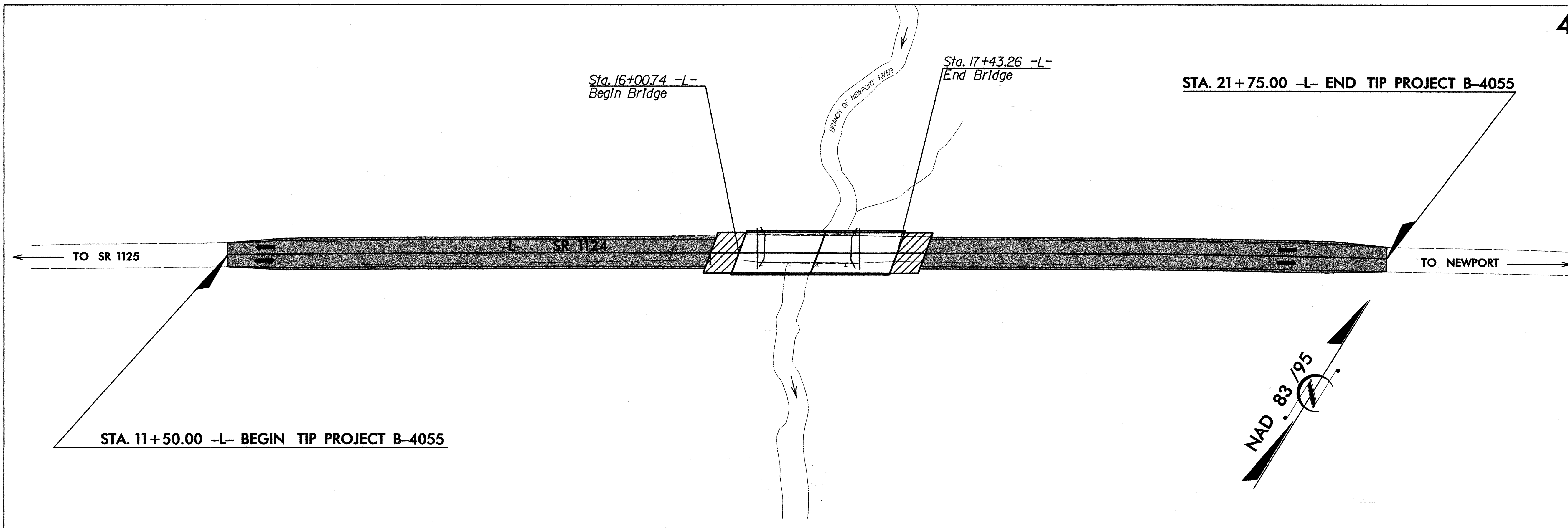

THIS PROJECT IS NOT WITHIN MUNICIPAL BOUNDARIES.

NCDOT CONTACT: CATHY HOUSER, P.E., PROJECT ENGINEER - ROADWAY DESIGN

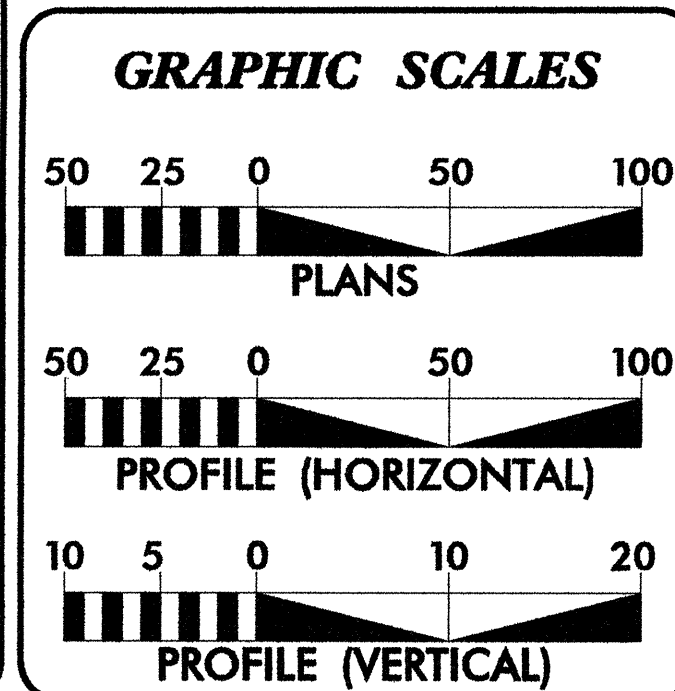

DESIGN DATA

ADT 2008 = 3890
ADT 2030 = 7000
DHV = 10 %
D = 60 %
T = 3 % *
V = 60 MPH
FUNC. CLASS = RURAL MAJOR COLLECTOR
* TTST 1 % DUAL 2 %

PROJECT LENGTH

LENGTH ROADWAY TIP PROJECT B-4055 = 0.167 mi.
LENGTH STRUCTURE TIP PROJECT B-4055 = 0.027 mi.
TOTAL LENGTH TIP PROJECT B-4055 = 0.194 mi.

Prepared in the Office of:
WANG ENGINEERING COMPANY, INC.
CARY, N.C.
FOR NORTH CAROLINA DEPARTMENT OF TRANSPORTATION

2006 STANDARD SPECIFICATIONS

RIGHT OF WAY DATE: July 21, 2006
LETTING DATE: SEPTEMBER 16, 2008

JAMES SJ WANG, P.E.
PROJECT ENGINEER

SCOTT L. KENNEDY
PROJECT DESIGN ENGINEER

HYDRAULICS ENGINEER

SEAL 9334
HENRY WELLS, P.E.

SIGNATURE: [Signature]

ROADWAY DESIGN ENGINEER

SEAL 7921
JAMES S.J. WANG

SIGNATURE: [Signature]

**DIVISION OF HIGHWAYS
STATE OF NORTH CAROLINA**

[Signature]
STATE DESIGN ENGINEER P.E.

DEPARTMENT OF TRANSPORTATION
FEDERAL HIGHWAY ADMINISTRATION

APPROVED DIVISION ADMINISTRATOR DATE

... Verducy VFP13\06051-01-151.dgn 03/07/2008 01:45:53 PM

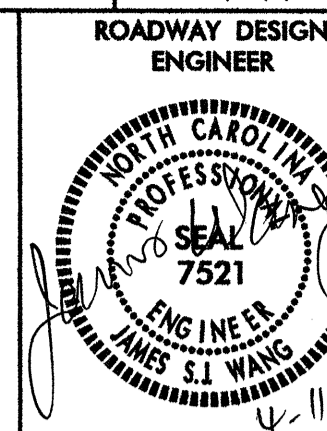

2006 ROADWAY STANDARD DRAWINGS

The following Roadway Standards as appear in "Roadway Standard Drawings" Highway Design Branch - N. C. Department of Transportation - Raleigh, N. C., Dated July 18, 2006 are applicable to this project and by reference hereby are considered a part of these plans:

SHEET NUMBER	INDEX OF SHEETS SHEET
1	TITLE SHEET
1-A	INDEX OF SHEETS, GENERAL NOTES, AND LIST OF STANDARD DRAWINGS
1-B	CONVENTIONAL SYMBOLS
1-C	SURVEY CONTROL SHEET
2	TYPICAL SECTIONS AND PAVEMENT SCHEDULE
2-A	ANCHORAGE FOR FRAMES - BRICK/CONCRETE/PRECAST CONCRETE
3	SUMMARY OF QUANTITIES
3A	SUMMARY OF EARTHWORK SUMMARY OF GUARDRAIL, LIST OF PIPES, ENDWALLS, ETC., AND ASPHALT PAVEMENT REMOVAL SUMMARY
4	PLAN/PROFILE SHEET
TCP-1 THRU TCP-4	TRAFFIC CONTROL PLANS
SD-1	SPECIAL SIGN DESIGN PLANS
EC-1 THRU EC-4	EROSION CONTROL PLANS
U0-1 THRU U0-2	UTILITY BY OTHERS PLANS
X-1	CROSS SECTION INDEX AND SUMMARY SHEET
X-2 THRU X-5	CROSS-SECTIONS
S-1 THRU S-23	STRUCTURE PLANS

STD.NO.	TITLE
DIVISION 2 - EARTHWORK	
200.03	Method of Clearing - Method III
225.02	Guide for Grading Subgrade - Secondary and Local
DIVISION 3 - PIPE CULVERTS	
300.01	Method of Pipe Installation - Method 'A'
DIVISION 4 - MAJOR STRUCTURES	
422.10	Reinforced Bridge Approach Fills
DIVISION 8 - INCIDENTALS	
806.01	Concrete Right of Way Marker
806.02	Granite Right of Way Marker
815.03	Pipe Underdrain and Blind Drain
816.04	Markers for Drainage Structure and Concrete pad
840.00	Concrete Base Pad for Drainage Structures
840.29	Frames and Narrow Slot Flat Grates
840.35	Traffic Bearing Grated Drop Inlet - for Cast Iron Double Frame and Grates
840.46	Traffic Bearing Precast Drainage Structure
840.66	Drainage Structure Steps
846.01	Concrete Curb, Gutter and Curb & Gutter
846.04	Drop Inlet Installation in Shoulder Berm Gutter
862.01	Guardrail Placement
862.02	Guardrail Installation
862.03	Structure Anchor Units
862.04	Anchoring End of Guardrail - for B-77 and B-83 Anchor Units
876.02	Guide for Rip Rap at Pipe Outlets

GENERAL NOTES:

2006 SPECIFICATIONS
EFFECTIVE: 07-18-06
REVISED: 07-18-06

GRADE LINE:

GRADING AND SURFACING:

THE GRADE LINES SHOWN DENOTE THE FINISHED ELEVATION OF THE PROPOSED SURFACING AT GRADE POINTS SHOWN ON THE TYPICAL SECTIONS. GRADE LINES MAY BE ADJUSTED AT THEIR BEGINNING AND ENDING AND AT STRUCTURES AS DIRECTED BY THE ENGINEER IN ORDER TO SECURE A PROPER TIE-IN.

CLEARING:

CLEARING ON THIS PROJECT SHALL BE PERFORMED TO THE LIMITS ESTABLISHED BY METHOD III.

UNDERDRAINS:

UNDERDRAINS SHALL BE CONSTRUCTED IN ACCORDANCE WITH STD. NO. 815.03 AT LOCATIONS DIRECTED BY THE ENGINEER.

GUARDRAIL:

THE GUARDRAIL LOCATIONS SHOWN ON THE PLANS MAY BE ADJUSTED DURING CONSTRUCTION AS DIRECTED BY THE ENGINEER. THE CONTRACTOR SHOULD CONSULT WITH THE ENGINEER PRIOR TO ORDERING GUARDRAIL MATERIAL.

TEMPORARY SHORING:

SHORING REQUIRED FOR THE MAINTENANCE OF TRAFFIC WILL BE PAID FOR AS "EXTRA WORK" IN ACCORDANCE WITH SECTION 104-7.

END BENTS:

THE ENGINEER SHALL CHECK THE STRUCTURE END BENT PLANS, DETAILS, AND CROSS-SECTION PRIOR TO SETTING OF THE SLOPE STAKES FOR THE EMBANKMENT OR EXCAVATION APPROACHING A BRIDGE.

UTILITIES:

UTILITY OWNERS ON THIS PROJECT ARE

EMBARQ - TELEPHONE

TIME WARNER

ANY RELOCATION OF EXISTING UTILITIES WILL BE ACCOMPLISHED BY OTHERS.

RIGHT-OF-WAY MARKERS:

ALL RIGHT-OF-WAY MARKERS ON THIS PROJECT SHALL BE PLACED BY CONTRACT.













Note: Not to Scale

*S.U.E. = Subsurface Utility Engineering











STATE OF NORTH CAROLINA
DIVISION OF HIGHWAYS

CONVENTIONAL PLAN SHEET SYMBOLS











BOUNDARIES AND PROPERTY:

State Line	_____
County Line	_____
Township Line	_____
City Line	_____
Reservation Line	_____
Property Line	_____
Existing Iron Pin	_____ 
Property Corner	_____ 
Property Monument	_____ 
Parcel/Sequence Number	_____ 
Existing Fence Line	_____ 
Proposed Woven Wire Fence	_____ 
Proposed Chain Link Fence	_____ 
Proposed Barbed Wire Fence	_____ 
Existing Wetland Boundary	_____ 
Proposed Wetland Boundary	_____ 
Existing Endangered Animal Boundary	_____ 
Existing Endangered Plant Boundary	_____ 





BUILDINGS AND OTHER CULTURE:

Gas Pump Vent or U/G Tank Cap	_____ 
Sign	_____ 
Well	_____ 
Small Mine	_____ 
Foundation	_____ 
Area Outline	_____ 
Cemetery	_____ 
Building	_____ 
School	_____ 
Church	_____ 
Dam	_____ 



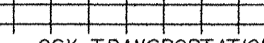
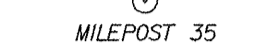









HYDROLOGY:

Stream or Body of Water	_____
Hydro, Pool or Reservoir	_____ 
Jurisdictional Stream	_____ 
Buffer Zone 1	_____ 
Buffer Zone 2	_____ 
Flow Arrow	_____ 
Disappearing Stream	_____ 
Spring	_____ 
Wetland	_____ 
Proposed Lateral, Tail, Head Ditch	_____ 
False Sump	_____ 





RAILROADS:







Standard Gauge	_____ 
RR Signal Milepost	_____ 
Switch	_____ 
RR Abandoned	_____ 
RR Dismantled	_____ 

RIGHT OF WAY:







Baseline Control Point	_____ 
Existing Right of Way Marker	_____ 
Existing Right of Way Line	_____ 
Proposed Right of Way Line	_____ 
Proposed Right of Way Line with Iron Pin and Cap Marker	_____ 
Proposed Right of Way Line with Concrete or Granite Marker	_____ 
Existing Control of Access	_____ 
Proposed Control of Access	_____ 
Existing Easement Line	_____ 
Proposed Temporary Construction Easement	_____ 
Proposed Temporary Drainage Easement	_____ 
Proposed Permanent Drainage Easement	_____ 
Proposed Permanent Utility Easement	_____ 

ROADS AND RELATED FEATURES:







Existing Edge of Pavement	_____
Existing Curb	_____
Proposed Slope Stakes Cut	_____ 
Proposed Slope Stakes Fill	_____ 
Proposed Wheel Chair Ramp	_____ 
Proposed Wheel Chair Ramp Curb Cut	_____ 
Curb Cut for Future Wheel Chair Ramp	_____ 

Existing Metal Guardrail	_____ 
Proposed Guardrail	_____ 
Existing Cable Guiderail	_____ 
Proposed Cable Guiderail	_____ 
Equality Symbol	_____ 
Pavement Removal	_____ 

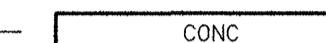
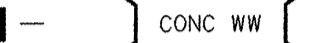
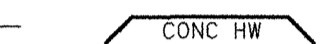

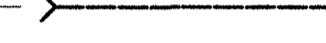







VEGETATION:

Single Tree	_____ 
Single Shrub	_____ 
Hedge	_____ 
Woods Line	_____ 
Orchard	_____ 
Vineyard	_____ 













EXISTING STRUCTURES:

MAJOR:	
Bridge, Tunnel or Box Culvert	_____ 
Bridge Wing Wall, Head Wall and End Wall	_____ 
MINOR:	
Head and End Wall	_____ 
Pipe Culvert	_____ 
Footbridge	_____ 
Drainage Box: Catch Basin, DI or JB	_____ 
Paved Ditch Gutter	_____ 
Storm Sewer Manhole	_____ 
Storm Sewer	_____ 







UTILITIES:

POWER:	
Existing Power Pole	_____ 
Proposed Power Pole	_____ 
Existing Joint Use Pole	_____ 
Proposed Joint Use Pole	_____ 
Power Manhole	_____ 
Power Line Tower	_____ 
Power Transformer	_____ 
U/G Power Cable Hand Hole	_____ 
H-Frame Pole	_____ 
Recorded U/G Power Line	_____ 
Designated U/G Power Line (S.U.E.*)	_____ 









TELEPHONE:

Existing Telephone Pole	_____ 
Proposed Telephone Pole	_____ 
Telephone Manhole	_____ 
Telephone Booth	_____ 
Telephone Pedestal	_____ 
Telephone Cell Tower	_____ 
U/G Telephone Cable Hand Hole	_____ 
Recorded U/G Telephone Cable	_____ 
Designated U/G Telephone Cable (S.U.E.*)	_____ 
Recorded U/G Telephone Conduit	_____ 
Designated U/G Telephone Conduit (S.U.E.*)	_____ 
Recorded U/G Fiber Optics Cable	_____ 
Designated U/G Fiber Optics Cable (S.U.E.*)	_____ 





WATER:

Water Manhole	_____ 
Water Meter	_____ 
Water Valve	_____ 
Water Hydrant	_____ 
Recorded U/G Water Line	_____ 
Designated U/G Water Line (S.U.E.*)	_____ 
Above Ground Water Line	_____ 







TV:

TV Satellite Dish	_____ 
TV Pedestal	_____ 
TV Tower	_____ 
U/G TV Cable Hand Hole	_____ 
Recorded U/G TV Cable	_____ 
Designated U/G TV Cable (S.U.E.*)	_____ 
Recorded U/G Fiber Optic Cable	_____ 
Designated U/G Fiber Optic Cable (S.U.E.*)	_____ 











GAS:

Gas Valve	_____ 
Gas Meter	_____ 
Recorded U/G Gas Line	_____ 
Designated U/G Gas Line (S.U.E.*)	_____ 
Above Ground Gas Line	_____ 

SANITARY SEWER:

Sanitary Sewer Manhole	_____ 
Sanitary Sewer Cleanout	_____ 
U/G Sanitary Sewer Line	_____ 
Above Ground Sanitary Sewer	_____ 
Recorded SS Forced Main Line	_____ 
Designated SS Forced Main Line (S.U.E.*)	_____ 

MISCELLANEOUS:

Utility Pole	_____ 
Utility Pole with Base	_____ 
Utility Located Object	_____ 
Utility Traffic Signal Box	_____ 
Utility Unknown U/G Line	_____ 
U/G Tank; Water, Gas, Oil	_____ 
A/G Tank; Water, Gas, Oil	_____ 
U/G Test Hole (S.U.E.*)	_____ 
Abandoned According to Utility Records	_____ 
End of Information	_____ 

SURVEY CONTROL SHEET B-4055

PROJECT REFERENCE NO.	SHEET NO.
B-4055	1-C
Location and Surveys	

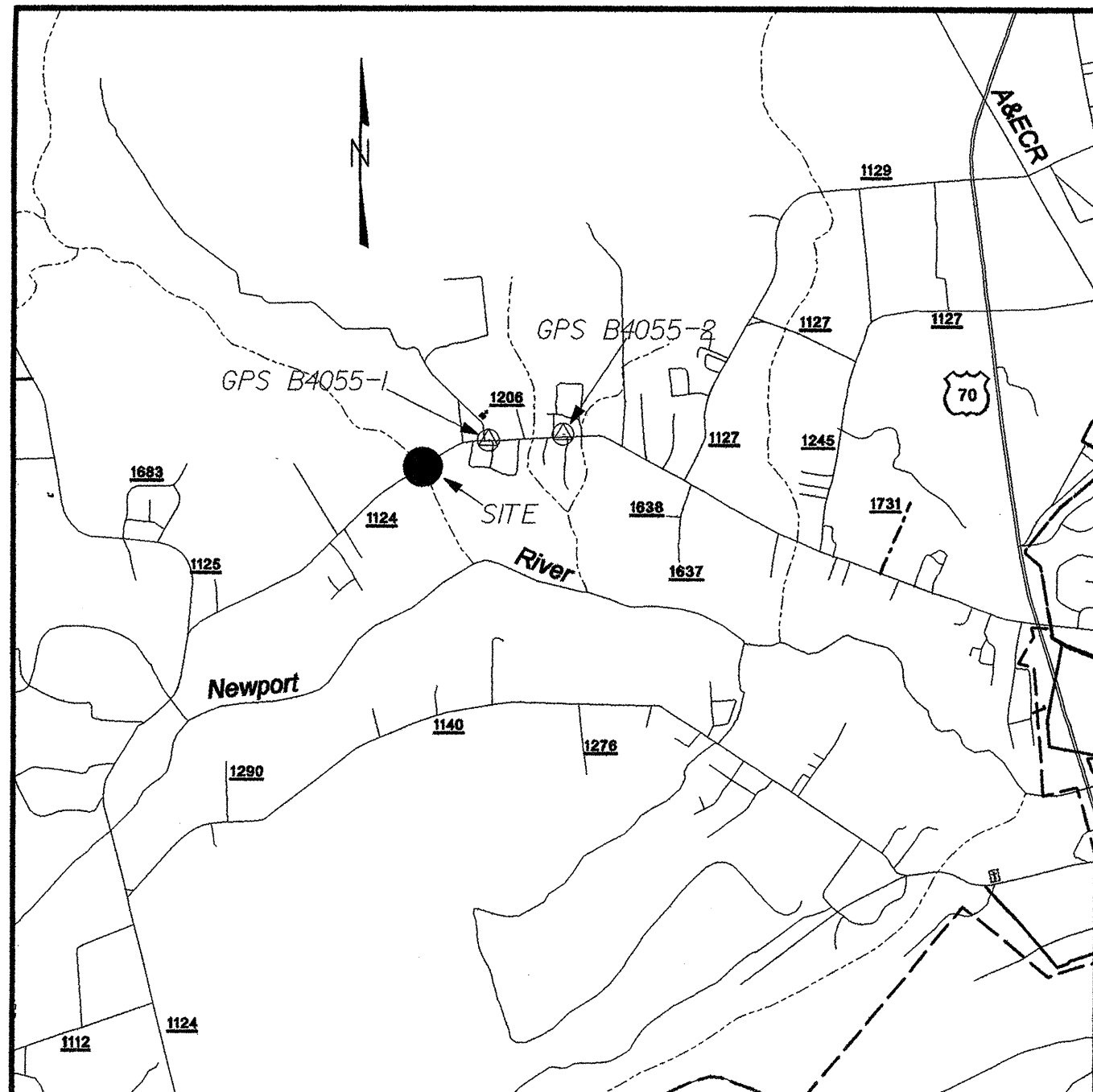

VICINITY MAP

BL POINT	DESC.	NORTH	EAST	ELEVATION	L STATION	OFFSET
1	BL-1	387555.1670	2625664.2990	16.50	10+01.77	24.33 LT
2	BL-2	387844.8470	2626202.0320	12.14	16+11.36	14.51 RT
3	BL-3	388195.2810	2626787.7620	12.69	22+94.30	16.08 RT

 BM1 ELEVATION = 9.37
 N 388027 E 2626236
 L STATION 17+36 123 LEFT
 RR SPIKE IN 30" PINE

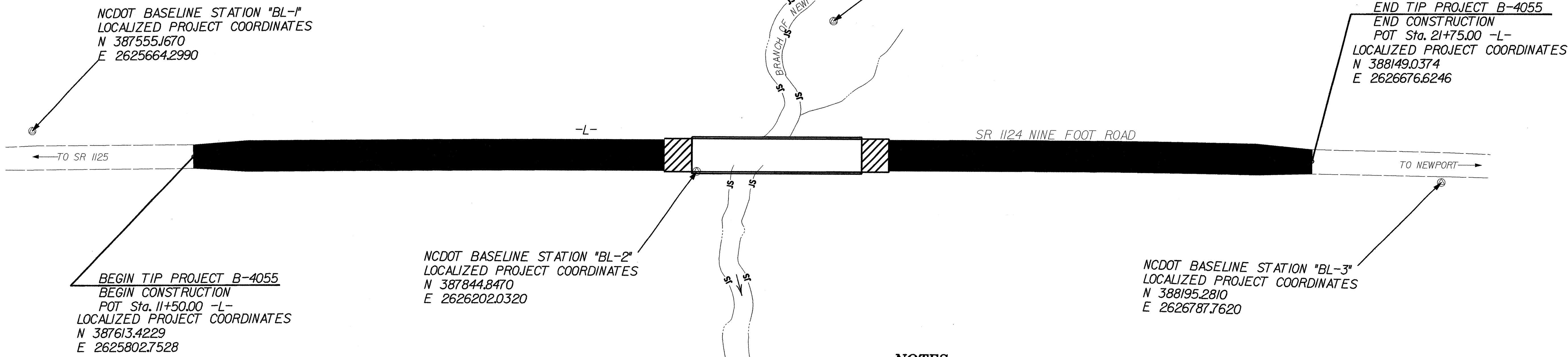
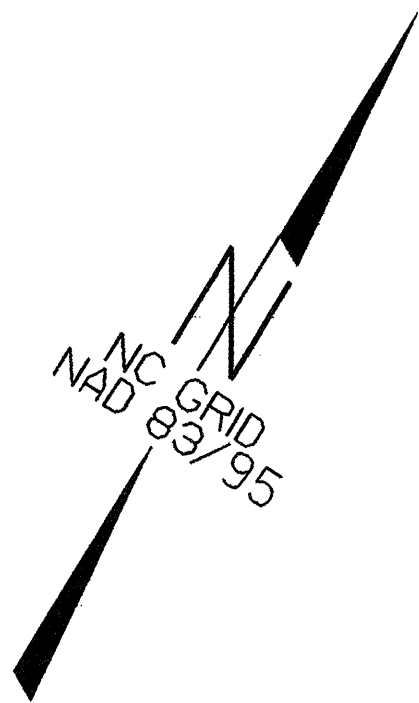

DATUM DESCRIPTION
 THE LOCALIZED COORDINATE SYSTEM DEVELOPED FOR THIS PROJECT IS BASED ON THE STATE PLANE COORDINATES ESTABLISHED BY NCDOT FOR MONUMENT "GPS B4055-1"
 WITH NAD 1983/95 STATE PLANE GRID COORDINATES OF
 NORTHING: 388440.9820(±) EASTING: 2627545.4270(±)
 THE AVERAGE COMBINED GRID FACTOR USED ON THIS PROJECT (GROUND TO GRID) IS: 0.99990296
 THE N.C. LAMBERT GRID BEARING AND LOCALIZED HORIZONTAL GROUND DISTANCE FROM "GPS B4055-1" TO -L- STATION 11+50.00 IS
 S 64°35'52.6" W 1929.1883 (±)
 ALL LINEAR DIMENSIONS ARE LOCALIZED HORIZONTAL DISTANCES
 VERTICAL DATUM USED IS NAVD 88

- NOTES:**
1. THE CONTROL DATA FOR THIS PROJECT CAN BE FOUND ELECTRONICALLY BY SELECTING PROJECT CONTROL DATA AT:
[HTTP://WWW.DOH.DOT.STATE.NC.US/PRECONSTRUCT/HIGHWAY/LOCATION/PROJECT/](http://www.doh.dot.state.nc.us/preconstruct/highway/location/project/)
 THE FILES TO BE FOUND ARE AS FOLLOWS:
 b4055_ls_control_050531.txt
 SITE CALIBRATION INFORMATION HAS NOT BEEN PROVIDED FOR THIS PROJECT. IF FURTHER INFORMATION IS NEEDED, PLEASE CONTACT THE LOCATION AND SURVEYS UNIT.
 - ⊙ INDICATES GEODETIC CONTROL MONUMENTS USED OR SET FOR HORIZONTAL PROJECT CONTROL BY THE NCDOT LOCATION AND SURVEYS UNIT.
 PROJECT CONTROL ESTABLISHED USING GLOBAL POSITIONING SYSTEM.
 NETWORK ESTABLISHED FROM NGS ONLINE POSITIONING SERVICE (OPUS)
 SEE GPS CALIBRATION SHEET FOR HORIZONTAL AND VERTICAL COORDINATE VALUES.

NOTE: DRAWING NOT TO SCALE

Highway Project Location - 02/19/2008 03:35:49 PM

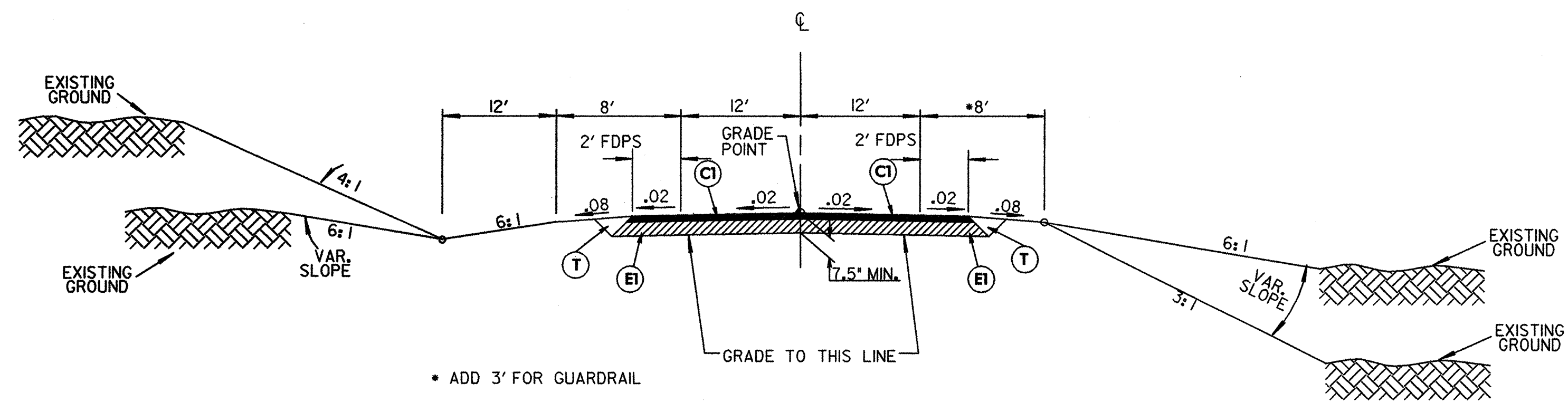

TYPICAL SECTION NO. 1
 USE TYPICAL SECTION NO. 1 AS FOLLOWS
 -L- Sta. 11+50.00 to Sta. 16+00.74 (BEGIN BRIDGE)
 -L- Sta. 17+43.26 (END BRIDGE) to Sta. 21+75.00

PAVEMENT SCHEDULE	
A1	PROP. 5" PORTLAND CEMENT CONCRETE PAVEMENT
C1	PROP. APPROX. 2.5" ASPHALT CONC. SURFACE COURSE, TYPE SF9.5A, AT AN AVERAGE RATE OF 137.5 LBS PER SQ. YD. IN EACH OF TWO LAYERS.
E1	PROP. APPROX. 5" ASPHALT CONC. BASE COURSE, TYPE B25.0B, AT AN AVERAGE RATE OF 570 LBS PER SQ. YD.
T	EARTH MATERIAL

NOTE: ALL SLOPES 1:1 UNLESS OTHERWISE SPECIFIED

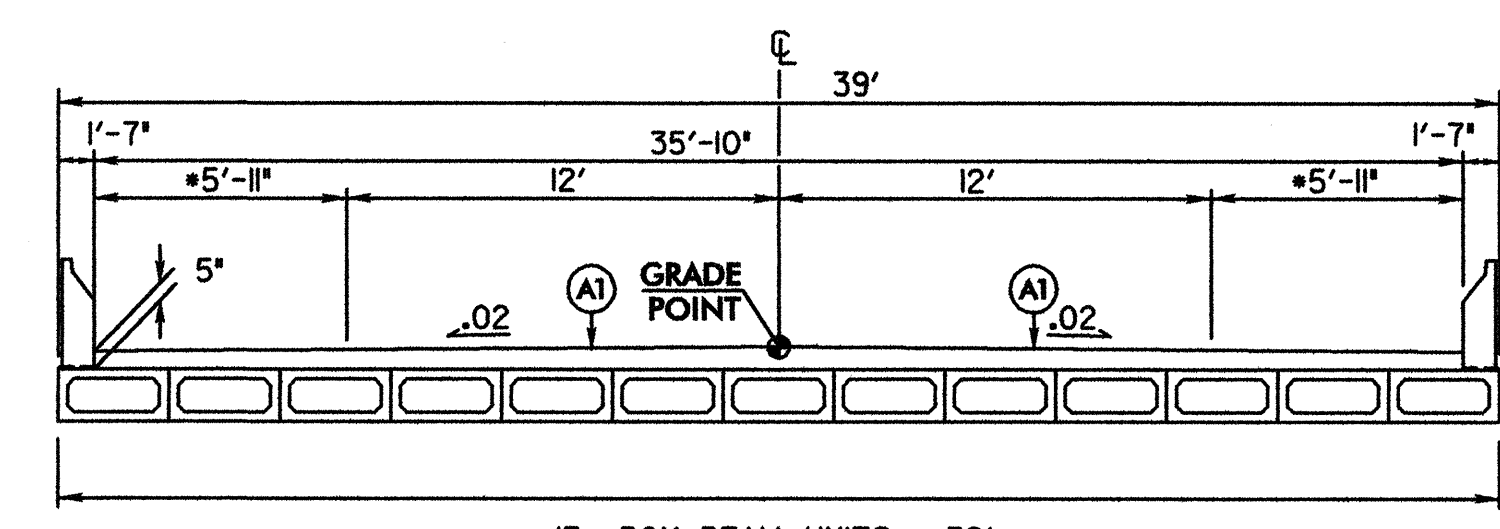

TYPICAL BRIDGE SECTION
 -L- Sta. 16+00.74 to Sta. 17+43.26

•ADDITIONAL WIDTH NEEDED DUE TO SPREAD

STATE OF NORTH CAROLINA
DEPT. OF TRANSPORTATION
DIVISION OF HIGHWAYS
RALEIGH, N.C.

ENGLISH DETAIL DRAWING FOR
ANCHORAGE FOR FRAMES
BRICK/CONCRETE/PRECAST CONCRETE

SHEET 1 OF 1
840D25

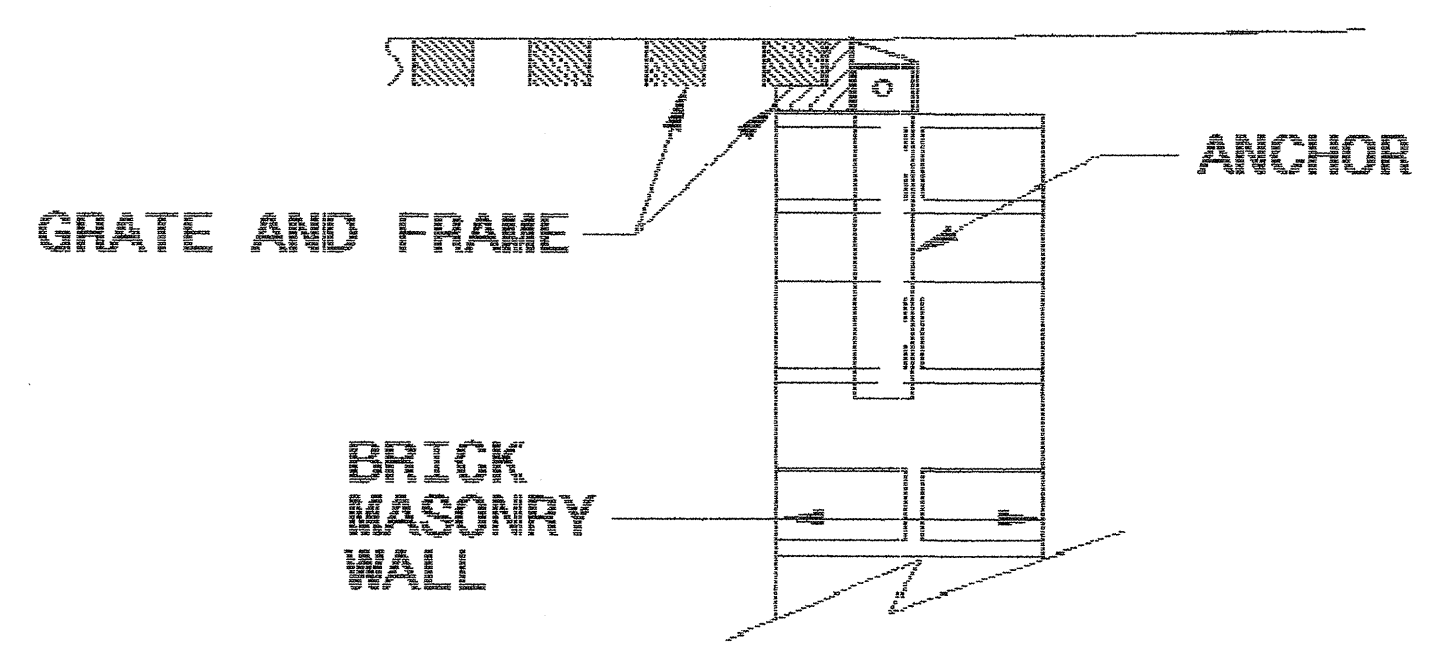

BRICK MASONRY CONSTRUCTION

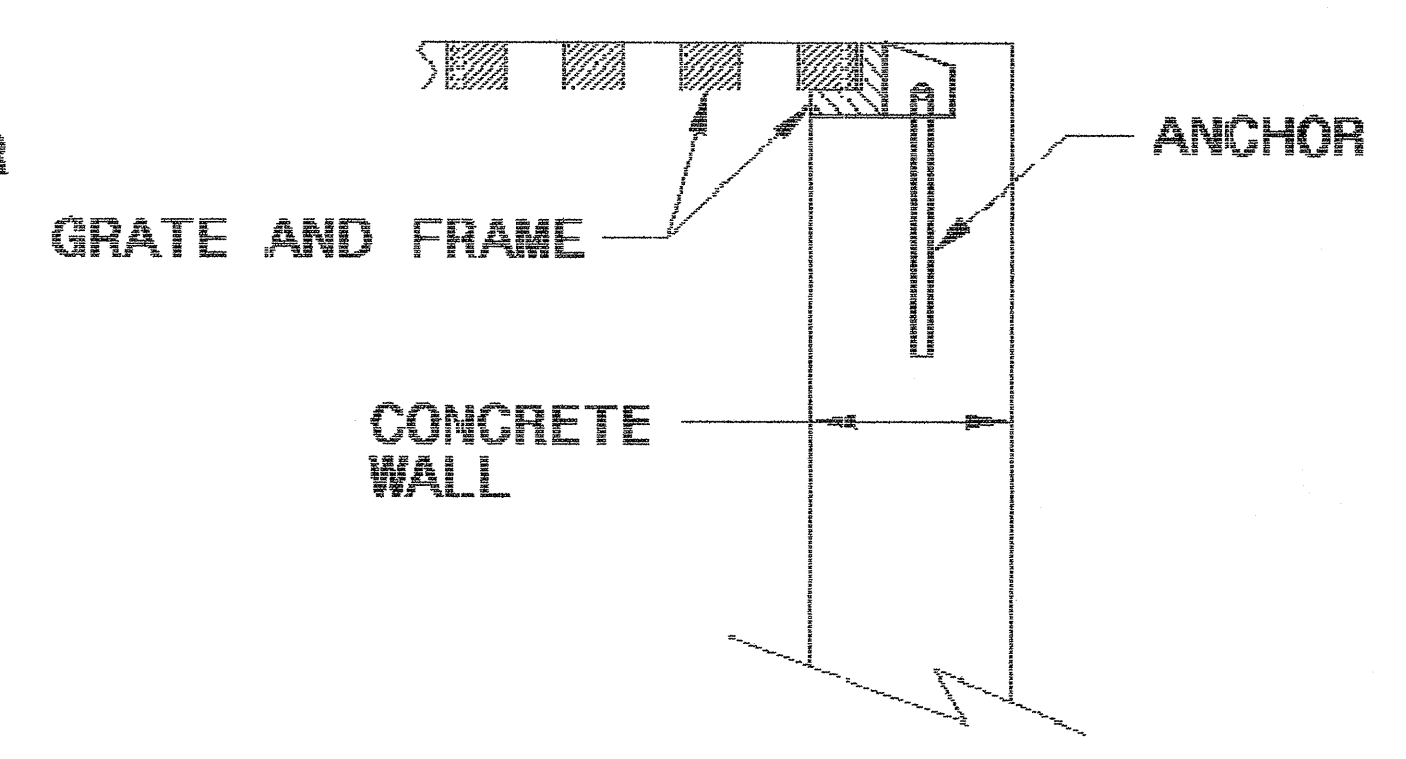

CONCRETE CONSTRUCTION

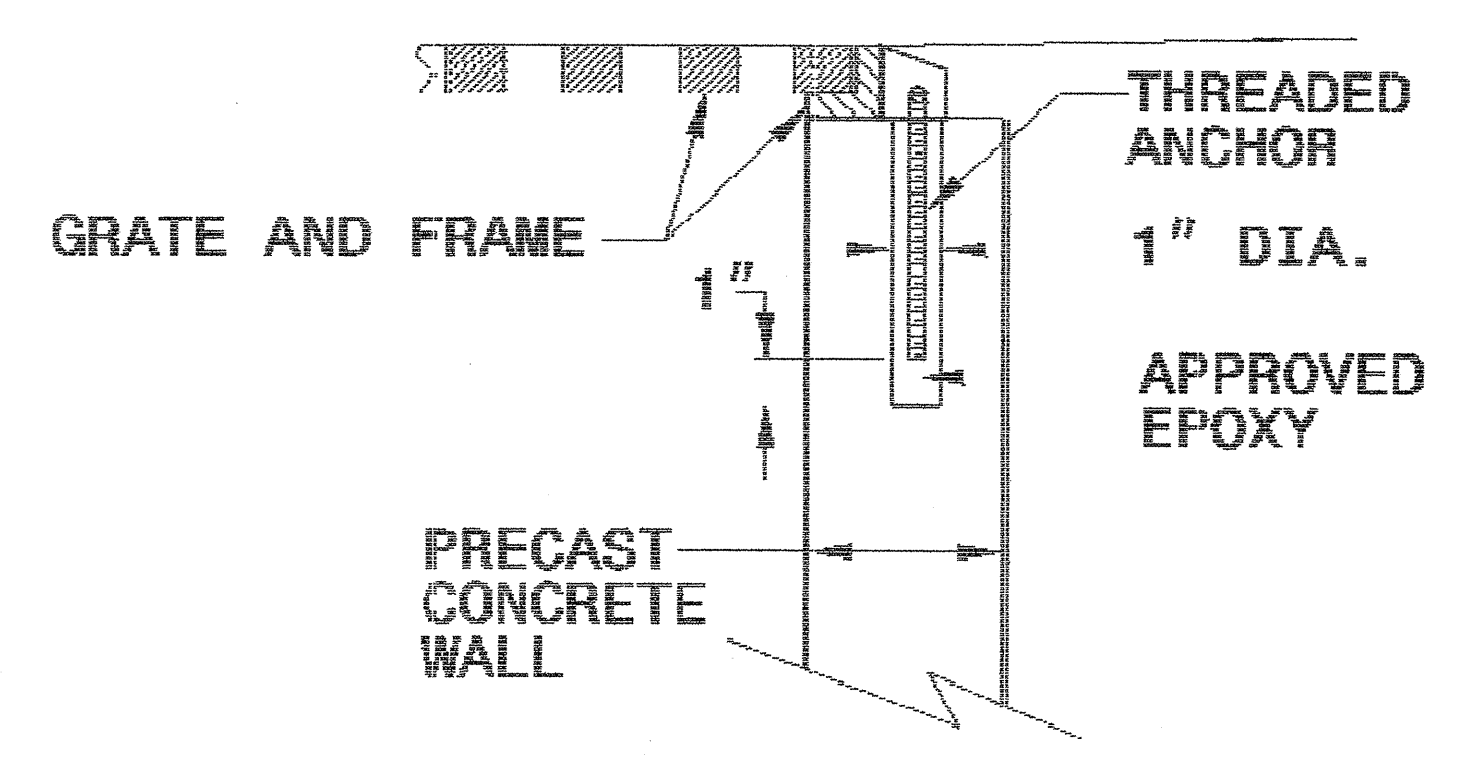

PRECAST CONCRETE CONSTRUCTION

DETAIL SHOWING ANCHORAGE OF FRAME FOR GRATED DROP INLET

NOTE:
CONSTRUCT GRATED DROP INLET TO COINCIDE WITH NORMAL OR SUPERELEVATED SHOULDER OR PAVEMENT SLOPE.

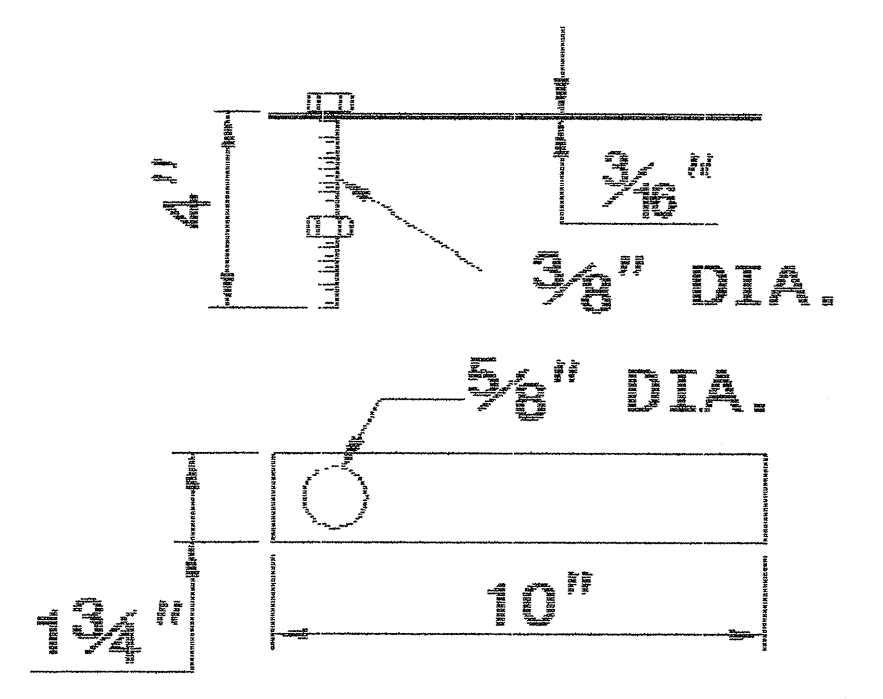

MASONRY ANCHOR
3/8" DIA. BOLT WITH PLATE

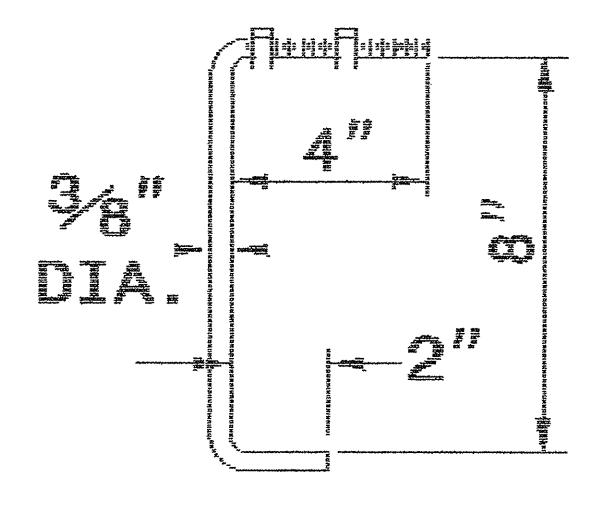

CONCRETE ANCHOR
3/8" DIA. BENT BAR

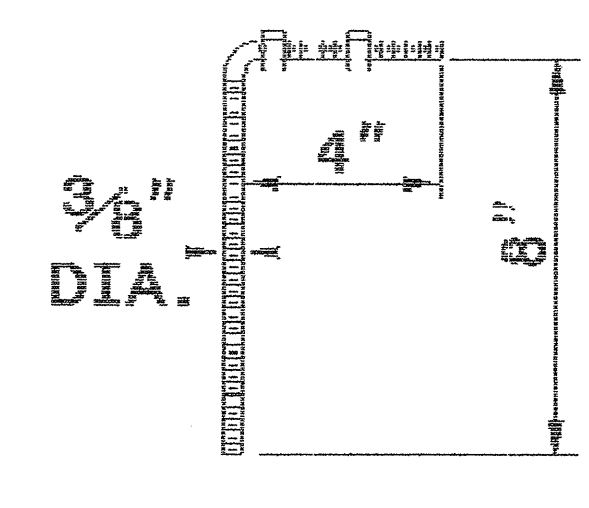

PRECAST CONCRETE ANCHOR
3/8" DIA. BENT BAR

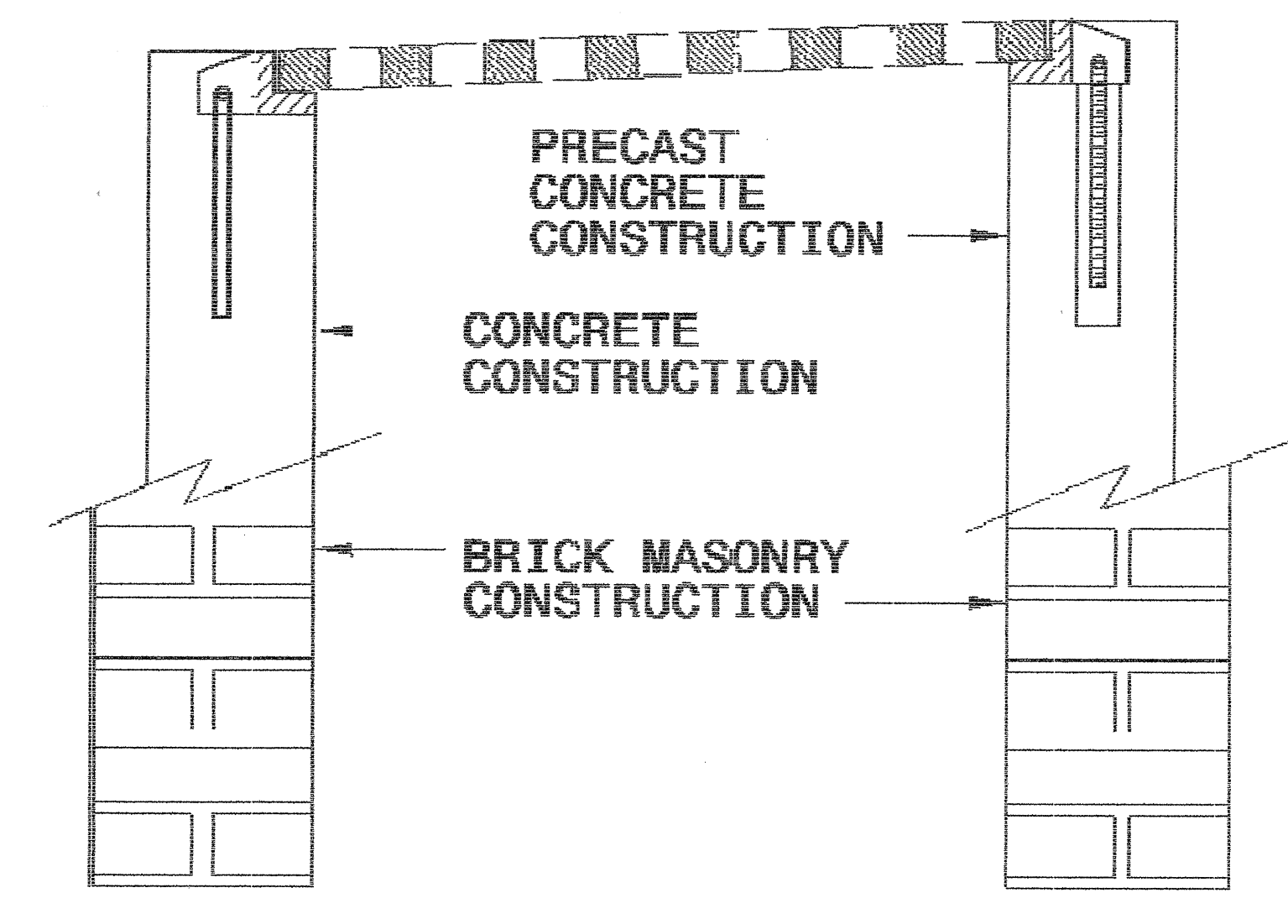

FRAME AND GRATE INSTALLATION FOR NORMAL CROWN AND SUPERELEVATED SECTIONS

STATE OF NORTH CAROLINA
DEPT. OF TRANSPORTATION
DIVISION OF HIGHWAYS
RALEIGH, N.C.

ENGLISH DETAIL DRAWING FOR
ANCHORAGE FOR FRAMES
BRICK/CONCRETE/PRECAST CONCRETE

SHEET 1 OF 1
840D25

27-SE-2006-08-09
C:\ncs\projects\840D25\Special Detail\Anchor\Drawings\840D25 Anchor.dwg
Special Detail\Anchor\Drawings\840D25 Anchor.dwg for Frames\840D25.dwg

PROJECT SERVICES UNIT
STANDARDS AND SPECIAL DESIGN
Office 919-250-4128 FAX 919-250-4119

SEE PLATE FOR TITLE

ORIGINAL BY: 2006 STD 840-25 DATE: 07/18/06
MODIFIED BY: E.E. WARD DATE: 9/25/06
CHECKED BY: _____ DATE: _____
FILE SPEC.: _____

P:\840D25_007_SHP12-1.dwg 02/14/2008 08:51:22 AM

-L-
 PI Sta 20+10.51
 $\Delta = 1'17" 21.2" (RT)$
 $D = 0' 34" 22.6"$
 $L = 225.01'$
 $T = 112.51'$
 $R = 10,000.00'$
 $SE = NC$
 $DS = 60mph$

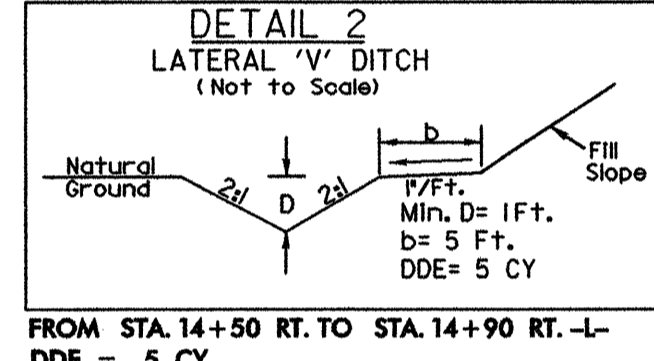
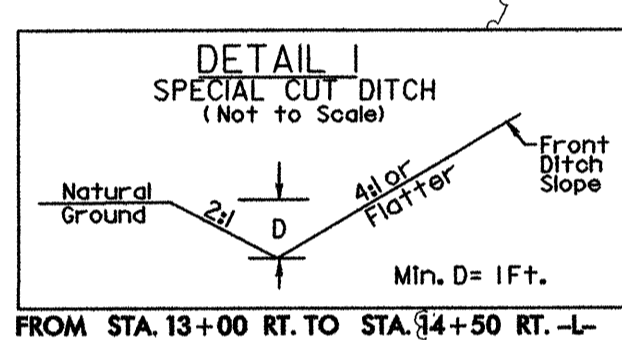
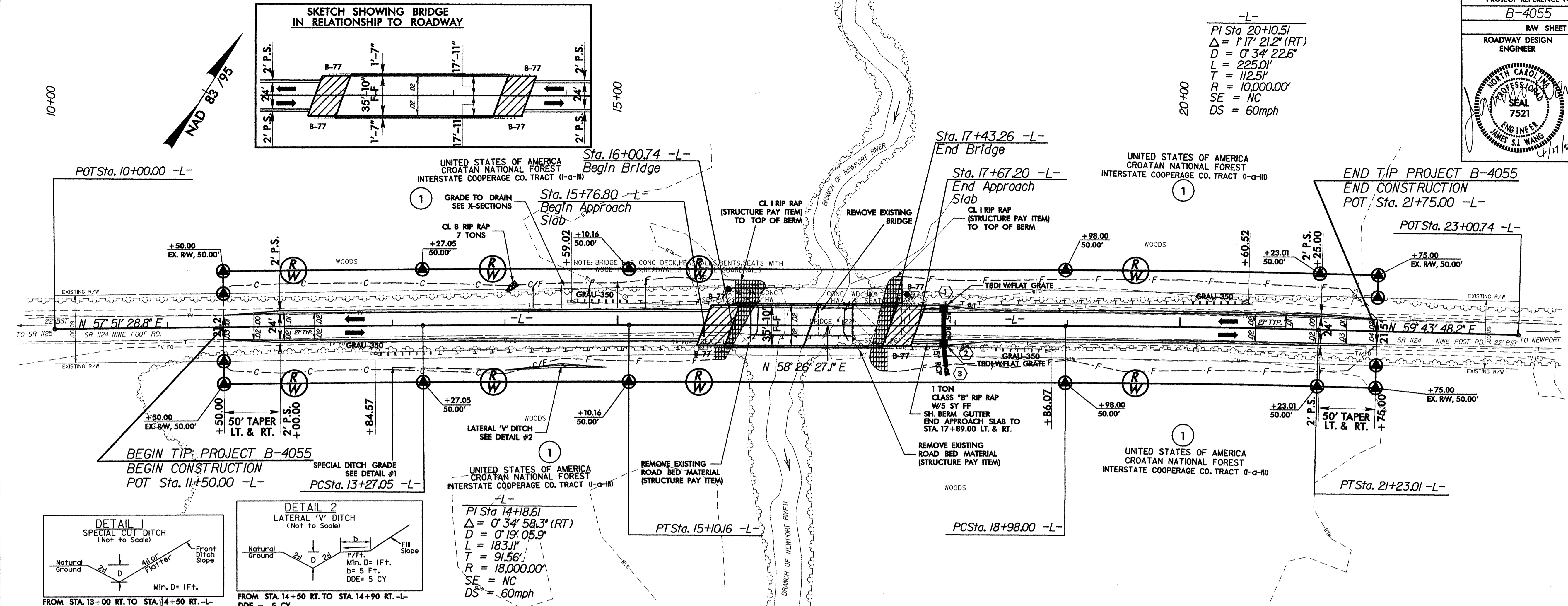
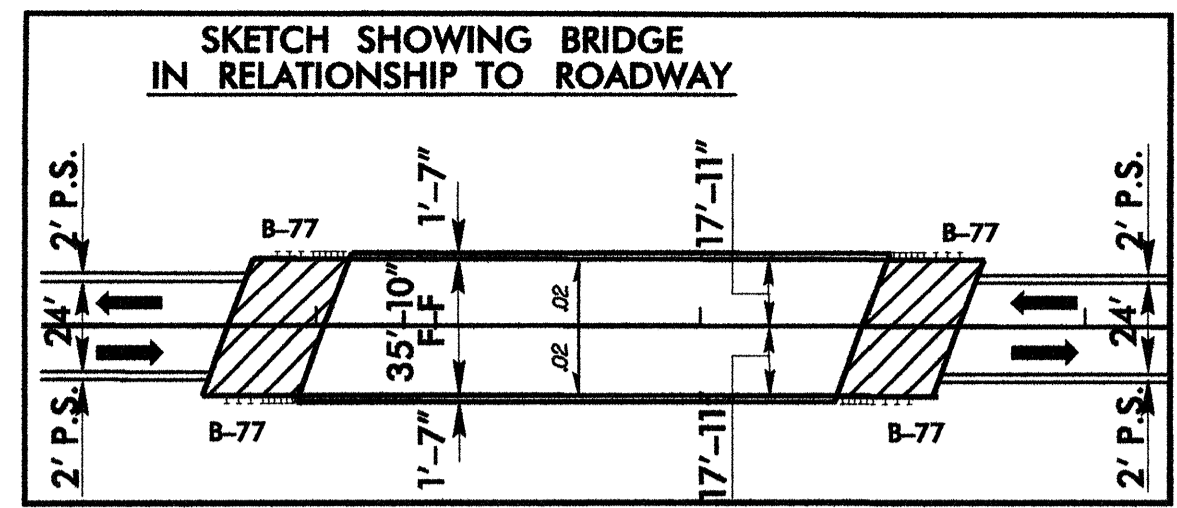

-L-
 PI Sta 14+18.61
 $\Delta = 0' 34' 58.3" (RT)$
 $D = 0' 19' 05.9"$
 $L = 183.11'$
 $T = 91.56'$
 $R = 18,000.00'$
 $SE = NC$
 $DS = 60mph$

BRIDGE HYDRAULIC DATA

DESIGN DISCHARGE	= 1,990 CFS
DESIGN FREQUENCY	= 25 YR
DESIGN HW ELEVATION	= 10.8'
BASE DISCHARGE	= 3,530 CFS
BASE FREQUENCY	= 100 YR
BASE HW ELEVATION	= 12.5'
OVERTOPPING DISCHARGE	= 4,450 CFS
OVERTOPPING FREQUENCY	= 200 YR
OVERTOPPING ELEVATION	= 13.0'
DATE OF SURVEY	= 3/2/05
W.S. ELEVATION AT DATE OF SURVEY	= 2.9'

SEE STRUCTURE PLANS S-1 THRU S-23

