

09/05/99

T.I.P. NO.	SHEET NO.
B-1382	UO-1

STATE OF NORTH CAROLINA
DIVISION OF HIGHWAYS

**UTILITY BY OTHERS PLANS
SAMPSON COUNTY**

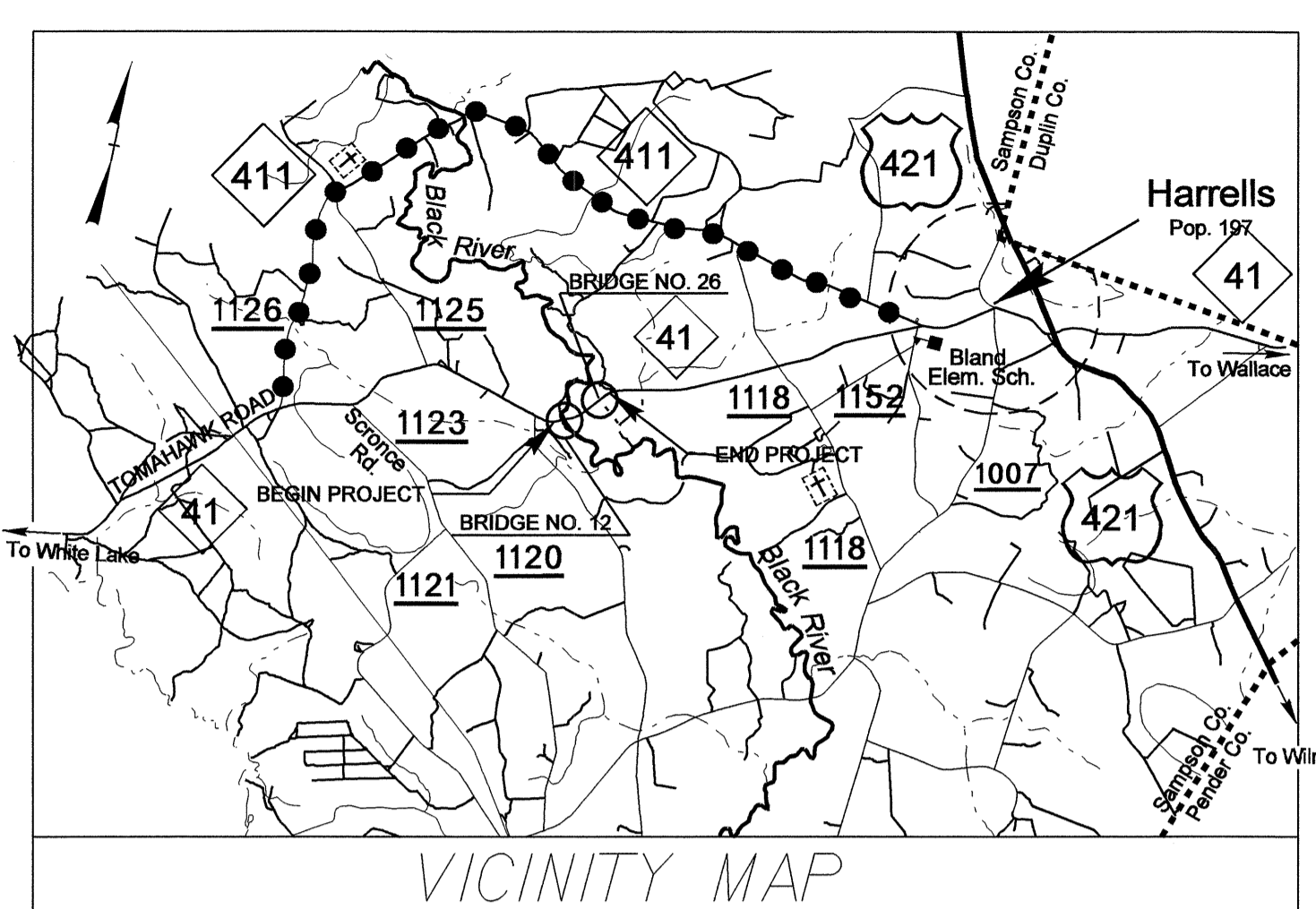

VICINITY MAP
THIS PROJECT IS NOT WITHIN ANY MUNICIPAL BOUNDARIES.
●●●● OFFSITE DETOUR ROUTE

LOCATION: BRIDGE NO. 12 AND NO. 26 OVER BLACK RIVER AND BLACK RIVER OVERFLOW ON NC 41 (TOMAHAWK ROAD)

TYPE OF WORK: UTILITIES BY OTHERS

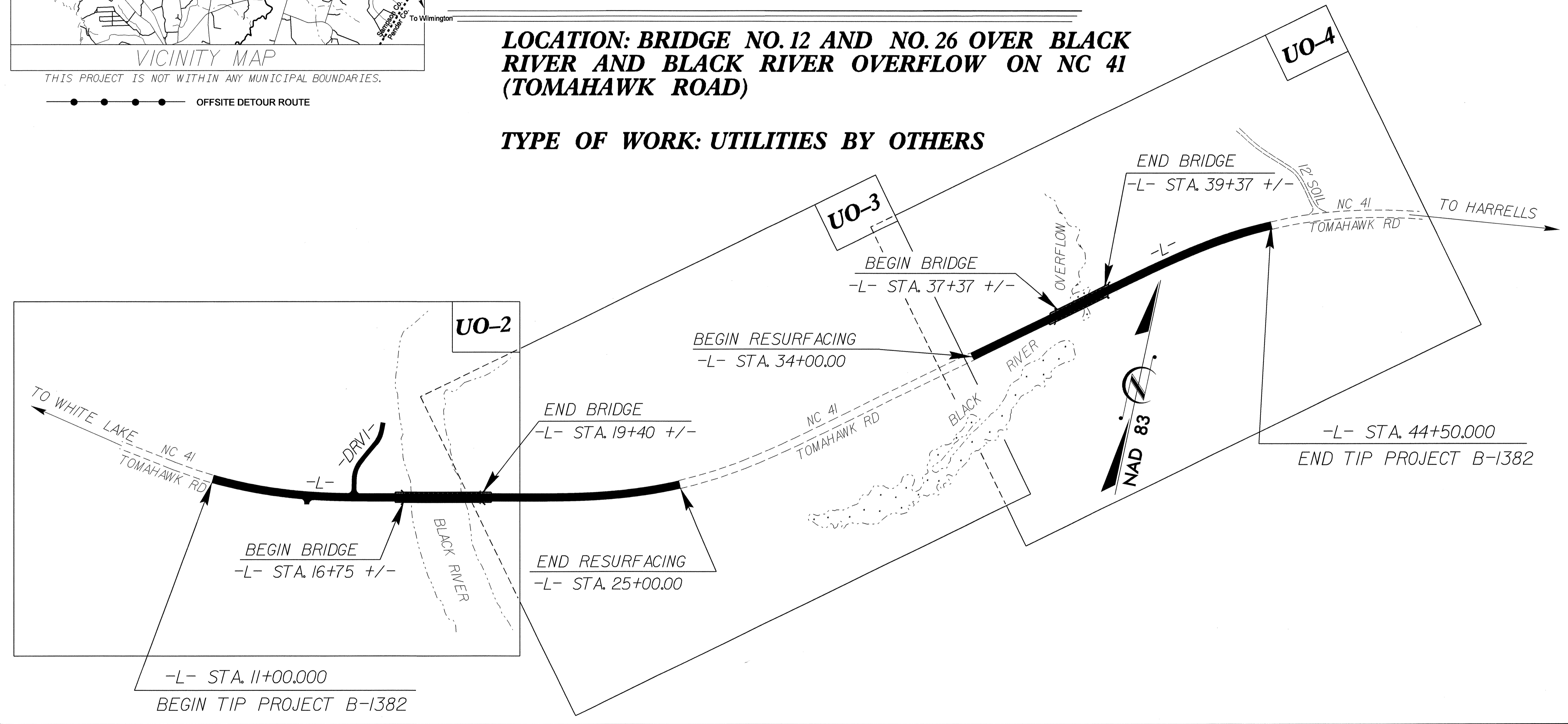

TIP PROJECT: B-1382

CONTRACT: C201605

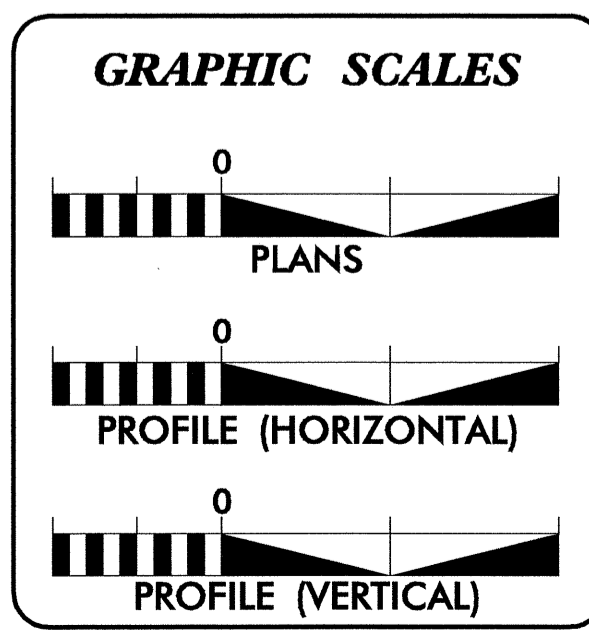

INDEX OF SHEETS

SHEET NO.	DESCRIPTION
UO-1	TITLE SHEET
UO-2 THRU UO-4	UTILITY BY OTHERS PLAN SHEETS

UTILITY OWNERS ON PROJECT

- (1) FOUR COUNTY EMC
- (2) STAR TELEPHONE

PREPARED IN THE OFFICE OF:
**DIVISION OF HIGHWAYS
PROJECT SERVICES
UTILITY SECTION**

1591 MAIL SERVICES CENTER
RALEIGH NC 27699-1591
PHONE (919) 250-4128
FAX (919) 250-4119

Roger Worthington, P.E. UTILITIES SECTION ENGINEER
R. B. WILKINS, P.E. UTILITIES SQUAD LEADER PROJECT ENGINEER
MICHAEL R. BRIGHT UTILITIES PROJECT DESIGNER

13-FEB-2008 10:54
F:\Utilities\pdy_ut\proj\bi382_ut_title_uol_psh.dgn
\$\$\$\$\$USERNAME\$\$\$\$\$

UTILITIES BY OTHERS

NOTE:
 ALL PROPOSED UTILITY WORK
 SHOWN ON THIS SHEET WILL
 BE DONE BY OTHERS

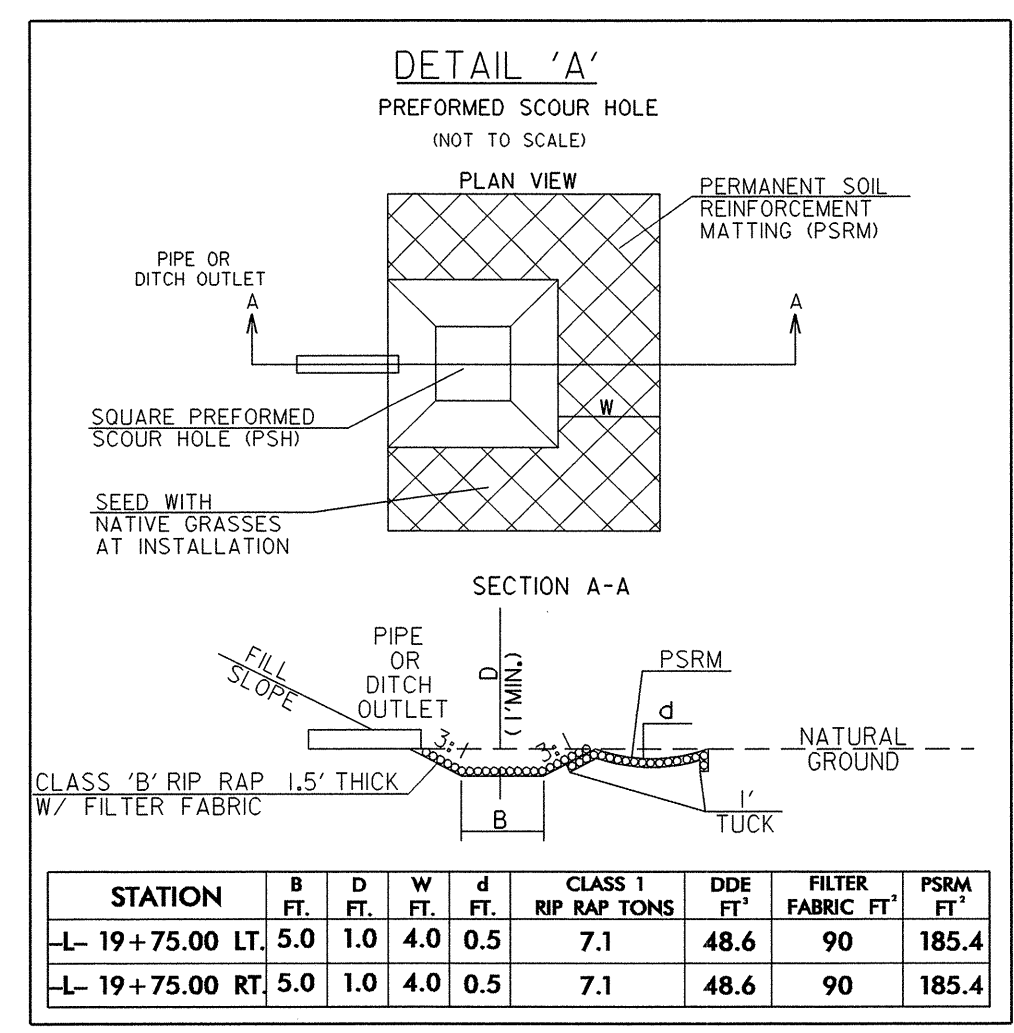
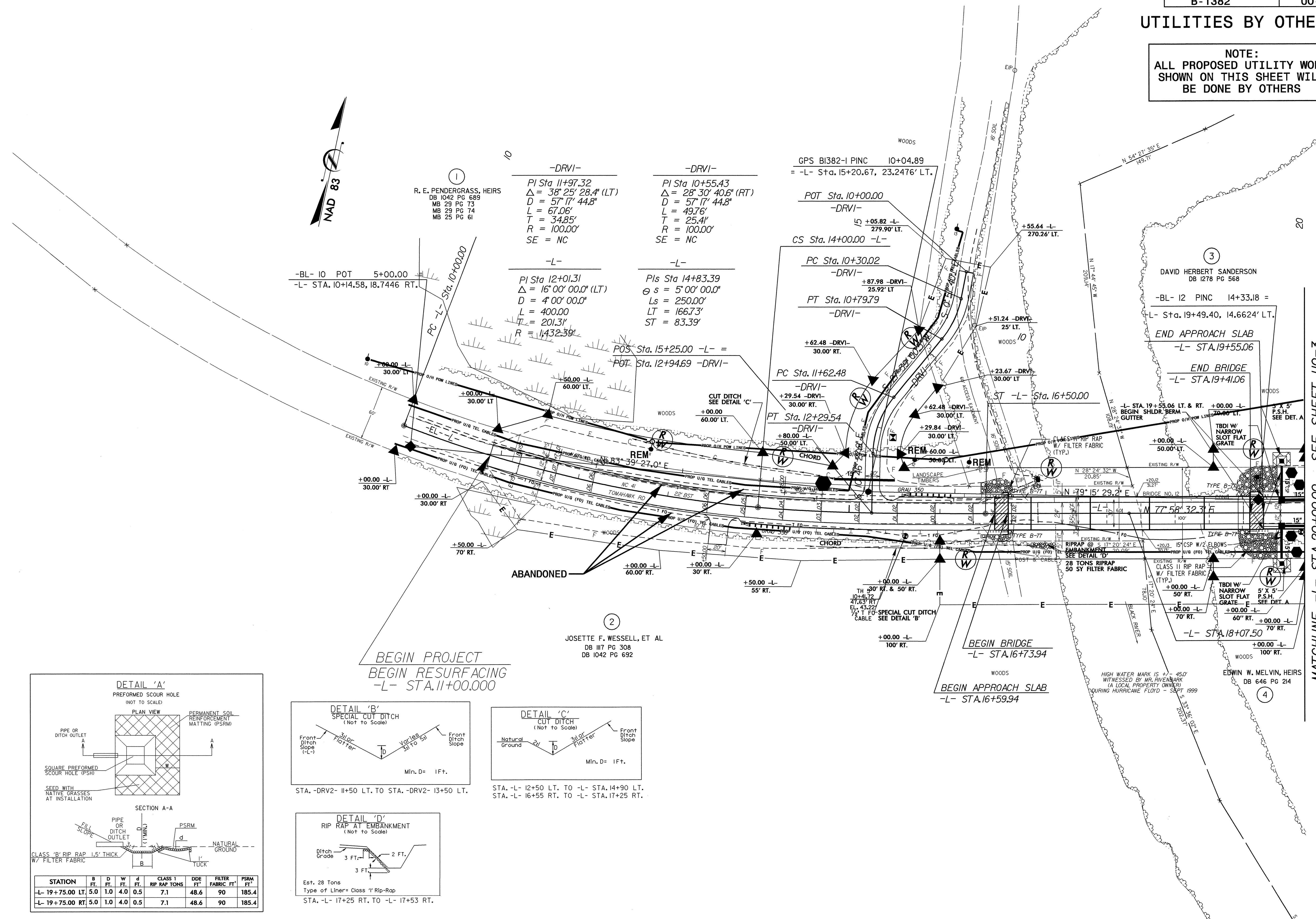

MATCHLINE -L- STA. 20+00.00 SEE SHEET UO-3

5/14/99
 13-FEB-2008 09:41
 J:\1382\ut_4_uo2.psh.dgn

