

STATE	STATE PROJECT REFERENCE NO.	SHEET NO.	TOTAL SHEETS
N.C.	B-5021	1	
WBS NO.	F.A. PROJ. NO.	DESCRIPTION	
41927.1.1	IMS-95-1 (76) 33	PE	
41927.2.1		R/W & UTILITY	
41927.3.1	IMS-095-1 (78) 33	CONSTRUCTION	

STATE OF NORTH CAROLINA
DIVISION OF HIGHWAYS

ROBESON COUNTY

**LOCATION: SPAN REPLACEMENTS ON BRIDGES 151, 162, 167, & 169
JACKING OF BRIDGES 54 & 100
LOCATED ALONG I-95**

**TYPE OF WORK: JACK STRUCTURES, SPAN REPLACEMENTS,
GRADING, PAVING, AND DRAINAGE**

See Sheets 1-9 For Bridge 151
See Sheets 10-19 For Bridge 54
See Sheets 20-29 For Bridge 100
See Sheets 30-43 For Bridge 162
See Sheets 44-53 For Bridge 167
See Sheets 54-62 For Bridge 169

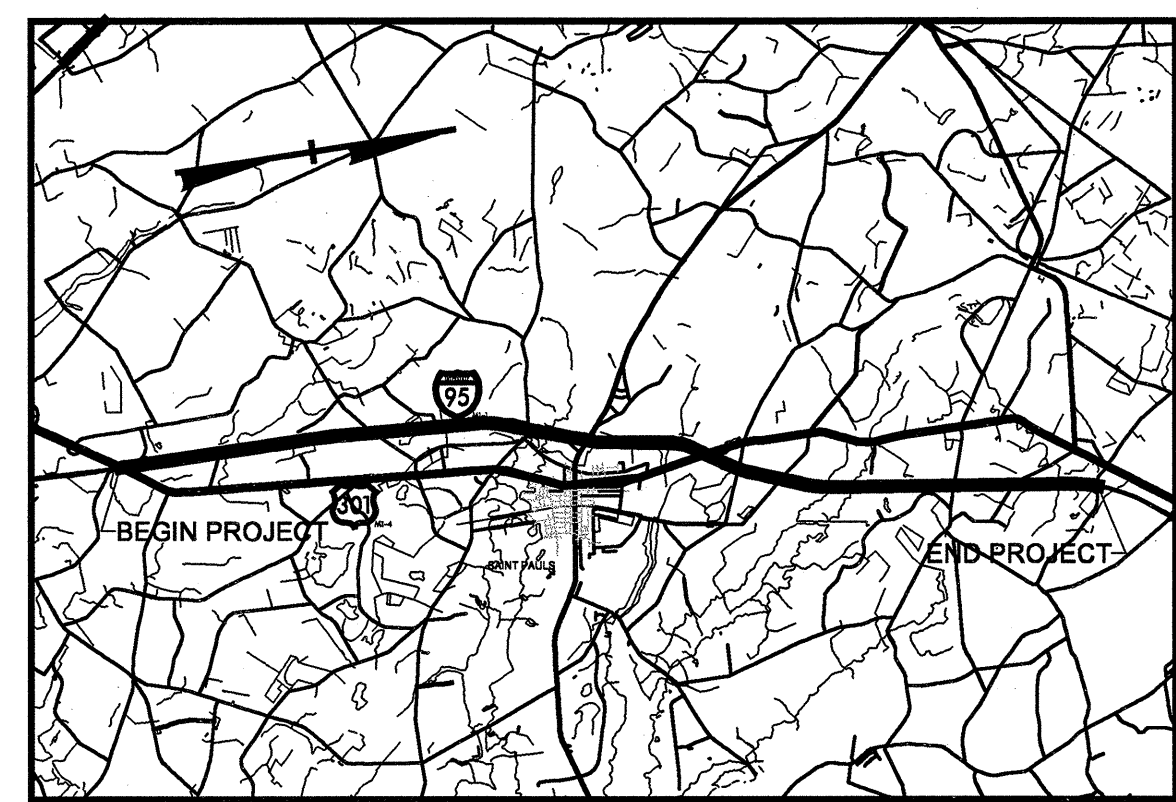

VICINITY MAP

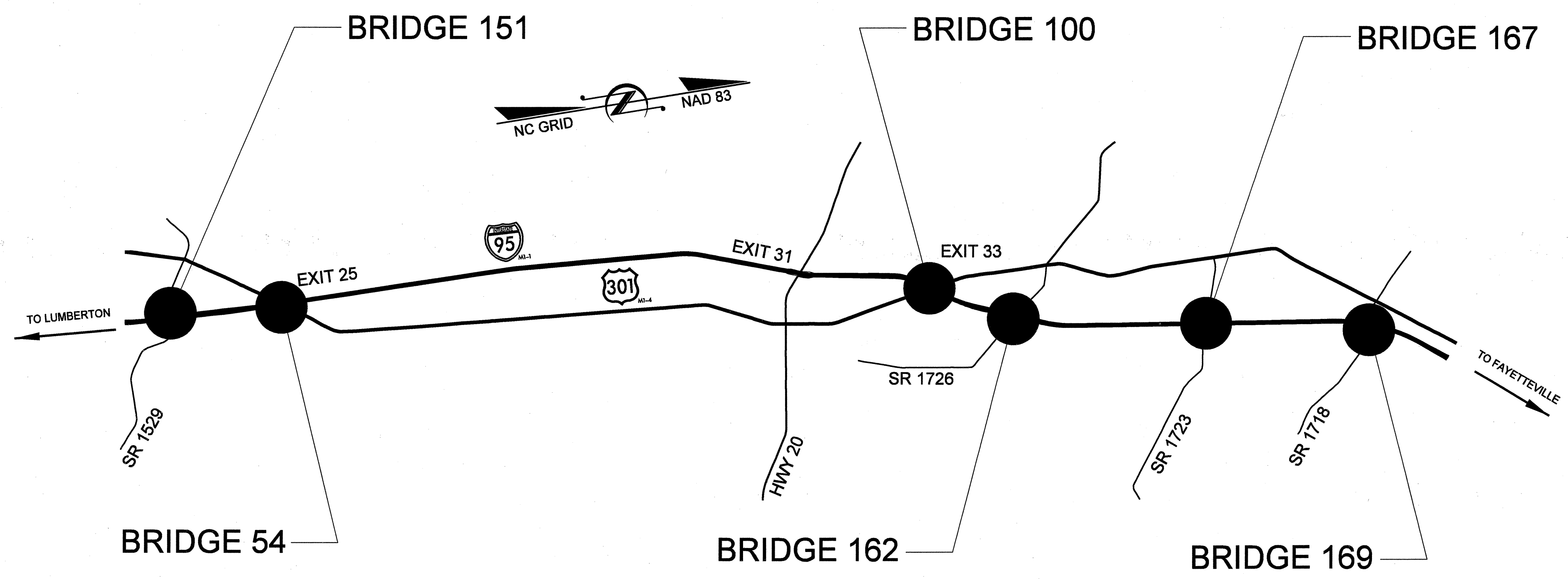

STRUCTURES

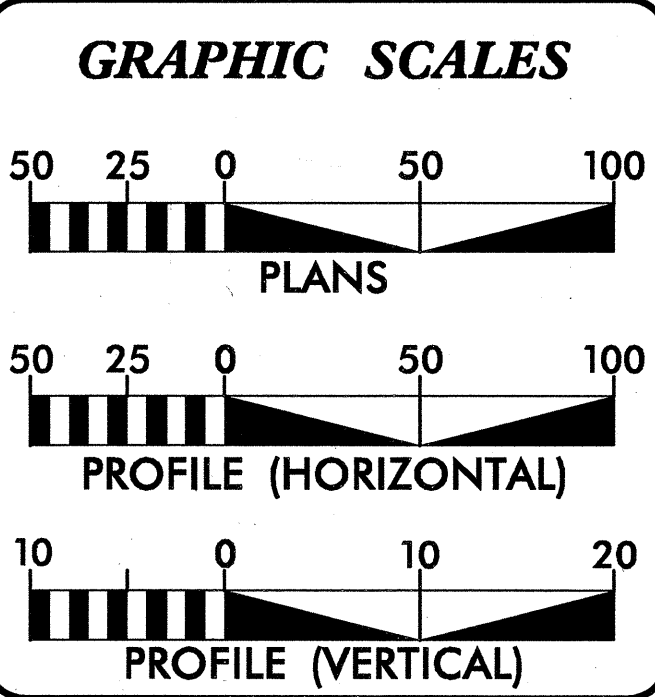

DESIGN DATA

V = 55 MPH

Prepared in the Office of:
STV / Ralph Whitehead Associates, Inc.
1000 West Morehead St., Ste. 200
Charlotte, NC 28208

For the North Carolina Department of Transportation

2006 STANDARD SPECIFICATIONS

RIGHT OF WAY DATE: _____

LETTING DATE:
JULY 15, 2008

MARK F. ROBBINS, P.E.
PROJECT ENGINEER

KEVIN G. BAILEY, P.E.
PROJECT DESIGN ENGINEER

DIVISION OF HIGHWAYS
STATE OF NORTH CAROLINA

STATE HIGHWAY DESIGN ENGINEER P.E.

S:\5\2008\N:\APR03\2513448\B5021\Roadway\Proj\B-5021.RDY...STRUCTURES.TSH.dgn

CONTRACT: C202079 TIP PROJECT: B-5021

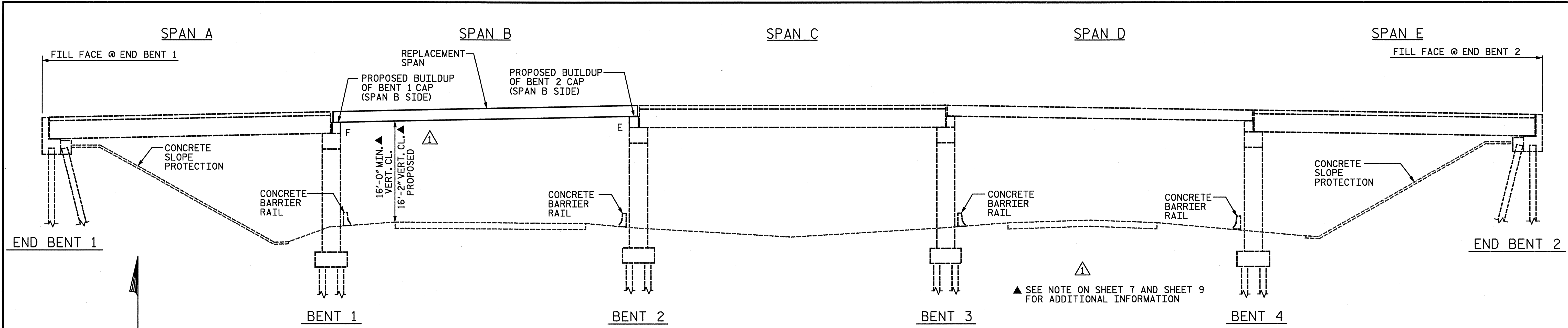

ALL DIMENSIONS IN THESE PLANS ARE BASED ON BEST AVAILABLE INFORMATION. THE CONTRACTOR SHALL VERIFY DIMENSIONS IN FIELD PRIOR TO CONSTRUCTION AND ANY FABRICATION, CONTRACTOR SHALL NOTIFY THE ENGINEER OF ANY DISCREPANCIES SUCH THAT NECESSARY ADJUSTMENTS BE MADE BY THE CONTRACTOR.

ELEVATION

SECTIONS AT BENTS AND END BENTS ARE AT RIGHT ANGLES

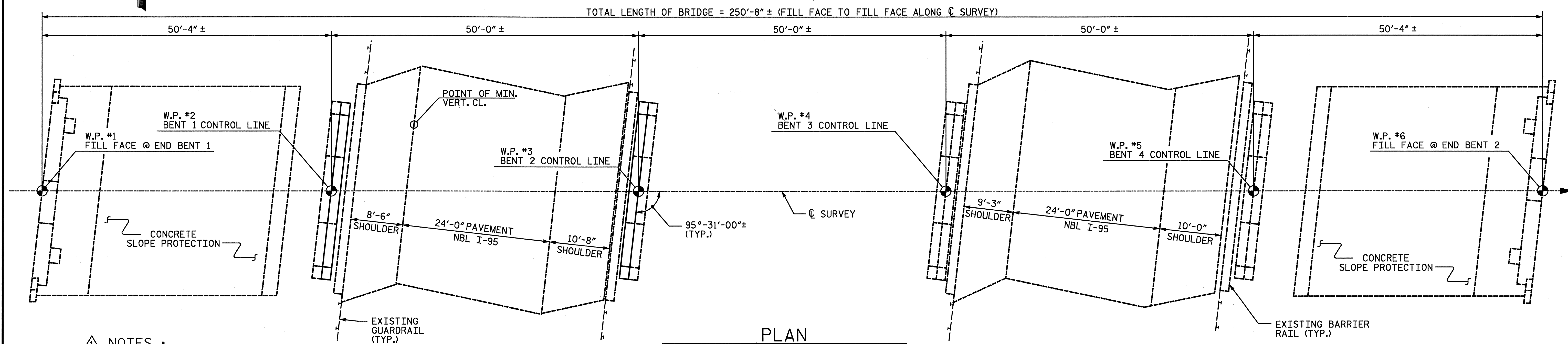

PLAN

PILES, FOOTINGS AND COLUMNS NOT SHOWN IN PLAN VIEW FOR CLARITY

NOTES:

- ASSUMED LIVE LOAD = HS 20 OR ALTERNATE LOADING.
- FOR OTHER DESIGN DATA AND GENERAL NOTES, SEE SHEET SN.
- CORED SLABS HAVE BEEN DESIGNED BY THE STRENGTH DESIGN METHOD AS SPECIFIED IN AASHTO STANDARD SPECIFICATIONS.
- SPAN B OF THE EXISTING STRUCTURE CONSISTING OF 50'-0" PRESTRESSED CONCRETE GIRDERS, 24'-0" CLEAR ROADWAY WIDTH, REINFORCED CONCRETE DECK SHALL BE REMOVED. FOR PARTIAL REMOVAL OF EXISTING STRUCTURE, SEE SPECIAL PROVISIONS.
- FOR FALSEWORK AND FORMWORK, SEE SPECIAL PROVISIONS.
- FOR SUBMITTAL OF WORKING DRAWINGS, SEE SPECIAL PROVISIONS.
- FOR PRESTRESSED CONCRETE MEMBERS, SEE SPECIAL PROVISIONS.
- FOR CRANE SAFETY, SEE SPECIAL PROVISIONS.
- FOR MAINTENANCE & PROTECTION OF TRAFFIC BENEATH BRIDGE, SEE SPECIAL PROVISIONS.

TOTAL BILL OF MATERIAL						
	PARTIAL REMOVAL OF EXISTING STRUCTURE	CLASS AA CONCRETE	REINFORCING STEEL	CONCRETE BRIDGE RAIL	ELASTOMERIC BEARINGS	3'-0" X 1'-9" PRESTRESSED CONCRETE CORED SLABS
	LUMP SUM	CU. YDS.	LBS.	LIN. FT.	LUMP SUM	LIN. FT.
SUPERSTRUCTURE	LUMP SUM			99.75	LUMP SUM	448.88
BENT 1		4.6	800			
BENT 2		4.4	793			
TOTAL	LUMP SUM	9.0	1,593	99.75	LUMP SUM	448.88

REVISION #1: REVISED PER REVIEW COMMENTS
 BY: TJT DATE: 5-08
 CH'KD BY: KGB DATE: 5-08

PROJECT NO. **B-5021**
 ROBESON COUNTY
 BRIDGE: **151**

MODIFICATION OF BRIDGE NO. 151

STATE OF NORTH CAROLINA
 DEPARTMENT OF TRANSPORTATION
 RALEIGH
GENERAL DRAWING
BRIDGE OVER I-95
ON SR 1529

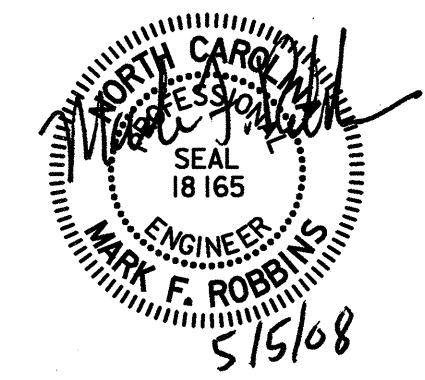
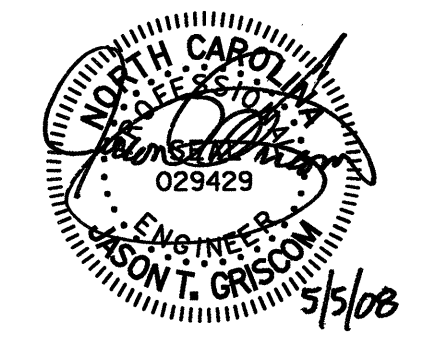

DRAWN BY: **JTG** DATE: **02-08**
 CHECKED BY: **TBQ** DATE: **03-08**

D-1809.1
STV/Ralph Whitehead Associates, Inc.
 1000 West Morehead St., Ste. 200
 Charlotte, NC 28208

REVISIONS						SHEET NO.
NO.	BY:	DATE:	NO.	BY:	DATE:	S-1
1	STV	5-08	3			TOTAL SHEETS
2			4			62

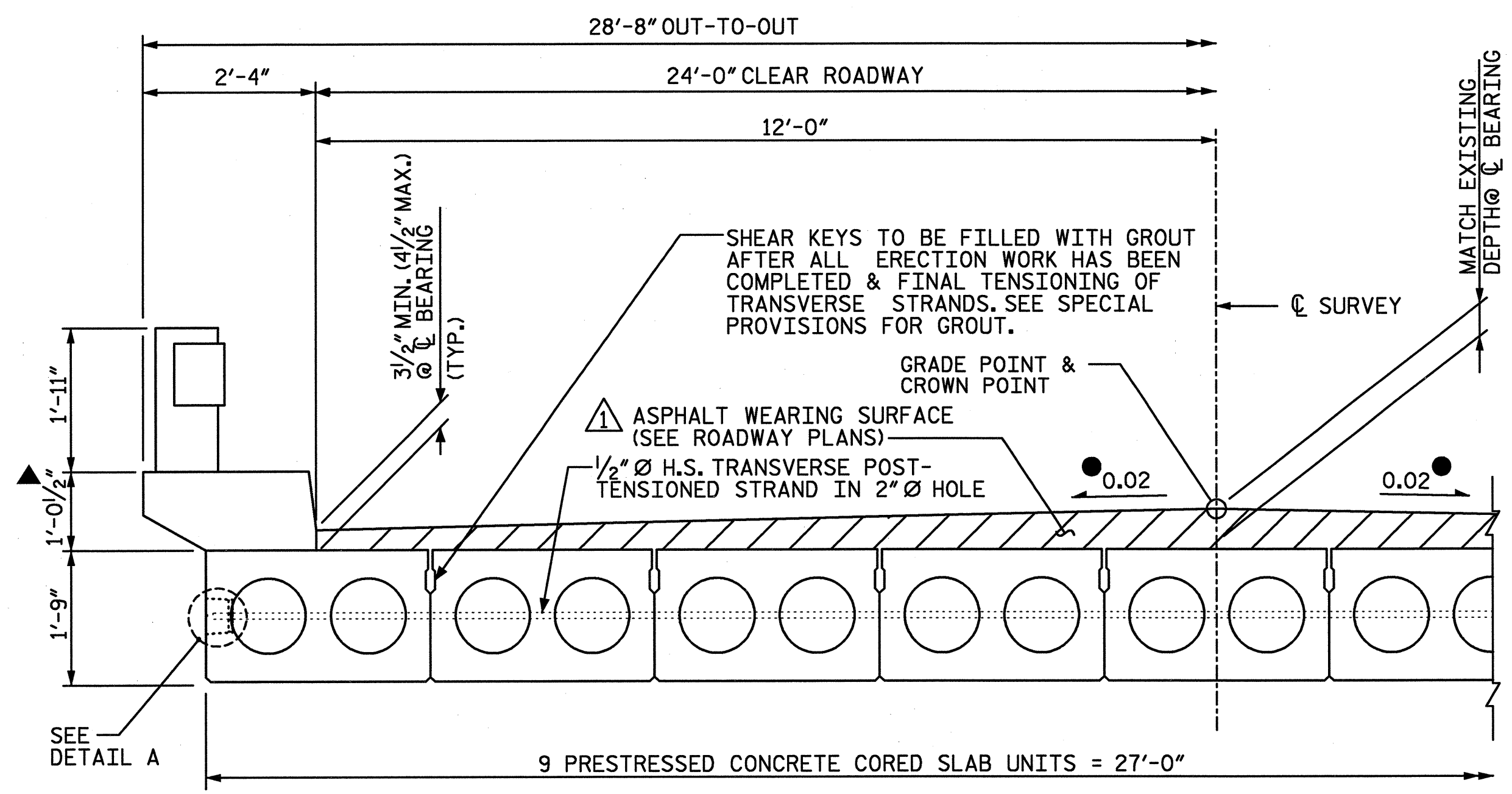

TYPICAL HALF SECTION
(BRIDGE SYMMETRIC ABOUT C SURVEY)

▲ CURB HEIGHT MAY NEED TO BE ADJUSTED TO MATCH TOP OF CURB IN ADJACENT SPAN. REINFORCING SHALL BE ADJUSTED TO MATCH THE REVISED CURB HEIGHT.

● CONTRACTOR SHALL MAKE A SMOOTH TRANSITION TO MATCH EXISTING CROSS SLOPE ON ROADWAY APPROACHES.

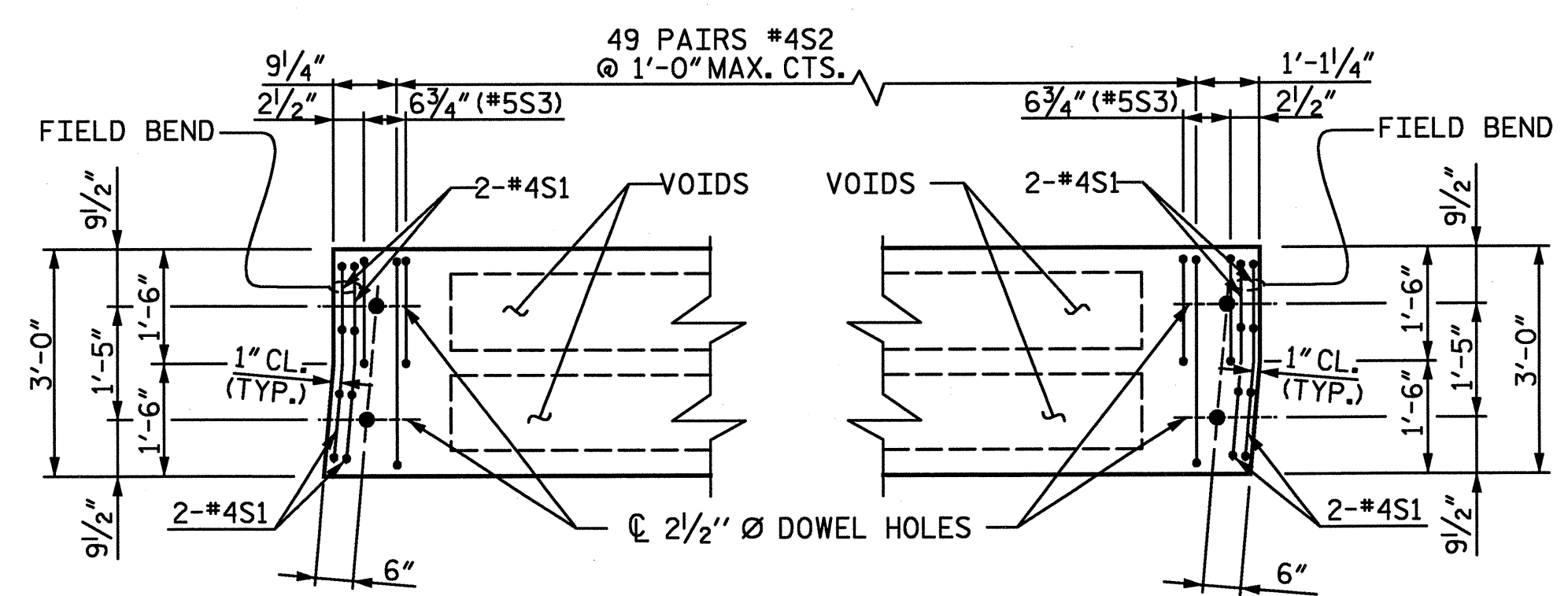

PART PLAN EXTERIOR SLAB SECTION
(LEFT SIDE SHOWN, RIGHT SIDE SIMILAR BY SYMMETRY)

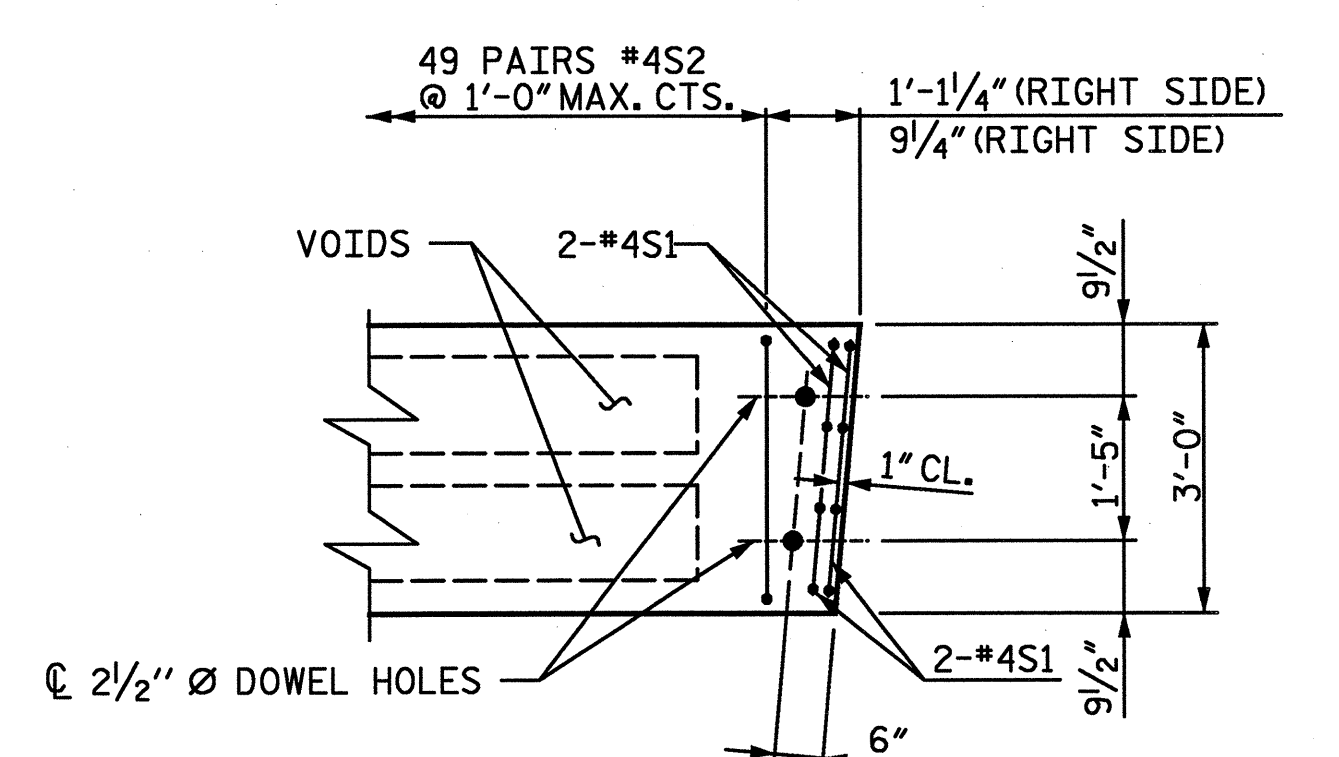

PART PLAN INTERIOR SLAB SECTION
(FAR END SHOWN, NEAR END SIMILAR BY SYMMETRY)

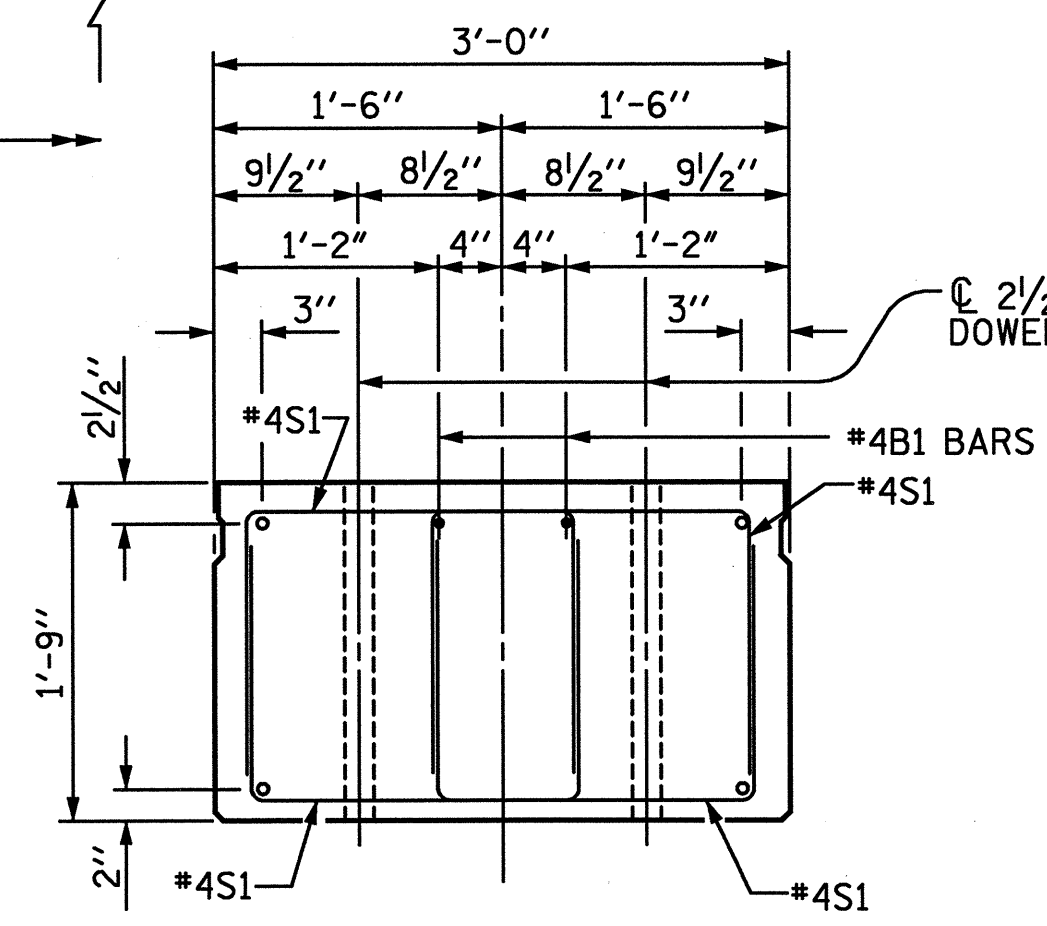

SLAB END ELEVATION

SHOWING PLACEMENT OF DOUBLE STIRRUPS AND LOCATION OF DOWEL HOLES.
INTERIOR SLAB SECTION SHOWN, EXTERIOR SLAB SECTION SIMILAR EXCEPT SHEAR KEY LOCATION.
STRAND LAYOUT NOT SHOWN.

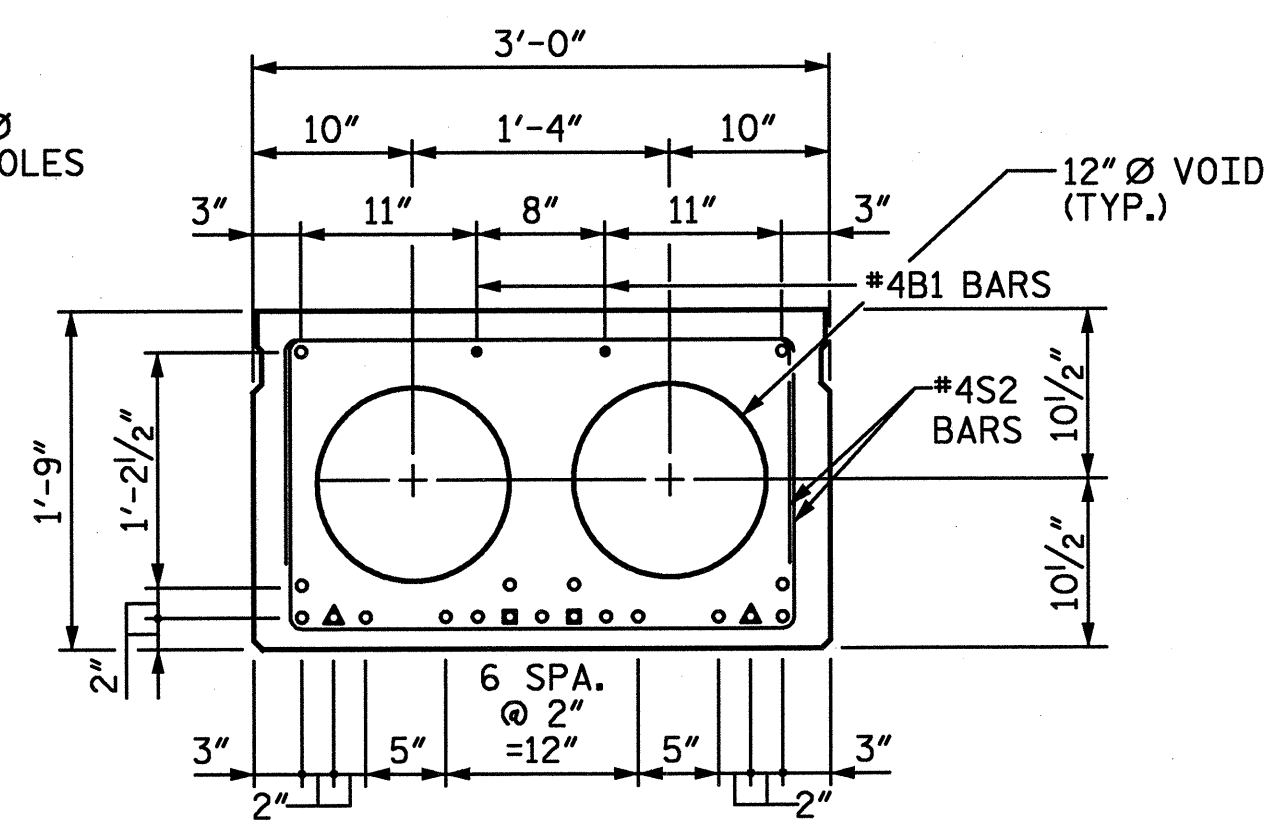

INTERIOR SLAB SECTION

(19 TOTAL STRANDS REQUIRED)
○ DENOTES 1/2" Ø L.R. STRANDS
△ DENOTES SHEATHED STRAND. BOND SHALL BE BROKEN ON THESE STRANDS FOR A DISTANCE OF 2'-0" FROM END OF SLAB.
□ DENOTES SHEATHED STRAND. BOND SHALL BE BROKEN ON THESE STRANDS FOR A DISTANCE OF 4'-0" FROM END OF SLAB.
SEE STANDARD SPECIFICATIONS ARTICLE 1078-7.

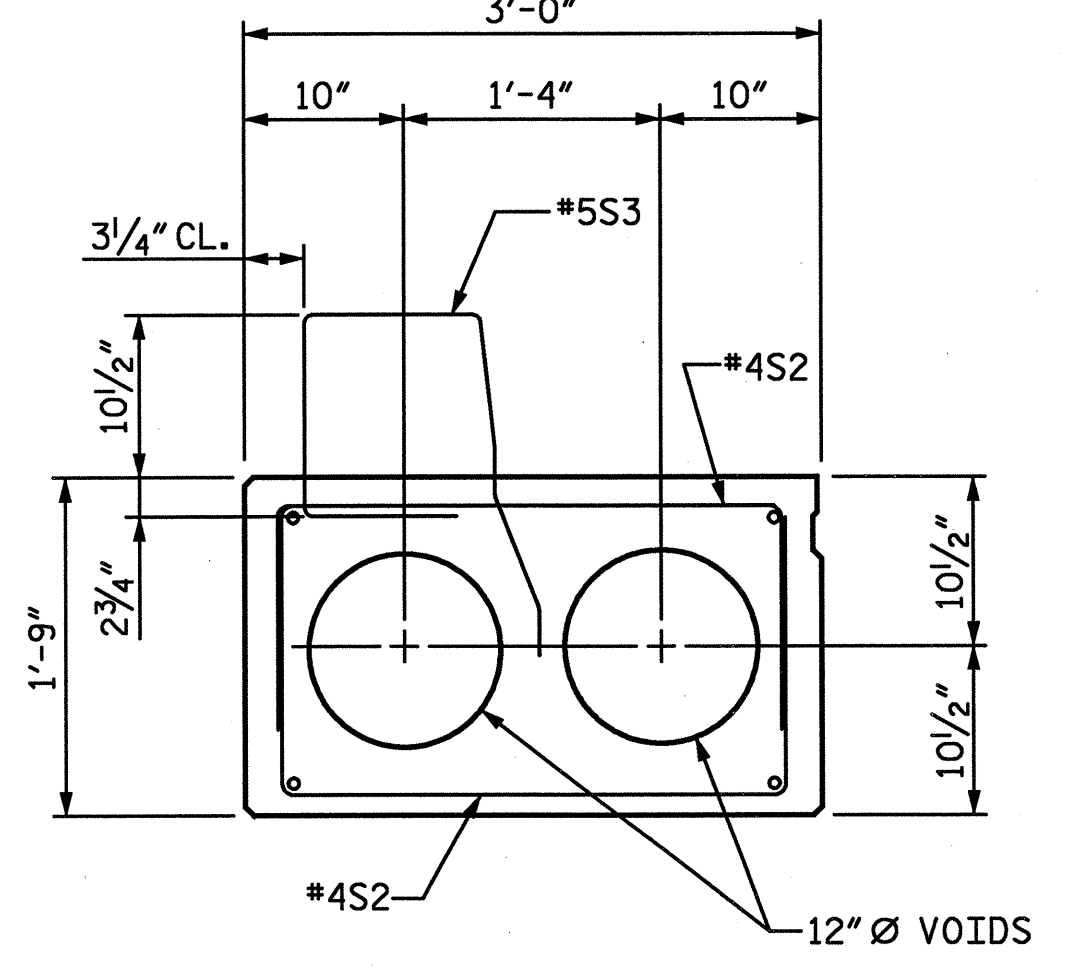

EXTERIOR SLAB SECTION

(FOR PRESTRESSED STRAND AND #4B1 BAR LAYOUT, SEE INTERIOR SLAB SECTION)

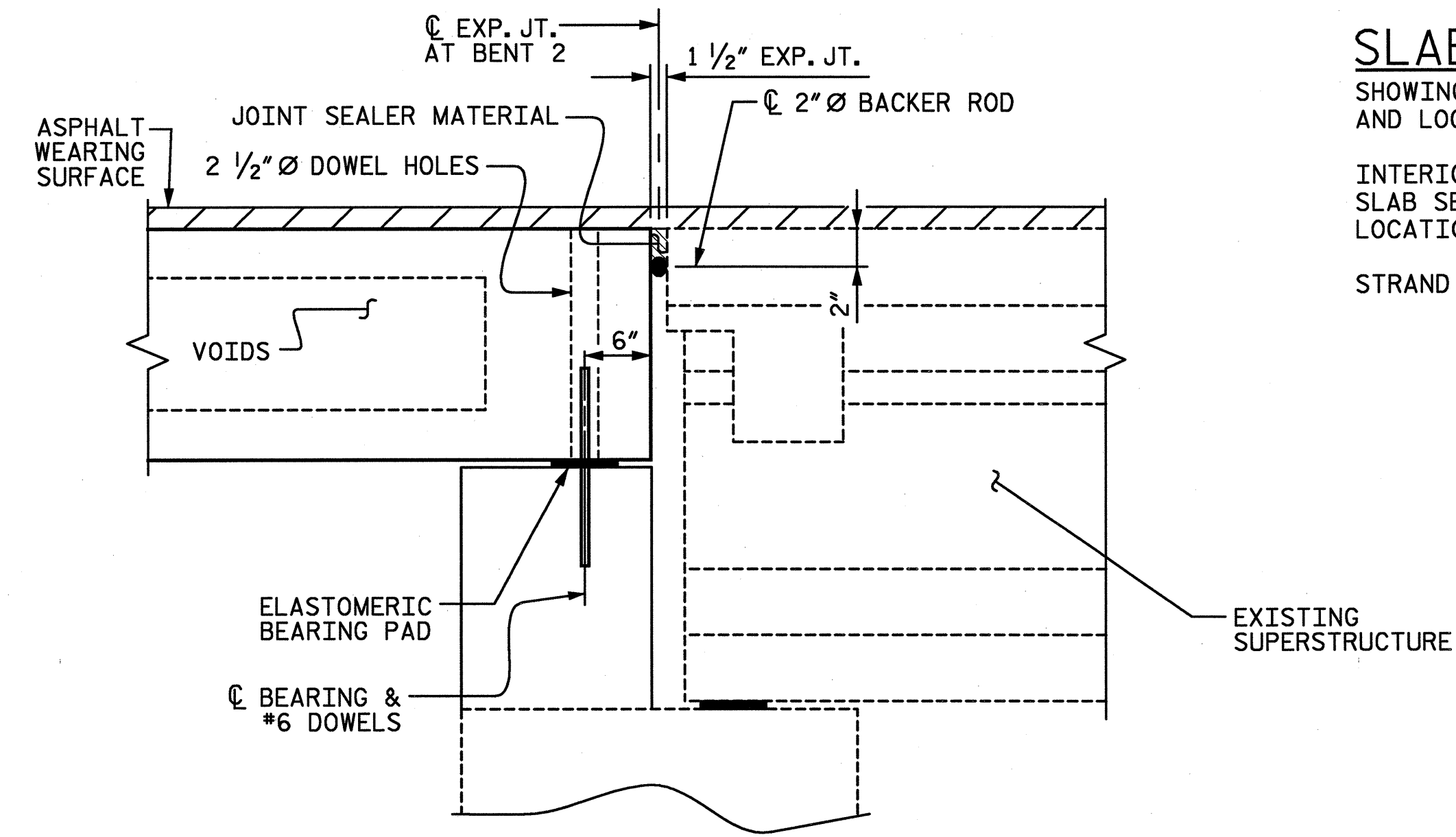

SECTION AT BENT 2
(BENT 1 SIMILAR BY SYMMETRY)

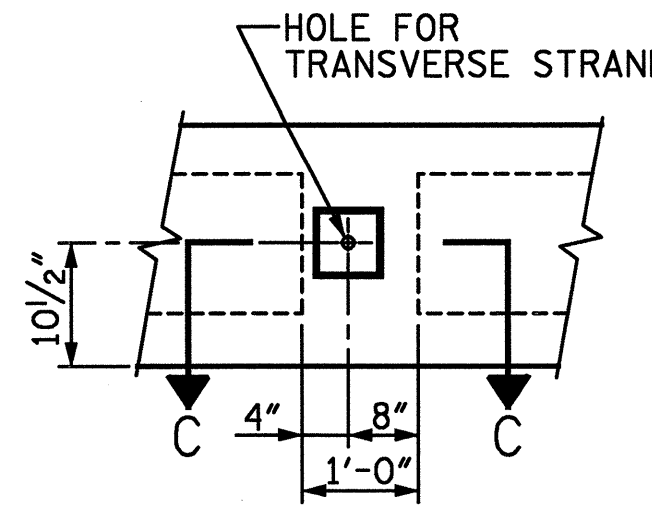

ELEVATION VIEW

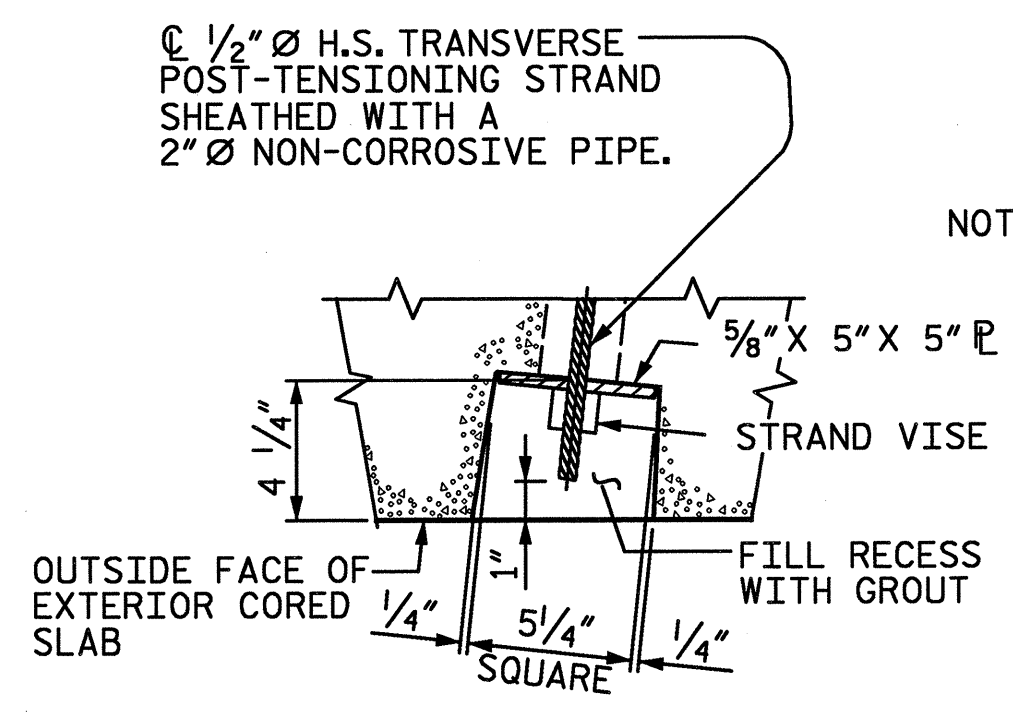

SECTION C-C

DETAIL A

GROUTED RECESS AT END OF POST-TENSIONED STRAND CORED SLABS

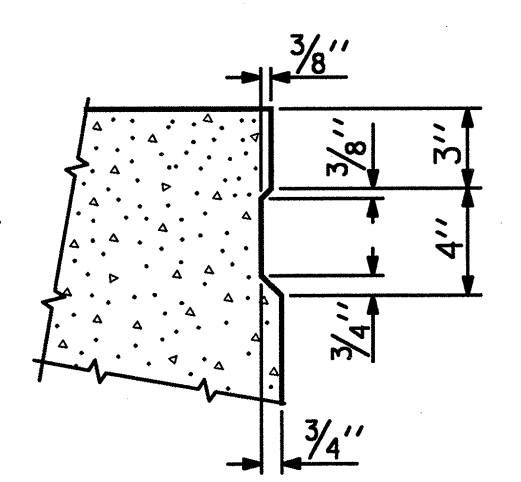

SHEAR KEY DETAIL

NOTE: OMIT SHEAR KEY ON OUTSIDE FACE OF EXTERIOR CORED SLAB

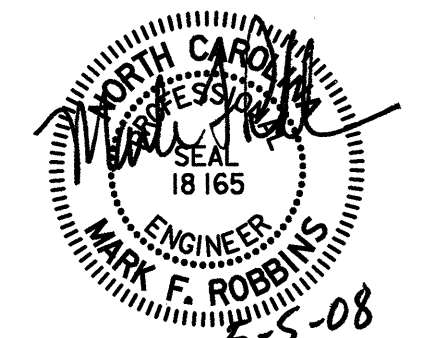
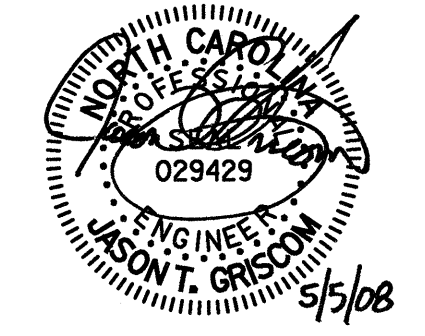

PROJECT NO. **B-5021**
ROBESON COUNTY
BRIDGE: **151**

SHEET 1 OF 4

STATE OF NORTH CAROLINA
DEPARTMENT OF TRANSPORTATION
RALEIGH

3'-0" X 1'-9" PRESTRESSED CORED SLAB

DRAWN BY: **TRL** DATE: **2-08**
CHECKED BY: **TBQ** DATE: **3-08**

REVISION #1: REVISED PER REVIEW COMMENTS
BY: **TJT** DATE: **5-08**
CH'KD BY: **KGB** DATE: **5-08**

D-1809.2
STV / Ralph Whitehead Associates, Inc.
1000 West Morehead St., Ste. 200
Charlotte, NC 28203

REVISIONS				SHEET NO.
NO.	BY:	DATE:	NO.	DATE:
1	STV	5-08	3	
2			4	

3-2
TOTAL SHEETS
62

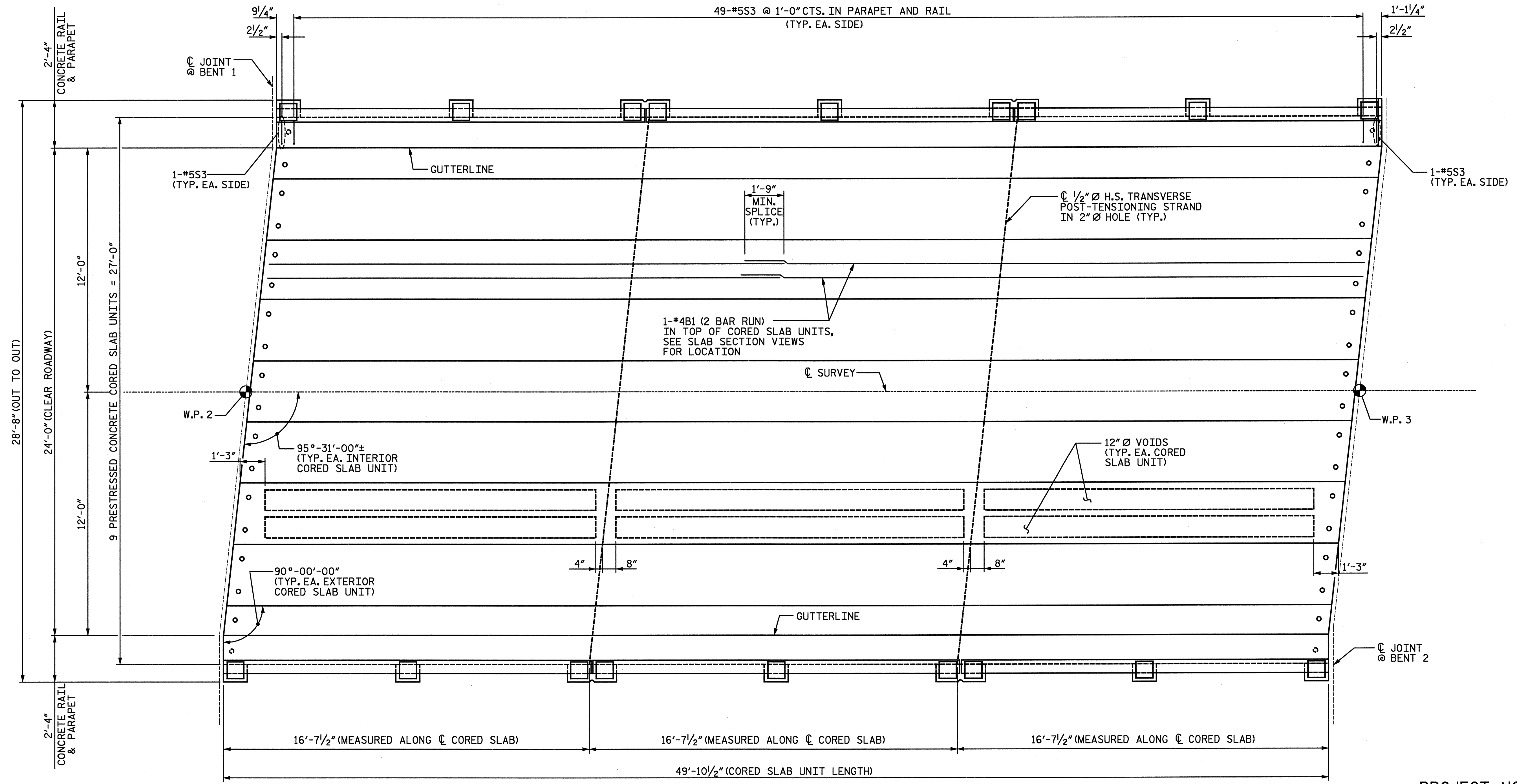

PLAN OF SPAN B

FOR ADDITIONAL CONCRETE RAIL REINFORCING STEEL & DETAILS, SEE "CONCRETE BRIDGE RAIL" SHEET.

PROJECT NO. **B-5021**
ROBESON COUNTY
 BRIDGE: **151**

SHEET 2 OF 4

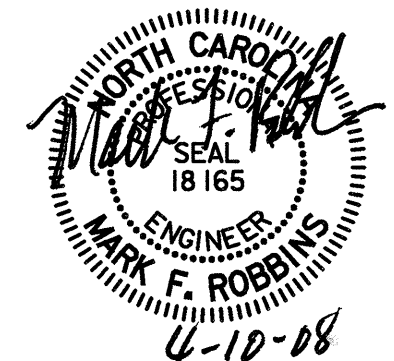
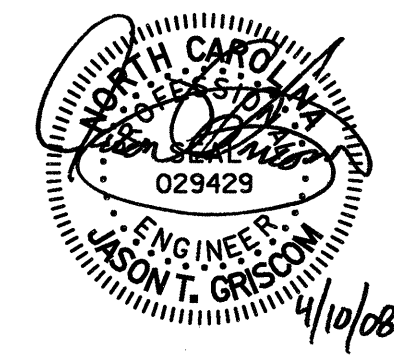

STATE OF NORTH CAROLINA
 DEPARTMENT OF TRANSPORTATION
 RALEIGH
**SUPERSTRUCTURE
 PLAN OF SPAN B**

DRAWN BY : **TRL** DATE : **1-08**
 CHECKED BY : **TBO** DATE : **3-08**

D-1809.3
STV / Ralph Whitehead Associates, Inc.
 1000 West Morehead St., Ste. 200
 Charlotte, NC 28208

REVISIONS					SHEET NO.
NO.	BY:	DATE:	NO.	BY:	DATE:
1			3		
2			4		

S-3
 TOTALS
 62

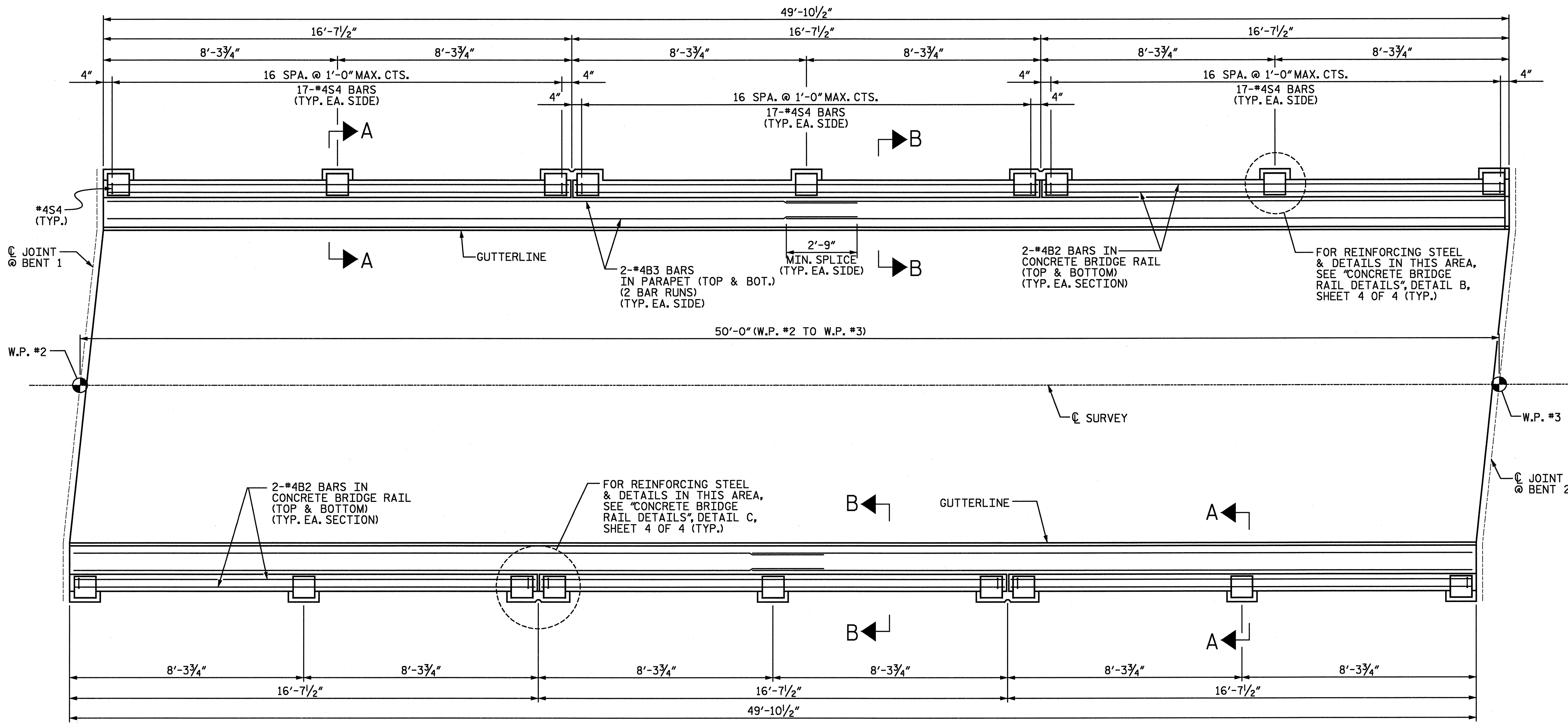

NOTE:
FOR SECTION VIEWS, SEE SHEET 4 OF 4.
CONCRETE BRIDGE RAIL SHALL BE CHAMFERED TO MATCH EXISTING RAIL. FOR CONCRETE BRIDGE RAIL, SEE SPECIAL PROVISIONS.

PLAN

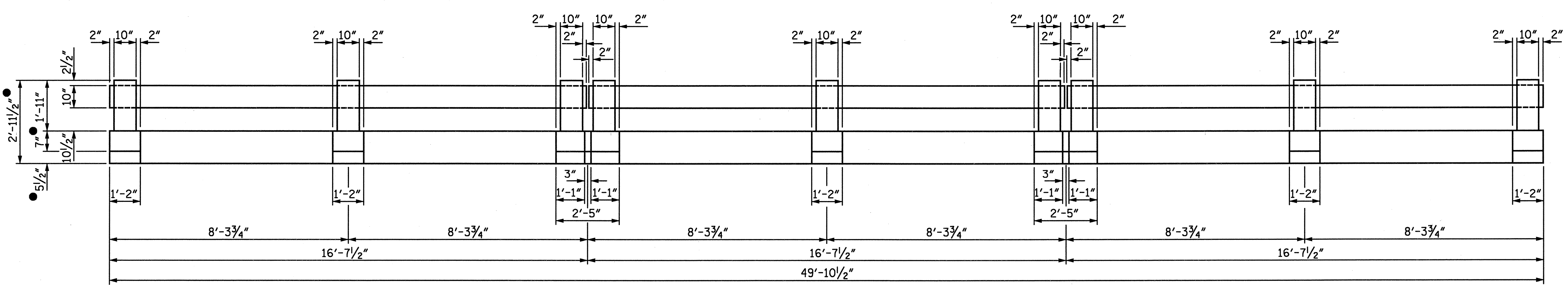

ELEVATION
(EXTERIOR OF RIGHT SIDE RAIL SHOWN, LEFT RAIL SIMILAR)

• DIMENSIONS MAY NEED TO BE ADJUSTED TO MATCH TOP OF RAIL IN ADJACENT SPAN. REINFORCING SHALL BE ADJUSTED TO MATCH THE REVISED RAIL HEIGHT.

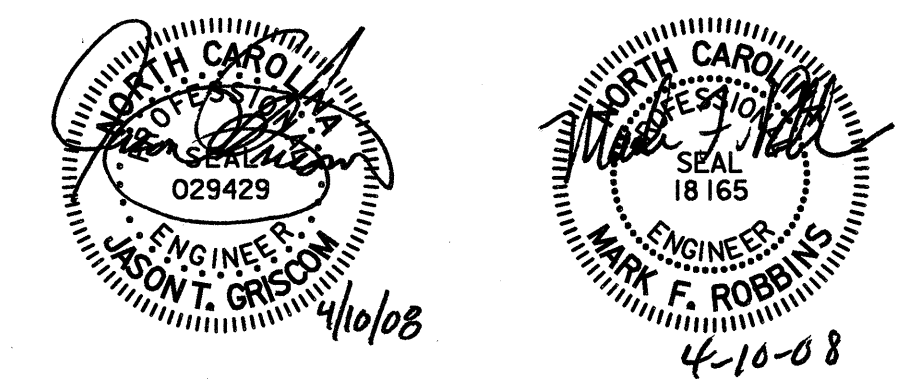

PROJECT NO. **B-5021**
ROBESON COUNTY
BRIDGE: **151**
SHEET 3 OF 4

STATE OF NORTH CAROLINA
DEPARTMENT OF TRANSPORTATION
RALEIGH

**SUPERSTRUCTURE
CONCRETE
BRIDGE RAIL**

BRIDGE 151

DRAWN BY : **TRL** DATE : **1-08**
CHECKED BY : **TBQ** DATE : **3-08**

D-1809.4
STV / Ralph Whitehead Associates, Inc.
1000 West Morehead St., Ste. 200
Charlotte, NC 28208

REVISIONS					SHEET NO.
NO.	BY:	DATE:	NO.	BY:	DATE:
1			3		
2			4		

TOTAL SHEETS: 62

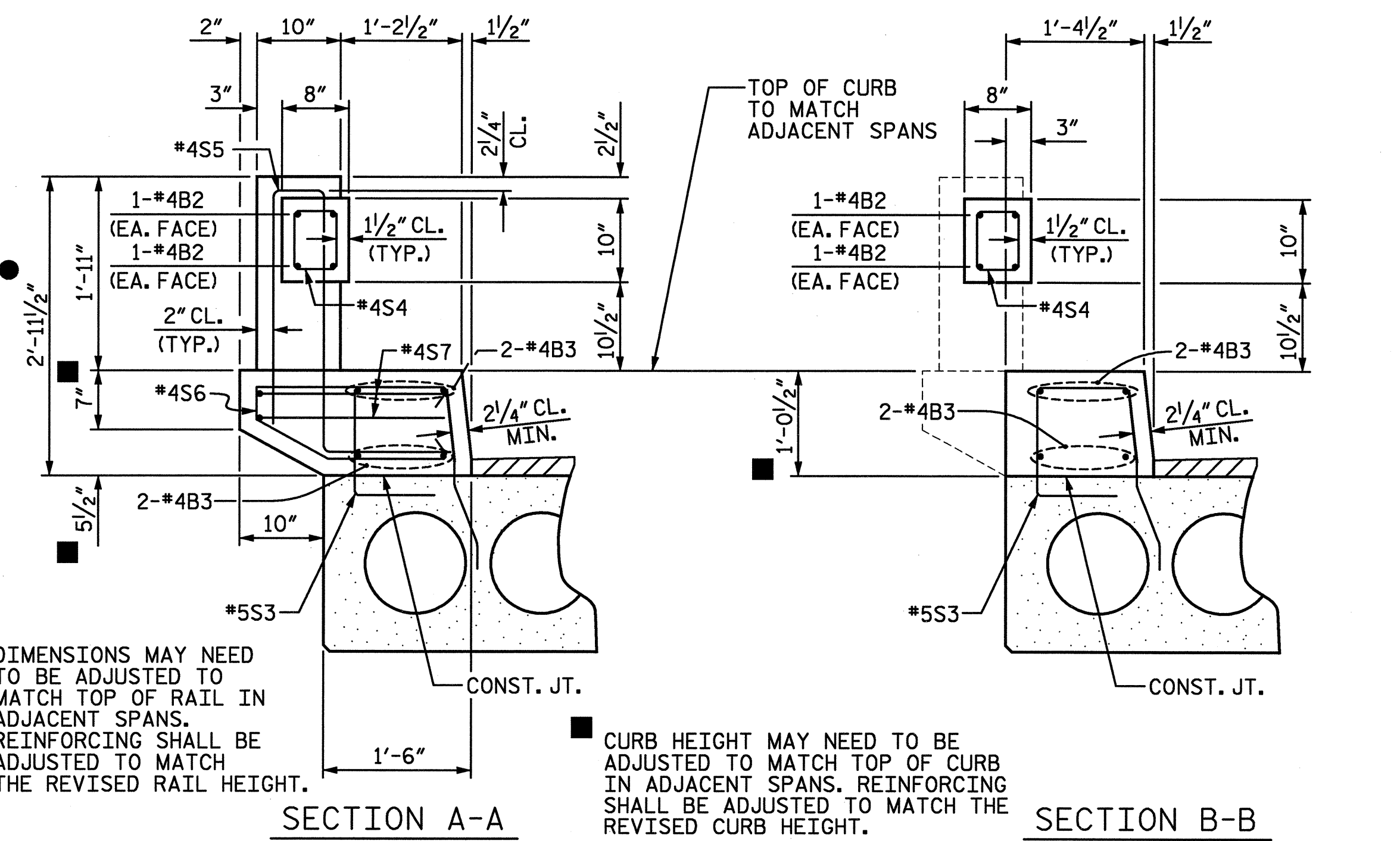

DIMENSIONS MAY NEED TO BE ADJUSTED TO MATCH TOP OF RAIL IN ADJACENT SPANS. REINFORCING SHALL BE ADJUSTED TO MATCH THE REVISED RAIL HEIGHT.

CURB HEIGHT MAY NEED TO BE ADJUSTED TO MATCH TOP OF CURB IN ADJACENT SPANS. REINFORCING SHALL BE ADJUSTED TO MATCH THE REVISED CURB HEIGHT.

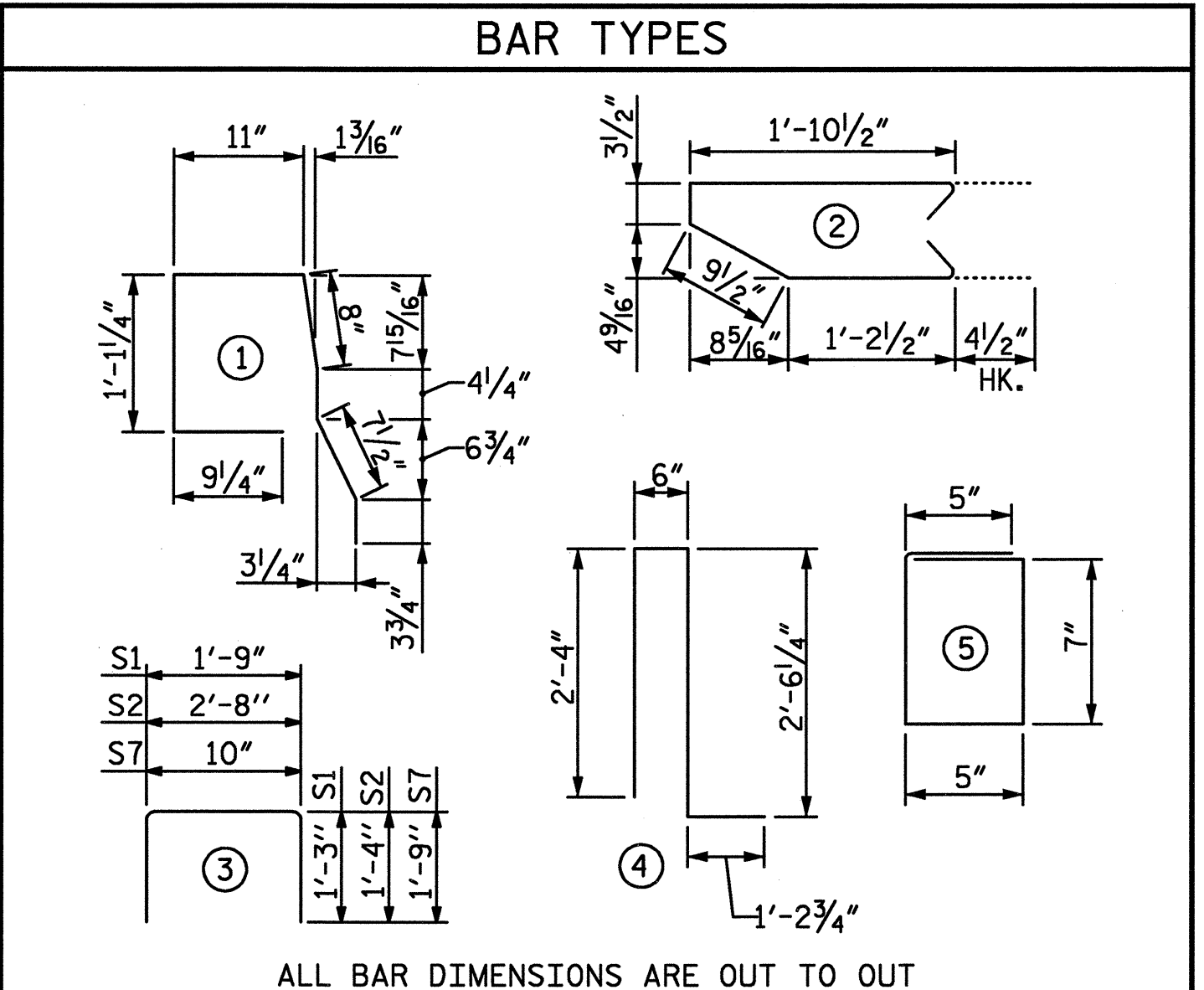

BILL OF MATERIAL FOR ONE CORED SLAB SECTION

BAR NUMBER	SIZE	TYPE	EXTERIOR UNIT		INTERIOR UNIT	
			LENGTH	WEIGHT	LENGTH	WEIGHT
B1	4	#4 STR	25'-8"	69	25'-8"	69
S1	16	#4	4'-3"	45	4'-3"	45
S2	98	#4	5'-4"	349	5'-4"	349
*S3	49	#5	4'-9"	243		
REINFORCING STEEL				463 LBS.		463 LBS.
*EPOXY COATED REINFORCING STEEL				243 LBS.		
5000 P.S.I. CONCRETE				7.0 CY		7.0 CY
1/2" Ø L.R. STRANDS			No.	19		19

DEAD LOAD DEFLECTION AND CAMBER

	3'-0" x 1'-9"
CAMBER (SLAB ALONE IN PLACE)	1 3/8"
DEFLECTION DUE TO SUPERIMPOSED DEAD LOAD**	1/4"
FINAL CAMBER	1 1/8"

** INCLUDES FUTURE WEARING SURFACE

BILL OF MATERIAL FOR CONCRETE BRIDGE RAIL AND PARAPET

BAR	TOTAL NO.	SIZE	TYPE	LENGTH	WEIGHT
*B2	24	#4	STR	16'-2"	259
*B3	16	#4	STR	26'-2"	280
*S4	102	#4	5	2'-5"	165
*S5	36	#4	4	6'-7"	158
*S6	36	#4	2	4'-11"	118
*S7	36	#4	3	4'-4"	104
*EPOXY COATED REINFORCING STEEL				1,084 LBS.	
CLASS AA CONCRETE				9.1 CY	
TOTAL LIN. FT. OF CONCRETE BARRIER RAIL				99'-9"	

CORED SLABS REQUIRED

	NUMBER	LENGTH	TOTAL LENGTH
EXTERIOR C.S.	2	49'-10 1/2"	99'-9"
INTERIOR C.S.	7	49'-10 1/2"	349'-1 1/2"
TOTAL	9		448'-10 1/2"

GRADE 270 STRANDS

	1/2" Ø L.R.
AREA (SQUARE INCHES)	0.153
ULTIMATE STRENGTH (LBS. PER STRAND)	41,300
APPLIED PRESTRESS (LBS. PER STRAND)	30,980

NOTES

ALL PRESTRESSING STRANDS SHALL BE 7-WIRE LOW RELAXATION GRADE 270 STRANDS AND SHALL CONFORM TO AASHTO M203 EXCEPT FOR SAMPLING REQUIREMENTS WHICH SHALL BE IN ACCORDANCE WITH THE STANDARD SPECIFICATIONS.

ALL REINFORCING STEEL CAST WITH THE CORED SLAB SECTIONS SHALL BE GRADE 60 AND SHALL BE INCLUDED IN THE UNIT PRICE BID FOR PRESTRESSED CONCRETE CORED SLABS.

RECESSES FOR TRANSVERSE STRANDS SHALL BE GROUTED AFTER THE TENSIONING OF THE STRANDS.

THE 2 1/2" Ø DOWEL HOLES AT FIXED ENDS OF SLAB SECTIONS SHALL BE FILLED WITH GROUT. THE 2 1/2" Ø DOWEL HOLES AT EXPANSION ENDS OF SLAB SECTIONS SHALL BE FILLED WITH JOINT SEALER MATERIAL TO 1/2" ABOVE THE TOP OF DOWELS AND THEN FILLED WITH GROUT.

THE JOINT SEALER MATERIAL SHALL CONFORM TO THE REQUIREMENTS OF TYPE SL LOW MODULUS SILICONE SEALANT. THE 2" Ø BACKER ROD SHALL CONFORM TO THE REQUIREMENTS OF TYPE M BOND BREAKER. SEE SECTION 1028 OF THE STANDARD SPECIFICATIONS. PAYMENT FOR JOINT SEALER MATERIAL SHALL BE CONSIDERED INCIDENTAL TO CONSTRUCTION OF THE BRIDGE.

WHEN CORED SLABS ARE CAST, A POSITIVE HOLD-DOWN SYSTEM SHALL BE EMPLOYED TO PREVENT VOIDS FROM RISING OR MOVING SIDWAYS. THIS SYSTEM SHALL BE DESIGNED TO BE LEFT IN PLACE UNTIL THE CONCRETE HAS REACHED RELEASE STRENGTH. AT LEAST THREE WEEKS PRIOR TO CASTING CORED SLABS, THE CONTRACTOR SHALL SUBMIT TO THE ENGINEER FOR REVIEW AND COMMENT, DETAILED DRAWINGS OF THE PROPOSED HOLD-DOWN SYSTEM. IN ADDITION TO STRUCTURAL DETAILS, LOCATION AND SPACING OF THE HOLD-DOWNS SHALL BE INDICATED.

THE TRANSFER OF LOAD FROM THE ANCHORAGES TO THE CORED SLAB UNIT SHALL BE DONE WHEN THE CONCRETE HAS REACHED A COMPRESSIVE STRENGTH OF NOT LESS THAN 4000 PSI.

ALL REINFORCING STEEL IN BARRIER RAILS SHALL BE EPOXY COATED. PRESTRESSING STRANDS SHALL BE CUT FLUSH WITH THE CORED SLAB UNIT ENDS.

APPLY EPOXY PROTECTIVE COATING TO CORED SLAB UNIT ENDS.

VERTICAL GROOVED CONTRACTION JOINTS, 1/2" IN DEPTH, SHALL BE TOOLED IN ALL EXPOSED FACES OF THE BRIDGE RAIL AND IN ACCORDANCE WITH ARTICLE 825-10(B) OF THE STANDARD SPECIFICATIONS. THE CONTRACTION JOINTS SHALL BE LOCATED AT A SPACING OF 8 FEET TO 10 FEET BETWEEN EXPANSION JOINTS AND NO CONTRACTION JOINTS ARE REQUIRED FOR THOSE SEGMENTS LESS THAN 10 FEET IN LENGTH.

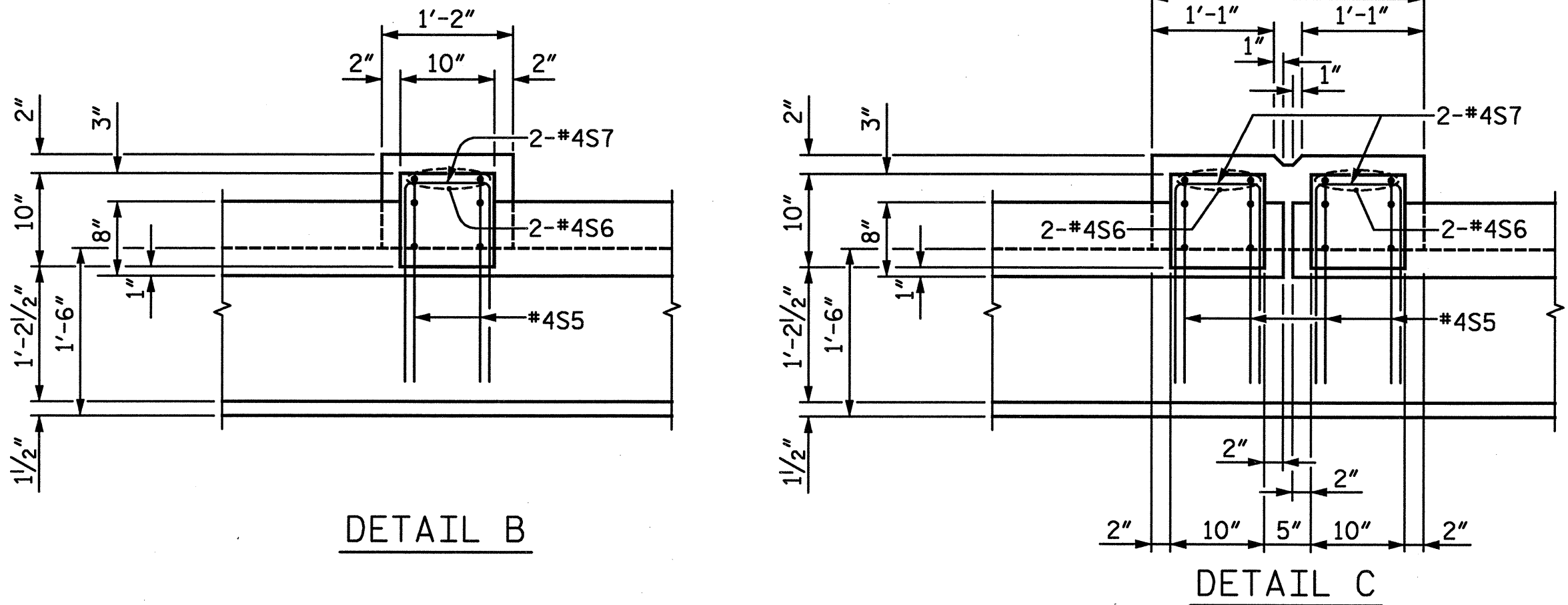

CONCRETE BRIDGE RAIL DETAILS

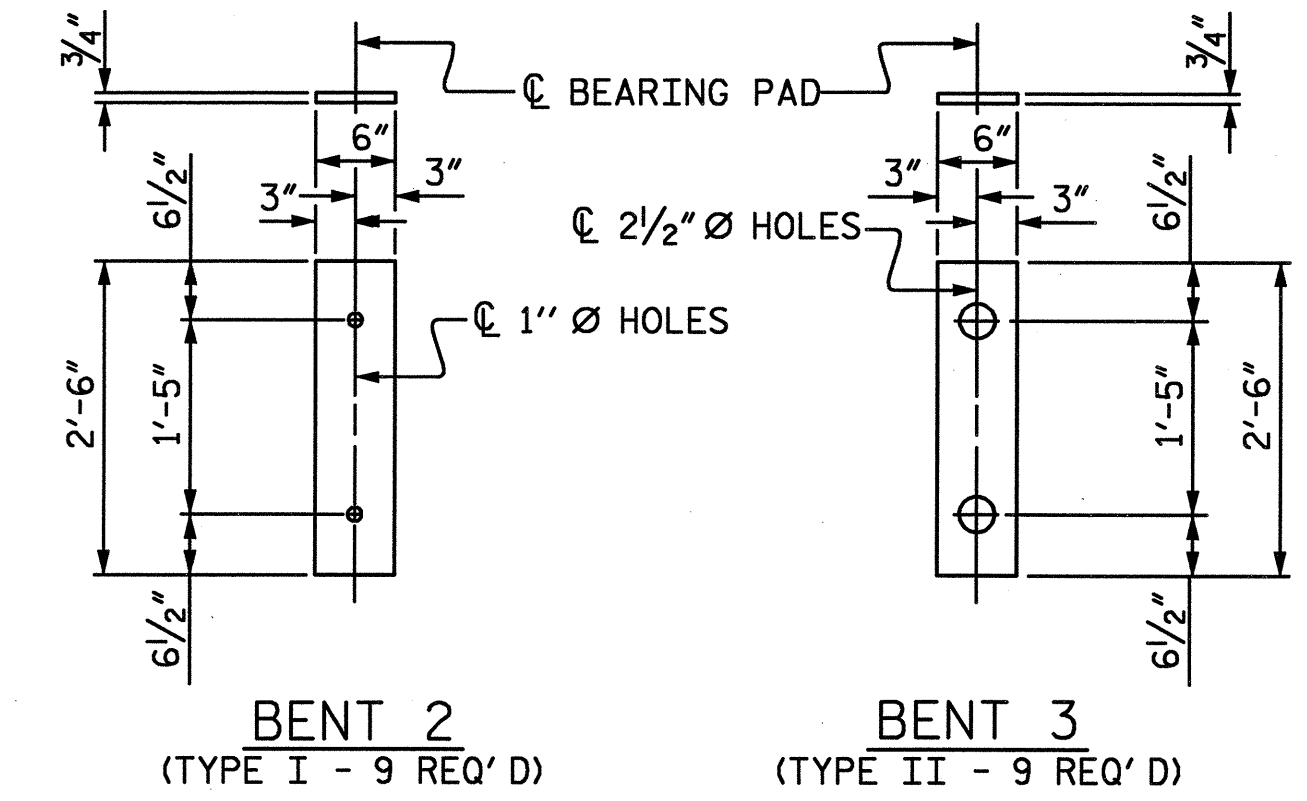

ELASTOMERIC BEARING DETAILS

SUPERSTRUCTURE REINFORCING STEEL LENGTHS ARE BASED ON THE FOLLOWING MINIMUM SPLICE LENGTHS

BAR SIZE	SUPERSTRUCTURE EXCEPT APPROACH SLABS, PARAPET AND BARRIER RAIL		APPROACH SLABS		PARAPET AND BARRIER RAIL
	EPOXY COATED	UNCOATED	EPOXY COATED	UNCOATED	
#4	2'-0"	1'-9"	2'-0"	1'-9"	2'-9"
#5	2'-6"	2'-2"	2'-6"	2'-2"	3'-5"
#6	3'-0"	2'-7"	3'-10"	2'-7"	4'-4"
#7	5'-3"	3'-6"			
#8	6'-10"	4'-7"			

PROJECT NO. B-5021

ROBESON COUNTY

BRIDGE: 151

SHEET 4 OF 4

STATE OF NORTH CAROLINA
DEPARTMENT OF TRANSPORTATION
RALEIGH

SUPERSTRUCTURE CONCRETE BRIDGE RAIL DETAILS

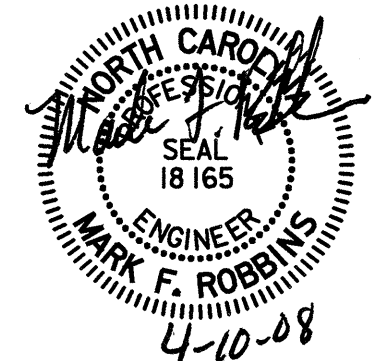

REVISIONS

NO.	BY:	DATE:	NO.	BY:	DATE:
1			3		
2			4		

SHEET NO. S-5
TOTAL SHEETS 62

DRAWN BY: TRL DATE: 1-08
CHECKED BY: TBQ DATE: 3-08

D-1809.5
STV / Ralph Whitehead Associates, Inc.
1000 West Morehead St., Ste. 200
Charlotte, NC 28208

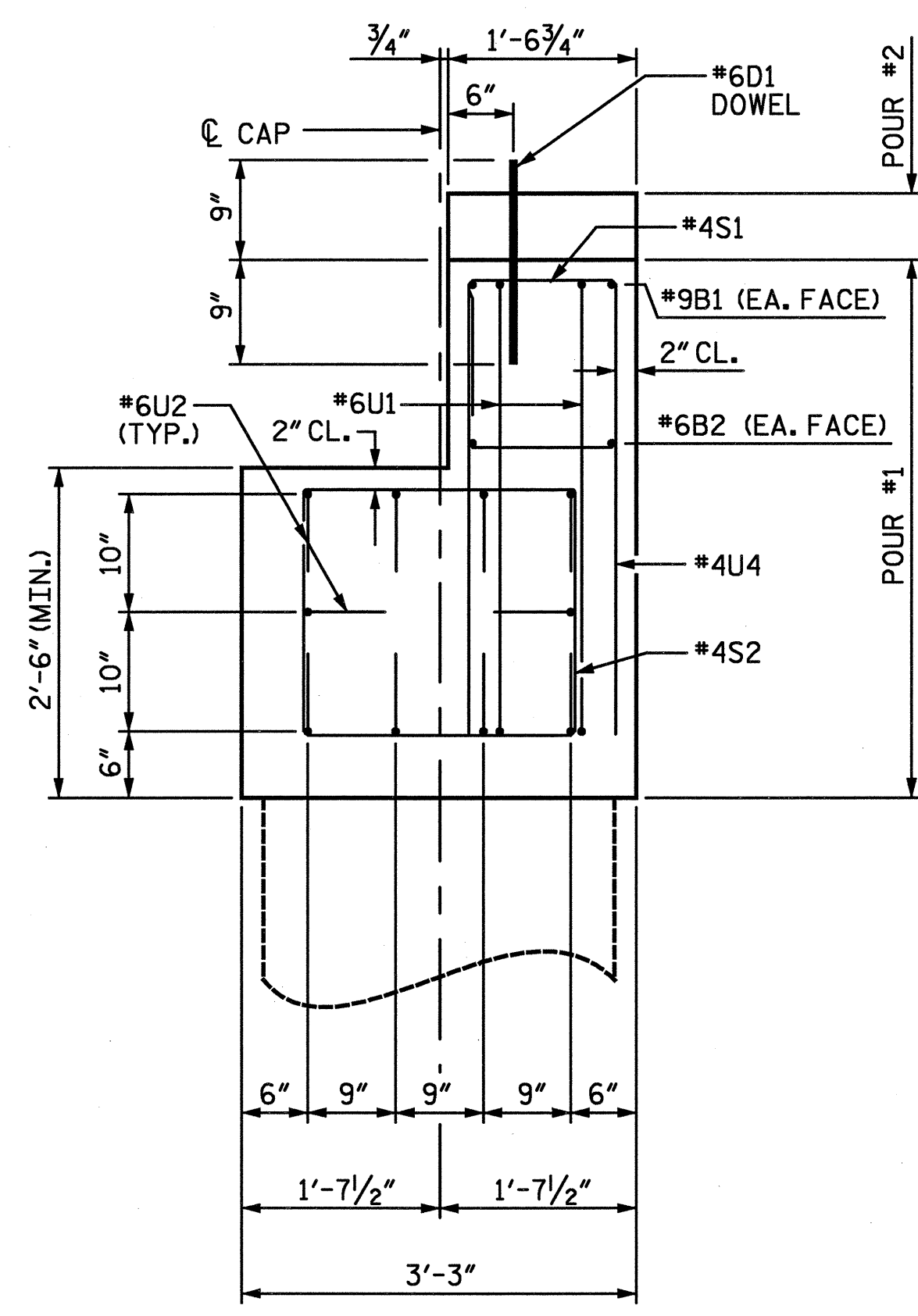

SECTION A-A

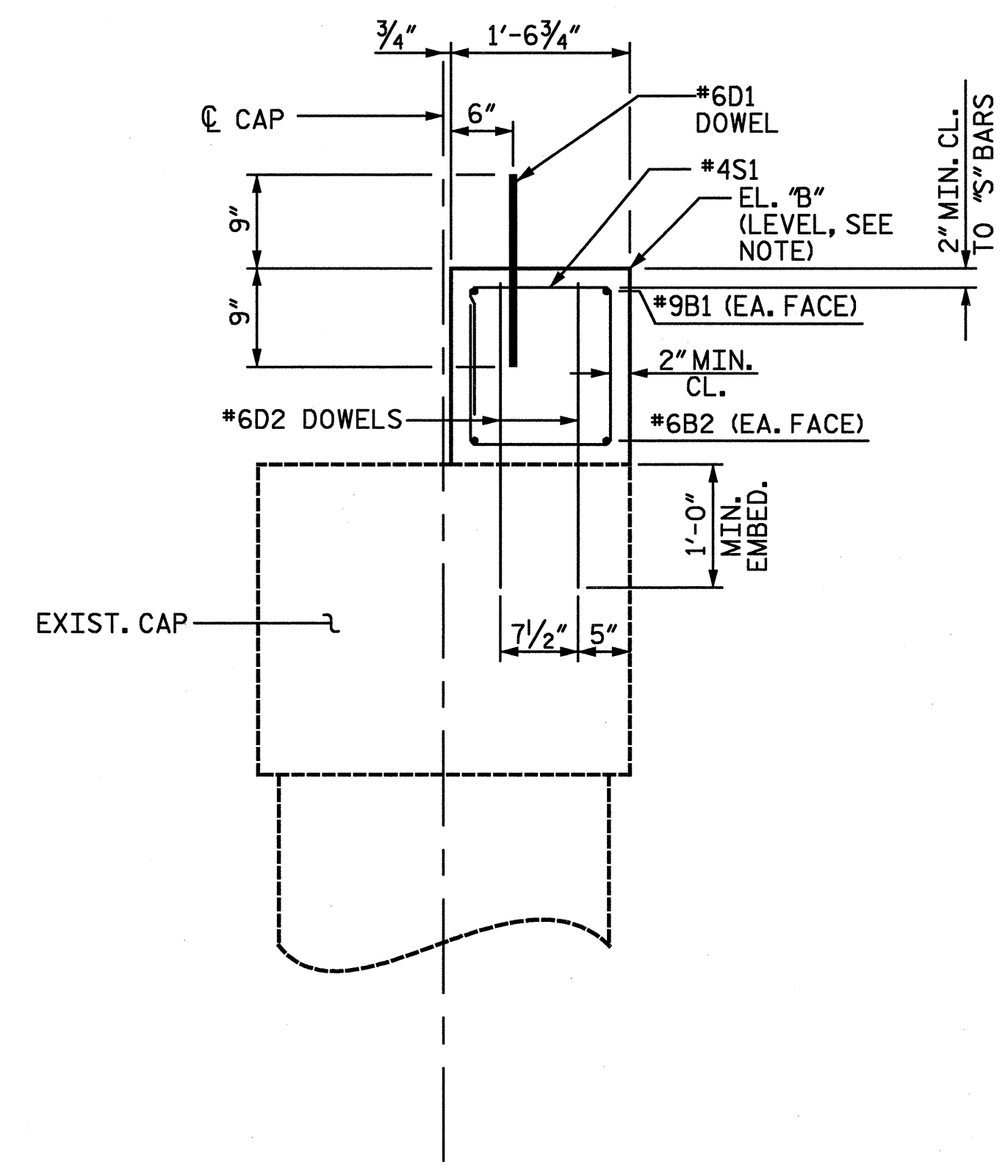

SECTION B-B

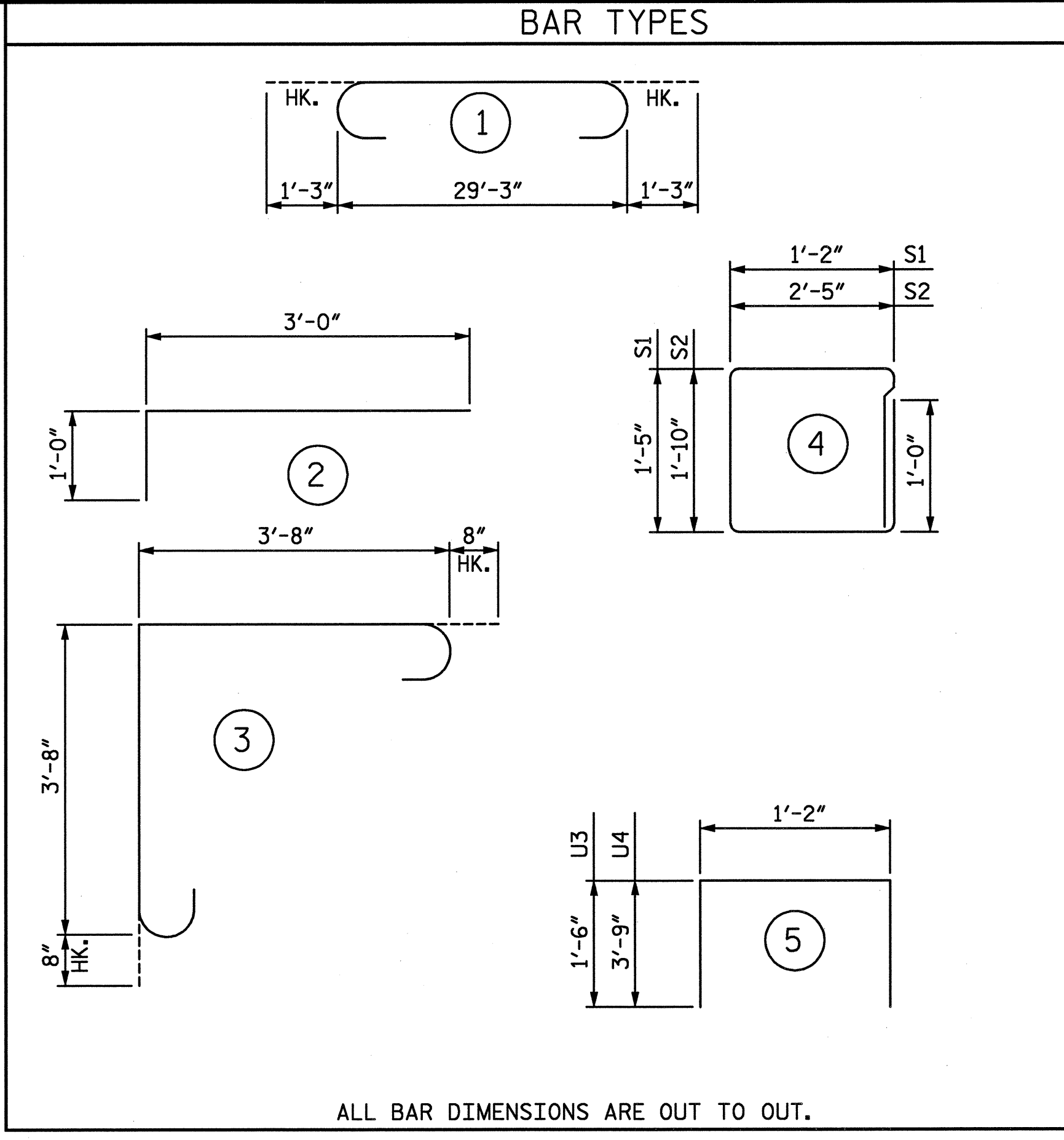

BAR TYPES

BILL OF MATERIAL

BENT 1					
BAR	NO.	SIZE	TYPE	LENGTH	WEIGHT
B1	2	9	①	31'-9"	216
B2	2	6	STR.	29'-3"	88
D1	18	6	STR.	1'-6"	41
D2	25	6	STR.	2'-0"	75
S1	30	4	④	6'-2"	124
S2	6	4	④	9'-6"	38
U1	4	6	⑤	8'-8"	52
U2	20	6	②	4'-0"	120
U3	4	4	⑤	4'-2"	11
U4	6	4	⑤	8'-8"	35
REINFORCING STEEL					LBS. 800
CLASS AA CONCRETE BREAKDOWN					
POUR 1 (CAP)				CY	4.5
POUR 2 (LATERAL GUIDE)				CY	0.1
TOTAL					CY 4.6

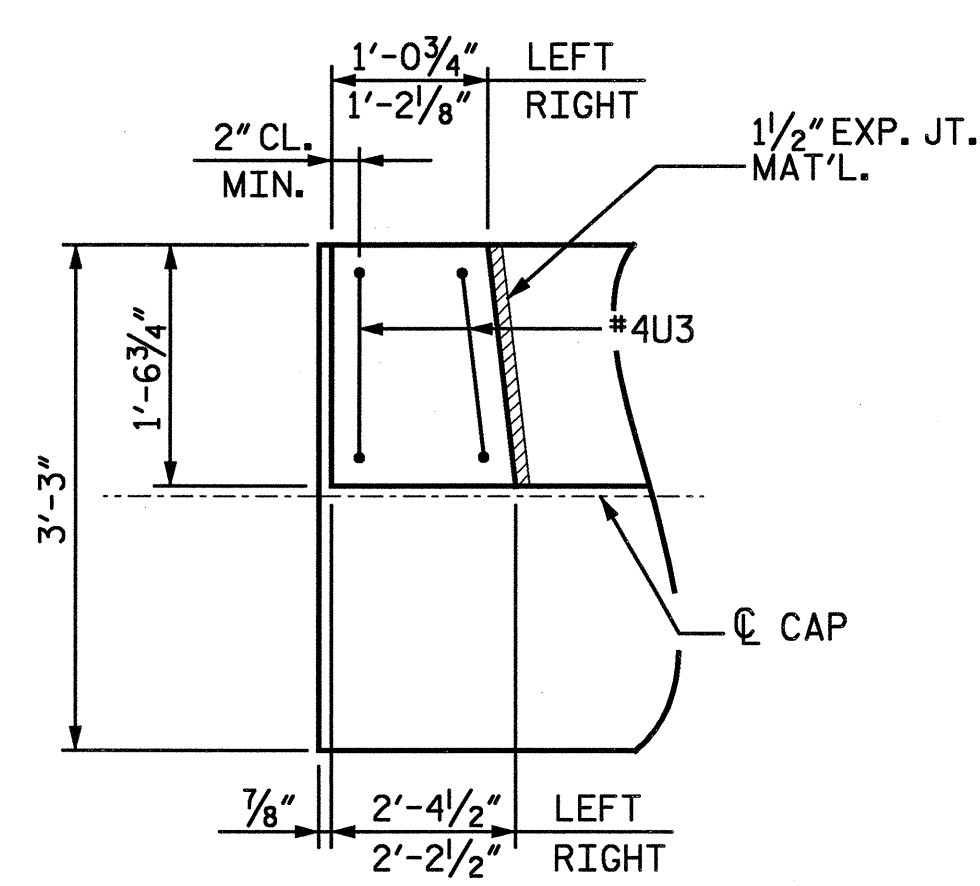

PLAN

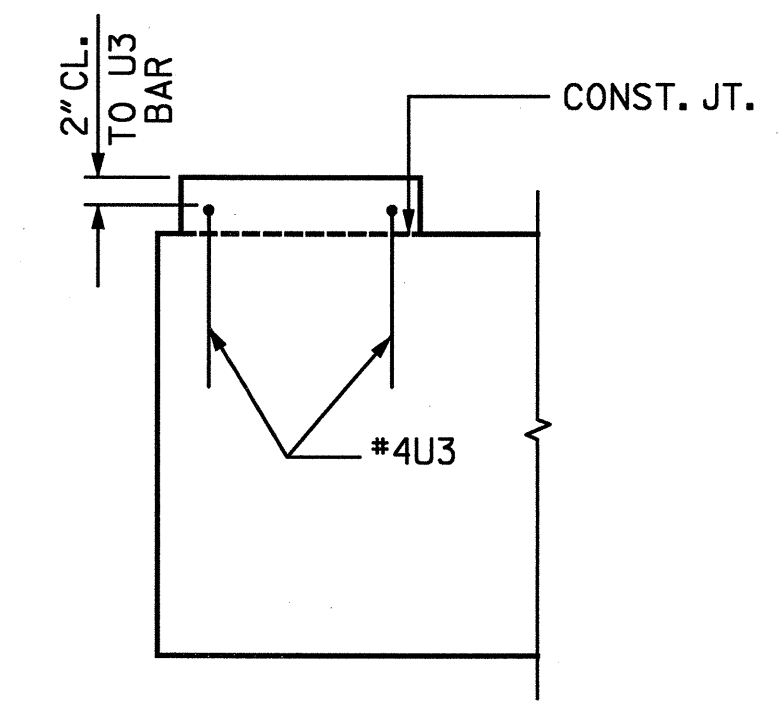

ELEVATION

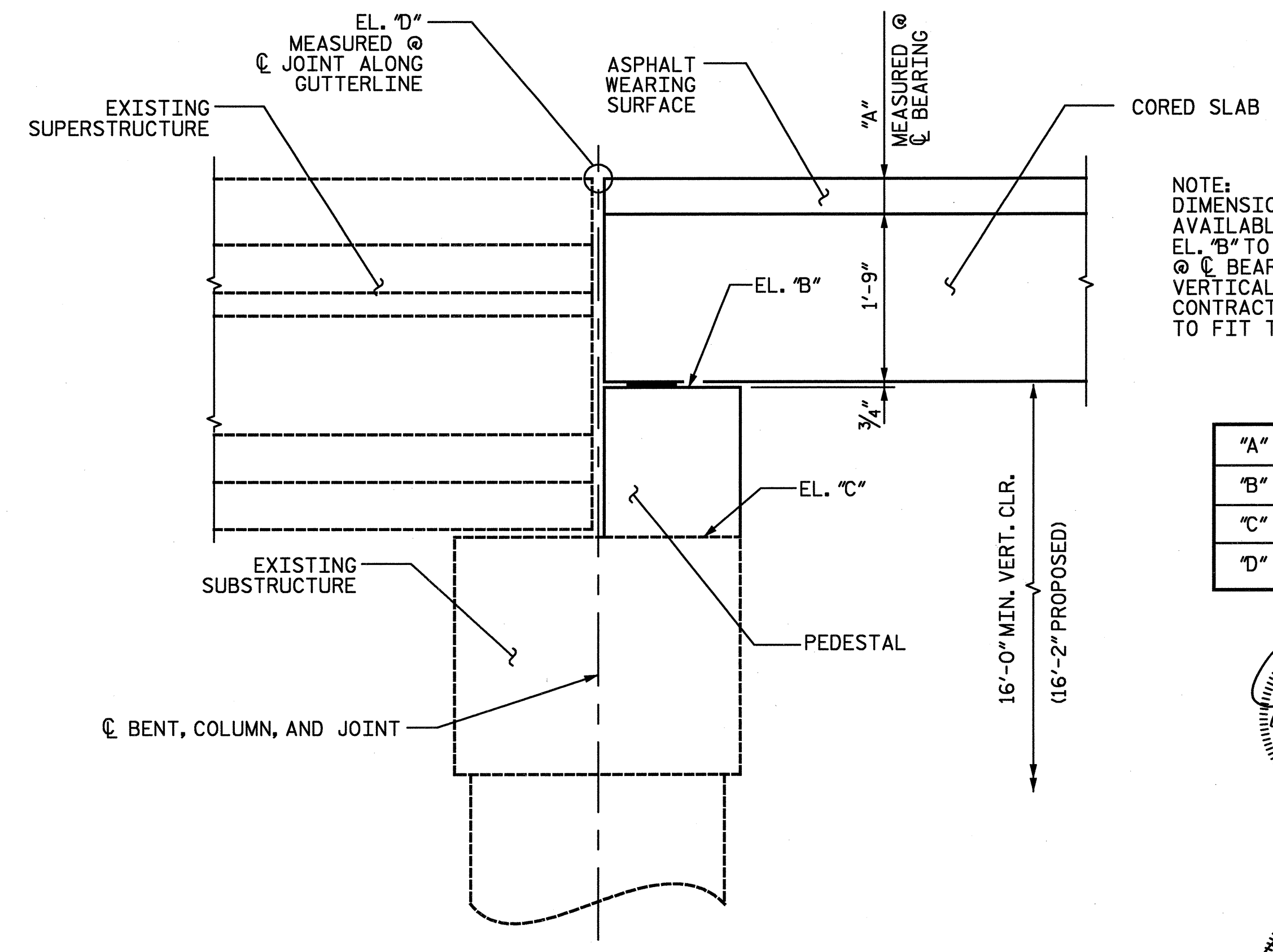

NOTE: DIMENSIONS AND ELEVATIONS SHOWN ARE FROM BEST INFORMATION AVAILABLE. CONTRACTOR SHALL MAKE ADJUSTMENTS TO PEDESTAL EL. "B" TO MAINTAIN 3/2" (4 1/2" MAX.) ASPHALT WEARING SURFACE @ C BEARING, MATCH EL. "D", AND TO MAINTAIN THE 16'-0" MIN. VERTICAL CLEARANCE. IF ANY ELEVATIONS ARE MODIFIED, THE CONTRACTOR IS RESPONSIBLE FOR ADJUSTING THE REINFORCING TO FIT THE PEDESTAL HEIGHT.

"A"	3 1/2"
"B"	164.64
"C"	162.80
"D"	166.75

PROJECT NO. B-5021
 ROBESON COUNTY
 BRIDGE: 151
 SHEET 2 OF 2

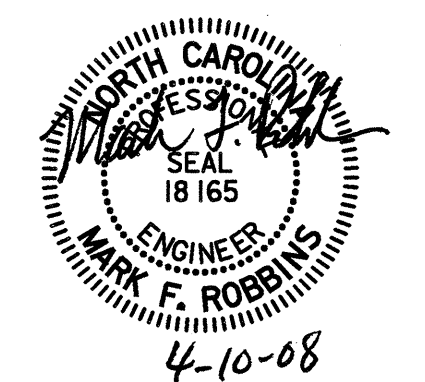
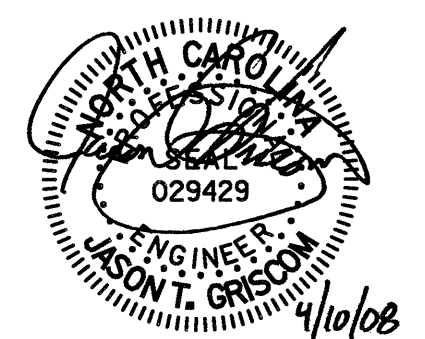

STATE OF NORTH CAROLINA
 DEPARTMENT OF TRANSPORTATION
 RALEIGH

SUBSTRUCTURE
 BENT 1

DRAWN BY: TRL DATE: 1-08
 CHECKED BY: TBQ DATE: 3-08

D-1809.7
 STV / Ralph Whitehead Associates, Inc.
 1000 West Morehead St., Ste. 200
 Charlotte, NC 28208

REVISIONS						SHEET NO.
NO.	BY:	DATE:	NO.	BY:	DATE:	S-7
1			3			TOTAL SHEETS 62
2			4			

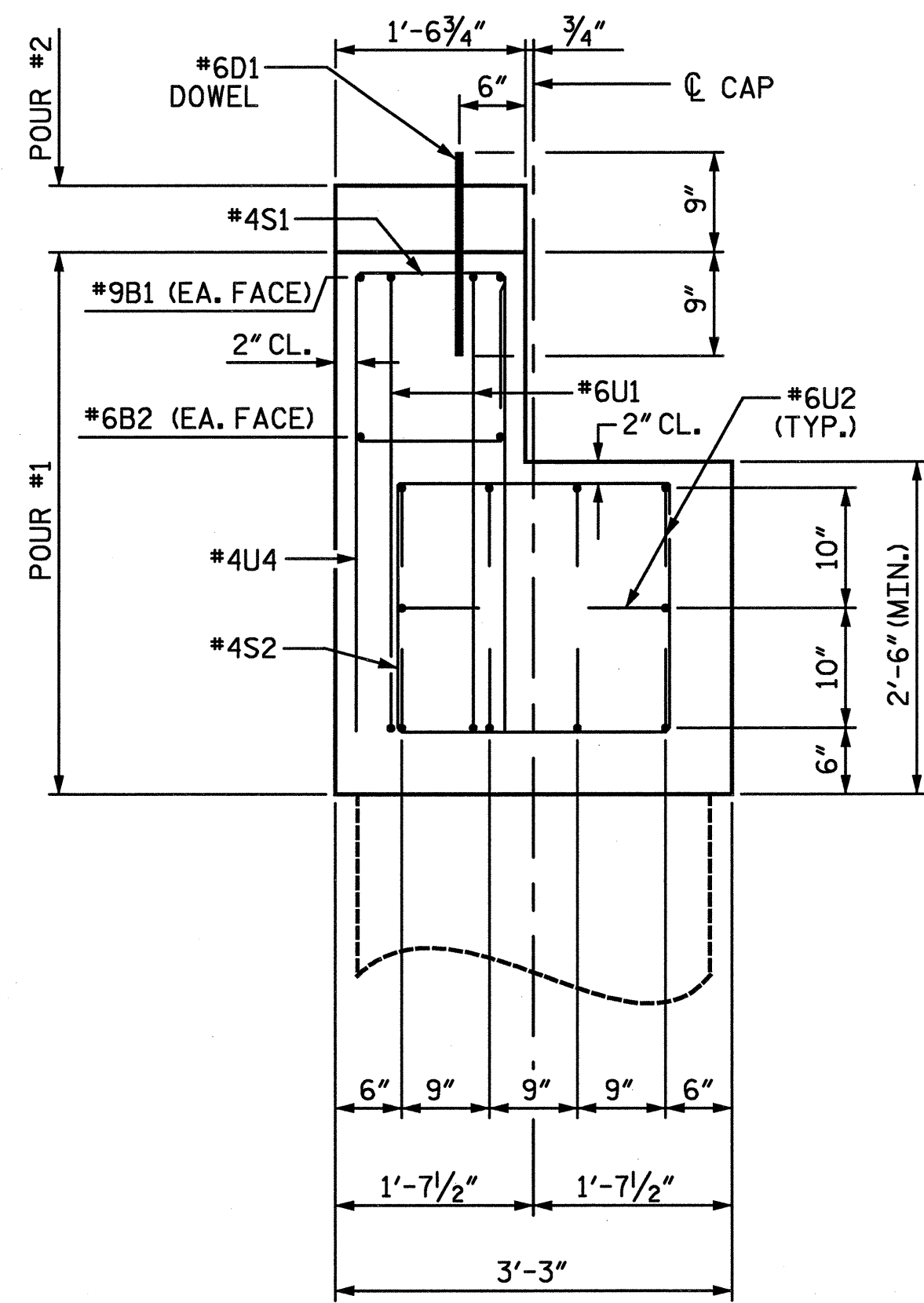

SECTION A-A

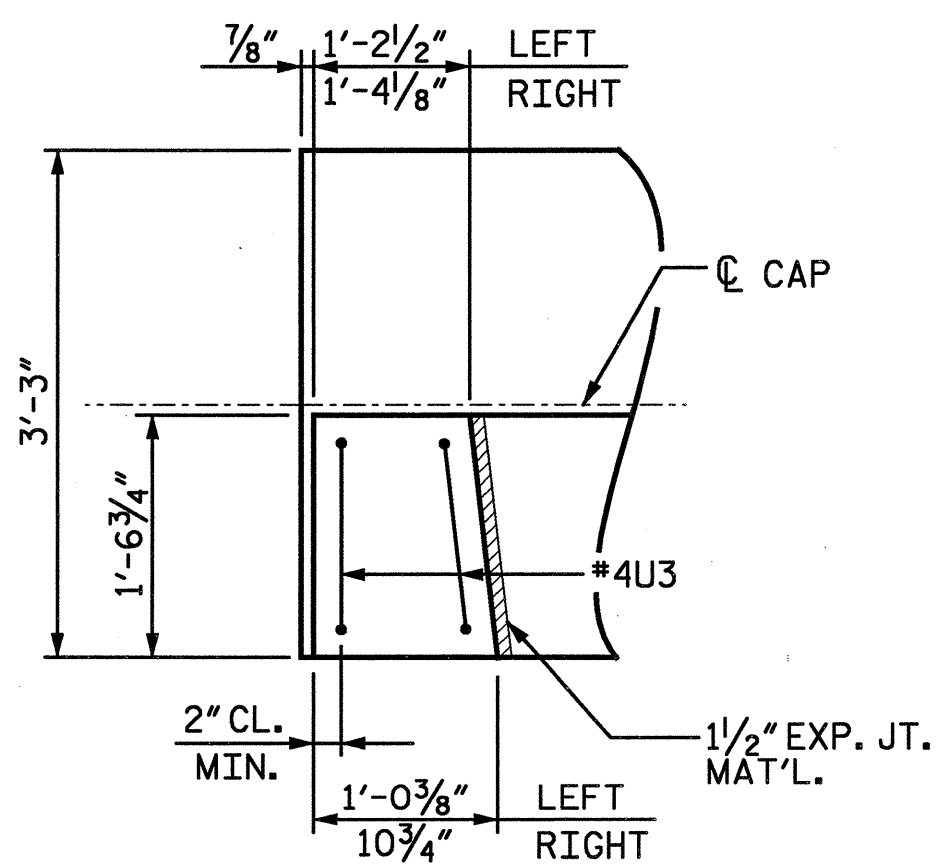

PLAN

LATERAL GUIDE DETAILS

(LEFT SIDE SHOWN, RIGHT SIDE SIMILAR)

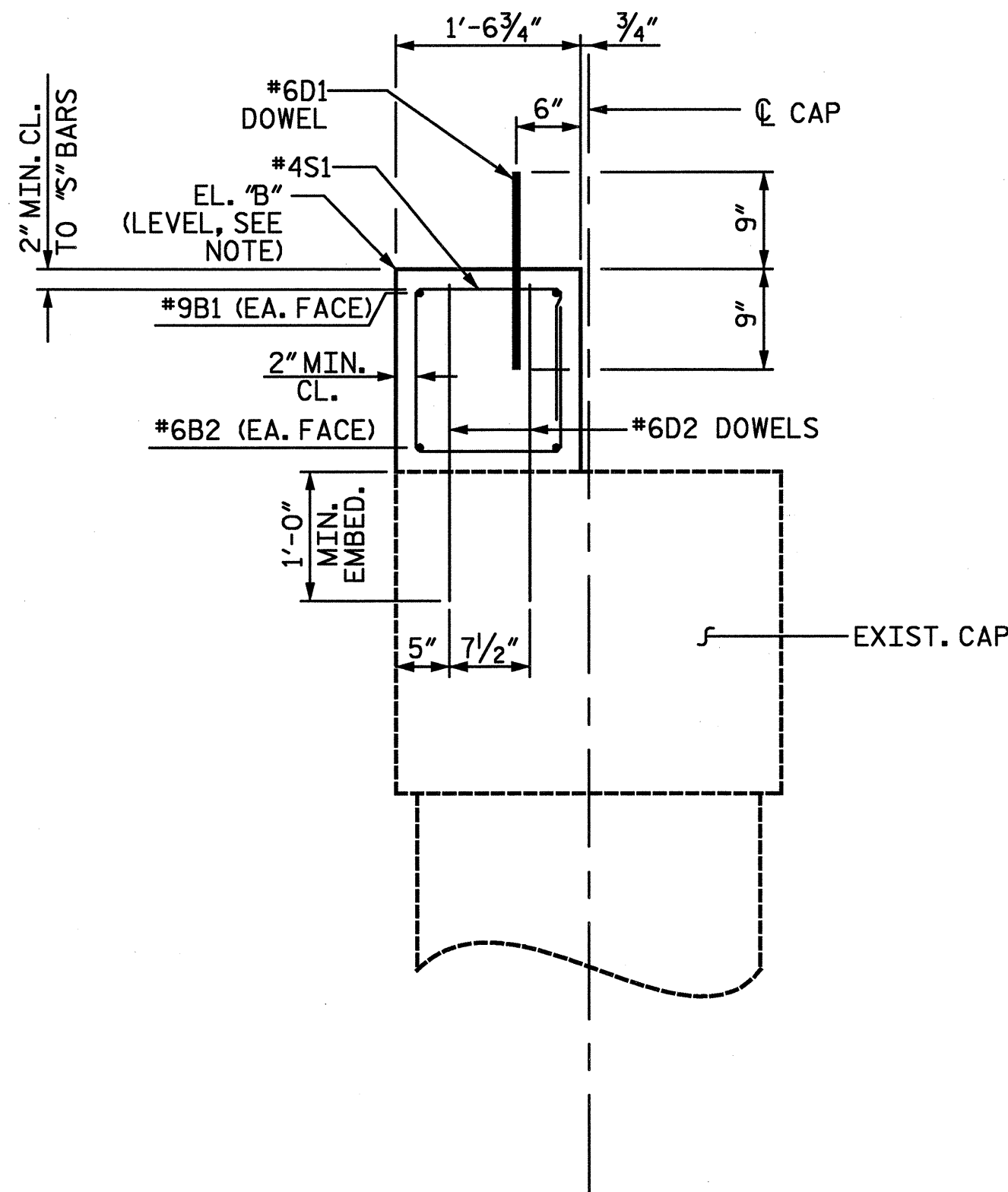

SECTION B-B

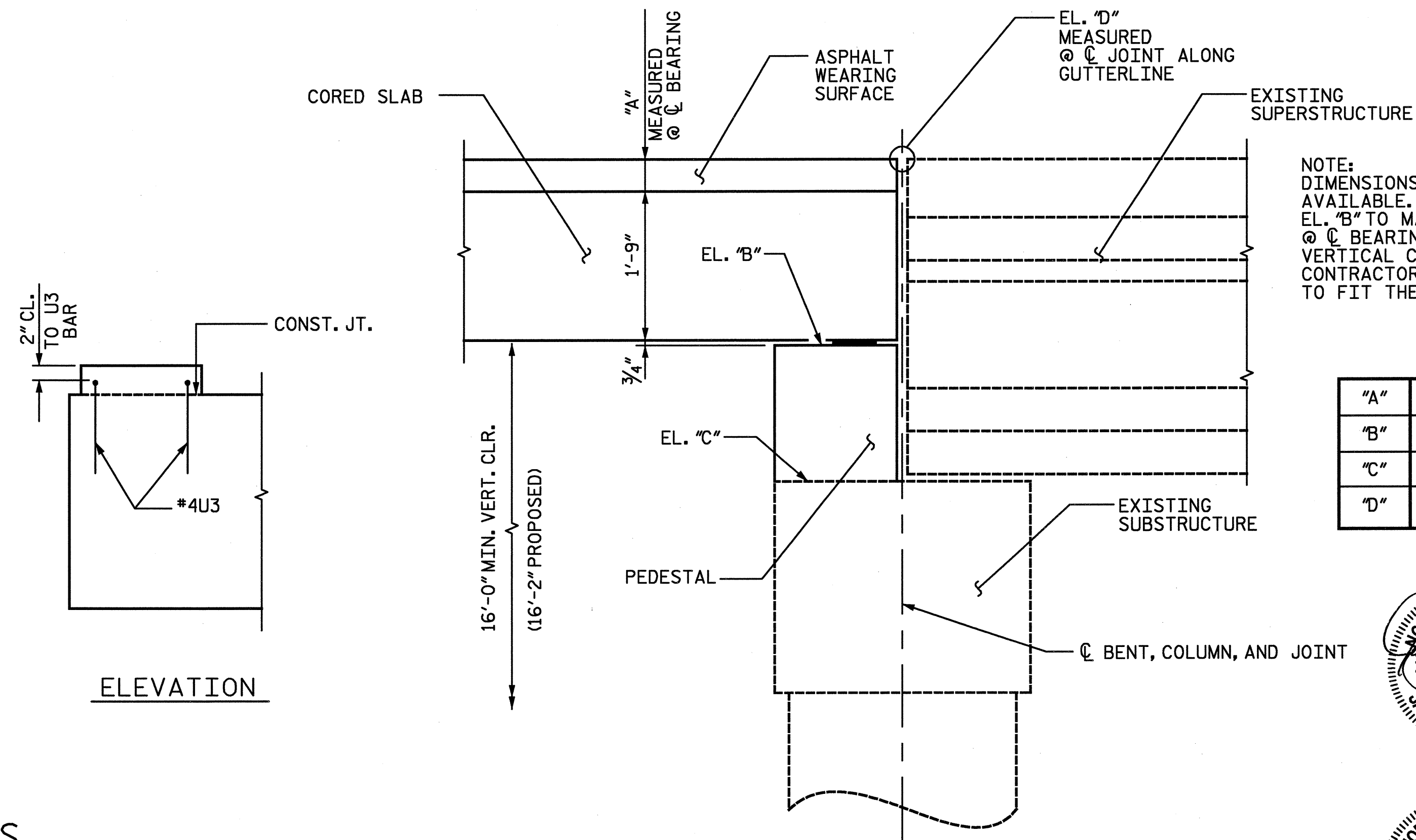

ELEVATION

PEDESTAL HEIGHT

NOTE: DIMENSIONS AND ELEVATIONS SHOWN ARE FROM BEST INFORMATION AVAILABLE. CONTRACTOR SHALL MAKE ADJUSTMENTS TO PEDESTAL EL. "B" TO MAINTAIN 3/2" (4 1/2" MAX.) ASPHALT WEARING SURFACE @ CL. BEARING, MATCH EL. "D", AND TO MAINTAIN THE 16'-0" MIN. VERTICAL CLEARANCE. IF ANY ELEVATIONS ARE MODIFIED, THE CONTRACTOR IS RESPONSIBLE FOR ADJUSTING THE REINFORCING TO FIT THE PEDESTAL HEIGHT.

"A"	3 1/2"
"B"	164.76
"C"	163.07
"D"	166.87

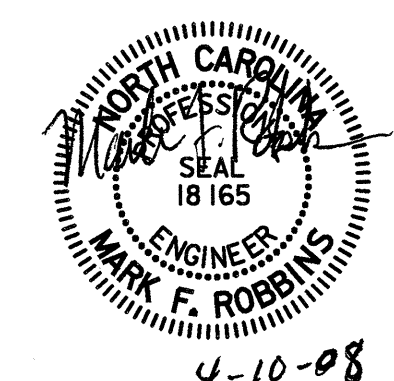
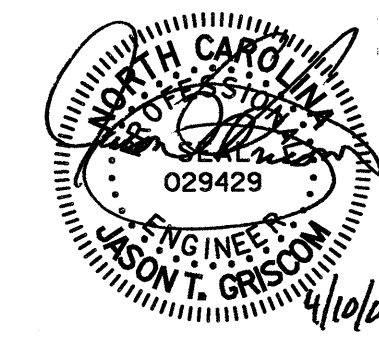

BAR TYPES

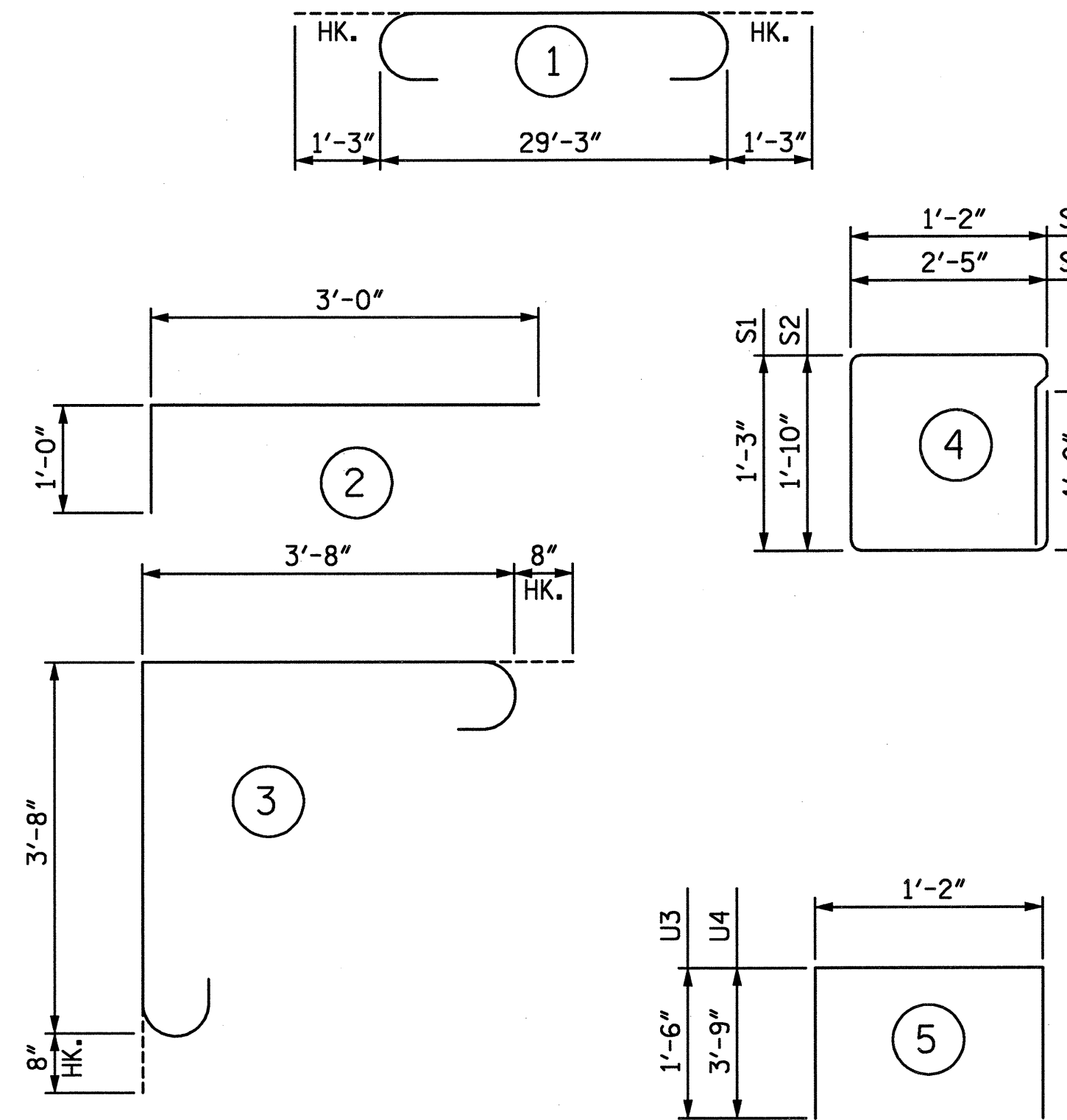

ALL BAR DIMENSIONS ARE OUT TO OUT.

BILL OF MATERIAL

BENT 2					
BAR	NO.	SIZE	TYPE	LENGTH	WEIGHT
B1	2	9	①	31'-9"	216
B2	2	6	STR.	29'-3"	88
D1	18	6	STR.	1'-6"	41
D2	25	6	STR.	2'-0"	75
S1	30	4	④	5'-10"	117
S2	6	4	④	9'-6"	38
U1	4	6	⑤	8'-8"	52
U2	20	6	②	4'-0"	120
U3	4	4	⑤	4'-2"	11
U4	6	4	⑤	8'-8"	35
REINFORCING STEEL					LBS. 793
CLASS AA CONCRETE BREAKDOWN					
POUR 1 (CAP)				CY	4.3
POUR 2 (LATERAL GUIDE)				CY	0.1
TOTAL					CY 4.4

PROJECT NO. B-5021
ROBESON COUNTY
BRIDGE: 151

SHEET 2 OF 2

STATE OF NORTH CAROLINA
DEPARTMENT OF TRANSPORTATION
RALEIGH

SUBSTRUCTURE
BENT 2

REVISIONS

NO.	BY:	DATE:	NO.	BY:	DATE:
1			3		
2			4		

SHEET NO.	
5-9	TOTAL SHEETS
67	

DRAWN BY: TRL DATE: 1-08
CHECKED BY: TBQ DATE: 3-08

D-1809.9

STV / Ralph Whitehead Associates, Inc.
1000 West Morehead St., Ste. 200
Charlotte, NC 28208

NOTES

FOR LATEX MODIFIED CONCRETE, SEE SPECIAL PROVISIONS.
 FOR REPAIR OF BRIDGE 54 DECK WITH LATEX MODIFIED CONCRETE, SEE SPECIAL PROVISIONS.
 FOR FALSEWORK AND FORMWORK SEE SPECIAL PROVISIONS.
 FOR MAINTENANCE AND PROTECTION OF TRAFFIC BENEATH BRIDGE, SEE SPECIAL PROVISIONS.
 FOR SUBMITTAL OF WORKING DRAWINGS, SEE SPECIAL PROVISIONS.
 FOR CRANE SAFETY, SEE SPECIAL PROVISIONS.
 ALL DIMENSIONS IN THESE PLANS ARE BASED ON BEST AVAILABLE INFORMATION. CONTRACTOR SHALL VERIFY DIMENSION IN FIELD PRIOR TO CONSTRUCTION AND ANY FABRICATION. CONTRACTOR SHALL NOTIFY THE ENGINEER OF DISCREPANCIES SUCH THAT ANY NECESSARY ADJUSTMENTS BE MADE BY THE CONTRACTOR.
 ALL STRUCTURAL STEEL SHALL BE ASTM A36 MIN.
 ALL WELDING SHALL BE IN ACCORDANCE WITH CURRENT AWS SPECIFICATIONS.

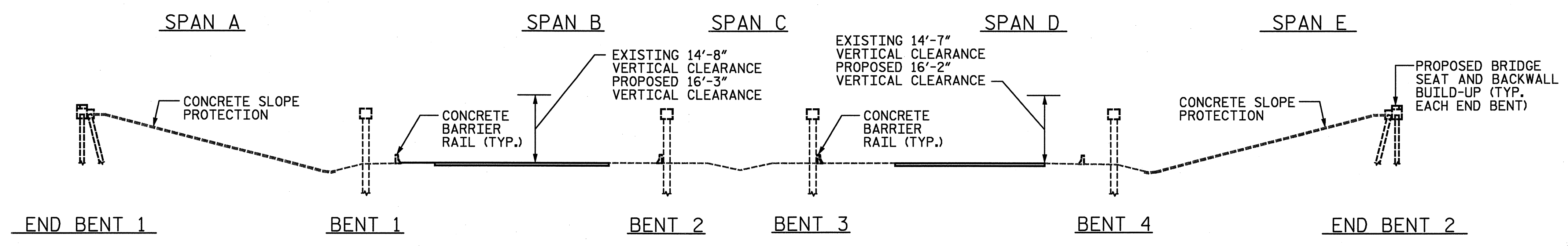

ELEVATION
 (SECTIONS AT BENTS AND END BENTS ARE AT RIGHT ANGLES)

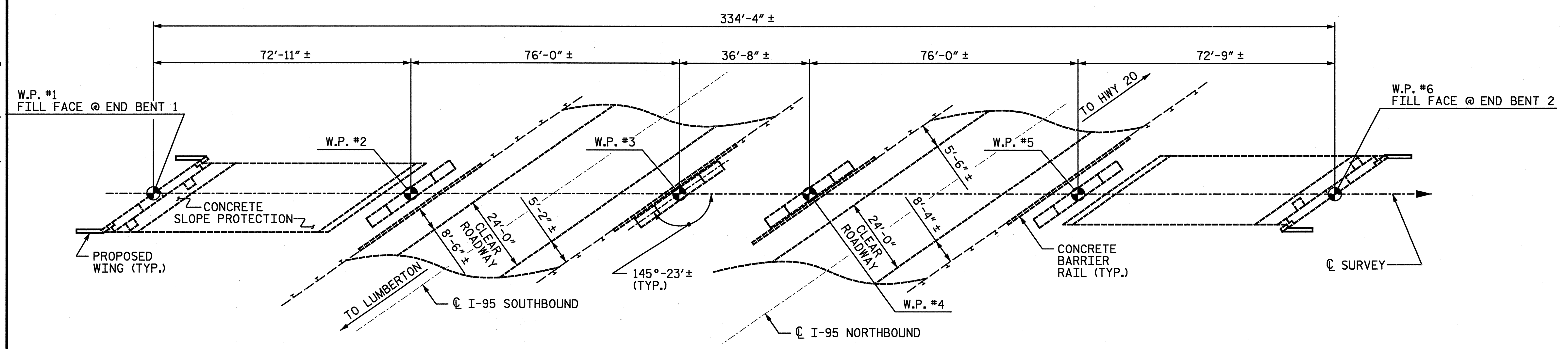

PLAN

TOTAL BILL OF MATERIAL

	PARTIAL REMOVAL OF EXISTING STRUCTURE	BRIDGE FLOOR GROOVING	CLASS AA CONCRETE	BRIDGE APPROACH SLABS	REINFORCING STEEL	STRUCTURAL STEEL *	CLASS I, SURFACE PREPARATION	CLASS II, SURFACE PREPARATION	LATEX MODIFIED CONCRETE OVERLAY	PLACING AND FINISHING OF LATEX MODIFIED CONCRETE OVERLAY	EPOXY RESIN INJECTION	EPOXY MORTAR REPAIRS	EVAZOTE JOINT SEALS	BRIDGE JACKING
	LUMP SUM	SQ. FT.	CU. YDS.	LUMP SUM	LBS.	APPROX. LBS.	SQ. YDS.	SQ. YDS.	CU. YDS.	SQ. YDS.	LINEAR FT.	SQ. FT.	LUMP SUM	LUMP SUM
SUPERSTRUCTURE	LUMP SUM	8,965	5.0	LUMP SUM		9940	1036	82	35.1	1,010	20.0		LUMP SUM	LUMP SUM
END BENT 1	LUMP SUM		15.3		2391	67						2.0		
BENT 1											10.0	5.5		
BENT 2												1.0		
BENT 3											20.0	1.0		
BENT 4											10.0			
END BENT 2	LUMP SUM		15.3		2391	67								
TOTAL	LUMP SUM	8,965	35.6	LUMP SUM	4782	10,074	1036	82	35.1	1,010	60.0	9.5	LUMP SUM	LUMP SUM

* INCLUDES WEIGHT OF ANCHOR BOLTS

PROJECT NO. **B-5021**
 ROBESON COUNTY
 BRIDGE: **54**
 MODIFICATION OF BRIDGE NO. 54

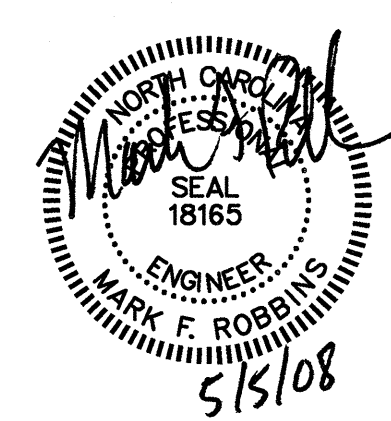
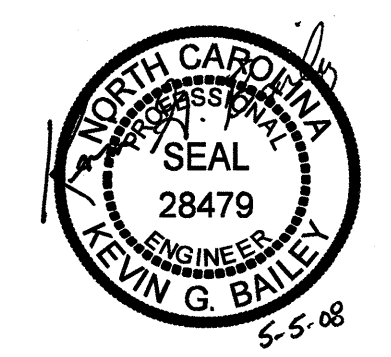

STATE OF NORTH CAROLINA
 DEPARTMENT OF TRANSPORTATION
 RALEIGH
 GENERAL DRAWING
 BRIDGE OVER I-95 ON
 US 301
 BETWEEN HWY 20 AND
 SR 1529

REVISIONS						SHEET NO.
NO.	BY:	DATE:	NO.	BY:	DATE:	TOTAL SHEETS
1	STV	5-08	3			62
2			4			

REVISION #1: REVISED PER REVIEW COMMENTS
 BY: TJT DATE: 5-08
 CH'KD BY: KGB DATE: 5-08

NOT TO SCALE

D-1809.10
 STV/Ralph Whitehead Associates, Inc.
 1000 West Morehead St., Ste. 200
 Charlotte, NC 28208

N:\PROJ\2513448\B5021\Roadway\Proj\Bridge 54\Structures\Station\Finals\plan & profile.dgn
 6:39:44 AM
 timothy.townsend 5/2/2008

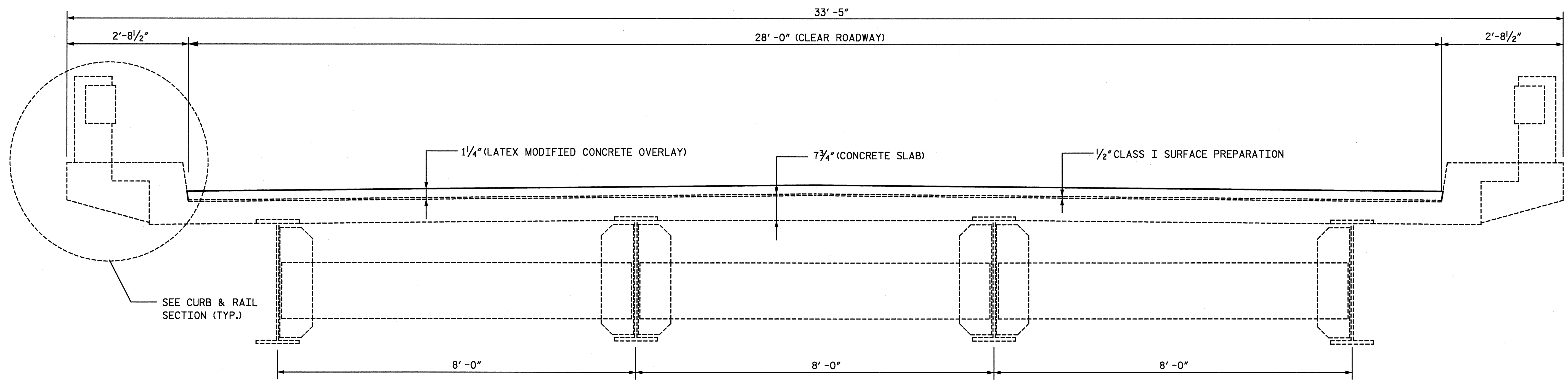

TYPICAL SECTION

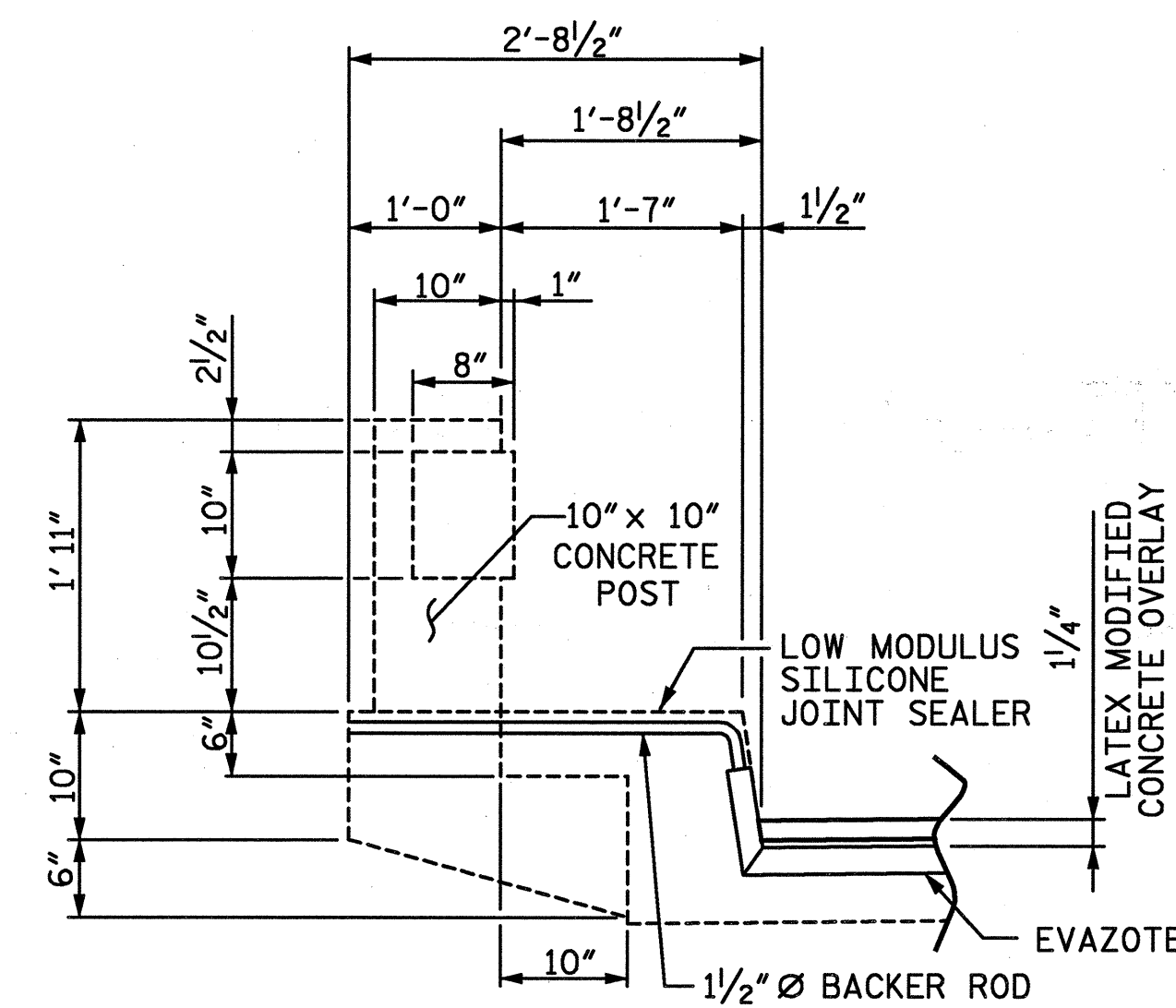

CURB AND RAIL SECTION *

* PER SIDE, THERE ARE 12 POSTS IN SPANS A, B, D & E AND 6 POSTS IN SPAN C. TOTAL RAIL LENGTH = 338'7" ± PER SIDE.

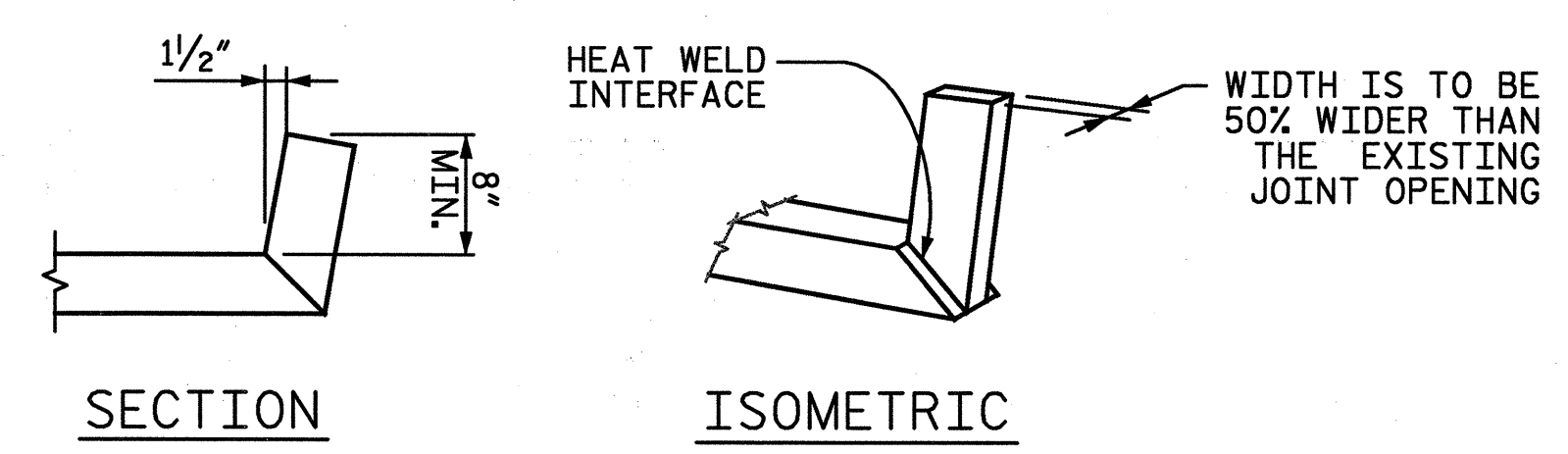

EVAZOTE JOINT DIRECTIONAL CHANGE DETAIL

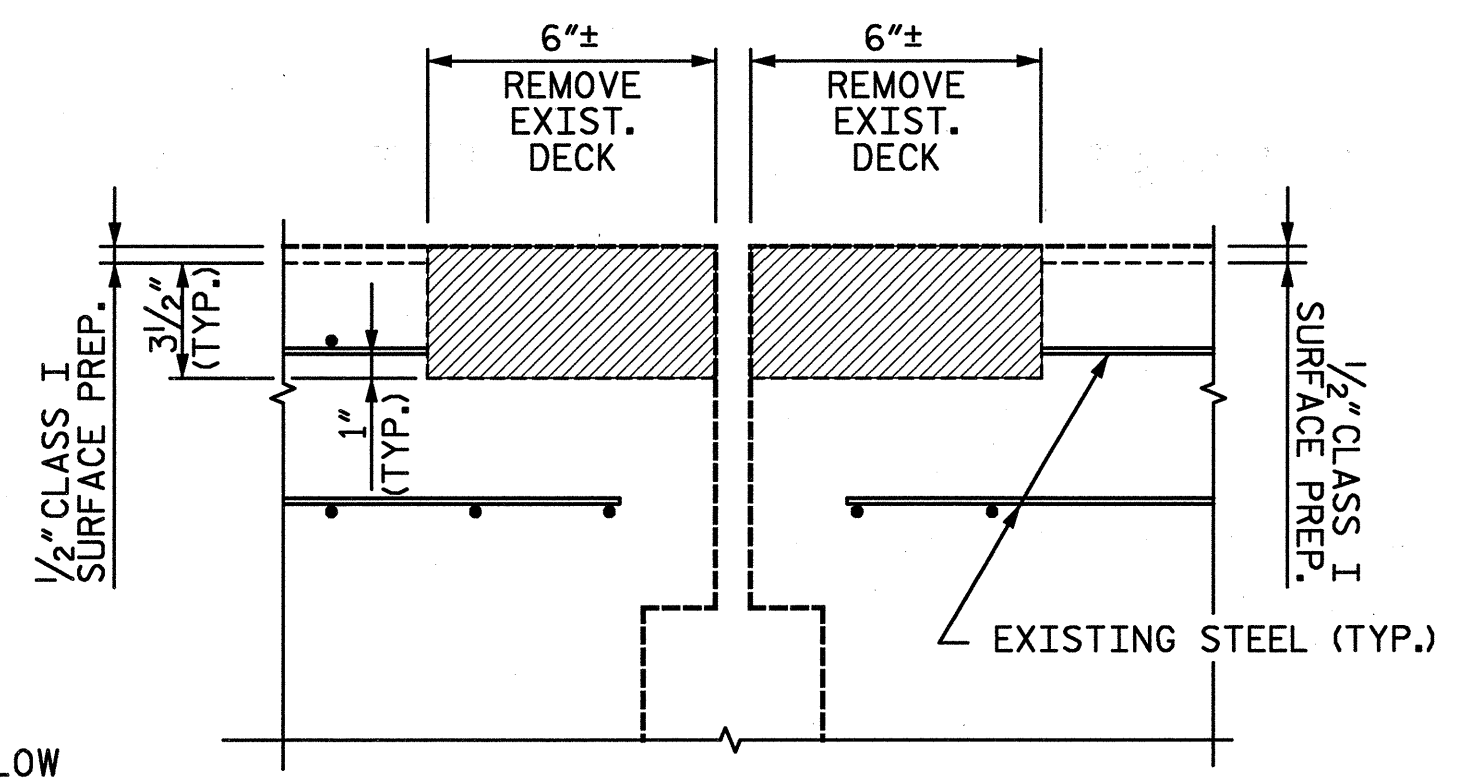

REMOVAL SECTION

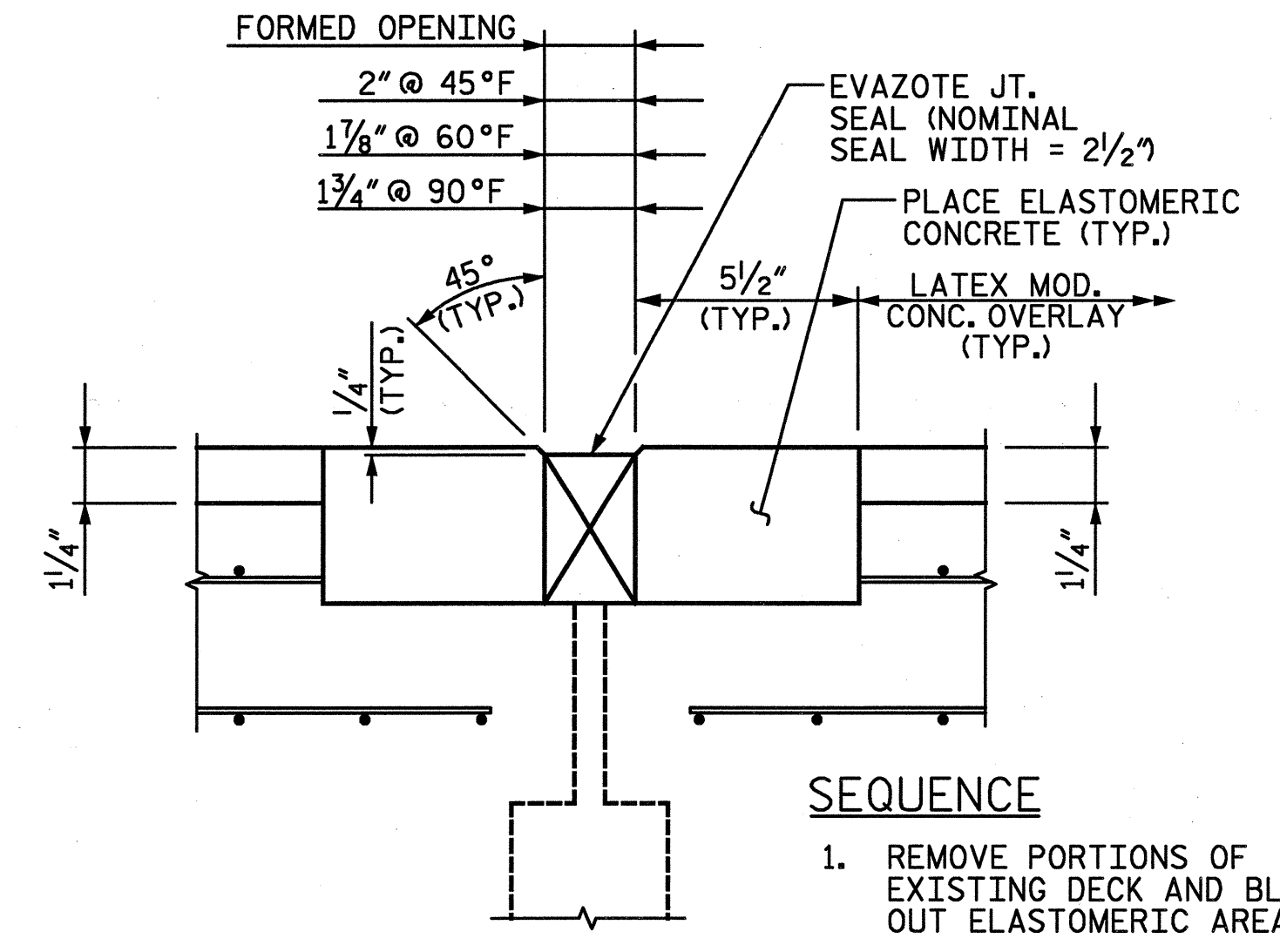

PROPOSED SECTION

- SEQUENCE
1. REMOVE PORTIONS OF EXISTING DECK AND BLOCK OUT ELASTOMERIC AREA.
 2. PLACE LATEX MODIFIED CONCRETE.
 3. FORM JOINT AND POUR ELASTOMERIC CONCRETE.
 4. REMOVE JOINT FORM.
 5. INSTALL EVAZOTE JOINT.

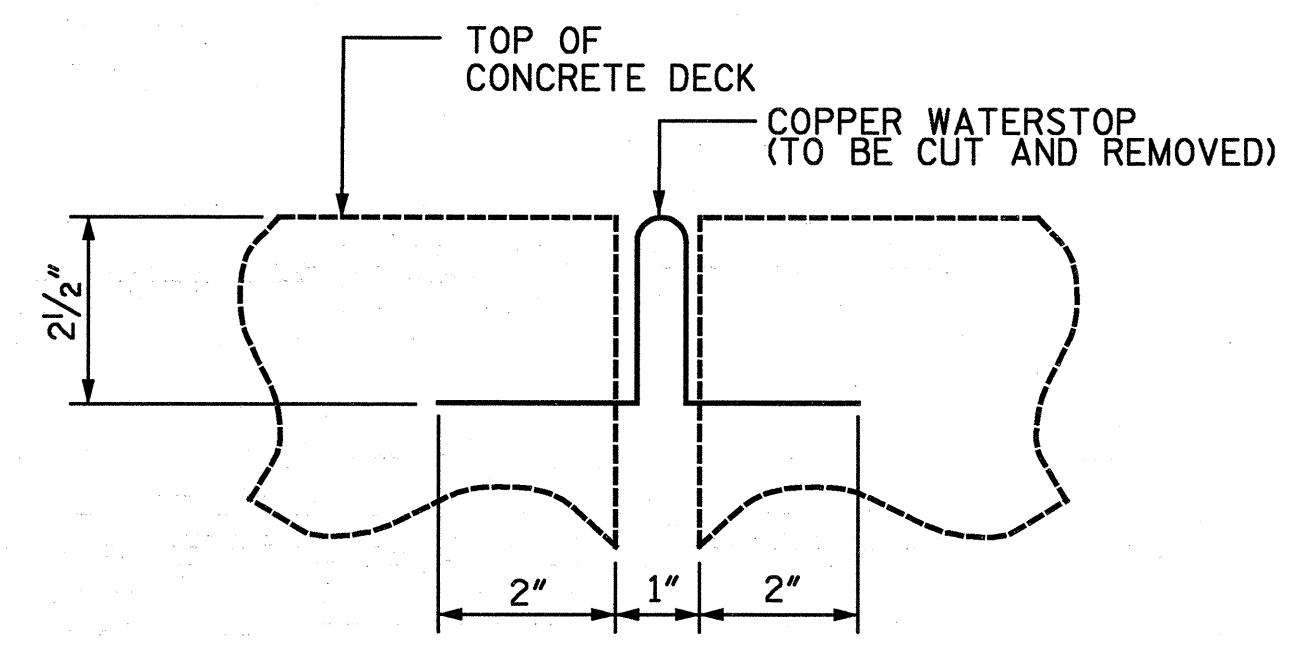

EXISTING EXPANSION JOINT DETAIL

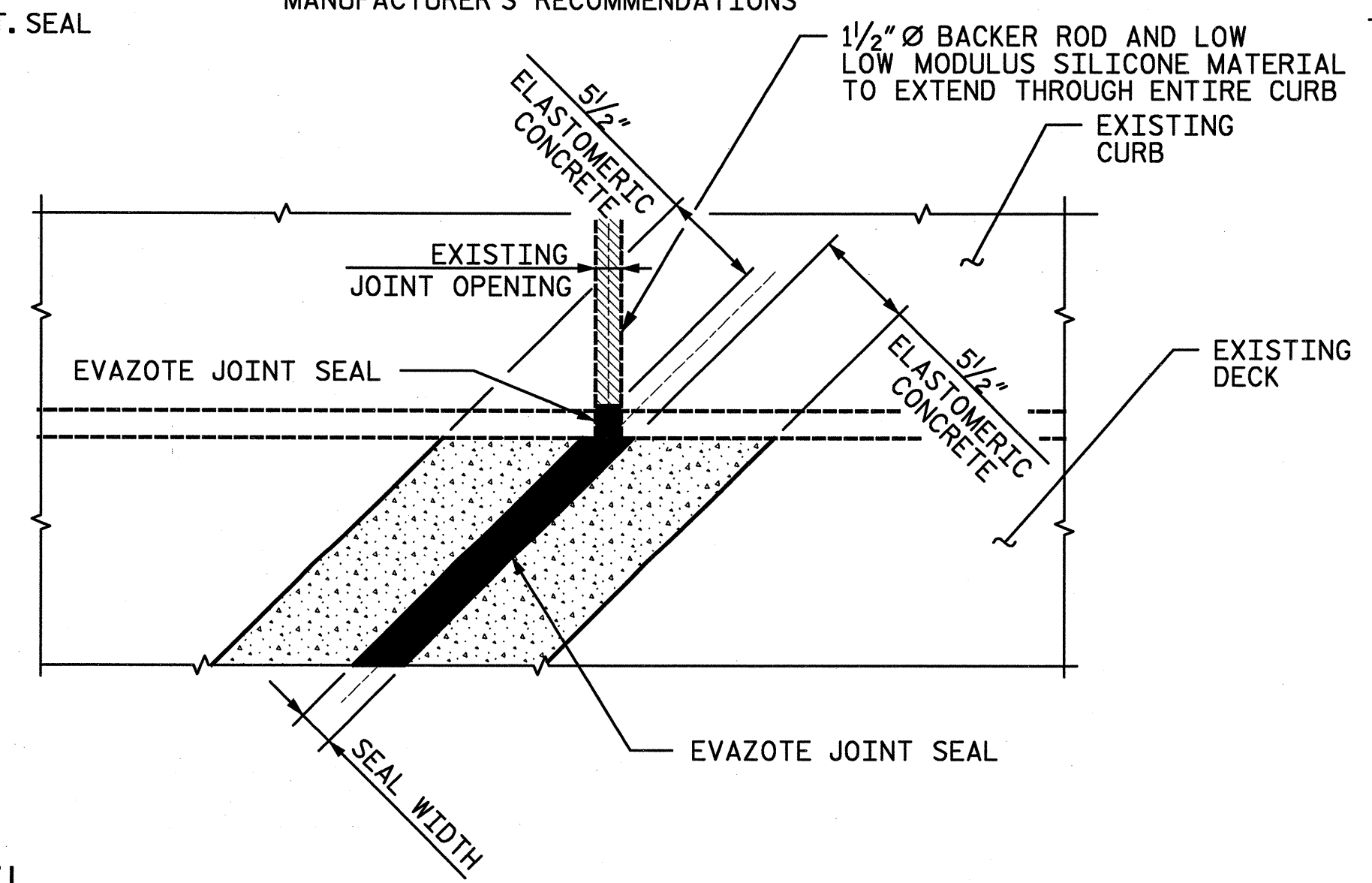

PLAN VIEW OF EVAZOTE JOINT @ GUTTERLINE

NOTES

1. FOR ELASTOMERIC CONCRETE, SEE SPECIAL PROVISIONS.
2. FOR EVAZOTE JOINT SEALS, SEE SPECIAL PROVISIONS.
3. PAYMENT FOR INSTALLATION OF THE 1/2" Ø BACKER ROD AND LOW MODULUS SILICONE JOINT SEALER SHALL BE CONSIDERED INCIDENTAL TO CONSTRUCTION OF THE BRIDGE.

JOINT REPAIR DETAIL

BILL OF MATERIAL	
BENT NO.	ELASTOMERIC CONCRETE (CU. FT.) *
1	17.9
2	17.9
3	17.9
4	17.9

* BASED ON MINIMUM BLOCKOUT SHOWN
 NOTE: SEE APPROACH SLAB FOR ELASTOMERIC CONCRETE AT END BENTS

PROJECT NO. **B-5021**
 ROBESON COUNTY
 BRIDGE: **54**

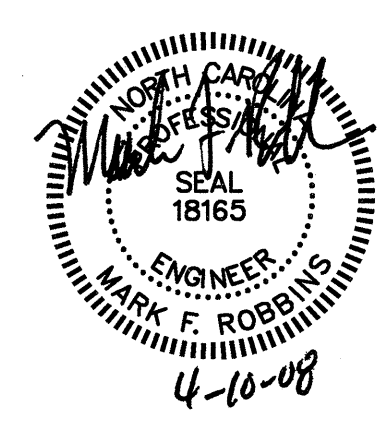
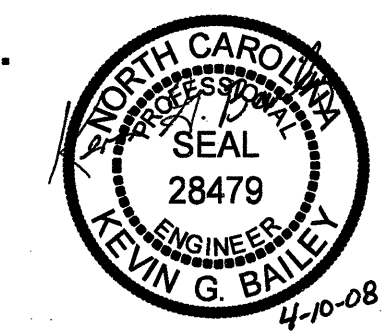

STATE OF NORTH CAROLINA
 DEPARTMENT OF TRANSPORTATION
 RALEIGH
 EXISTING SUPERSTRUCTURE
 TYPICAL SECTION

REVISIONS						SHEET NO.
NO.	BY:	DATE:	NO.	BY:	DATE:	
1			3			5-11
2			4			TOTAL SHEETS 62

NOT TO SCALE

D-1809.11
 STV / Ralph Whitehead Associates, Inc.
 1000 West Morehead St., Ste. 200
 Charlotte, NC 28208

4/10/2008 2:24:00 PM N:\PROJ\253448\B5021\Bridges\Finals\Typical Section.dgn timothy.townsend

N:\PROJ\2513448\B5021\Roadway\Proj\Bridg 54\Structures\Illustration\Finals\Bridg 54 Jacking.dgn
 6:38:48 AM
 5/2/2008
 timothy.townsend

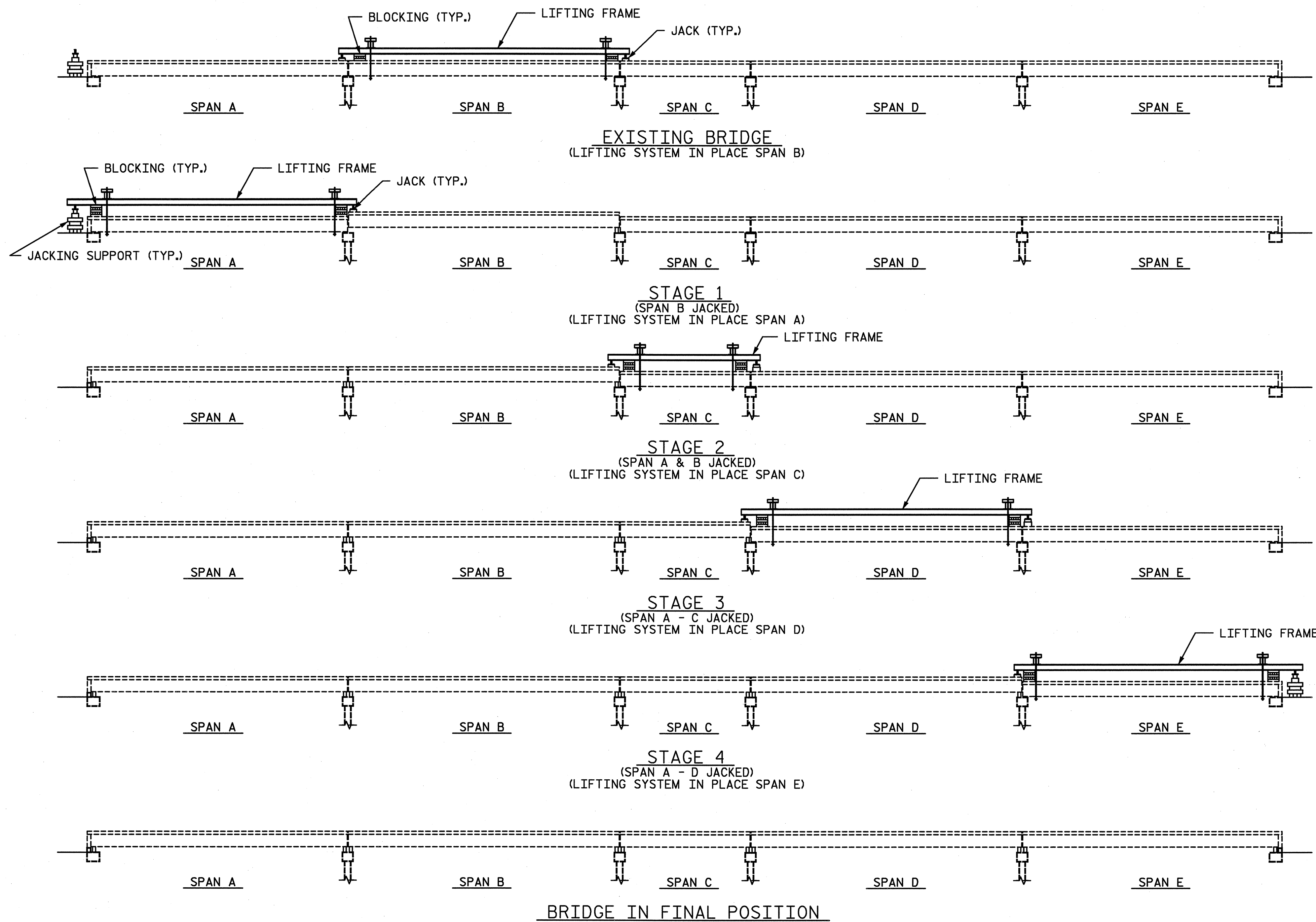

JACKING SEQUENCE FOR BRIDGE 54

NOTES:

1. THE CONTRACTOR SHALL JACK ALL BEAMS IN ANY ONE SPAN SIMULTANEOUSLY.
2. TRAFFIC SHALL NOT BE ALLOWED ON THE STRUCTURE UNTIL THE WORK REQUIRED BY THE CONTRACT DOCUMENTS IS COMPLETE.
3. PRIOR TO INSTALLING BEARING PEDESTALS AND NEW BEARINGS, CONTRACTOR SHALL MAKE ANY REPAIRS TO BENTS AS REQUIRED IN THE CONTRACT DOCUMENTS.
4. CONTRACTOR SHALL SUBMIT JACKING PLANS AND CALCULATIONS SEALED BY A PROFESSIONAL ENGINEER REGISTERED IN THE STATE OF NORTH CAROLINA FOR REVIEW AND APPROVAL PRIOR TO MATERIAL PURCHASE OR FABRICATION OF JACKING SYSTEM.
5. FOR ADDITIONAL INFORMATION ON JACKING SEE SPECIAL PROVISION "BRIDGE JACKING."
6. LIFTING FRAME SHALL EXTEND BEYOND THE LENGTH OF THE LIFTED SPAN AND PROVIDE BEARINGS AT THE SAME LOCATION AS THE ADJACENT GIRDER BEARINGS.
7. CONTRACTOR SHALL SHIM BRIDGE SPAN DURING JACKING SUCH THAT THE MAXIMUM UNSHIMMED LIFT IS 1".
8. CONTRACTOR SHALL PROVIDE SPAN LIFT POINTS AS CLOSE AS POSSIBLE TO THE FACE OF BENT CAP.
9. HYDRAULIC SYSTEM SHALL BE CONNECTED SUCH THAT ALL JACKS LIFT SIMULTANEOUSLY.
10. CONTRACTOR SHALL DESIGN LIFTING SYSTEM SUCH THAT HORIZONTAL POSITION OF THE LIFTED SPAN CAN BE MAINTAINED.

CONSTRUCTION SEQUENCE:

1. CONSTRUCT JACKING SUPPORT AT END BENT. CONTRACTOR SHALL MAKE SURE CURTAIN WALL IS FULLY DETACHED FROM END BENT CAP, WINGS, AND FILL.
2. CONSTRUCT THE LIFTING FRAME (FOR SPAN B) MAKING SURE SYSTEM IS LEVEL. INSTALL BLOCKING AS NECESSARY.
3. LIFT SPAN B TO REQUIRED ELEVATION AND INSTALL BEARING PEDESTALS AND NEW BEARINGS. PRIOR TO INSTALLING BEARING PEDESTALS AND NEW BEARINGS, CONTRACTOR SHALL MAKE ANY REPAIRS TO BENTS AS REQUIRED IN THE CONTRACT DOCUMENTS.
4. CONSTRUCT END BENT AND BENT MODIFICATIONS AS SHOWN IN THE CONTRACT DOCUMENTS. END BENT MODIFICATIONS NECESSARY TO ANCHOR THE SPAN SHALL BE COMPLETED PRIOR TO PROCEEDING.
5. SHIFT LIFT SYSTEM TO SPAN A AND REPEAT STEPS 2 THROUGH 4.
6. SHIFT LIFT SYSTEM TO SPAN C AND REPEAT STEPS 2 THROUGH 4.
7. SHIFT LIFT SYSTEM TO SPAN D AND REPEAT STEPS 2 THROUGH 4.
8. SHIFT LIFT SYSTEM TO SPAN E AND REPEAT STEPS 1 THROUGH 4.
9. PREPARE DECK AND PLACE LATEX MODIFIED CONCRETE OVERLAY.
10. FINISH REMAINING REPAIRS AND MODIFICATIONS AS INDICATED IN CONTRACT DOCUMENTS. REMOVE TRAFFIC CONTROL MEASURES AND OPEN BRIDGE TO TRAFFIC.

REVISION #1: REVISED PER REVIEW COMMENTS
 BY: TJT DATE: 5-08
 CH'KD BY: KGB DATE: 5-08

DRAWN BY: TJT DATE: 3-08
 CHECKED BY: MFR DATE: 3-08

D-1809.12

STV / Ralph Whitehead Associates, Inc.
 1000 West Morehead St., Ste. 200
 Charlotte, NC 28208

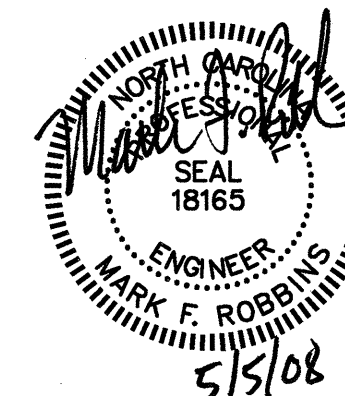
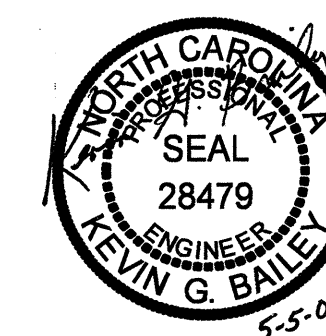

PROJECT NO. B-5021
 ROBESON COUNTY
 BRIDGE: 54

STATE OF NORTH CAROLINA
 DEPARTMENT OF TRANSPORTATION
 RALEIGH

BRIDGE JACKING SEQUENCE

REVISIONS						SHEET NO.
NO.	BY:	DATE:	NO.	BY:	DATE:	5-12
1	STV	5-08	3			TOTAL SHEETS
2			4			62

N:\PROJ\2513448\B5021\Roadway\Proj\Bridg\54\Structures\Istation\Finals\Substructure Interior Bent.dgn
 6:38:33 AM
 5/2/2008
 timothy.townsend

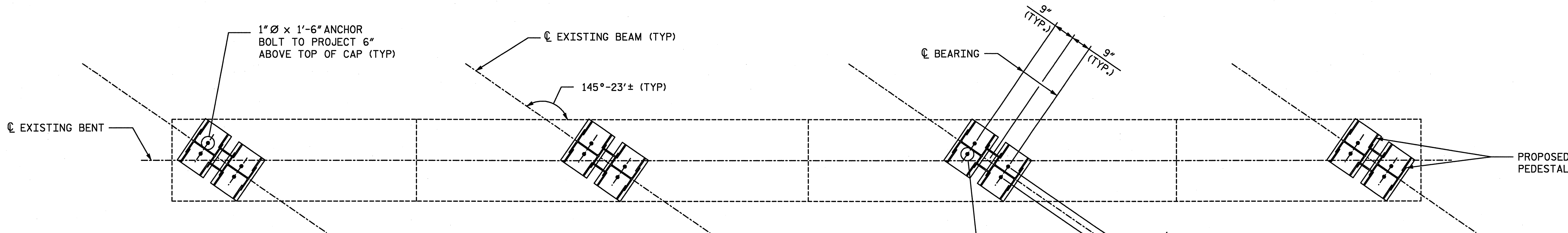

LOCATE ANCHOR BOLTS IN THE SAME LOCATION AS THE EXISTING ANCHOR BOLTS (TYP.)

NOTES

- △ THE EXISTING ANCHOR BOLTS SHALL BE CUT FLUSH WITH THE EXISTING TOP OF CAP. ANCHOR BOLTS SHALL BE DRILLED AND ADHESIVELY ANCHORED INTO THE EXISTING CAP. CONTRACTOR SHALL CORE DRILL THE EXISTING ANCHOR BOLTS USING A CORE BIT WITH INSIDE DIAMETER MATCHING THAT OF THE EXISTING ANCHOR BOLT DIAMETER. THE ANCHOR BOLT HOLES IN THE PROPOSED TOP AND BOTTOM PLATE DETAIL SHALL MATCH THE ANCHOR BOLT HOLES IN THE EXISTING BEAMS. THIS MATCH SHALL FACILITATE THE PROPER ALIGNMENT OF THE PEDESTAL. THE ANCHOR BOLT LENGTH IS BASED ON AN 12" EMBEDMENT INTO THE EXISTING CAP AND MAY BE ADJUSTED BASED ON THE MINIMUM EMBEDMENT SPECIFIED BY THE MANUFACTURER OF THE EPOXY ADHESIVE BONDING SYSTEM. FOR ADHESIVELY ANCHORED ANCHOR BOLTS, SEE SPECIAL PROVISIONS.
- △ THE CONTRACTOR SHALL FIELD VERIFY PROPOSED ANCHOR BOLT LOCATIONS PRIOR TO FABRICATION OF THE TOP AND BOTTOM PLATES FOR THE PROPOSED PEDESTALS.
- △ FOR CLEANING AND PAINTING EXISTING BEARING PLATES, SEE SPECIAL PROVISION.
- * THE PROPOSED PEDESTAL HEIGHT ASSUMES THAT THE TOTAL HEIGHT OF THE EXISTING BEARING ASSEMBLIES IS 2 1/2". THE CONTRACTOR SHALL MEASURE THE HEIGHT OF ALL BEARING ASSEMBLIES AND ADJUST THE HEIGHT OF THE PROPOSED PEDESTALS ACCORDINGLY.
- △ ALL THREADS OF BOLTS/ANCHOR BOLTS SHALL BE BURRED AFTER TIGHTENING NUTS.
- △ CONTRACTOR SHALL CLIP PLATES AS NECESSARY TO PREVENT PROJECTION BEYOND BENT CAP.
- △ 1" Ø BOLTS IN TOP PLATE SHALL CONFORM TO ASTM A325.
- △ 1" Ø ANCHOR BOLTS SHALL BE IN ACCORDANCE WITH THE STANDARD SPECIFICATIONS. CONTRACTOR SHALL VERIFY ANCHOR BOLT DIAMETER AND ADJUST AS NECESSARY TO MATCH EXISTING ANCHOR BOLT DIAMETER.
- △ PROPOSED PEDESTALS SHALL BE GALVANIZED IN ACCORDANCE WITH SECTION 1076 OF THE STANDARD SPECIFICATIONS. AREAS TO BE WELDED SHALL BE REPAIRED IN ACCORDANCE WITH THE STANDARD SPECIFICATIONS.

PLAN OF EXISTING BENT

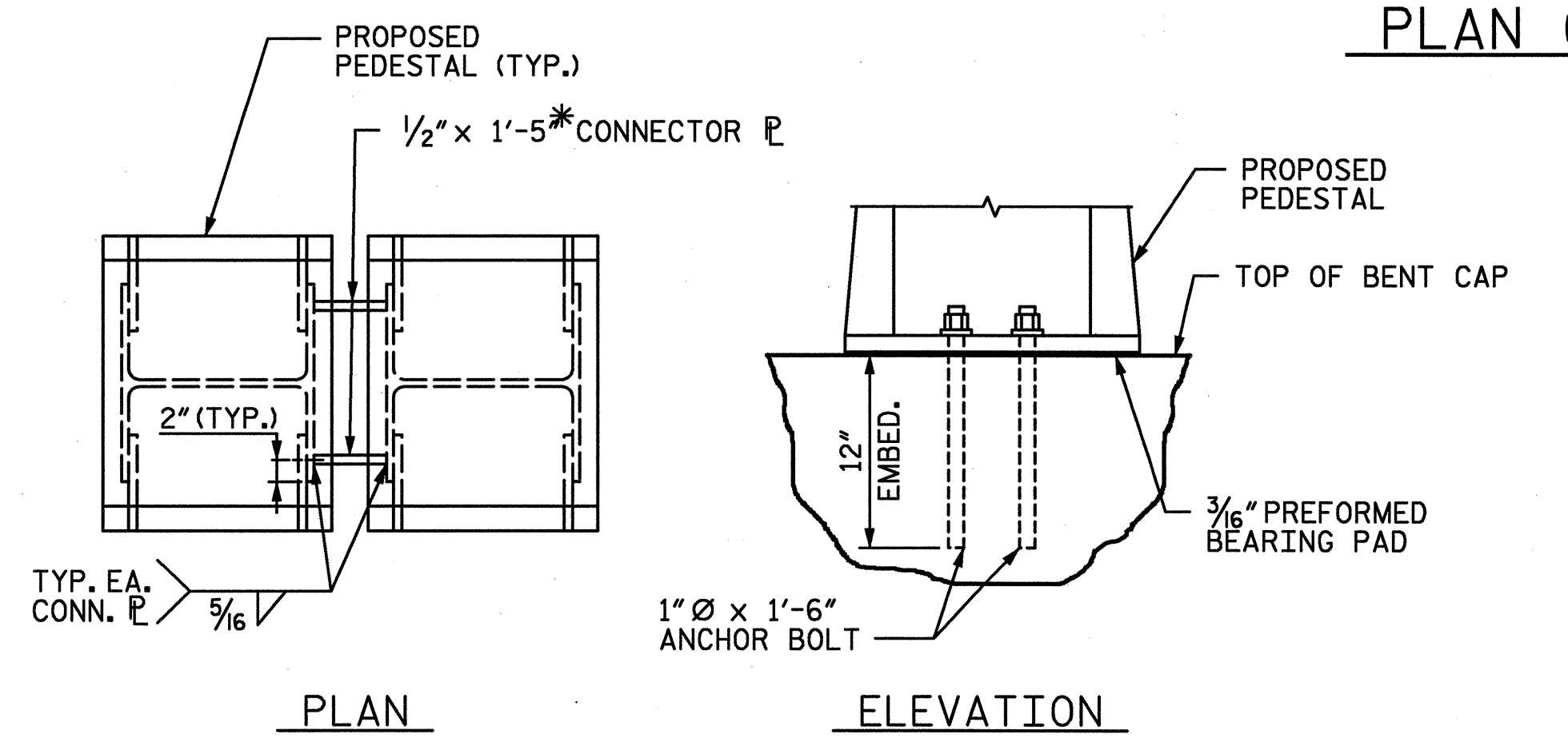

PEDESTAL ATTACHMENT DETAIL
(CONNECTOR PLATES SHALL BE INSTALLED AFTER BEARING ASSEMBLIES HAVE BEEN INSTALLED)

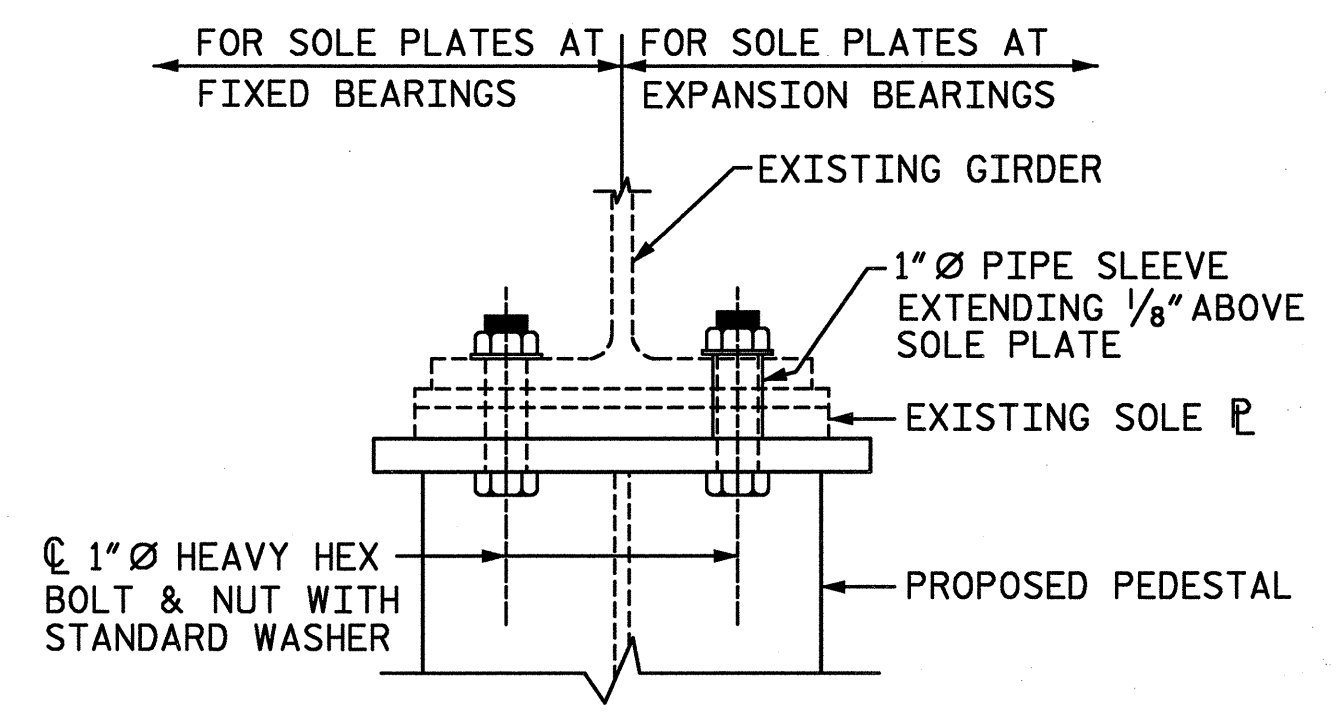

BEARING ATTACHMENT DETAIL
(CONTRACTOR SHALL VERIFY BOLT DIMENSION AND ADJUST HOLE DIAMETER AS NECESSARY PRIOR TO PEDESTAL FABRICATION)

STRUCTURAL STEEL (APPROX. LBS.) 9940

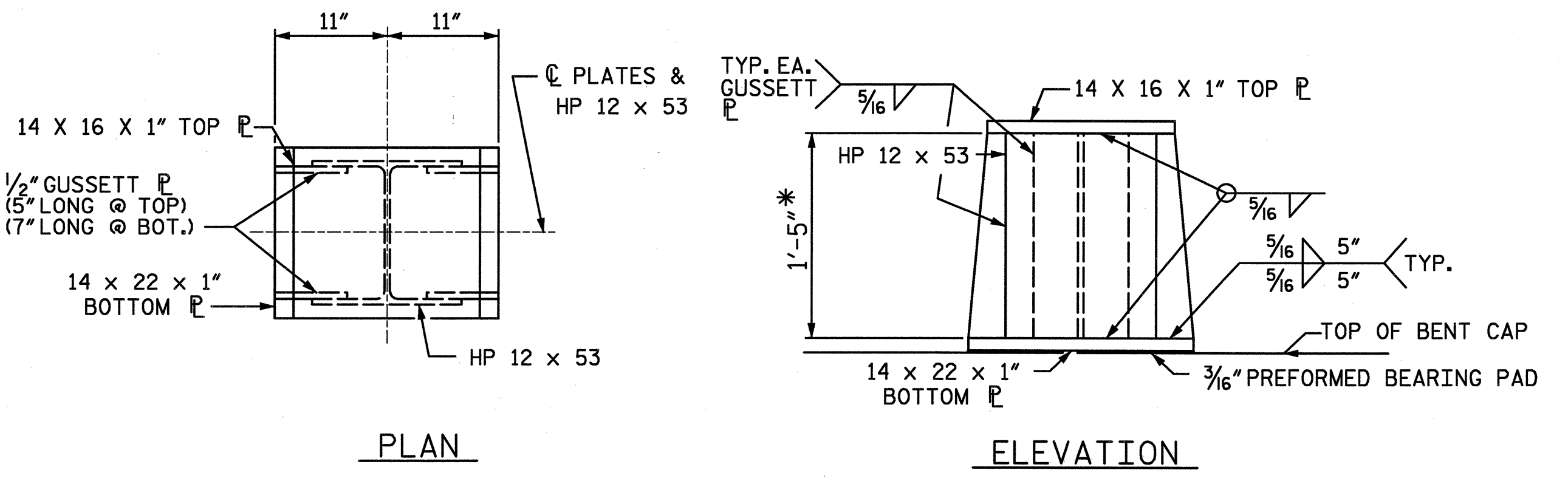

PEDESTAL DETAILS

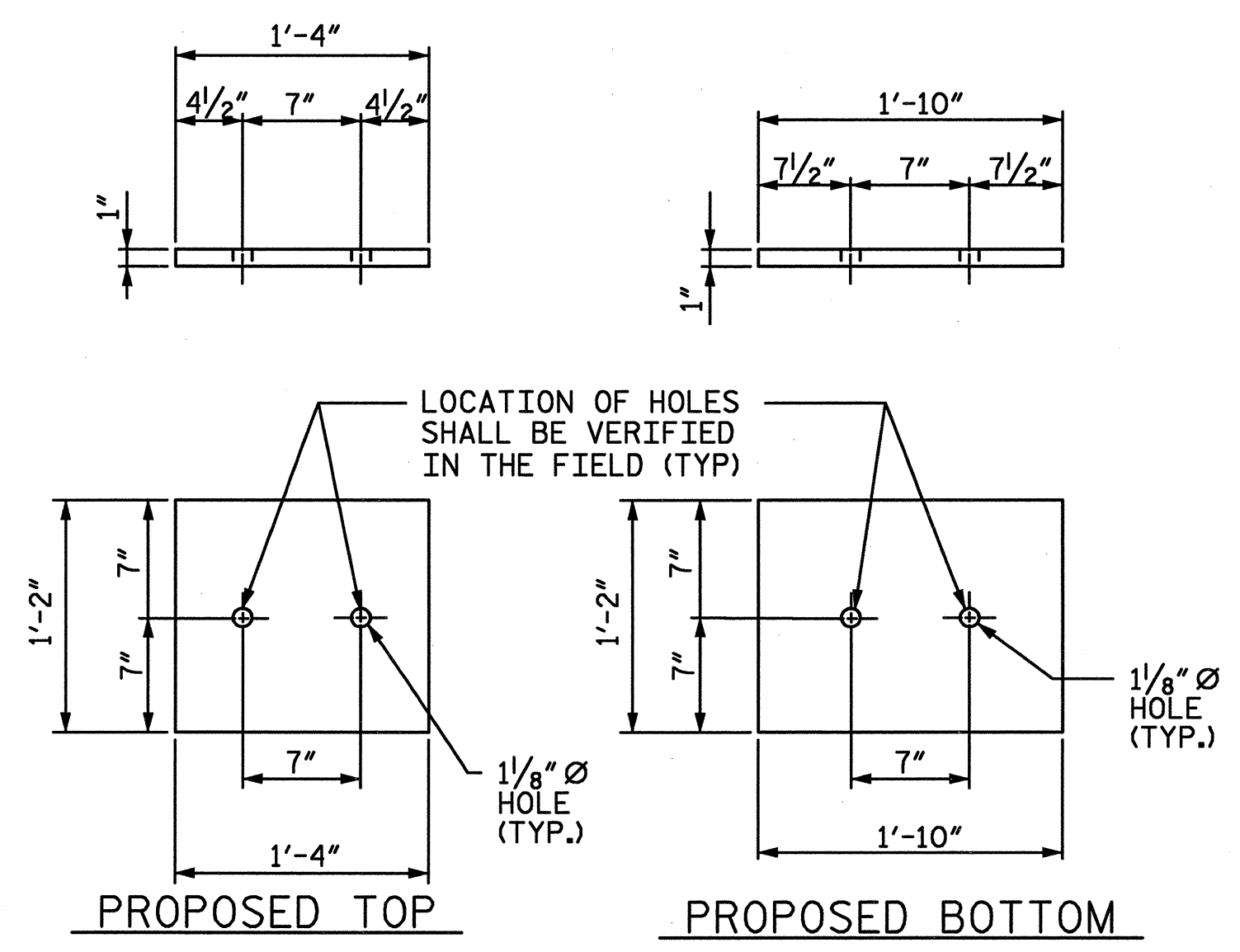
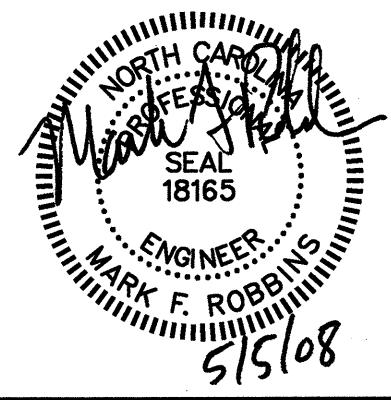
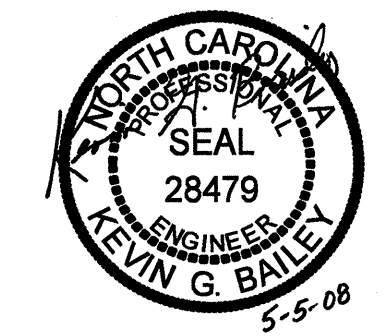

PLATE DETAIL

△ REVISION #1: REVISED PER REVIEW COMMENTS
 BY: TJT DATE: 5-08
 CH'KD BY: KGB DATE: 5-08

NOT TO SCALE



PROJECT NO. B-5021
 ROBESON COUNTY
 BRIDGE: 54

STATE OF NORTH CAROLINA
 DEPARTMENT OF TRANSPORTATION
 RALEIGH
 SUBSTRUCTURE
 INTERIOR BENT
 BEARING MODIFICATIONS

DRAWN BY: TJT DATE: 1-08
 CHECKED BY: KGB DATE: 3-08

D-1809.13
 STV/Ralph Whitehead Associates, Inc.
 1000 West Morehead St., Ste. 200
 Charlotte, NC 28208

REVISIONS						SHEET NO.
NO.	BY:	DATE:	NO.	BY:	DATE:	TOTAL SHEETS
1	STV	5-08	3			5-13
2			4			62

N:\PROJ\2513448\B5021\Bridg 54\Station\Final\Substructure Repairs.dgn
 4/10/2008 11:04:15 AM
 timothy.townsend

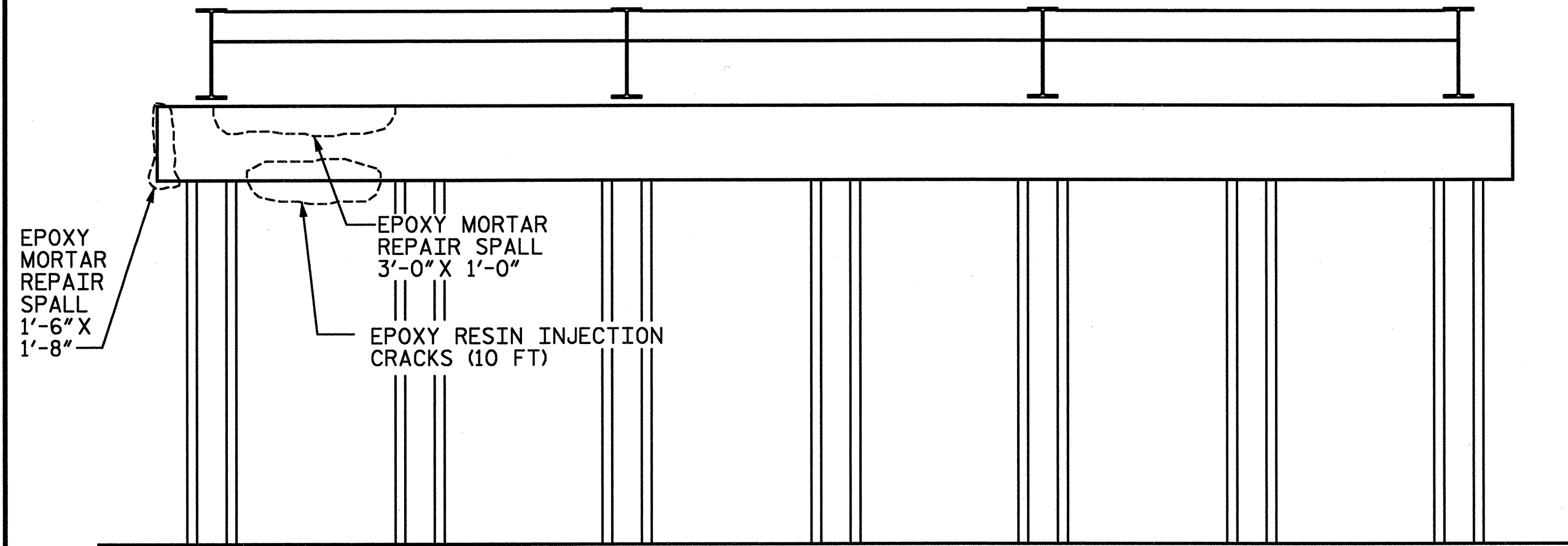

BENT 1 ELEVATION
(LOOKING SOUTH)
(@ NORTH FACE)

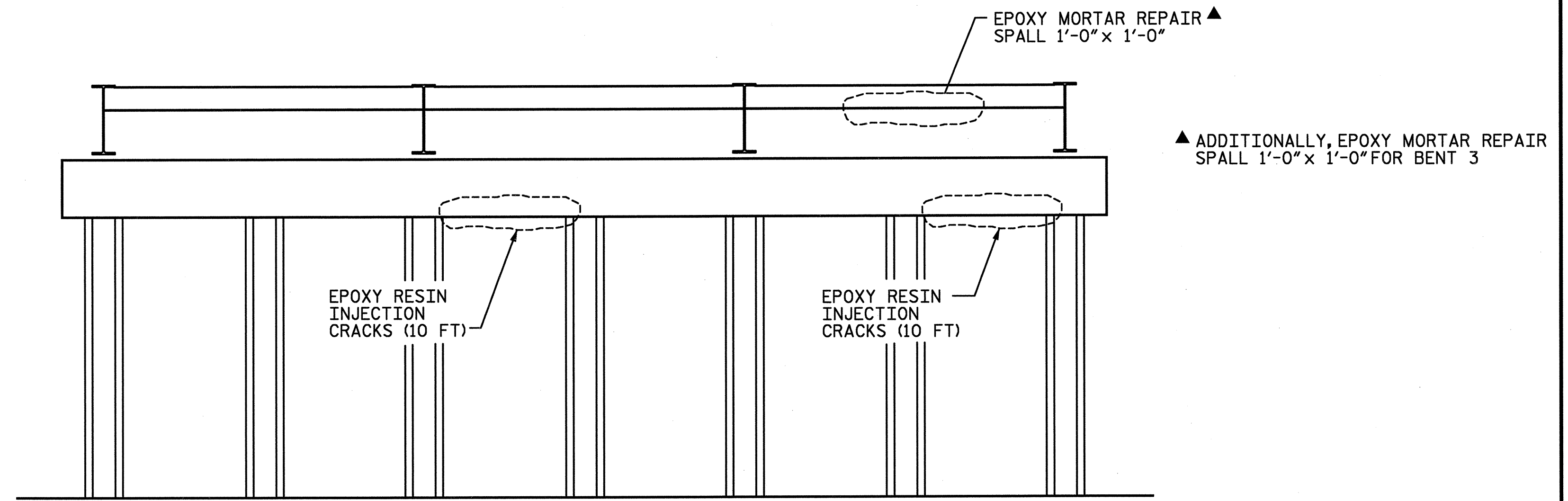

BENT 4 ELEVATION
(LOOKING NORTH)
(@ SOUTH FACE)

NOTES:

1. REPAIRS SHALL BE IMPLEMENTED WHEN BRIDGE IS RAISED ABOVE REPAIR.
2. BLOCKING SHALL NOT BE POSITIONED OVER REPAIR UNTIL REPAIR HAS CURED.
3. SAWCUT 1/4" - 1/2" DEEP AROUND ALL SPALLS.
4. FOR EPOXY RESIN INJECTION, SEE SPECIAL PROVISIONS.
5. FOR EPOXY MORTAR REPAIR, SEE SPECIAL PROVISIONS.

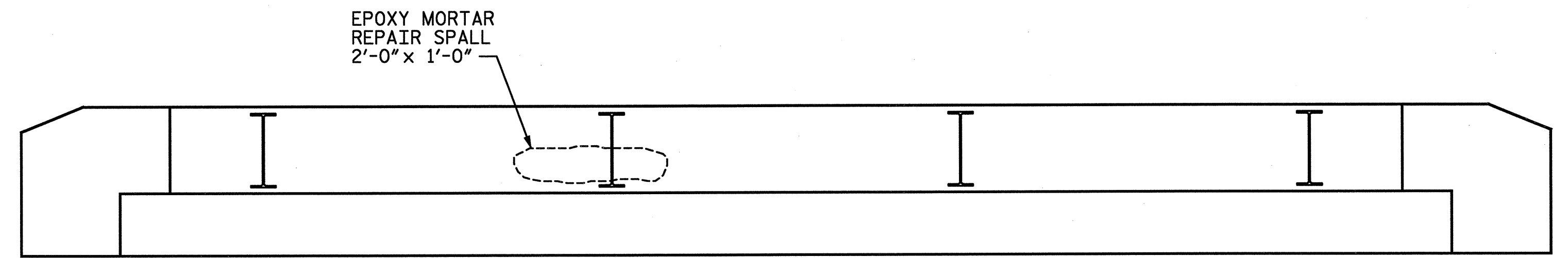

END BENT 1 ELEVATION
(FACING END BENT)

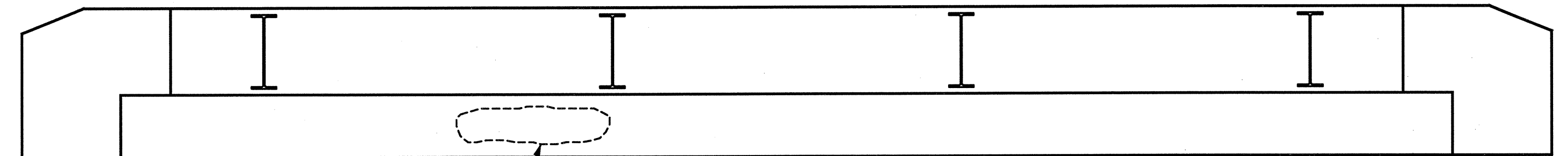

END BENT 2 ELEVATION
(FACING END BENT)

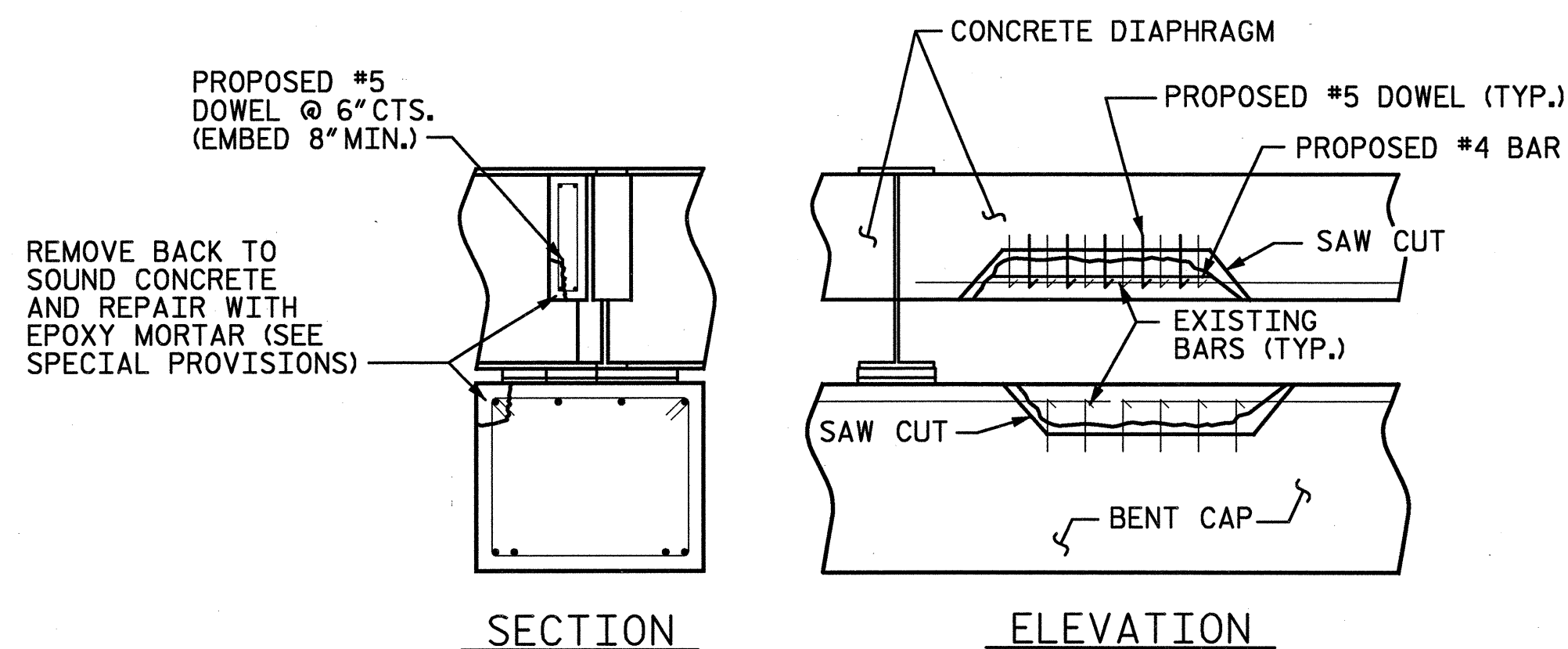

TYPICAL BENT AND DIAPHRAGM REPAIR DETAIL

PROJECT NO. B-5021
 ROBESON COUNTY
 BRIDGE: 54

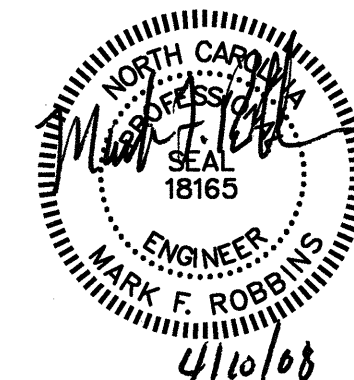
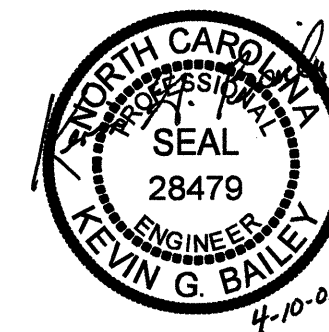

STATE OF NORTH CAROLINA DEPARTMENT OF TRANSPORTATION RALEIGH					
SUBSTRUCTURE REPAIRS					
REVISIONS					
NO.	BY:	DATE:	NO.	BY:	DATE:
1			3		
2			4		
SHEET NO.					S-14
TOTAL SHEETS					62

D-1809.14
 STV / Ralph Whitehead Associates, Inc.
 1000 West Morehead St., Ste. 200
 Charlotte, NC 28208

NOTES

DIMENSIONS ARE BASED ON BEST AVAILABLE INFORMATION. CONTRACTOR SHALL FIELD VERIFY DIMENSIONS PRIOR TO CONSTRUCTION.

PORTIONS OF EXISTING END BENT SHOWN IN CROSS-HATCHED AREAS SHALL BE REMOVED.

VERTICAL AND HORIZONTAL REINFORCING STEEL EXTENDING FROM THE END BENT CAP INTO THE EXISTING WINGWALLS SHALL BE CLEANED AND STRAIGHTENED. CUT EXISTING REINFORCING STEEL TO MAINTAIN REQUIRED CONCRETE COVER. MINIMUM 14" EXTENSION INTO THE PROPOSED WINGWALL.

BARS DAMAGED DURING THE CONCRETE REMOVAL SHALL BE REPLACED BY #6 DOWELS SECURED IN THE EXISTING END BENT CAP WITH EPOXY ADHESIVE AT NO ADDITIONAL PAYMENT.

THE #6 DOWEL LENGTH SHALL BE BASED ON A 9" EMBEDMENT INTO EXISTING CONCRETE AND MAY BE ADJUSTED BASED ON THE MINIMUM EMBEDMENT SPECIFIED BY THE MANUFACTURER OF THE EPOXY ADHESIVE BONDING SYSTEM. SEE SPECIAL PROVISION FOR ADHESIVELY ANCHORED ANCHOR BOLTS OR DOWELS.

EXISTING ANCHOR BOLTS ARE TO BE CUT FLUSH WITH THE EXISTING TOP OF CAP.

THE EXISTING CURTAIN WALL CONCRETE AROUND ANCHOR BOLTS AND BEARING ASSEMBLIES SHALL BE REMOVED, USING HAND TOOLS, AS NECESSARY TO FREE ANCHOR BOLTS AND BEARING ASSEMBLIES. THE CONTRACTOR SHALL EXERCISE CARE DURING THE REMOVAL OF EXISTING CONCRETE TO INSURE THAT EXISTING GIRDERS, BEARING ASSEMBLIES AND CURTAIN WALL STEEL REMAIN UNDAMAGED.

CONTRACTOR SHALL REMOVE EXISTING APPROACH SLAB BRACKET AS NECESSARY TO ACCOMMODATE PROPOSED APPROACH SLAB BRACKET. EXISTING APPROACH SLAB BRACKET NOT SHOWN FOR CLARITY.

ALL WORK ON THIS SHEET WILL BE PAID FOR UNDER THE LUMP SUM BID PRICE FOR PARTIAL REMOVAL OF EXISTING STRUCTURE.

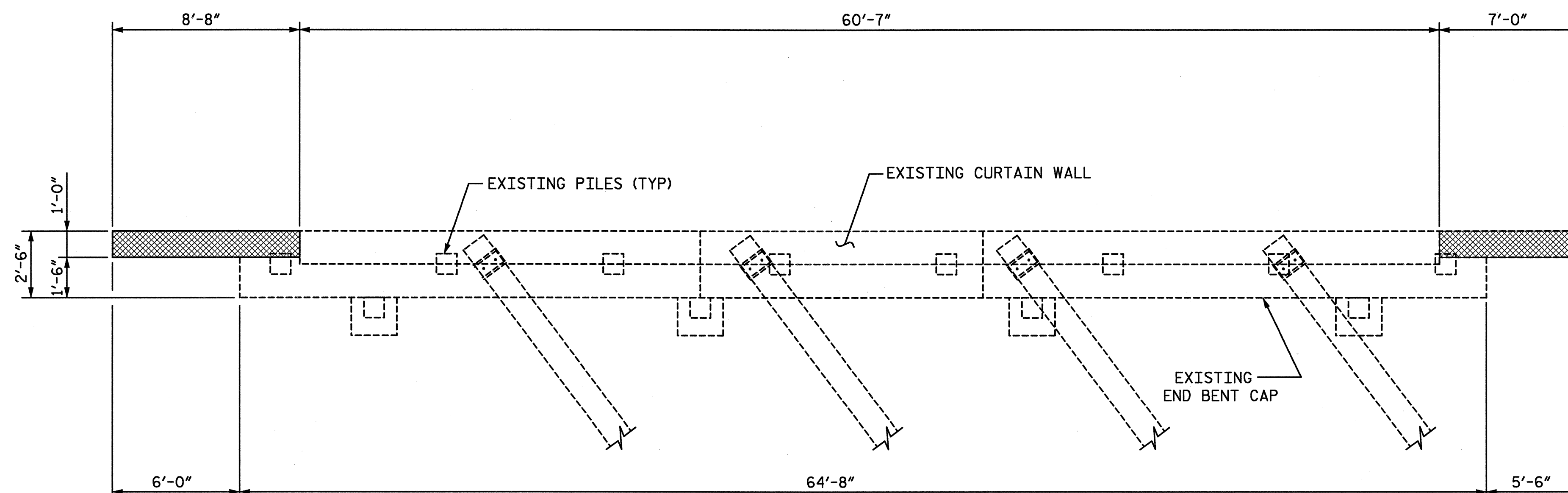

PLAN OF EXISTING CAP
END BENT 2 SHOWN, END BENT 1 SIMILAR

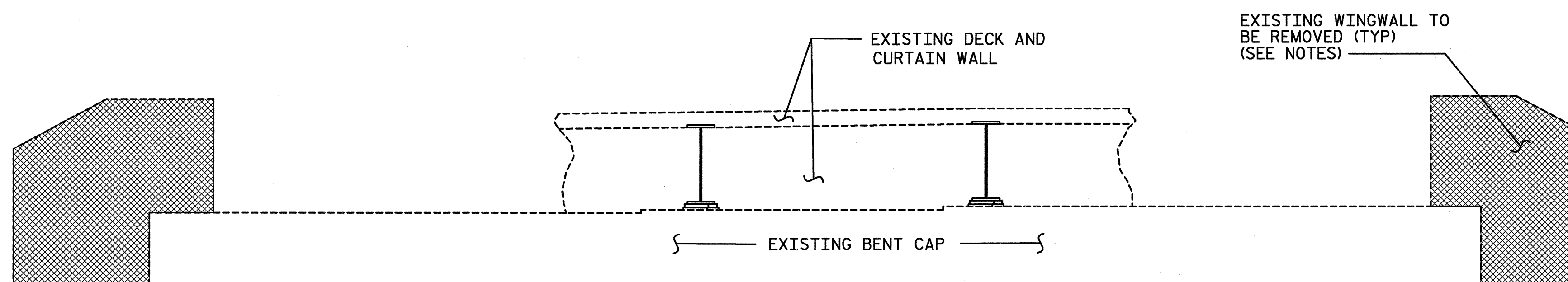

ELEVATION OF EXISTING CAP
END BENT 2 SHOWN, END BENT 1 SIMILAR

PROJECT NO. B-5021
ROBESON _____ COUNTY
BRIDGE: 54

SHEET 1 OF 4

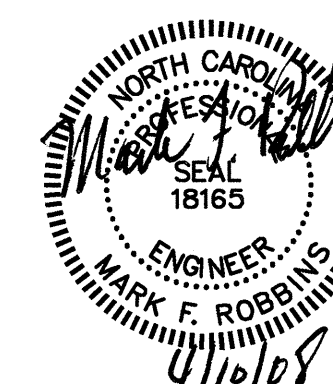
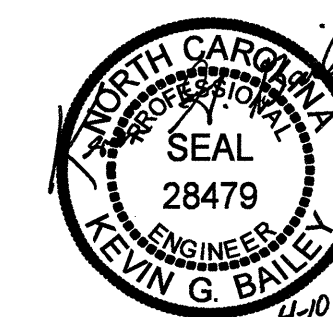

STATE OF NORTH CAROLINA
DEPARTMENT OF TRANSPORTATION
RALEIGH

SUBSTRUCTURE
END BENT
CONCRETE REMOVAL

REVISIONS						SHEET NO.
NO.	BY:	DATE:	NO.	BY:	DATE:	TOTAL SHEETS
1			3			5-15
2			4			62

D-1809.15

NOT TO SCALE

STV/Ralph Whitehead Associates, Inc.
1000 West Morehead St., Ste. 200
Charlotte, NC 28208

DRAWN BY: TJT DATE: 1-08
CHECKED BY: KGB DATE: 3-08

timothy.townsend 4/10/2008 11:04:13 AM N:\PROJ\2513448\B5021\Bridges 54\Ustration\Finalis\Substructure End Bent.dgn

NOTES

THE CONTRACTOR SHALL PROVIDE FOR INSTALLATION OF THE 4" DRAIN PIPE THROUGH THE WING WALL AS REQUIRED FOR REINFORCED BRIDGE APPROACH FILL. SEE BRIDGE APPROACH SLAB FOR FLEXIBLE PAVEMENT SHEET. REINFORCING STEEL IN THE WING WALL MAY BE SHIFTED SLIGHTLY AS NECESSARY TO CLEAR DRAIN PIPE.

BILL OF MATERIAL
FOR ONE END BENT
(2 REQ'D)

BAR	NO.	SIZE	TYPE	LENGTH	WEIGHT
B1	16	#4	1	4'-3"	45
D1	61	#6	STR	1'-6"	137
D2	6	#6	7	4'-3"	39
H1	10	#4	2	10'-0"	67
H2	10	#4	2	10'-11"	73
H3	7	#4	3	12'-4"	58
H4	10	#4	3	11'-5"	76
H5	3	#4	STR	11'-3"	23
J1	53	#5	6	2'-6"	138
J2	53	#5	7	1'-10"	101
K1	8	#8	STR	37'-0"	790
K2	16	#4	1	4'-1"	44
K3	8	#4	5	7'-7"	41
K4	10	#4	STR	3'-4"	22
K5	10	#4	STR	4'-5"	30
K6	2	#5	STR	52'-2"	109
S1	122	#4	4	3'-2"	258
V1	25	#4	STR	8'-2"	136
V2	16	#4	STR	6'-6"	70
V3	25	#4	STR	8'-0"	134
REINFORCING STEEL					LBS. 2,391

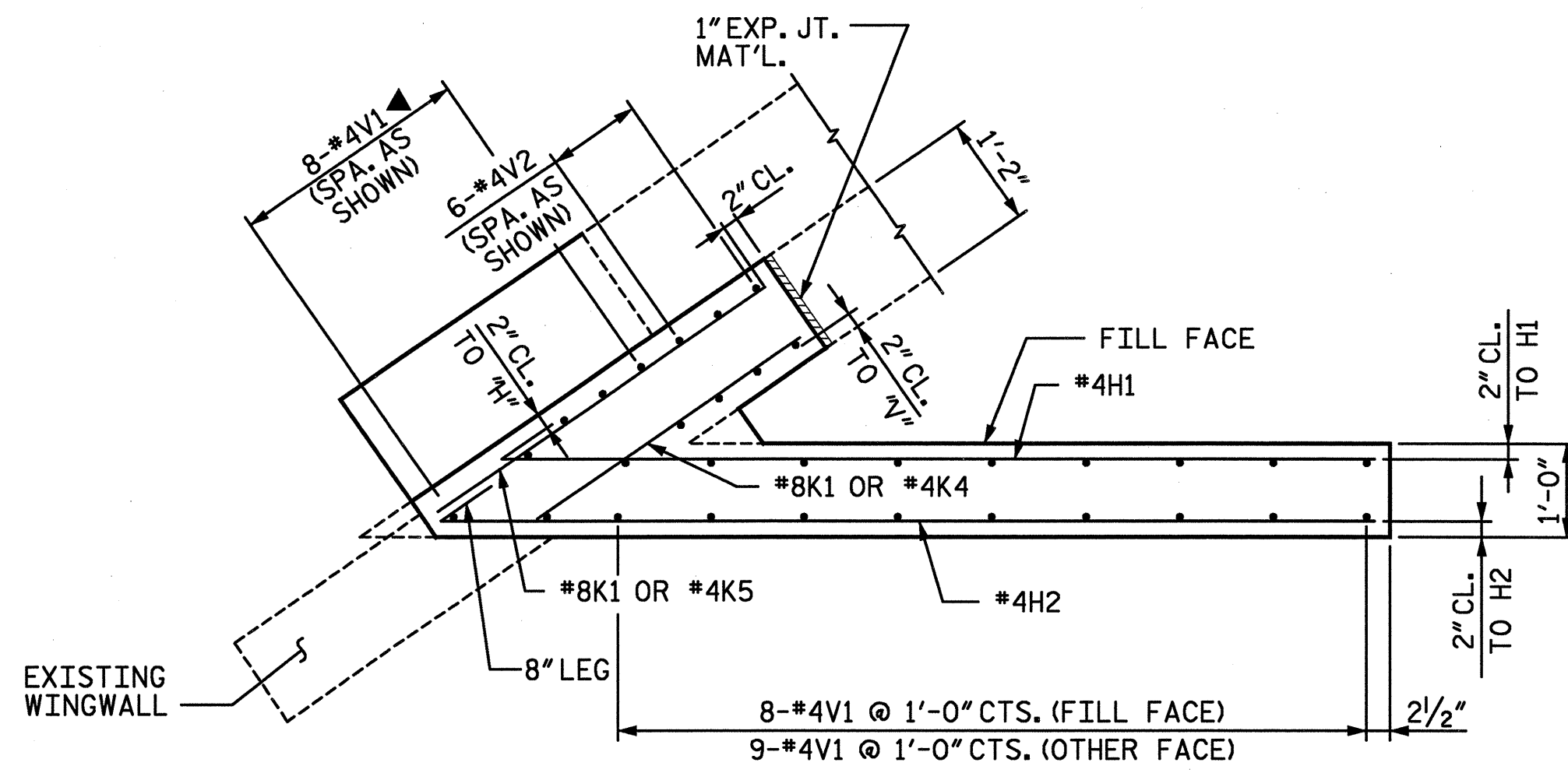

PLAN OF RIGHT WING - W1

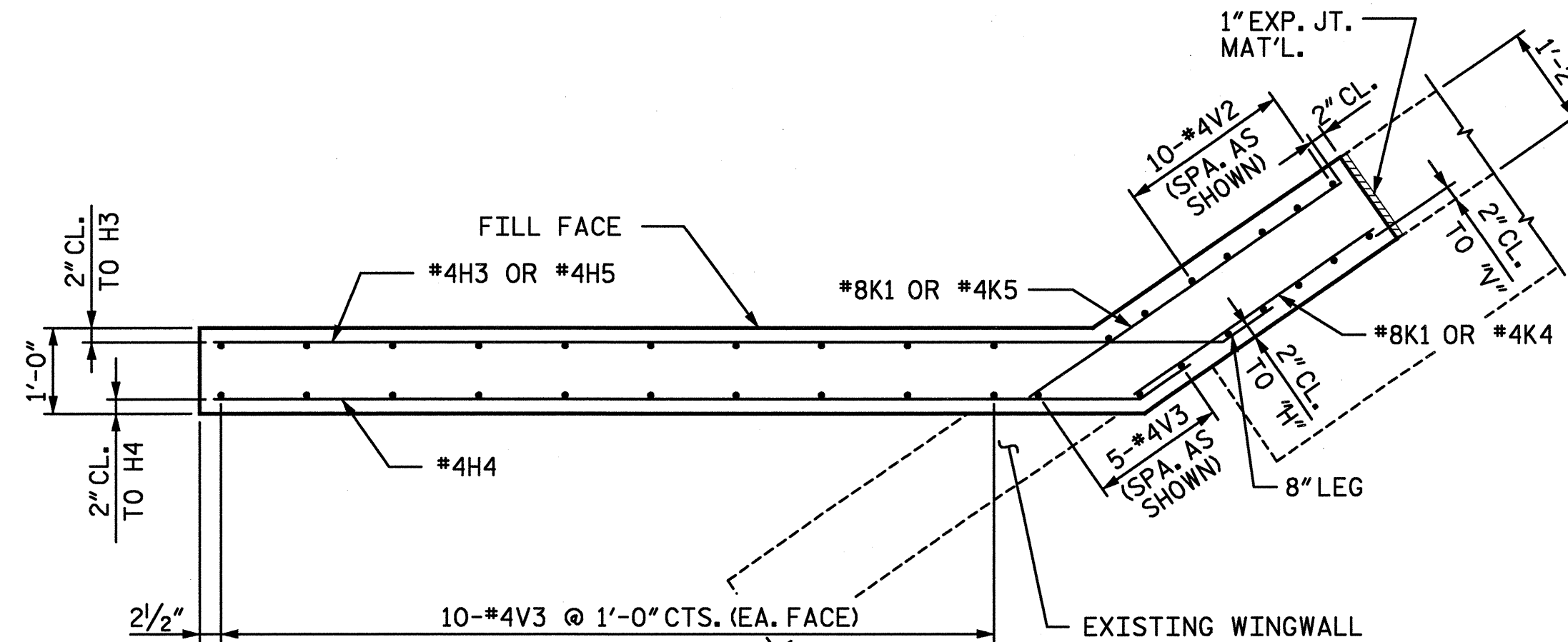

PLAN OF LEFT WING - W2

▲ #4V1 BARS SHALL BE CAST WITH PROPOSED END BENT CAP EXTENSION, POUR 1

NOTE: #4V2 BARS SHALL BE EPOXIED INTO EXISTING BENT CAP.

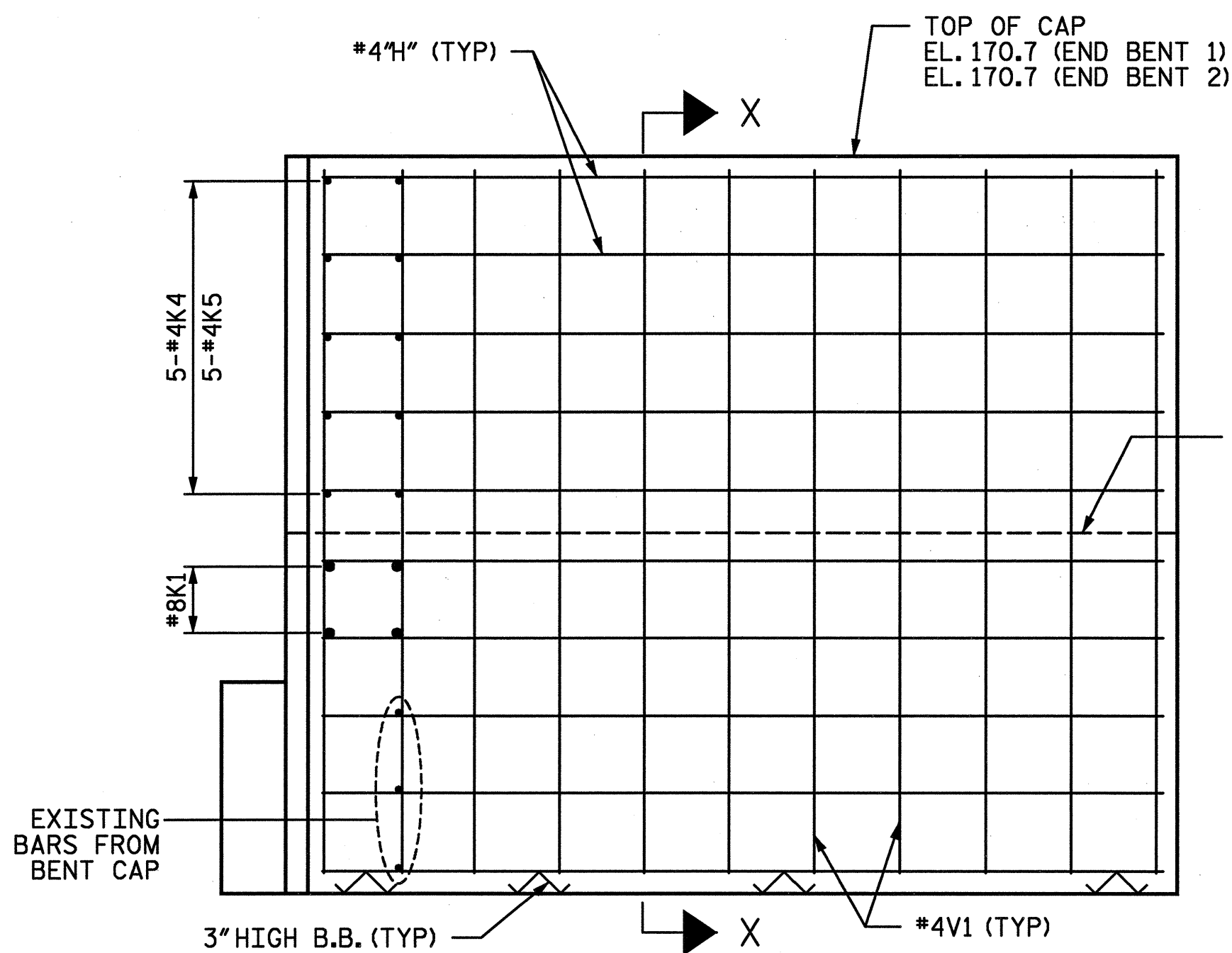

ELEVATION OF RIGHT WING

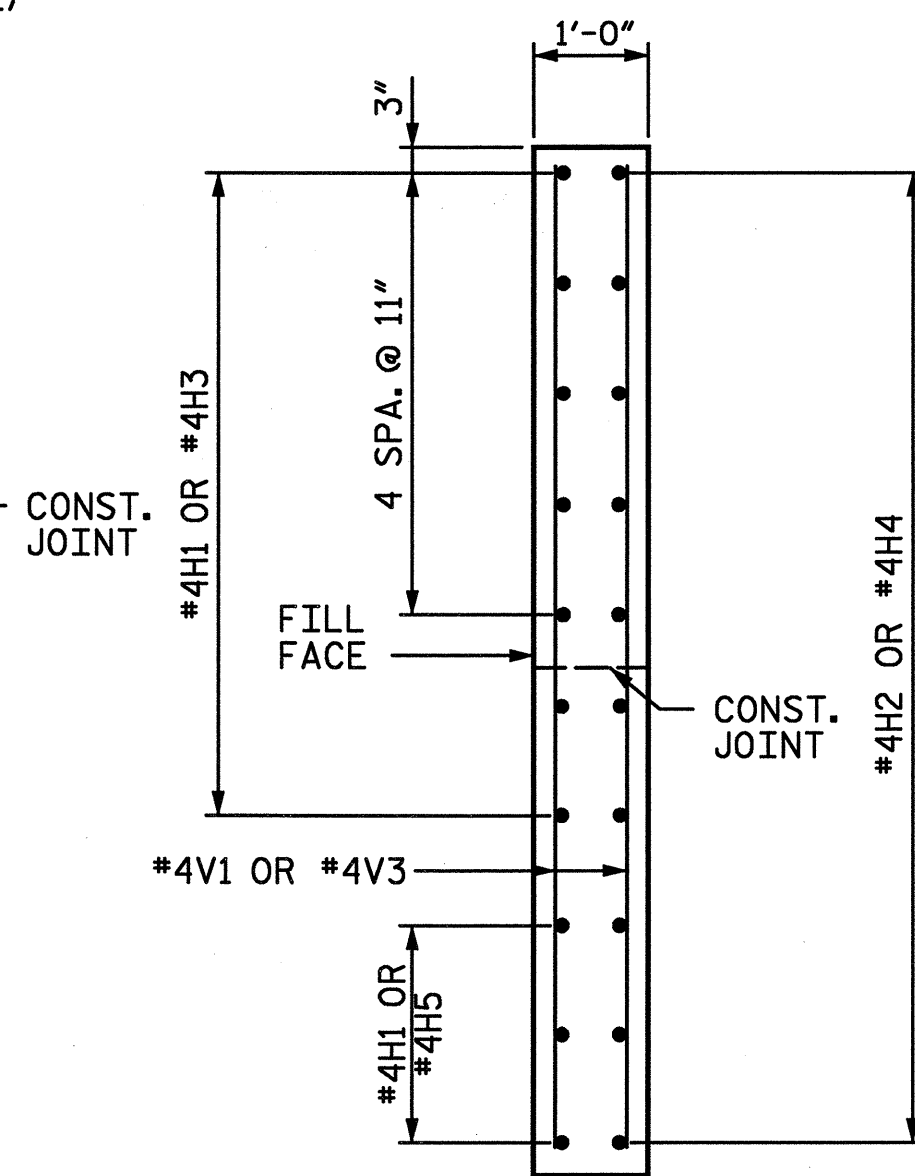

SECTION X-X

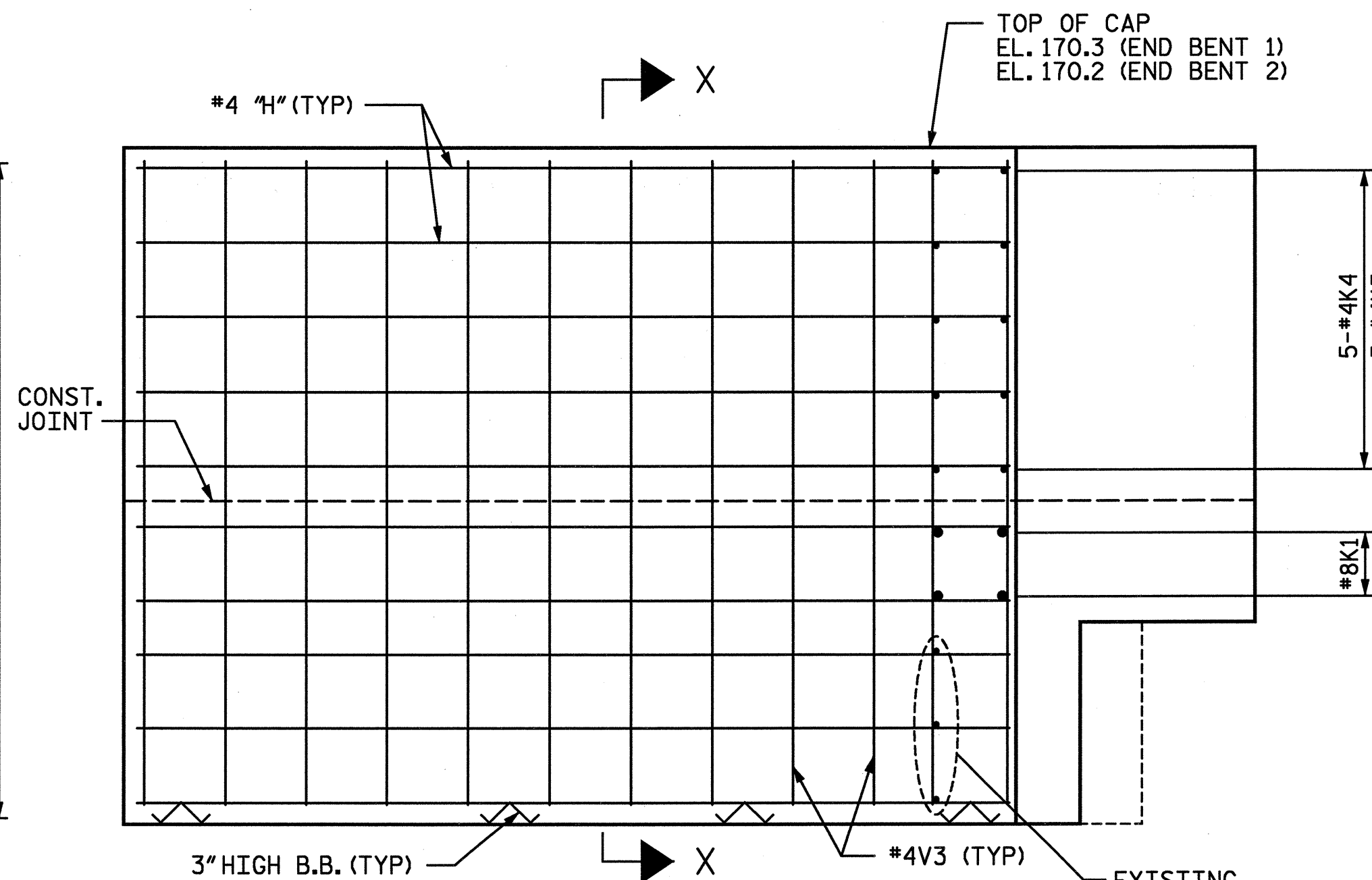

ELEVATION OF LEFT WING

REINFORCING FOR TURNED BACK WING
(END BENT 2 SHOWN, END BENT 1 SIMILAR)

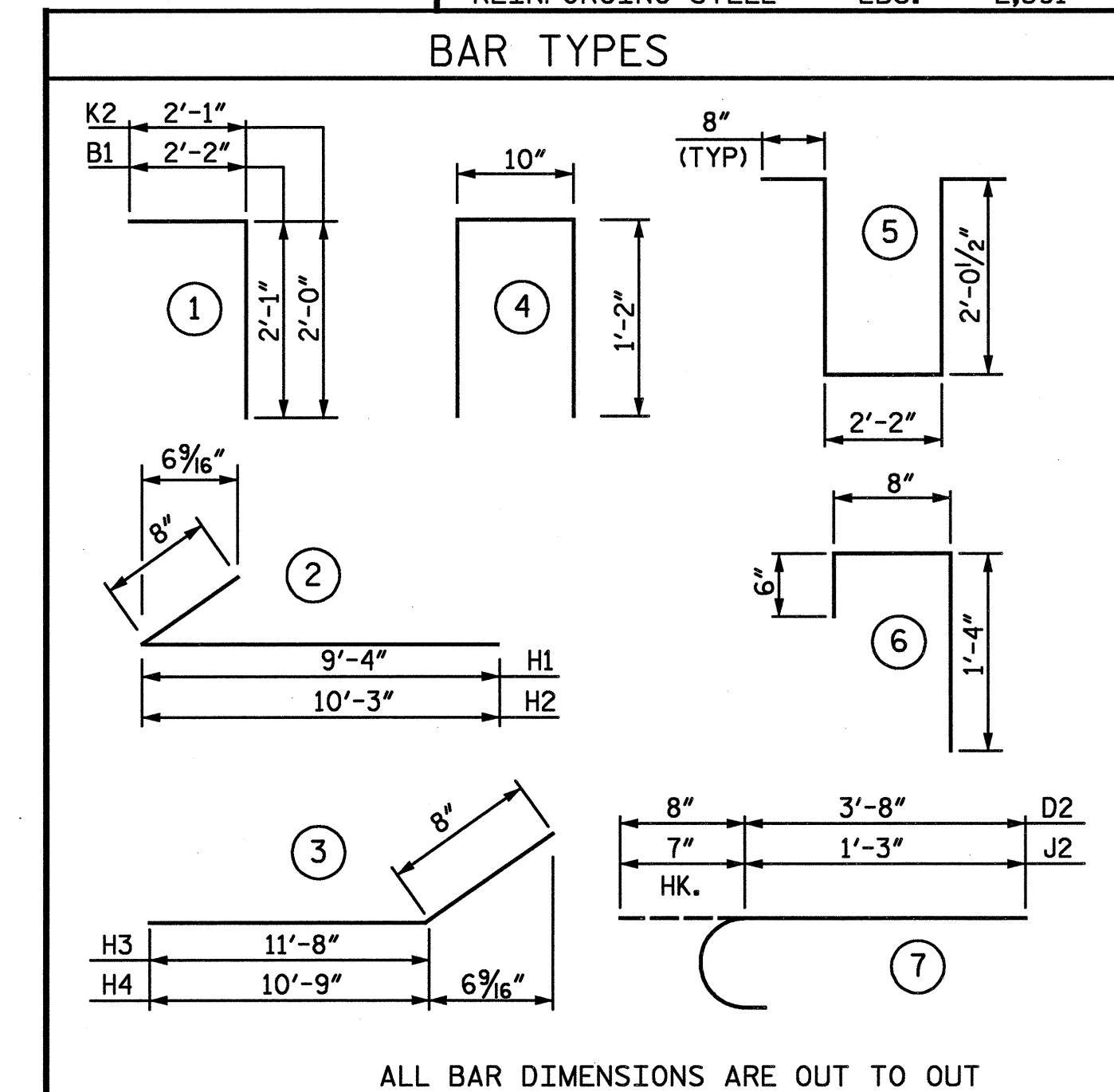

ALL BAR DIMENSIONS ARE OUT TO OUT

CLASS AA CONCRETE BREAKDOWN FOR ONE END BENT (2 REQ'D)

POUR 1	C. Y.	8.4
CAP AND LOWER WINGWALLS		
POUR 2	C. Y.	5.4
BRIDGE SEATS AND UPPER WINGWALLS		
POUR 3	C. Y.	1.5
APPROACH SLAB BRACKETS		
CLASS AA CONCRETE	C. Y.	15.3

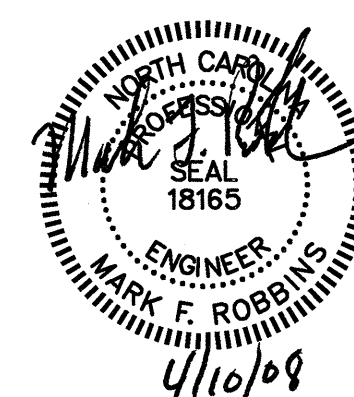

PROJECT NO. **B-5021**
ROBESON COUNTY
BRIDGE: **54**

SHEET 3 OF 4
STATE OF NORTH CAROLINA
DEPARTMENT OF TRANSPORTATION
RALEIGH
SUBSTRUCTURE
END BENT
WINGWALL MODIFICATIONS

REVISIONS						TOTAL SHEETS
NO.	BY:	DATE:	NO.	BY:	DATE:	62
1			3			
2			4			

NOT TO SCALE

D-1809.17
STV/ Ralph Whitehead Associates, Inc.
1000 West Morehead St., Ste. 200
Charlotte, NC 28208

N:\PROJ\2513448\B5021\Bridg 54\Illustration\Final\Substructure End Bent_3.dgn

11:04:10 AM

timothy.townsend 4/10/2008

DRAWN BY: TJT DATE: 1-08
CHECKED BY: KGB DATE: 3-08

N:\PROJ\2513448\B502\Brdge 54\Ustation\Final\Substructure End Bent_4.dgn
 4/10/2008 AM 11:04:08 AM timothy.townsend

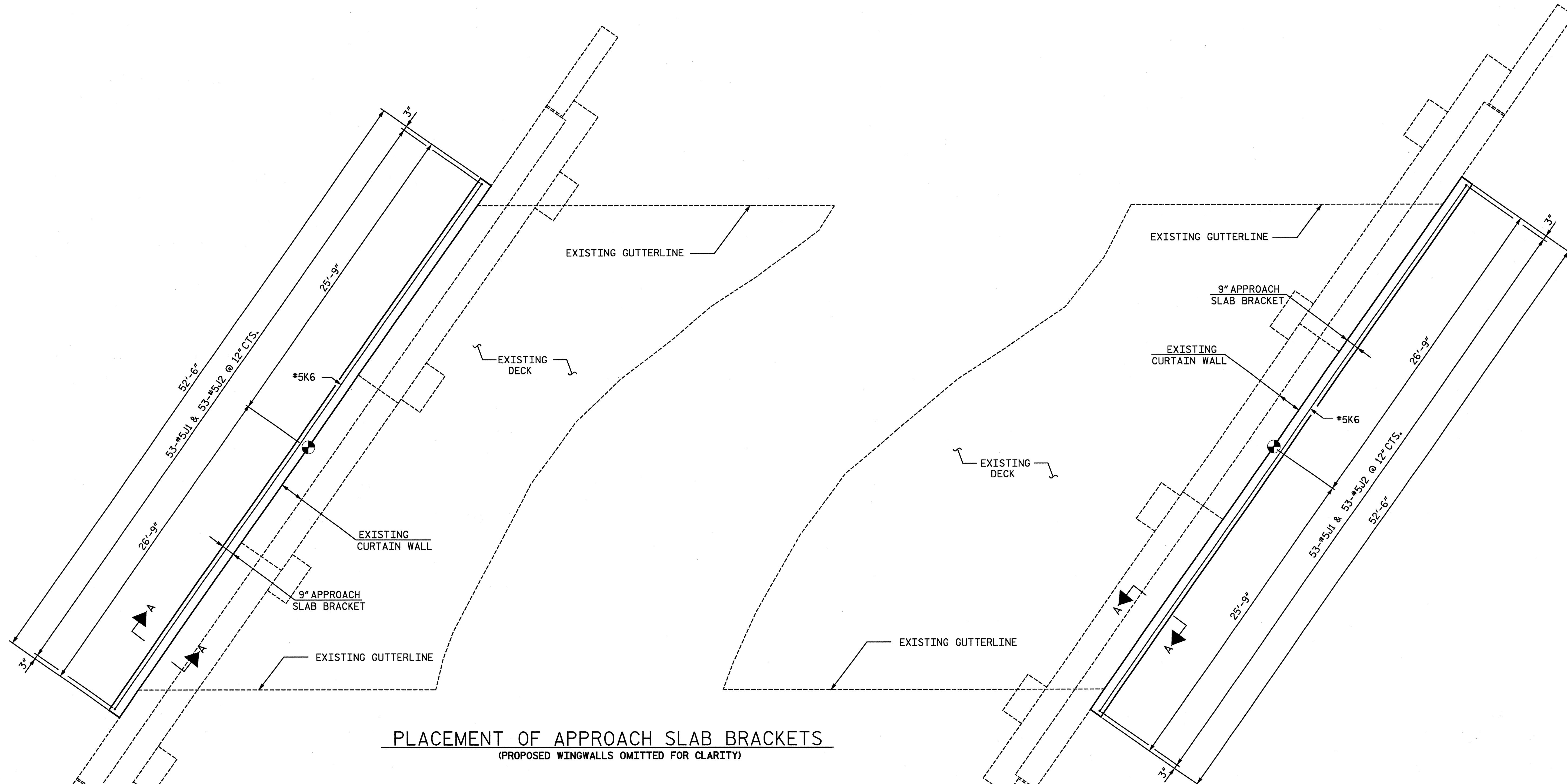

PLACEMENT OF APPROACH SLAB BRACKETS
 (PROPOSED WINGWALLS OMITTED FOR CLARITY)

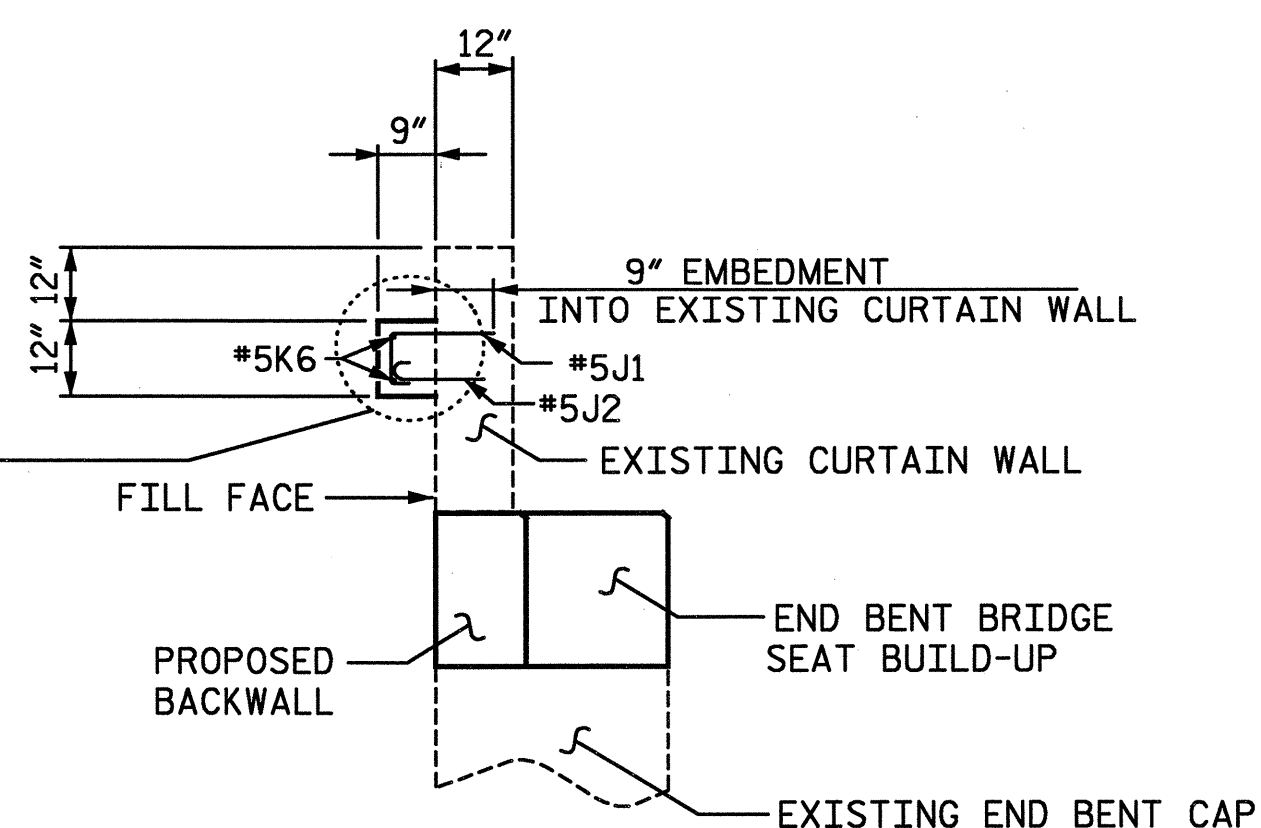
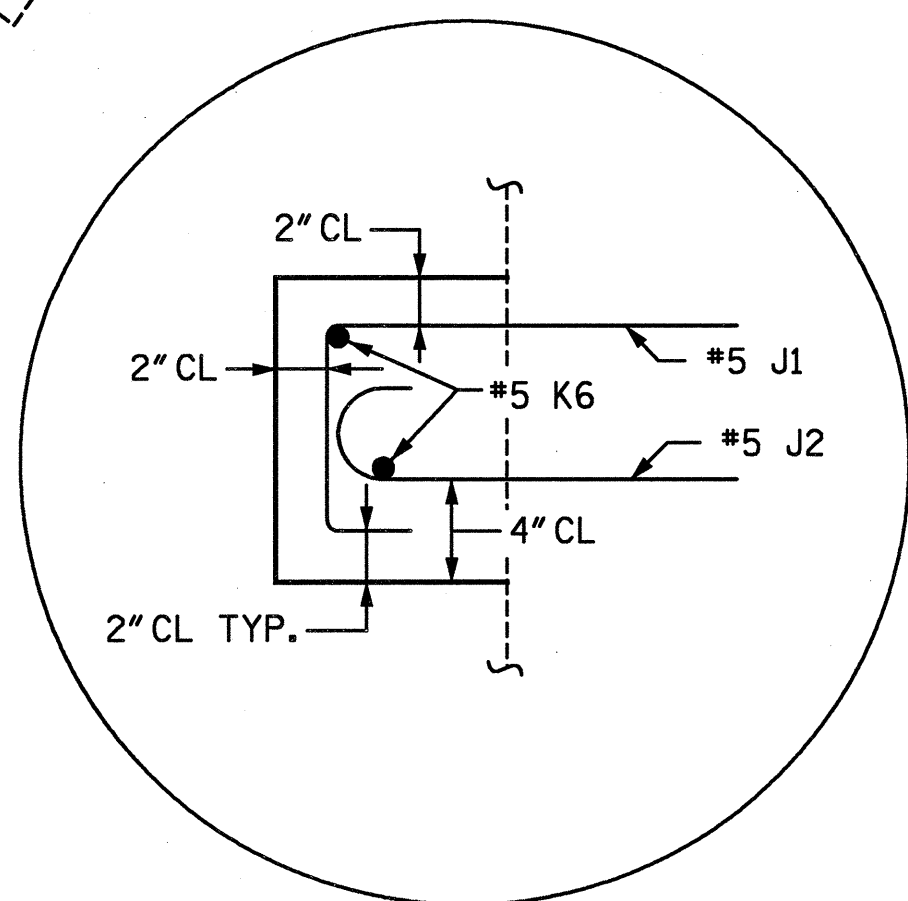

SECTION A-A

NOTES

- THE #5J1 AND #5J2 BARS SHALL BE SECURED INTO THE EXISTING CONCRETE WITH EPOXY ADHESIVE.
- THE LEG LENGTH OF THE #5J1 AND #5J2 BAR IS BASED ON A 9" EMBEDMENT INTO THE EXISTING CONCRETE AND MAY BE ADJUSTED BASED ON THE MINIMUM EMBEDMENT SPECIFIED BY THE MANUFACTURER OF THE EPOXY ADHESIVE BONDING SYSTEM.
- INSTALL #5J2 BARS AND THEN INSTALL #5J1 BARS TO ALLOW FOR BAR ROTATION DURING INSTALLATION.
- #5J1 AND #5J2 BARS SHALL BE EPOXIED INTO EXISTING CURTAIN WALL AS DETAILED. THE COST OF DRILLING IN AND EPOXYING THE #5J1 AND #5J2 BARS SHALL BE CONSIDERED INCIDENTAL AND INCLUDED IN THE COST OF THE REINFORCING STEEL.

FOR ADHESIVELY ANCHORED ANCHOR BOLTS OR DOWELS, SEE SPECIAL PROVISIONS. **NOT TO SCALE**

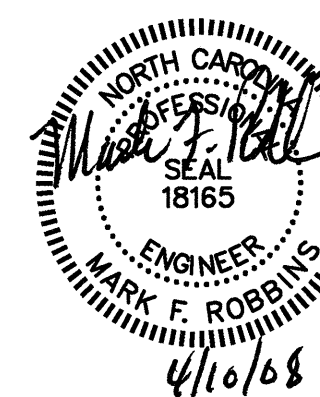
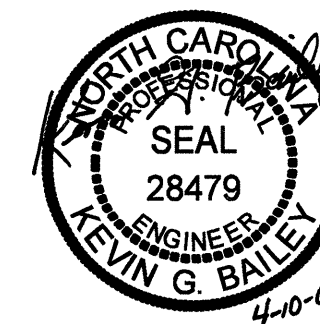

PROJECT NO. B-5021
 ROBESON COUNTY
 BRIDGE: 54
 SHEET 4 OF 4

STATE OF NORTH CAROLINA
 DEPARTMENT OF TRANSPORTATION
 RALEIGH
 SUBSTRUCTURE
 END BENT
 APPROACH SLAB BRACKETS

REVISIONS						SHEET NO.
NO.	BY:	DATE:	NO.	BY:	DATE:	TOTAL SHEETS
1			3			5-18
2			4			62

D-1809.18

 STV/Ralph Whitehead Associates, Inc.
 1000 West Morehead St., Ste. 200
 Charlotte, NC 28208

4/10/2008 11:04:07 AM N:\PROJ\2513448\B5021\Bridg 54\1station\Final\Approach Slab.dgn

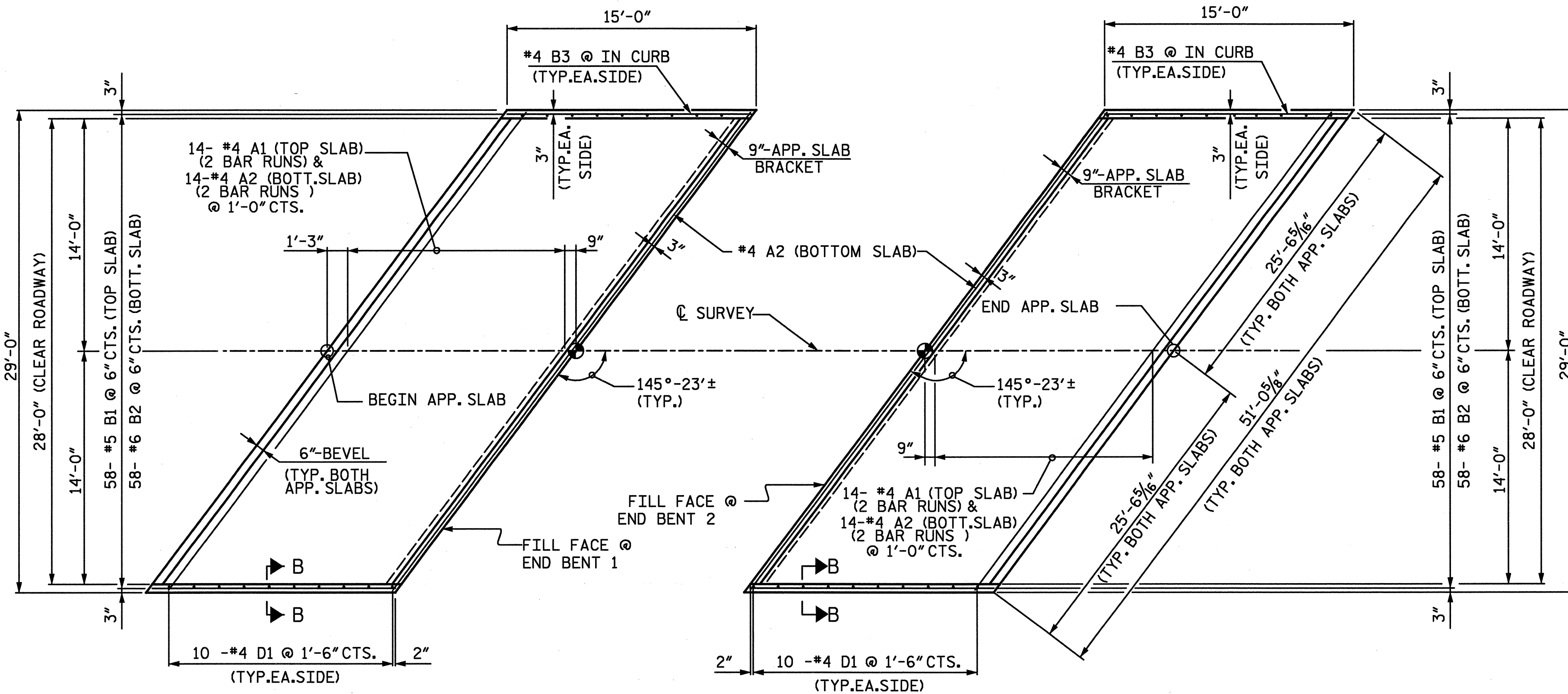

PLAN @ END BENT 1

PLAN @ END BENT 2

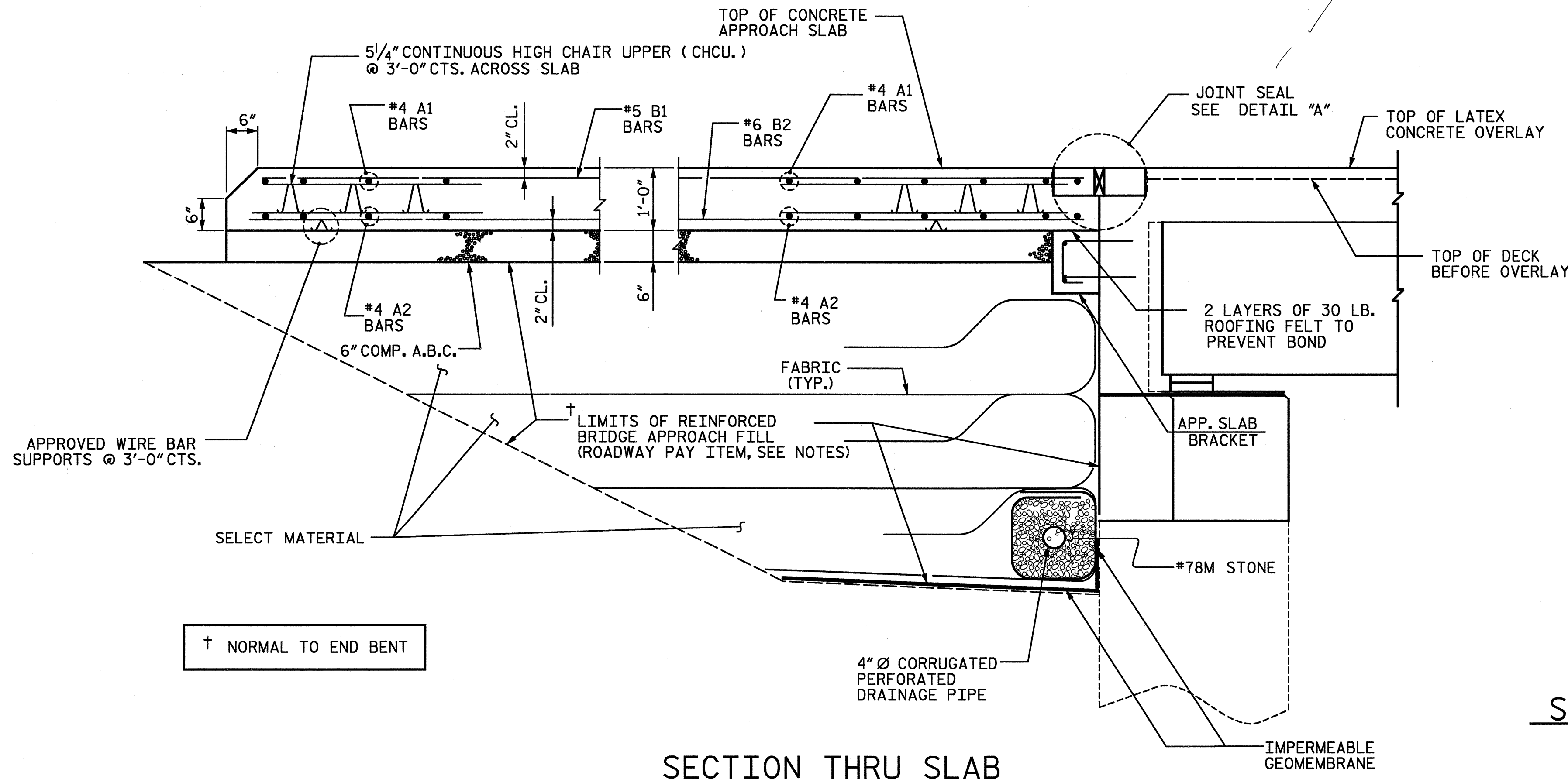

SECTION THRU SLAB

NOTES

FOR REINFORCED BRIDGE APPROACH FILL INCLUDING FABRIC, IMPERMEABLE GEOMEMBRANE, 4" Ø DRAINAGE PIPE, #78M STONE, AND SELECT MATERIAL, SEE STD. DWG. 422.10.

AREA BETWEEN THE WINGWALL AND APPROACH SLAB SHALL BE GRADED TO DRAIN THE WATER AWAY FROM THE FILL FACE OF THE BRIDGE AND SHALL BE PAVED. SEE STD. DWG. 422.10.

THE 6" COMP. A.B.C. SHALL BE FLUSH WITH THE END OF THE APPROACH SLAB AND 1'-0" OUTSIDE OF EACH EDGE OF SLAB.

THE CONTRACTOR MAY USE 4" TYPE B-25.0B ASPHALT CONCRETE BASE COURSE IN LIEU OF 6" COMP. A.B.C. IF THIS OPTION IS USED, THE BASE COURSE SHALL EXTEND 1'-0" BEYOND THE END OF THE APPROACH SLAB AND THE WIDTH SHALL BE THE SAME AS THAT OF THE APPROACH SLAB.

THE CONTRACTOR MAY USE 5" CLASS "A" CONCRETE BASE IN LIEU OF 6" COMP. A.B.C. IF THIS OPTION IS USED, THE CONCRETE BASE SHALL EXTEND 1'-0" BEYOND THE END OF THE APPROACH SLAB AND THE WIDTH SHALL BE THE SAME AS THAT OF THE APPROACH SLAB. THE CONCRETE SHALL BE FINISHED TO A SMOOTH SURFACE AND A LAYER OF 30 LB ROOFING FELT SHALL BE PLACED BETWEEN THE CONCRETE BASE AND THE APPROACH SLAB TO PREVENT BOND. THE APPROACH SLAB SHALL NOT BE CAST UNTIL THE CONCRETE BASE HAS REACHED AN AGE OF THREE CURING DAYS.

THE 6" BEVEL AT THE END OF THE APPROACH SLAB SHALL EXTEND FROM FRONT FACE OF CURB TO FRONT FACE OF CURB. FOR ELASTOMERIC CONCRETE, SEE SPECIAL PROVISIONS.

FOR EVAZOTE JOINT SEALS, SEE SPECIAL PROVISIONS.

EVAZOTE JOINT SEAL AND ELASTOMERIC CONCRETE SHALL BE PLACED AS SHOWN BETWEEN FACE OF CURB ONLY.

BILL OF MATERIAL					
ONE APP. SLAB (2 REQ'D)					
BAR	NO.	SIZE	TYPE	LENGTH	WEIGHT
*A1	28	#4	STR	26'-4"	403
A2	30	#4	STR	26'-3"	526
*B1	58	#5	STR	13'-8"	827
B2	58	#6	STR	14'-8"	1278
*B3	2	#4	STR	14'-8"	20
*D1	20	#4	STR	1'-0"	13
REINFORCING STEEL				lbs.	1804
*EPOXY COATED REINFORCING STEEL				lbs.	1356
CLASS AA CONCRETE					
POUR 1	SLAB		C. Y.		16.0
POUR 2	CURB		C. Y.		0.4
TOTAL CONCRETE				C. Y.	16.4
SPLICE CHART					
BAR SIZE	EPOXY COATED	UNCOATED			
#4	2'-0"	1'-9"			
#5	2'-6"	2'-2"			
#6	3'-10"	2'-7"			
ELASTOMERIC CONCRETE					
LOCATION	ELAST. CONCRETE (CU. FT.) *				
END BENT	9.0				
APP. SLAB	9.0				

*BASED ON MINIMUM BLOCKOUT SHOWN

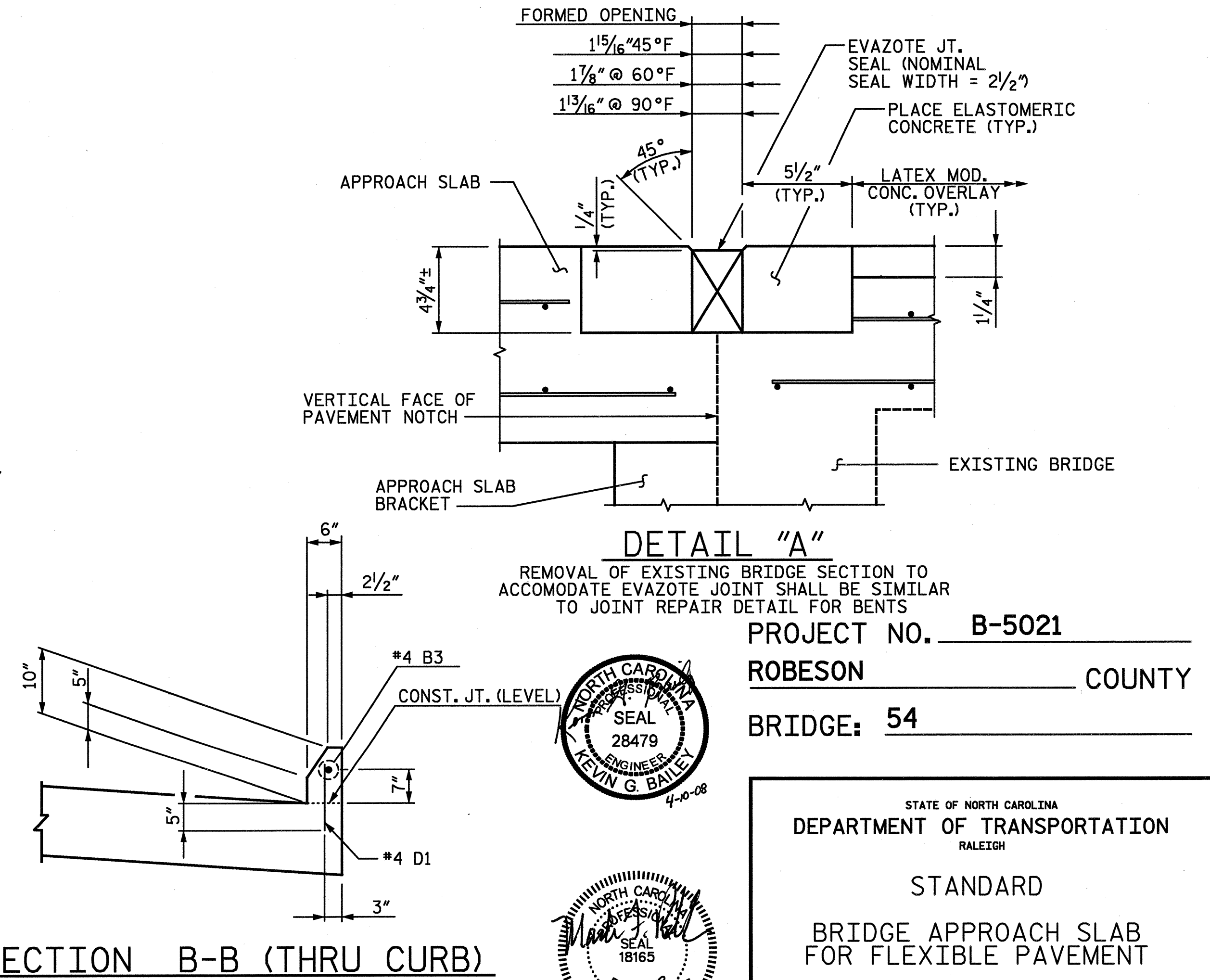

DETAIL "A"

SECTION B-B (THRU CURB)

REMOVAL OF EXISTING BRIDGE SECTION TO ACCOMMODATE EVAZOTE JOINT SHALL BE SIMILAR TO JOINT REPAIR DETAIL FOR BENTS

PROJECT NO. **B-5021**

ROBESON COUNTY

BRIDGE: **54**

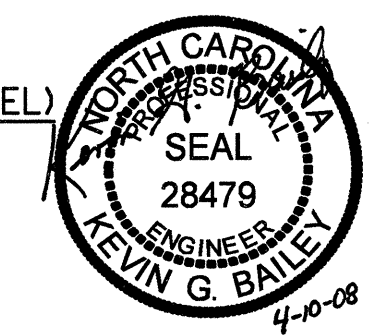

STATE OF NORTH CAROLINA
DEPARTMENT OF TRANSPORTATION
RALEIGH

STANDARD
BRIDGE APPROACH SLAB
FOR FLEXIBLE PAVEMENT

DRAWN BY: **TJT** DATE: **1-08**
CHECKED BY: **PEK** DATE: **3-08**

NOT TO SCALE

D-1809.19
STV/ Ralph Whitehead Associates, Inc.
1000 West Morehead St., Ste. 200
Charlotte, NC 28208

REVISIONS						SHEET NO.
NO.	BY:	DATE:	NO.	BY:	DATE:	
1			3			5-19
2			4			TOTAL SHEETS 62

NOTES

- FOR LATEX MODIFIED CONCRETE, SEE SPECIAL PROVISIONS.
- FOR REPAIR OF BRIDGE 100 DECK WITH LATEX MODIFIED CONCRETE, SEE SPECIAL PROVISIONS.
- FOR FALSEWORK AND FORMWORK, SEE SPECIAL PROVISIONS.
- FOR MAINTENANCE AND PROTECTION OF TRAFFIC BENEATH BRIDGE, SEE SPECIAL PROVISIONS.
- ALL DIMENSIONS IN THESE PLANS ARE BASED UPON BEST AVAILABLE INFORMATION. THE CONTRACTOR SHALL VERIFY DIMENSIONS IN FIELD PRIOR TO CONSTRUCTION AND ANY FABRICATION. CONTRACTOR SHALL NOTIFY THE ENGINEER OF ANY DISCREPANCIES SUCH THAT NECESSARY ADJUSTMENTS BE MADE BY THE CONTRACTOR.
- FOR SUBMITTAL OF WORKING DRAWINGS, SEE SPECIAL PROVISIONS.
- FOR CRANE SAFETY, SEE SPECIAL PROVISIONS.
- ALL STRUCTURAL STEEL SHALL BE ASTM A36 MIN.
- ALL WELDING SHALL BE IN ACCORDANCE WITH CURRENT AWS SPECIFICATIONS.

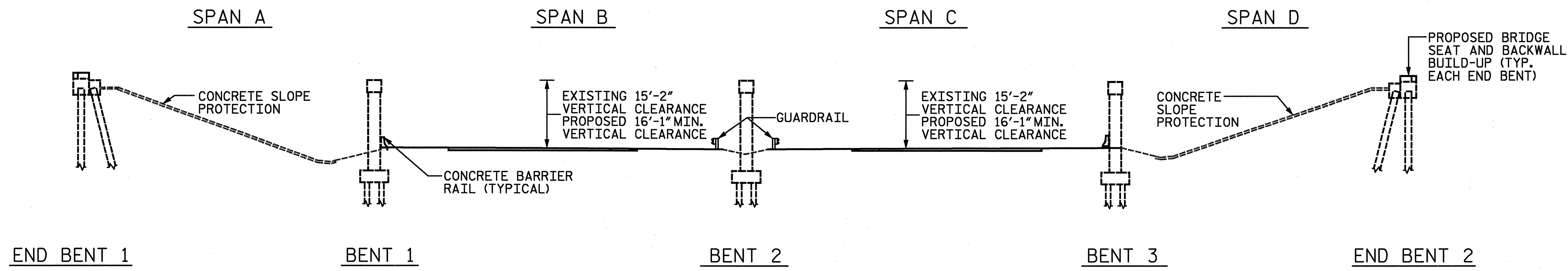

ELEVATION

SECTIONS AT BENTS AND END BENTS ARE AT RIGHT ANGLES.

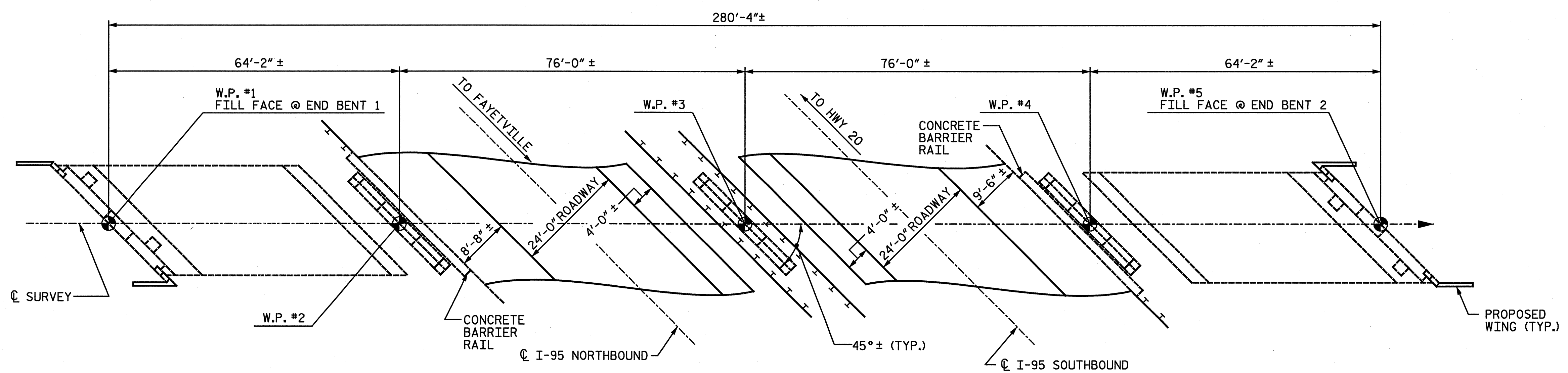

PLAN

△ TOTAL BILL OF MATERIAL

	PARTIAL REMOVAL OF EXISTING STRUCTURE	BRIDGE FLOOR GROOVING	CLASS AA CONCRETE	BRIDGE APPROACH SLABS	REINFORCING STEEL	STRUCTURAL STEEL*	CLASS I, SURFACE PREPARATION	CLASS II, SURFACE PREPARATION	LATEX MODIFIED CONCRETE OVERLAY	PLACING AND FINISHING OF LATEX MODIFIED CONCRETE OVERLAY	EPOXY RESIN INJECTION	EPOXY MORTAR REPAIRS	EVAZOTE JOINT SEALS	BRIDGE JACKING
	LUMP SUM	SQ. FT.	CU. YDS.	LUMP SUM	LBS.	APPROX. LBS.	SQ. YDS.	SQ. YDS.	CU. YDS.	SQ. YDS.	LINEAR FT.	SQ. FT.	LUMP SUM	LUMP SUM
SUPERSTRUCTURE	LUMP SUM	7,606	4.2	LUMP SUM		4584	870	60	29.7	853	20.0	16.0	LUMP SUM	LUMP SUM
END BENT 1	LUMP SUM		11.6		1890	68					2.0	3.5		
BENT 1												3.0		
BENT 2											21.0	4.0		
BENT 3												4.5		
END BENT 2	LUMP SUM		11.6		1890	68					2.0	3.5		
TOTAL	LUMP SUM	7,606	27.4	LUMP SUM	3780	4,720	870	60	29.7	853	45.0	34.5	LUMP SUM	LUMP SUM

* INCLUDES WEIGHT OF ANCHOR BOLTS

△ REVISION #1: REVISED PER REVIEW COMMENTS
 BY: TJT DATE: 5-08
 CH'KD BY: KGB DATE: 5-08

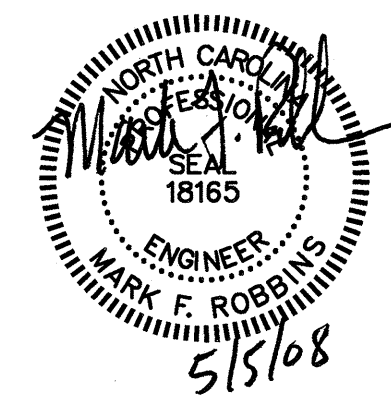
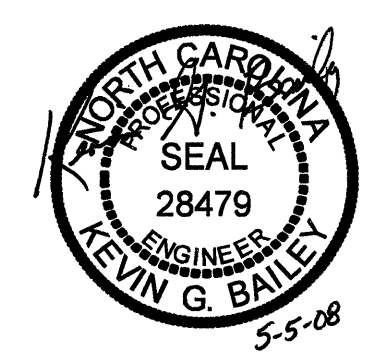

PROJECT NO. **B-5021**
ROBESON COUNTY
 BRIDGE: **100**

MODIFICATION OF BRIDGE NO. 100
 STATE OF NORTH CAROLINA
 DEPARTMENT OF TRANSPORTATION
 RALEIGH
GENERAL DRAWING
BRIDGE OVER I-95 ON
US 301
BETWEEN SR 1726 AND
HWY 20

REVISIONS						SHEET NO.
NO.	BY:	DATE:	NO.	BY:	DATE:	5-20
1	STV	5-08	3			TOTAL SHEETS 62
2			4			

D-1809.20
STV / Ralph Whitehead Associates, Inc.
 1000 West Morehead St., Ste. 200
 Charlotte, NC 28208

N:\PROJ\2513448\B5021\Roadway\Proj\Bridg\100\Structures\Station\Finals\Plan & Profile.dgn
 6:37:56 AM
 5/2/2008
 timothy.townsend

N:\PROJ\2513448\B5021\Bridg 100\Station\Finals\TypicalSection.dgn
 2:24:40 PM
 4/10/2008
 timothy.townsend

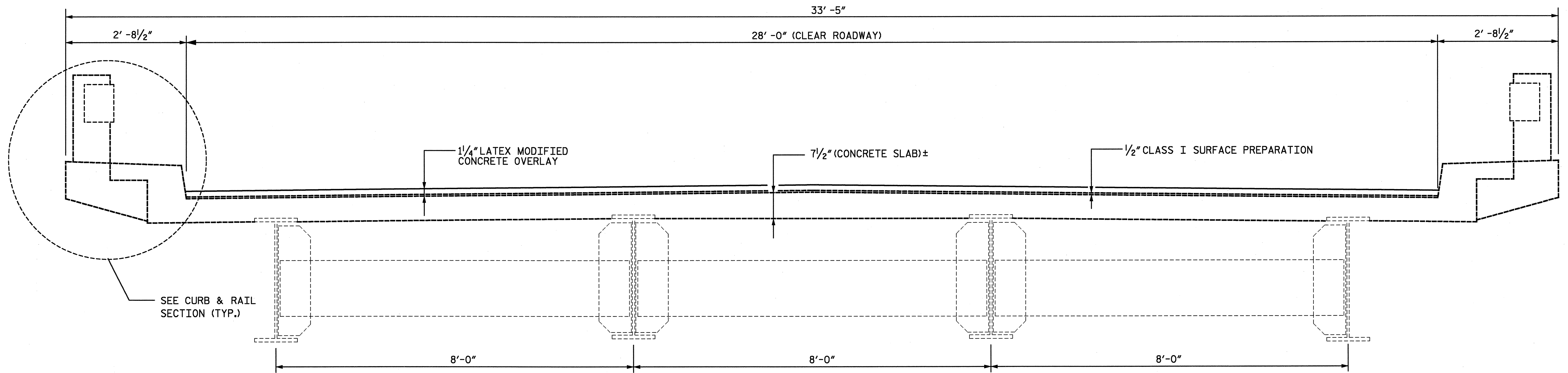

TYPICAL SECTION

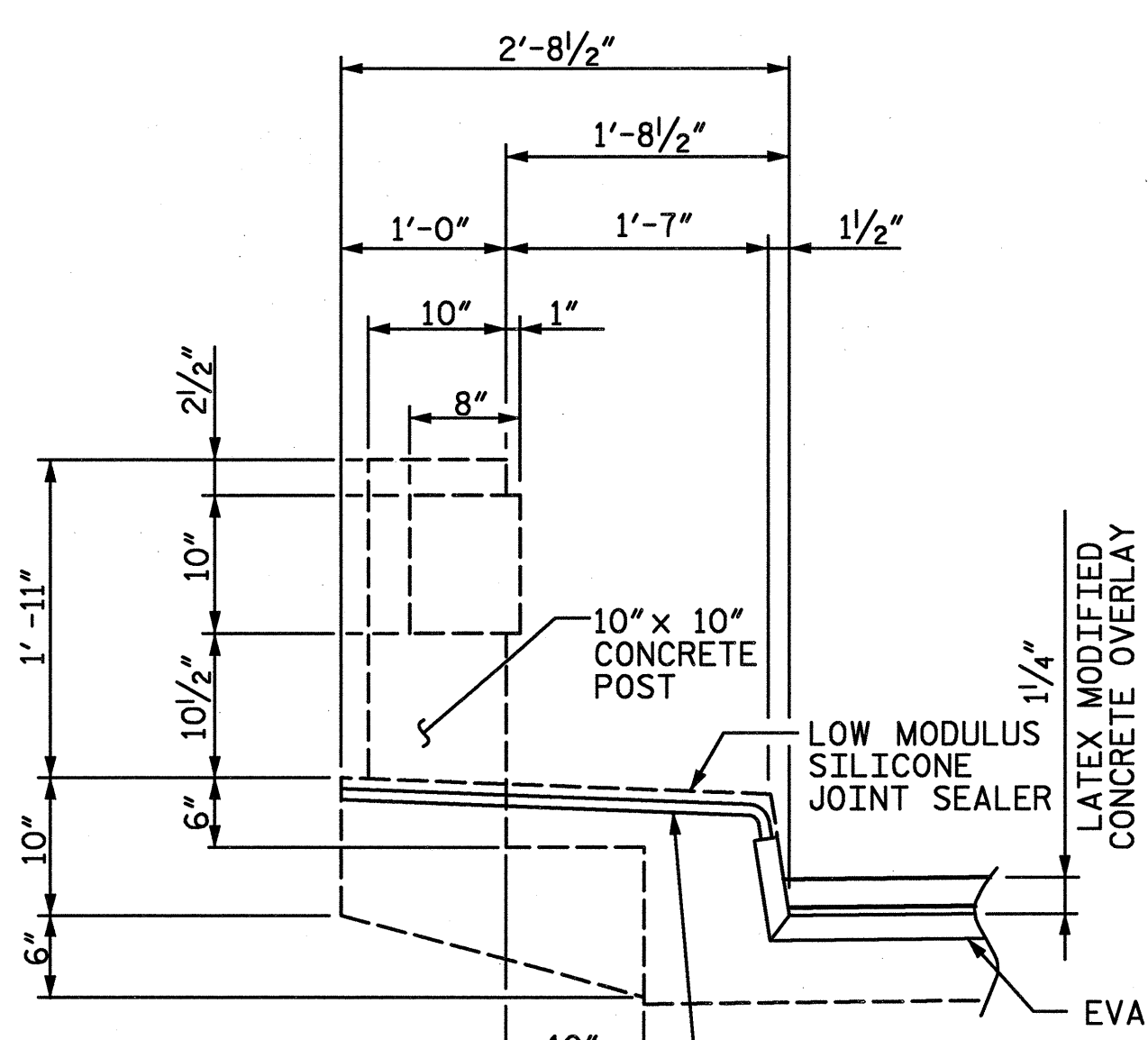

CURB AND RAIL SECTION *

* PER SIDE, THERE ARE 9 POSTS PER SPAN
 TOTAL RAIL LENGTH = 285'-5" PER SIDE

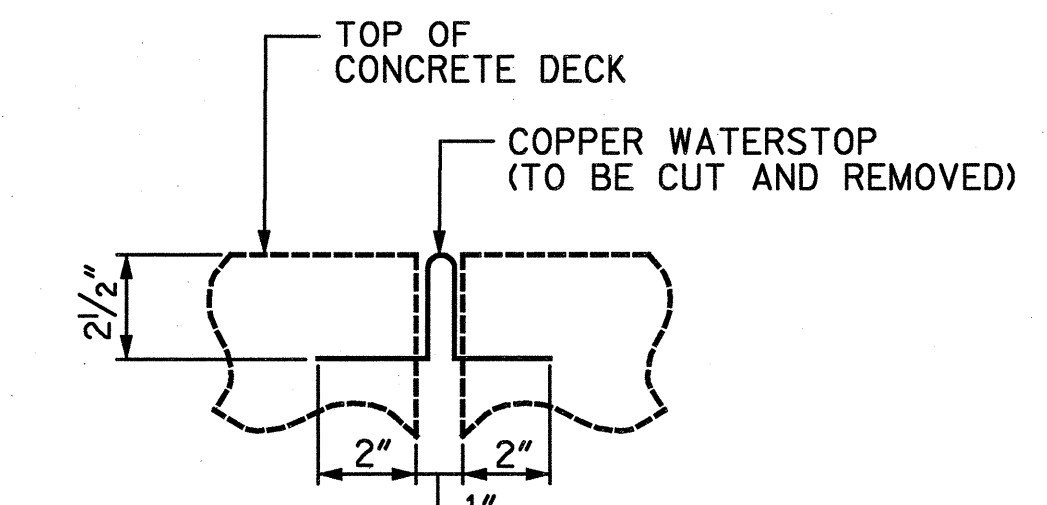

EXISTING EXPANSION JOINT DETAIL

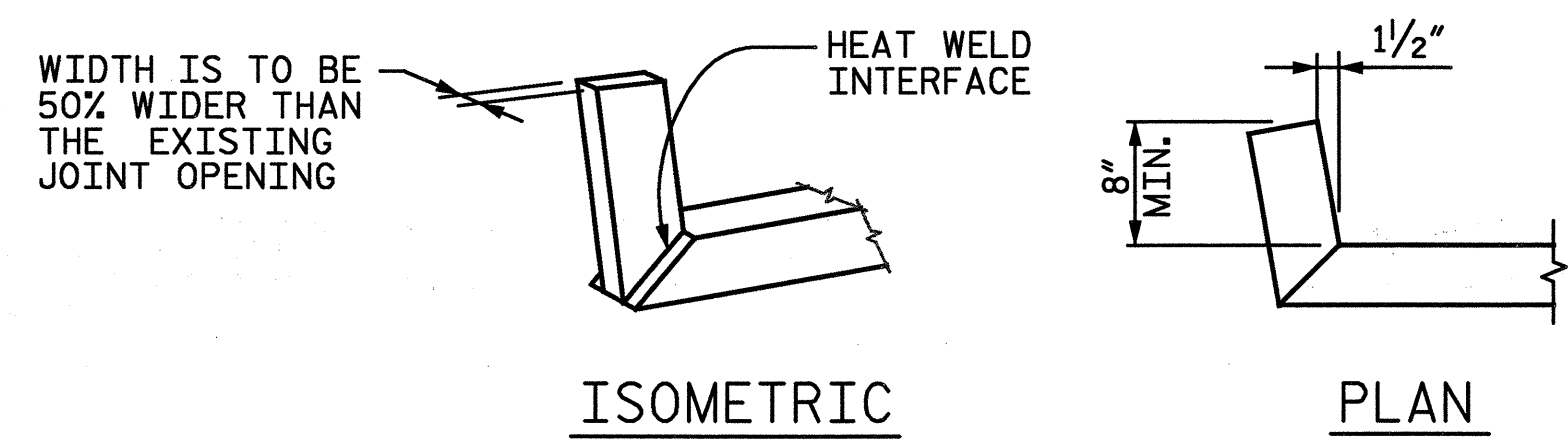

EVAZOTE JOINT DIRECTIONAL CHANGE DETAIL

HEAT WELD EVAZOTE MATERIAL PER MANUFACTURER'S RECOMMENDATIONS

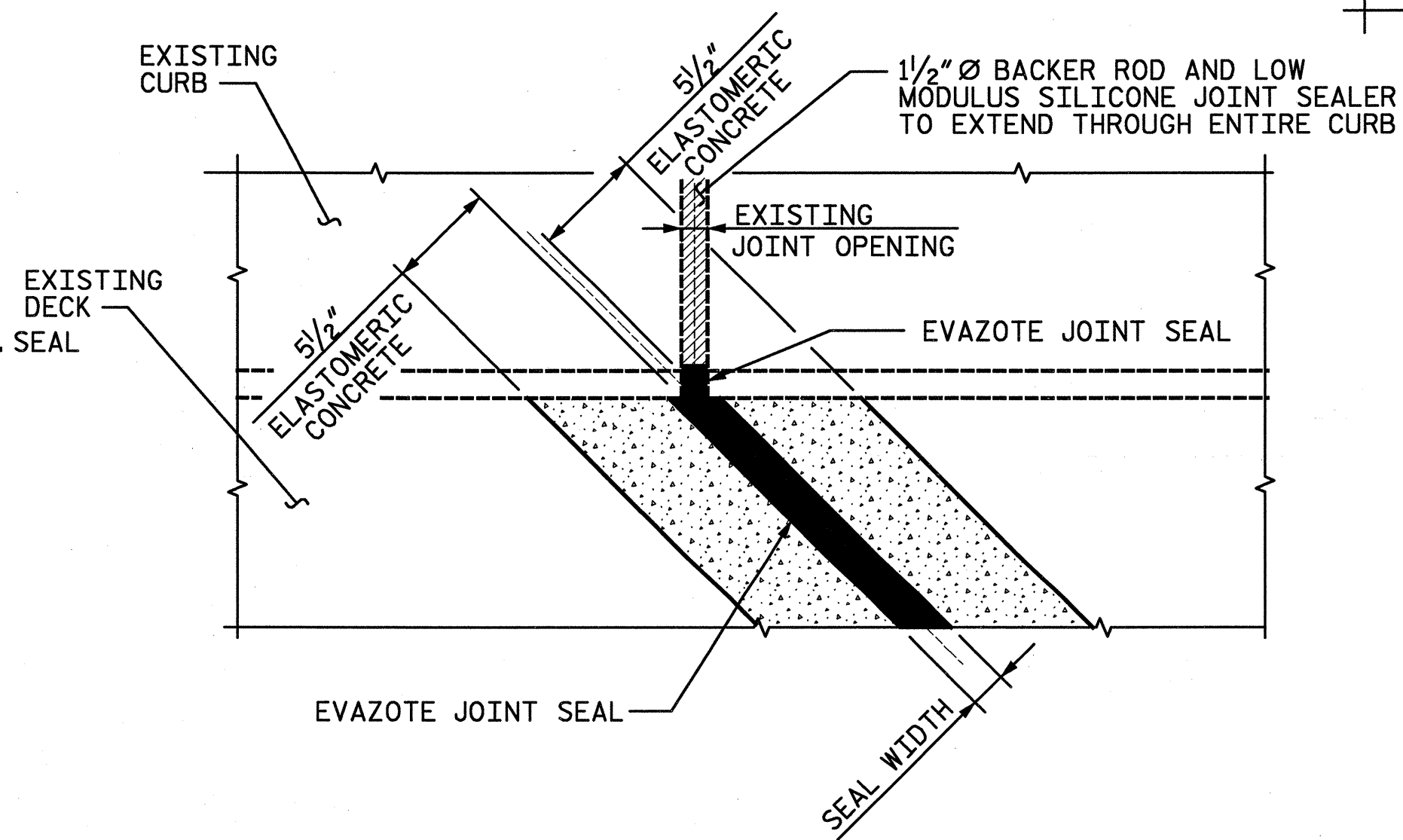

PLAN VIEW OF EVAZOTE JOINT @ GUTTERLINE

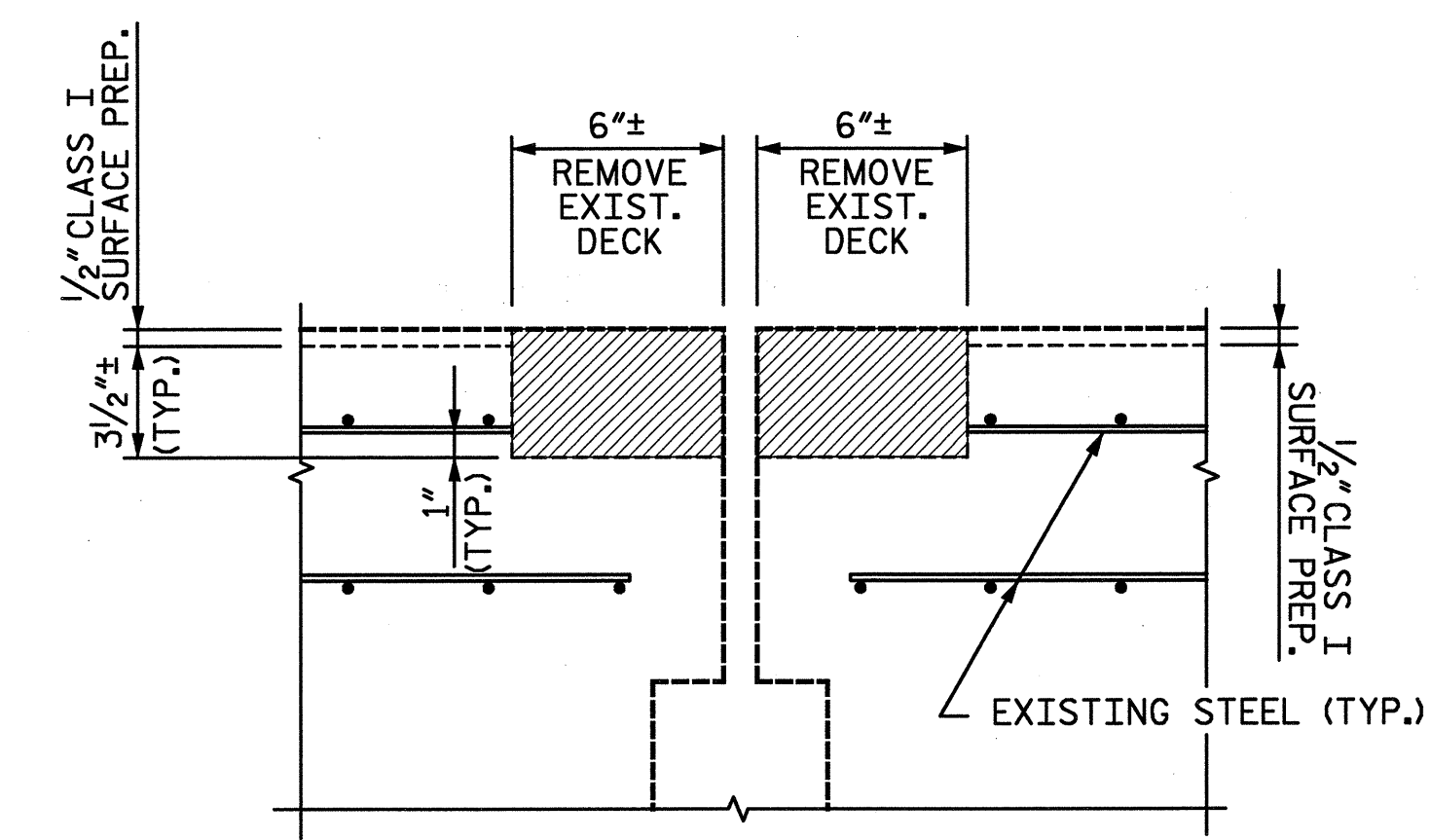

REMOVAL SECTION

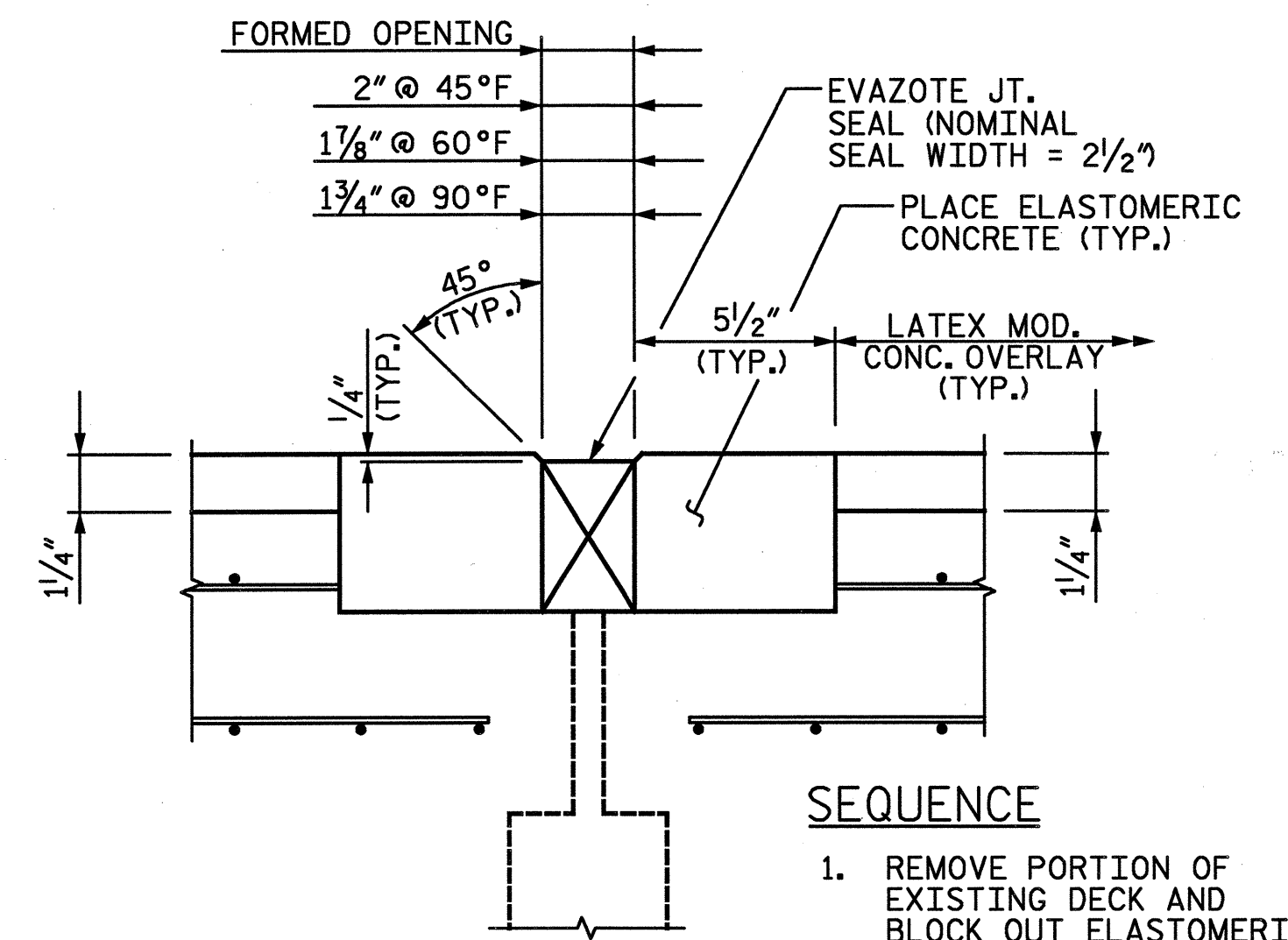

SEQUENCE

1. REMOVE PORTION OF EXISTING DECK AND BLOCK OUT ELASTOMERIC AREA.
2. PLACE LATEX MODIFIED CONCRETE. (ESTIMATED ELASTOMERIC CONCRETE = 1.2 C.Y.)
3. FORM JOINT AND POUR ELASTOMERIC CONCRETE.
4. REMOVE JOINT FORM.
5. INSTALL EVAZOTE JOINT.

PROJECT NO. **B-5021**
 ROBESON COUNTY
 BRIDGE: **100**

NOTES

1. FOR ELASTOMERIC CONCRETE, SEE SPECIAL PROVISIONS.
2. FOR EVAZOTE JOINT SEALS, SEE SPECIAL PROVISIONS.
3. PAYMENT FOR INSTALLATION OF THE 1/2" Ø BAKER ROD AND LOW MODULUS SILICONE JOINT SEALER SHALL BE CONSIDERED INCIDENTAL TO THE CONSTRUCTION OF THE BRIDGE.

BILL OF MATERIAL	
BENT NO.	ELASTOMERIC CONCRETE (CU. FT.) *
1	14.4
2	14.4
3	14.4

* BASED ON MINIMUM BLOCKOUT SHOWN

NOTE: SEE APPROACH SLAB FOR ELASTOMERIC CONCRETE AT END BENTS

JOINT REPAIR DETAIL

SECTIONS NORMAL TO JOINT AT BENT

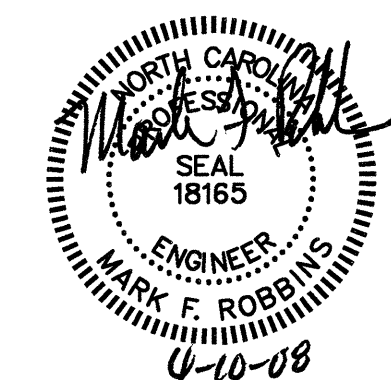
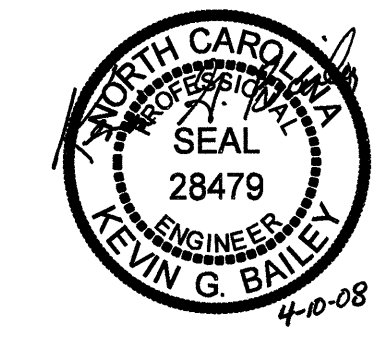

STATE OF NORTH CAROLINA
 DEPARTMENT OF TRANSPORTATION
 RALEIGH
 EXISTING SUPERSTRUCTURE
 TYPICAL SECTION

REVISIONS						SHEET NO.
NO.	BY:	DATE:	NO.	BY:	DATE:	S-21
1			3			TOTAL SHEETS
2			4			62

NOT TO SCALE

D-1809.21
 STV/ Ralph Whitehead Associates, Inc.
 1000 West Morehead St., Ste. 200
 Charlotte, NC 28208

N:\PROJ\2513448\B5021\Roadway\Proj\Bridges\100\Structures\Ustation\Finals\Bridg Jacking.dgn
 6:37:31 AM
 timothy.townsend 5/2/2008

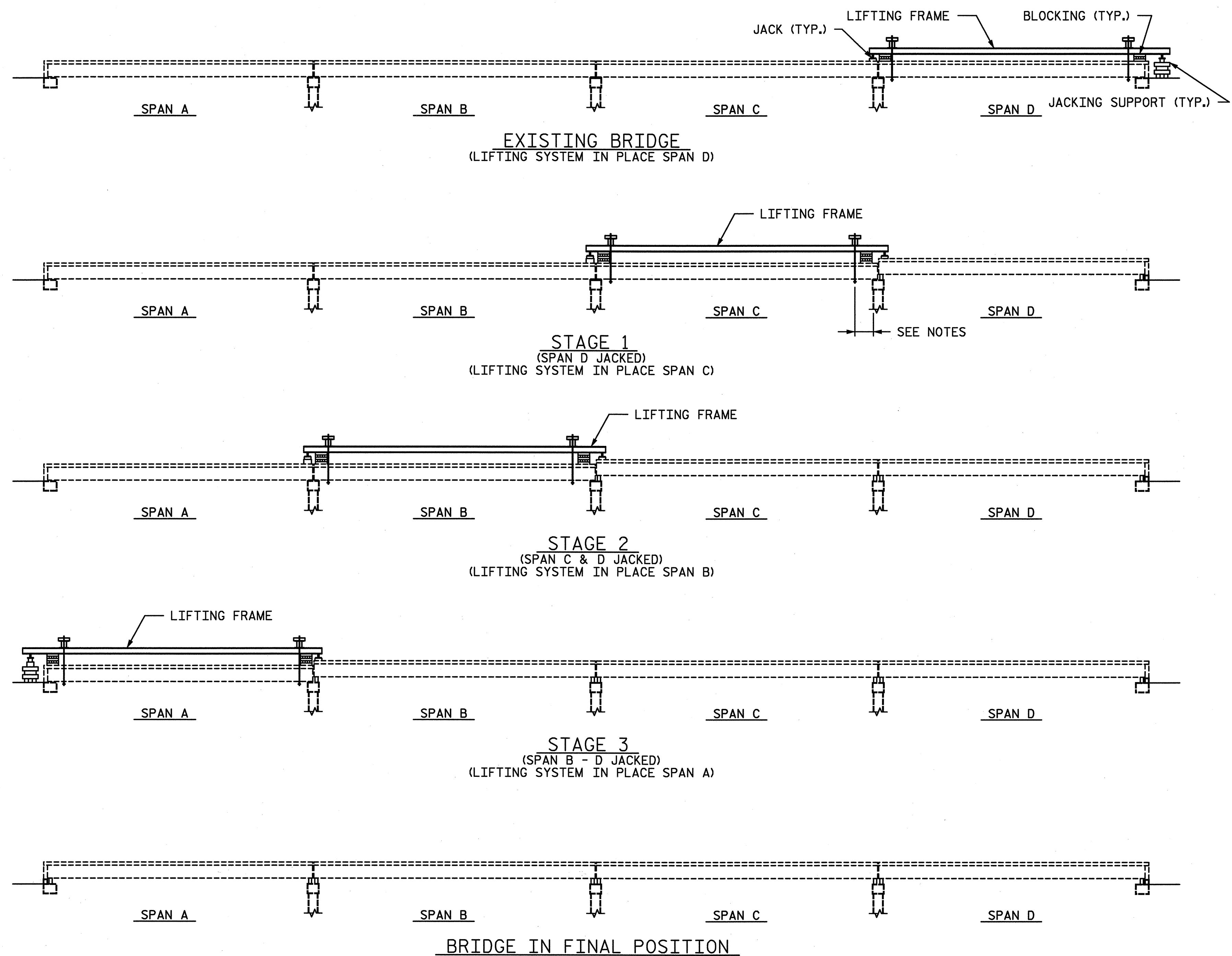

JACKING SEQUENCE FOR BRIDGE 100

NOTES:

1. THE CONTRACTOR SHALL JACK ALL BEAMS IN ANY ONE SPAN SIMULTANEOUSLY.
2. TRAFFIC SHALL NOT BE ALLOWED ON THE STRUCTURE UNTIL THE WORK REQUIRED BY THE CONTRACT DOCUMENTS IS COMPLETE.
3. PRIOR TO INSTALLING BEARING PEDESTALS AND NEW BEARINGS, CONTRACTOR SHALL MAKE ANY REPAIRS TO BENTS AS REQUIRED IN THE CONTRACT DOCUMENTS.
4. CONTRACTOR SHALL SUBMIT JACKING PLANS AND CALCULATIONS SEALED BY A PROFESSIONAL ENGINEER REGISTERED IN THE STATE OF NORTH CAROLINA FOR REVIEW AND APPROVAL PRIOR TO MATERIAL PURCHASE OR FABRICATION OF JACKING SYSTEM.
5. FOR ADDITIONAL INFORMATION ON JACKING SEE SPECIAL PROVISION "BRIDGE JACKING".
6. LIFTING FRAME SHALL EXTEND BEYOND THE LENGTH OF THE LIFTED SPAN AND PROVIDE BEARINGS AT THE SAME LOCATION AS THE ADJACENT GIRDER BEARINGS.
7. CONTRACTOR SHALL SHIM BRIDGE SPAN DURING JACKING SUCH THAT THE MAXIMUM UNSHIMMED LIFT IS 1".
8. CONTRACTOR SHALL PROVIDE SPAN LIFT POINTS AS CLOSE AS POSSIBLE TO THE FACE OF BENT CAP.
9. HYDRAULIC SYSTEM SHALL BE CONNECTED SUCH THAT ALL JACKS LIFT SIMULTANEOUSLY.
10. CONTRACTOR SHALL DESIGN LIFTING SYSTEM SUCH THAT HORIZONTAL POSITION OF THE LIFTED SPAN CAN BE MAINTAINED.

CONSTRUCTION SEQUENCE:

1. CONSTRUCT JACKING SUPPORT AT END BENT. CONTRACTOR SHALL MAKE SURE CURTAIN WALL IS FULLY DETACHED FROM END BENT CAP, WINGS, AND FILL.
2. CONSTRUCT THE LIFTING FRAME (FOR SPAN D) MAKING SURE SYSTEM IS LEVEL. INSTALL BLOCKING AS NECESSARY.
3. LIFT SPAN D TO REQUIRED ELEVATION AND INSTALL BEARING PEDESTALS AND NEW BEARINGS. PRIOR TO INSTALLING BEARING PEDESTALS AND NEW BEARINGS, CONTRACTOR SHALL MAKE ANY REPAIRS TO BENTS AS REQUIRED IN THE CONTRACT DOCUMENTS.
4. CONSTRUCT END BENT AND BENT MODIFICATIONS AS SHOWN IN THE CONTRACT DOCUMENTS. END BENT MODIFICATIONS NECESSARY TO ANCHOR THE SPAN SHALL BE COMPLETED PRIOR TO PROCEEDING.
5. SHIFT LIFT SYSTEM TO SPAN C AND REPEAT STEPS 2 THROUGH 4.
6. SHIFT LIFT SYSTEM TO SPAN B AND REPEAT STEPS 2 THROUGH 4.
7. SHIFT LIFT SYSTEM TO SPAN A AND REPEAT STEPS 1 THROUGH 4.
8. PREPARE DECK AND PLACE LATEX MODIFIED CONCRETE OVERLAY.
9. FINISH REMAINING REPAIRS AND MODIFICATIONS AS INDICATED IN CONTRACT DOCUMENTS. REMOVE TRAFFIC CONTROL MEASURES AND OPEN BRIDGE TO TRAFFIC.

REVISION #1: REVISED PER REVIEW COMMENTS
 BY: TJT DATE: 5-08
 CH'KD BY: KGB DATE: 5-08

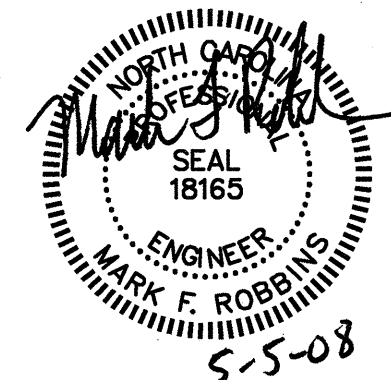
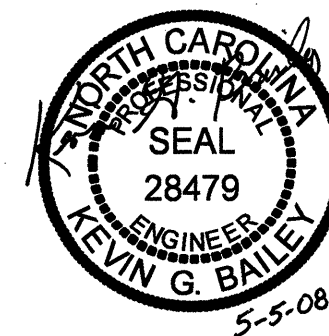

PROJECT NO. B-5021
 ROBESON COUNTY
 BRIDGE: 100

STATE OF NORTH CAROLINA DEPARTMENT OF TRANSPORTATION RALEIGH						BRIDGE JACKING SEQUENCE	
REVISIONS							SHEET NO.
NO.	BY:	DATE:	NO.	BY:	DATE:	TOTAL SHEETS	
1	STV	5-08	3			62	
2			4				

DRAWN BY: TJT DATE: 3-08
 CHECKED BY: MFR DATE: 3-08

D-1809.22
 STV/Ralph Whitehead Associates, Inc.
 1000 West Morehead St., Ste. 200
 Charlotte, NC 28208

N:\PROJ\2513448\B5021\Roadway\Proj\Bridg\100\Structures\Ustairion\Final\Substructure Interior Bent.dgn
 124347 PM 5/5/2008
 timothy.townsend

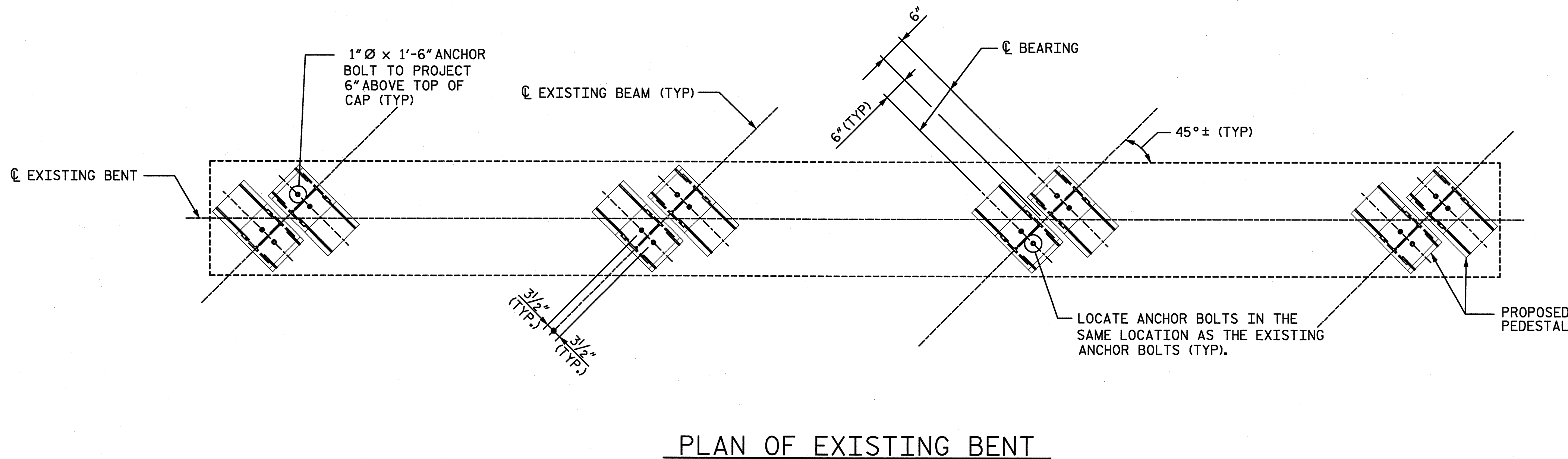

PLAN OF EXISTING BENT

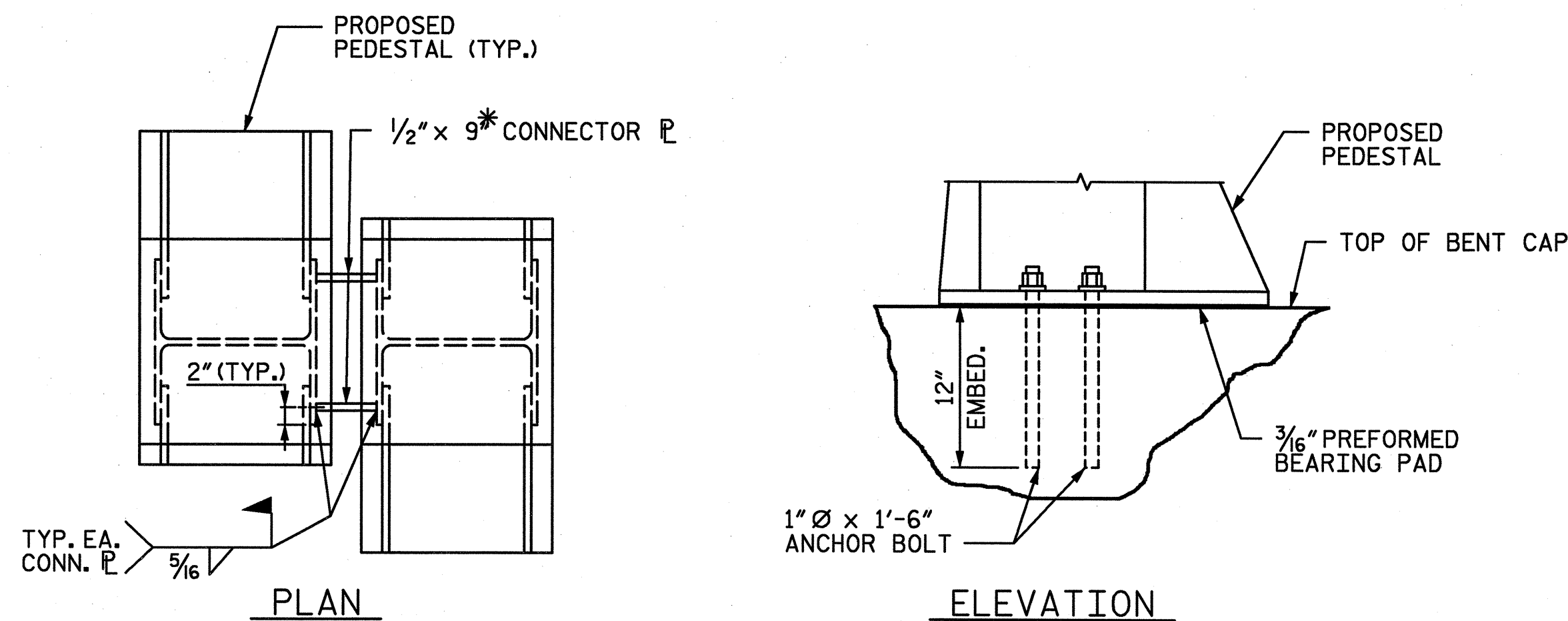

PEDESTAL ATTACHMENT DETAIL

(CONNECTOR PLATES SHALL BE INSTALLED AFTER BEARING ASSEMBLIES HAVE BEEN INSTALLED)

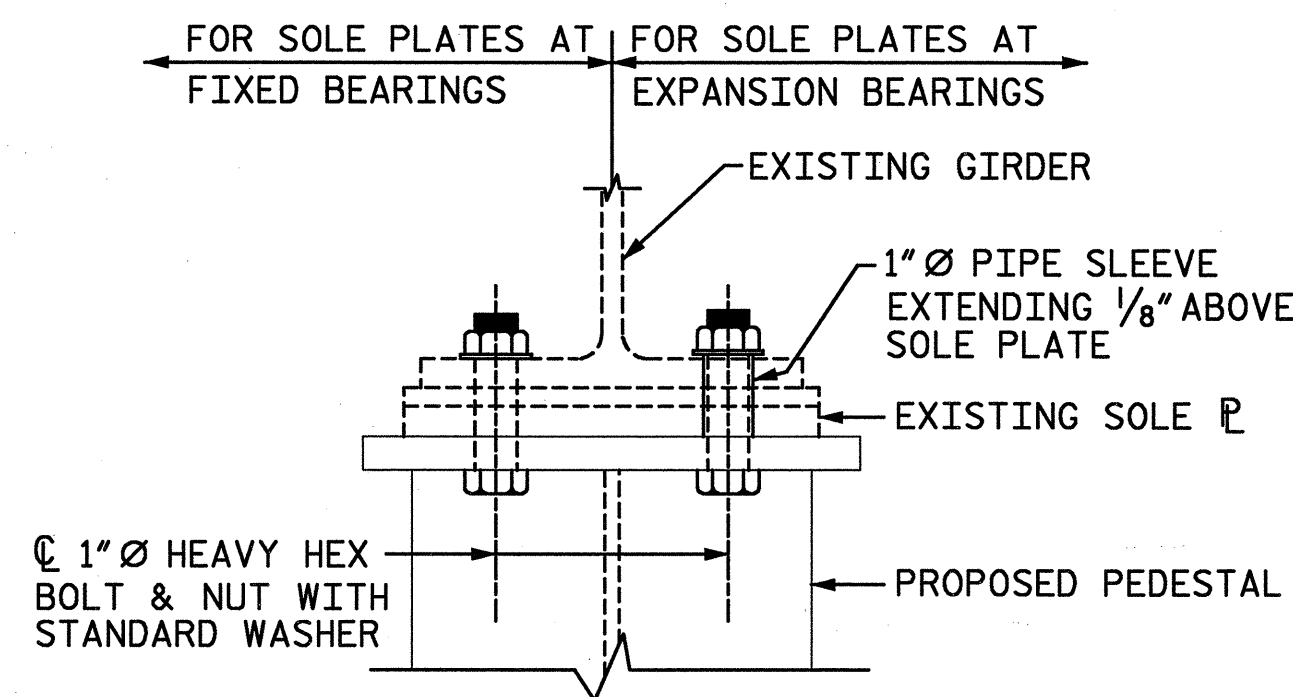

BEARING ATTACHMENT DETAIL

(CONTRACTOR SHALL VERIFY BOLT DIMENSION AND ADJUST HOLE DIAMETER AS NECESSARY PRIOR TO PEDESTAL FABRICATION)

STRUCTURAL STEEL
(APPROX. LBS. 4584)

NOTES

THE EXISTING ANCHOR BOLTS SHALL BE CUT FLUSH WITH THE EXISTING TOP OF CAP. ANCHOR BOLTS SHALL BE DRILLED AND ADHESIVELY ANCHORED INTO THE EXISTING CAP. CONTRACTOR SHALL CORE DRILL THE EXISTING ANCHOR BOLTS USING A CORE BIT WITH INSIDE DIAMETER MATCHING THAT OF THE EXISTING ANCHOR BOLT DIAMETER. THE ANCHOR BOLT HOLES IN THE PROPOSED TOP AND BOTTOM PLATE DETAIL SHALL MATCH THE ANCHOR BOLT HOLES IN THE EXISTING BEAMS. THIS MATCH SHALL FACILITATE THE PROPER ALIGNMENT OF THE PEDESTAL. THE ANCHOR BOLT LENGTH IS BASED ON AN 12" EMBEDMENT INTO THE EXISTING CAP AND MAY BE ADJUSTED BASED ON THE MINIMUM EMBEDMENT SPECIFIED BY THE MANUFACTURER OF THE EPOXY ADHESIVE BONDING SYSTEM. FOR ADHESIVELY ANCHORED ANCHOR BOLTS, SEE SPECIAL PROVISIONS.

THE CONTRACTOR SHALL FIELD VERIFY PROPOSED ANCHOR BOLT LOCATIONS PRIOR TO FABRICATION OF THE TOP AND BOTTOM PLATES FOR THE PROPOSED PEDESTALS.

FOR CLEANING AND PAINTING EXISTING BEARING PLATES, SEE SPECIAL PROVISION.

* THE PROPOSED PEDESTAL HEIGHT ASSUMES THAT THE TOTAL HEIGHT OF THE EXISTING BEARING ASSEMBLIES IS 2 1/2". THE CONTRACTOR SHALL MEASURE THE HEIGHT OF ALL BEARING ASSEMBLIES AND ADJUST THE HEIGHT OF THE PROPOSED PEDESTALS ACCORDINGLY.

ALL THREADS OF BOLTS/ANCHOR BOLTS SHALL BE BURRED AFTER TIGHTENING NUTS.

1" Ø BOLTS IN TOP PLATE SHALL CONFORM TO ASTM A325.

1" Ø ANCHOR BOLTS SHALL BE IN ACCORDANCE WITH THE STANDARD SPECIFICATIONS. CONTRACTOR SHALL VERIFY ANCHOR BOLT DIAMETER AND ADJUST AS NECESSARY TO MATCH EXISTING ANCHOR BOLT DIAMETER.

PROPOSED PEDESTALS SHALL BE GALVANIZED IN ACCORDANCE WITH SECTION 1076 OF THE STANDARD SPECIFICATIONS. AREAS TO BE WELDED SHALL BE REPAIRED IN ACCORDANCE WITH THE STANDARD SPECIFICATIONS.

REVISION #1: REVISED PER REVIEW COMMENTS
 BY: TJT DATE: 5-08
 CH'KD BY: KGB DATE: 5-08

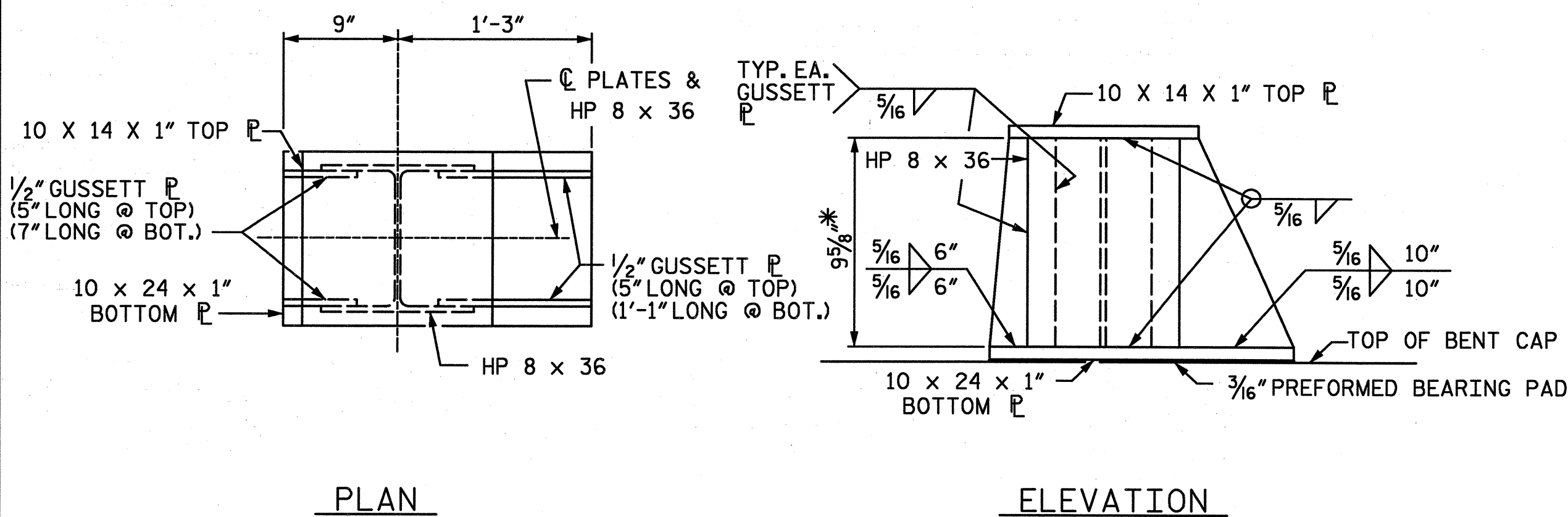

PEDESTAL DETAILS

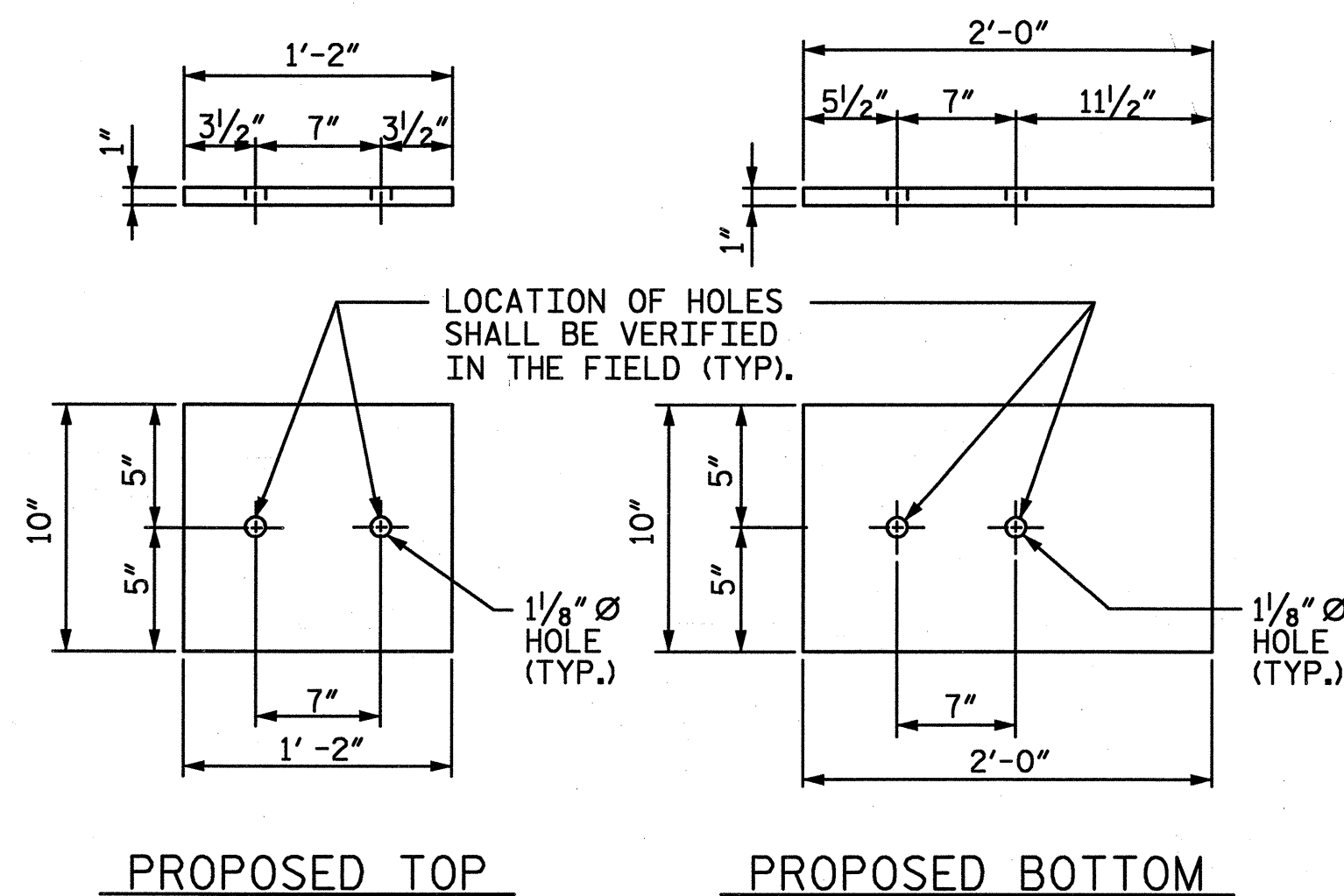
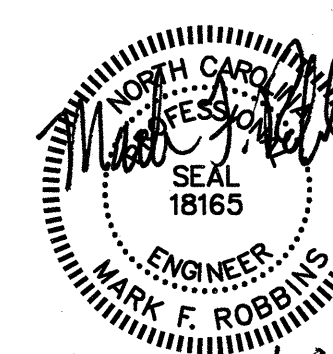
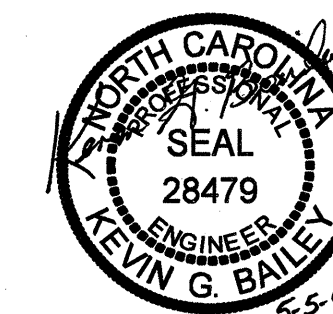

PLATE DETAIL

PROJECT NO. **B-5021**
 ROBESON COUNTY
 BRIDGE: **100**



STATE OF NORTH CAROLINA
 DEPARTMENT OF TRANSPORTATION
 RALEIGH
 SUBSTRUCTURE
 INTERIOR BENT
 BEARING MODIFICATIONS

REVISIONS

NO.	BY:	DATE:	NO.	BY:	DATE:
1	STV	5-08	3		
2			4		

SHEET NO.

5-23
 TOTAL SHEETS
 62

D-1809.23

NOT TO SCALE

STV / Ralph Whitehead Associates, Inc.
 1000 West Morehead St., Ste. 200
 Charlotte, NC 28208

5/5/08

I:\projects\2513448\B5021\Bridg 100\Station\Finals\Substructure Repairs.dgn
 11:03:57 AM
 4/10/2008
 timothy.townsend

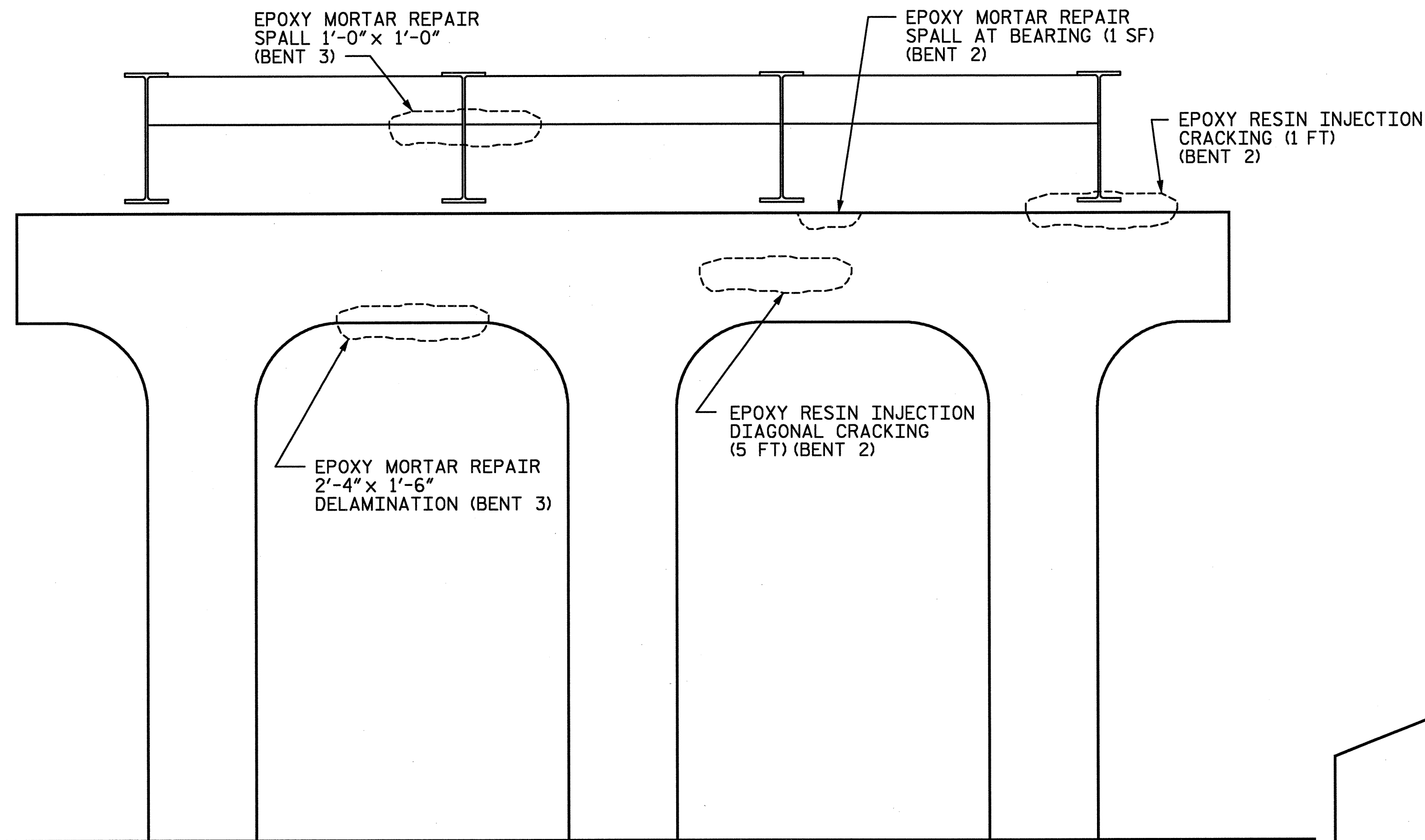

BENT ELEVATION

(LOOKING SOUTH)
(@ NORTH FACE)

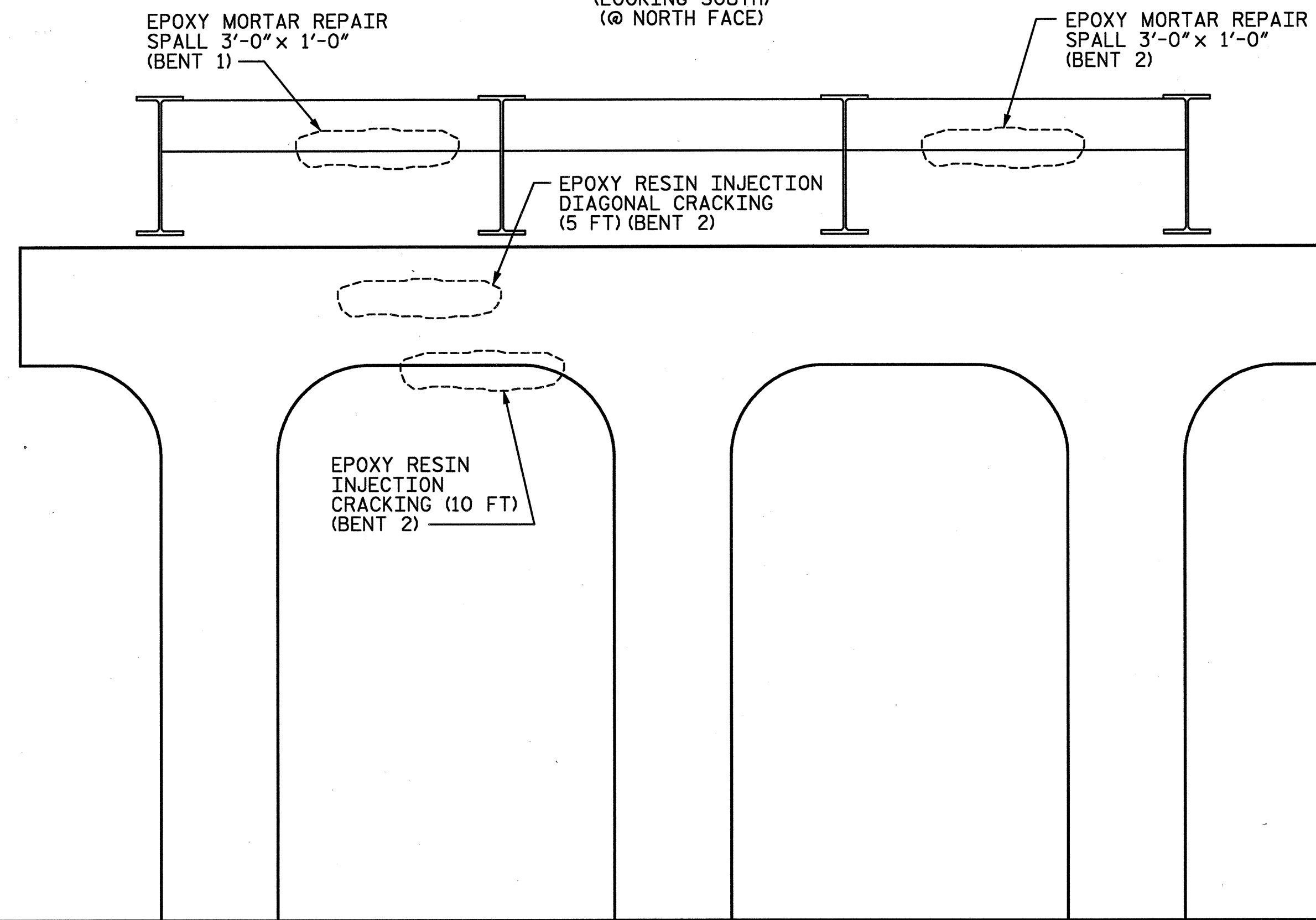

BENT ELEVATION

(LOOKING NORTH)
(@ SOUTH FACE)

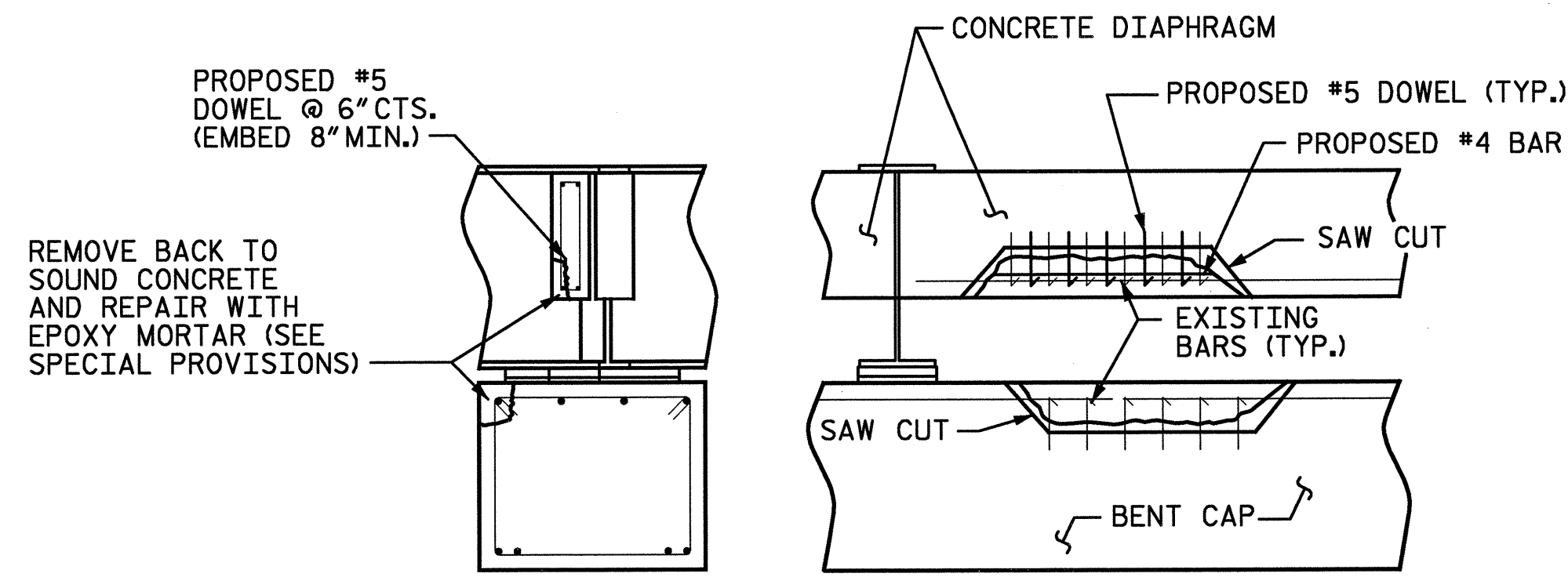

SECTION

ELEVATION

TYPICAL BENT AND DIAPHRAGM REPAIR DETAIL

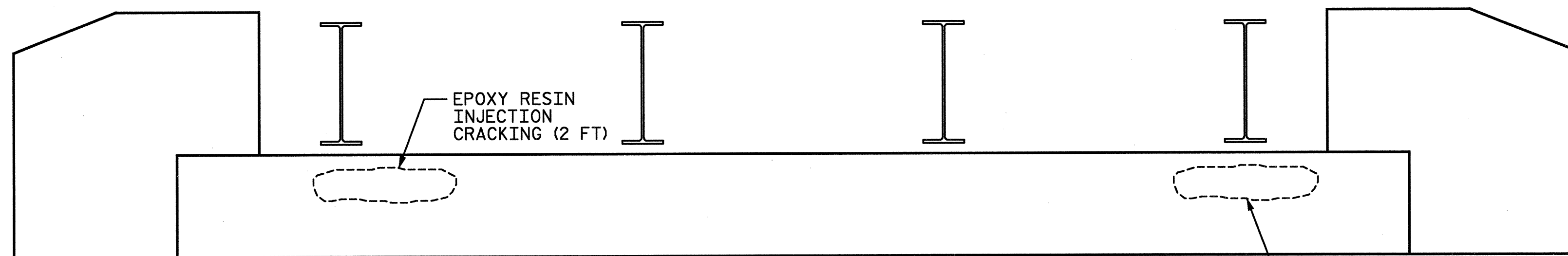

END BENT 1 ELEVATION

(FACING END BENT)

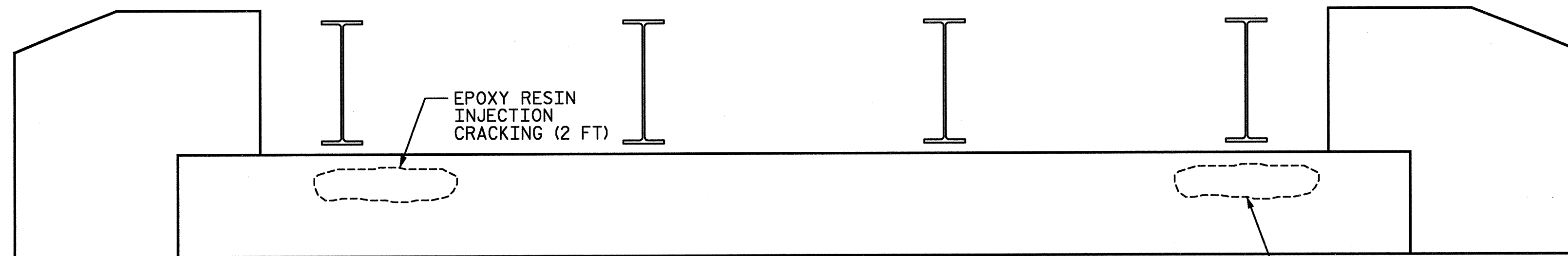

END BENT 2 ELEVATION

(FACING END BENT)

NOTES:

- REPAIRS SHALL BE IMPLEMENTED WHEN BRIDGE IS RAISED ABOVE REPAIR.
- BLOCKING SHALL NOT BE POSITIONED OVER REPAIR UNTIL REPAIR HAS CURED.
- SAWCUT 1/4" - 1/2" DEEP AROUND ALL SPALLS.
- FOR EPOXY RESIN INJECTION, SEE SPECIAL PROVISIONS.
- FOR EPOXY MORTAR REPAIR, SEE SPECIAL PROVISIONS.
- CONTRACTOR SHALL EPOXY MORTAR REPAIR 1 S.F. SPALL IN SPAN A UNDER THE DECK.
- CONTRACTOR SHALL EPOXY MORTAR REPAIR DELAMINATION IN SPAN D RIGHT SIDE OVERHANG AT 2 LOCATIONS. REPAIRS ARE APPROXIMATELY 6 S.F. AND 2 S.F.

PROJECT NO. **B-5021**
 ROBESON COUNTY
 BRIDGE: **100**

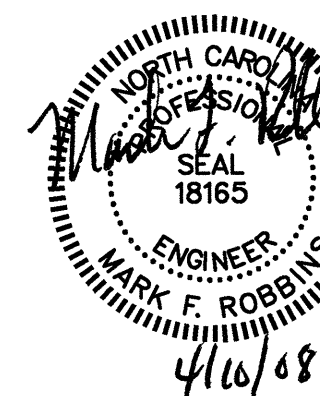
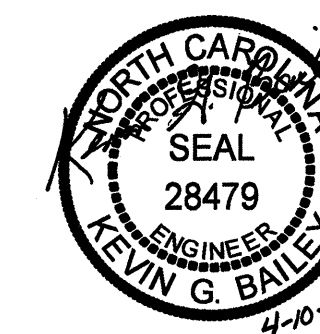

STATE OF NORTH CAROLINA
DEPARTMENT OF TRANSPORTATION
RALEIGH

SUBSTRUCTURE
REPAIRS

DRAWN BY: **KCB** DATE: **3-08**
 CHECKED BY: **MFR** DATE: **3-08**

D-1809.24
 STV/Ralph Whitehead Associates, Inc.
 1000 West Morehead St., Ste. 200
 Charlotte, NC 28208

REVISIONS						SHEET NO.	
NO.	BY:	DATE:	NO.	BY:	DATE:	S-24	
1			3			TOTAL SHEETS	
2			4			62	

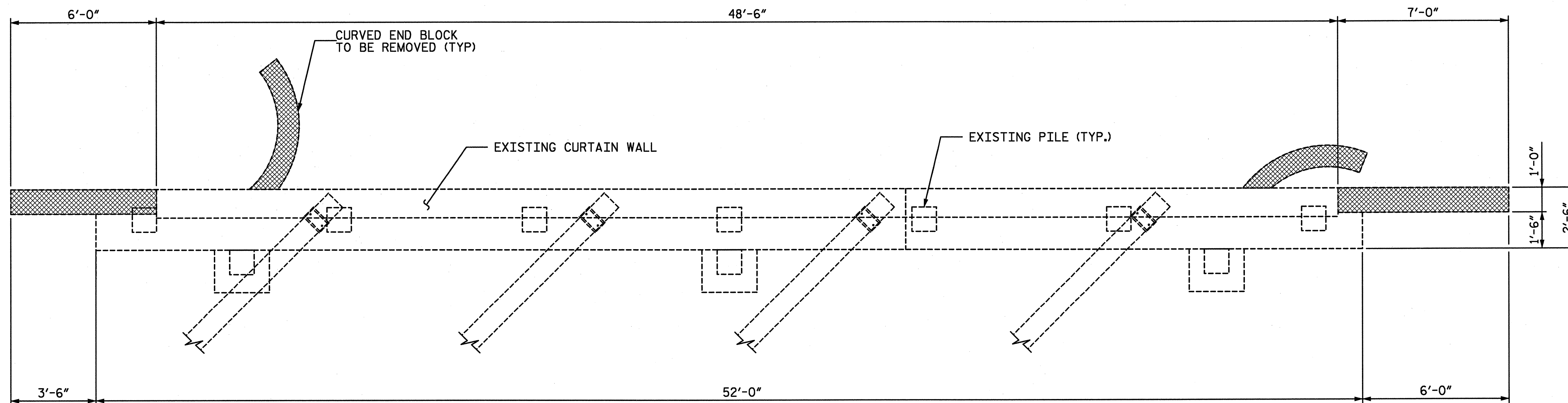

PLAN OF EXISTING CAP

END BENT 2 SHOWN, END BENT 1 SIMILAR

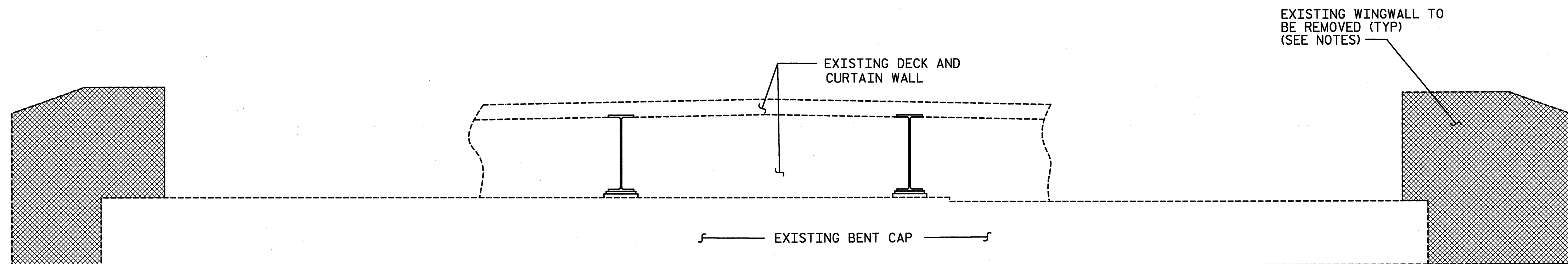

ELEVATION OF EXISTING CAP

END BENT 2 SHOWN, END BENT 1 SIMILAR
CURVED END BLOCK NOT SHOWN

NOTES

DIMENSIONS ARE BASED ON BEST AVAILABLE INFORMATION. CONTRACTOR SHALL FIELD VERIFY DIMENSIONS PRIOR TO CONSTRUCTION.

PORTIONS OF EXISTING END BENT SHOWN IN CROSS-HATCHED AREAS SHALL BE REMOVED.

VERTICAL AND HORIZONTAL REINFORCING STEEL EXTENDING FROM THE END BENT CAP INTO THE EXISTING WINGWALLS SHALL BE CLEANED AND STRAIGHTENED. CUT EXISTING REINFORCING STEEL TO MAINTAIN REQUIRED CONCRETE COVER. MINIMUM 14" EXTENSION INTO THE PROPOSED WINGWALL.

BARS DAMAGED DURING THE CONCRETE REMOVAL SHALL BE REPLACED BY #6 DOWELS SECURED IN THE EXISTING END BENT CAP WITH EPOXY ADHESIVE AT NO ADDITIONAL PAYMENT.

THE #6 DOWEL LENGTH SHALL BE BASED ON A 9" EMBEDMENT INTO EXISTING CONCRETE AND MAY BE ADJUSTED BASED ON THE MINIMUM EMBEDMENT SPECIFIED BY THE MANUFACTURER OF THE EPOXY ADHESIVE BONDING SYSTEM. SEE SPECIAL PROVISION FOR ADHESIVELY ANCHORED ANCHOR BOLTS OR DOWELS.

EXISTING ANCHOR BOLTS ARE TO BE CUT FLUSH WITH THE EXISTING TOP OF CAP.

THE EXISTING CURTAIN WALL CONCRETE AROUND ANCHOR BOLTS AND BEARING ASSEMBLIES SHALL BE REMOVED, USING HAND TOOLS, AS NECESSARY TO FREE ANCHOR BOLTS AND BEARING ASSEMBLIES. THE CONTRACTOR SHALL EXERCISE CARE DURING THE REMOVAL OF EXISTING CONCRETE TO INSURE THAT EXISTING GIRDERS, BEARING ASSEMBLIES AND CURTAIN WALL STEEL REMAIN UNDAMAGED.

CONTRACTOR SHALL REMOVE EXISTING APPROACH SLAB BRACKET AS NECESSARY TO ACCOMMODATE PROPOSED APPROACH SLAB BRACKET. EXISTING APPROACH SLAB BRACKET NOT SHOWN FOR CLARITY.

ALL WORK ON THIS SHEET WILL BE PAID FOR UNDER THE LUMP SUM BID PRICE FOR PARTIAL REMOVAL OF EXISTING STRUCTURE.

PROJECT NO. B-5021
ROBESON COUNTY
BRIDGE: 100

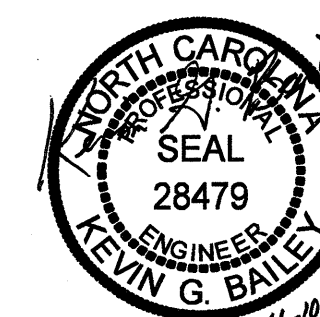

SHEET 1 OF 4

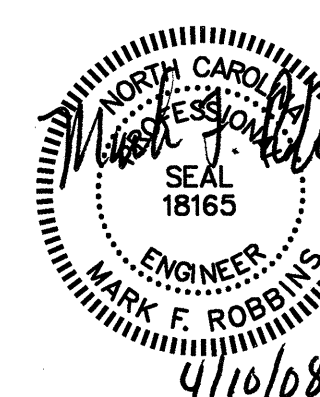

STATE OF NORTH CAROLINA
DEPARTMENT OF TRANSPORTATION
RALEIGH
SUBSTRUCTURE
END BENT
CONCRETE REMOVAL

REVISIONS						SHEET NO.
NO.	BY:	DATE:	NO.	BY:	DATE:	TOTAL SHEETS
1			3			5
2			4			62

D-1809.25

NOT TO SCALE

STV/Ralph Whitehead Associates, Inc.
1000 West Morehead St., Ste. 200
Charlotte, NC 28208

N:\PROJ\2513448\B5021\Bridg\100\Illustration\Finals\Substructure End Bent.Ldgn 4/10/2008 4:47:26 PM timothy.townsend

DRAWN BY : KGB DATE : 1-08
CHECKED BY : PEK DATE : 2-08

NOTES

THE #6D1 & #4K2 BARS SHALL BE SECURED IN EXISTING CONCRETE WITH EPOXY ADHESIVE. FOR ADHESIVELY ANCHORED ANCHOR BOLTS AND DOWELS SEE SPECIAL PROVISION.

THE VERTICAL LEG LENGTH OF THE #6D1 & #4K2 BARS AND #4V2 BARS IS BASED ON A 9" EMBEDMENT INTO EXISTING CONCRETE AND MAY BE ADJUSTED BASED ON THE MINIMUM EMBEDMENT SPECIFIED BY THE MANUFACTURER OF THE EPOXY ADHESIVE BONDING SYSTEM.

THE AREAS OF THE CURTAIN WALL AROUND ANCHOR BOLTS AND BEARING ASSEMBLIES PREVIOUSLY REMOVED SHALL BE RECAST TO PRODUCE SMOOTH, STRAIGHT FINISHED SURFACES USING CLASS AA CONCRETE.

FOR CLEANING AND PAINTING EXISTING BEARING PLATES' SEE SPECIAL PROVISION.

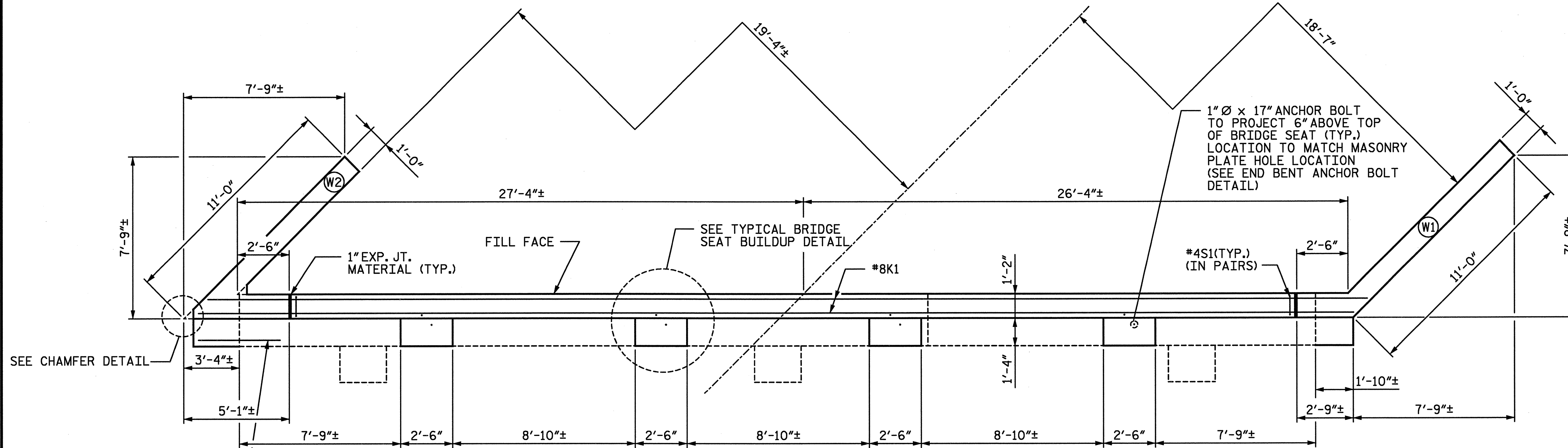

PLAN OF CAP MODIFICATION

END BENT 2 SHOWN, END BENT 1 SIMILAR

NOTE: DIMENSIONS ARE BASED ON BEST AVAILABLE INFORMATION. VERIFY DIMENSIONS IN FIELD AND ADJUST AS NECESSARY SUCH THAT THE 2'-6" BRIDGE SEAT BUILDUP IS CENTERED ABOUT ANCHOR BOLTS.

CONTRACTOR SHALL VERIFY ANCOR BOLT DIAMETER AND ADJUST AS NECESSARY TO MATCH EXISTING ANCHOR BOLT DIAMETER.

ADHESIVELY ANCHOR 6-#6D2 INTO END OF EXISTING CAP FOR CAP EXTENSION. D2 BARS ARE TO BE EQUALLY SPACED AT END OF EXISTING CAP WITH 6" CLEAR FROM EDGES OF CAP. TYPICAL EACH END OF CAP. EMBEDMENT PER MANUFACTURER'S RECOMMENDATIONS

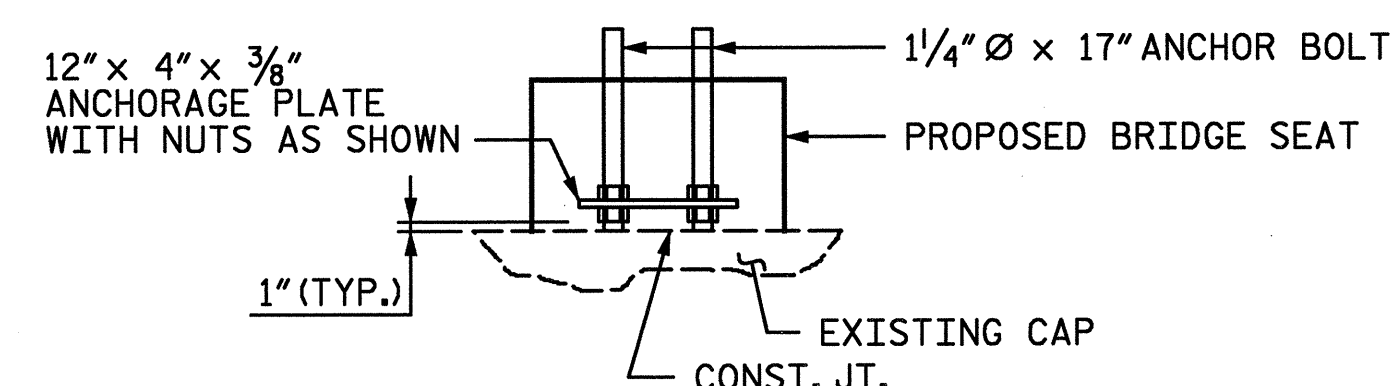

END BENT ANCHOR BOLT DETAIL

(TYPICAL AT EACH BEARING LOCATION)

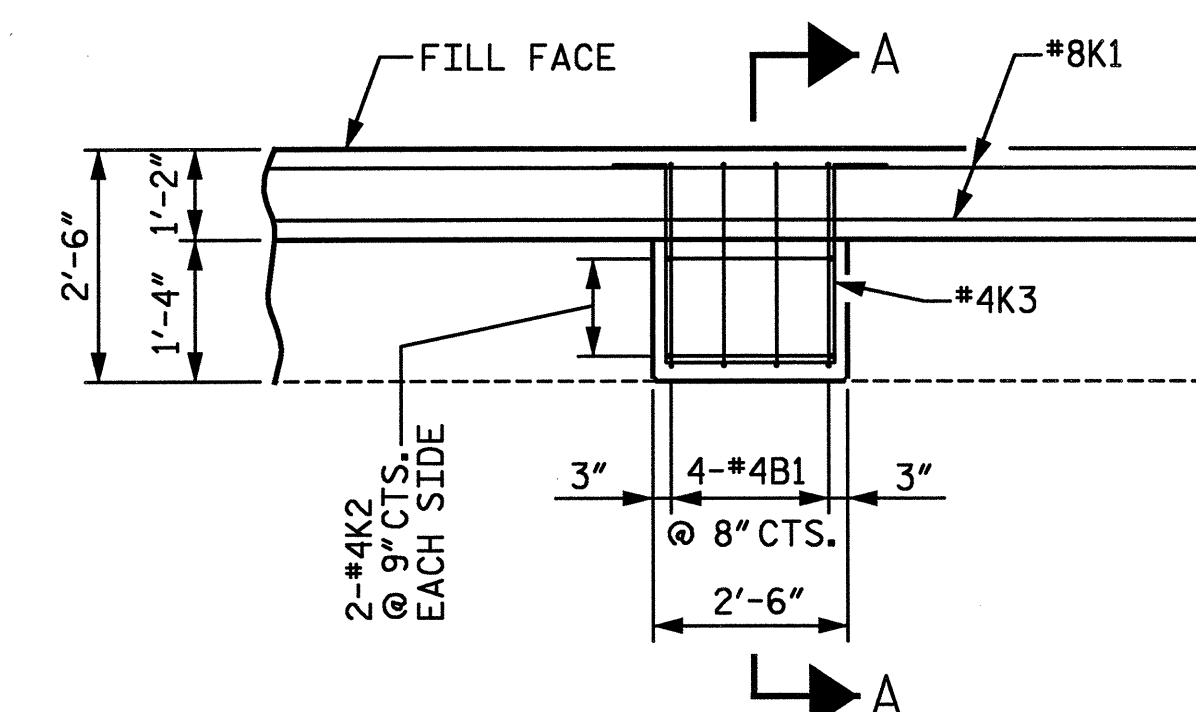

TYPICAL BRIDGE SEAT BUILDUP

#4S1 STIRRUPS & #6D1 DOWELS NOT SHOWN FOR CLARITY

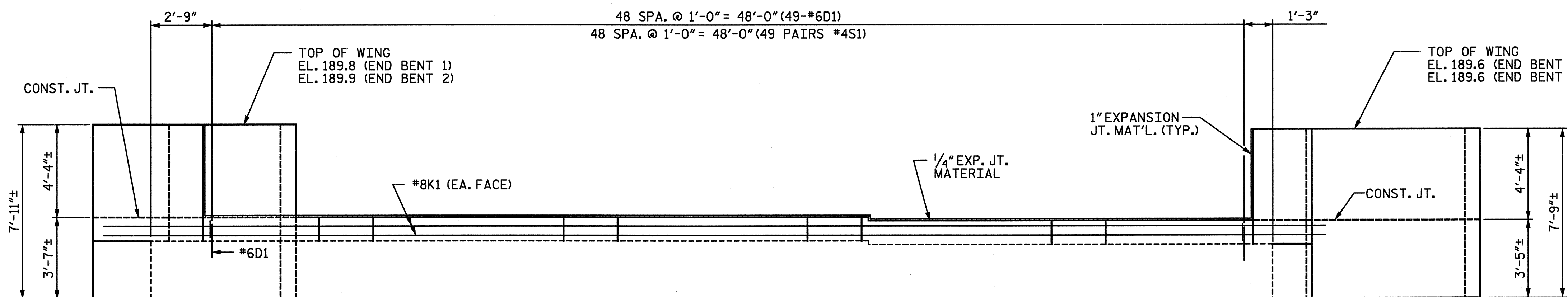

ELEVATION OF CAP MODIFICATION

END BENT 2 SHOWN, END BENT 1 SIMILAR

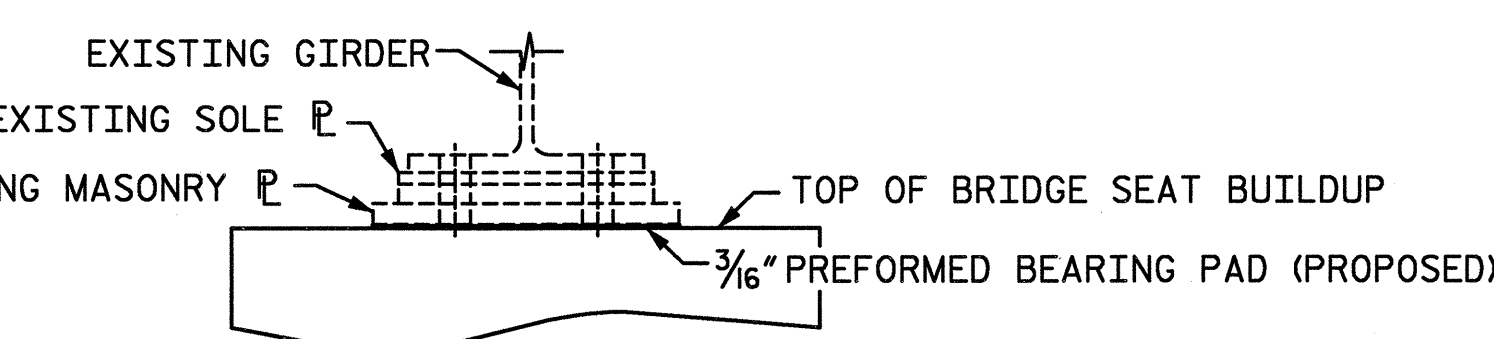

TYPICAL BEARING ASSEMBLY

END BENTS 1 & 2

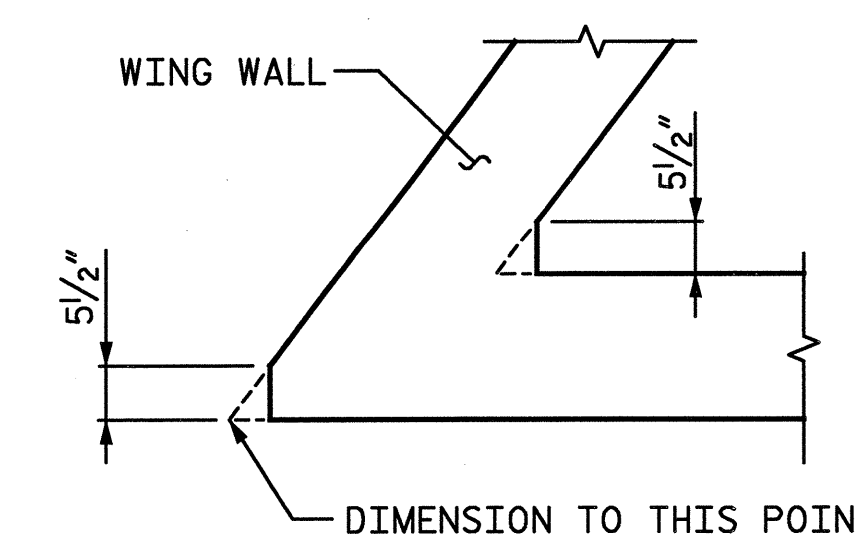

CHAMFER DETAIL

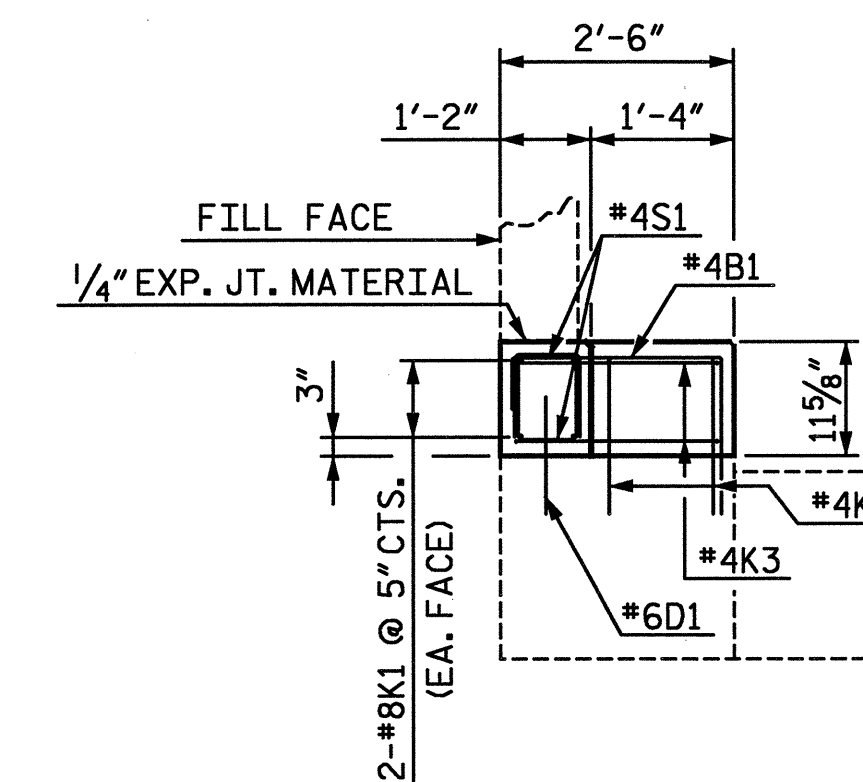

SECTION A-A

PROJECT NO. B-5021
 ROBESON COUNTY
 BRIDGE: 100

SHEET 2 OF 4

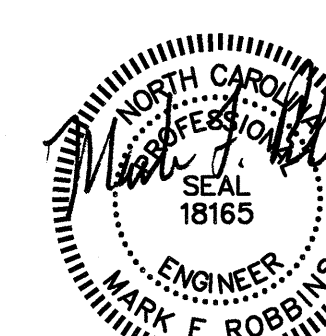
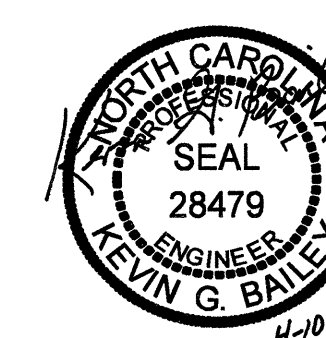

STATE OF NORTH CAROLINA
 DEPARTMENT OF TRANSPORTATION
 RALEIGH
 SUBSTRUCTURE
 END BENT
 CAP MODIFICATIONS

REVISIONS						SHEET NO.
NO.	BY:	DATE:	NO.	BY:	DATE:	S-26
1			3			TOTAL SHEETS
2			4			62

D-1809.26

NOT TO SCALE

STV/Ralph Whitehead Associates, Inc.
 1000 West Morehead St., Ste. 200
 Charlotte, NC 28208

N:\PROJ\2513448\B5021\Bridge 100\Station\Finals\Substructure End Bent-2.dgn

11:03:54 AM

timothy.townsend 4/10/2008

DRAWN BY: KGB DATE: 1-08
 CHECKED BY: PEK DATE: 3-08

NOTES

THE CONTRACTOR SHALL PROVIDE FOR INSTALLATION OF THE 4" DRAIN PIPE THROUGH THE WING WALL AS REQUIRED FOR REINFORCED BRIDGE APPROACH FILL. SEE BRIDGE APPROACH SLAB FOR FLEXIBLE PAVEMENT SHEET. REINFORCING STEEL IN THE WING WALL MAY BE SHIFTED SLIGHTLY AS NECESSARY TO CLEAR DRAIN PIPE.

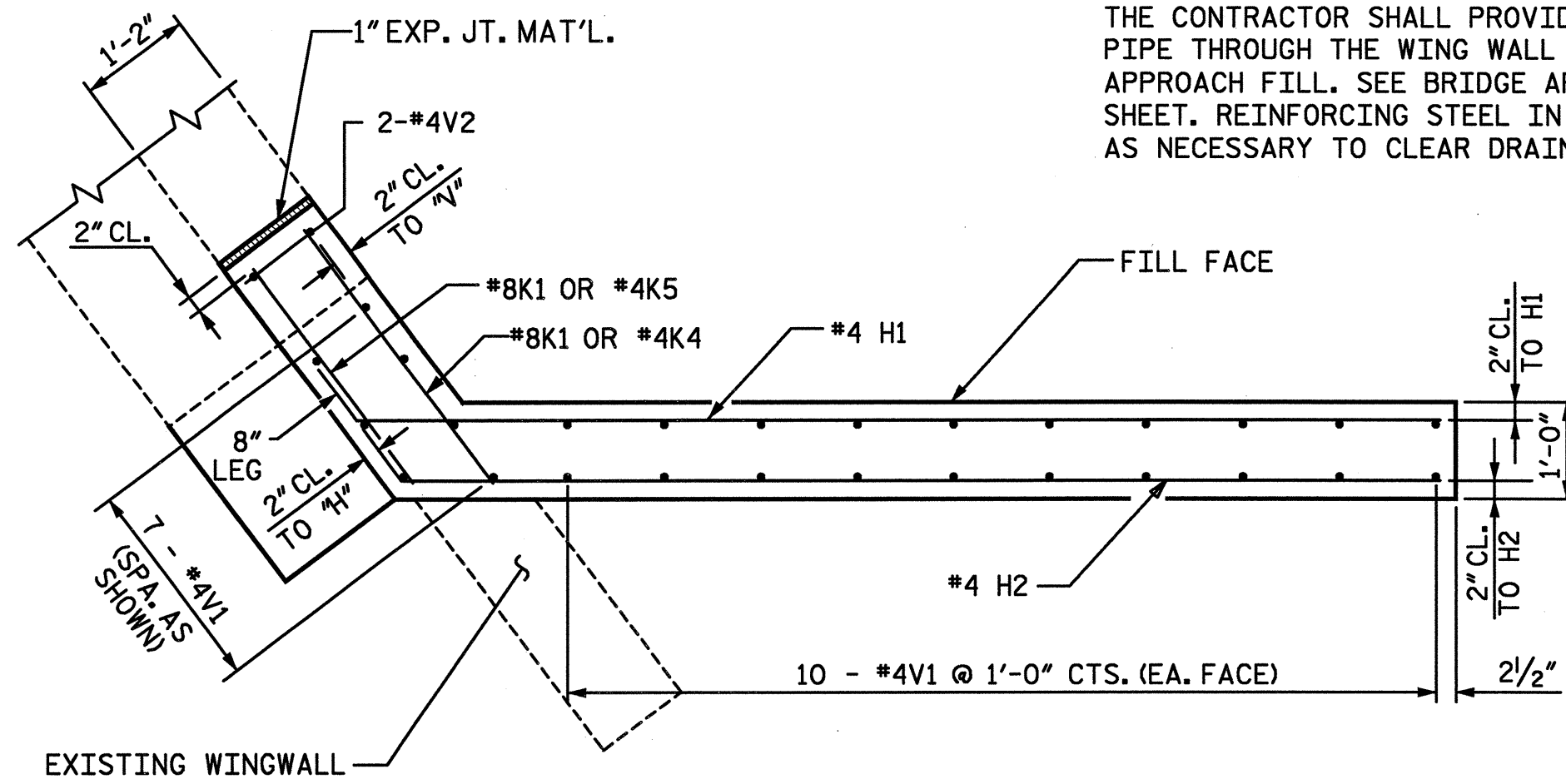

PLAN OF RIGHT WING - W1

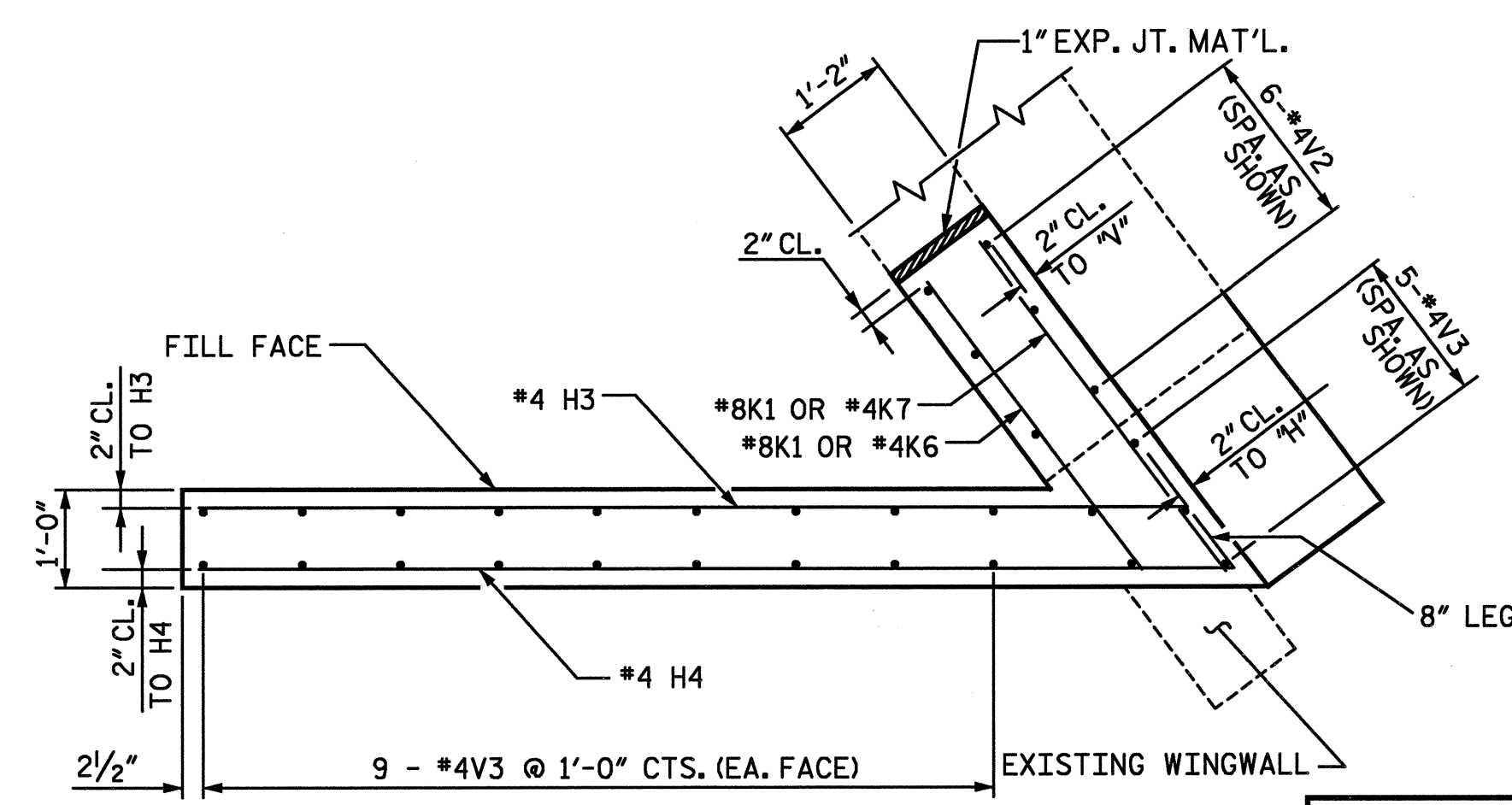

PLAN OF LEFT WING - W2

NOTE: #4V2 BARS SHALL BE EPOXIED INTO EXISTING BENT CAP.

CLASS AA CONCRETE BREAKDOWN FOR 1 END BENT		
POUR 1 CAP AND LOWER WINGWALLS	C. Y.	5.8
POUR 2 BRIDGE SEATS AND UPPER WINGWALLS	C. Y.	4.6
POUR 3 APPROACH SLAB BRACKETS	C. Y.	1.2
CLASS AA CONCRETE	C. Y.	11.6

BILL OF MATERIAL FOR ONE END BENT (2 REQ'D)					
BAR	NO.	SIZE	TYPE	LENGTH	WEIGHT
B1	16	#4	1	3'-8"	39
D1	49	#6	STR	1'-6"	110
D2	12	#6	7	4'-9"	74
H1	9	#4	2	12'-1"	73
H2	9	#4	2	11'-5"	69
H3	9	#4	3	10'-5"	63
H4	9	#4	3	11'-1"	67
J1	43	#5	6	2'-6"	112
J2	43	#5	7	1'-10"	82
K1	4	#8	STR	55'-9"	595
K2	16	#4	1	3'-6"	37
K3	8	#4	5	7'-7"	41
K4	4	#4	STR	3'-3"	9
K5	4	#4	STR	2'-7"	7
K6	4	#4	STR	3'-9"	10
K7	4	#4	STR	4'-5"	12
K8	2	#5	STR	42'-2"	88
S1	98	#4	4	2'-0"	131
V1	26	#4	STR	7'-3"	126
V2	8	#4	STR	5'-9"	31
V3	23	#4	STR	7'-5"	114
REINFORCING STEEL					LBS. 1,890

BAR TYPES

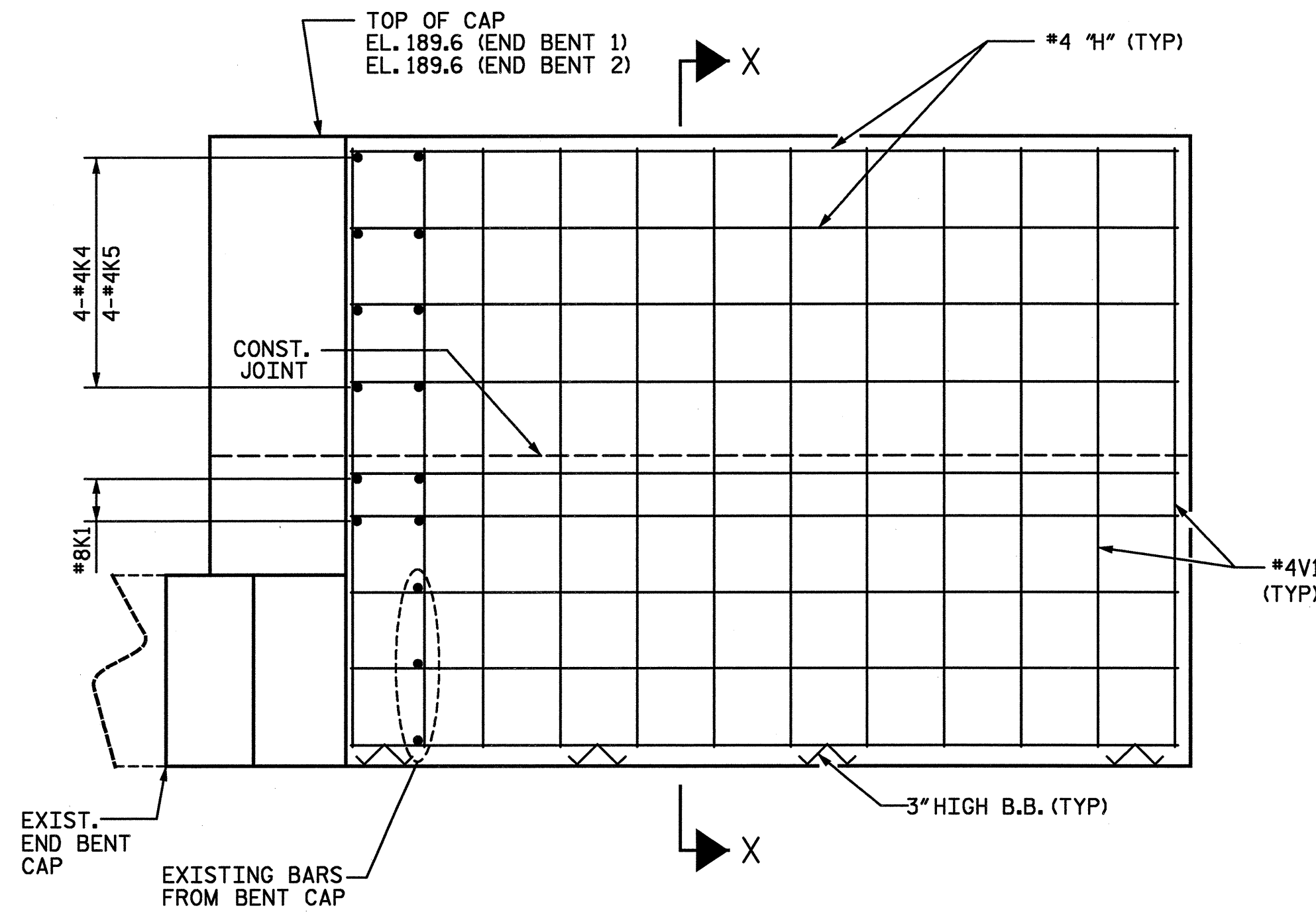

ELEVATION OF RIGHT WING

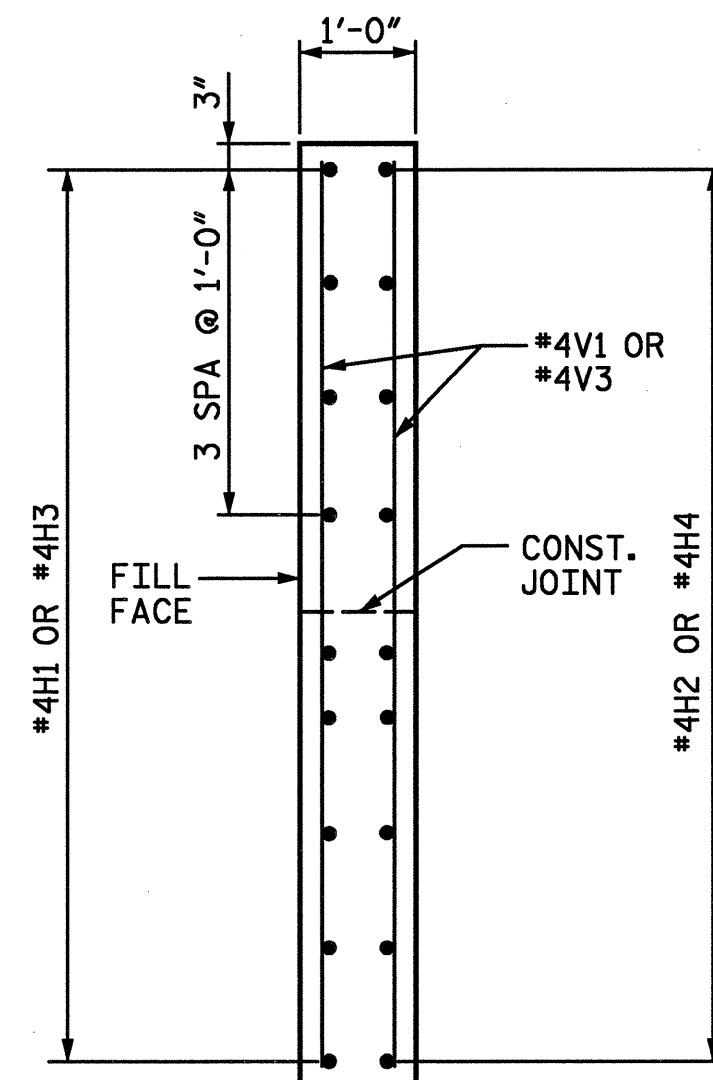

SECTION X-X

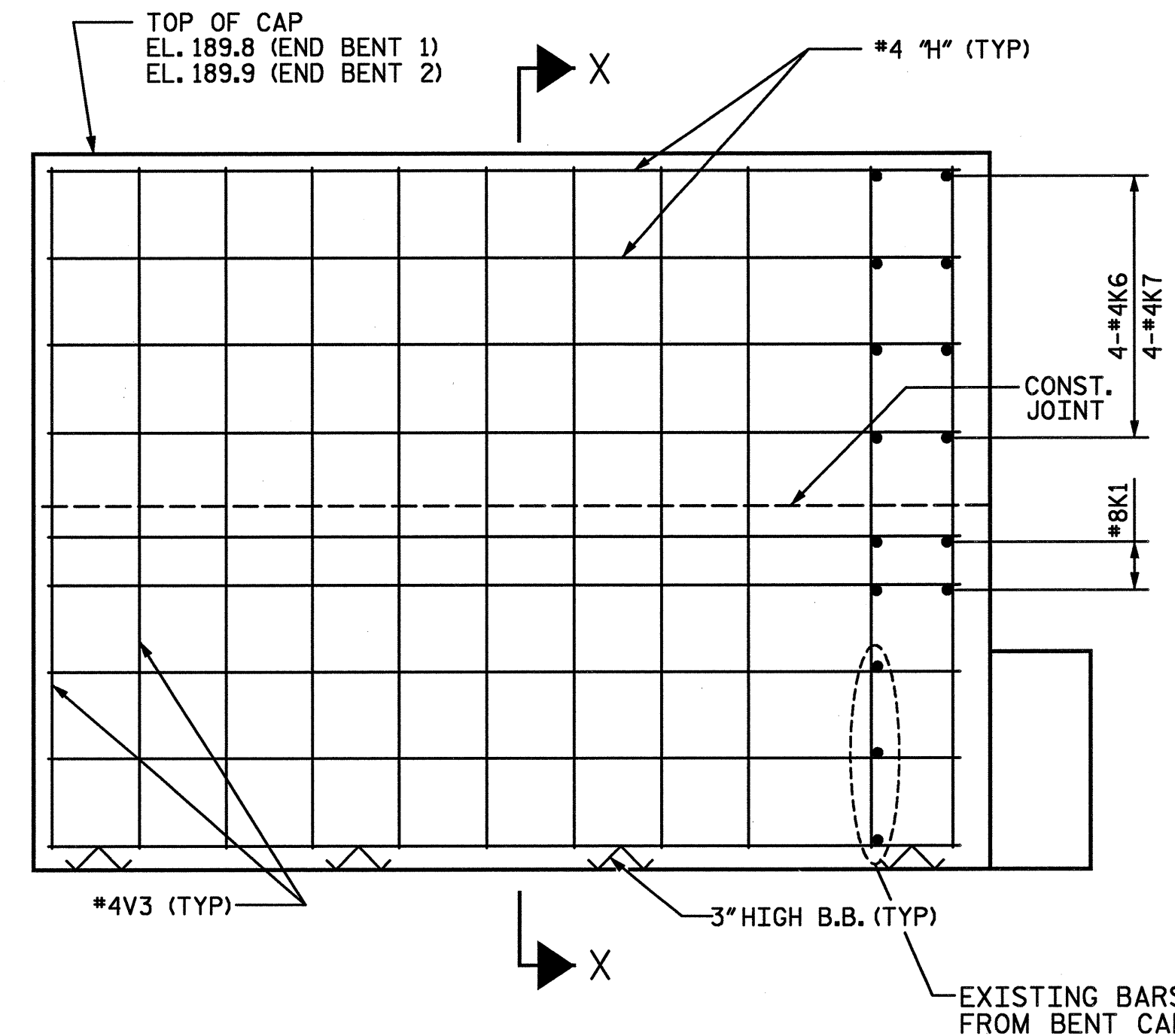

ELEVATION OF LEFT WING

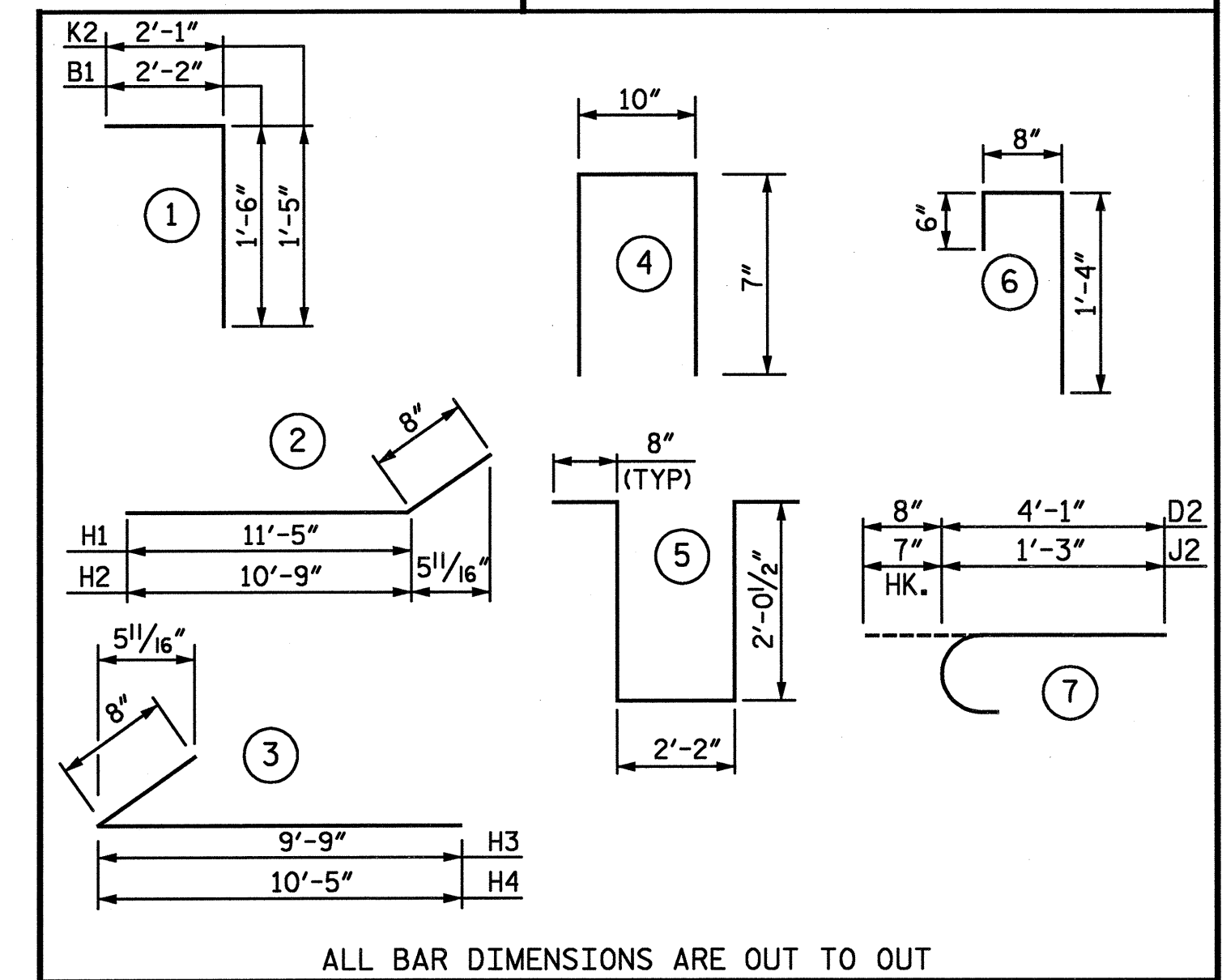

REINFORCING FOR TURNED BACK WINGS

END BENT 2 SHOWN, END BENT 1 SIMILAR

PROJECT NO. B-5021
 ROBESON COUNTY
 BRIDGE: 100

SHEET 3 OF 4

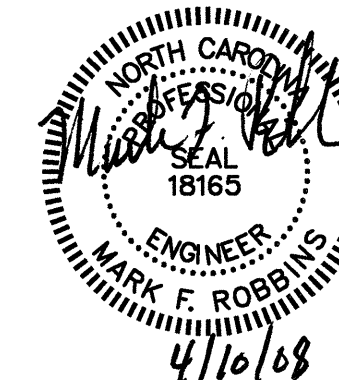
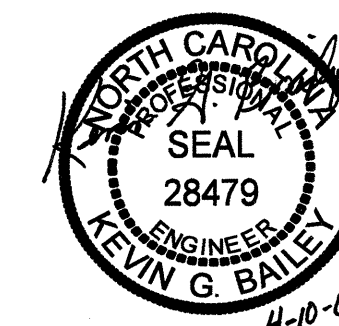

STATE OF NORTH CAROLINA
 DEPARTMENT OF TRANSPORTATION
 RALEIGH
 SUBSTRUCTURE
 END BENT
 WINGWALL MODIFICATIONS

REVISIONS						SHEET NO.
NO.	BY:	DATE:	NO.	BY:	DATE:	
1			3			5-27
2			4			TOTAL SHEETS 62

D-1809.27

NOT TO SCALE

STV/Ralph Whitehead Associates, Inc.
 1000 West Morehead St., Ste. 200
 Charlotte, NC 28208

N:\PROJ\2513448\B5021\Bridge 100\Station\Finals\Substructure End Bent_3.dgn

ih03152AWM

timothy.townsend 4/10/2008

DRAWN BY: KGB DATE: 1-08
 CHECKED BY: PEK DATE: 3-08

N:\PROJ\2513448\B502\Bridge 100\Station\Finals\Substructure End Bent_4.dgn

11:03:50 AM

timothy.townsend 4/10/2008

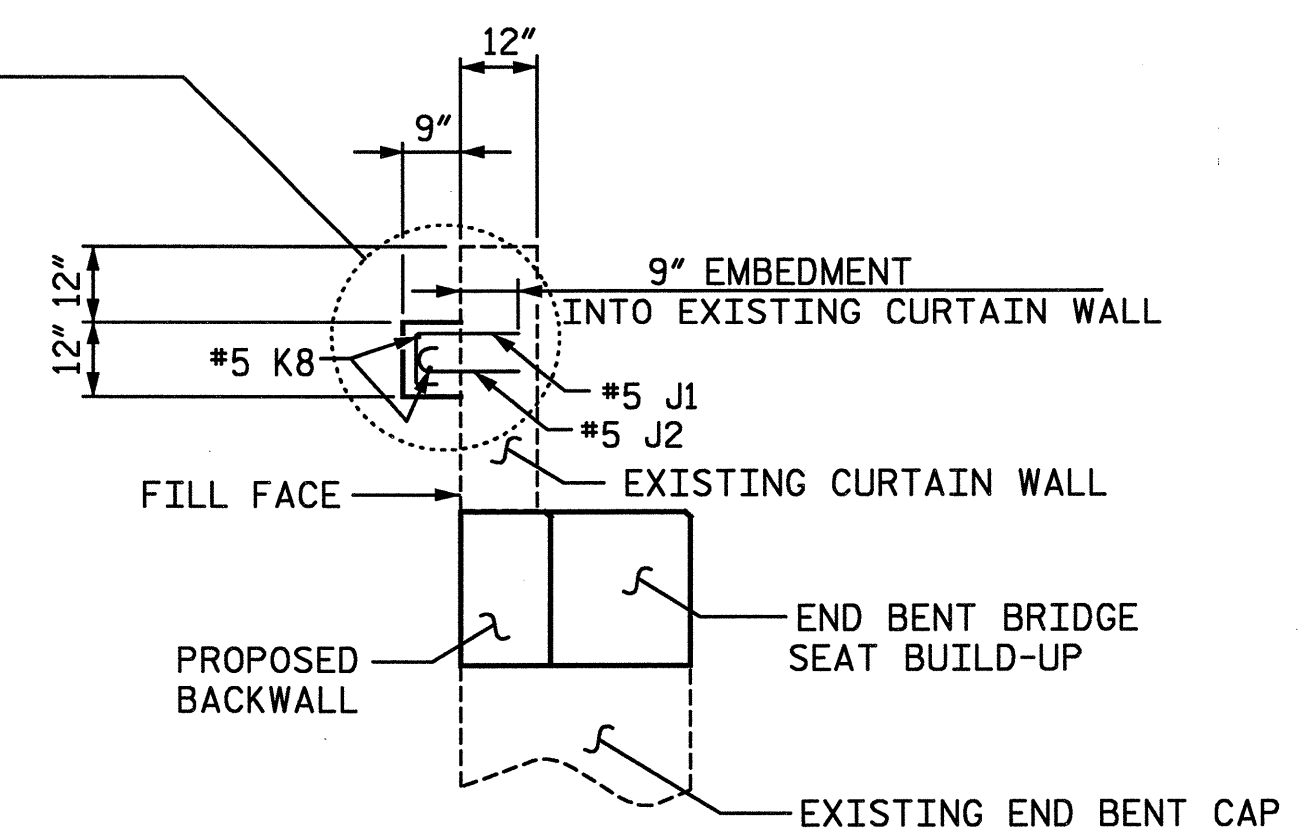
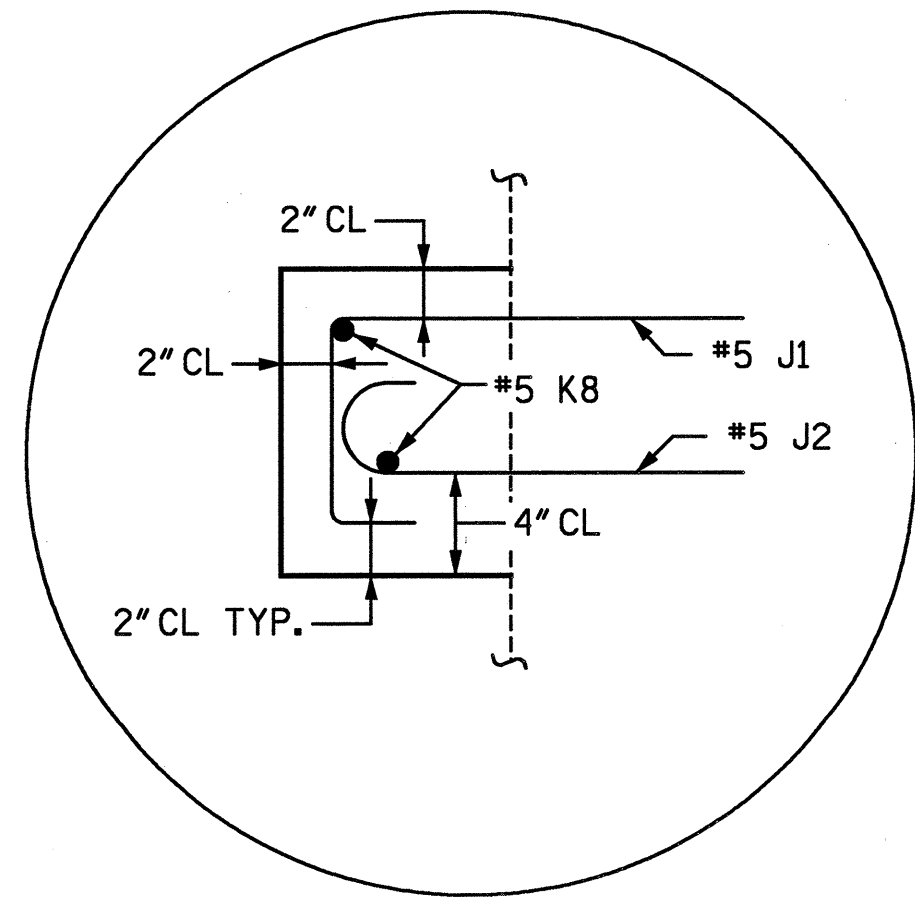
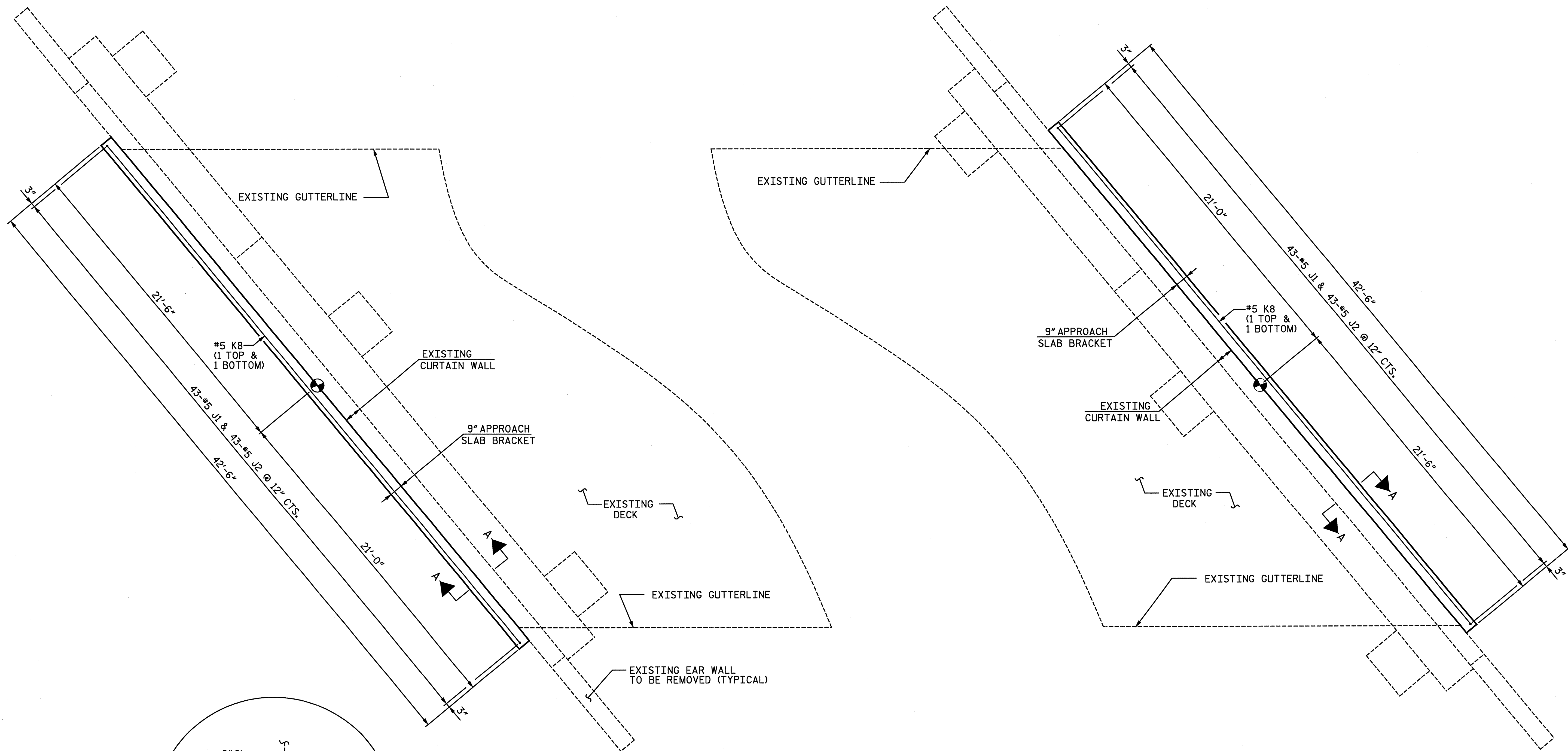

PLACEMENT OF APPROACH SLAB BRACKETS

(PROPOSED WING WALLS OMITTED FOR CLARITY)

NOTES

THE #5J1 AND #5J2 BARS SHALL BE SECURED INTO THE EXISTING CONCRETE WITH EPOXY ADHESIVE.

THE LEG LENGTH OF THE #5J1 AND #5J2 BAR IS BASED ON A 9" EMBEDMENT INTO THE EXISTING CONCRETE AND MAY BE ADJUSTED BASED ON THE MINIMUM EMBEDMENT SPECIFIED BY THE MANUFACTURER OF THE EPOXY ADHESIVE BONDING SYSTEM.

INSTALL #5J2 BARS AND THEN INSTALL #5J1 BARS TO ALLOW FOR BAR ROTATION DURING INSTALLATION.

#5J1 AND #5J2 BARS SHALL BE EPOXIED IN EXISTING CURTAIN WALL AS DETAILED. THE COST OF DRILLING IN AND EPOXYING THE #5J1 AND #5J2 BARS SHALL BE CONSIDERED INCIDENTAL AND INCLUDED IN THE COST OF THE REINFORCING STEEL.

FOR ADHESIVELY ANCHORED ANCHOR BOLTS OR DOWELS, SEE SPECIAL PROVISIONS.

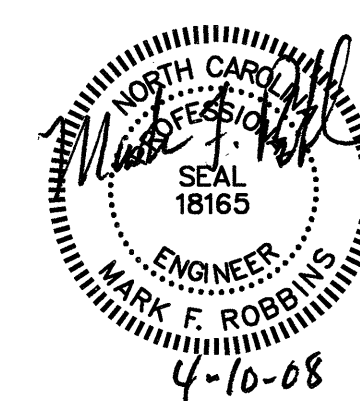
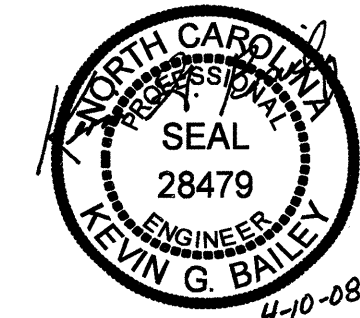

PROJECT NO. **B-5021**
ROBESON COUNTY
 BRIDGE: **100**

SHEET 4 OF 4

STATE OF NORTH CAROLINA
 DEPARTMENT OF TRANSPORTATION
 RALEIGH

**SUBSTRUCTURE
 END BENT
 APPROACH SLAB BRACKETS**

REVISIONS						SHEET NO.
NO.	BY:	DATE:	NO.	BY:	DATE:	S-28
1			3			TOTAL SHEETS
2			4			62

DRAWN BY : **KGB** DATE : **1-08**
 CHECKED BY : **MFR** DATE : **3-08**

NOT TO SCALE
 D-1809.28
STV/Ralph Whitehead Associates, Inc.
 1000 West Morehead St., Ste. 200
 Charlotte, NC 28208

PVI STA. 21+00.00
PVI EL. 188.75
LVC = 420.00
(+)-0.300% (-)-5.0968%

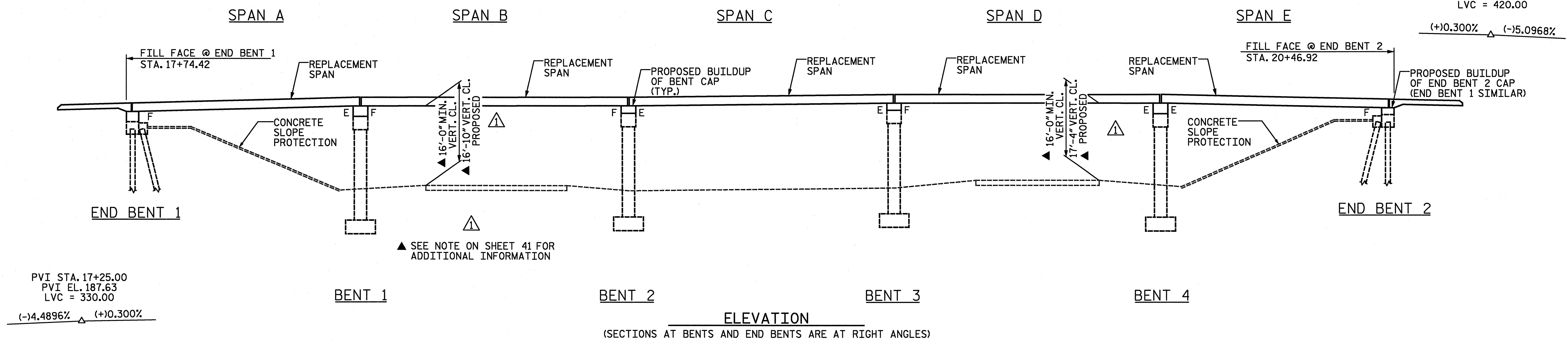

PVI STA. 17+25.00
PVI EL. 187.63
LVC = 330.00
(-)-4.4896% (+)-0.300%

ALL DIMENSIONS IN THESE PLANS ARE BASED ON BEST AVAILABLE INFORMATION. THE CONTRACTOR SHALL VERIFY DIMENSIONS IN FIELD PRIOR TO CONSTRUCTION AND ANY FABRICATION. CONTRACTOR SHALL NOTIFY THE ENGINEER OF ANY DISCREPANCIES SUCH THAT NECESSARY ADJUSTMENTS BE MADE BY THE CONTRACTOR.

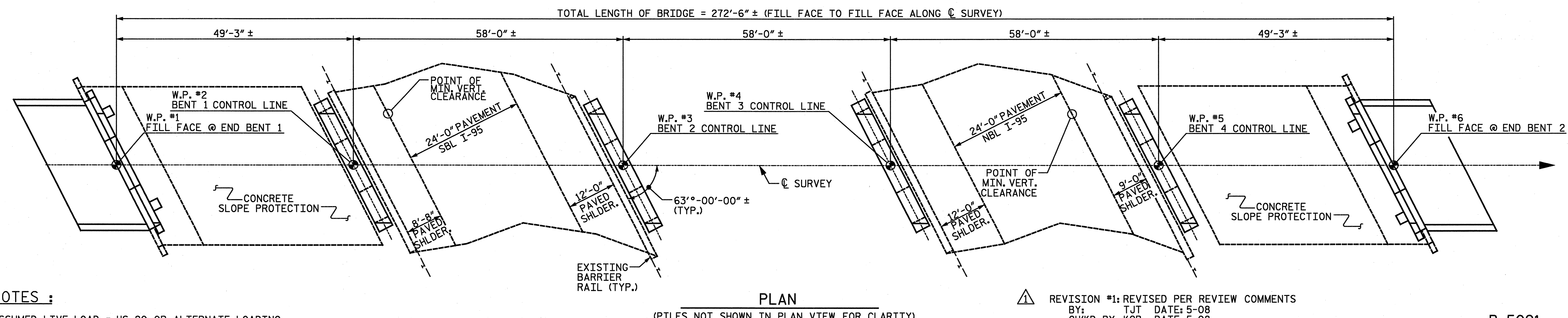

- NOTES :**
- ASSUMED LIVE LOAD = HS 20 OR ALTERNATE LOADING.
 - FOR OTHER DESIGN DATA AND GENERAL NOTES, SEE SHEET SN.
 - CORED SLABS HAVE BEEN DESIGNED BY THE STRENGTH DESIGN METHOD AS SPECIFIED IN AASHTO STANDARD SPECIFICATIONS.
 - ALL SPANS ON EXISTING STRUCTURE CONSISTING OF PRESTRESSED CONCRETE GIRDERS, 24'-0" CLEAR ROADWAY WIDTH, REINFORCED CONCRETE DECK SHALL BE REMOVED. CURTAIN WALL AT END BENTS SHALL BE REMOVED. FOR PARTIAL REMOVAL OF EXISTING STRUCTURE, SEE SPECIAL PROVISIONS.
 - FOR PRESTRESSED CONCRETE MEMBERS, SEE SPECIAL PROVISIONS.
 - FOR SUBMITTAL OF WORKING DRAWINGS, SEE SPECIAL PROVISIONS.
 - FOR FALSEWORK AND FORMWORK, SEE SPECIAL PROVISIONS.
 - FOR CRANE SAFETY, SEE SPECIAL PROVISIONS.
 - FOR MAINTENANCE AND PROTECTION OF TRAFFIC BENEATH PROPOSED STRUCTURE, SEE SPECIAL PROVISIONS.

REVISION #1: REVISED PER REVIEW COMMENTS
BY: TJT DATE: 5-08
CH'KD BY: KGB DATE: 5-08

TOTAL BILL OF MATERIAL									
	PARTIAL REMOVAL OF EXISTING STRUCTURE	CLASS AA CONCRETE	REINFORCING STEEL	CONCRETE BARRIER RAIL	ELASTOMERIC BEARINGS	3'-0" X 1'-9" PRESTRESSED CONCRETE CORED SLABS	EPOXY RESIN INJECTION	EPOXY MORTAR REPAIRS	BRIDGE APPROACH SLABS
	LUMP SUM	CU. YDS.	LBS.	LIN. FT.	LUMP SUM	LIN. FT.	LIN. FT.	LBS.	LUMP SUM
SUPERSTRUCTURE	LUMP SUM			539.0	LUMP SUM	2,425.1			LUMP SUM
END BENT 1		8.8	1,466						
BENT 1		17.4	2,108				5.0	3.0	
BENT 2		17.4	2,108					2.0	
BENT 3		17.4	2,108				50.0		
BENT 4		17.4	2,108				20.0		
END BENT 2		8.8	1,466						
TOTAL	LUMP SUM	87.2	11,364	539.0	LUMP SUM	2,425.1	75.0	5.0	

PROJECT NO. B-5021
ROBESON COUNTY

BRIDGE: 162
MODIFICATION OF BRIDGE NO. 162

STATE OF NORTH CAROLINA
DEPARTMENT OF TRANSPORTATION
RALEIGH

**GENERAL DRAWING
BRIDGE OVER I-95
ON SR 1726**

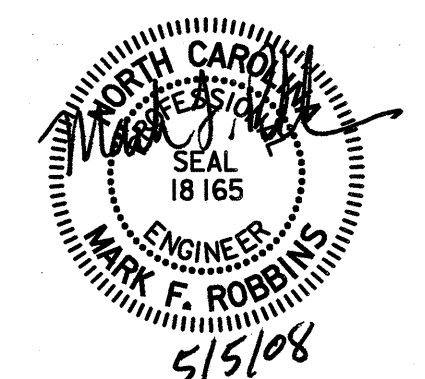
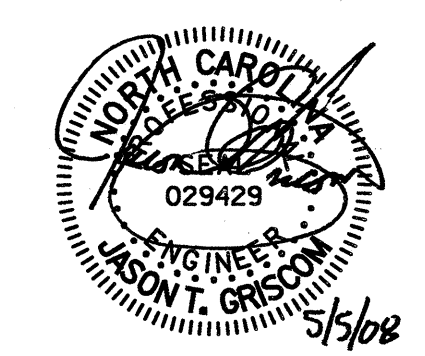

REVISIONS						SHEET NO.
NO.	BY:	DATE:	NO.	BY:	DATE:	5-30
1	STV	5-08	3			TOTAL SHEETS
2			4			62

DRAWN BY: JTG DATE: 3-08
CHECKED BY: TBQ DATE: 3-08

D-1809.30
STV / Ralph Whitehead Associates, Inc.
1000 West Morehead St., Ste. 200
Charlotte, NC 28208

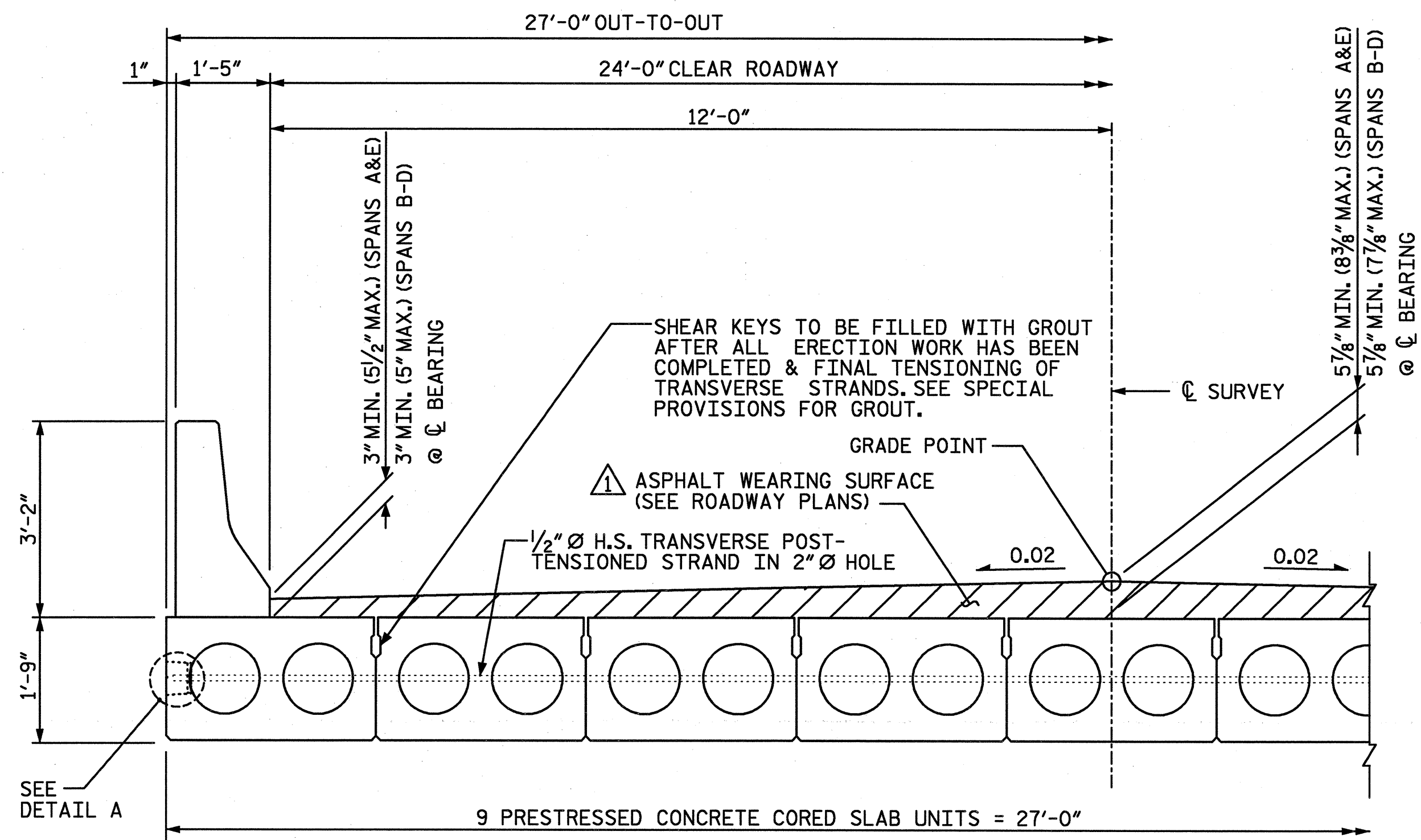

TYPICAL HALF SECTION
(BRIDGE SYMMETRIC ABOUT C SURVEY)

NOTE: ASPHALT WEARING SURFACE IS INCLUDED IN THE QUANTITIES ON THE ROADWAY PLANS.

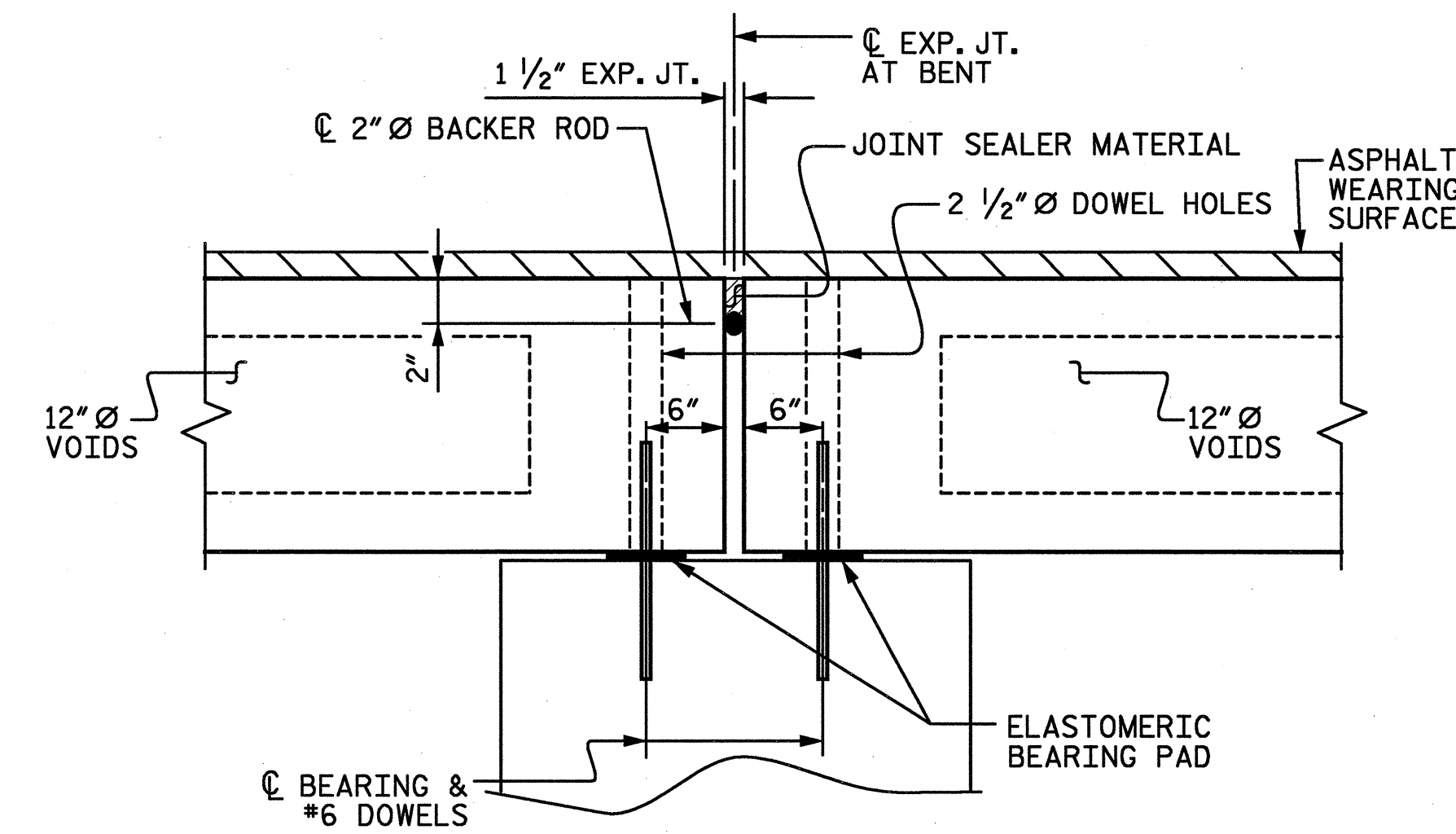

SECTION AT INTERIOR BENTS

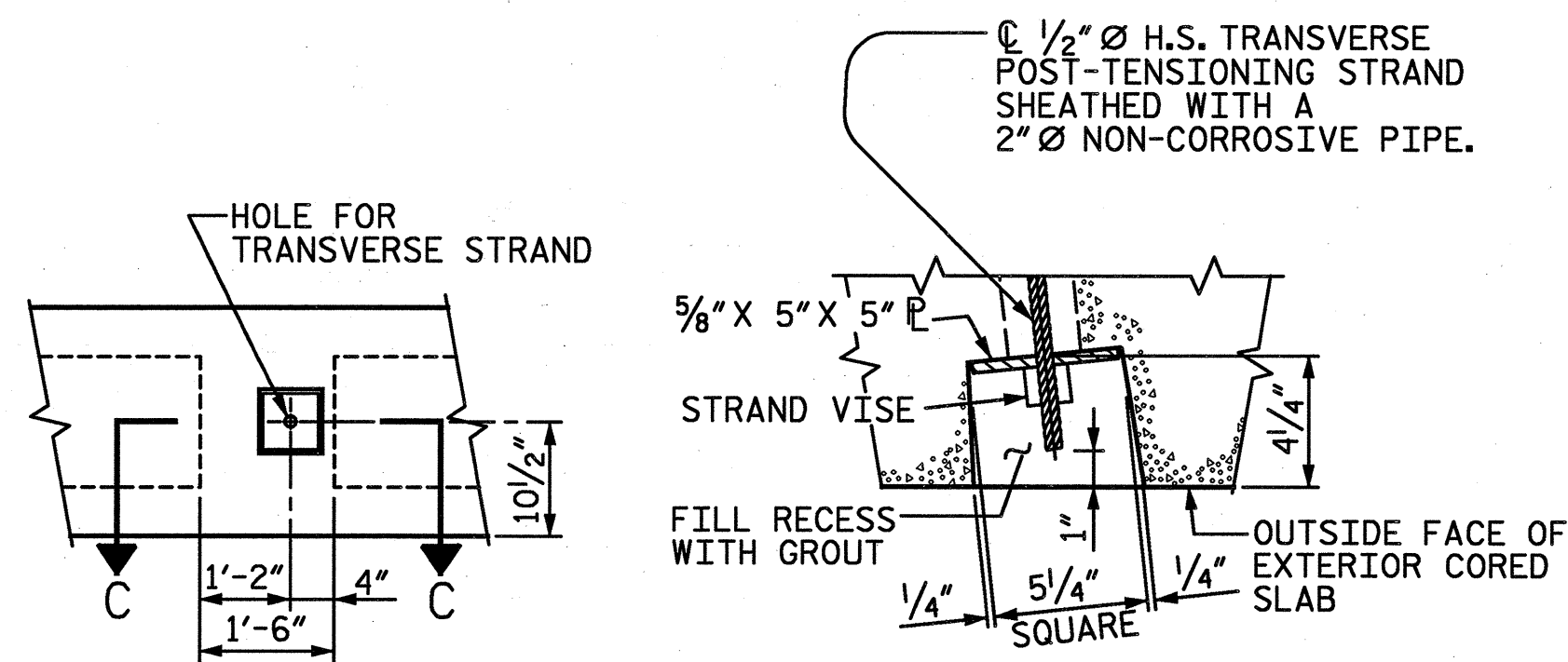

ELEVATION VIEW

SECTION C-C

DETAIL A

GROUTED RECESS AT END OF POST-TENSIONED STRAND CORED SLABS

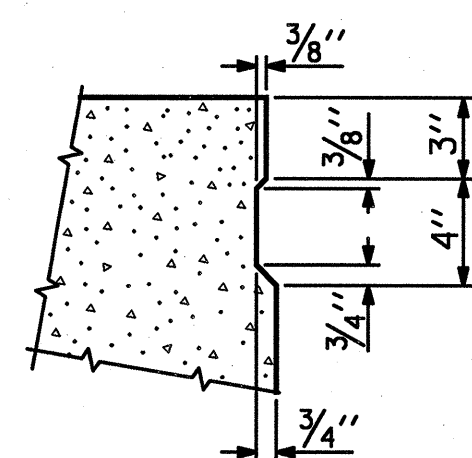

SHEAR KEY DETAIL

NOTE: OMIT SHEAR KEY ON OUTSIDE FACE OF EXTERIOR CORED SLAB

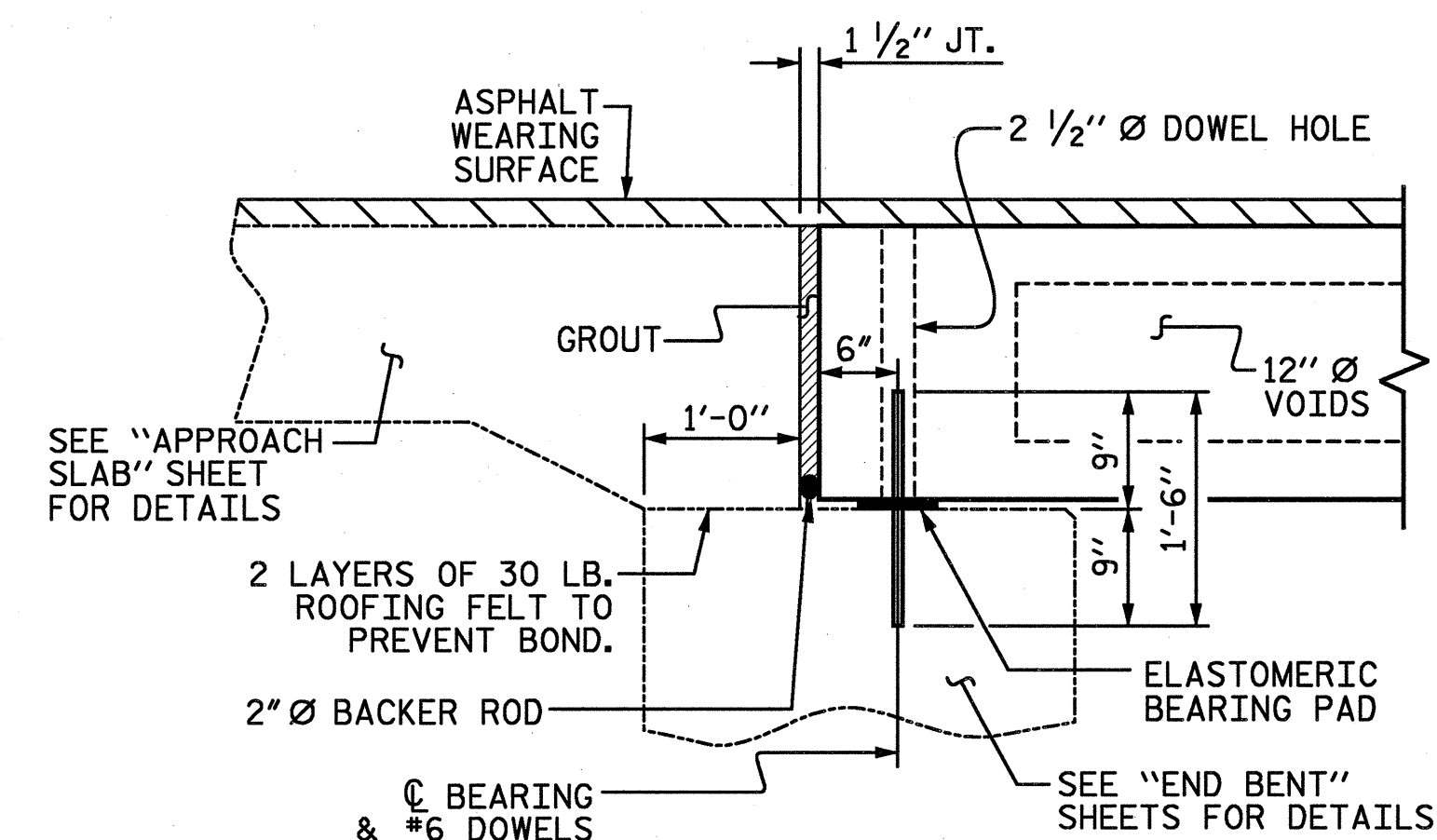

SECTION AT END BENT

PROJECT NO. B-5021
ROBESON COUNTY
BRIDGE: 162

SHEET 1 OF 7

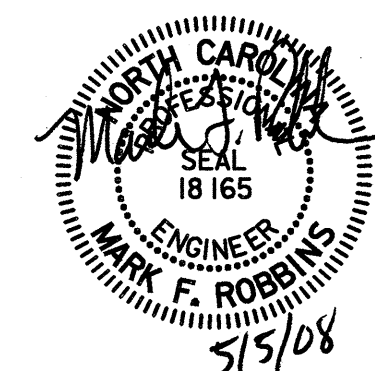
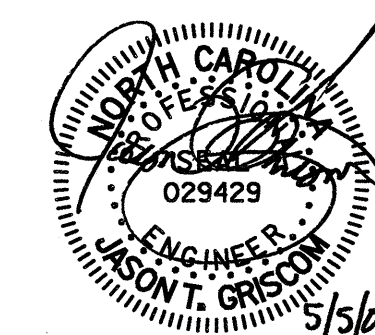

STATE OF NORTH CAROLINA
DEPARTMENT OF TRANSPORTATION
RALEIGH

TYPICAL SECTION AND DETAILS

REVISION #1: REVISED PER REVIEW COMMENTS
BY: TJT DATE: 5-08
CHK'D BY: KGB DATE: 5-08

D-1809.31

STV / Ralph Whitehead Associates, Inc.
1000 West Morehead St., Ste. 200
Charlotte, NC 28208

REVISIONS						SHEET NO.
NO.	BY:	DATE:	NO.	BY:	DATE:	5-31
1	STV	5-08	3			TOTAL SHEETS
2			4			62

DRAWN BY: LGH DATE: 2-08
CHECKED BY: TBQ DATE: 3-08

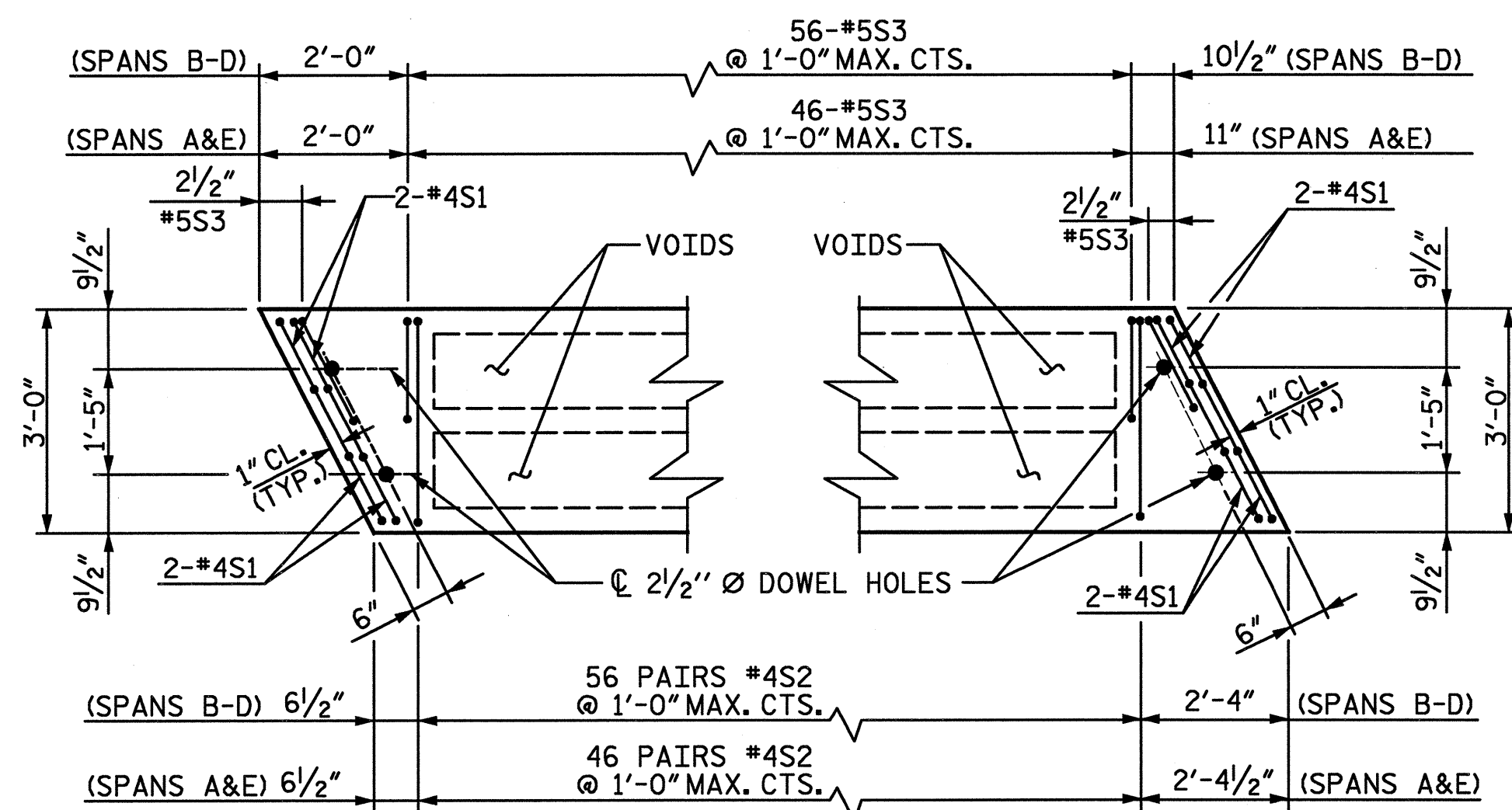

**PART PLAN
EXTERIOR SLAB SECTION**

(LEFT SIDE SHOWN, RIGHT SIDE SIMILAR BY SYMMETRY)

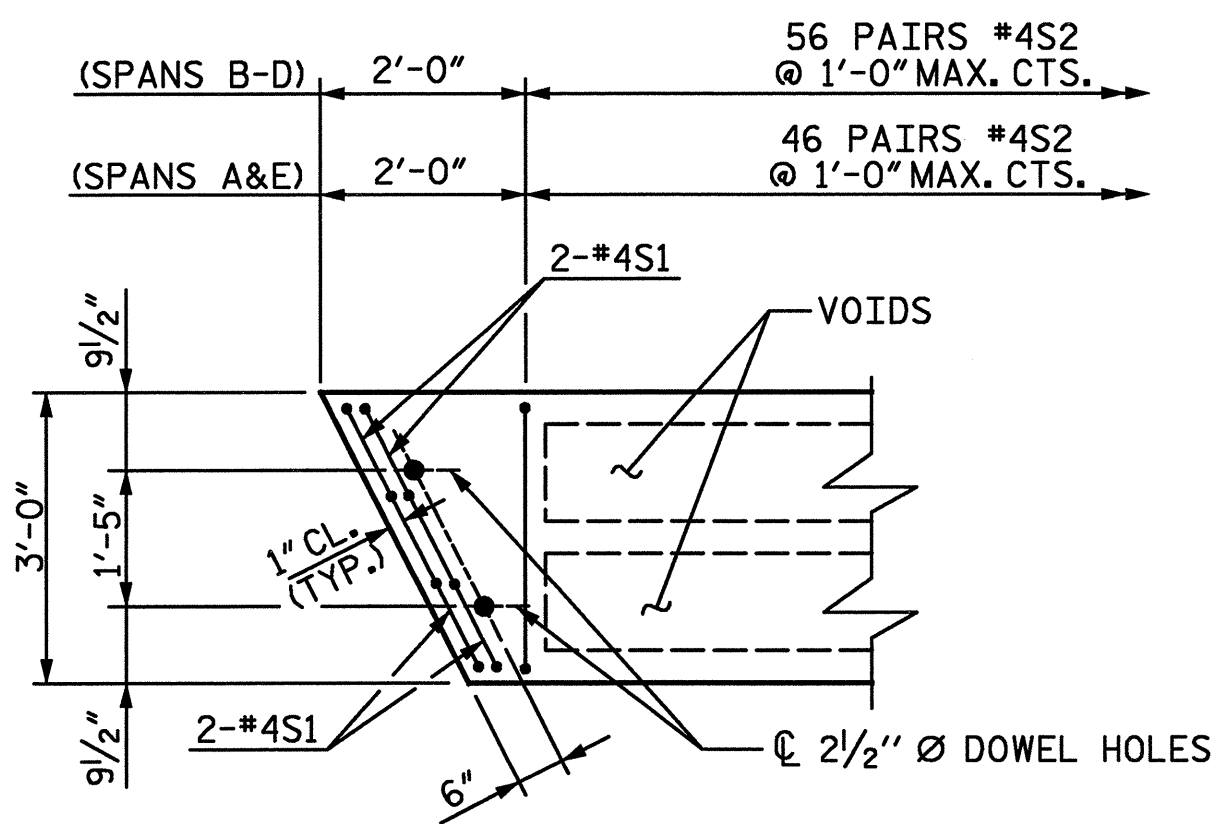

**PART PLAN
INTERIOR SLAB SECTION**

(FAR END SHOWN, NEAR END SIMILAR BY SYMMETRY)

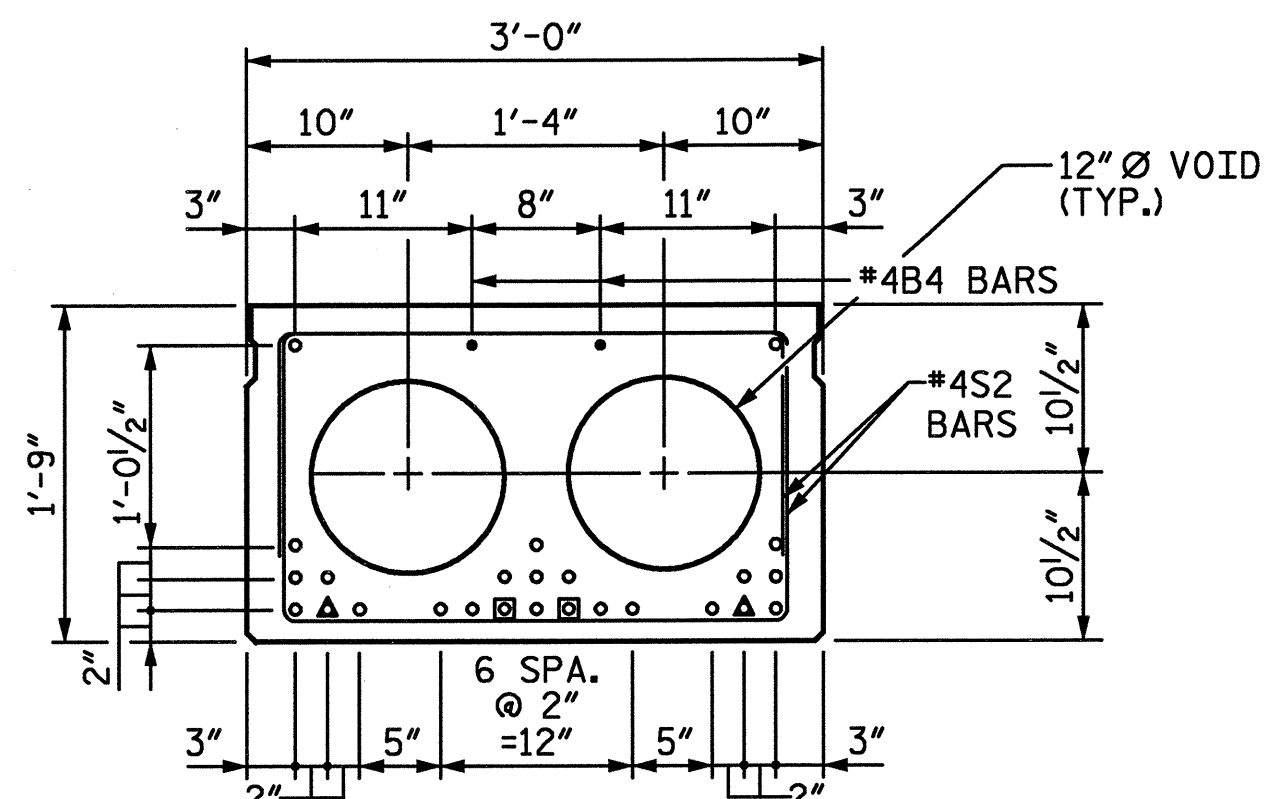

**SPANS B-D
INTERIOR SLAB SECTION**

(25 TOTAL STRANDS REQUIRED)

- DENOTES 1/2" Ø L.R. STRANDS
- △ DENOTES SHEATHED STRAND. BOND SHALL BE BROKEN ON THESE STRANDS FOR A DISTANCE OF 4'-0" FROM END OF SLAB.
- ☒ DENOTES SHEATHED STRAND. BOND SHALL BE BROKEN ON THESE STRANDS FOR A DISTANCE OF 6'-0" FROM END OF SLAB.

SEE STANDARD SPECIFICATIONS ARTICLE 1078-7.

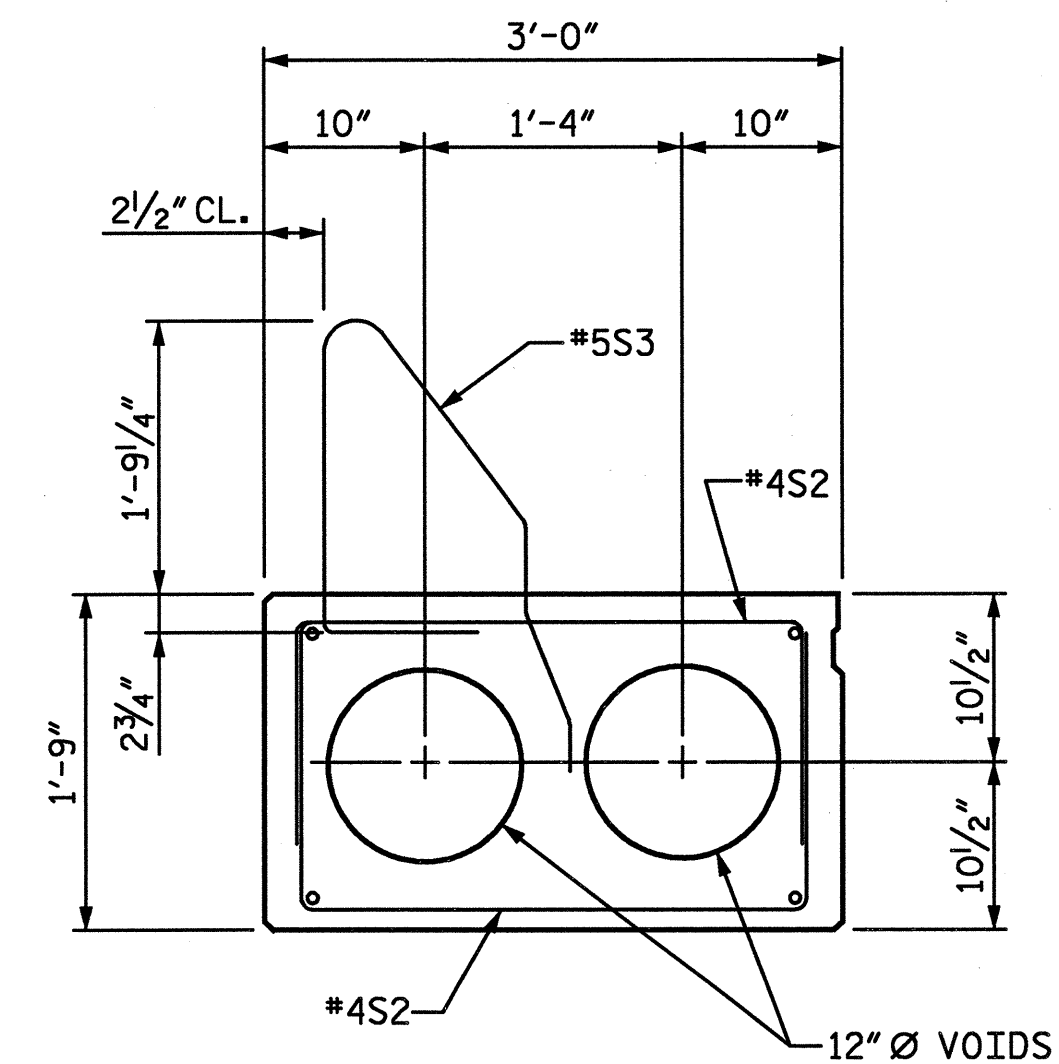

**SPANS B-D
EXTERIOR SLAB SECTION**

(FOR PRESTRESSED STRAND AND #4B4 BAR LAYOUT, SEE INTERIOR SLAB SECTION)

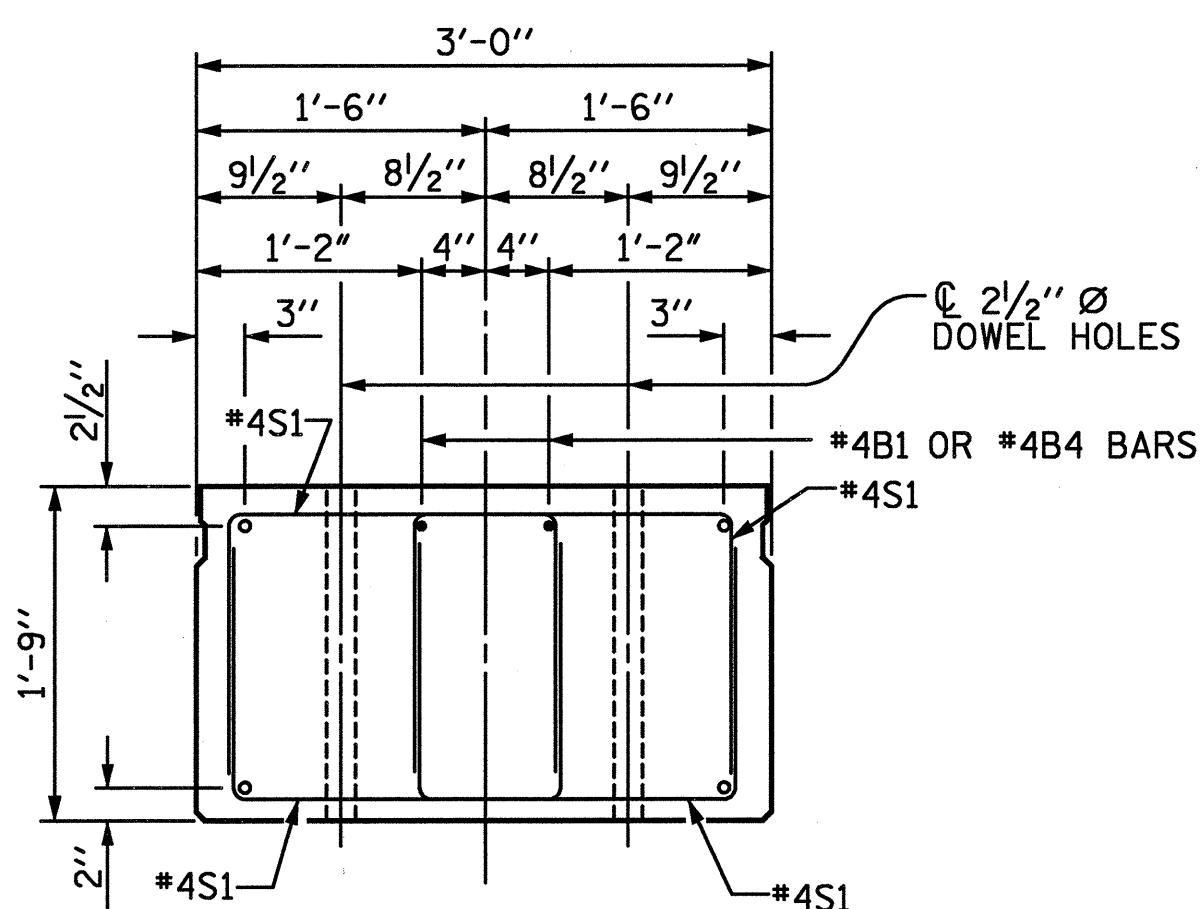

SLAB END ELEVATION

SHOWING PLACEMENT OF DOUBLE STIRRUPS AND LOCATION OF DOWEL HOLES.

INTERIOR SLAB SECTION SHOWN, EXTERIOR SLAB SECTION SIMILAR EXCEPT SHEAR KEY LOCATION.

STRAND LAYOUT NOT SHOWN.

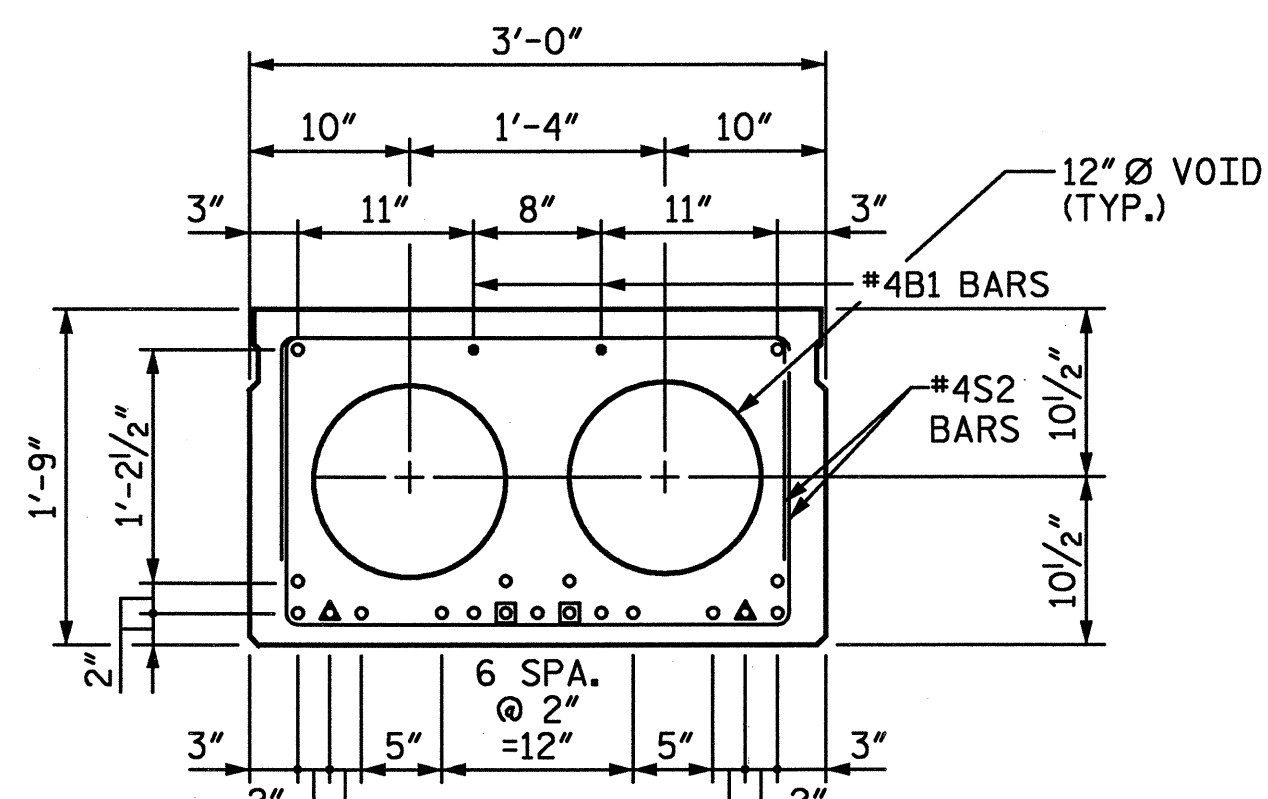

**SPANS A & E
INTERIOR SLAB SECTION**

(19 TOTAL STRANDS REQUIRED)

- DENOTES 1/2" Ø L.R. STRANDS
- △ DENOTES SHEATHED STRAND. BOND SHALL BE BROKEN ON THESE STRANDS FOR A DISTANCE OF 4'-0" FROM END OF SLAB.
- ☒ DENOTES SHEATHED STRAND. BOND SHALL BE BROKEN ON THESE STRANDS FOR A DISTANCE OF 2'-0" FROM END OF SLAB.

SEE STANDARD SPECIFICATIONS ARTICLE 1078-7.

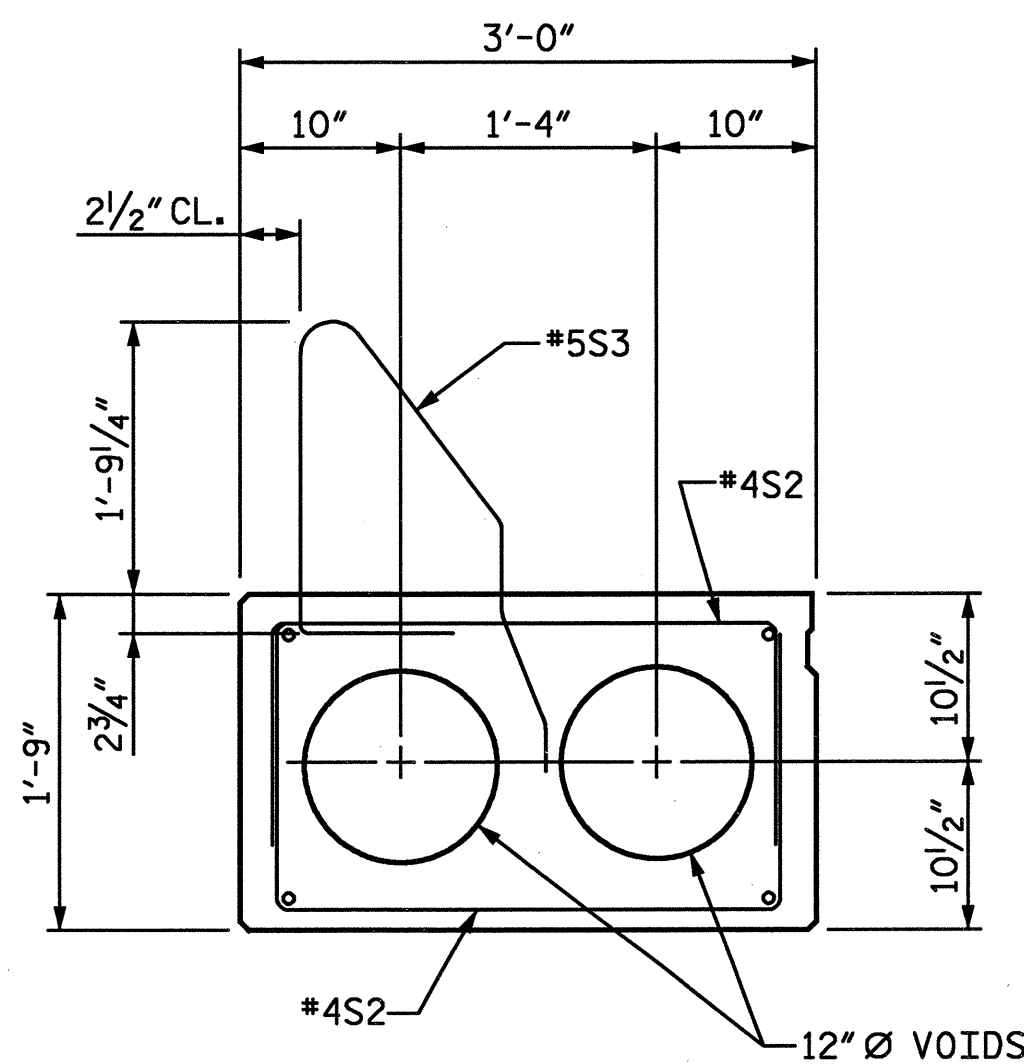

**SPANS A & E
EXTERIOR SLAB SECTION**

(FOR PRESTRESSED STRAND AND #4B1 BAR LAYOUT, SEE INTERIOR SLAB SECTION)

PROJECT NO. **B-5021**
ROBESON COUNTY
 BRIDGE: **162**

SHEET 2 OF 7

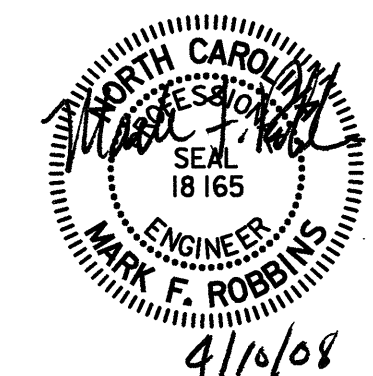
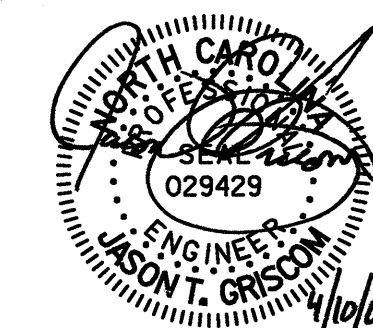

STATE OF NORTH CAROLINA
 DEPARTMENT OF TRANSPORTATION
 RALEIGH

**3'-0" X 1'-9"
 PRESTRESSED
 CORED SLAB**

REVISIONS

NO.	BY:	DATE:	NO.	BY:	DATE:
1			3		
2			4		

SHEET NO.

5-32
 TOTAL SHEETS
 62

DRAWN BY: **LGH** DATE: **2-08**
 CHECKED BY: **TBQ** DATE: **2-08**

D-1809.32

STV / Ralph Whitehead Associates, Inc.
 1000 West Morehead St., Ste. 200
 Charlotte, NC 28208

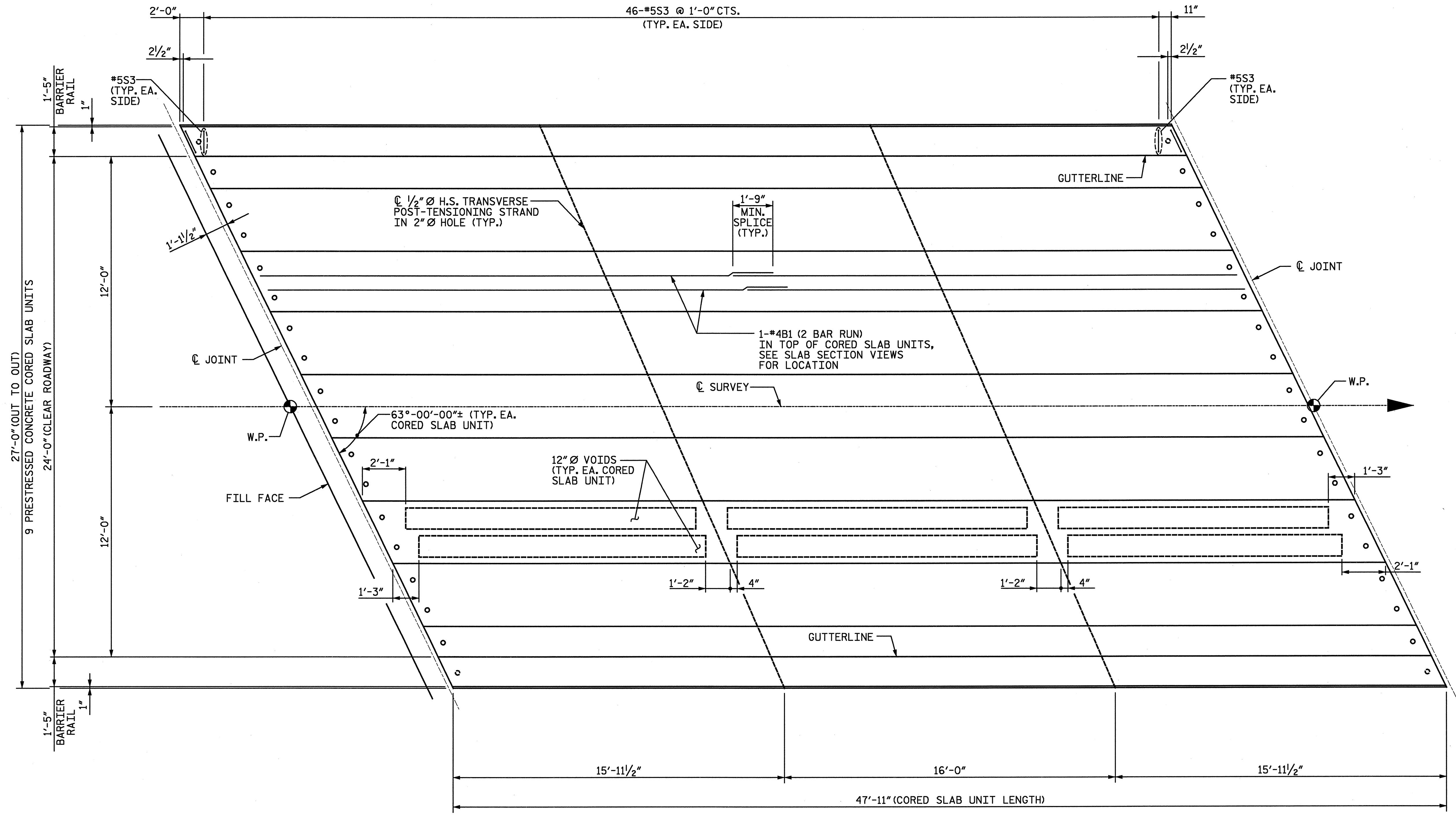

PLAN OF SPAN

(SPAN A SHOWN, SPAN E SIMILAR)

FOR ADDITIONAL CONCRETE RAIL REINFORCING STEEL & DETAILS, SEE "CONCRETE BRIDGE RAIL" SHEET.

PROJECT NO. **B-5021**

ROBESON COUNTY

BRIDGE: **162**

SHEET 3 OF 7

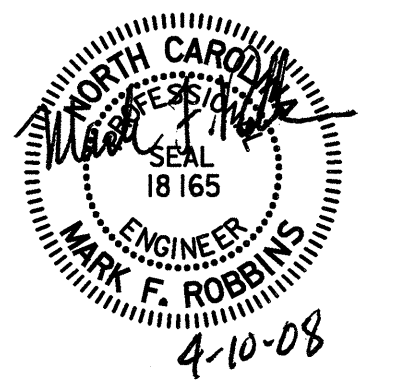
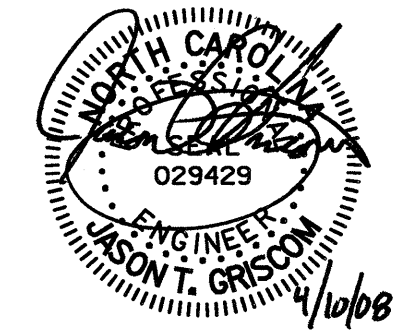

STATE OF NORTH CAROLINA
DEPARTMENT OF TRANSPORTATION
RALEIGH

**SUPERSTRUCTURE
PLAN OF SPAN A & E**

DRAWN BY: **LGH** DATE: **3-08**
CHECKED BY: **TBQ** DATE: **3-08**

4/10/2008
N:\PROJ\2513448\B5021\Bridg 162\Ustation\Finals\Plan of Span A&E.dgn

D-1809.33

STV / Ralph Whitehead Associates, Inc.
1000 West Morehead St., Ste. 200
Charlotte, NC 28208

REVISIONS						SHEET NO.
NO.	BY:	DATE:	NO.	BY:	DATE:	S-33
1			3			TOTAL SHEETS
2			4			62

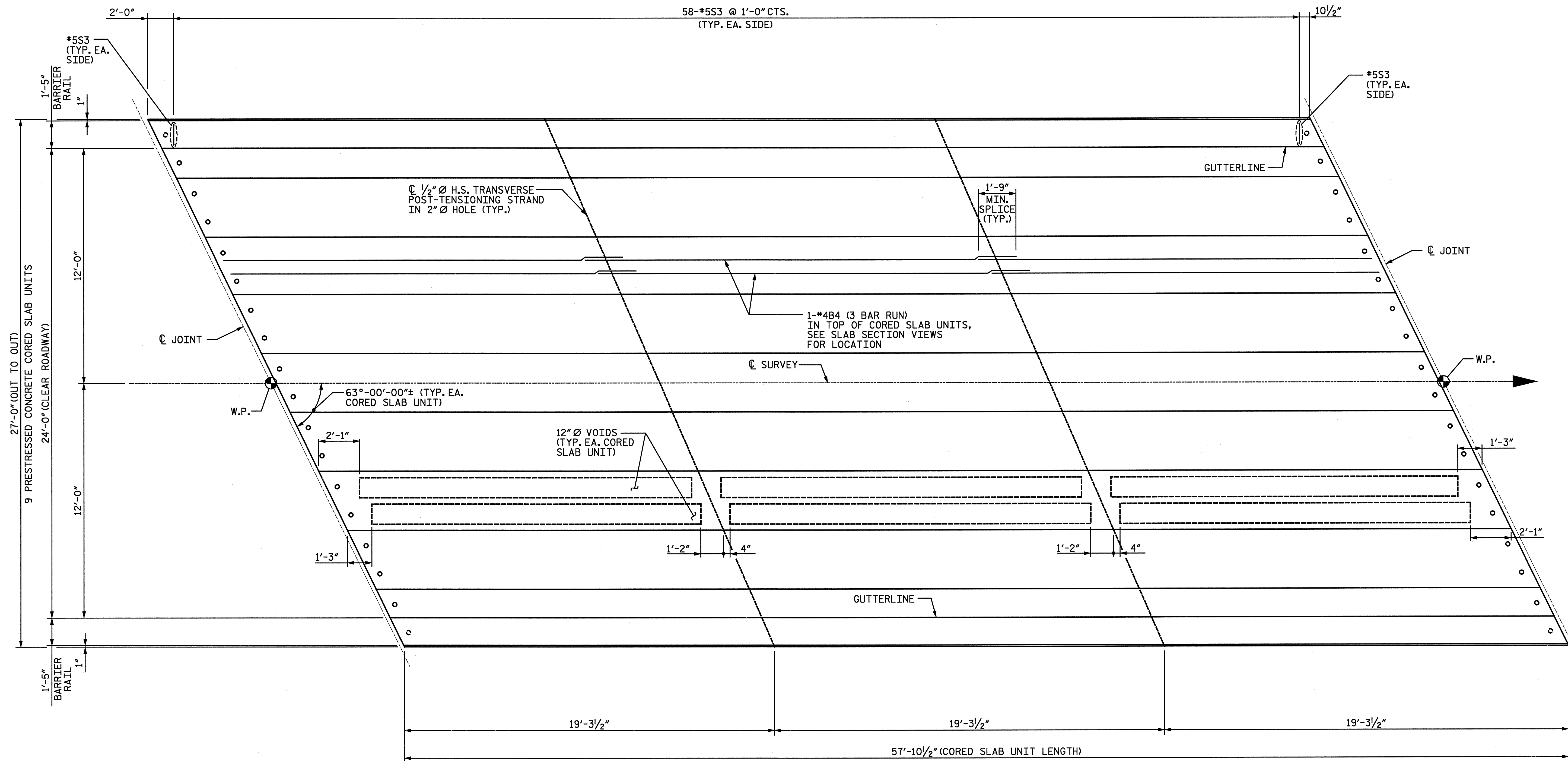

PLAN OF SPAN

FOR ADDITIONAL CONCRETE RAIL REINFORCING STEEL & DETAILS, SEE "CONCRETE BRIDGE RAIL" SHEET.

PROJECT NO. **B-5021**

ROBESON COUNTY

BRIDGE: **162**

SHEET 4 OF 7

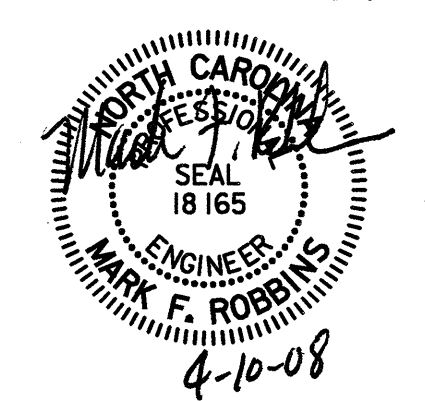
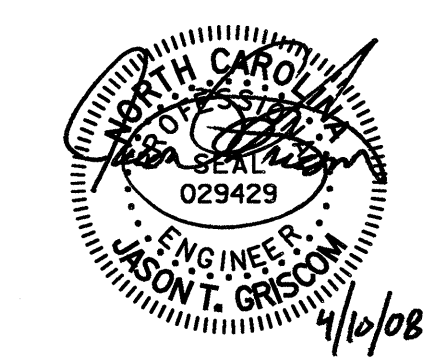

STATE OF NORTH CAROLINA
 DEPARTMENT OF TRANSPORTATION
 RALEIGH

**SUPERSTRUCTURE
 PLAN OF SPAN B-D**

DRAWN BY: **LGH** DATE: **3-08**
 CHECKED BY: **TBQ** DATE: **3-08**

4/10/2008
 N:\PROJ\2513448\B5021\Bridge 162\Station\Finals\Plan of Span B-D.dgn

D-1809.34
 STV/Ralph Whitehead Associates, Inc.
 1000 West Morehead St., Ste. 200
 Charlotte, NC 28208

REVISIONS						SHEET NO.
NO.	BY:	DATE:	NO.	BY:	DATE:	5-34
1			3			TOTAL SHEETS
2			4			62

NOTES:
FOR RAIL DETAILS, SEE SHEET 7 OF 7.

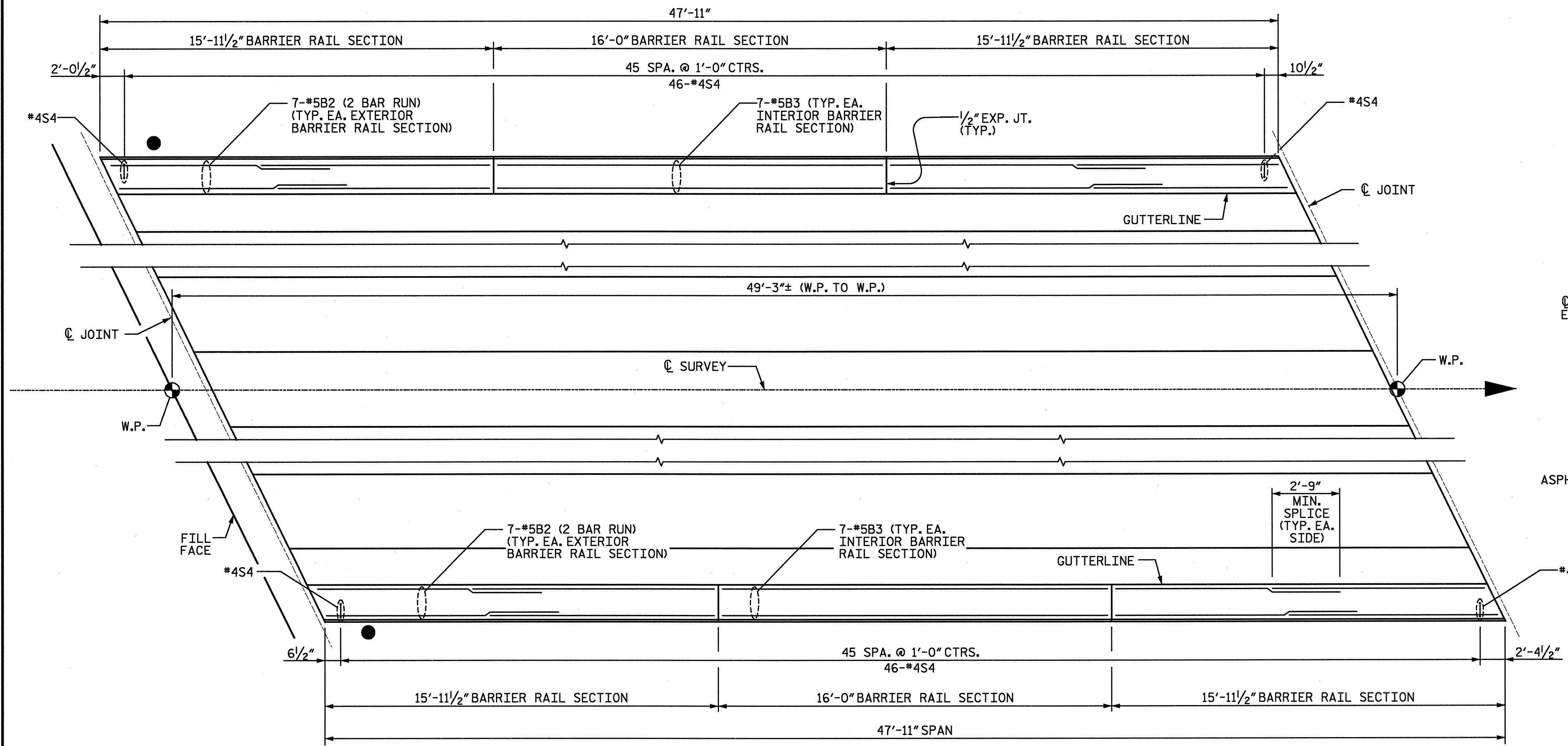

PLAN

(SPAN A SHOWN, SPAN E SIMILAR)
● LOCATION OF B-77 GUARDRAIL ATTACHMENT

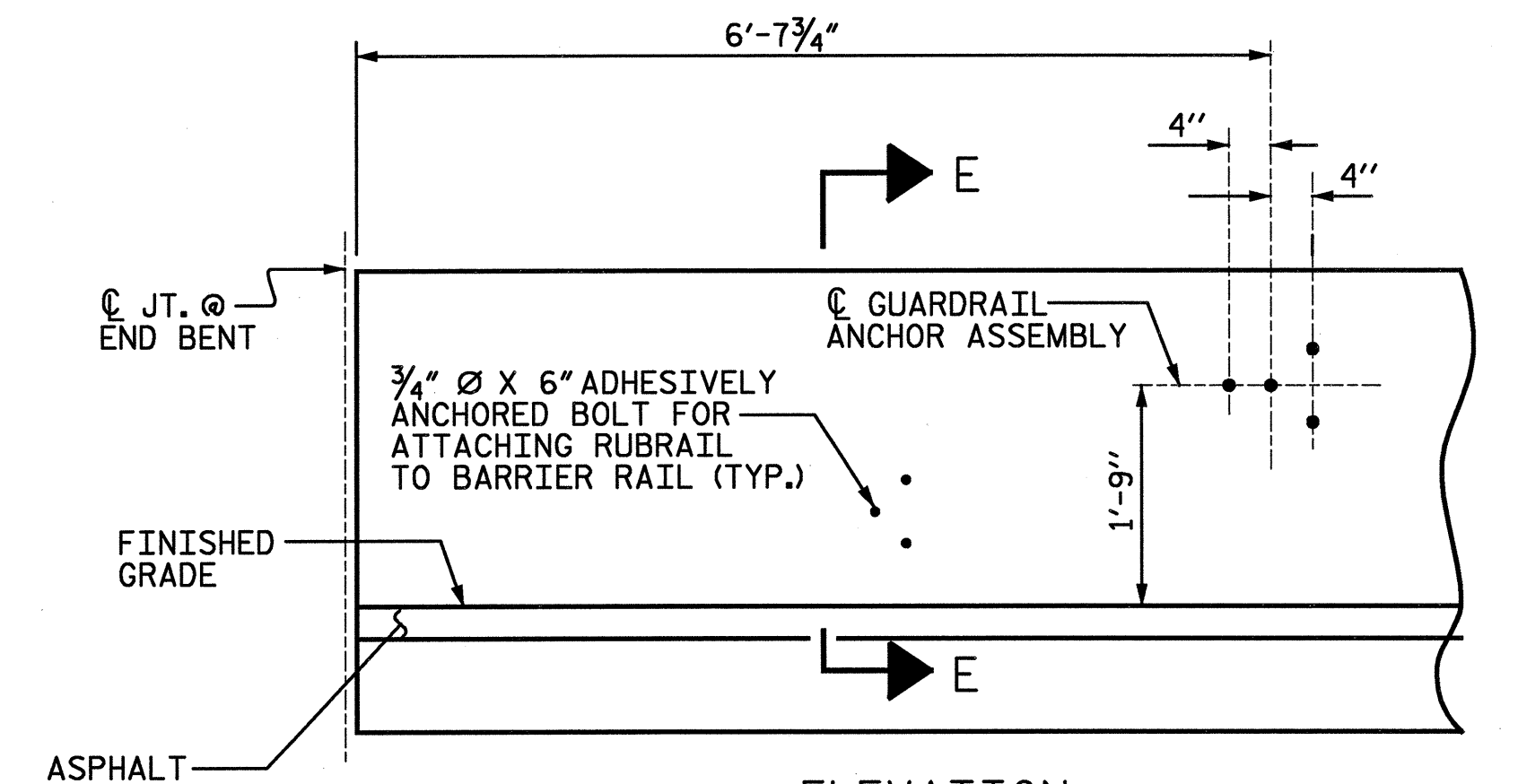

ELEVATION

FOR LOCATION OF RUBRAIL, SEE ROADWAY STD. 862.03

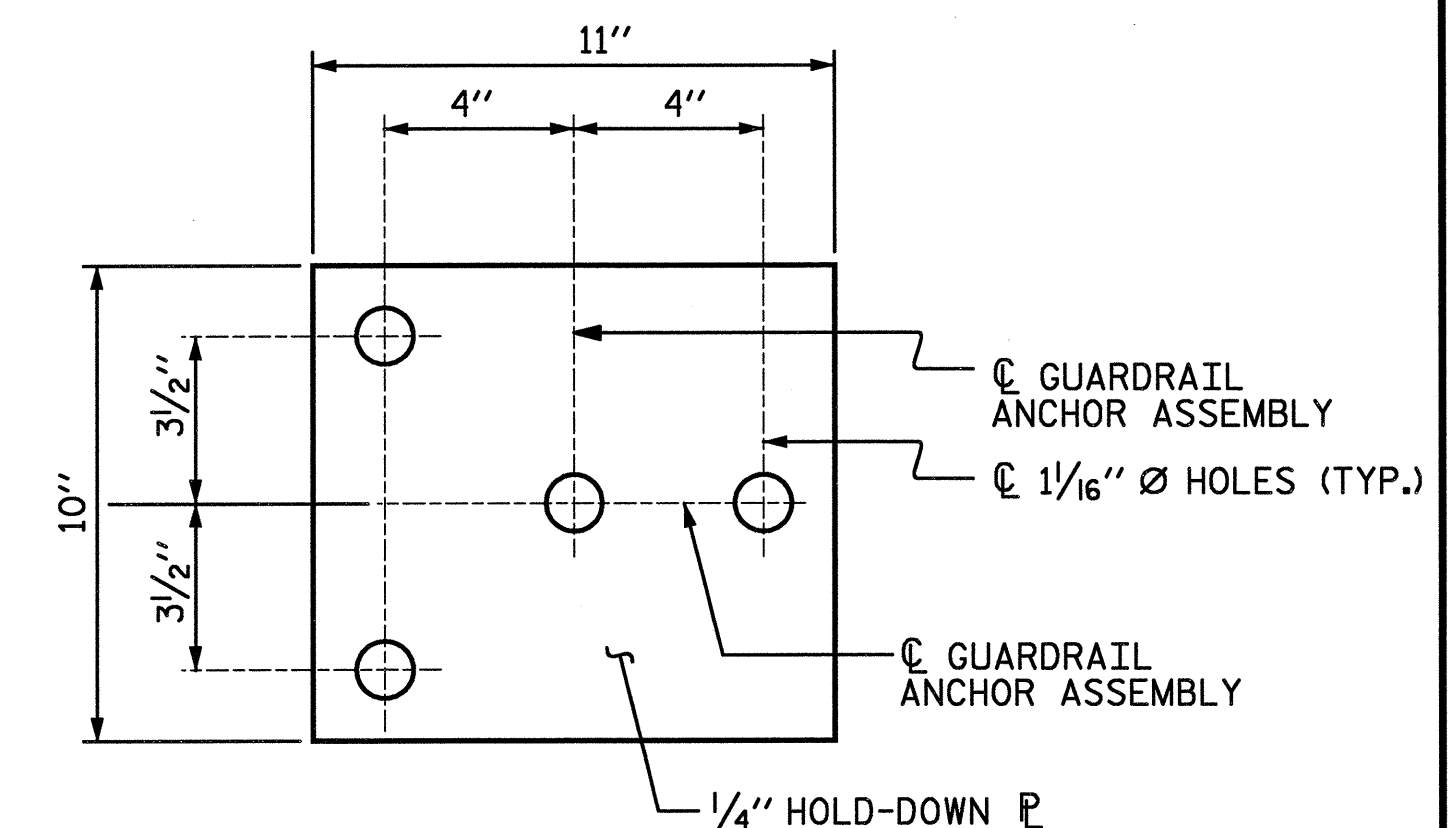

PLAN

LOCATION OF ANCHORS FOR GUARDRAIL

END BENT 1 SHOWN, END BENT 2 SIMILAR.

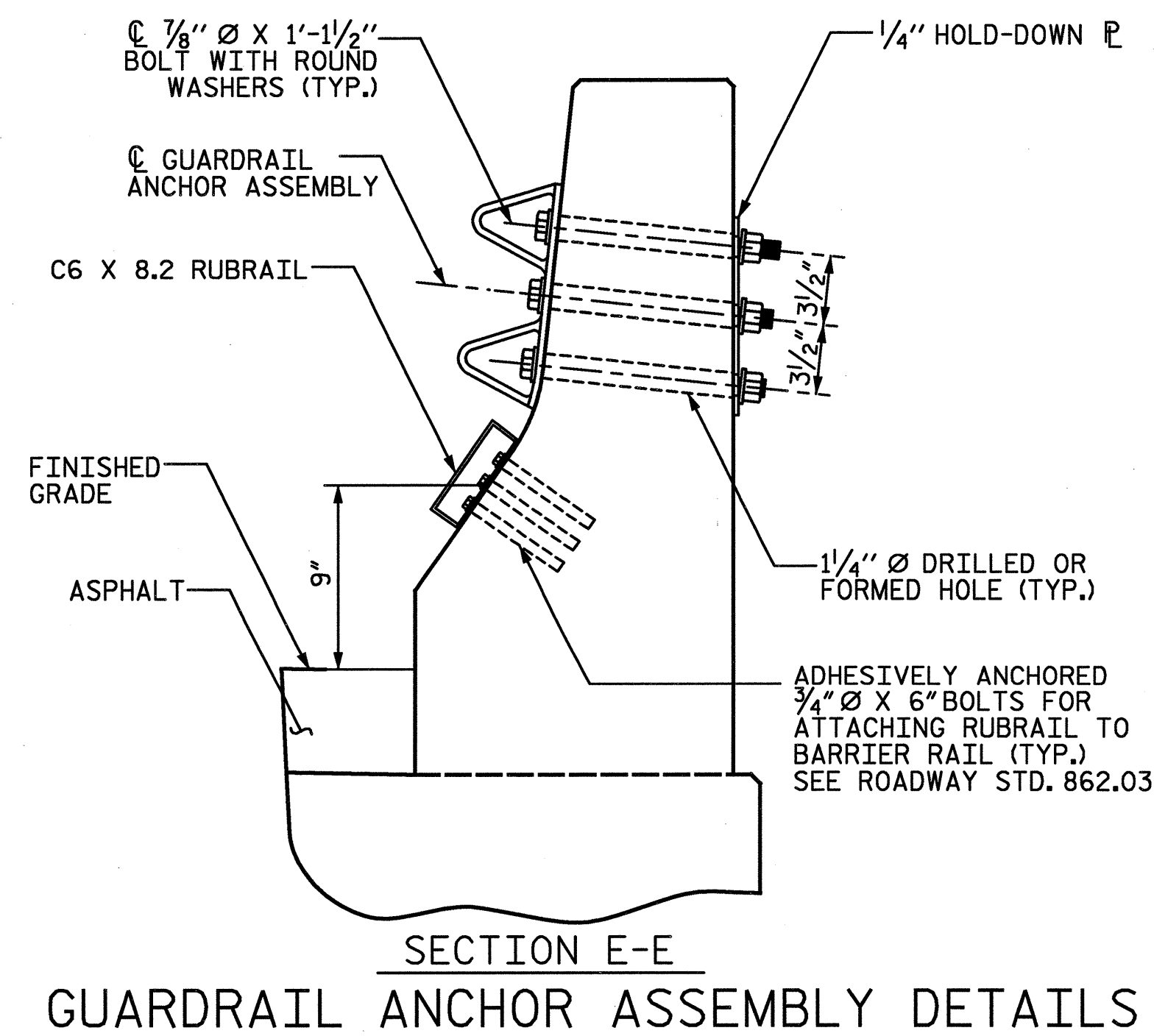

**SECTION E-E
GUARDRAIL ANCHOR ASSEMBLY DETAILS**

GUARDRAIL ANCHORAGE NOTES

THE GUARDRAIL ANCHOR ASSEMBLY SHALL CONSIST OF A 1/4\"/>

THE HOLD-DOWN PLATE SHALL CONFORM TO AASHTO M270 GRADE 36. AFTER FABRICATION, THE HOLD-DOWN PLATE SHALL BE HOT-DIP GALVANIZED IN ACCORDANCE WITH AASHTO M111.

BOLTS SHALL CONFORM TO THE REQUIREMENTS OF ASTM A307 AND NUTS SHALL CONFORM TO THE REQUIREMENTS OF AASHTO M291. BOLTS, NUTS AND WASHERS SHALL BE GALVANIZED. (AT THE CONTRACTOR'S OPTION, STAINLESS STEEL BOLTS, NUTS AND WASHERS MAY BE USED AS AN ALTERNATE FOR THE 7/8\"/>

THE GUARDRAIL ANCHOR ASSEMBLY IS REQUIRED AT ALL POINTS WHERE APPROACH GUARDRAIL IS TO BE ATTACHED TO THE END OF BARRIER RAIL. FOR POINTS OF ATTACHMENT, SEE SKETCH.

AFTER INSTALLATION, THE EXPOSED THREAD OF THE BOLT SHALL BE BURRED WITH A SHARP POINTED TOOL.

THE COST OF THE GUARDRAIL ANCHOR ASSEMBLY SHALL BE INCLUDED IN THE UNIT CONTRACT PRICE BID FOR CONCRETE BARRIER RAIL.

THE 1 1/4\"/>

THE C6 X 8.2 RUBRAIL IS TO BE ADHESIVELY ANCHORED TO THE RAIL USING THREE 3/4\"/>

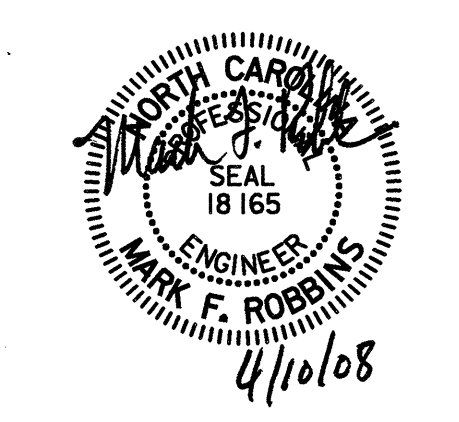
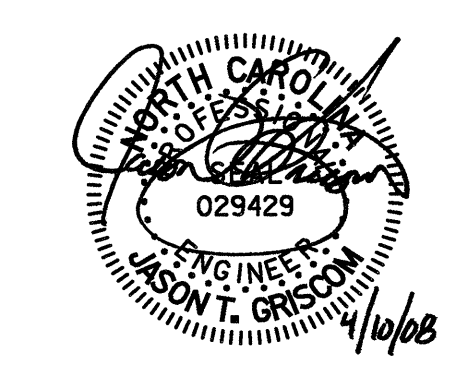

PROJECT NO. **B-5021**
ROBESON COUNTY
BRIDGE: **162**

SHEET 5 OF 7

STATE OF NORTH CAROLINA
DEPARTMENT OF TRANSPORTATION
RALEIGH

**SUPERSTRUCTURE
RAIL DETAILS
SPANS A & E**

REVISIONS

NO.	BY:	DATE:	NO.	BY:	DATE:
1			3		
2			4		

SHEET NO.
S- 35
TOTAL SHEETS
62

D-1809.35

STV/Ralph Whitehead Associates, Inc.
1000 West Morehead St., Ste. 200
Charlotte, NC 28208

DRAWN BY: LGH DATE: 3-08
CHECKED BY: TBQ DATE: 3-08

NOTES:
FOR RAIL DETAILS, SEE SHEET 7 OF 7.

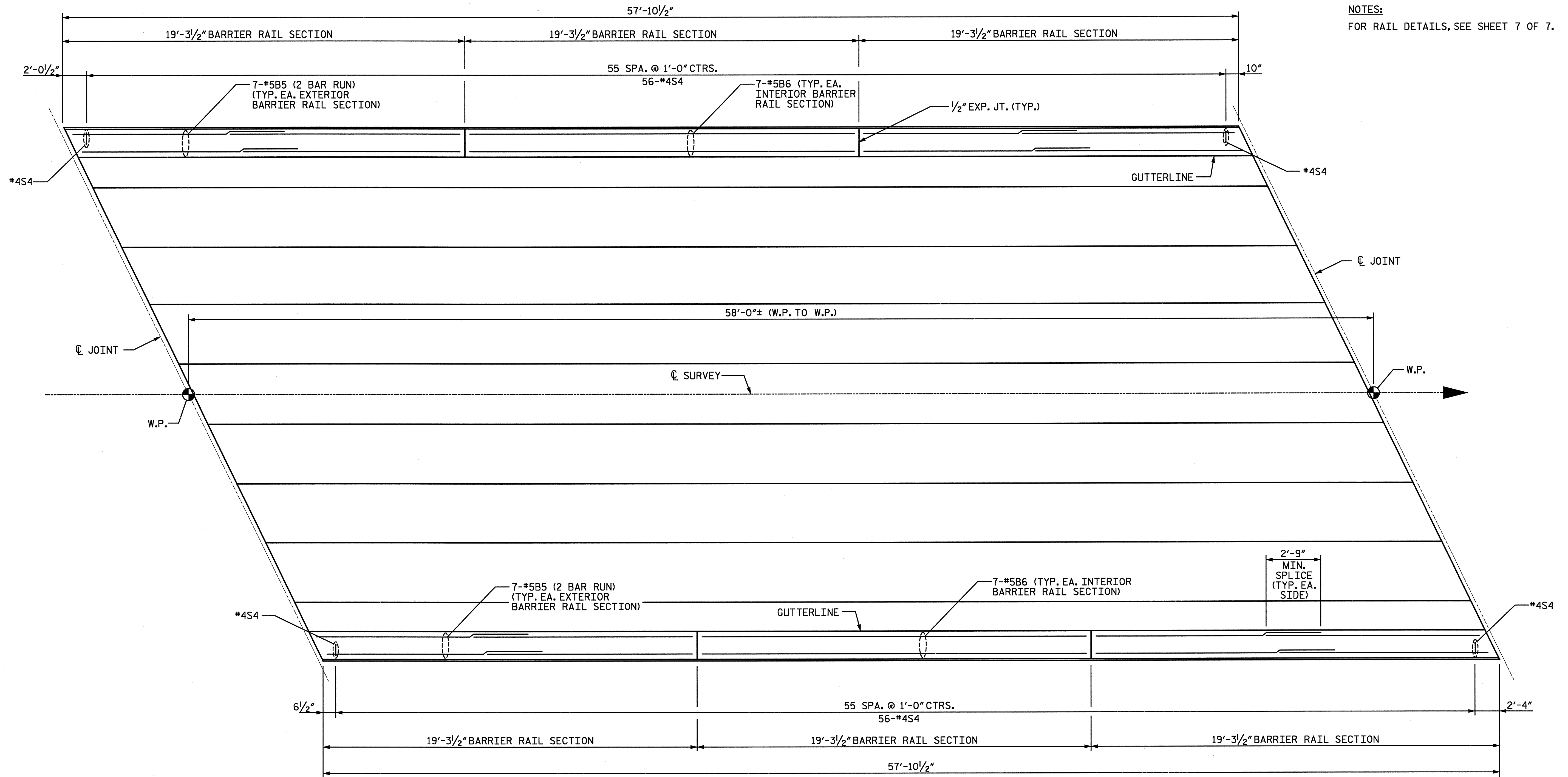

PLAN

PROJECT NO. B-5021
ROBESON COUNTY
 BRIDGE: 162

SHEET 6 OF 7

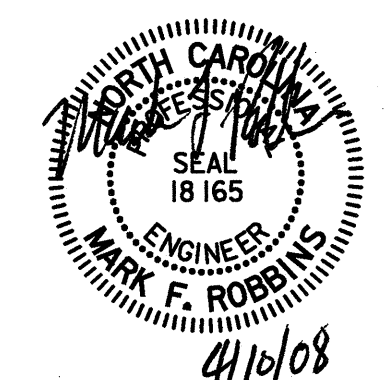
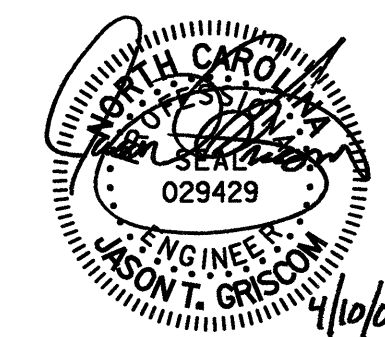

STATE OF NORTH CAROLINA
 DEPARTMENT OF TRANSPORTATION
 RALEIGH

SUPERSTRUCTURE
 RAIL DETAILS
 SPANS B-D

REVISIONS						SHEET NO.
NO.	BY:	DATE:	NO.	BY:	DATE:	S-36
1			3			TOTAL SHEETS
2			4			62

DRAWN BY: JWJ DATE: 3-08
 CHECKED BY: TBQ DATE: 3-08

D-1809.36

STV / Ralph Whitehead Associates, Inc.
 1000 West Morehead St., Ste. 200
 Charlotte, NC 28208

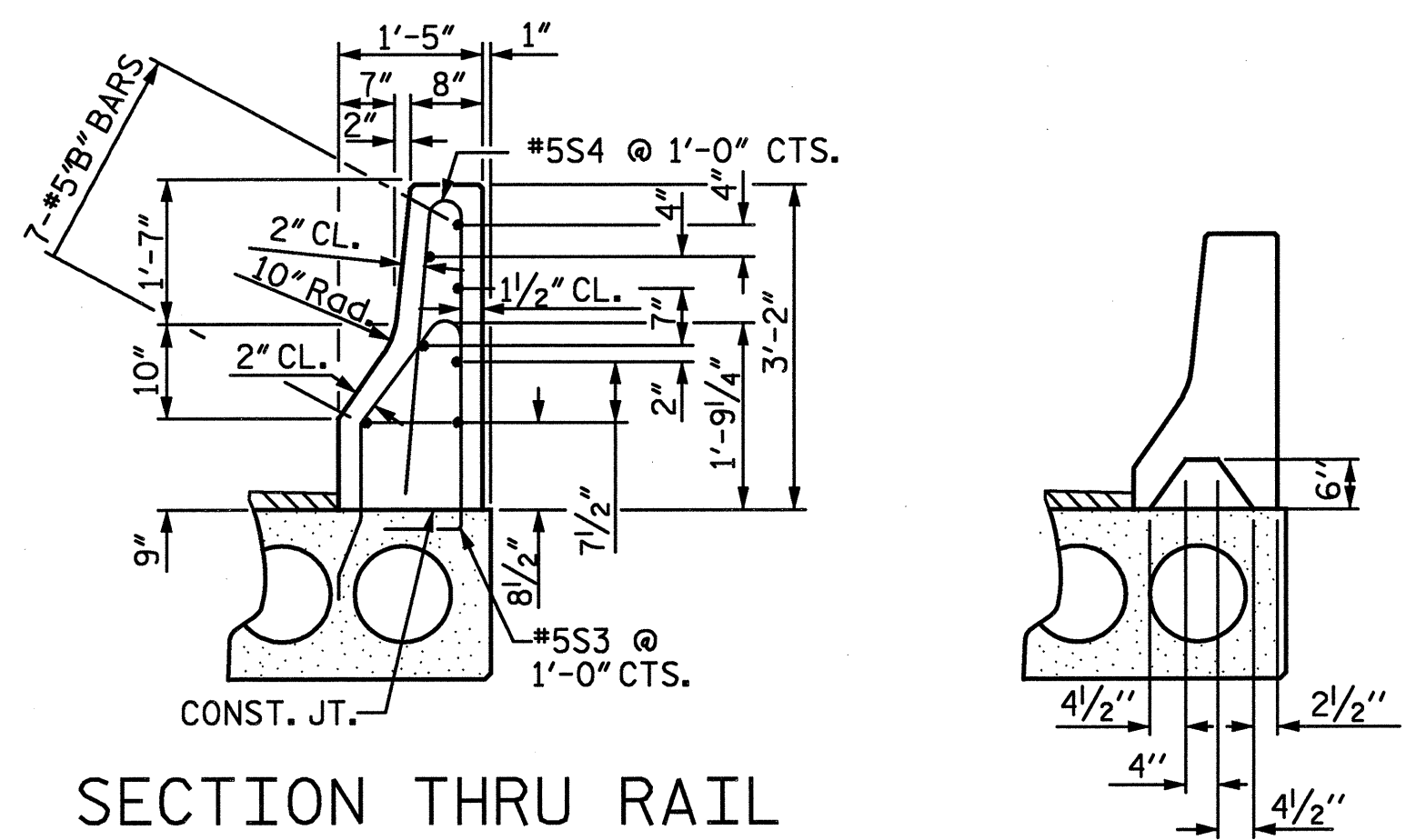

SECTION THRU RAIL

SECTION S-S

AT DAM IN OPEN JOINT
(THIS IS TO BE USED ONLY
WHEN SLIP FORM IS USED)

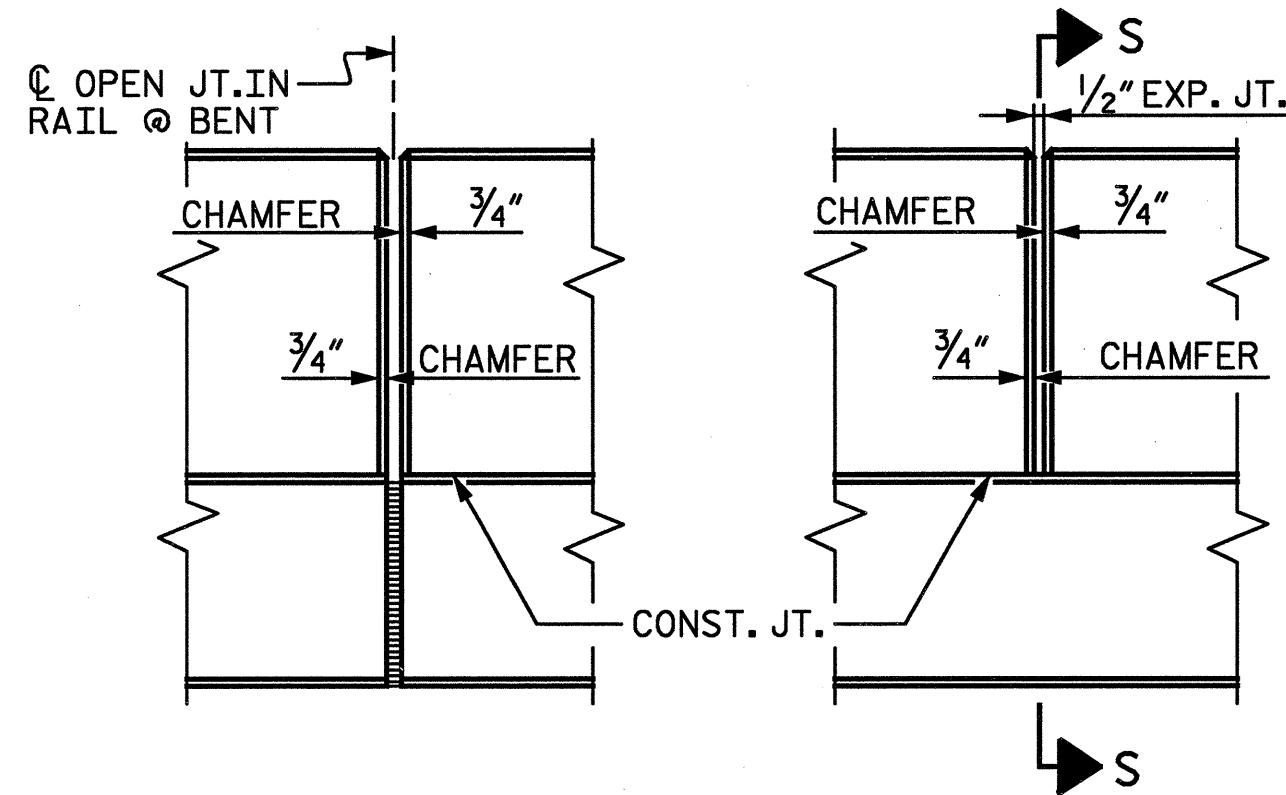

ELEVATION AT EXPANSION JOINTS

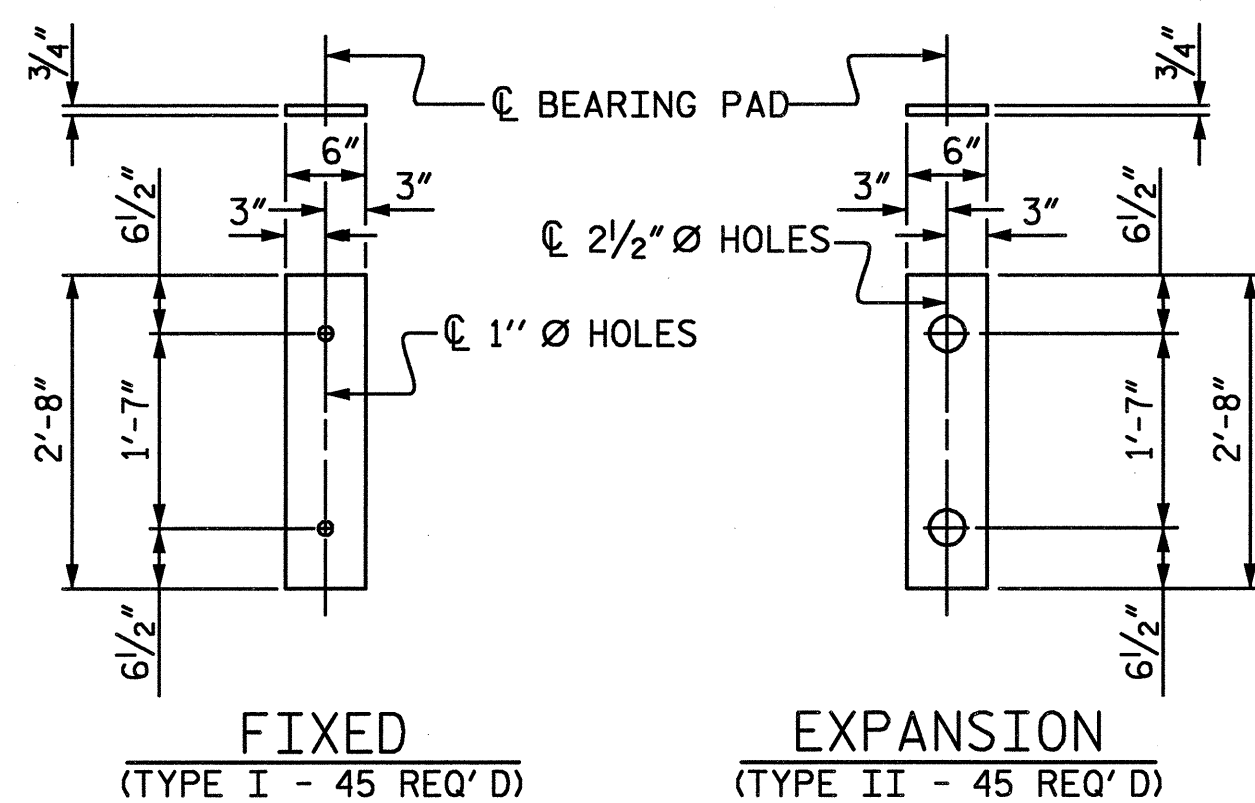

ELASTOMERIC BEARING DETAILS

BILL OF MATERIAL FOR CONCRETE BARRIER RAIL (PER SPAN, 2 REQ'D) SPANS A & E

BAR	TOTAL NO.	SIZE	TYPE	LENGTH	WEIGHT
*B2	56	#5	STR	9'-7"	560
*B3	14	#5	STR	15'-8"	229
*S4	92	#4	2	5'-11"	364
* EPOXY COATED REINFORCING STEEL					1,153 LBS.
CLASS AA CONCRETE					11.3 CY
TOTAL LIN. FT. OF CONCRETE BARRIER RAIL					95.8

BILL OF MATERIAL FOR CONCRETE BARRIER RAIL (PER SPAN, 3 REQ'D) SPANS B-D

BAR	TOTAL NO.	SIZE	TYPE	LENGTH	WEIGHT
*B5	56	#5	STR	11'-3"	657
*B6	14	#5	STR	18'-11"	276
*S4	112	#4	2	5'-11"	443
* EPOXY COATED REINFORCING STEEL					1,376 LBS.
CLASS AA CONCRETE					13.7 CY
TOTAL LIN. FT. OF CONCRETE BARRIER RAIL					115.8

DEAD LOAD DEFLECTION AND CAMBER

SPANS A & E	
CAMBER (SLAB ALONE IN PLACE)	1 3/8"
DEFLECTION DUE TO SUPERIMPOSED DEAD LOAD**	1/4"
FINAL CAMBER	1 1/8"

** INCLUDES FUTURE WEARING SURFACE

DEAD LOAD DEFLECTION AND CAMBER

SPANS B-D	
CAMBER (SLAB ALONE IN PLACE)	1 1/8"
DEFLECTION DUE TO SUPERIMPOSED DEAD LOAD**	1/16"
FINAL CAMBER	1 7/16"

** INCLUDES FUTURE WEARING SURFACE

CORED SLABS REQUIRED SPANS A & E

	NUMBER	LENGTH	TOTAL LENGTH
EXTERIOR C.S.	4	47'-11"	191'-8"
INTERIOR C.S.	14	47'-11"	670'-10"
TOTAL	18		862'-6"

CORED SLABS REQUIRED SPANS B-D

	NUMBER	LENGTH	TOTAL LENGTH
EXTERIOR C.S.	6	57'-10 1/2"	347'-3"
INTERIOR C.S.	21	57'-10 1/2"	1,215'-4 1/2"
TOTAL	27		1,562'-7 1/2"

BAR TYPES

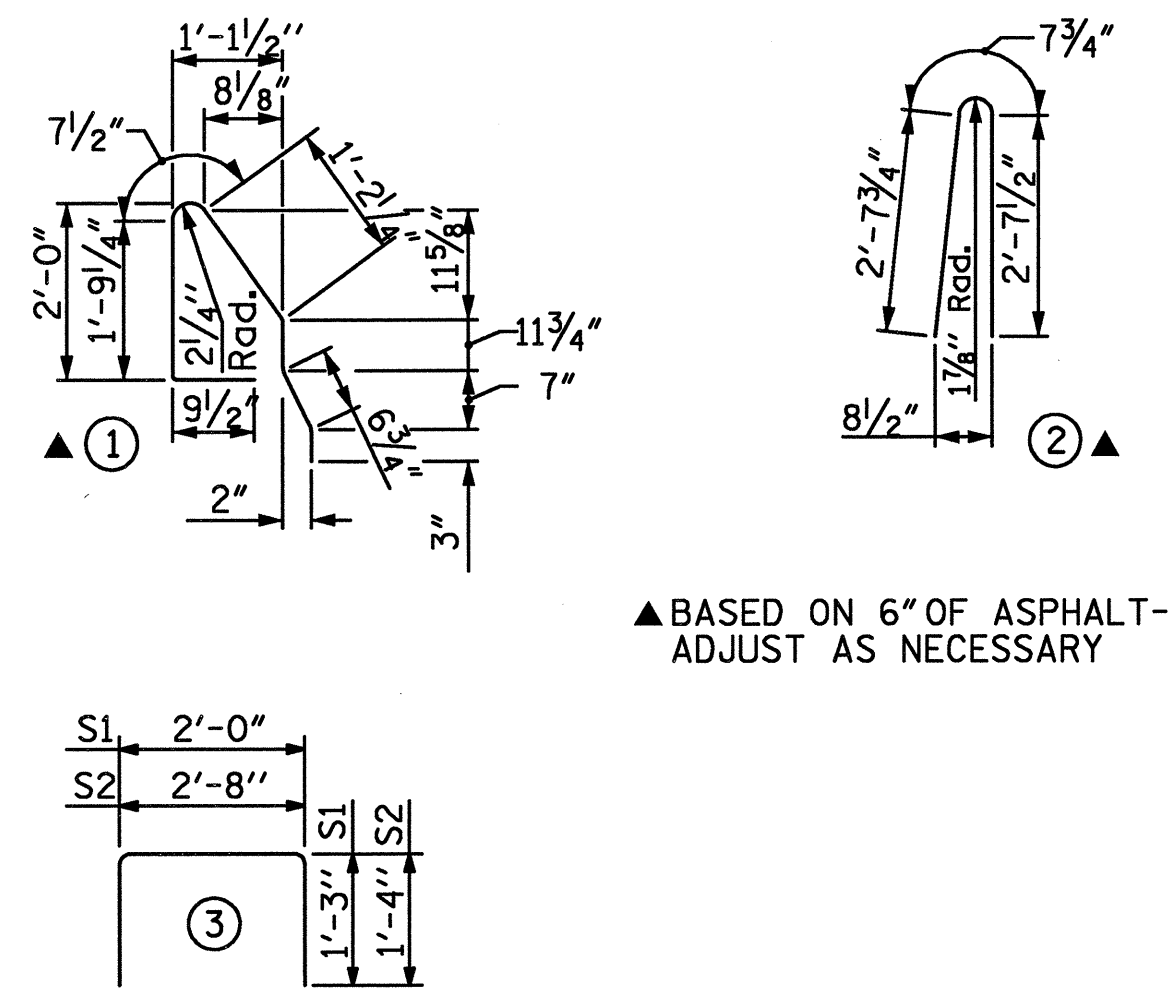

▲ BASED ON 6" OF ASPHALT - ADJUST AS NECESSARY

ALL BAR DIMENSIONS ARE OUT TO OUT

BILL OF MATERIAL FOR ONE CORED SLAB SECTION SPANS A & E

BAR	NUMBER	SIZE	TYPE	EXTERIOR UNIT LENGTH	EXTERIOR UNIT WEIGHT	INTERIOR UNIT LENGTH	INTERIOR UNIT WEIGHT
B1	4	#4	STR	24'-8"	66	24'-8"	66
S1	16	#4	3	4'-6"	48	4'-6"	48
S2	92	#4	3	5'-4"	328	5'-4"	328
*S3	48	#5	1	6'-2"	309		
REINFORCING STEEL				442 LBS.		442 LBS.	
* EPOXY COATED REINFORCING STEEL				309 LBS.			
5000 P.S.I. CONCRETE				6.9 CY		6.9 CY	
1/2" Ø L.R. STRANDS				No.	19		19

BILL OF MATERIAL FOR ONE CORED SLAB SECTION SPANS B-D

BAR	NUMBER	SIZE	TYPE	EXTERIOR UNIT LENGTH	EXTERIOR UNIT WEIGHT	INTERIOR UNIT LENGTH	INTERIOR UNIT WEIGHT
B4	6	#4	STR	20'-6"	82	20'-6"	82
S1	16	#4	3	4'-6"	48	4'-6"	48
S2	112	#4	3	5'-4"	399	5'-4"	399
*S3	60	#5	1	6'-2"	386		
REINFORCING STEEL				529 LBS.		529 LBS.	
* EPOXY COATED REINFORCING STEEL				386 LBS.			
7000 P.S.I. CONCRETE				8.3 CY		8.3 CY	
1/2" Ø L.R. STRANDS				No.	25		25

GRADE 270 STRANDS

	1/2" Ø L.R.
AREA (SQUARE INCHES)	0.153
ULTIMATE STRENGTH (LBS. PER STRAND)	41,300
APPLIED PRESTRESS (LBS. PER STRAND)	30,980

NOTES

ALL PRESTRESSING STRANDS SHALL BE 7-WIRE LOW RELAXATION GRADE 270 STRANDS AND SHALL CONFORM TO AASHTO M203 EXCEPT FOR SAMPLING REQUIREMENTS WHICH SHALL BE IN ACCORDANCE WITH THE STANDARD SPECIFICATIONS.

ALL REINFORCING STEEL CAST WITH THE CORED SLAB SECTIONS SHALL BE GRADE 60 AND SHALL BE INCLUDED IN THE UNIT PRICE BID FOR PRESTRESSED CONCRETE CORED SLABS.

RECESSES FOR TRANSVERSE STRANDS SHALL BE GROUTED AFTER THE TENSIONING OF THE STRANDS.

THE 2 1/2" Ø DOWEL HOLES AT FIXED ENDS OF SLAB SECTIONS SHALL BE FILLED WITH GROUT. THE 2 1/2" Ø DOWEL HOLES AT EXPANSION ENDS OF SLAB SECTIONS SHALL BE FILLED WITH JOINT SEALER MATERIAL TO 1/2" ABOVE THE TOP OF DOWELS AND THEN FILLED WITH GROUT.

THE JOINT SEALER MATERIAL SHALL CONFORM TO THE REQUIREMENTS OF TYPE SL LOW MODULUS SILICONE SEALANT. THE 2" Ø BACKER ROD SHALL CONFORM TO THE REQUIREMENTS OF TYPE M BOND BREAKER, SEE SECTION 1028 OF THE STANDARD SPECIFICATIONS. PAYMENT FOR JOINT SEALER MATERIAL SHALL BE CONSIDERED INCIDENTAL TO CONSTRUCTION OF THE BRIDGE.

WHEN CORED SLABS ARE CAST, A POSITIVE HOLD-DOWN SYSTEM SHALL BE EMPLOYED TO PREVENT VOIDS FROM RISING OR MOVING SIDEWAYS. THIS SYSTEM SHALL BE DESIGNED TO BE LEFT IN PLACE UNTIL THE CONCRETE HAS REACHED RELEASE STRENGTH. AT LEAST THREE WEEKS PRIOR TO CASTING CORED SLABS, THE CONTRACTOR SHALL SUBMIT TO THE ENGINEER FOR REVIEW AND COMMENT, DETAILED DRAWINGS OF THE PROPOSED HOLD-DOWN SYSTEM. IN ADDITION TO STRUCTURAL DETAILS, LOCATION AND SPACING OF THE HOLD-DOWNS SHALL BE INDICATED.

THE TRANSFER OF LOAD FROM THE ANCHORAGES TO THE CORED SLAB UNIT SHALL BE DONE WHEN THE CONCRETE HAS REACHED A COMPRESSIVE STRENGTH OF NOT LESS THAN 4000 PSI (SPANS A & E) AND 5600 PSI (SPANS B-D).

ALL REINFORCING STEEL IN BARRIER RAILS SHALL BE EPOXY COATED. PRESTRESSING STRANDS SHALL BE CUT FLUSH WITH THE CORED SLAB UNIT ENDS.

APPLY EPOXY PROTECTIVE COATING TO CORED SLAB UNIT ENDS.

VERTICAL GROOVED CONTRACTION JOINTS, 1/2" IN DEPTH, SHALL BE TOoled IN ALL EXPOSED FACES OF THE BRIDGE RAIL AND IN ACCORDANCE WITH ARTICLE 825-10(B) OF THE STANDARD SPECIFICATIONS. THE CONTRACTION JOINTS SHALL BE LOCATED AT A SPACING OF 8 FEET TO 10 FEET BETWEEN EXPANSION JOINTS AND NO CONTRACTION JOINTS ARE REQUIRED FOR THOSE SEGMENTS LESS THAN 10 FEET IN LENGTH.

SUPERSTRUCTURE REINFORCING STEEL LENGTHS ARE BASED ON THE FOLLOWING MINIMUM SPLICE LENGTHS

BAR SIZE	SUPERSTRUCTURE EXCEPT APPROACH SLABS, PARAPET, AND BARRIER RAIL		APPROACH SLABS		PARAPET AND BARRIER RAIL
	EPOXY COATED	UNCOATED	EPOXY COATED	UNCOATED	
#4	2'-0"	1'-9"	2'-0"	1'-9"	2'-9"
#5	2'-6"	2'-2"	2'-6"	2'-2"	3'-5"
#6	3'-0"	2'-7"	3'-10"	2'-7"	4'-4"
#7	5'-3"	3'-6"			
#8	6'-10"	4'-7"			

PROJECT NO. B-5021

ROBESON COUNTY

BRIDGE: 162

SHEET 7 OF 7

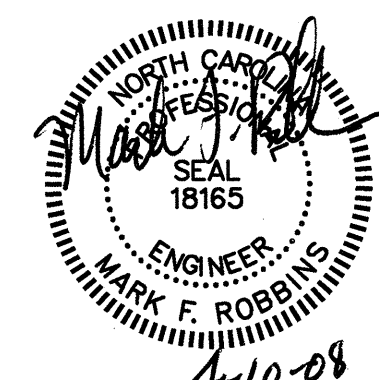
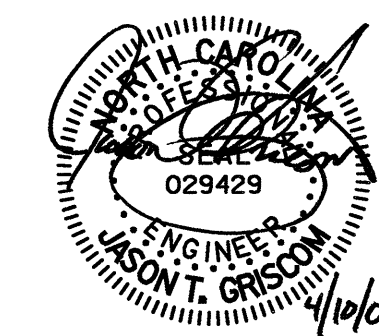

STATE OF NORTH CAROLINA
DEPARTMENT OF TRANSPORTATION
RALEIGH

SUPERSTRUCTURE CONCRETE BRIDGE RAIL DETAILS

REVISIONS

NO.	BY:	DATE:	NO.	BY:	DATE:
1			3		
2			4		

SHEET NO.

S-37
TOTAL SHEETS
62

D-1809.37

STV/Ralph Whitehead Associates, Inc.
1000 West Morehead St., Ste. 200
Charlotte, NC 28208

DRAWN BY: JTG DATE: 3-08
CHECKED BY: TBQ DATE: 3-08

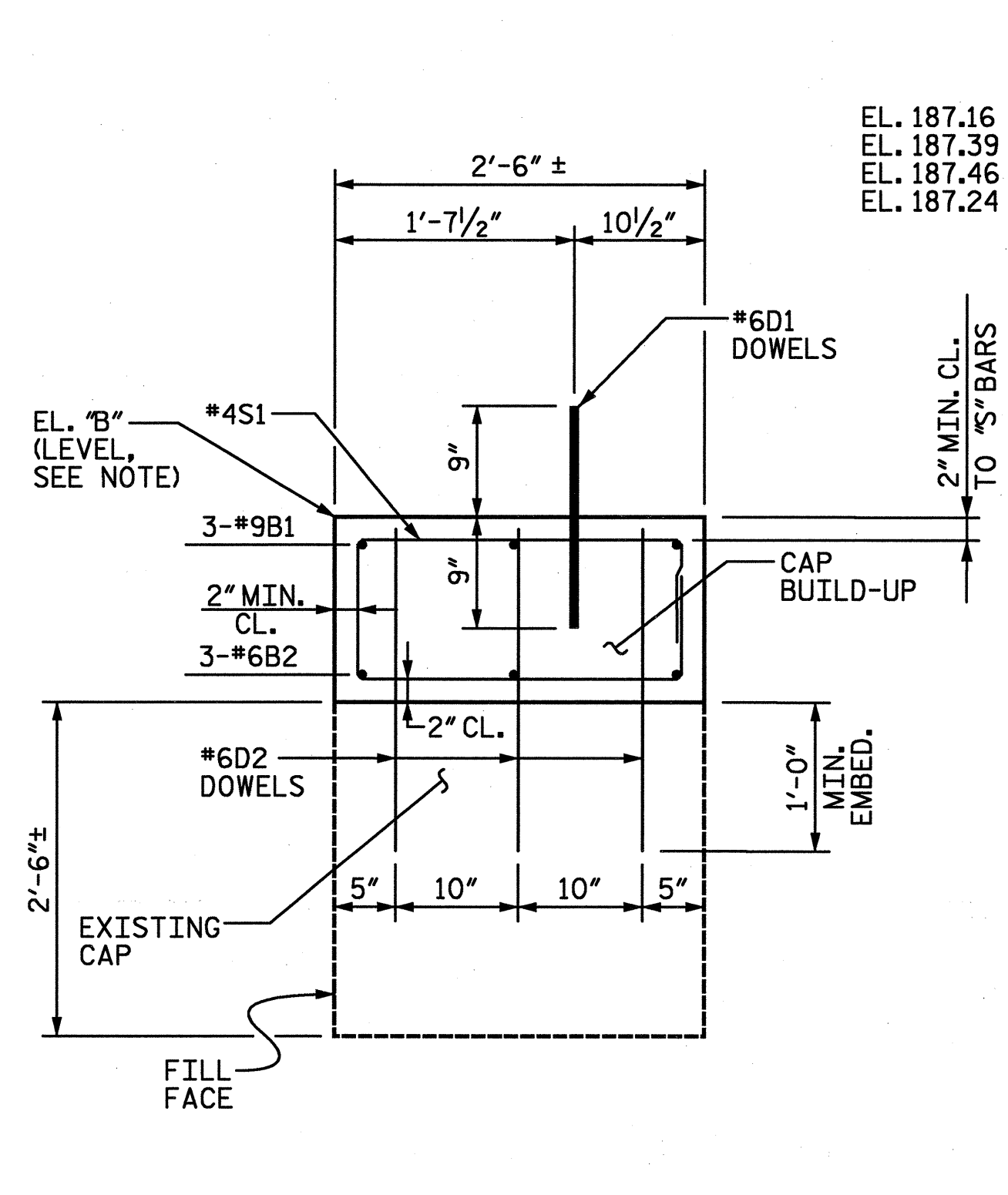

SECTION A-A

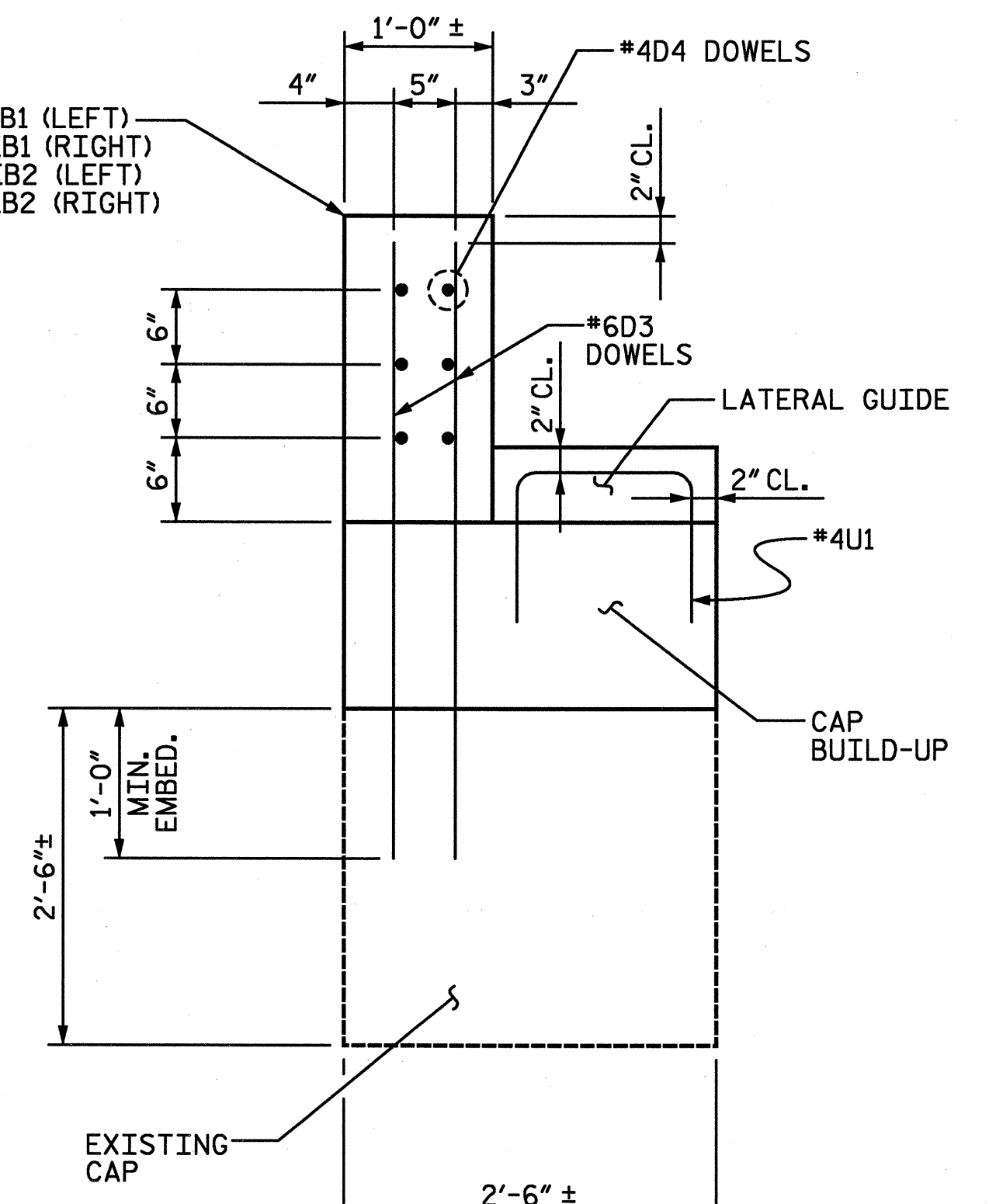

SECTION B-B

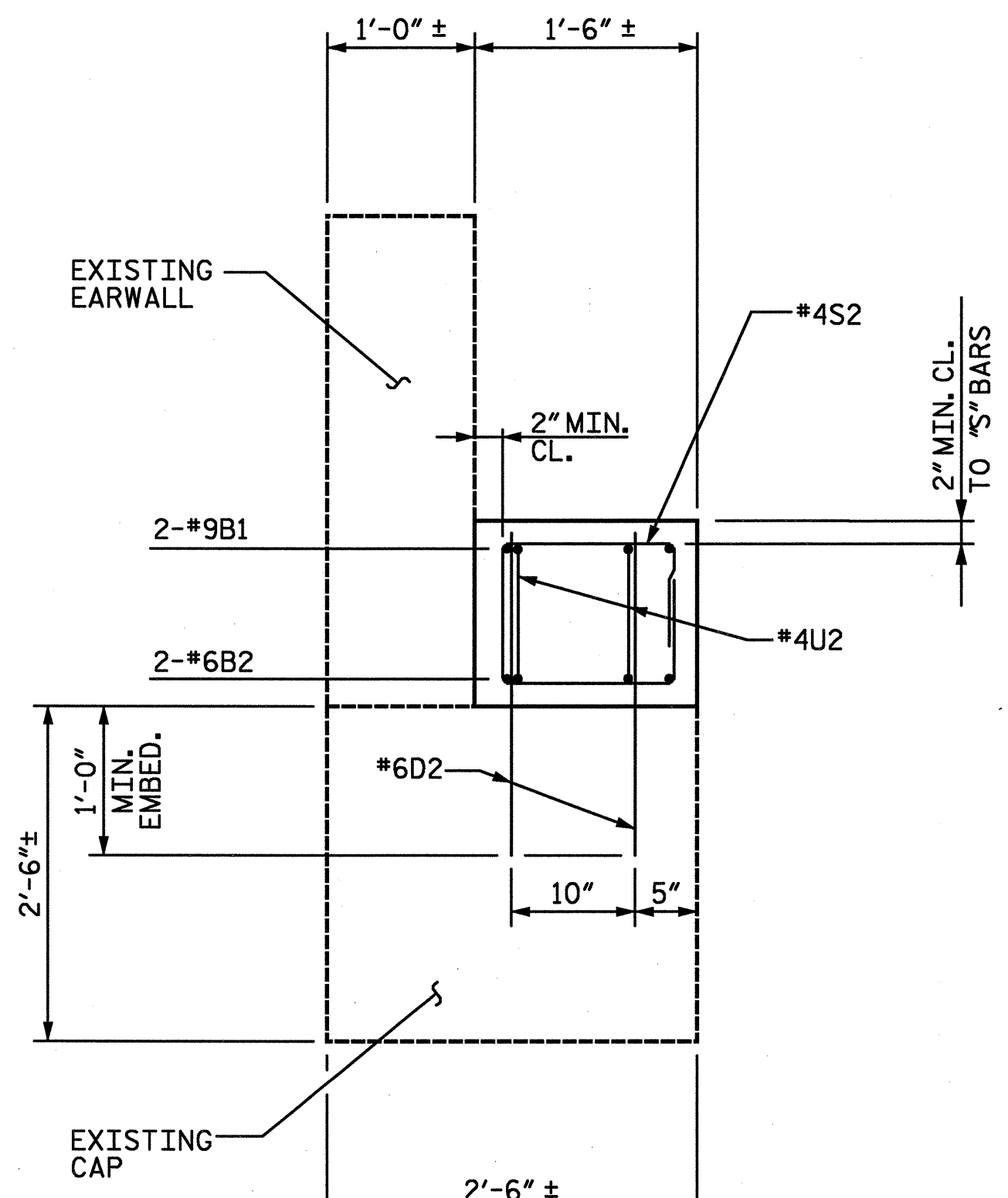

SECTION C-C

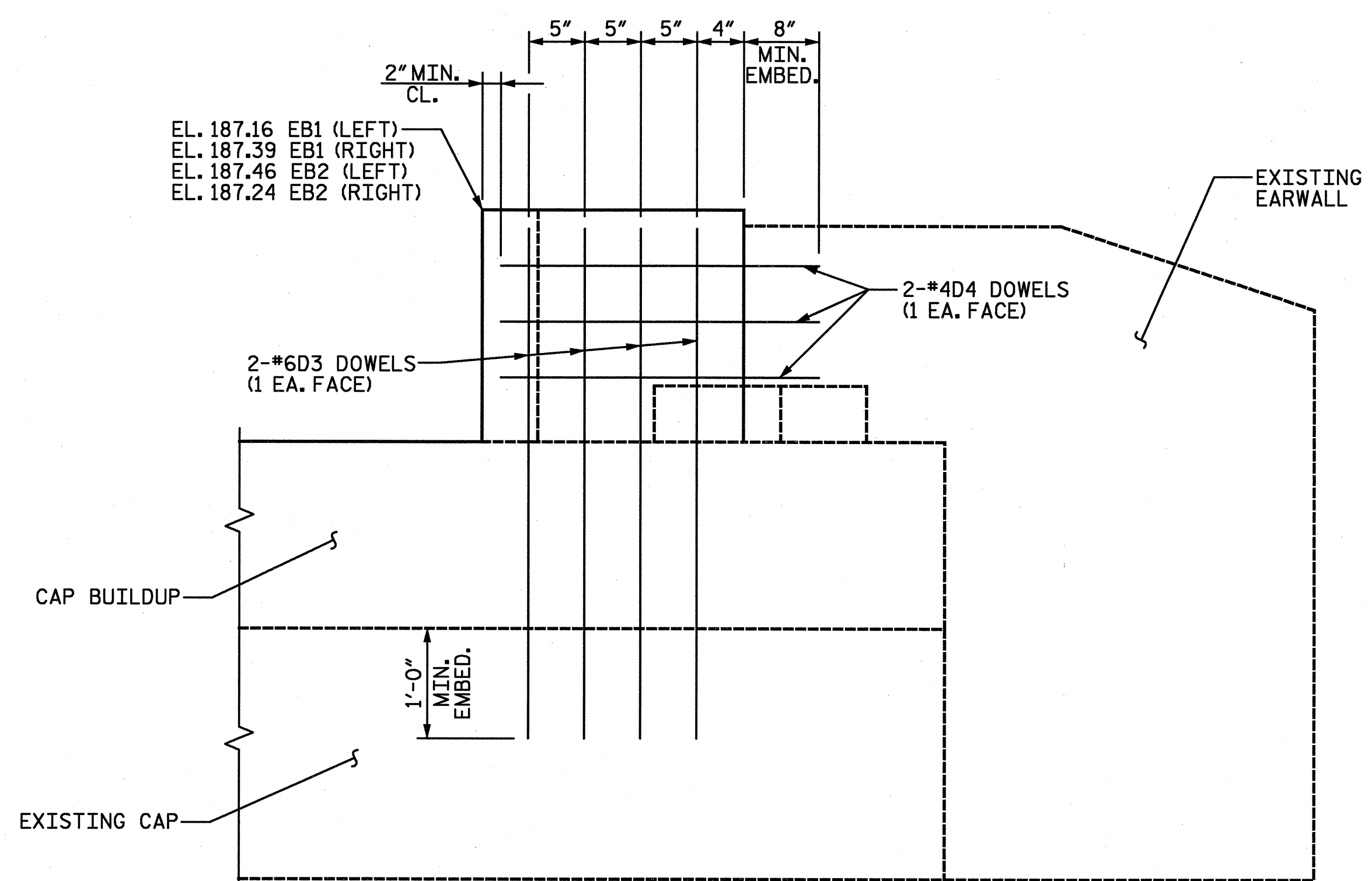

ELEVATION
(RIGHT SIDE SHOWN, LEFT SIDE SIMILAR)
CAST-IN-PLACE BACKWALL

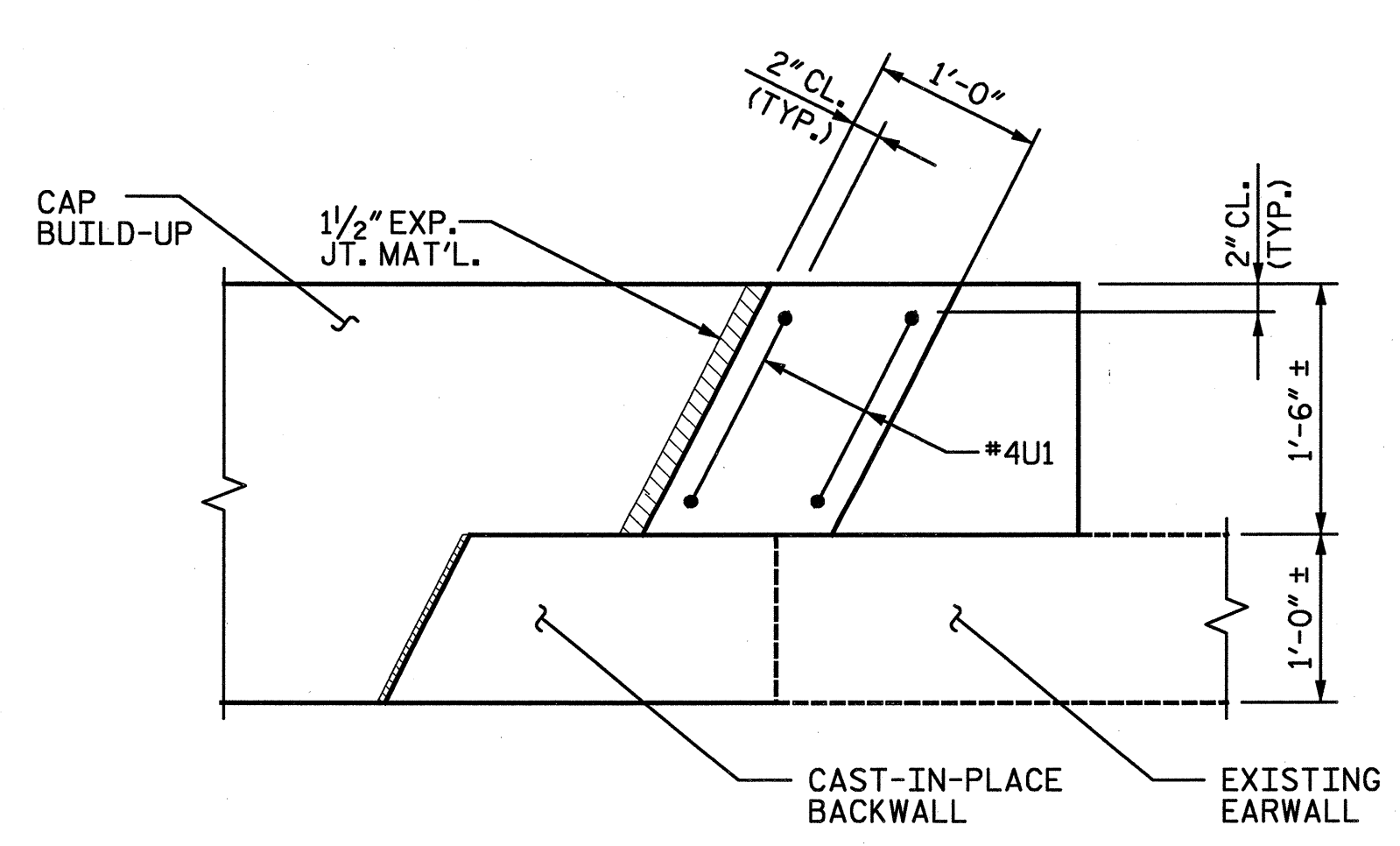

PLAN
LATERAL GUIDE DETAIL

BAR TYPES

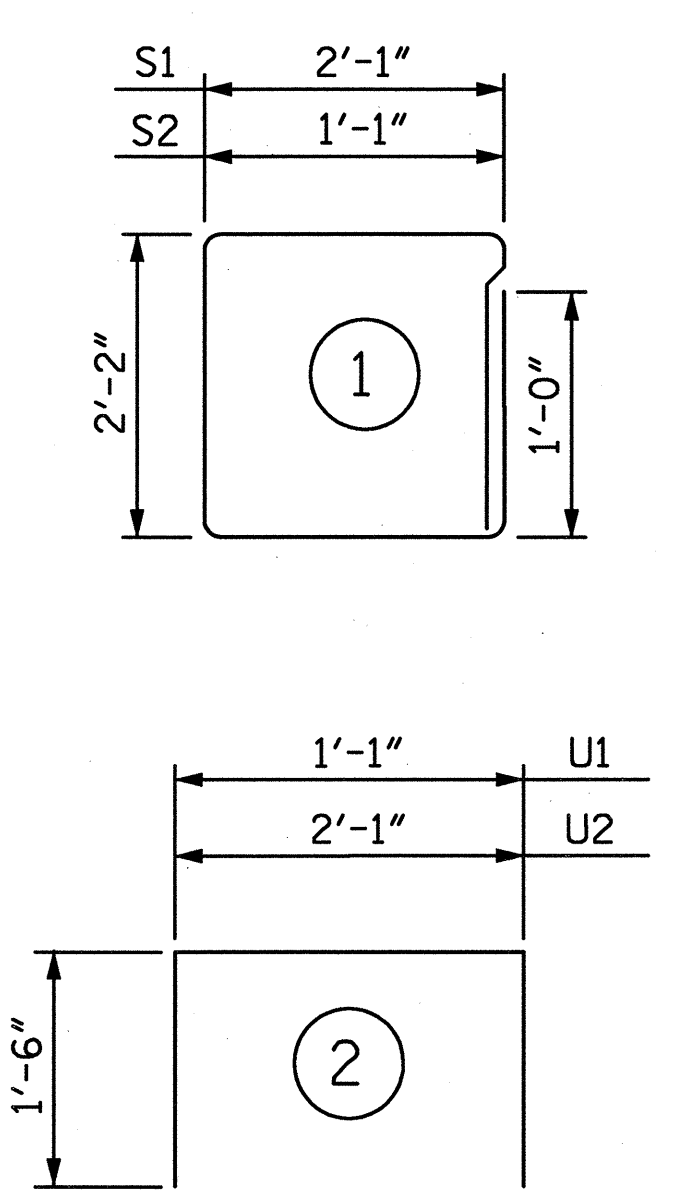

BILL OF MATERIAL

BILL OF REINFORCING FOR ONE END BENT (2 REQ'D.)

BAR	NO.	SIZE	TYPE	LENGTH	WEIGHT
B1	3	9	STR.	35'-0"	357
B2	3	6	STR.	35'-0"	158
D1	18	6	STR.	1'-6"	41
D2	102	6	STR.	3'-4"	511
D3	16	6	STR.	5'-8"	136
D4	12	4	STR.	2'-6"	20
S1	32	4	①	9'-6"	203
S2	3	4	①	7'-6"	15
U1	4	4	②	4'-1"	11
U2	4	4	②	5'-1"	14
REINFORCING STEEL				LBS.	1,466
CLASS AA CONCRETE BREAKDOWN					
POUR 1 (CAP)				CY	8.3
POUR 2 (LATERAL GUIDE)				CY	0.1
POUR 3 (BACKWALL)				CY	0.4
TOTAL				CY	8.8

NOTES :

- REINFORCING STEEL MAY BE SHIFTED AS NECESSARY TO CLEAR DOWELS.
- THE LATERAL GUIDES ARE NOT TO BE POURED UNTIL AFTER THE CORED SLAB UNITS ARE IN PLACE.
- THE BACKWALL IS NOT TO BE POURED UNTIL AFTER THE APPROACH SLAB IS IN PLACE.
- ALL ELEVATIONS ARE TO BE VERIFIED BY THE ENGINEER.
- ⚠ A HIGH EARLY STRENGTH PORTLAND CEMENT CONCRETE SHALL BE USED TO ACHIEVE A MINIMUM COMPRESSIVE STRENGTH OF 5000 PSI PRIOR TO PLACING CORED SLAB UNITS. SEE STANDARD SPECIFICATION SECTION 1000 FOR DETAILS.
- ⚠ #6D2, #6D3, AND #6D4 DOWELS SHALL BE ADHESIVELY ANCHORED USING AN APPROVED ADHESIVE CONSIDERING LOAD RESISTANCE, IN-SERVICE AND INSTALLATION TEMPERATURE, AVAILABILITY OF COMPREHENSIVE INSTALLATION INSTRUCTIONS, AND CREEP. ANCHORS SHALL BE INSTALLED TO THE MINIMUM EMBEDMENT DEPTHS AS SHOWN ON PLANS. LEVEL ONE FIELD TESTING IS REQUIRED, AND THE YIELD LOAD OF THE DOWEL IS 26 KIPS. FOR ADHESIVELY ANCHORED DOWELS, SEE SPECIAL PROVISIONS.
- DIMENSIONS AND ELEVATIONS ARE BASED ON AS-BUILT DIMENSIONS AND FIELD SURVEY INFORMATION. CONTRACTOR SHALL FIELD VERIFY DIMENSIONS PRIOR TO CONSTRUCTION. REINFORCING AND CONCRETE CAP EXTENSIONS SHALL BE ADJUSTED TO MATCH FIELD VERIFIED DIMENSIONS PROVIDED THAT THE OUT-TO-OUT DIMENSIONS REMAIN AS DETAILED.

PROJECT NO. B-5021
ROBESON COUNTY
BRIDGE: 162
SHEET 2 OF 2

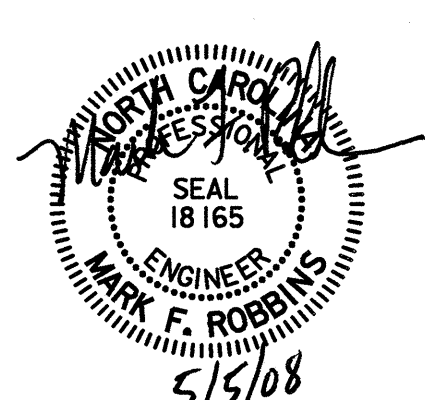
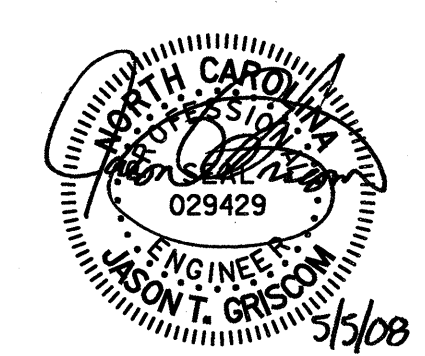

STATE OF NORTH CAROLINA
DEPARTMENT OF TRANSPORTATION
RALEIGH
SUBSTRUCTURE
END BENTS 1 & 2

DRAWN BY : LGH DATE : 3-08
CHECKED BY : BMC DATE : 3-08

REVISION #1: REVISED PER REVIEW COMMENTS
BY: TJT DATE: 5-08
CH'KD BY: KGB DATE: 5-08

D-1809.39
STV / Ralph Whitehead Associates, Inc.
1000 West Morehead St., Ste. 200
Charlotte, NC 28208

REVISIONS						SHEET NO.
NO.	BY:	DATE:	NO.	BY:	DATE:	S-39
1	STV	5-08	3			TOTAL SHEETS 62
2			4			

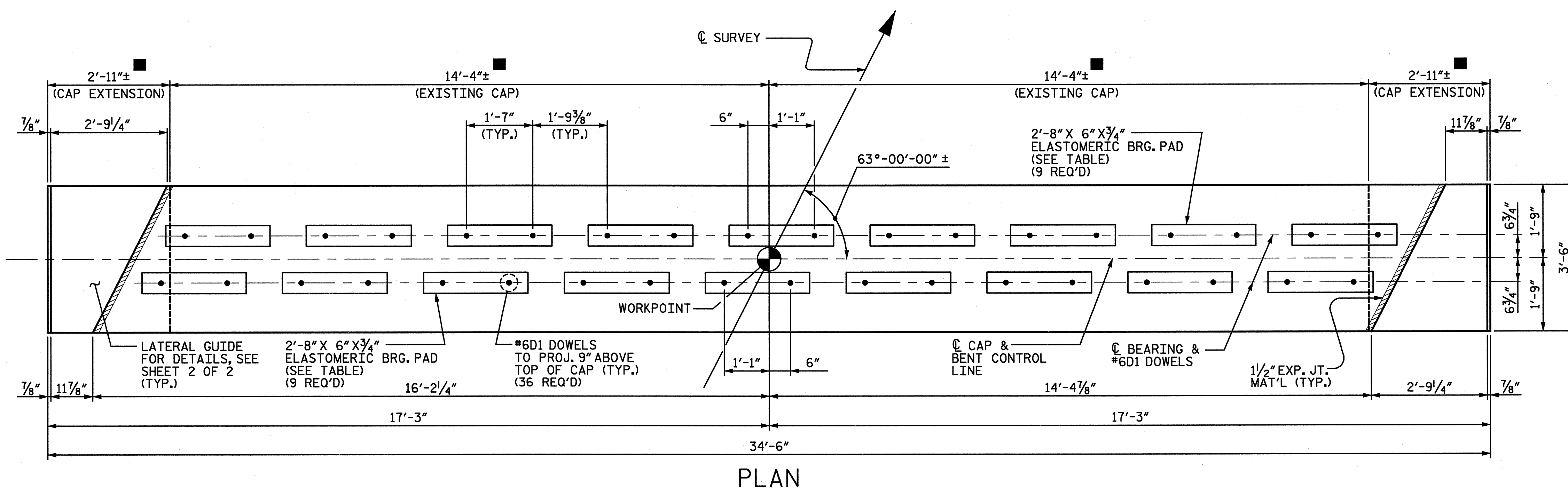

NOTES

REINFORCING STEEL MAY BE SHIFTED AS NECESSARY TO CLEAR DOWELS.
 THE LATERAL GUIDES ARE NOT TO BE POURED UNTIL AFTER THE CORED SLAB UNITS ARE IN PLACE.
 ALL ELEVATIONS ARE TO BE VERIFIED BY THE ENGINEER.
 A HIGH EARLY STRENGTH PORTLAND CEMENT CONCRETE SHALL BE USED TO ACHIEVE A MINIMUM COMPRESSIVE STRENGTH OF 5000 PSI PRIOR TO PLACING CORED SLAB UNITS. SEE STANDARD SPECIFICATION SECTION 1000 FOR DETAILS.
 *6D2, *6D3, *6D4, *6U2 DOWELS SHALL BE ADHESIVELY ANCHORED USING AN APPROVED ADHESIVE CONSIDERING LOAD RESISTANCE, IN-SERVICE AND INSTALLATION TEMPERATURE, AVAILABILITY OF COMPREHENSIVE INSTALLATION INSTRUCTIONS, AND CREEP. ANCHORS SHALL BE INSTALLED TO THE MINIMUM EMBEDMENT DEPTHS AS SHOWN ON PLANS. LEVEL ONE FIELD TESTING IS REQUIRED, AND THE YIELD LOAD OF THE DOWEL IS 26 KIPS. FOR ADHESIVELY ANCHORED DOWELS, SEE SPECIAL PROVISIONS.
 DIMENSIONS AND ELEVATIONS ARE BASED ON AS-BUILT DIMENSIONS AND FIELD SURVEY INFORMATION. CONTRACTOR SHALL FIELD VERIFY DIMENSIONS PRIOR TO CONSTRUCTION. REINFORCING AND CONCRETE CAP EXTENSIONS SHALL BE ADJUSTED TO MATCH FIELD VERIFIED DIMENSIONS PROVIDED THAT THE OUT-TO-OUT DIMENSIONS REMAIN AS DETAILED.

REVISION #1: REVISED PER REVIEW COMMENTS
 BY: TJT DATE: 5-08
 CH'KD BY: KGB DATE: 5-08

EXISTING CAP ELEVATIONS		
BENT	EL. "F"	EL. "G"
1	182.55	182.67
2	183.04	183.06
3	183.06	183.01
4	182.67	182.53

ELASTOMERIC BEARING PAD		
BENT	DOWNSTATION	UPSTATION
1	TYPE II	TYPE I
2	TYPE II	TYPE I
3	TYPE II	TYPE I
4	TYPE II	TYPE II

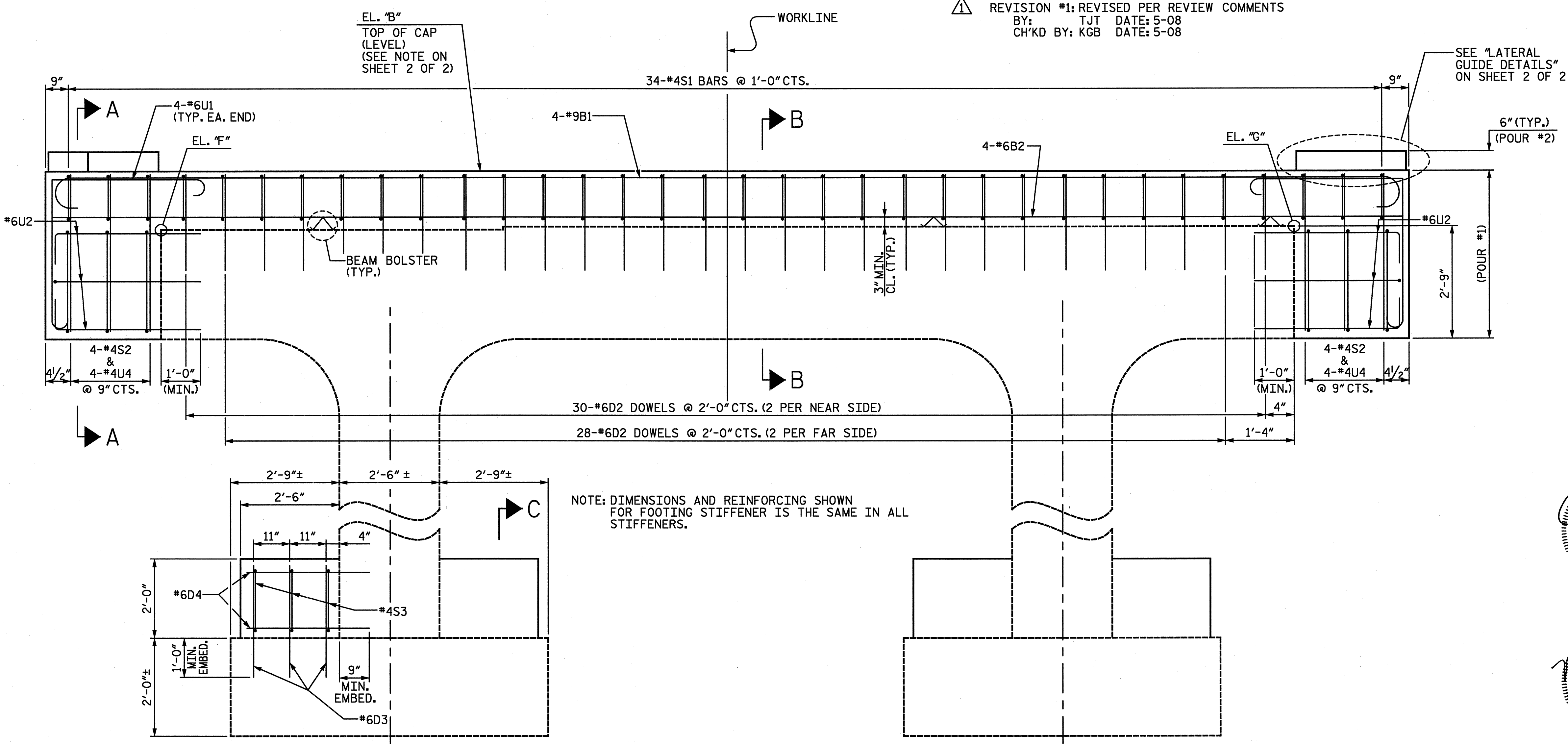

NOTE: DIMENSIONS AND REINFORCING SHOWN FOR FOOTING STIFFENER IS THE SAME IN ALL STIFFENERS.

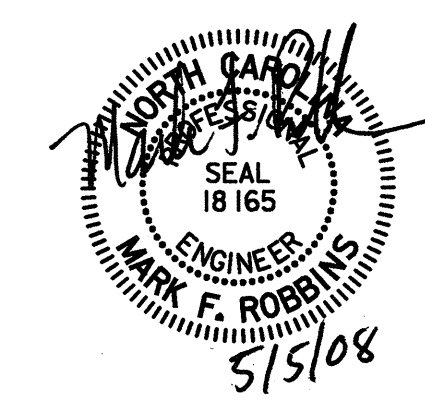
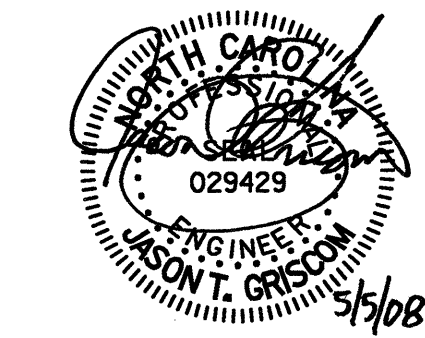

PROJECT NO. B-5021
 ROBESON COUNTY
 BRIDGE: 162
 SHEET 1 OF 2

STATE OF NORTH CAROLINA
 DEPARTMENT OF TRANSPORTATION
 RALEIGH

**SUBSTRUCTURE
 BENTS 1-4**

DRAWN BY: JWJ DATE: 3-08
 CHECKED BY: TBQ DATE: 3-08

D-1809.40
 STV / Ralph Whitehead Associates, Inc.
 1000 West Morehead St., Ste. 200
 Charlotte, NC 28208

REVISIONS				SHEET NO.
NO.	BY:	DATE:	NO.	DATE:
1	STV	5-08	3	
2			4	

TOTAL SHEETS: 62

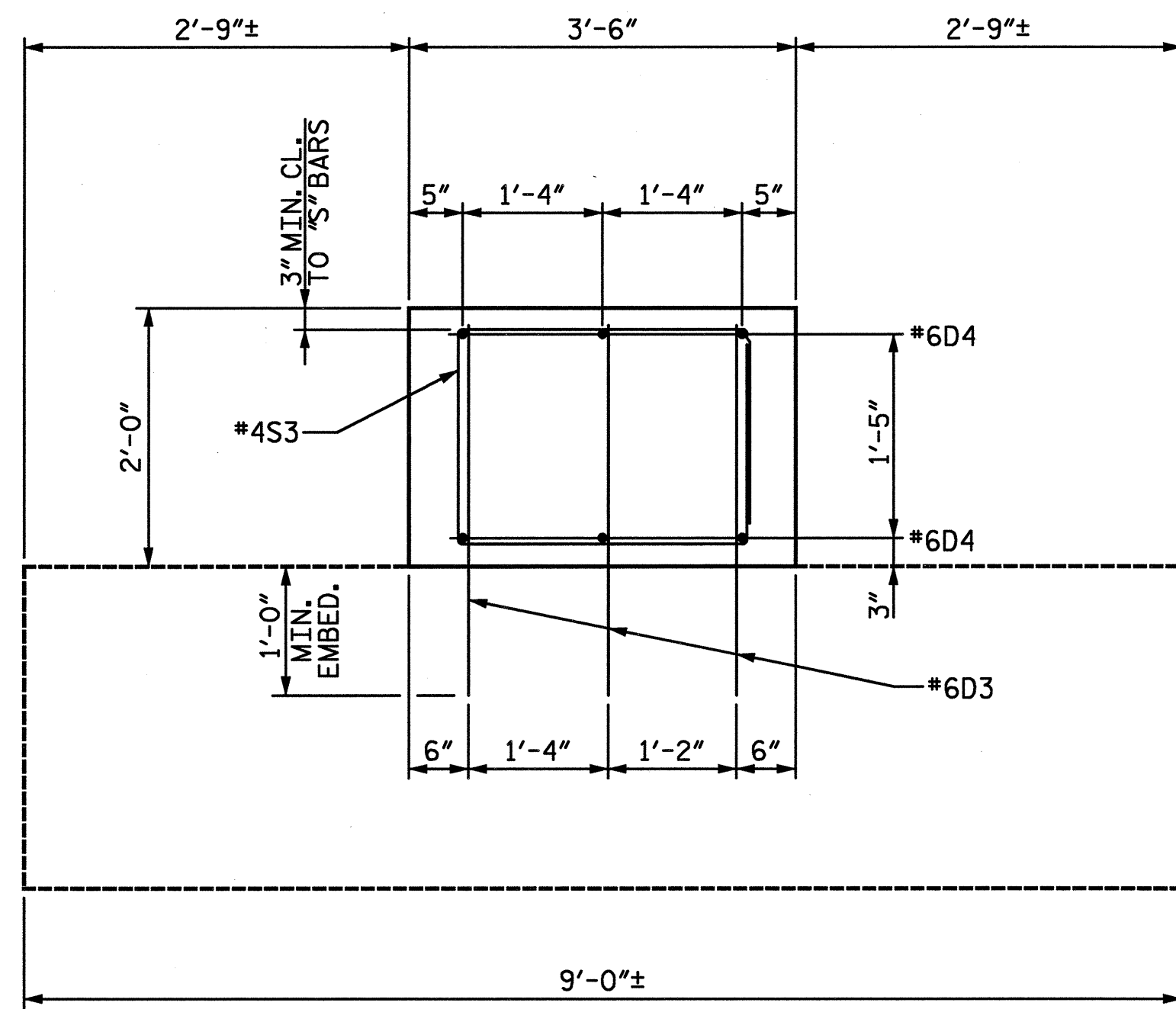

SECTION C-C

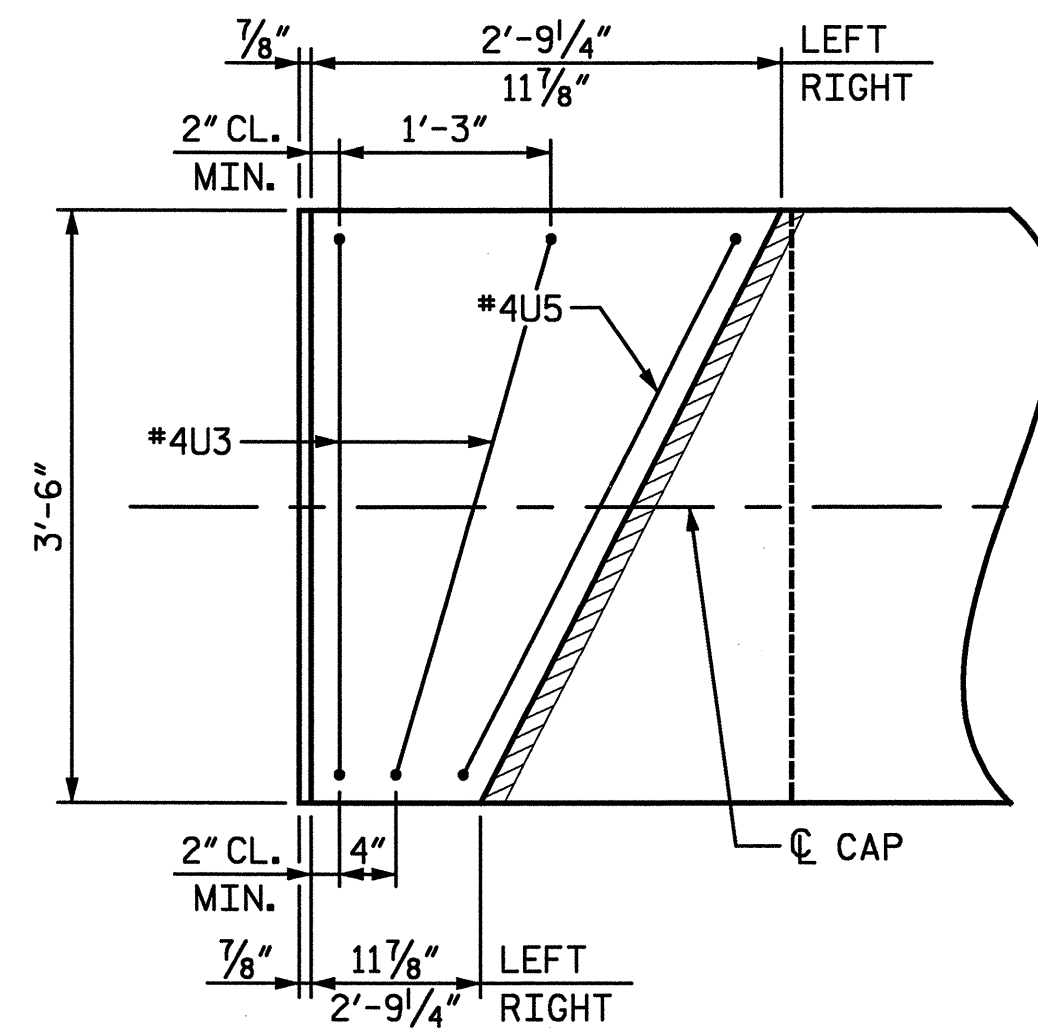

PLAN

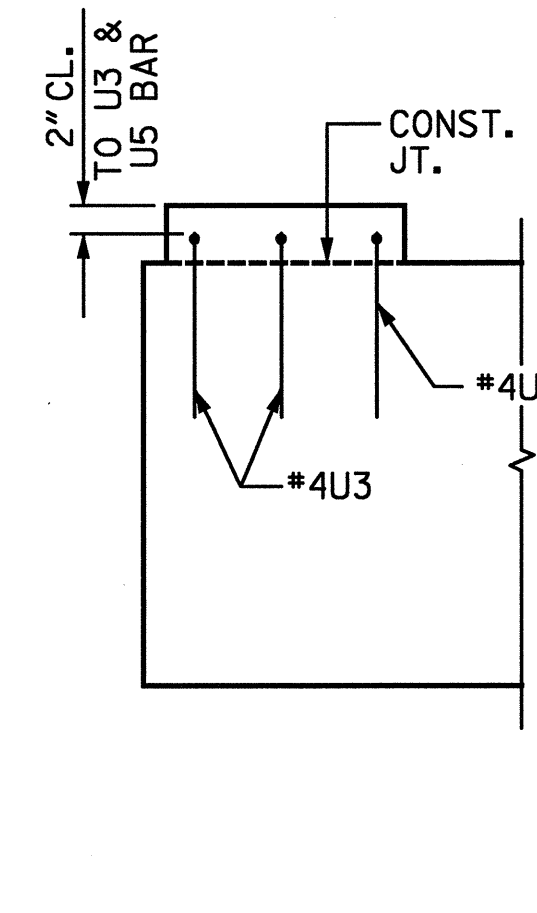

ELEVATION

LATERAL GUIDE DETAILS
(LEFT SIDE SHOWN, RIGHT SIDE SIMILAR)

BAR TYPES

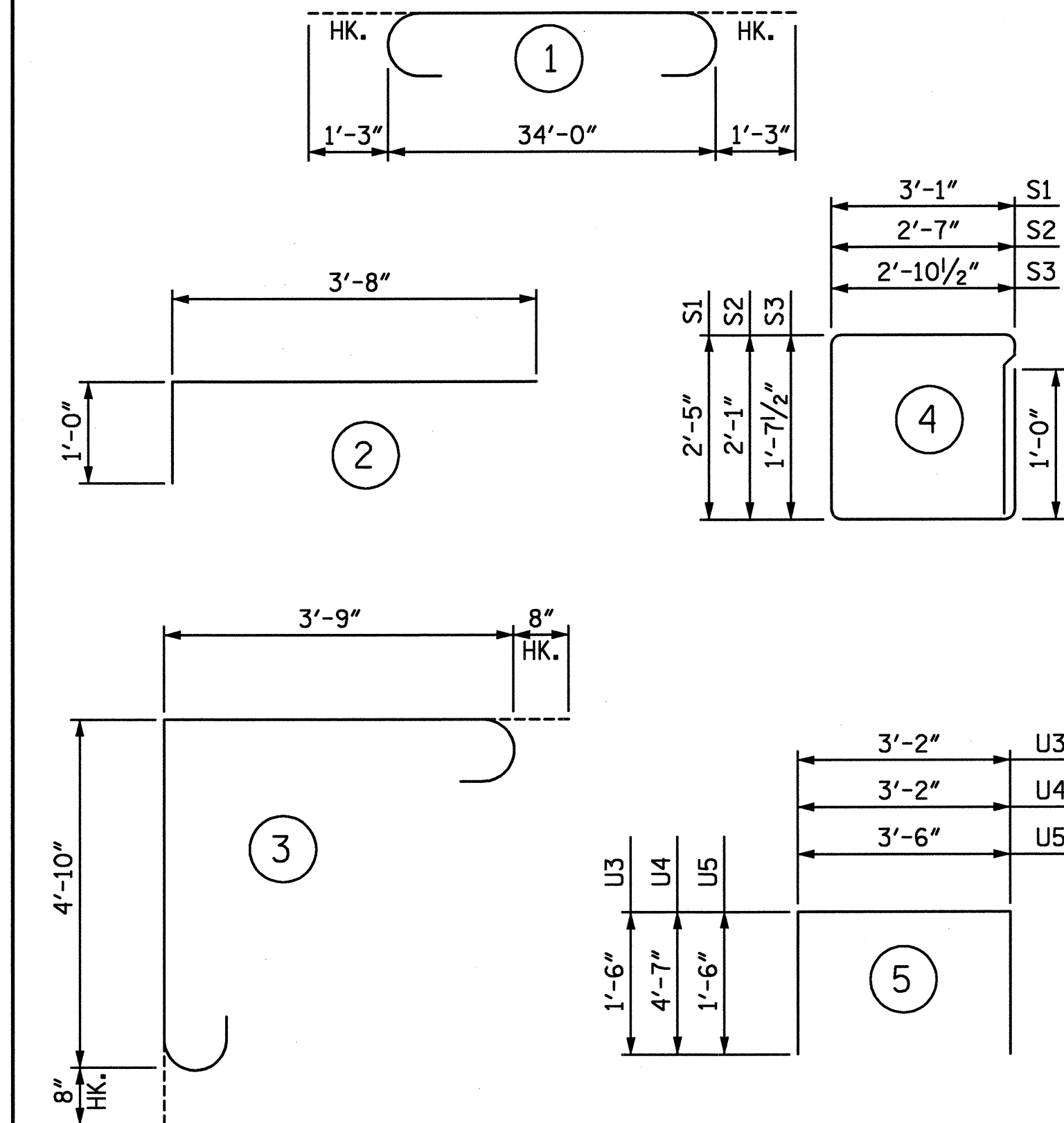

ALL BAR DIMENSIONS ARE OUT TO OUT.

BILL OF MATERIAL

BILL OF REINFORCING FOR ONE BENT (4 REQ'D.)

BAR NO.	NO.	SIZE	TYPE	LENGTH	WEIGHT
B1	4	9	①	36'-6"	496
B2	4	6	STR.	34'-0"	204
D1	36	6	STR.	1'-6"	81
D2	58	6	STR.	3'-7"	312
D3	36	6	STR.	2'-9"	149
D4	24	6	STR.	3'-0"	108
S1	34	4	④	12'-0"	273
S2	8	4	④	10'-4"	55
S3	12	4	④	10'-0"	80
U1	8	6	③	9'-11"	119
U2	20	6	②	4'-8"	140
U3	4	4	⑤	6'-2"	16
U4	8	4	⑤	12'-4"	66
U5	2	4	⑤	6'-6"	9

REINFORCING STEEL LBS. 2,108

CLASS AA CONCRETE BREAKDOWN

POUR 1 (CAP & FOOTING) CY 17.1
POUR 2 (LATERAL GUIDE) CY 0.3

TOTAL CY 17.4

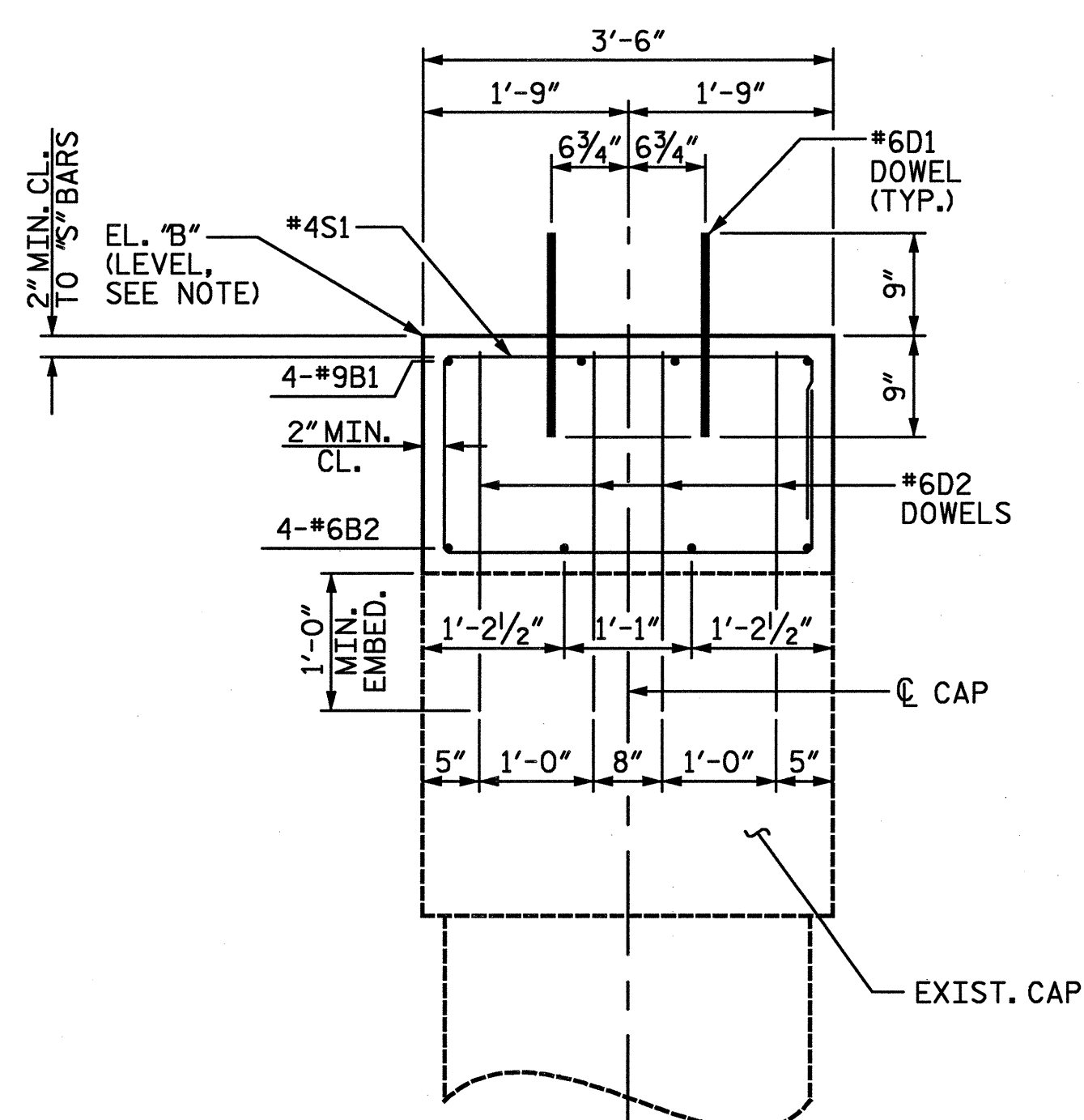

SECTION B-B

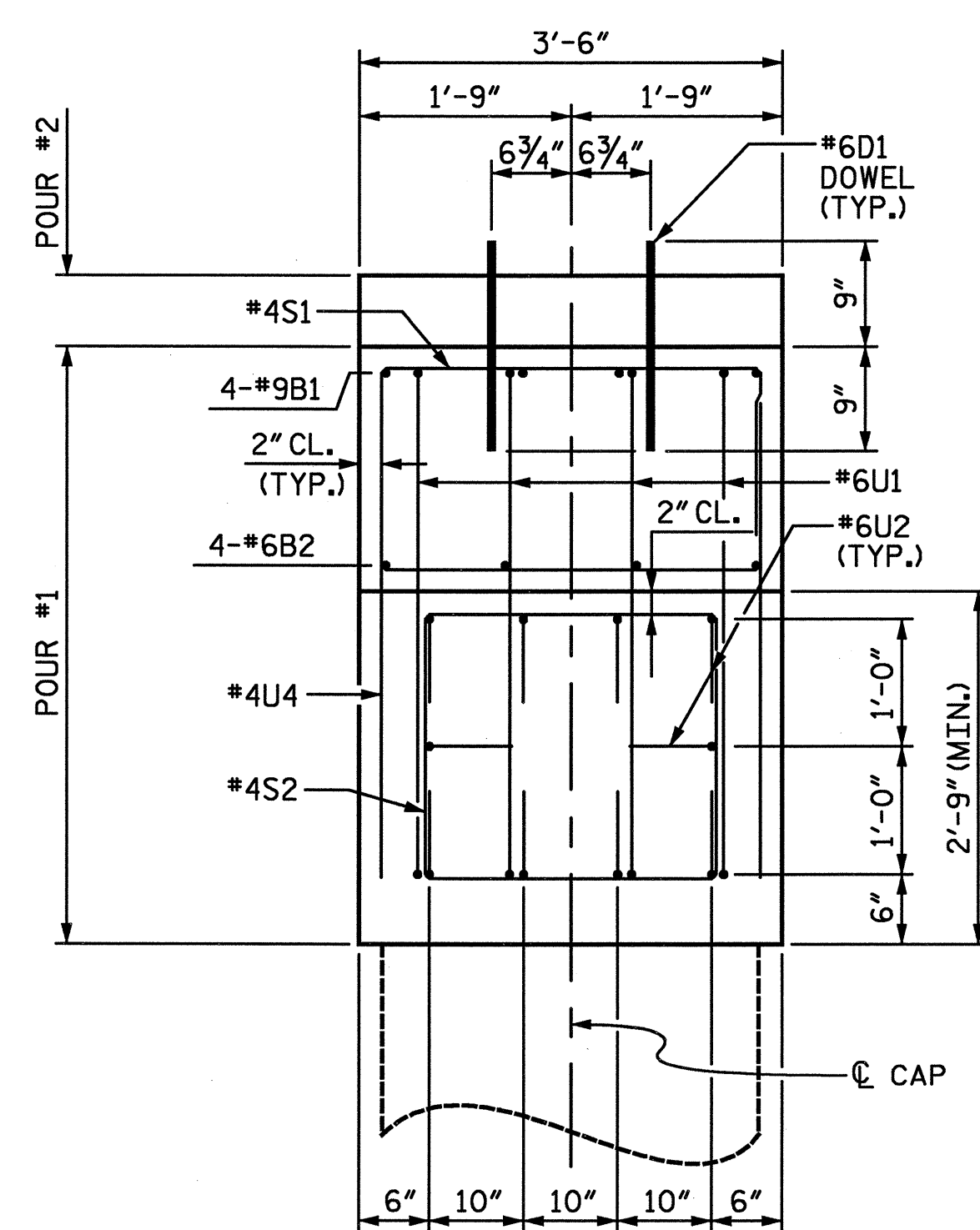

SECTION A-A

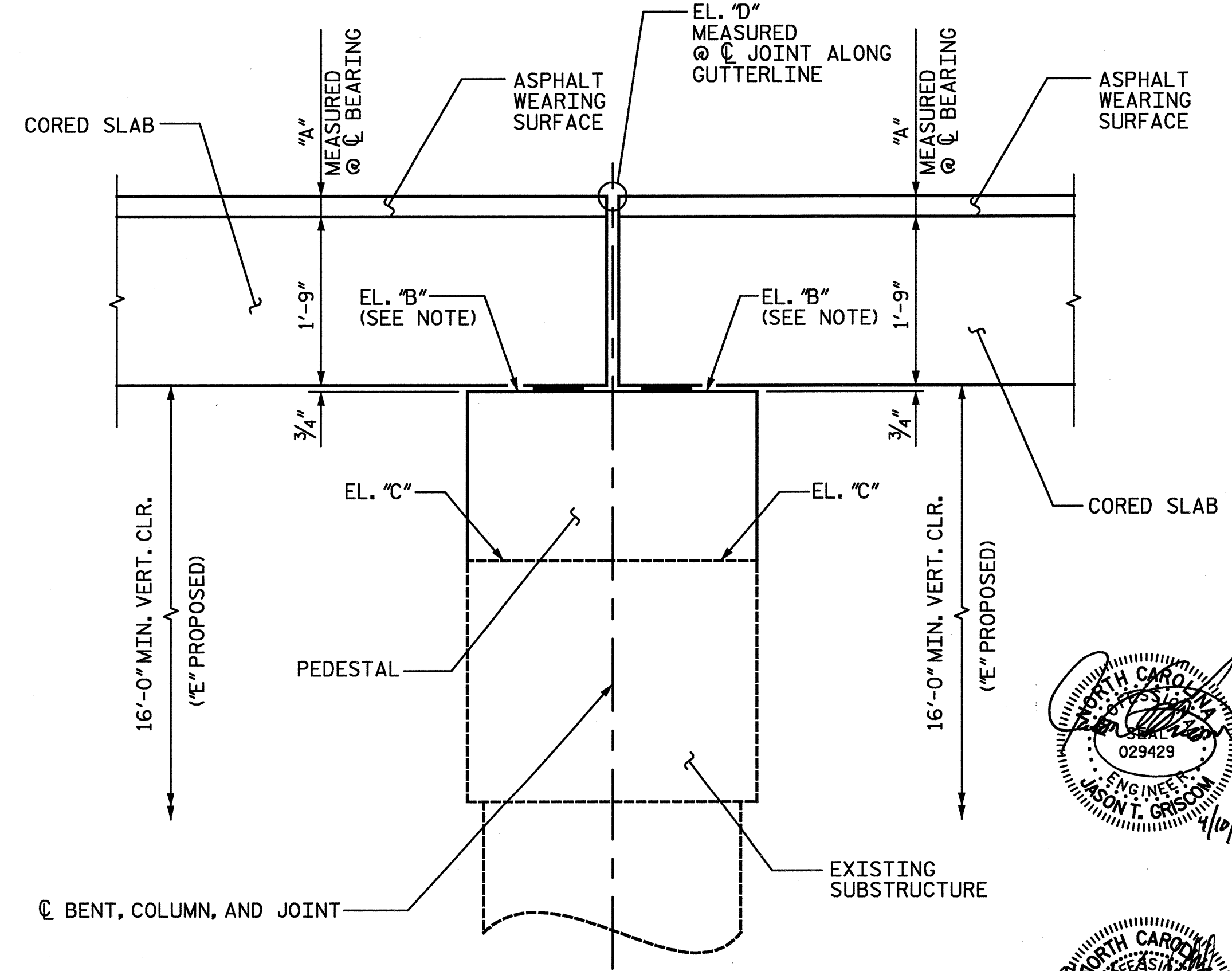

DOWNSTATION

UPSTATION

PEDESTAL HEIGHT

NOTE: DIMENSIONS AND ELEVATIONS SHOWN ARE FROM BEST INFORMATION AVAILABLE. CONTRACTOR SHALL MAKE ADJUSTMENTS TO PEDESTAL EL. 'B' TO MAINTAIN 3" (5/2" MAX.) SPANS A & E OR 3" (5" MAX.) SPANS B-D ASPHALT WEARING SURFACE @ CL. BEARING, MATCH EL. 'D', AND TO MAINTAIN THE 16'-0" MIN. VERTICAL CLEARANCE. IF ANY ELEVATIONS ARE MODIFIED, THE CONTRACTOR IS RESPONSIBLE FOR ADJUSTING THE REINFORCING TO FIT THE PEDESTAL HEIGHT.

	BENT 1	BENT 2	BENT 3	BENT 4
"A"	3"	3"	3"	3"
"B"	185.30	185.80	185.81	185.33
"C"	182.55	183.04	183.01	182.53
"D"	187.36	187.86	187.87	187.39
"E"	16'-10"	16'-10"	17'-4"	17'-4"

PROJECT NO. B-5021
ROBESON COUNTY
BRIDGE: 162

SHEET 2 OF 2

STATE OF NORTH CAROLINA
DEPARTMENT OF TRANSPORTATION
RALEIGH

SUBSTRUCTURE
BENTS 1-4

REVISIONS

NO.	BY:	DATE:	NO.	BY:	DATE:
1			3		
2			4		

SHEET NO. S-41
TOTAL SHEETS 62

DRAWN BY: JWJ DATE: 3-08
CHECKED BY: TBQ DATE: 3-08

D-1809.41

STV/Ralph Whitehead Associates, Inc.
1000 West Morehead St., Ste. 200
Charlotte, NC 28208

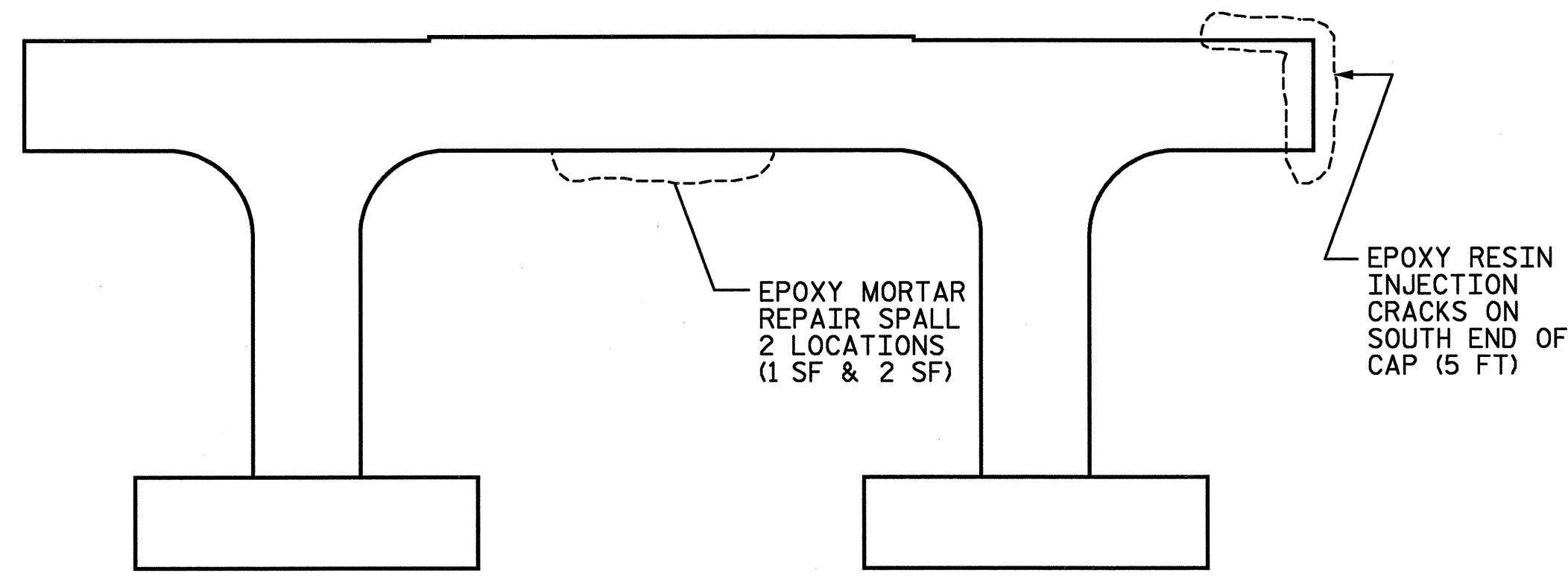

BENT 1 ELEVATION
(LOOKING SOUTHEAST)

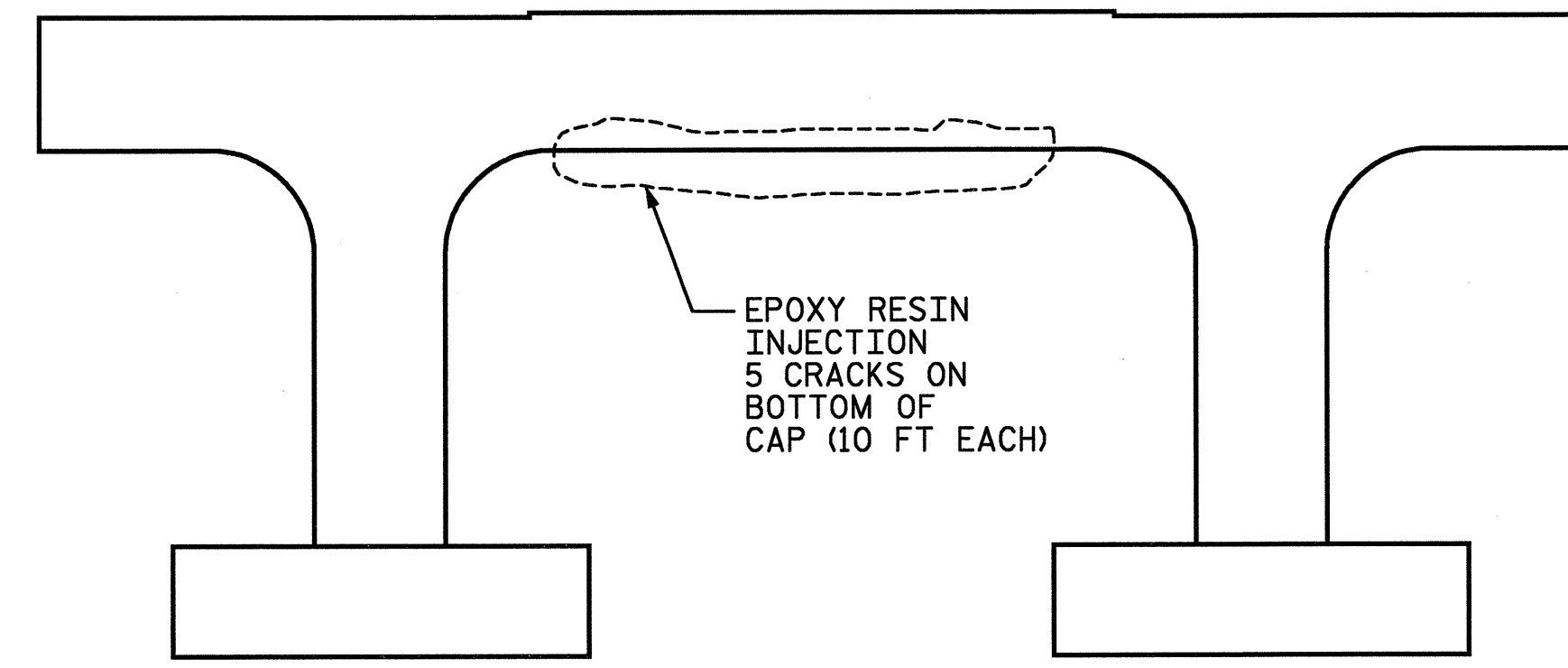

BENT 3 ELEVATION
(LOOKING SOUTHEAST)

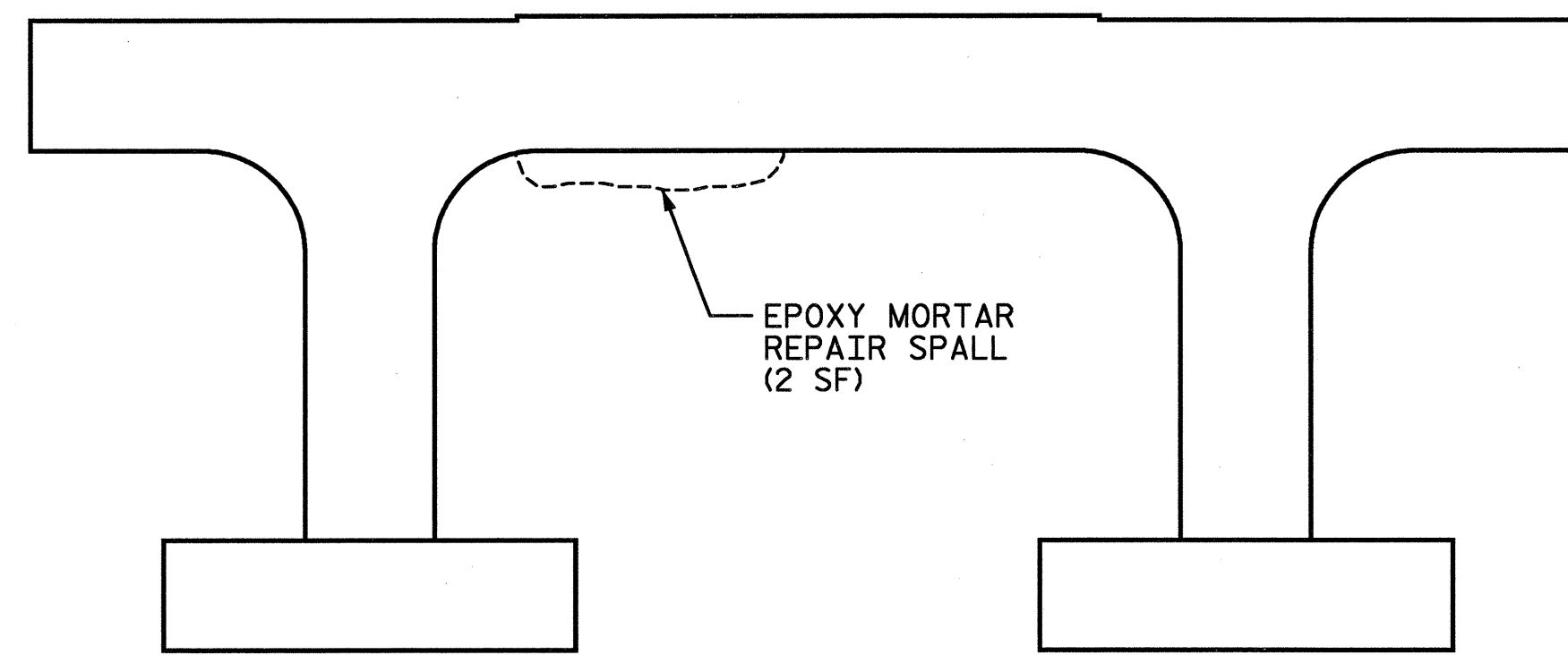

BENT 2 ELEVATION
(LOOKING SOUTHEAST)

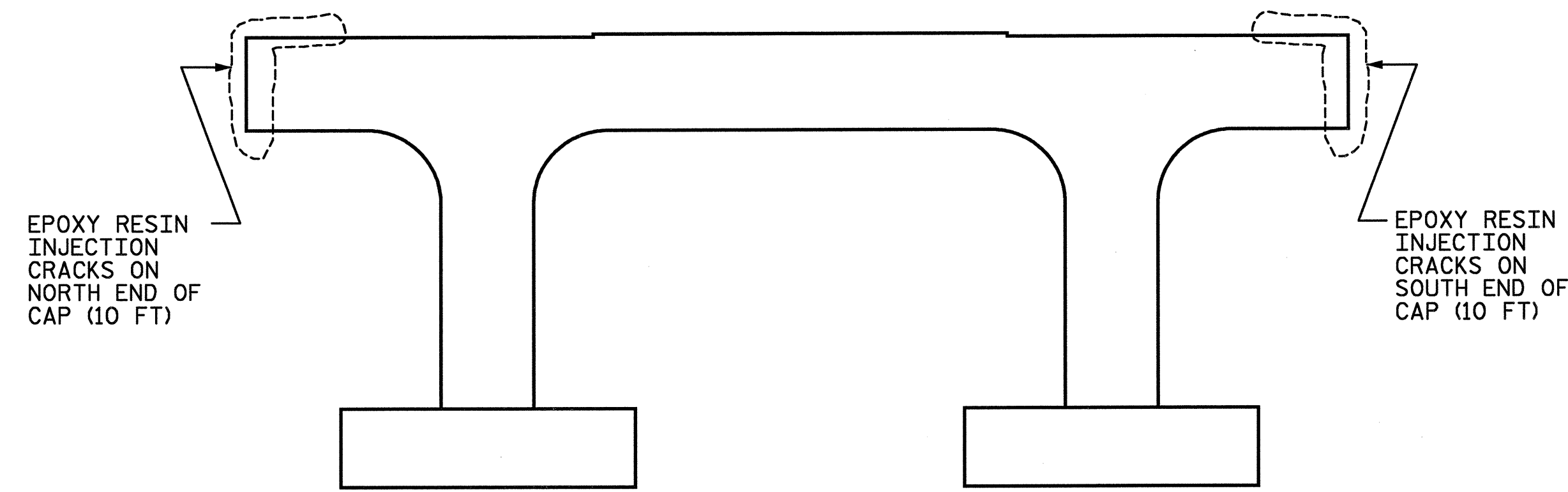

BENT 4 ELEVATION
(LOOKING SOUTHEAST)

- NOTES:**
- REPAIRS SHALL BE IMPLEMENTED DURING SUPERSTRUCTURE REPLACEMENT.
 - SAWCUT 1/4" - 1/2" DEEP AROUND ALL SPALLS.
 - FOR EPOXY RESIN INJECTION, SEE SPECIAL PROVISIONS.
 - FOR EPOXY MORTAR REPAIRS, SEE SPECIAL PROVISIONS.

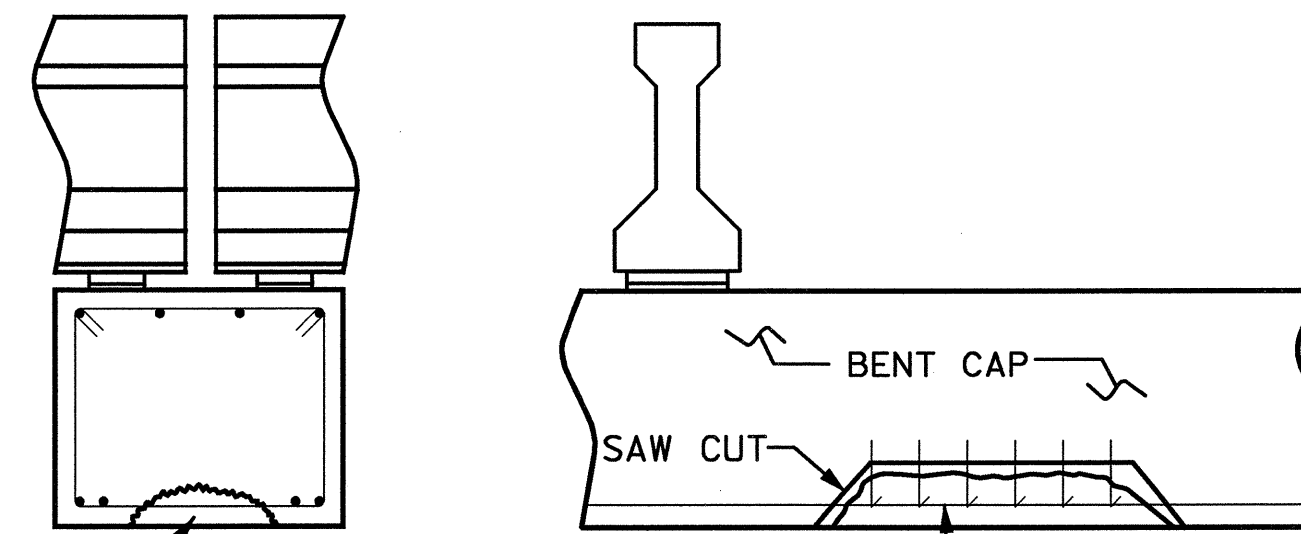

SECTION **ELEVATION**
TYPICAL BENT REPAIR DETAIL

PROJECT NO. B-5021
ROBESON COUNTY
 BRIDGE: 162

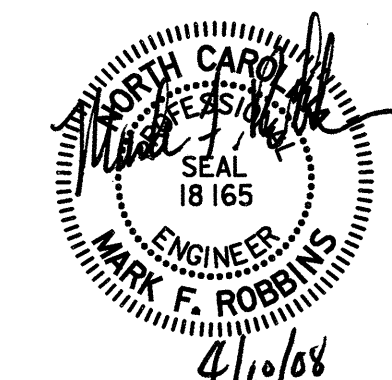
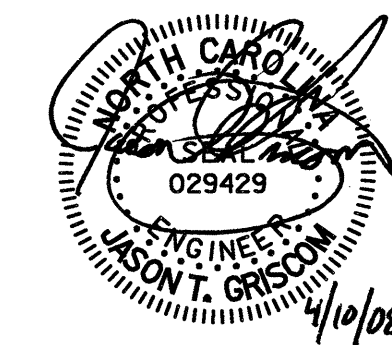

STATE OF NORTH CAROLINA
 DEPARTMENT OF TRANSPORTATION
 RALEIGH

**SUBSTRUCTURE
 REPAIRS**

REVISIONS						SHEET NO.
NO.	BY:	DATE:	NO.	BY:	DATE:	S-43
1			3			TOTAL SHEETS
2			4			62

D-1809.43
 STV/Ralph Whitehead Associates, Inc.
 1000 West Morehead St., Ste. 200
 Charlotte, NC 28208

N:\PROJ\2513448\B5021\Br\Idgs 162\Ustation\Finals\substructure repairs.dgn

11:03:31 AM

timothy.townsend 4/10/2008

DRAWN BY: JAD DATE: 3-08
 CHECKED BY: JTG DATE: 3-08

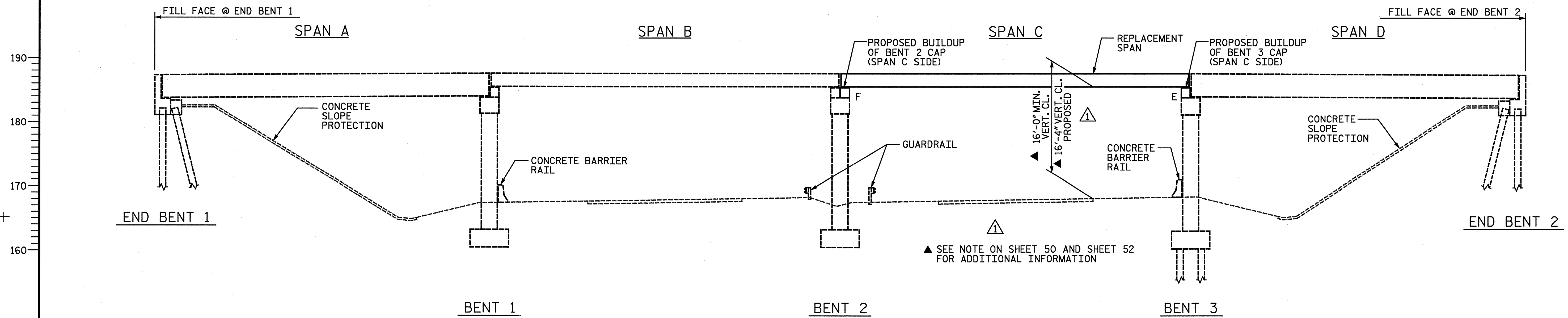

ELEVATION

SECTIONS AT BENTS AND END BENTS ARE AT RIGHT ANGLES

▲ SEE NOTE ON SHEET 50 AND SHEET 52 FOR ADDITIONAL INFORMATION

ALL DIMENSIONS IN THESE PLANS ARE BASED ON BEST AVAILABLE INFORMATION. THE CONTRACTOR SHALL VERIFY DIMENSIONS IN FIELD PRIOR TO CONSTRUCTION AND ANY FABRICATION. CONTRACTOR SHALL NOTIFY THE ENGINEER OF ANY DISCREPANCIES SUCH THAT NECESSARY ADJUSTMENTS BE MADE BY THE CONTRACTOR.

TOTAL LENGTH OF BRIDGE = 214'-11" ± (FILL FACE TO FILL FACE ALONG C SURVEY)

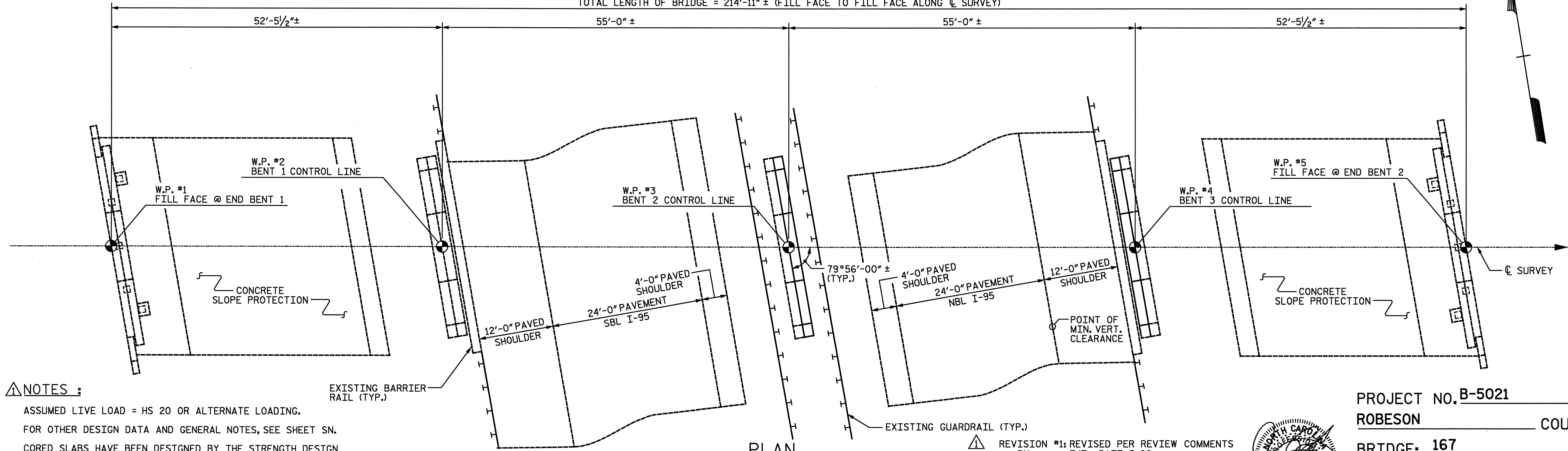

PLAN

PILES AND COLUMNS NOT SHOWN IN PLAN VIEW FOR CLARITY

- NOTES :**
- ASSUMED LIVE LOAD = HS 20 OR ALTERNATE LOADING.
 - FOR OTHER DESIGN DATA AND GENERAL NOTES, SEE SHEET SN.
 - CORED SLABS HAVE BEEN DESIGNED BY THE STRENGTH DESIGN METHOD AS SPECIFIED IN AASHTO STANDARD SPECIFICATIONS.
 - SPAN C OF THE EXISTING STRUCTURE CONSISTING OF 55'-0" PRESTRESSED CONCRETE GIRDERS, 24'-0" CLEAR ROADWAY WIDTH, REINFORCED CONCRETE DECK SHALL BE REMOVED. FOR PARTIAL REMOVAL OF EXISTING STRUCTURE, SEE SPECIAL PROVISIONS.
 - FOR PRESTRESSED CONCRETE MEMBERS, SEE SPECIAL PROVISIONS.
 - FOR SUBMITTAL OF WORKING DRAWINGS, SEE SPECIAL PROVISIONS.
 - FOR FALSEWORK AND FORMWORK, SEE SPECIAL PROVISIONS.
 - FOR CRANE SAFETY, SEE SPECIAL PROVISIONS.
 - FOR MAINTENANCE AND PROTECTION OF TRAFFIC BENEATH PROPOSED STRUCTURE, SEE SPECIAL PROVISIONS.

REVISION #1: REVISED PER REVIEW COMMENTS
 BY: TJT DATE: 5-08
 CH'KD BY: KGB DATE: 5-08

TOTAL BILL OF MATERIAL							
	PARTIAL REMOVAL OF EXISTING STRUCTURE	CLASS AA CONCRETE	REINFORCING STEEL	CONCRETE BRIDGE RAIL	ELASTOMERIC BEARINGS	3'-0" X 1'-9" PRESTRESSED CONCRETE CORED SLABS	EPOXY RESIN INJECTION
	LUMP SUM	CU. YDS.	LBS.	LIN. FT.	LUMP SUM	LIN. FT.	LIN. FT.
SUPERSTRUCTURE	LUMP SUM			109.75	LUMP SUM	493.88	
BENT 2		5.8	896				
BENT 3		4.4	797				80.0
TOTAL	LUMP SUM	10.2	1,693	109.75	LUMP SUM	493.88	80.0

PROJECT NO. B-5021
 ROBESON COUNTY
 BRIDGE: 167
 MODIFICATION OF BRIDGE NO. 167

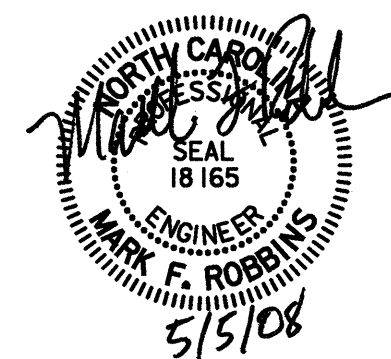
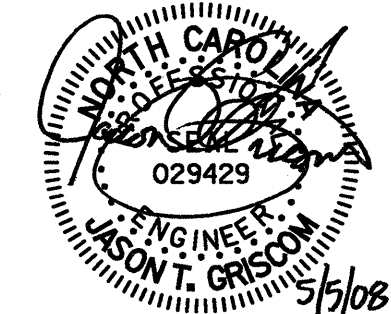

STATE OF NORTH CAROLINA
 DEPARTMENT OF TRANSPORTATION
 RALEIGH
**GENERAL DRAWING
 BRIDGE OVER I-95
 ON SR 1723**

DRAWN BY: LGH DATE: 2-08
 CHECKED BY: TBQ DATE: 3-08

D-1809.44
 STV / Ralph Whitehead Associates, Inc.
 1000 West Morehead St., Ste. 200
 Charlotte, NC 28208

REVISIONS						SHEET NO.
NO.	BY:	DATE:	NO.	BY:	DATE:	
1	STV	5-08	3			5-44
2			4			TOTAL SHEETS 62

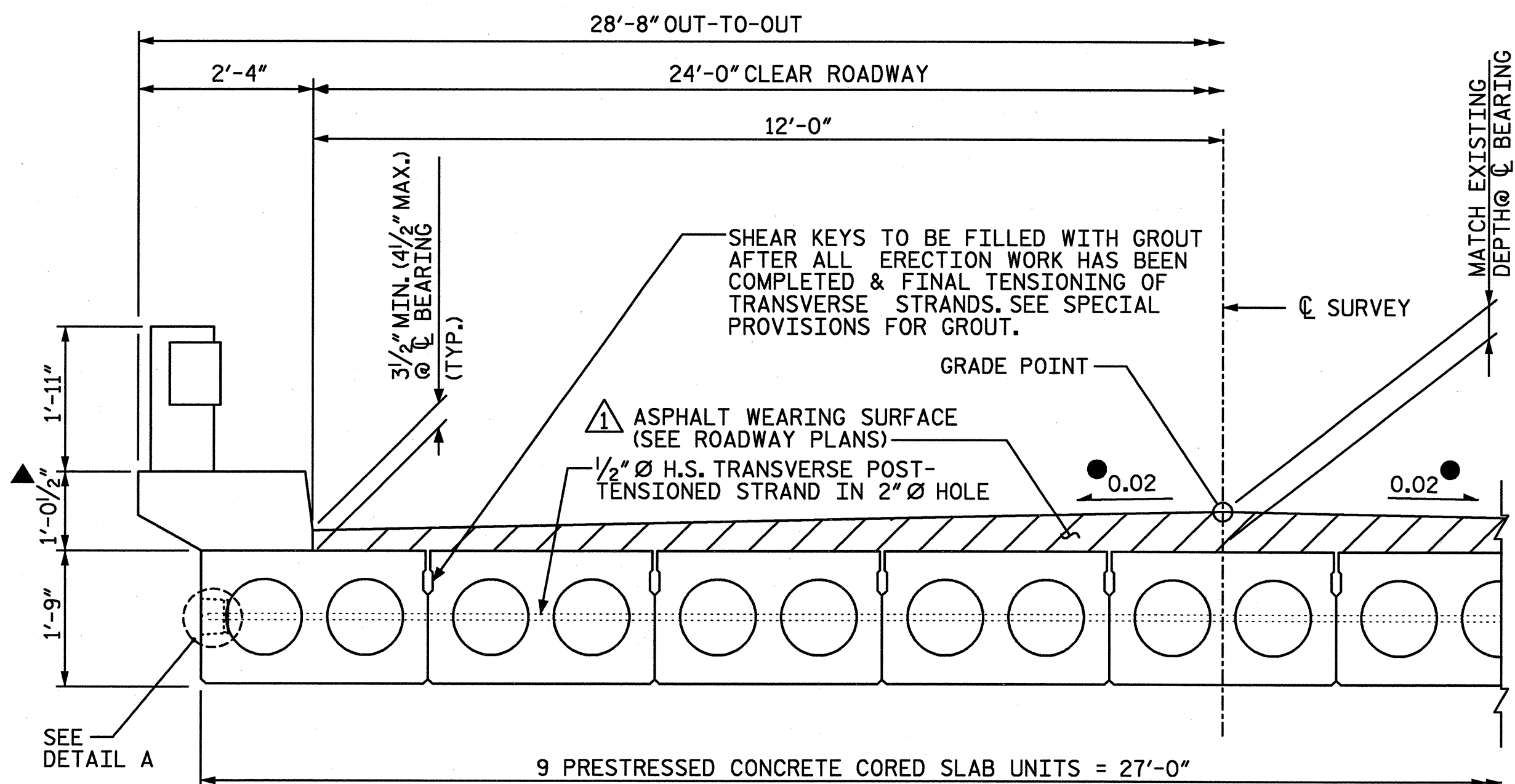

TYPICAL HALF SECTION
(BRIDGE SYMMETRIC ABOUT \bar{C} SURVEY)

▲ CURB HEIGHT MAY NEED TO BE ADJUSTED TO MATCH TOP OF CURB IN ADJACENT SPAN. REINFORCING SHALL BE ADJUSTED TO MATCH THE REVISED CURB HEIGHT.

● CONTRACTOR SHALL MAKE A SMOOTH TRANSITION TO MATCH EXISTING CROSS SLOPE ON ROADWAY APPROACHES.

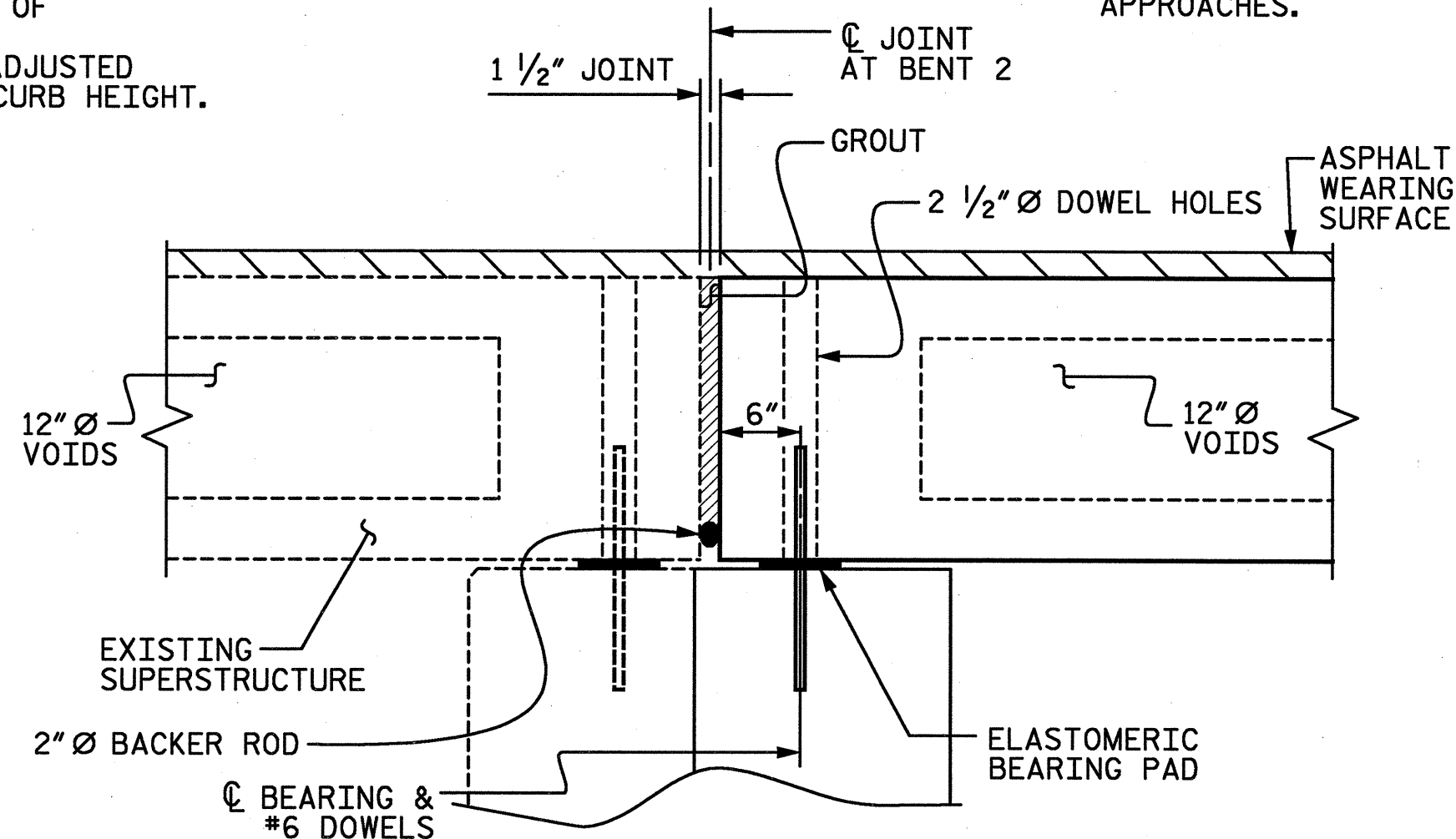

SECTION AT BENT 2

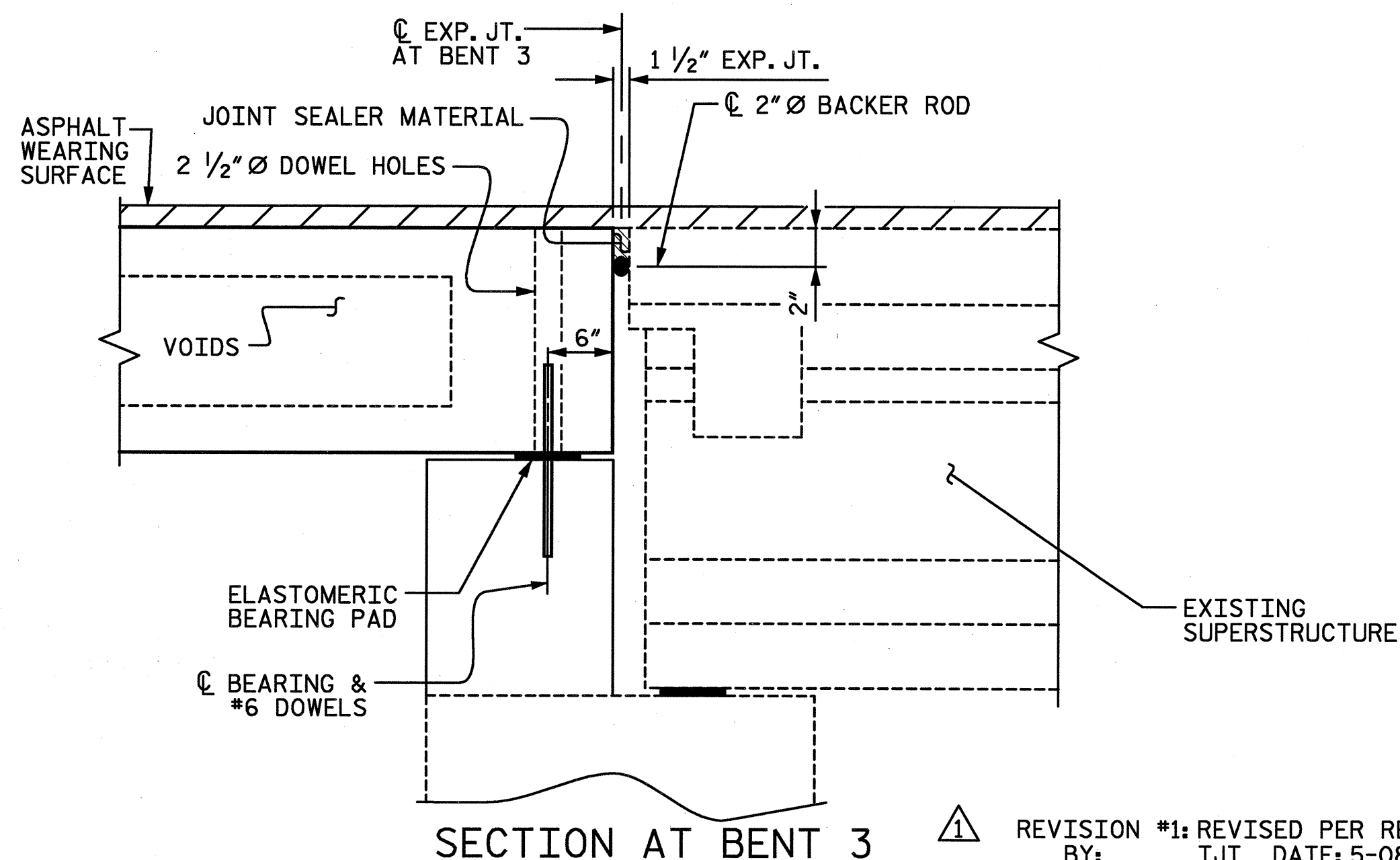

SECTION AT BENT 3

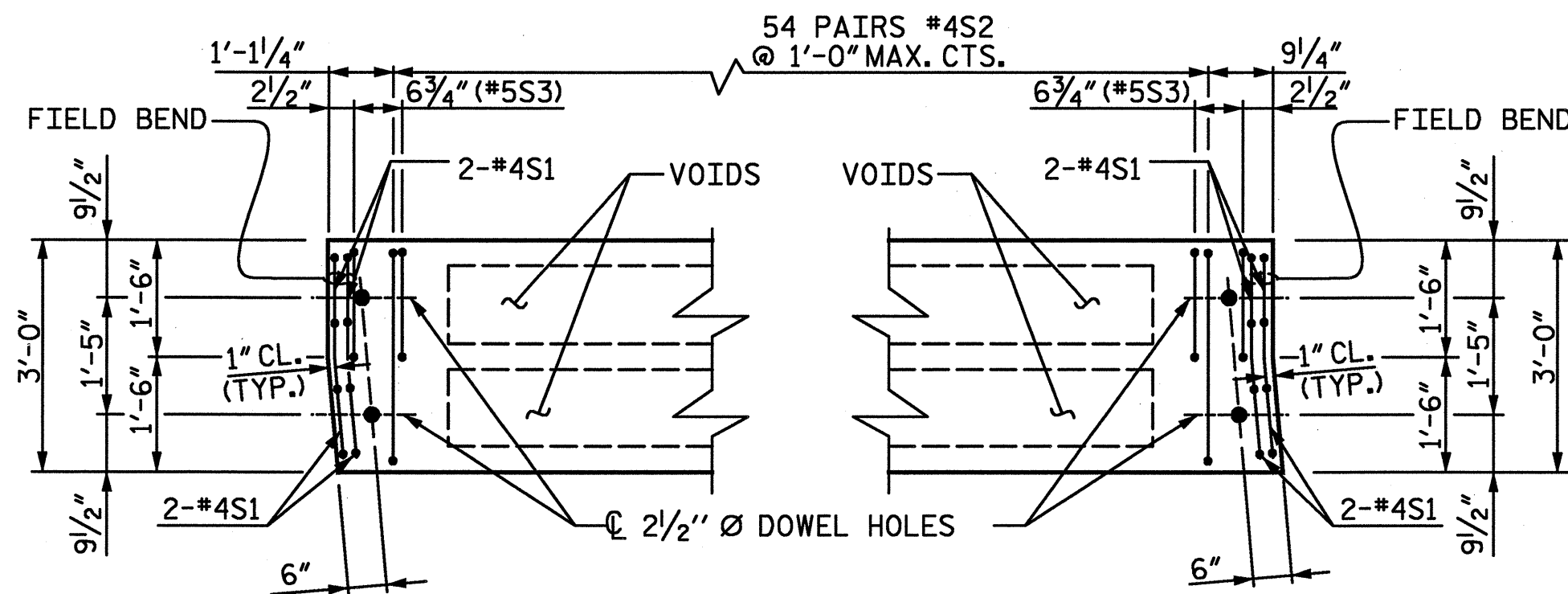

PART PLAN EXTERIOR SLAB SECTION

(LEFT SIDE SHOWN, RIGHT SIDE SIMILAR BY SYMMETRY)

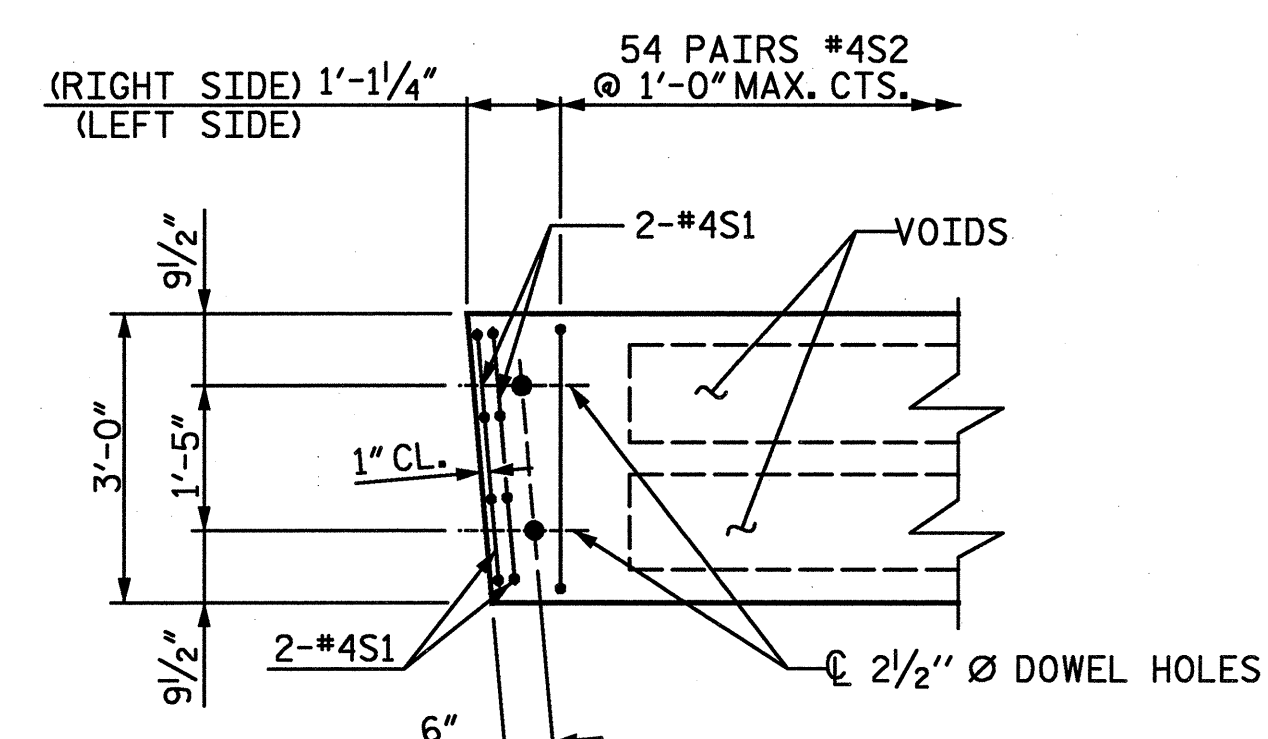

PART PLAN INTERIOR SLAB SECTION

(FAR END SHOWN, NEAR END SIMILAR BY SYMMETRY)

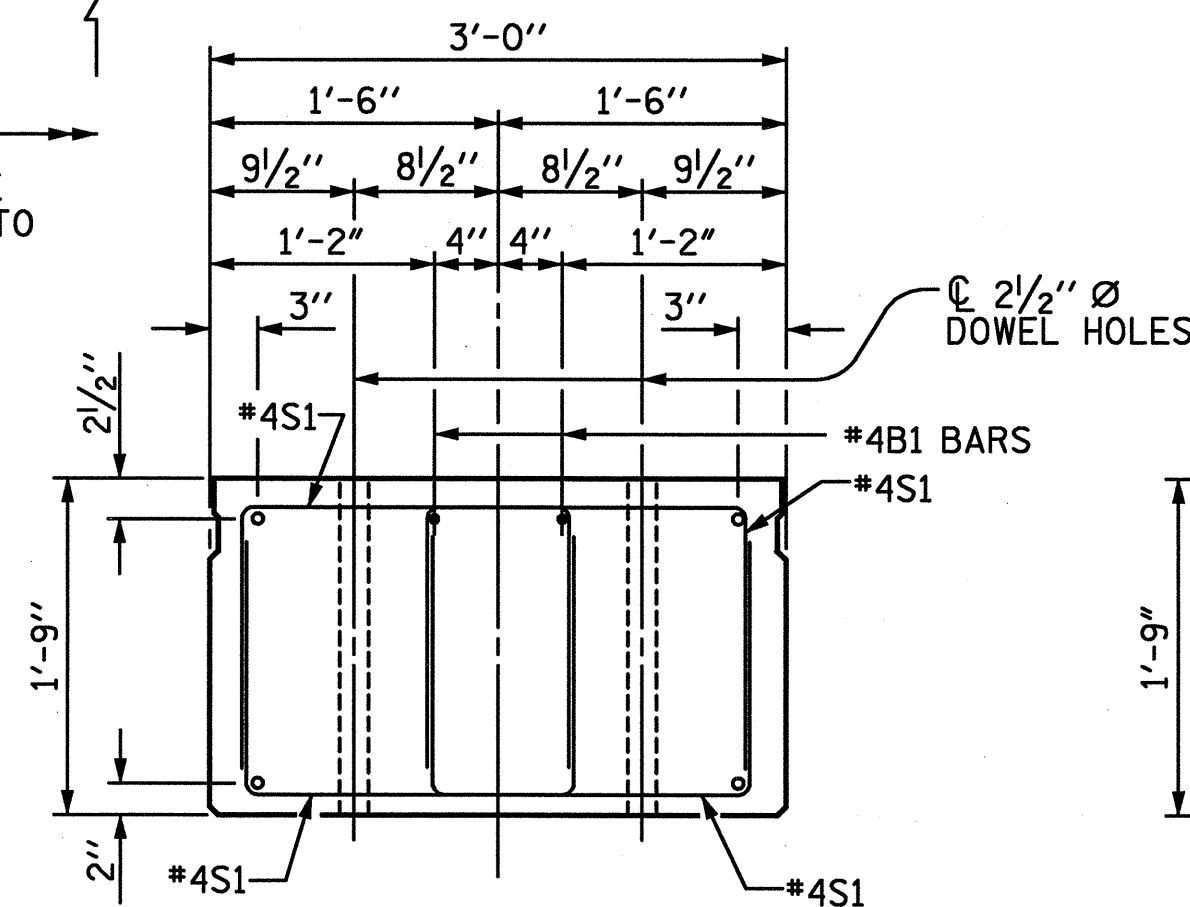

SLAB END ELEVATION

SHOWING PLACEMENT OF DOUBLE STIRRUPS AND LOCATION OF DOWEL HOLES.

INTERIOR SLAB SECTION SHOWN, EXTERIOR SLAB SECTION SIMILAR EXCEPT SHEAR KEY LOCATION.

STRAND LAYOUT NOT SHOWN.

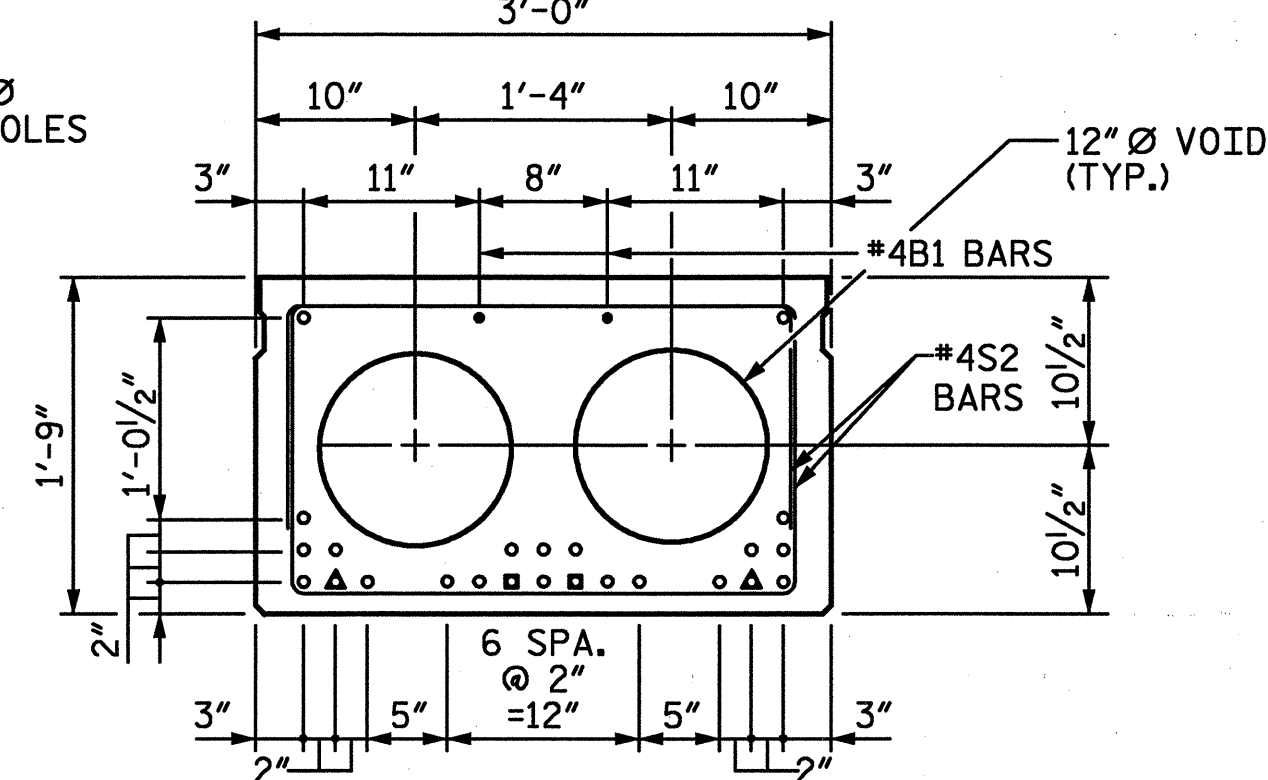

INTERIOR SLAB SECTION

(24 TOTAL STRANDS REQUIRED)

○ DENOTES 1/2" \bar{C} L.R. STRANDS

▲ DENOTES SHEATHED STRAND. BOND SHALL BE BROKEN ON THESE STRANDS FOR A DISTANCE OF 4'-0" FROM END OF SLAB.

■ DENOTES SHEATHED STRAND. BOND SHALL BE BROKEN ON THESE STRANDS FOR A DISTANCE OF 6'-0" FROM END OF SLAB.

SEE STANDARD SPECIFICATIONS ARTICLE 1078-7.

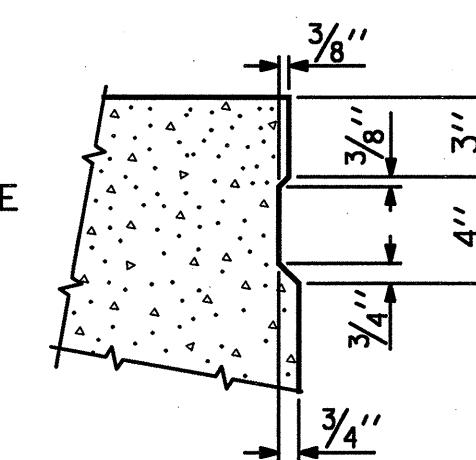

SHEAR KEY DETAIL

NOTE: OMIT SHEAR KEY ON OUTSIDE FACE OF EXTERIOR CORED SLAB

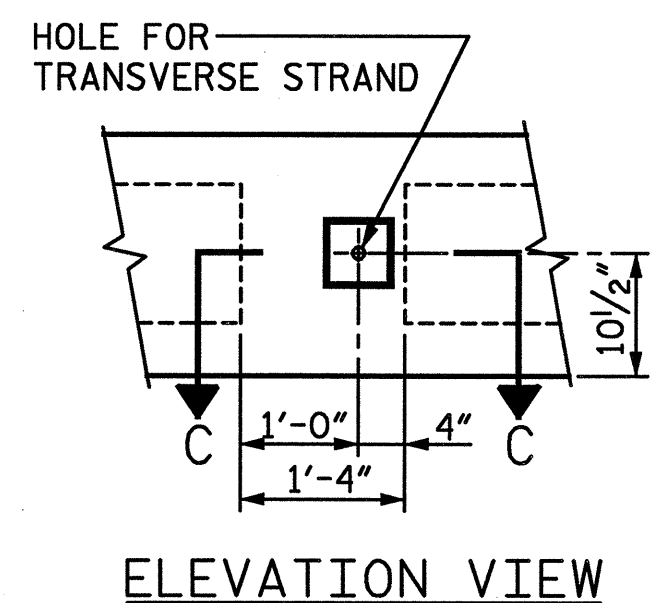

ELEVATION VIEW

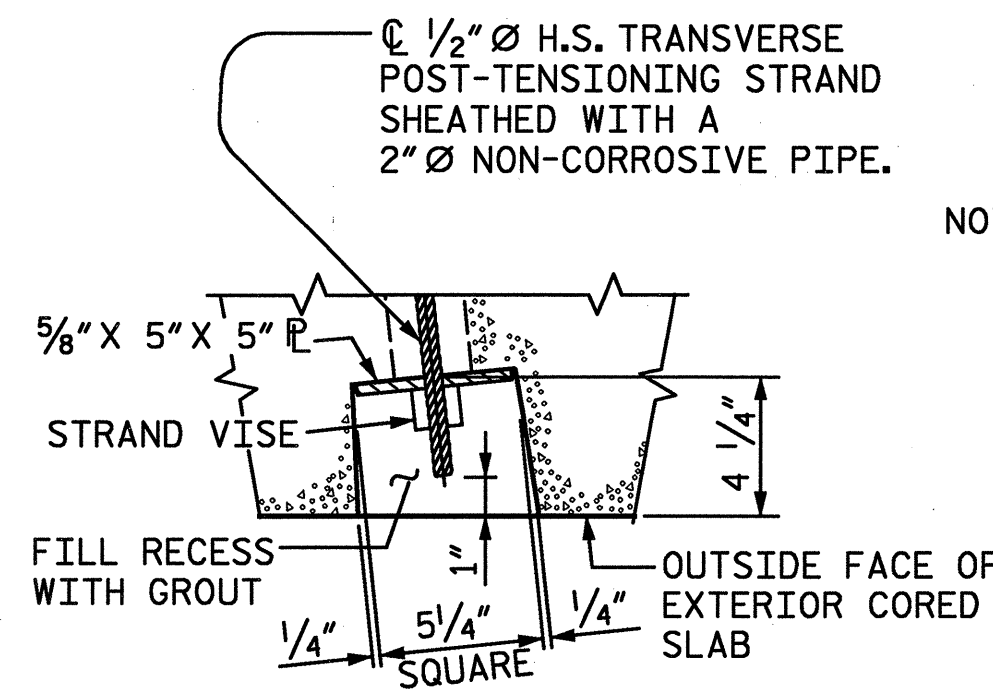

SECTION C-C

DETAIL A

GROUTED RECESS AT END OF POST-TENSIONED STRAND CORED SLABS

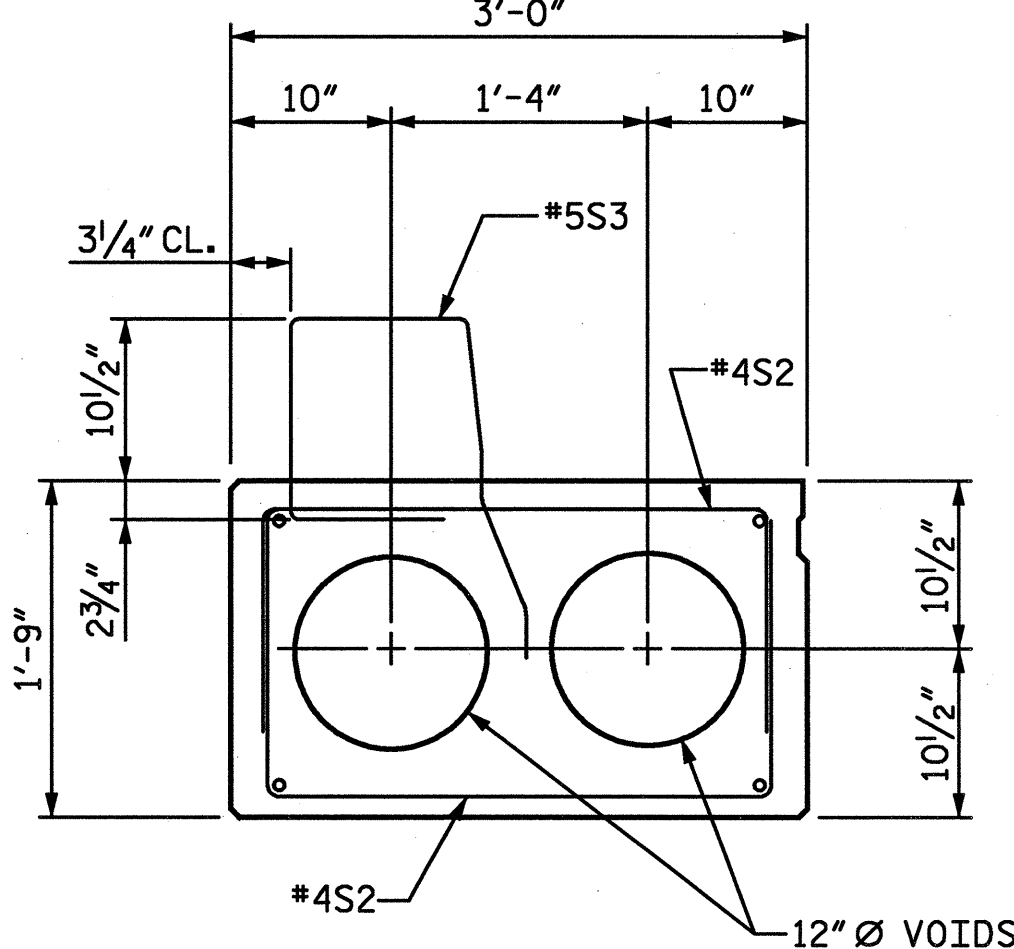

EXTERIOR SLAB SECTION

(FOR PRESTRESSED STRAND AND #4B1 BAR LAYOUT, SEE INTERIOR SLAB SECTION)

PROJECT NO. B-5021

ROBESON COUNTY

BRIDGE: 167

SHEET 1 OF 4

STATE OF NORTH CAROLINA
DEPARTMENT OF TRANSPORTATION
RALEIGH

3'-0" X 1'-9"
PRESTRESSED
CORED SLAB

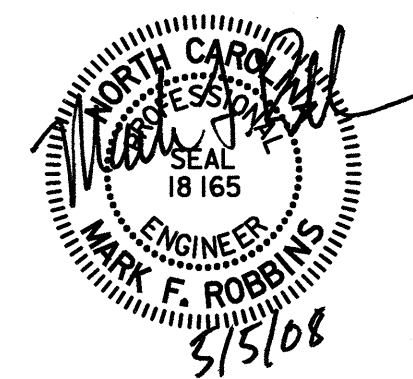
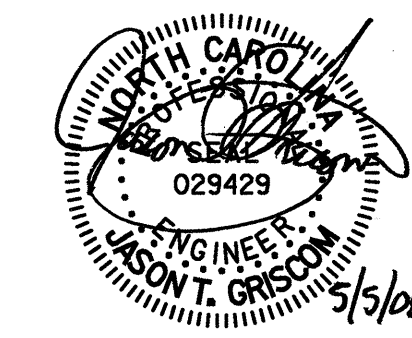

D-1809.45

STV / Ralph Whitehead Associates, Inc.
1000 West Morehead St., Ste. 200
Charlotte, NC 28208

REVISIONS

NO.	BY:	DATE:	NO.	BY:	DATE:
1	STV	5-08	3		
2			4		

SHEET NO.
5-45
TOTAL SHEETS
62

DRAWN BY: LGH DATE: 2-08
CHECKED BY: TBQ DATE: 2-08

REVISION #1: REVISED PER REVIEW COMMENTS
BY: TJT DATE: 5-08
CH'KD BY: KGB DATE: 5-08

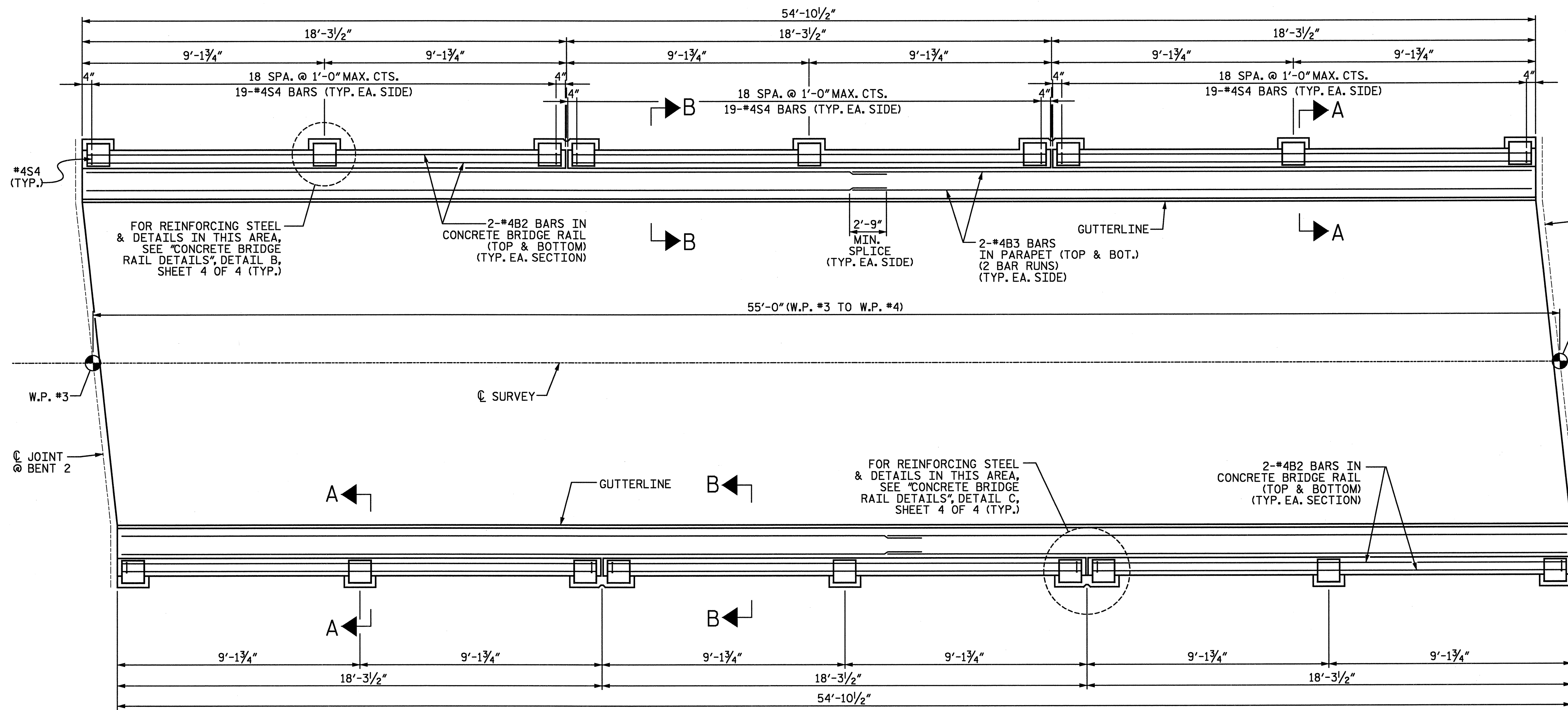

NOTE:
FOR SECTION VIEWS, SEE SHEET 4 OF 4.
CONCRETE BRIDGE RAIL SHALL BE CHAMFERED TO MATCH EXISTING RAIL. FOR CONCRETE BRIDGE RAIL, SEE SPECIAL PROVISIONS.

PLAN

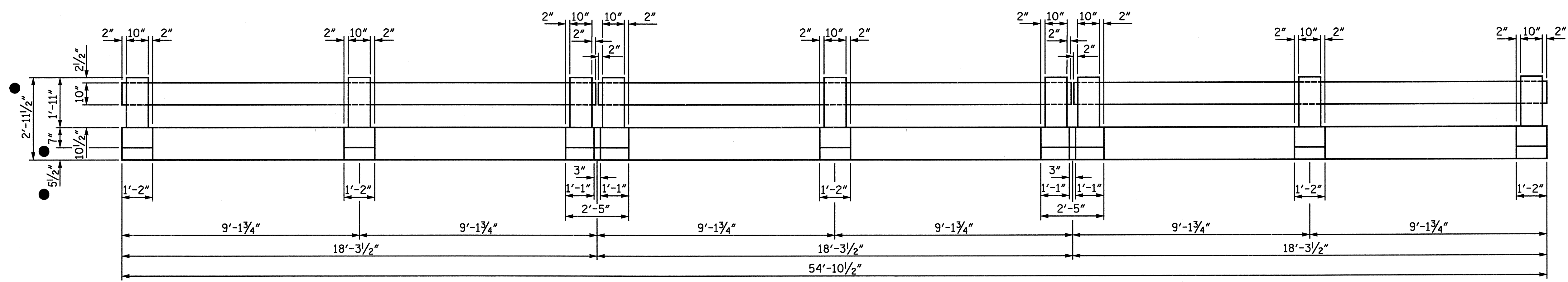

ELEVATION

(EXTERIOR OF RIGHT SIDE RAIL SHOWN, LEFT SIDE SIMILAR)

● DIMENSION MAY NEED TO BE ADJUSTED TO MATCH TOP OF RAIL IN ADJACENT SPANS. REINFORCING SHALL BE ADJUSTED TO MATCH THE REVISED RAIL HEIGHT.

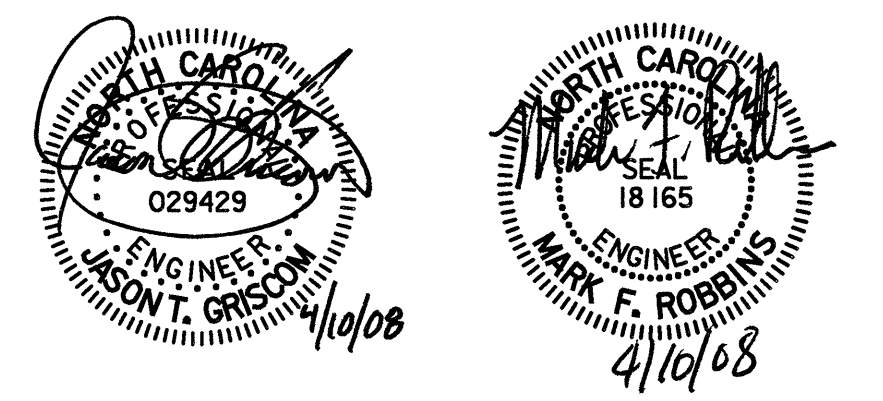

PROJECT NO. B-5021
ROBESON COUNTY
BRIDGE: 167
SHEET 3 OF 4

STATE OF NORTH CAROLINA DEPARTMENT OF TRANSPORTATION RALEIGH					
SUPERSTRUCTURE CONCRETE BRIDGE RAIL					
REVISIONS					
NO.	BY:	DATE:	NO.	BY:	DATE:
1			3		
2			4		
					SHEET NO. 5-47
					TOTAL SHEETS 62

DRAWN BY: TRL DATE: 1-08
CHECKED BY: TBQ DATE: 3-08

D-1809.47
STV / Ralph Whitehead Associates, Inc.
1000 West Morehead St., Ste. 200
Charlotte, NC 28208

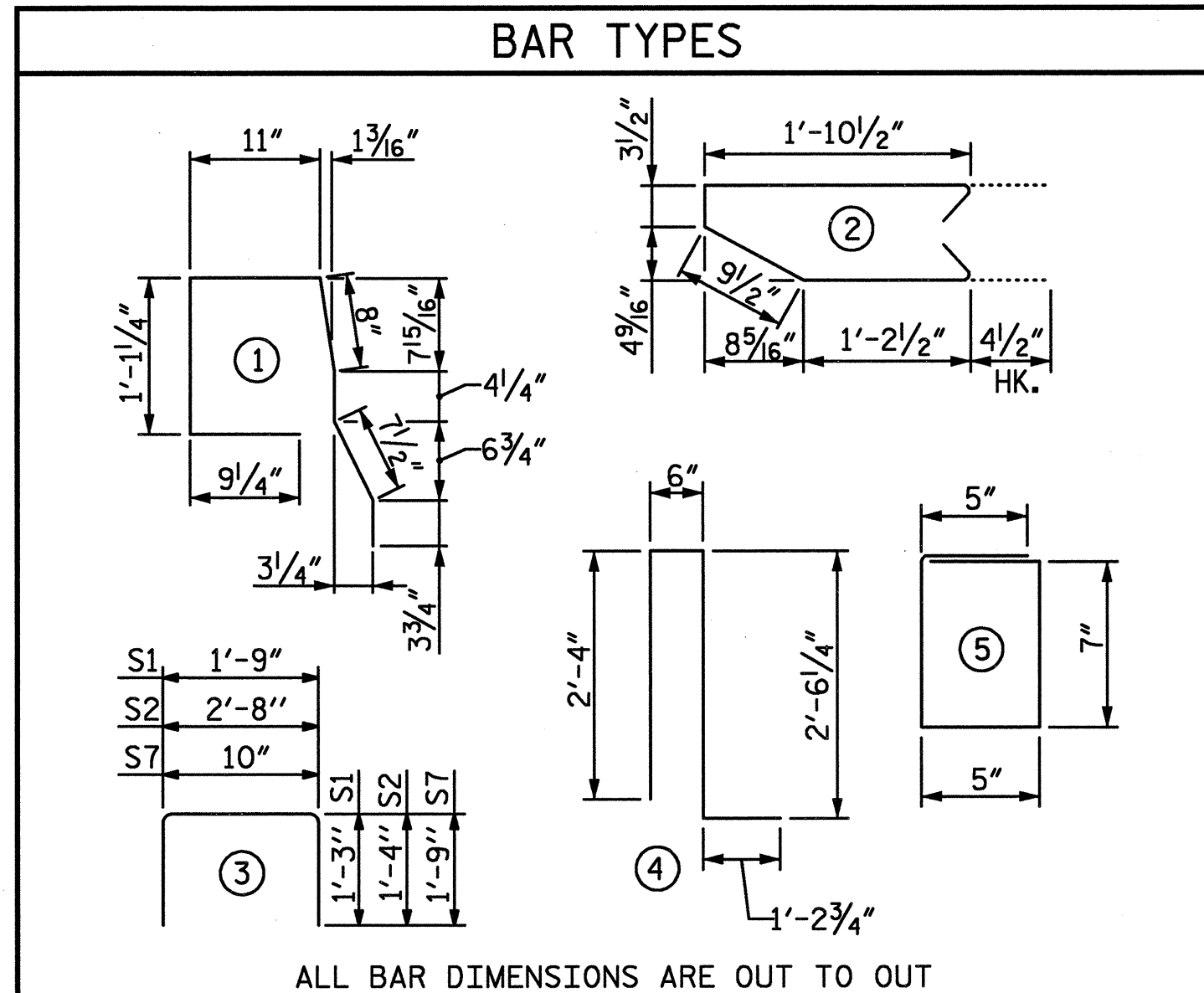
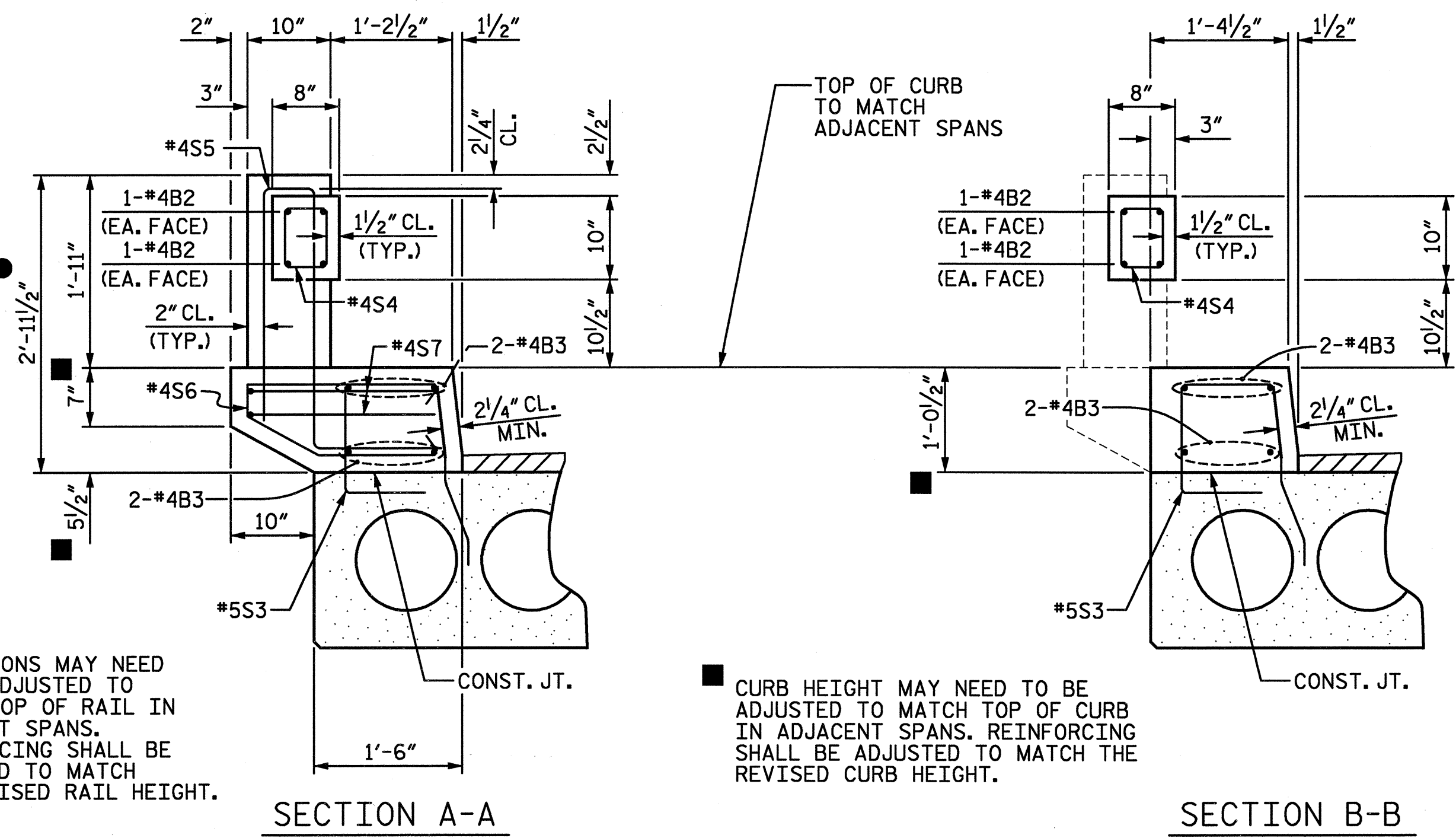

BILL OF MATERIAL FOR ONE CORED SLAB SECTION

BAR	NUMBER	SIZE	TYPE	EXTERIOR UNIT LENGTH	EXTERIOR UNIT WEIGHT	INTERIOR UNIT LENGTH	INTERIOR UNIT WEIGHT
B1	4	#4	STR	28'-1"	75	28'-1"	75
S1	16	#4	3	4'-3"	45	4'-3"	45
S2	108	#4	3	5'-4"	385	5'-4"	385
*S3	56	#5	1	4'-9"	277		
REINFORCING STEEL					505 LBS.		505 LBS.
*EPOXY COATED REINFORCING STEEL					277 LBS.		
6000 P.S.I. CONCRETE					7.7 CY		7.7 CY
1/2" Ø L.R. STRANDS				No.	24		24

DEAD LOAD DEFLECTION AND CAMBER

CAMBER (SLAB ALONE IN PLACE)	1/8"
DEFLECTION DUE TO SUPERIMPOSED DEAD LOAD**	3/8"
FINAL CAMBER	1/2"

** INCLUDES FUTURE WEARING SURFACE

BILL OF MATERIAL FOR CONCRETE BRIDGE RAIL AND PARAPET

BAR	TOTAL NO.	SIZE	TYPE	LENGTH	WEIGHT
*B2	24	#4	STR	17'-10"	286
*B3	16	#4	STR	28'-8"	306
*S4	114	#4	5	2'-5"	184
*S5	36	#4	4	6'-7"	158
*S6	36	#4	2	4'-11"	118
*S7	36	#4	3	4'-4"	104
*EPOXY COATED REINFORCING STEEL					1,156 LBS.
CLASS AA CONCRETE					9.8 CY
TOTAL LIN. FT. OF CONCRETE BARRIER RAIL					109'-9"

CORED SLABS REQUIRED

	NUMBER	LENGTH	TOTAL LENGTH
EXTERIOR C.S.	2	54'-10 1/2"	109'-9"
INTERIOR C.S.	7	54'-10 1/2"	384'-1 1/2"
TOTAL	9		493'-10 1/2"

GRADE 270 STRANDS

	1/2" Ø L.R.
AREA (SQUARE INCHES)	0.153
ULTIMATE STRENGTH (LBS. PER STRAND)	41,300
APPLIED PRESTRESS (LBS. PER STRAND)	30,980

NOTES

ALL PRESTRESSING STRANDS SHALL BE 7-WIRE LOW RELAXATION GRADE 270 STRANDS AND SHALL CONFORM TO AASHTO M203 EXCEPT FOR SAMPLING REQUIREMENTS WHICH SHALL BE IN ACCORDANCE WITH THE STANDARD SPECIFICATIONS.

ALL REINFORCING STEEL CAST WITH THE CORED SLAB SECTIONS SHALL BE GRADE 60 AND SHALL BE INCLUDED IN THE UNIT PRICE BID FOR PRESTRESSED CONCRETE CORED SLABS.

RECESSES FOR TRANSVERSE STRANDS SHALL BE GROUTED AFTER THE TENSIONING OF THE STRANDS.

THE 2 1/2" Ø DOWEL HOLES AT FIXED ENDS OF SLAB SECTIONS SHALL BE FILLED WITH GROUT. THE 2 1/2" Ø DOWEL HOLES AT EXPANSION ENDS OF SLAB SECTIONS SHALL BE FILLED WITH JOINT SEALER MATERIAL TO 1/2" ABOVE THE TOP OF DOWELS AND THEN FILLED WITH GROUT.

THE JOINT SEALER MATERIAL SHALL CONFORM TO THE REQUIREMENTS OF TYPE SL LOW MODULUS SILICONE SEALANT. THE 2" Ø BACKER ROD SHALL CONFORM TO THE REQUIREMENTS OF TYPE M BOND BREAKER. SEE SECTION 1028 OF THE STANDARD SPECIFICATIONS. PAYMENT FOR JOINT SEALER MATERIAL SHALL BE CONSIDERED INCIDENTAL TO CONSTRUCTION OF THE BRIDGE.

WHEN CORED SLABS ARE CAST, A POSITIVE HOLD-DOWN SYSTEM SHALL BE EMPLOYED TO PREVENT VOIDS FROM RISING OR MOVING SIDEWAYS. THIS SYSTEM SHALL BE DESIGNED TO BE LEFT IN PLACE UNTIL THE CONCRETE HAS REACHED RELEASE STRENGTH. AT LEAST THREE WEEKS PRIOR TO CASTING CORED SLABS, THE CONTRACTOR SHALL SUBMIT TO THE ENGINEER FOR REVIEW AND COMMENT, DETAILED DRAWINGS OF THE PROPOSED HOLD-DOWN SYSTEM. IN ADDITION TO STRUCTURAL DETAILS, LOCATION AND SPACING OF THE HOLD-DOWNS SHALL BE INDICATED.

THE TRANSFER OF LOAD FROM THE ANCHORAGES TO THE CORED SLAB UNIT SHALL BE DONE WHEN THE CONCRETE HAS REACHED A COMPRESSIVE STRENGTH OF NOT LESS THAN 4800 PSI.

ALL REINFORCING STEEL IN BARRIER RAILS SHALL BE EPOXY COATED. PRESTRESSING STRANDS SHALL BE CUT FLUSH WITH THE CORED SLAB UNIT ENDS.

APPLY EPOXY PROTECTIVE COATING TO CORED SLAB UNIT ENDS.

VERTICAL GROOVED CONTRACTION JOINTS, 1/2" IN DEPTH, SHALL BE TOOLED IN ALL EXPOSED FACES OF THE BRIDGE RAIL AND IN ACCORDANCE WITH ARTICLE 825-10(B) OF THE STANDARD SPECIFICATIONS. THE CONTRACTION JOINTS SHALL BE LOCATED AT A SPACING OF 8 FEET TO 10 FEET BETWEEN EXPANSION JOINTS AND NO CONTRACTION JOINTS ARE REQUIRED FOR THOSE SEGMENTS LESS THAN 10 FEET IN LENGTH.

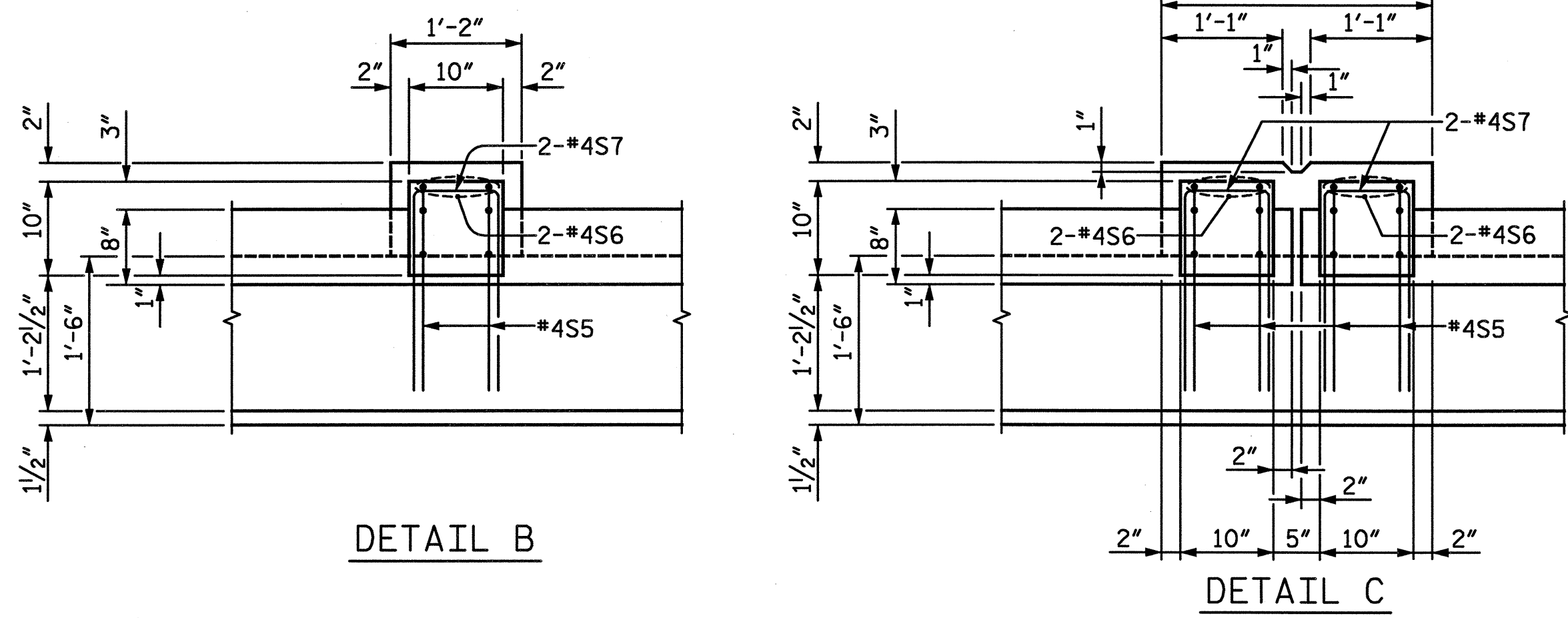

CONCRETE BRIDGE RAIL DETAILS

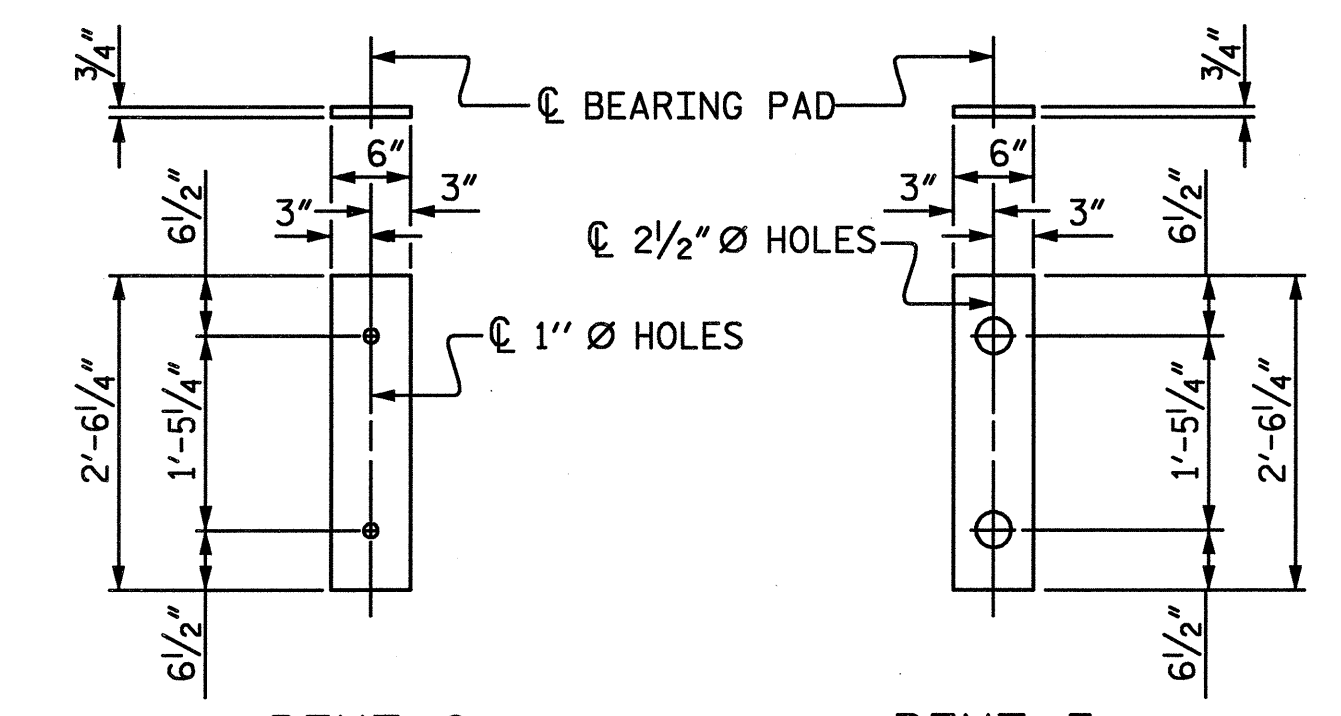

ELASTOMERIC BEARING DETAILS

SUPERSTRUCTURE REINFORCING STEEL LENGTHS ARE BASED ON THE FOLLOWING MINIMUM SPLICE LENGTHS

BAR SIZE	SUPERSTRUCTURE EXCEPT APPROACH SLABS, PARAPET AND BARRIER RAIL		APPROACH SLABS		PARAPET AND BARRIER RAIL
	EPOXY COATED	UNCOATED	EPOXY COATED	UNCOATED	
#4	2'-0"	1'-9"	2'-0"	1'-9"	2'-9"
#5	2'-6"	2'-2"	2'-6"	2'-2"	3'-5"
#6	3'-0"	2'-7"	3'-10"	2'-7"	4'-4"
#7	5'-3"	3'-6"			
#8	6'-10"	4'-7"			

PROJECT NO. **B-5021**

ROBESON COUNTY

BRIDGE: **167**

SHEET 4 OF 4

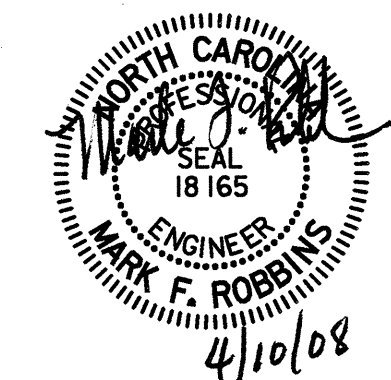
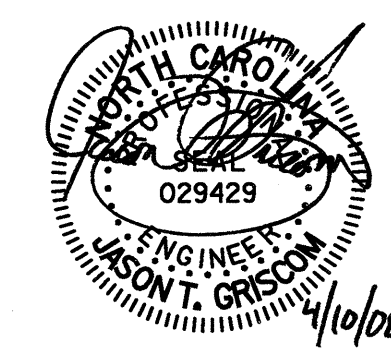

STATE OF NORTH CAROLINA
DEPARTMENT OF TRANSPORTATION
RALEIGH

SUPERSTRUCTURE CONCRETE BRIDGE RAIL DETAILS

REVISIONS

NO.	BY:	DATE:	NO.	BY:	DATE:
1			3		
2			4		

SHEET NO. S-48
TOTAL SHEETS 62

DRAWN BY: **TRL** DATE: **1-08**
CHECKED BY: **TBQ** DATE: **3-08**

D-1809.48
STV/ Ralph Whitehead Associates, Inc.
1000 West Morehead St., Ste. 200
Charlotte, NC 28208

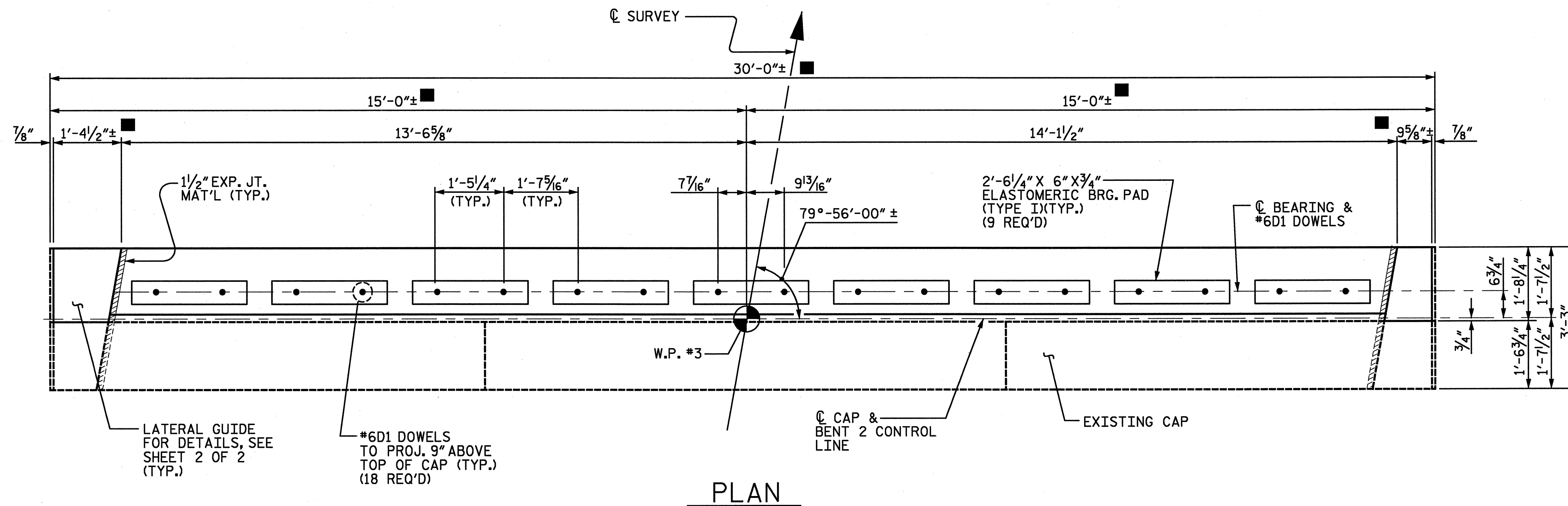

PLAN

NOTES

- REINFORCING STEEL MAY BE SHIFTED AS NECESSARY TO CLEAR DOWELS.
- THE LATERAL GUIDES ARE NOT TO BE POURED UNTIL AFTER THE CORED SLAB UNITS ARE IN PLACE.
- ALL ELEVATIONS ARE TO BE VERIFIED BY THE ENGINEER.
- A HIGH EARLY STRENGTH PORTLAND CEMENT CONCRETE SHALL BE USED TO ACHIEVE A MINIMUM COMPRESSIVE STRENGTH OF 5000 PSI PRIOR TO PLACING CORED SLAB UNITS. SEE STANDARD SPECIFICATION SECTION 1000 FOR DETAILS.
- *6D2, *6D3, AND *6D4 DOWELS SHALL BE ADHESIVELY ANCHORED USING AN APPROVED ADHESIVE CONSIDERING LOAD RESISTANCE, IN-SERVICE AND INSTALLATION TEMPERATURE, AVAILABILITY OF COMPREHENSIVE INSTALLATION INSTRUCTIONS, AND CREEP. ANCHORS SHALL BE INSTALLED TO THE MINIMUM EMBEDMENT DEPTHS AS SHOWN ON PLANS. LEVEL ONE FIELD TESTING IS REQUIRED, AND THE YIELD LOAD OF THE DOWEL IS 26 KIPS. FOR ADHESIVELY ANCHORED DOWELS, SEE SPECIAL PROVISIONS.
- DIMENSIONS AND ELEVATIONS ARE BASED ON AS-BUILT DIMENSIONS AND FIELD SURVEY INFORMATION. CONTRACTOR SHALL FIELD VERIFY DIMENSIONS PRIOR TO CONSTRUCTION. REINFORCING AND CONCRETE CAP EXTENSIONS SHALL BE ADJUSTED TO MATCH FIELD VERIFIED DIMENSIONS PROVIDED THAT THE OUT-TO-OUT DIMENSIONS REMAIN AS DETAILED.

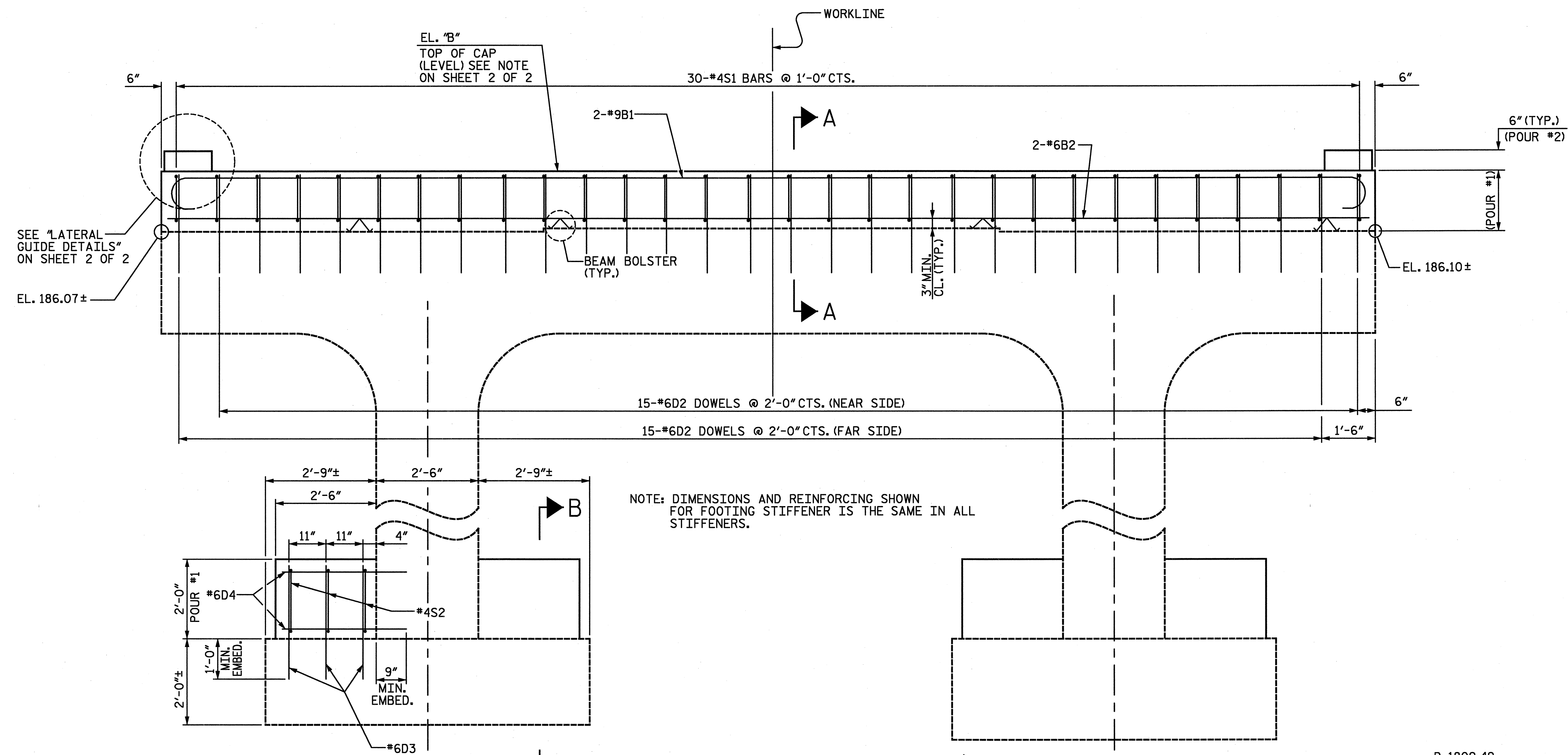

ELEVATION
(LOOKING UPSTATION)

NOTE: DIMENSIONS AND REINFORCING SHOWN FOR FOOTING STIFFENER IS THE SAME IN ALL STIFFENERS.

PROJECT NO. **B-5021**
ROBESON COUNTY
 BRIDGE: **167**

SHEET 1 OF 2

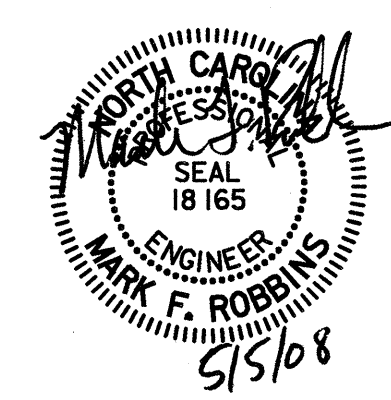
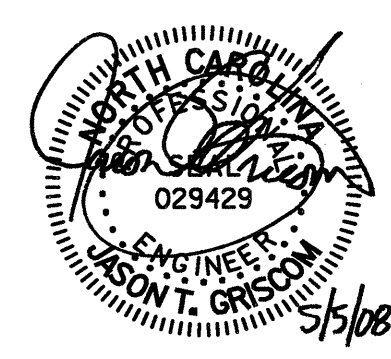

STATE OF NORTH CAROLINA
 DEPARTMENT OF TRANSPORTATION
 RALEIGH

**SUBSTRUCTURE
 BENT 2**

DRAWN BY: **TRL** DATE: **1-08**
 CHECKED BY: **TBQ** DATE: **3-08**

REVISION #1: REVISED PER REVIEW COMMENTS
 BY: **TJT** DATE: **5-08**
 CH'KD BY: **KGB** DATE: **5-08**

D-1809.49
STV / Ralph Whitehead Associates, Inc.
 1000 West Morehead St., Ste. 200
 Charlotte, NC 28208

REVISIONS					SHEET NO.
NO.	BY:	DATE:	NO.	DATE:	TOTAL SHEETS
1	STV	5-08	3		5-49
2			4		62

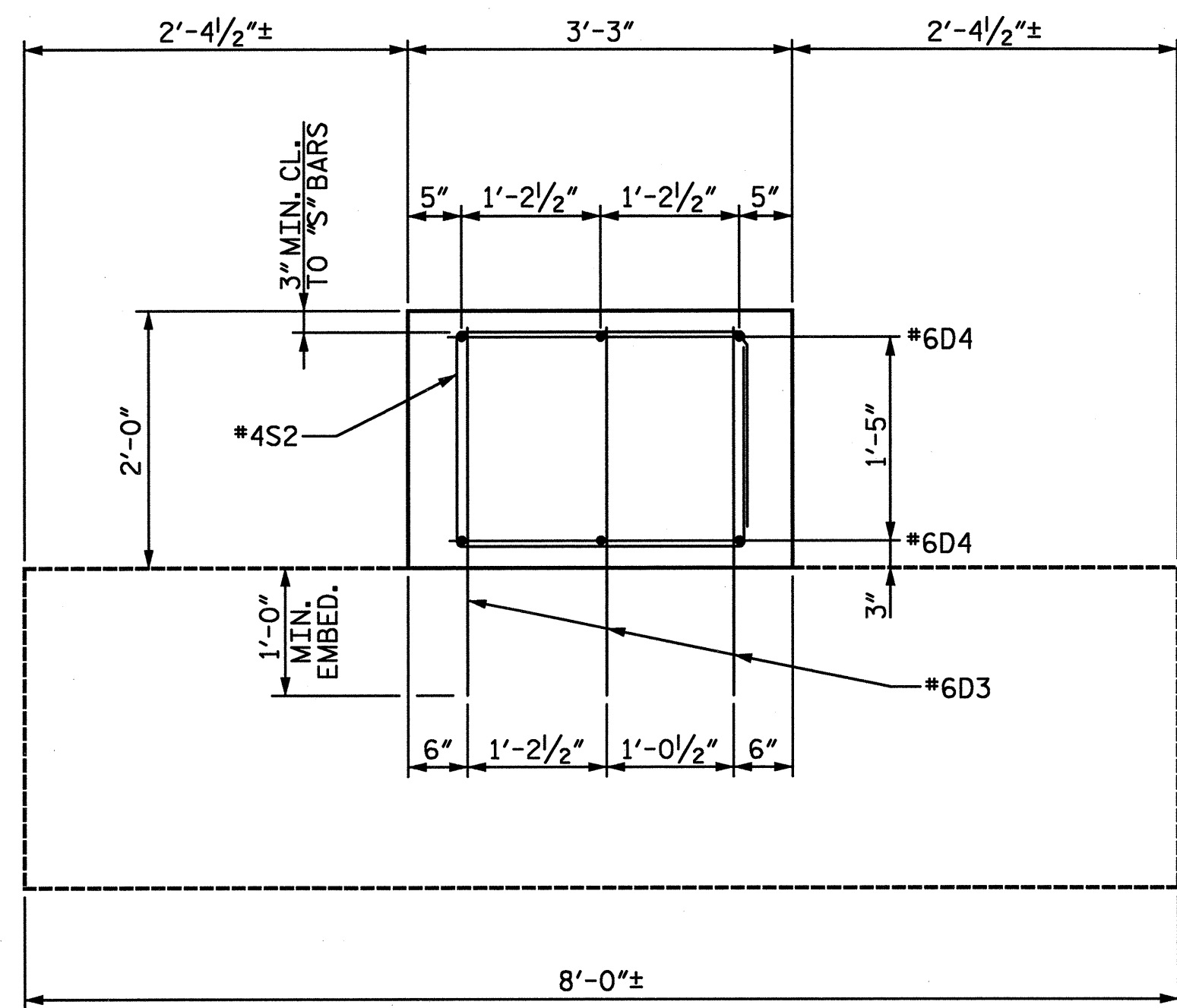

SECTION B-B

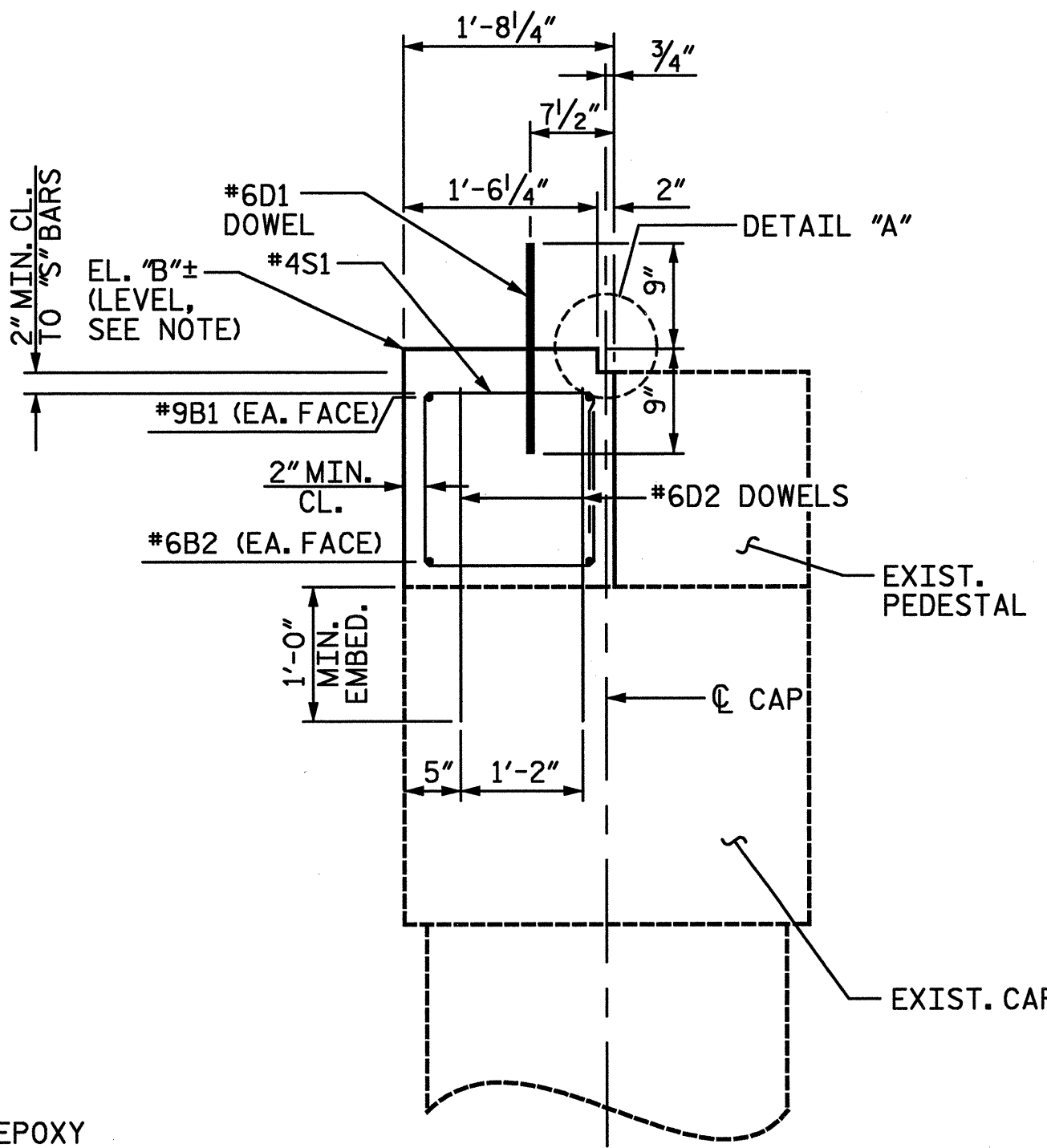

SECTION A-A

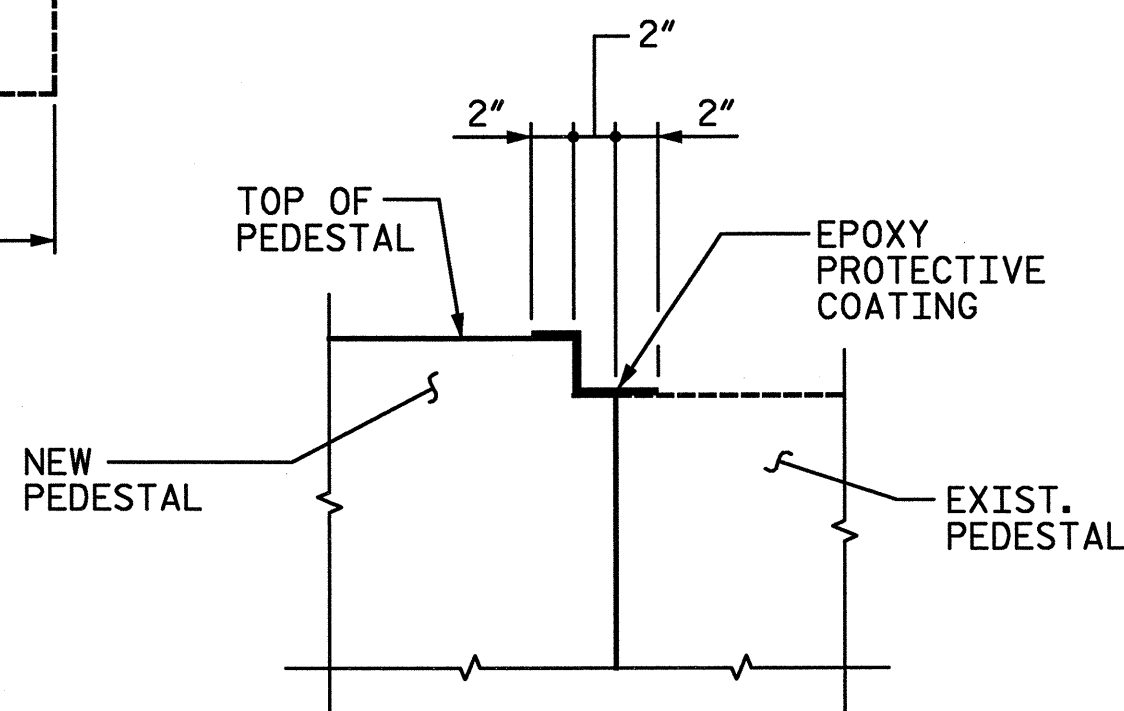

DETAIL "A"

NOTE: THE TOP SURFACES OF THE NEW AND EXISTING PEDESTAL SHALL BE CURED A MINIMUM OF 2" FROM THE COLD JOINT IN ACCORDANCE WITH THE STANDARD SPECIFICATIONS EXCEPT THE MEMBRANE CURING COMPOUND METHOD SHALL NOT BE USED.

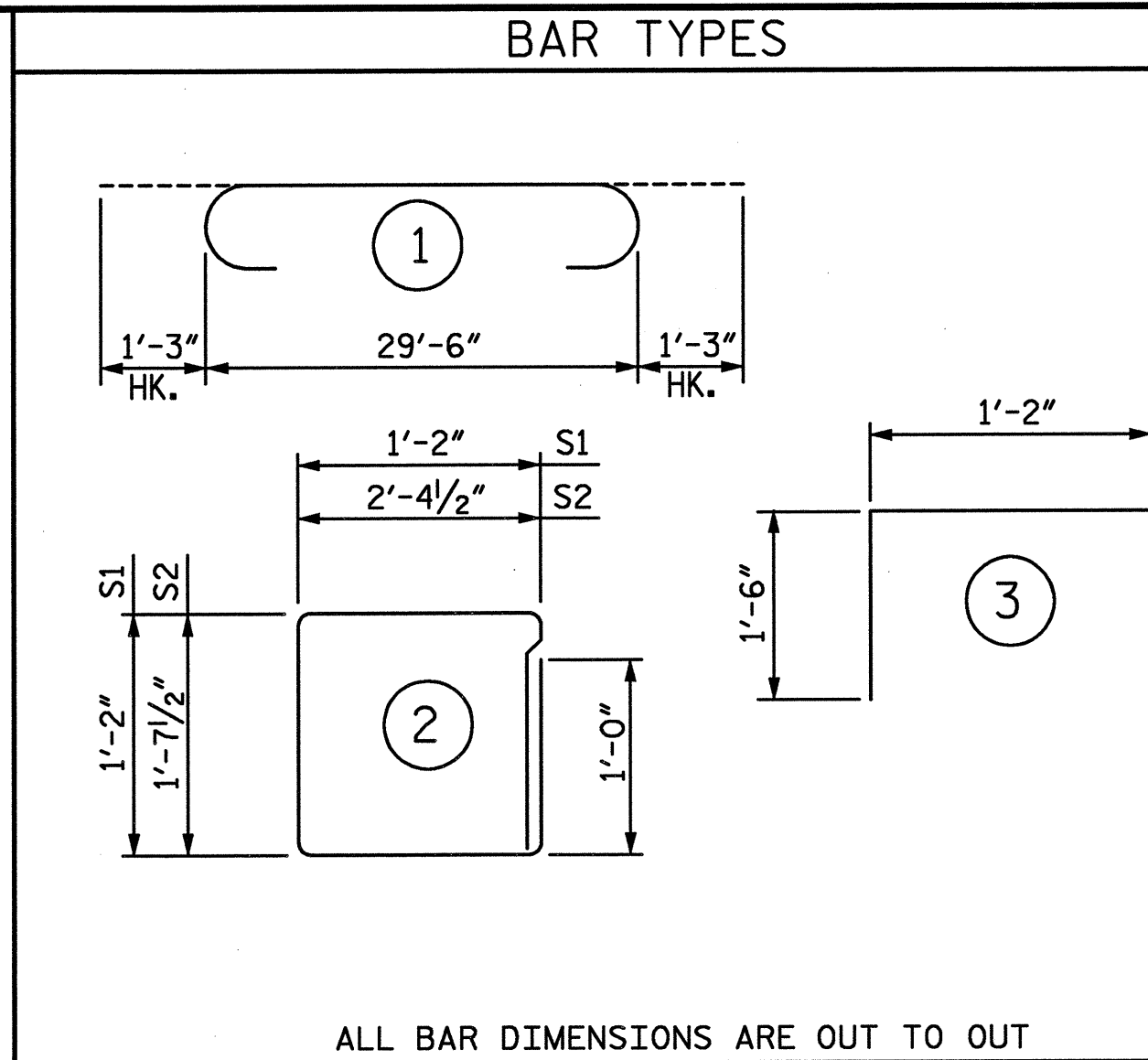

ALL BAR DIMENSIONS ARE OUT TO OUT

BILL OF MATERIAL						
BENT 2						
BAR	NO.	SIZE	TYPE	LENGTH	WEIGHT	
B1	2	9	①	32'-0"	218	
B2	2	6	STR.	29'-6"	89	
D1	18	6	STR.	1'-6"	41	
D2	30	6	STR.	2'-0"	90	
D3	36	6	STR.	2'-9"	149	
D4	24	6	STR.	3'-0"	108	
S1	30	4	②	5'-9"	115	
S2	12	4	②	9'-4"	75	
U1	4	4	③	4'-2"	11	
REINFORCING STEEL					LBS.	896
CLASS AA CONCRETE BREAKDOWN						
POUR 1 (CAP & FOOTING) CY					5.7	
POUR 2 (LATERAL GUIDE) CY					0.1	
TOTAL					CY	5.8

NOTE: DIMENSIONS AND ELEVATIONS SHOWN ARE FROM BEST INFORMATION AVAILABLE. CONTRACTOR SHALL MAKE ADJUSTMENTS TO PEDESTAL EL. "B" TO MAINTAIN 3 1/2" (4 1/2" MAX.) ASPHALT WEARING SURFACE @ C BEARING, MATCH EL. "D", AND TO MAINTAIN THE 16'-0" MIN. VERTICAL CLEARANCE. IF ANY ELEVATIONS ARE MODIFIED, THE CONTRACTOR IS RESPONSIBLE FOR ADJUSTING THE REINFORCING TO FIT THE PEDESTAL HEIGHT.

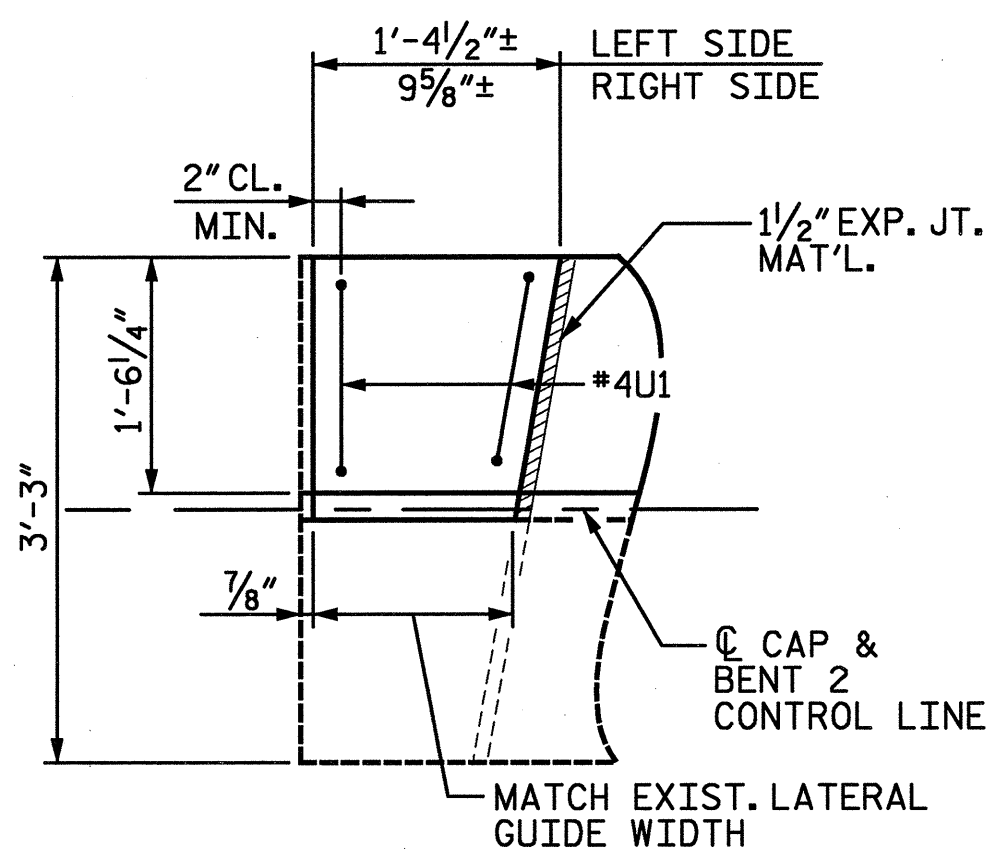

PLAN

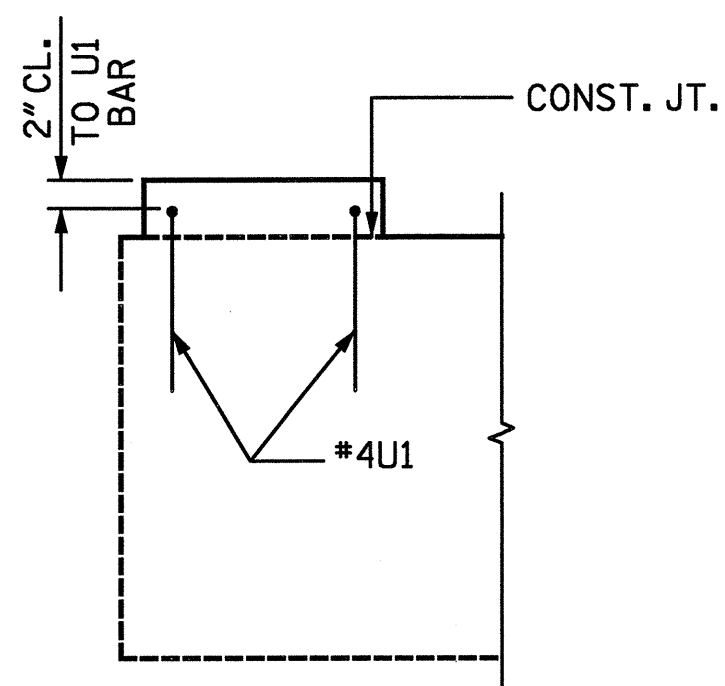

ELEVATION

LATERAL GUIDE DETAILS
(LEFT SIDE SHOWN, RIGHT SIDE SIMILAR)

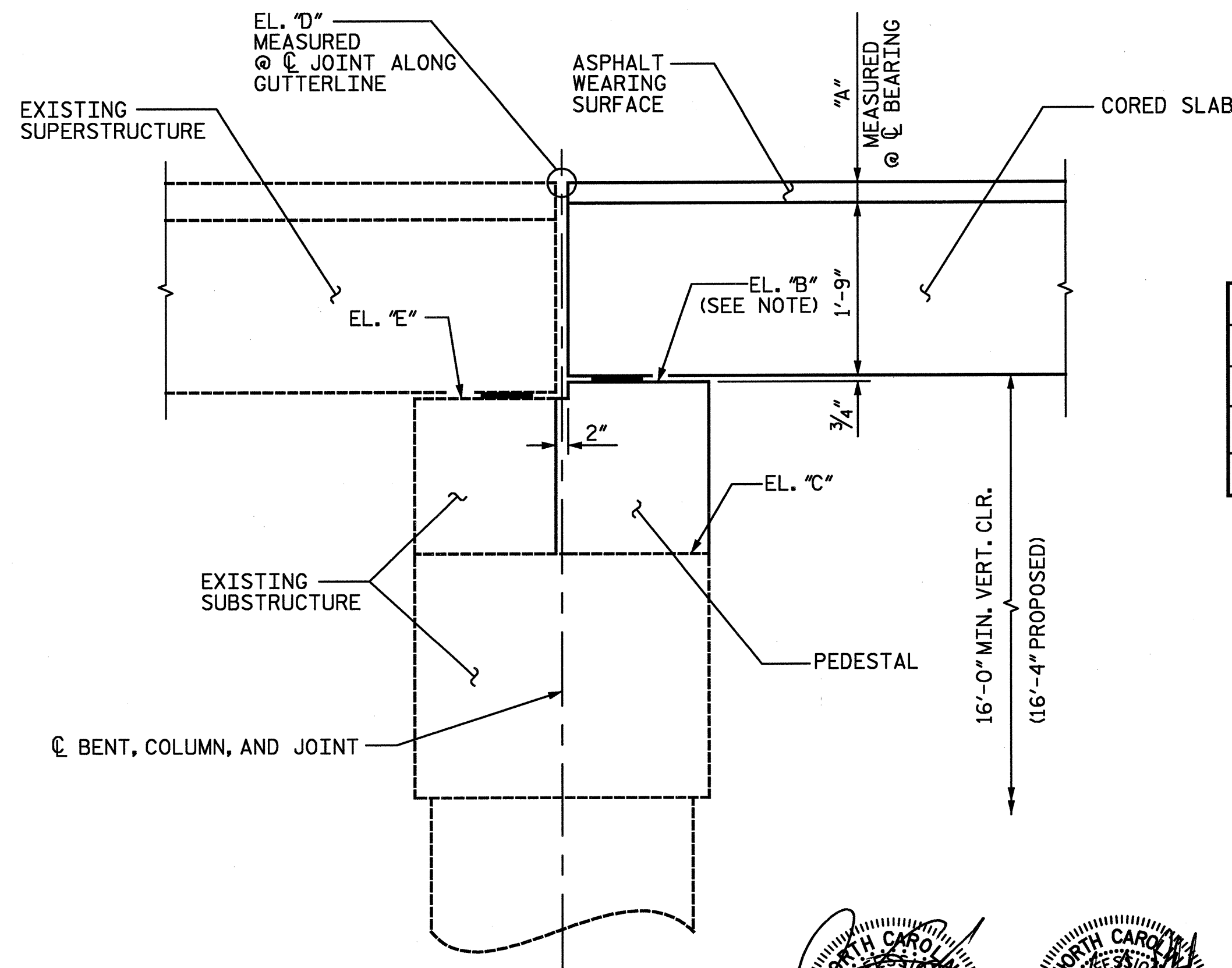

PEDESTAL HEIGHT

"A"	3 1/2"
"B"	187.86
"C"	186.08
"D"	189.96
"E"	187.71

PROJECT NO. **B-5021**
ROBESON COUNTY
 BRIDGE: **167**

SHEET 2 OF 2

STATE OF NORTH CAROLINA
 DEPARTMENT OF TRANSPORTATION
 RALEIGH

SUBSTRUCTURE
 BENT 2

REVISIONS

NO.	BY:	DATE:	NO.	BY:	DATE:	SHEET NO.
1			3			5-50
2			4			TOTAL SHEETS 67

DRAWN BY: **TRL** DATE: **1-08**
 CHECKED BY: **TBQ** DATE: **3-08**

D-1809.50

STV / Ralph Whitehead Associates, Inc.
 1000 West Morehead St., Ste. 200
 Charlotte, NC 28208

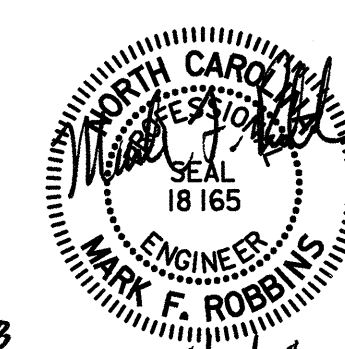
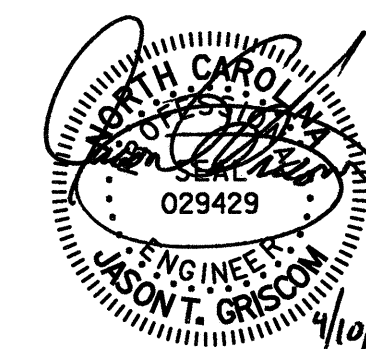

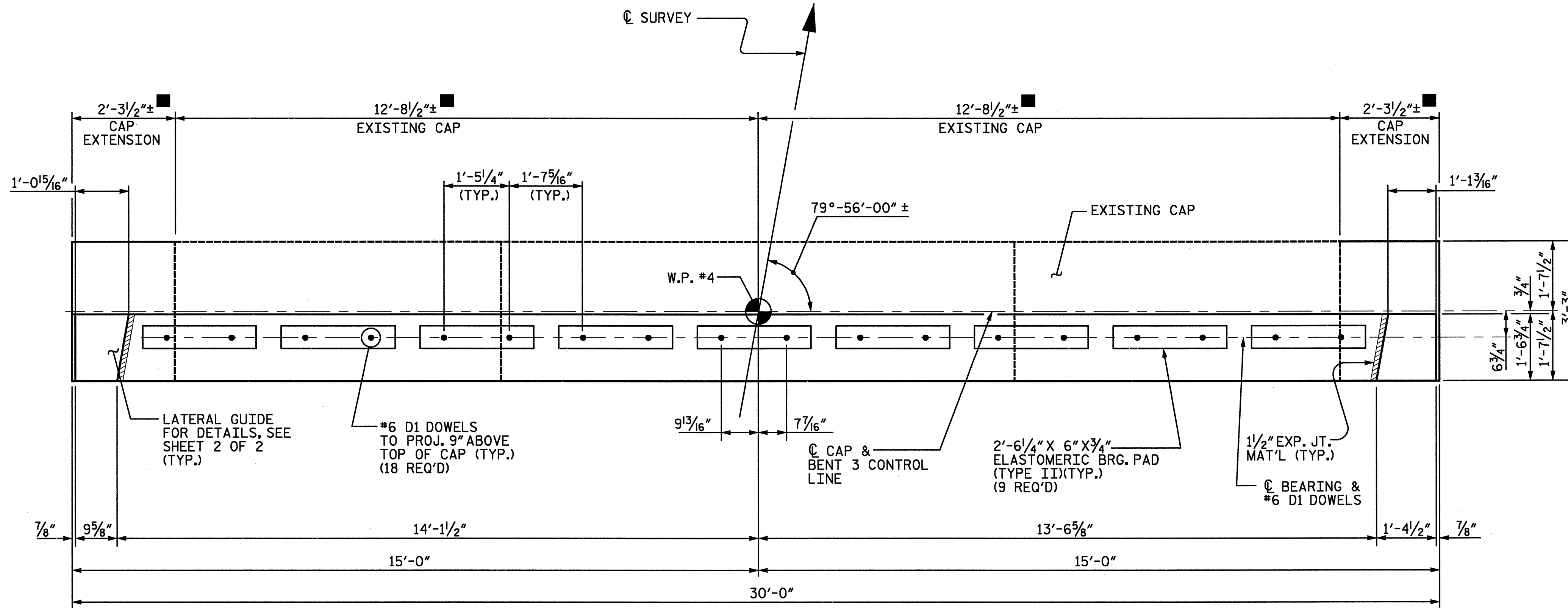

PLAN

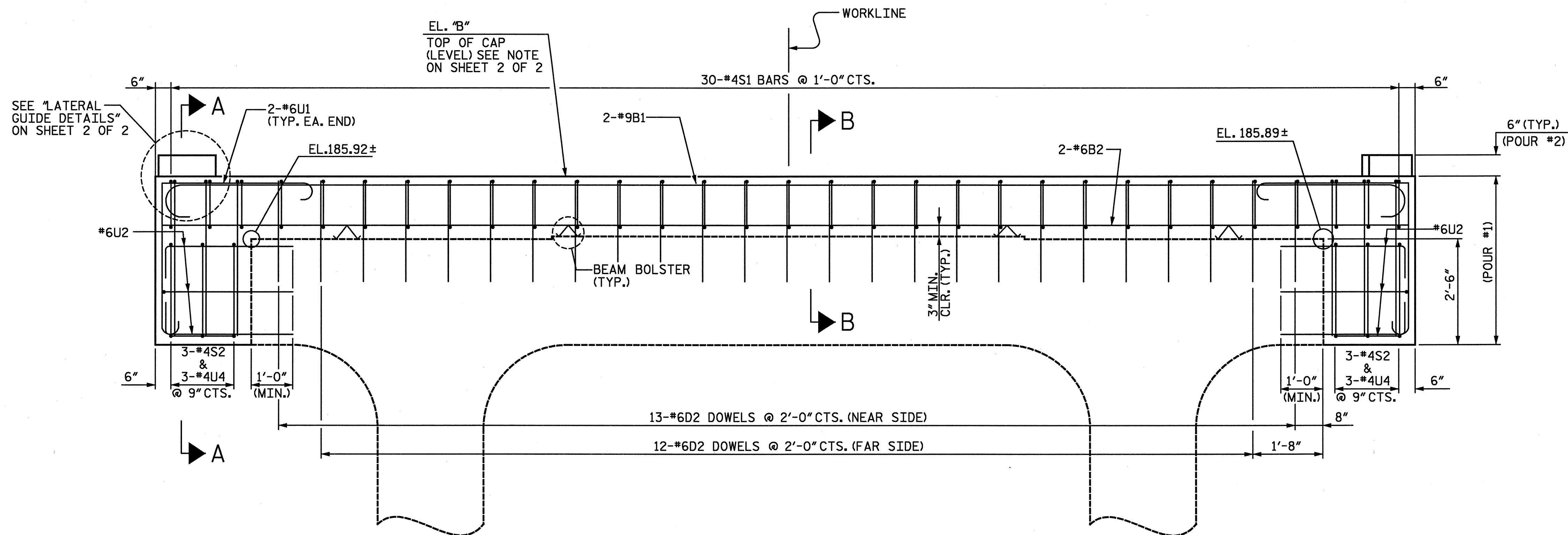

ELEVATION (LOOKING UPSTATION)

NOTES

- REINFORCING STEEL MAY BE SHIFTED AS NECESSARY TO CLEAR DOWELS. THE LATERAL GUIDES ARE NOT TO BE POURED UNTIL AFTER THE CORED SLAB UNITS ARE IN PLACE.
- ALL ELEVATIONS ARE TO BE VERIFIED BY THE ENGINEER.
- A HIGH EARLY STRENGTH PORTLAND CEMENT CONCRETE SHALL BE USED TO ACHIEVE A MINIMUM COMPRESSIVE STRENGTH OF 5000 PSI PRIOR TO PLACING CORED SLAB UNITS. SEE STANDARD SPECIFICATION SECTION 1000 FOR DETAILS.
- #6D2 AND #6U2 DOWELS SHALL BE ADHESIVELY ANCHORED USING AN APPROVED ADHESIVE CONSIDERING LOAD RESISTANCE, IN-SERVICE AND INSTALLATION TEMPERATURE, AVAILABILITY OF COMPREHENSIVE INSTALLATION INSTRUCTIONS, AND CREEP. ANCHORS SHALL BE INSTALLED TO THE MINIMUM EMBEDMENT DEPTHS AS SHOWN ON PLANS. LEVEL ONE FIELD TESTING IS REQUIRED, AND THE YIELD LOAD OF THE DOWEL IS 26 KIPS. FOR ADHESIVELY ANCHORED DOWELS, SEE SPECIAL PROVISIONS.
- DIMENSIONS AND ELEVATIONS ARE BASED ON AS-BUILT DIMENSIONS AND FIELD SURVEY INFORMATION. CONTRACTOR SHALL FIELD VERIFY DIMENSIONS PRIOR TO CONSTRUCTION. REINFORCING AND CONCRETE CAP EXTENSIONS SHALL BE ADJUSTED TO MATCH FIELD VERIFIED DIMENSIONS PROVIDED THAT THE OUT-TO-OUT DIMENSIONS REMAIN AS DETAILED.

PROJECT NO. **B-5021**
ROBESON COUNTY
 BRIDGE: **167**

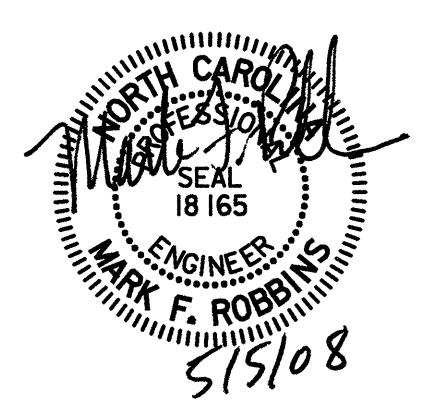
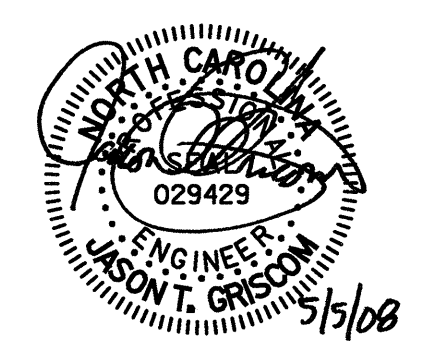

SHEET 1 OF 2

STATE OF NORTH CAROLINA
 DEPARTMENT OF TRANSPORTATION
 RALEIGH

**SUBSTRUCTURE
 BENT 3**

REVISION #1: REVISED PER REVIEW COMMENTS
 BY: TJT DATE: 5-08
 CH'KD BY: KGB DATE: 5-08

DRAWN BY: TRL DATE: 1-08
 CHECKED BY: TBQ DATE: 3-08

D-1809.51
 STV / Ralph Whitehead Associates, Inc.
 1000 West Morehead St., Ste. 200
 Charlotte, NC 28208

REVISIONS					SHEET NO.
NO.	BY:	DATE:	NO.	BY:	DATE:
1	STV	5-08	3		
2			4		

TOTAL SHEETS: 62

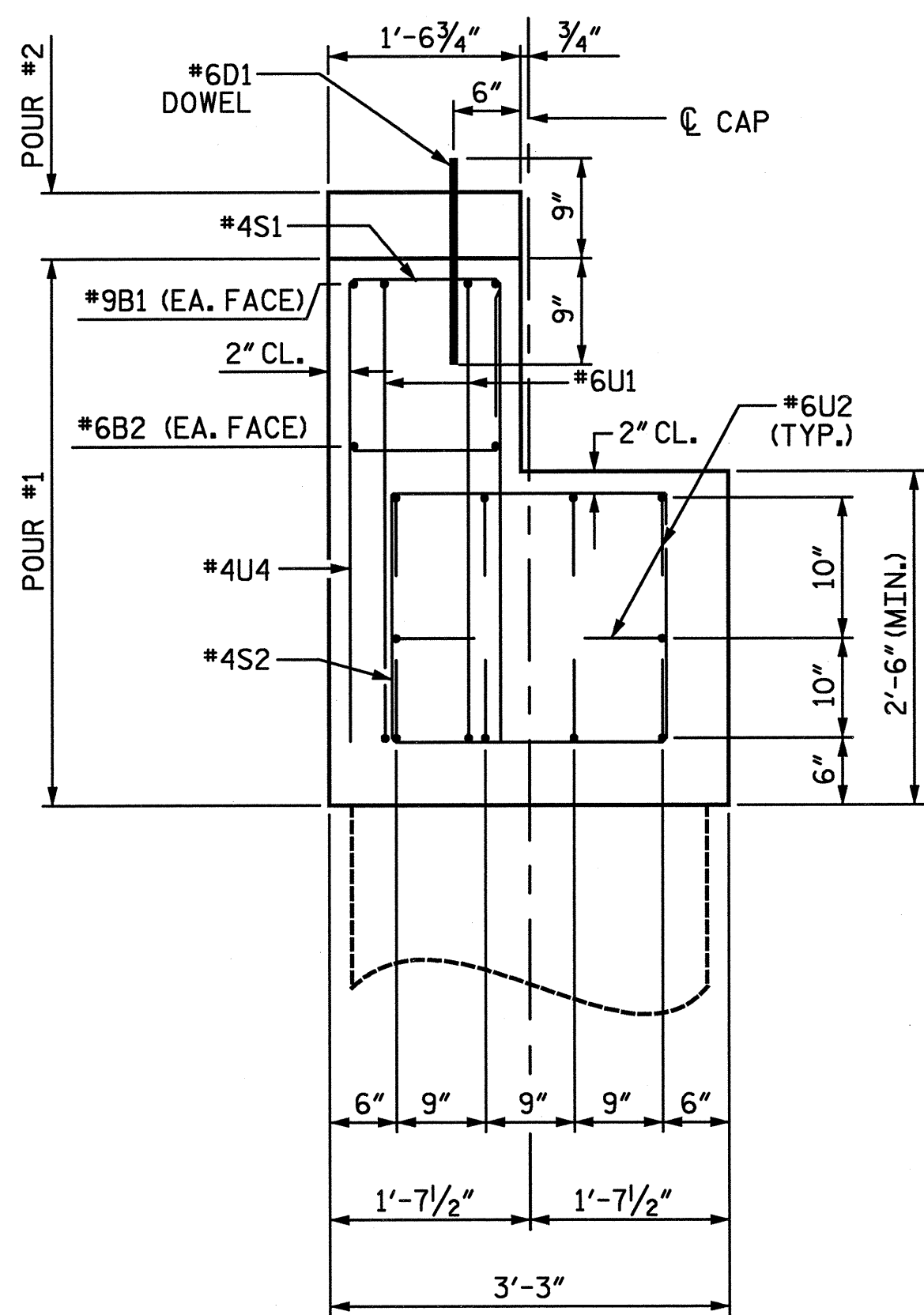

SECTION A-A

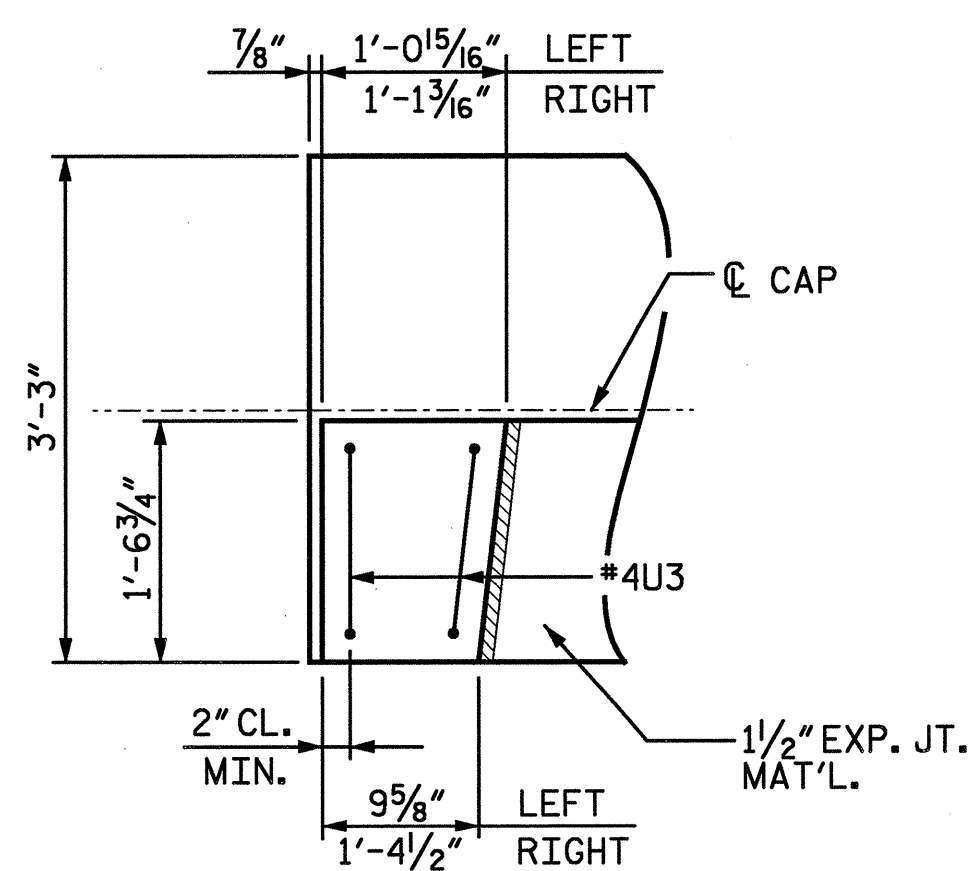

PLAN

LATERAL GUIDE DETAILS
(LEFT SIDE SHOWN, RIGHT SIDE SIMILAR)

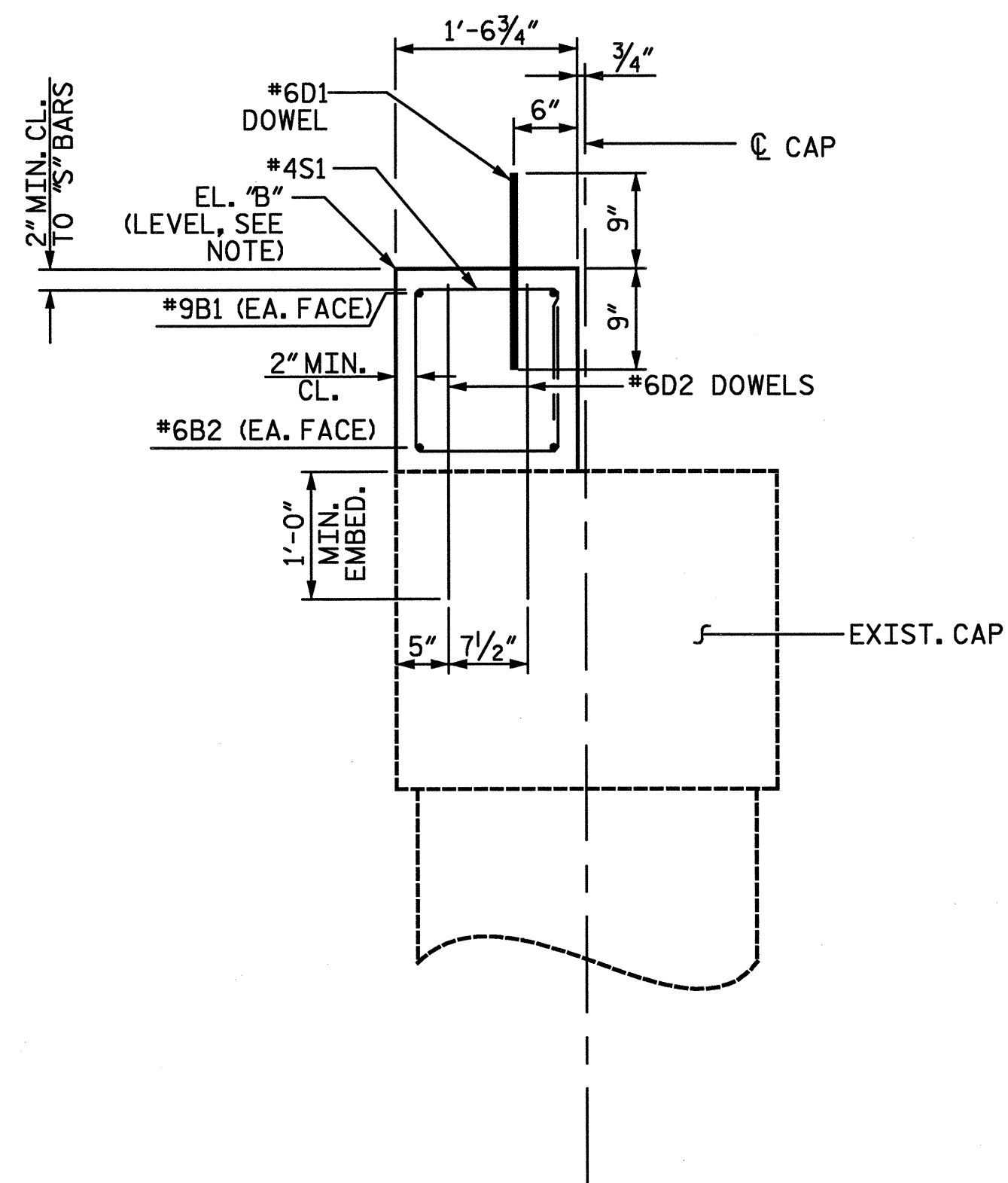

SECTION B-B

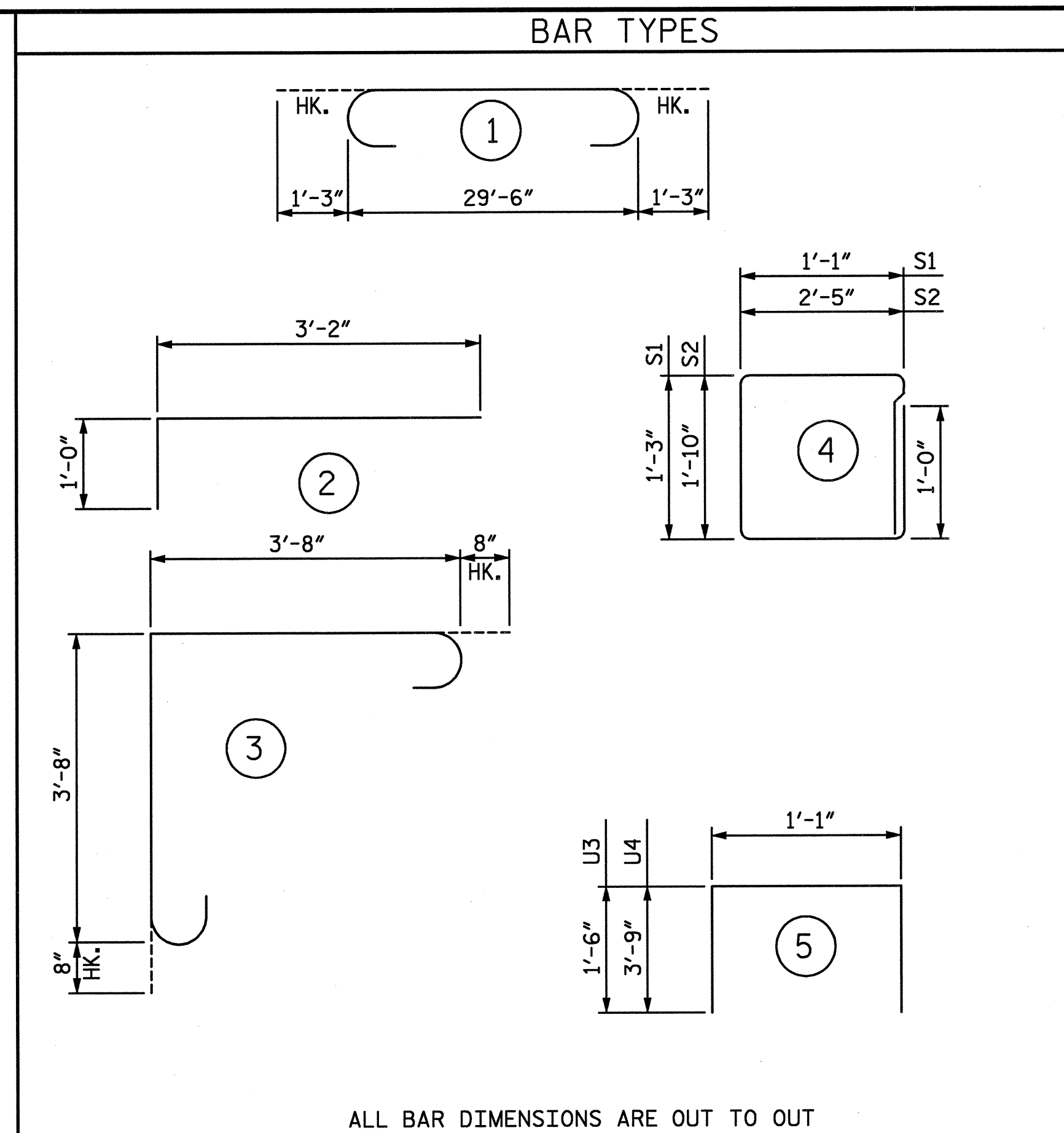

ALL BAR DIMENSIONS ARE OUT TO OUT

BILL OF MATERIAL

BENT 3						
BAR	NO.	SIZE	TYPE	LENGTH	WEIGHT	
B1	2	9	①	32'-0"	218	
B2	2	6	STR.	29'-6"	87	
D1	18	6	STR.	1'-6"	41	
D2	25	6	STR.	2'-0"	75	
S1	30	4	④	5'-8"	114	
S2	6	4	④	9'-6"	38	
U1	4	6	③	8'-8"	52	
U2	20	6	②	4'-2"	125	
U3	4	4	⑤	4'-1"	11	
U4	6	4	⑤	8'-7"	34	
REINFORCING STEEL					LBS.	797
CLASS AA CONCRETE BREAKDOWN						
POUR 1 (CAP)					CY	4.3
POUR 2 (LATERAL GUIDE)					CY	0.1
TOTAL					CY	4.4

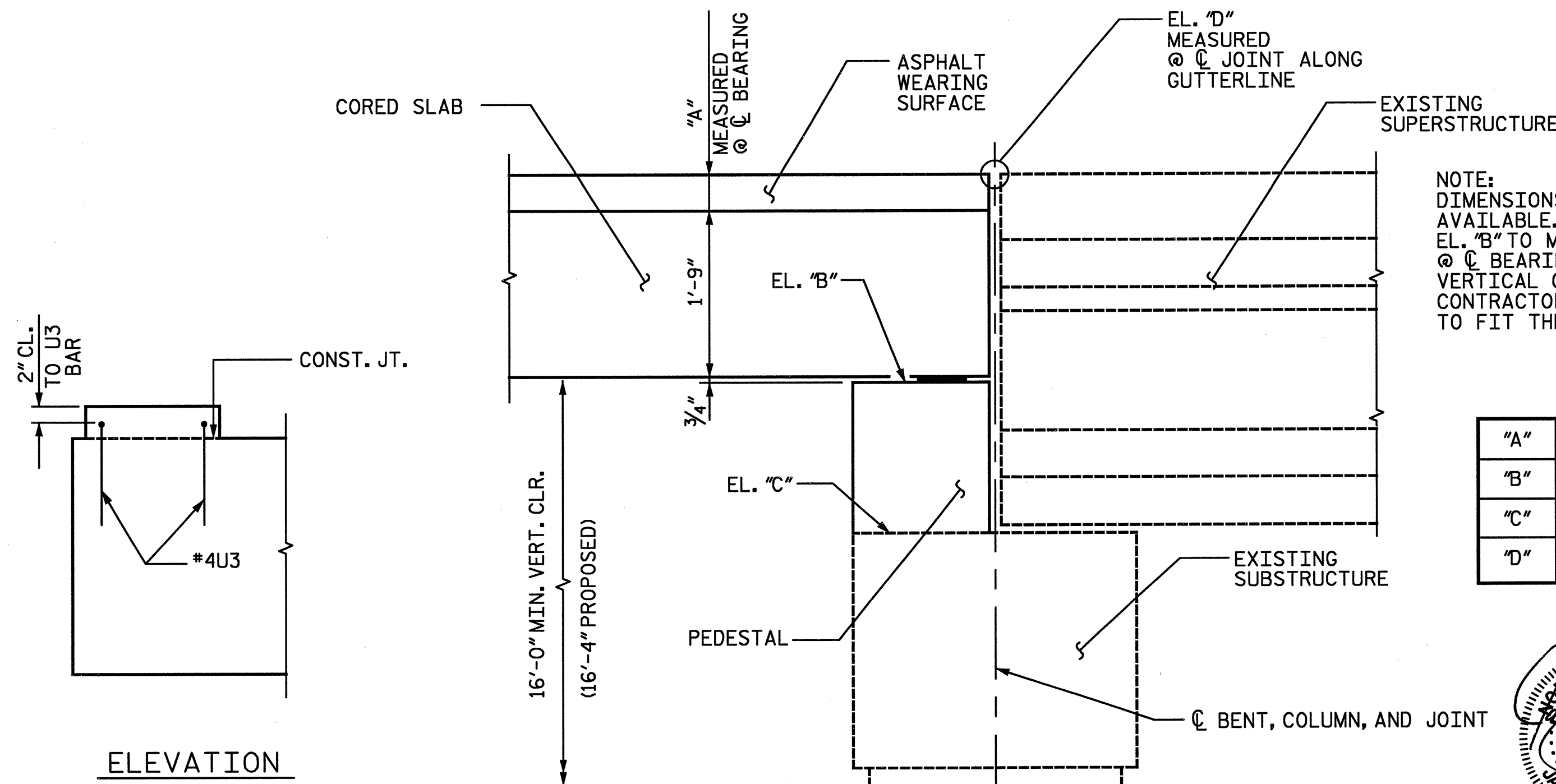

NOTE:
DIMENSIONS AND ELEVATIONS SHOWN ARE FROM BEST INFORMATION AVAILABLE. CONTRACTOR SHALL MAKE ADJUSTMENTS TO PEDESTAL EL. "B" TO MAINTAIN 3 1/2" (4 1/2" MAX.) ASPHALT WEARING SURFACE @ C BEARING, MATCH EL. "D", AND TO MAINTAIN THE 16'-0" MIN. VERTICAL CLEARANCE. IF ANY ELEVATIONS ARE MODIFIED, THE CONTRACTOR IS RESPONSIBLE FOR ADJUSTING THE REINFORCING TO FIT THE PEDESTAL HEIGHT.

"A"	3 1/2"
"B"	187.64
"C"	185.91
"D"	189.74

PROJECT NO. **B-5021**
ROBESON COUNTY
BRIDGE: **167**

SHEET 2 OF 2

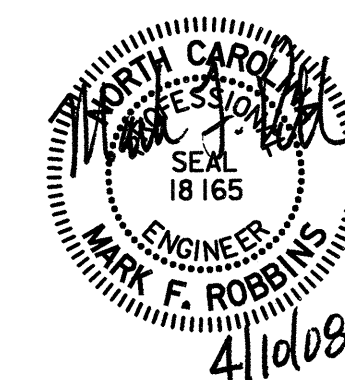
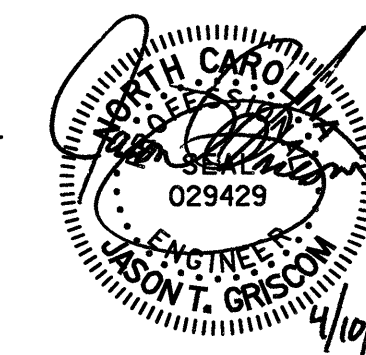

STATE OF NORTH CAROLINA
DEPARTMENT OF TRANSPORTATION
RALEIGH

SUBSTRUCTURE
BENT 3

REVISIONS

NO.	BY:	DATE:	NO.	BY:	DATE:	SHEET NO.
1			3			5-52
2			4			TOTAL SHEETS 62

DRAWN BY: **TRL** DATE: **1-08**
CHECKED BY: **TBQ** DATE: **3-08**

D-1809.52

STV / Ralph Whitehead Associates, Inc.
1000 West Morehead St., Ste. 200
Charlotte, NC 28208

NOTES:

- 1. REPAIRS SHALL BE IMPLEMENTED DURING SPAN C REPLACEMENT.
- 2. FOR EPOXY RESIN INJECTION, SEE SPECIAL PROVISIONS.

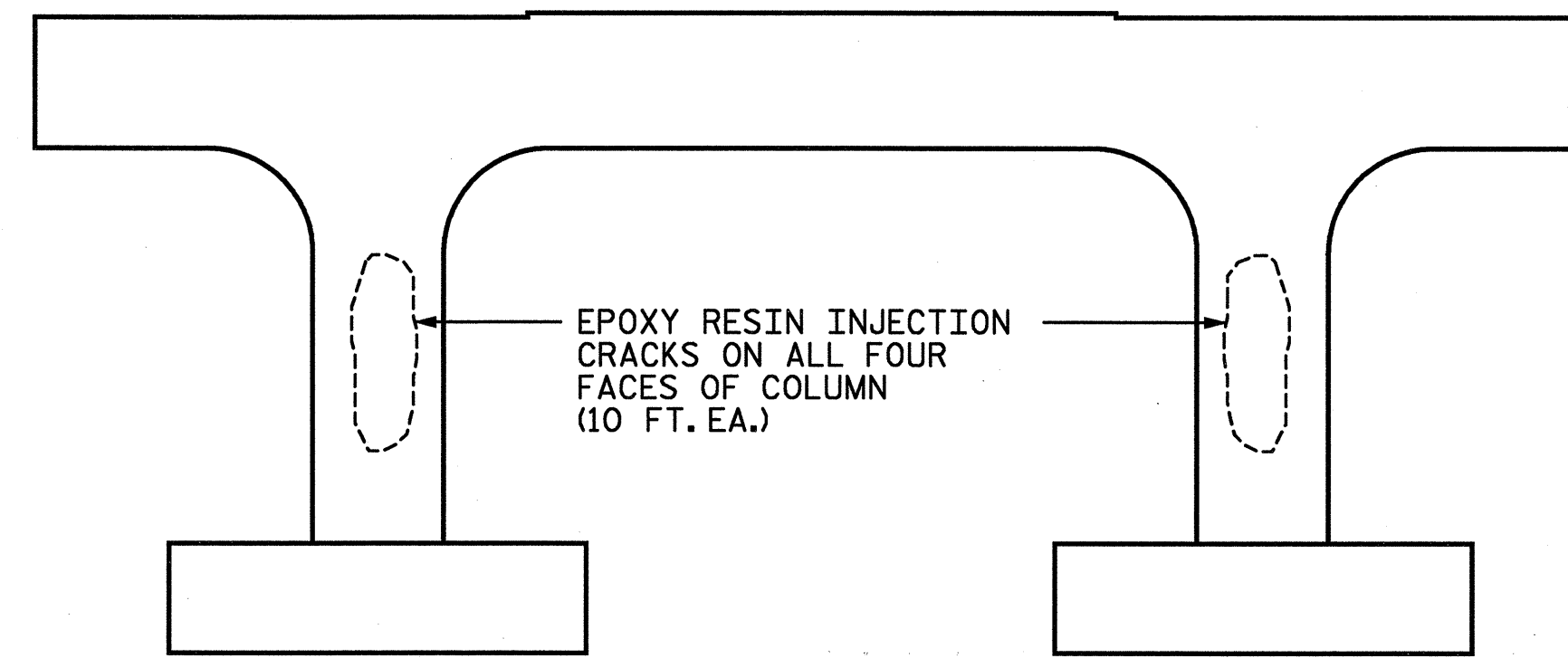

BENT 3 ELEVATION
(LOOKING EAST)

PROJECT NO. B-5021
ROBESON _____ COUNTY
BRIDGE: 167

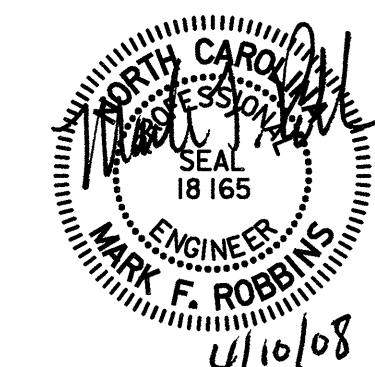
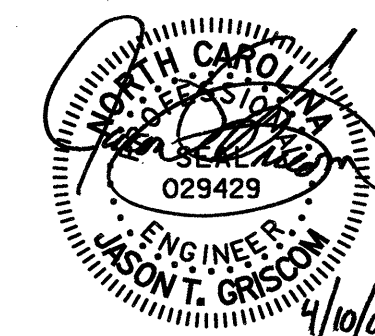

STATE OF NORTH CAROLINA
DEPARTMENT OF TRANSPORTATION
RALEIGH

**SUBSTRUCTURE
REPAIRS**

REVISIONS						SHEET NO.
NO.	BY:	DATE:	NO.	BY:	DATE:	
1			3			5-53
2			4			TOTAL SHEETS 62

D-1809.53

STV / Ralph Whitehead Associates, Inc.
1000 West Morehead St., Ste. 200
Charlotte, NC 28208

timothy.townsend 4/10/2008 11:32:44 AM N:\PROJ\251348\B5021\Bridg 167\ustation\Finals\substructure repairs.dgn

DRAWN BY : JAD DATE : 3-08
CHECKED BY : JTG DATE : 3-08

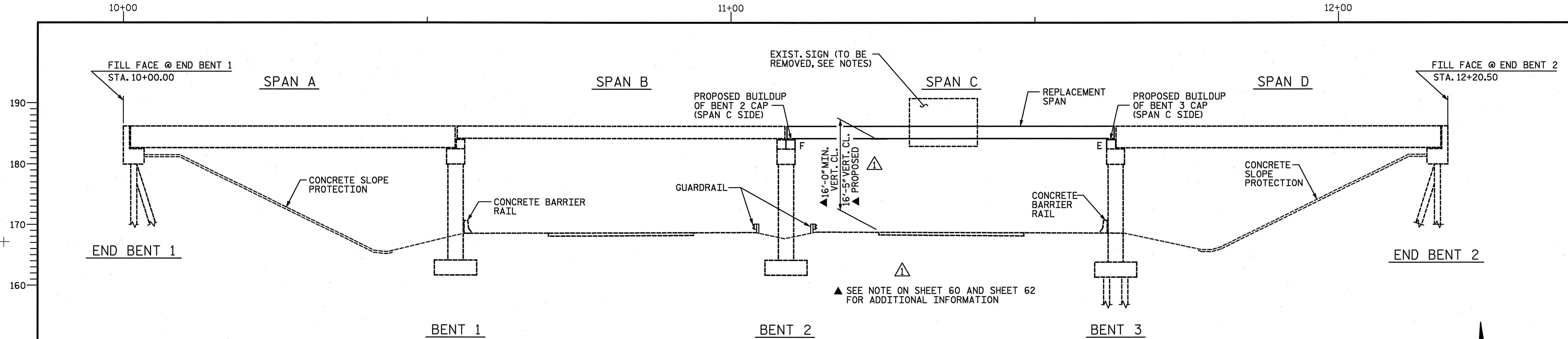

ELEVATION

(SECTIONS AT BENTS AND END BENTS ARE AT RIGHT ANGLES)

TOTAL LENGTH OF BRIDGE = 220'-6" ± (FILL FACE TO FILL FACE ALONG C SURVEY)

ALL DIMENSIONS IN THESE PLANS ARE BASED ON BEST AVAILABLE INFORMATION. THE CONTRACTOR SHALL VERIFY DIMENSIONS IN FIELD PRIOR TO CONSTRUCTION AND ANY FABRICATION. CONTRACTOR SHALL NOTIFY THE ENGINEER OF ANY DISCREPANCIES SUCH THAT NECESSARY ADJUSTMENTS BE MADE BY THE CONTRACTOR.

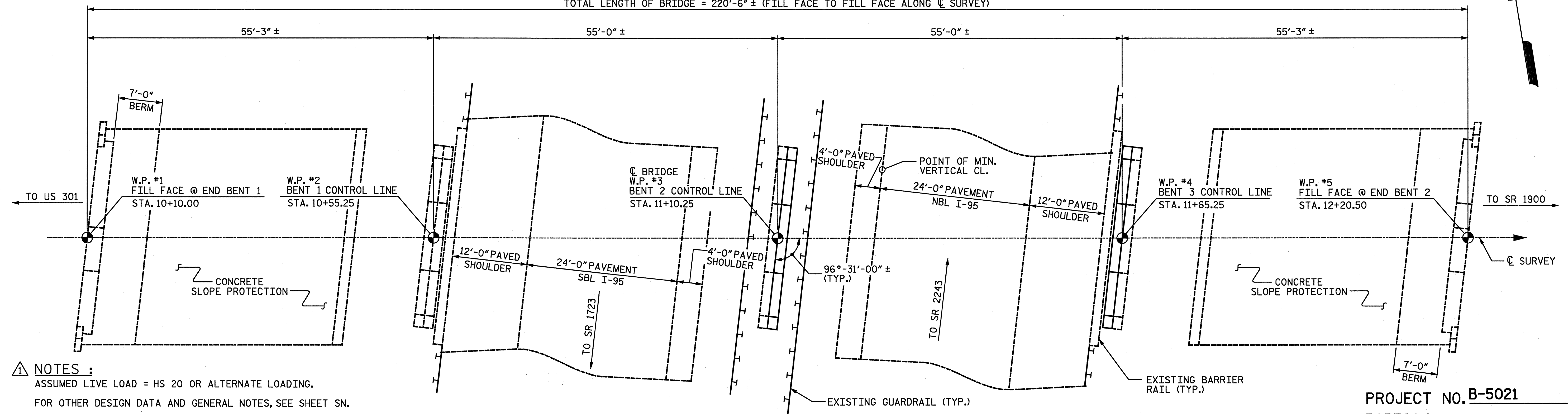

PLAN

(PILES AND COLUMNS NOT SHOWN IN PLAN VIEW FOR CLARITY)

- NOTES :**
- ASSUMED LIVE LOAD = HS 20 OR ALTERNATE LOADING.
 - FOR OTHER DESIGN DATA AND GENERAL NOTES, SEE SHEET SN.
 - CORED SLABS HAVE BEEN DESIGNED BY THE STRENGTH DESIGN METHOD AS SPECIFIED IN AASHTO STANDARD SPECIFICATIONS.
 - SPAN C OF THE EXISTING STRUCTURE CONSISTING OF 55'-0' PRESTRESSED CONCRETE GIRDERS, 24'-0" CLEAR ROADWAY WIDTH, REINFORCED CONCRETE DECK SHALL BE REMOVED. FOR PARTIAL REMOVAL OF EXISTING STRUCTURE, SEE SPECIAL PROVISIONS.
 - FOR PRESTRESSED CONCRETE MEMBERS, SEE SPECIAL PROVISIONS.
 - FOR SUBMITTAL OF WORKING DRAWINGS, SEE SPECIAL PROVISIONS.
 - FOR FALSEWORK AND FORMWORK, SEE SPECIAL PROVISIONS.
 - THE EXISTING 15' X 10' SIGN ATTACHED TO THE BRIDGE DECK SHALL BE REMOVED INTACT AND DELIVERED TO THE BRIDGE MAINTENANCE YARD AS DIRECTED BY THE ENGINEER. REMOVAL AND TRANSPORT OF THE EXISTING SIGN SHALL BE PAID FOR IN THE PARTIAL REMOVAL OF EXISTING STRUCTURE.
 - FOR CRANE SAFETY, SEE SPECIAL PROVISIONS.
 - FOR MAINTENANCE AND PROTECTION OF TRAFFIC BENEATH PROPOSED STRUCTURE, SEE SPECIAL PROVISIONS.

REVISION #1: REVISED PER REVIEW COMMENTS
 BY: TJT DATE: 5-08
 CH'KD BY: KGB DATE: 5-08

TOTAL BILL OF MATERIAL						
	PARTIAL REMOVAL OF EXISTING STRUCTURE	CLASS AA CONCRETE	REINFORCING STEEL	CONCRETE BRIDGE RAIL	ELASTOMERIC BEARINGS	3'-0" X 1'-9" PRESTRESSED CONCRETE CORED SLABS
	LUMP SUM	CU. YDS.	LBS.	LIN. FT.	LUMP SUM	LIN. FT.
SUPERSTRUCTURE	LUMP SUM			109.75	LUMP SUM	493.88
BENT 2		5.7	885			
BENT 3		4.2	787			
TOTAL	LUMP SUM	9.9	1,672	109.75	LUMP SUM	493.88

PROJECT NO. **B-5021**
ROBESON COUNTY
 BRIDGE: **169**
 MODIFICATION OF BRIDGE NO. 169

STATE OF NORTH CAROLINA
 DEPARTMENT OF TRANSPORTATION
 RALEIGH
GENERAL DRAWING
BRIDGE OVER I-95
ON SR 1718
BETWEEN US 301
AND SR 1900

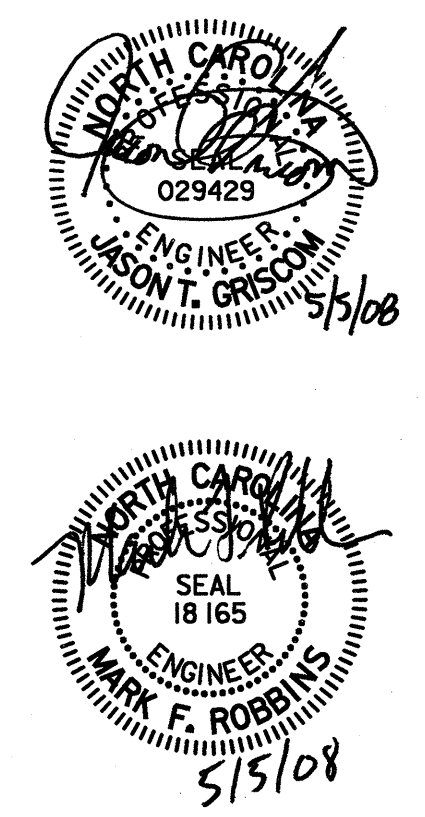

DRAWN BY: **TRL** DATE: **01-08**
 CHECKED BY: **PEK** DATE: **02-08**

D-1809.54
STV/Ralph Whitehead Associates, Inc.
 1000 West Morehead St., Ste. 200
 Charlotte, NC 28208

REVISIONS						SHEET NO.
NO.	BY:	DATE:	NO.	BY:	DATE:	
1	STV	5-08	3			5-54
2			4			TOTAL SHEETS 62

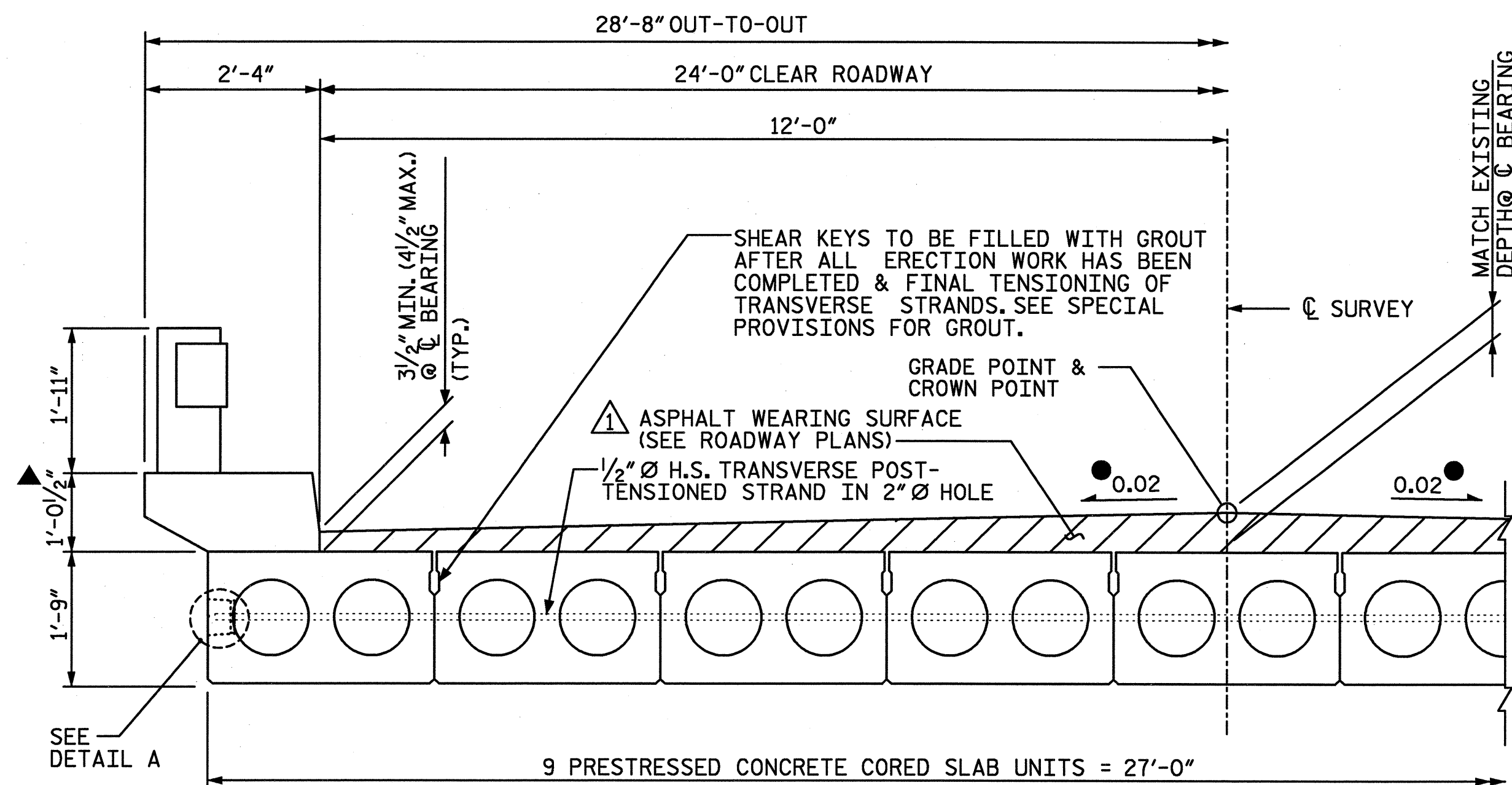

TYPICAL HALF SECTION
(BRIDGE SYMMETRIC ABOUT C SURVEY)

▲ CURB HEIGHT MAY NEED TO BE ADJUSTED TO MATCH TOP OF CURB IN ADJACENT SPAN. REINFORCING SHALL BE ADJUSTED TO MATCH THE REVISED CURB HEIGHT.

CONTRACTOR SHALL MAKE A SMOOTH TRANSITION TO MATCH EXISTING CROSS SLOPE ON ROADWAY APPROACHES.

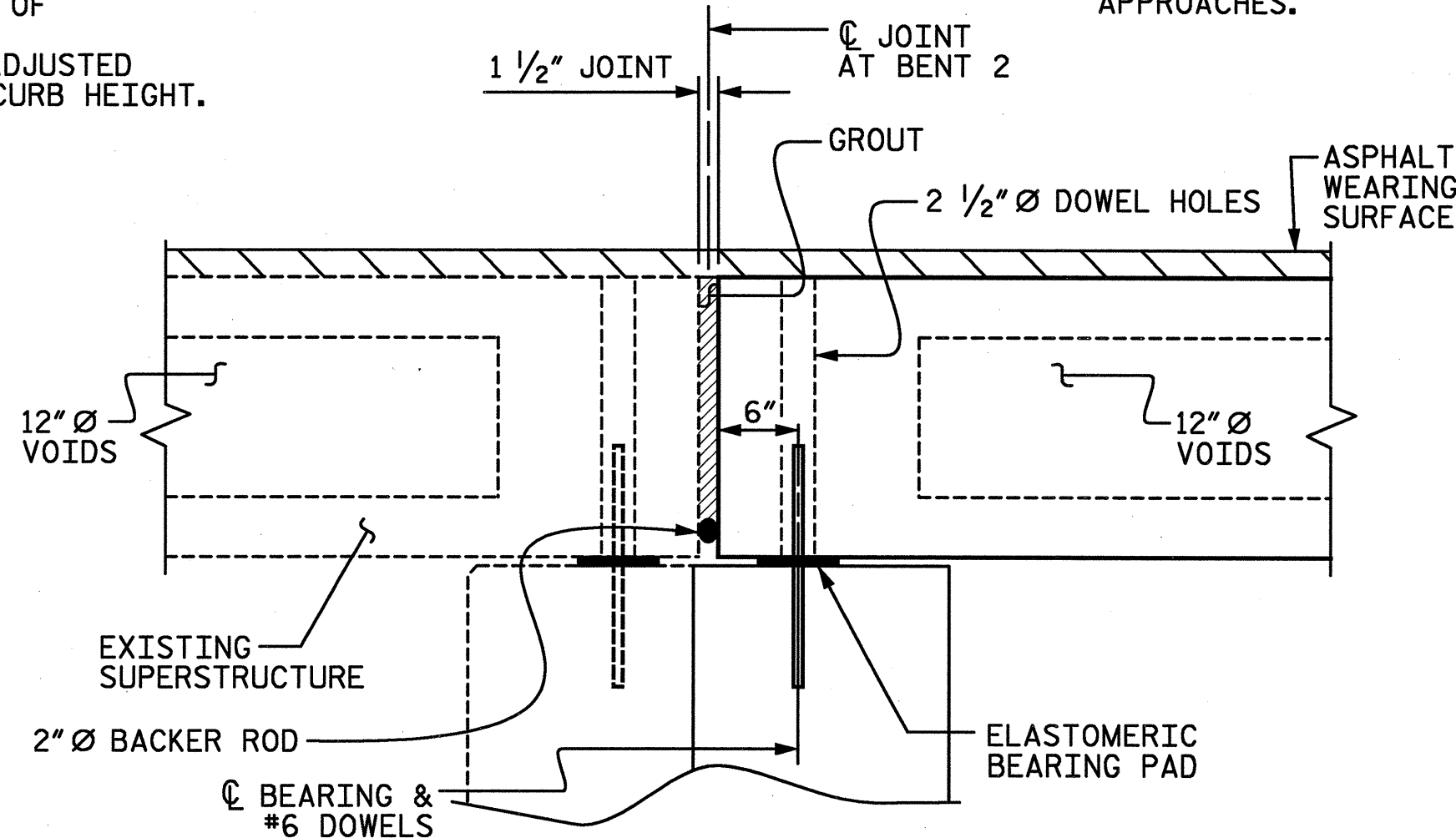

SECTION AT BENT 2

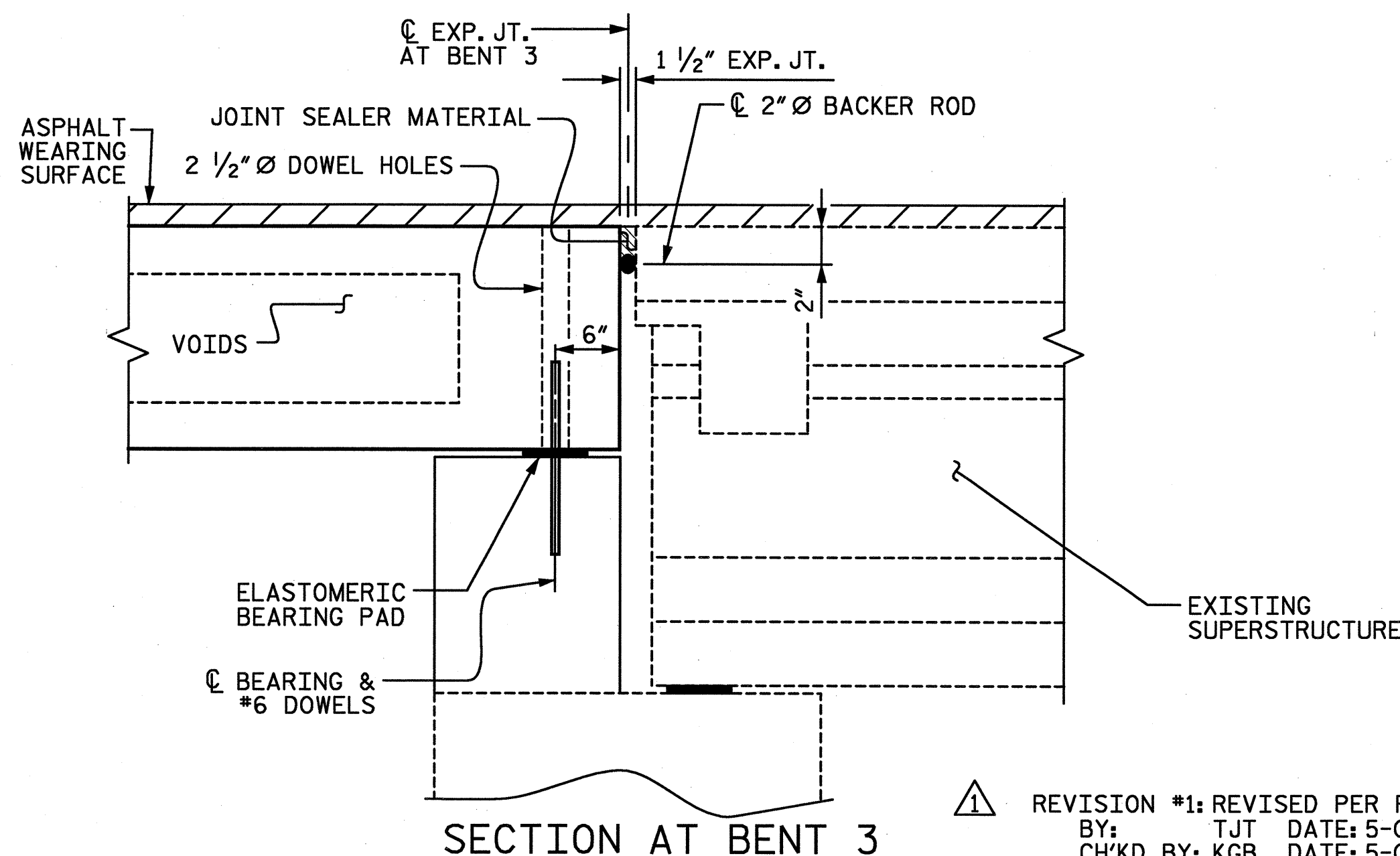

SECTION AT BENT 3

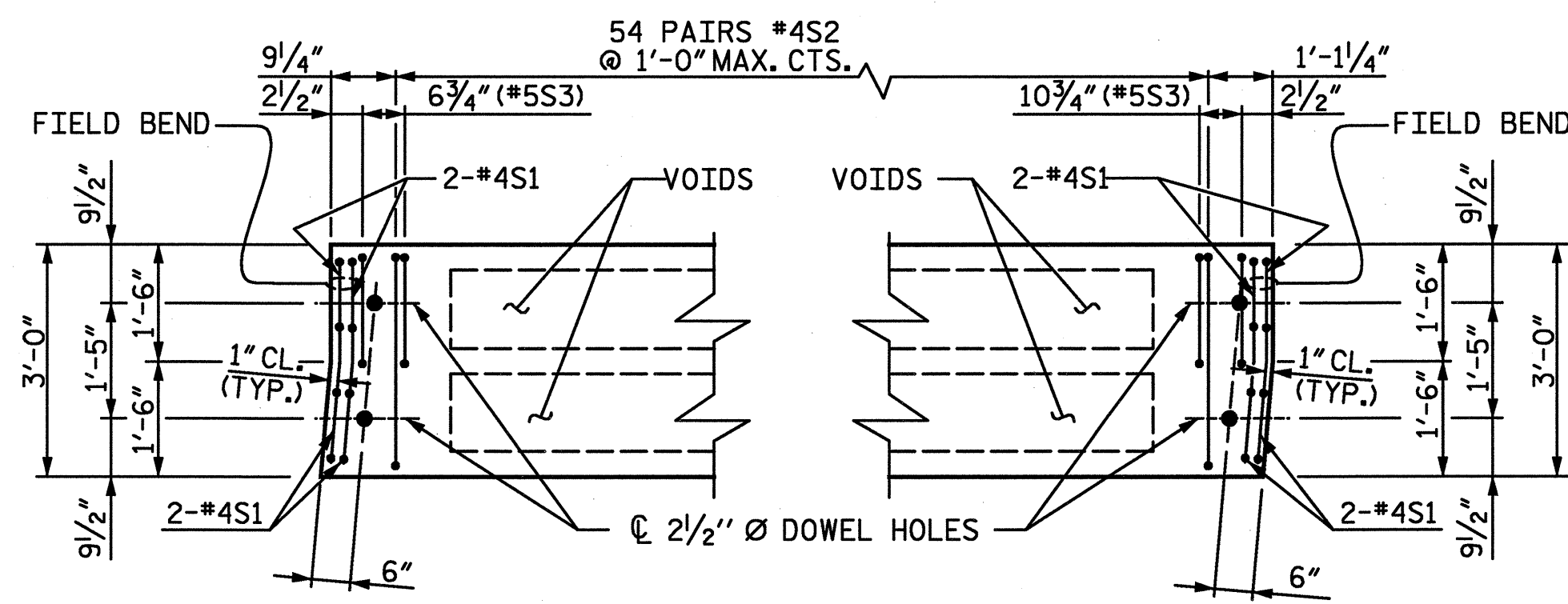

PART PLAN EXTERIOR SLAB SECTION

(LEFT SIDE SHOWN, RIGHT SIDE SIMILAR BY SYMMETRY)

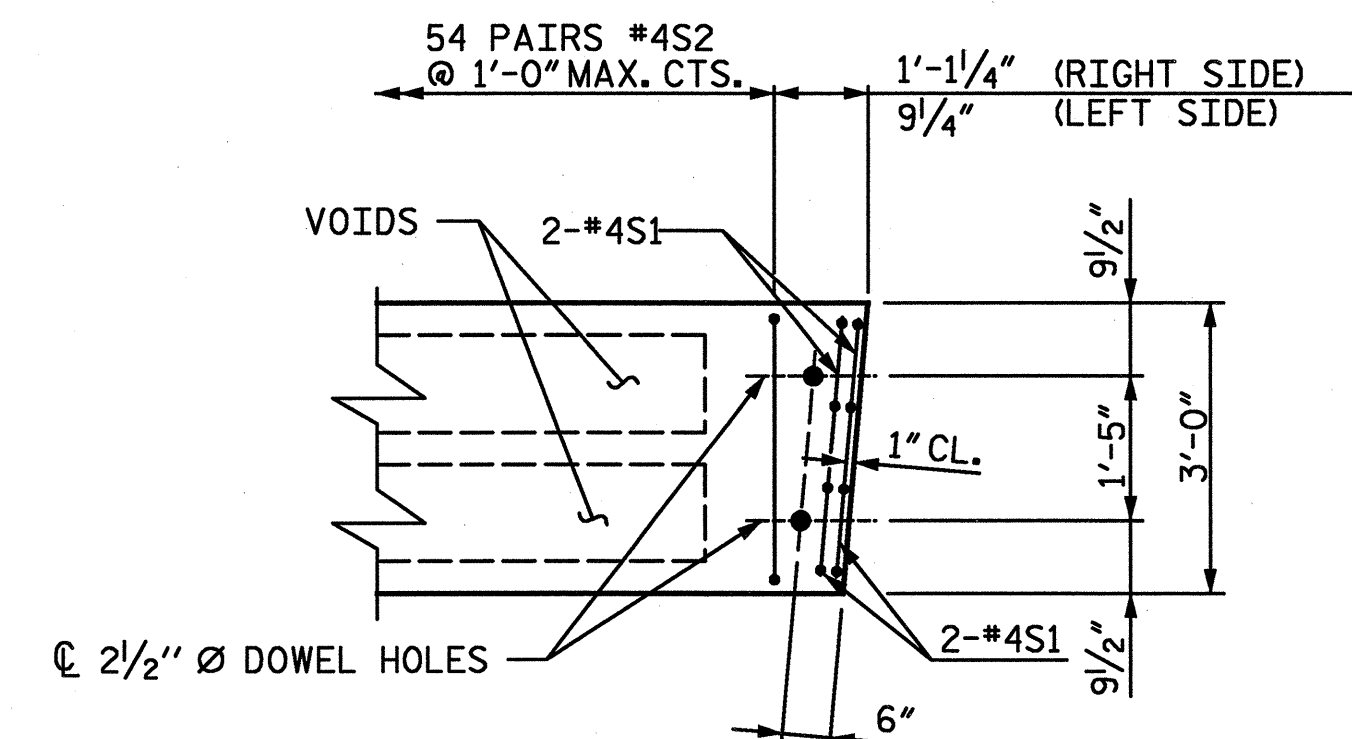

PART PLAN INTERIOR SLAB SECTION

(FAR END SHOWN, NEAR END SIMILAR BY SYMMETRY)

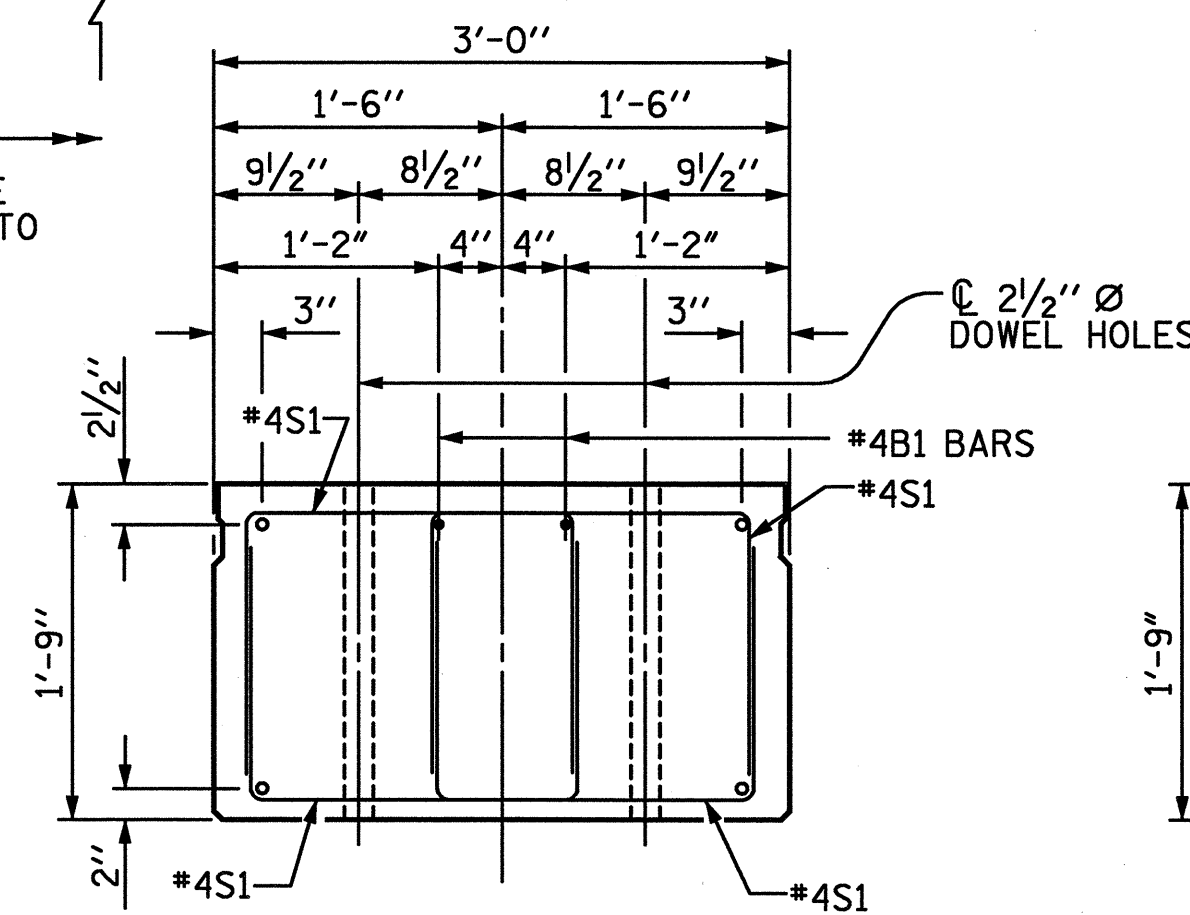

SLAB END ELEVATION

SHOWING PLACEMENT OF DOUBLE STIRRUPS AND LOCATION OF DOWEL HOLES.

INTERIOR SLAB SECTION SHOWN, EXTERIOR SLAB SECTION SIMILAR EXCEPT SHEAR KEY LOCATION.

STRAND LAYOUT NOT SHOWN.

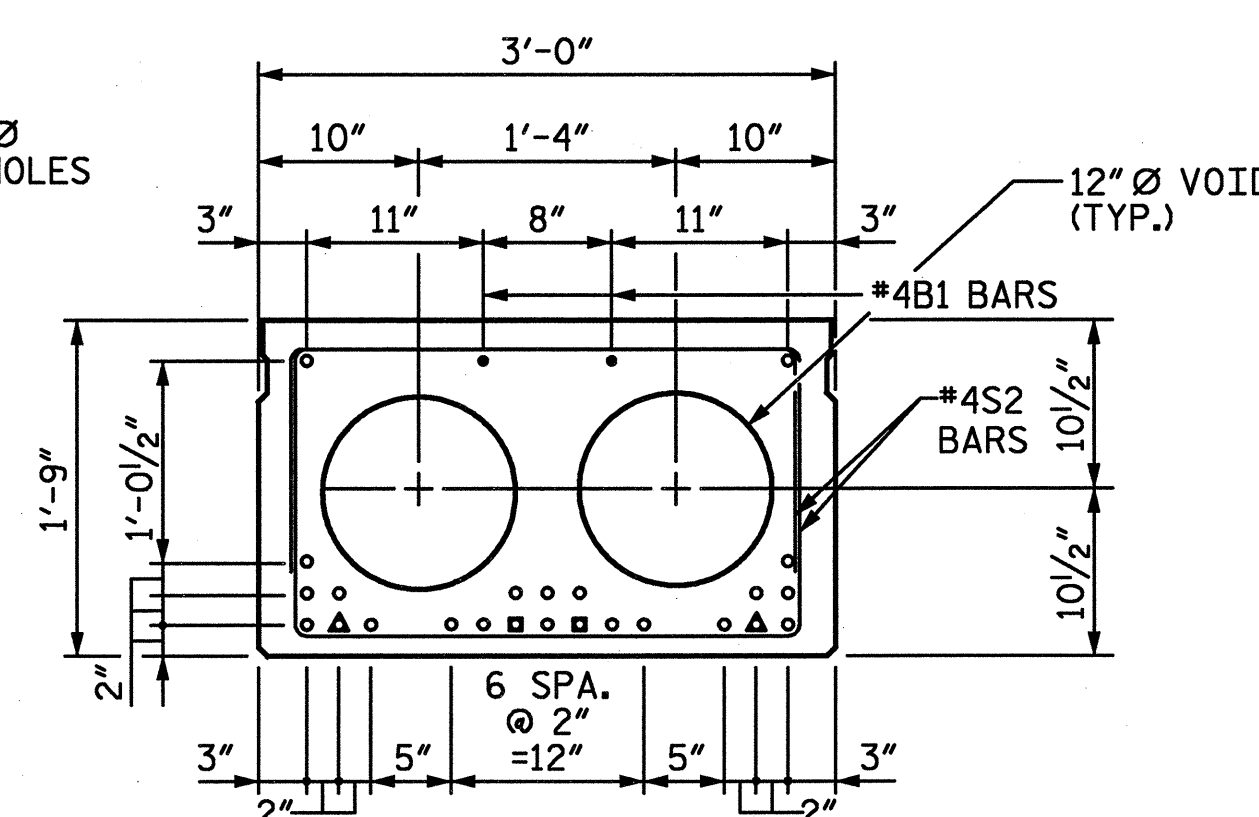

INTERIOR SLAB SECTION

(24 TOTAL STRANDS REQUIRED)

○ DENOTES 1/2" Ø L.R. STRANDS

▲ DENOTES SHEATHED STRAND. BOND SHALL BE BROKEN ON THESE STRANDS FOR A DISTANCE OF 4'-0" FROM END OF SLAB.

■ DENOTES SHEATHED STRAND. BOND SHALL BE BROKEN ON THESE STRANDS FOR A DISTANCE OF 6'-0" FROM END OF SLAB.

SEE STANDARD SPECIFICATIONS ARTICLE 1078-7.

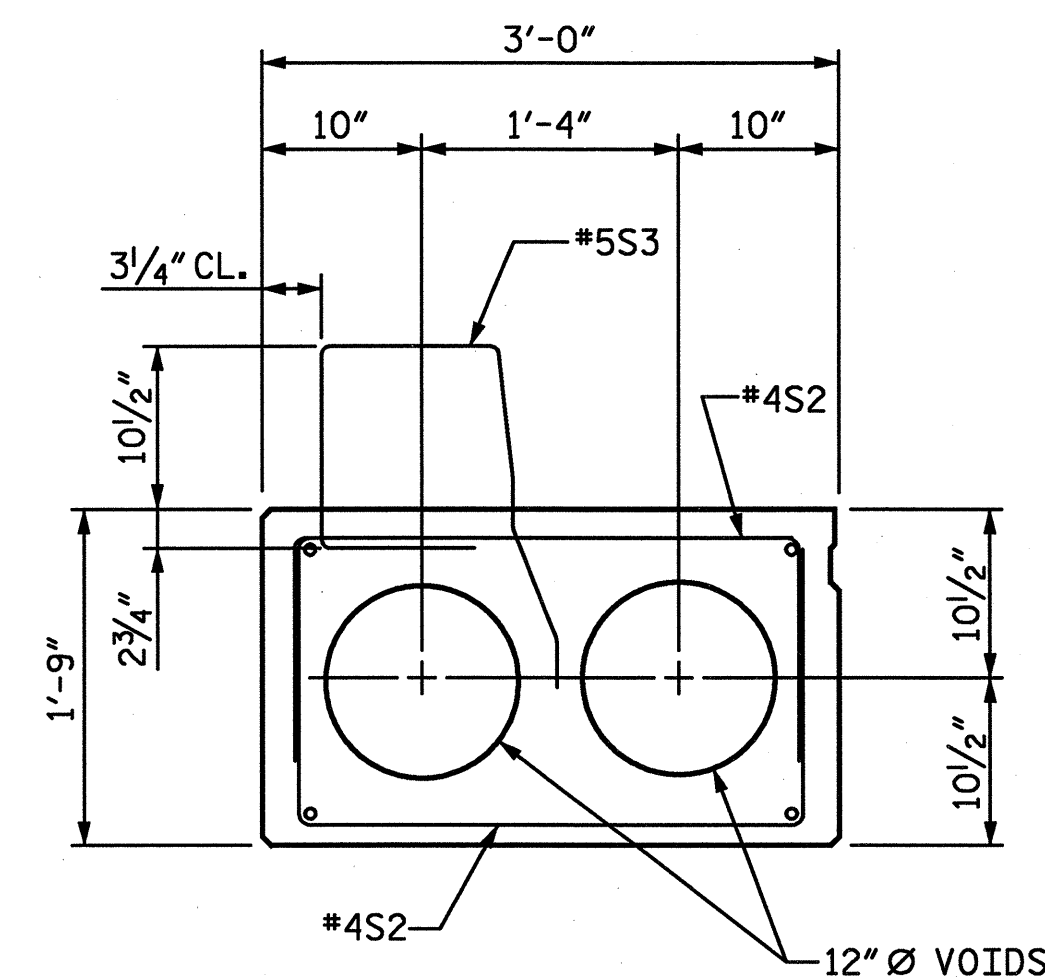

EXTERIOR SLAB SECTION

(FOR PRESTRESSED STRAND AND #4B1 BAR LAYOUT, SEE INTERIOR SLAB SECTION)

▲ NOTE: ASPHALT WEARING SURFACE IS INCLUDED IN THE QUANTITIES ON THE ROADWAY PLANS.

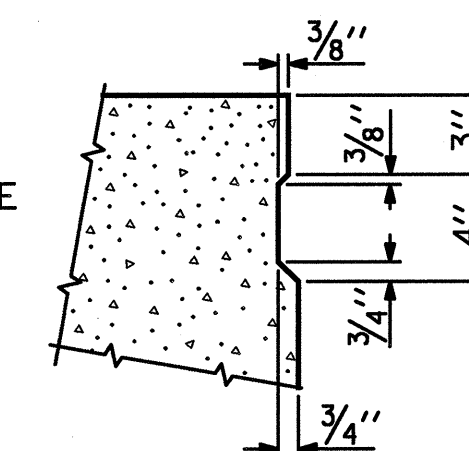

SHEAR KEY DETAIL

NOTE: OMIT SHEAR KEY ON OUTSIDE FACE OF EXTERIOR CORED SLAB

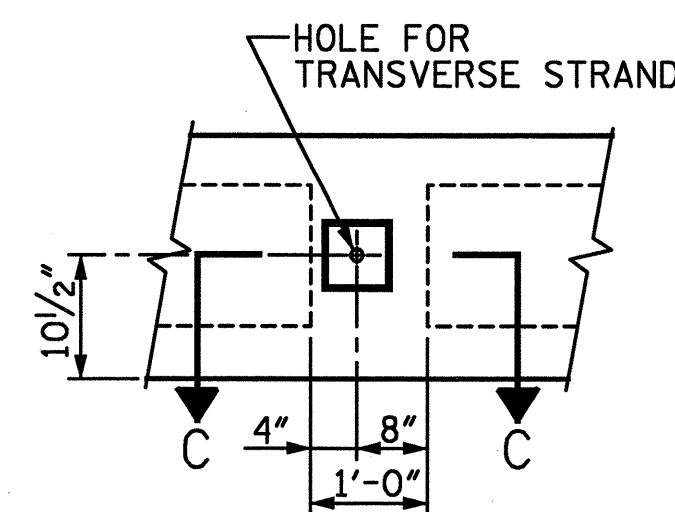

ELEVATION VIEW

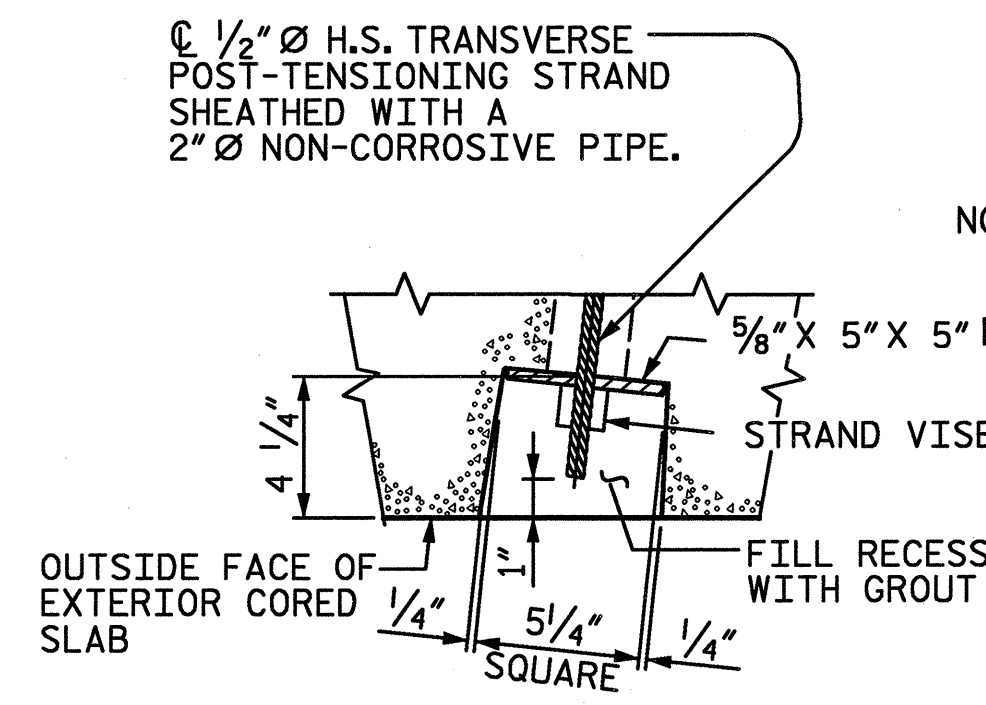

SECTION C-C

DETAIL A

GROUTED RECESS AT END OF POST-TENSIONED STRAND CORED SLABS

REVISION #1: REVISED PER REVIEW COMMENTS
BY: TJT DATE: 5-08
CHK'D BY: KGB DATE: 5-08

DRAWN BY: TRL DATE: 2-08
CHECKED BY: PEK DATE: 2-08

D-1809.55

STV/Ralph Whitehead Associates, Inc.
1000 West Morehead St., Ste. 200
Charlotte, NC 28208

PROJECT NO. B-5021
ROBESON COUNTY
BRIDGE: 169

SHEET 1 OF 4

STATE OF NORTH CAROLINA
DEPARTMENT OF TRANSPORTATION
RALEIGH

3'-0" X 1'-9"
PRESTRESSED
CORED SLAB

REVISIONS

NO.	BY:	DATE:	NO.	BY:	DATE:
1	STV	5-08	3		
2			4		

SHEET NO.
S-55
TOTAL SHEETS
62

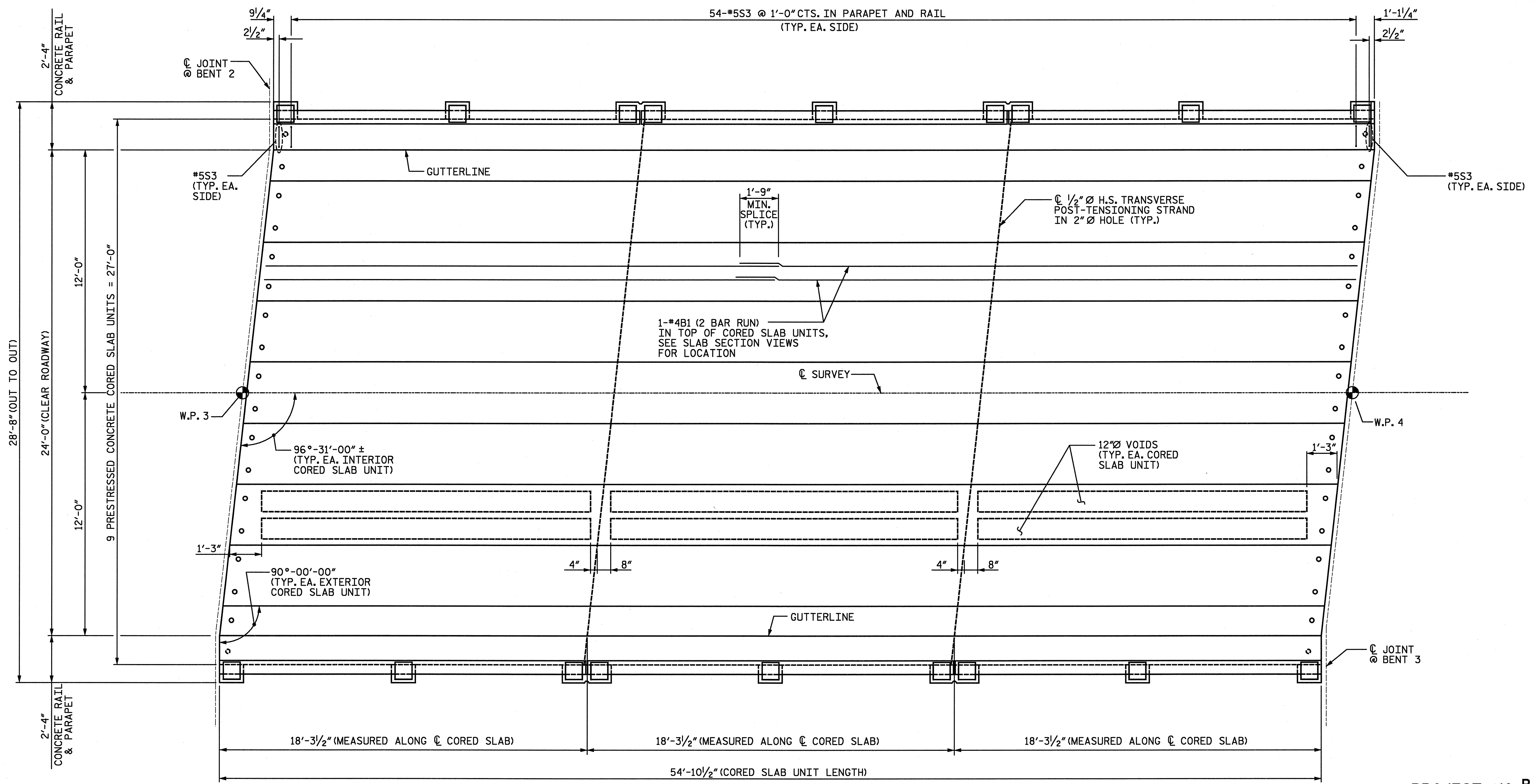

PLAN OF SPAN C

FOR ADDITIONAL CONCRETE RAIL REINFORCING STEEL
& DETAILS, SEE "CONCRETE BRIDGE RAIL" SHEET.

PROJECT NO. B-5021
ROBESON COUNTY

BRIDGE: 169

SHEET 2 OF 4

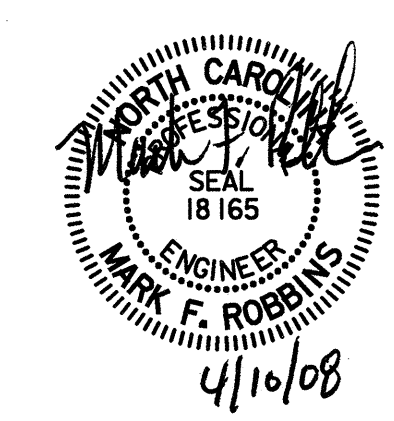
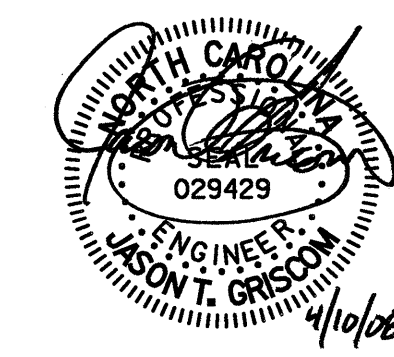

STATE OF NORTH CAROLINA
DEPARTMENT OF TRANSPORTATION
RALEIGH

**SUPERSTRUCTURE
PLAN OF SPAN C**

DRAWN BY : TRL DATE : 1-08
CHECKED BY : PEK DATE : 2-08

4/10/2008
N:\PROJ\2513448\B5021\Bridg 169\Station\Finals\Plan of Span C.dgn
+lmohv.townsend

D-1809.56
STV / Ralph Whitehead Associates, Inc.
1000 West Morehead St., Ste. 200
Charlotte, NC 28208

REVISIONS						SHEET NO.
NO.	BY:	DATE:	NO.	BY:	DATE:	TOTAL SHEETS
1			3			62
2			4			

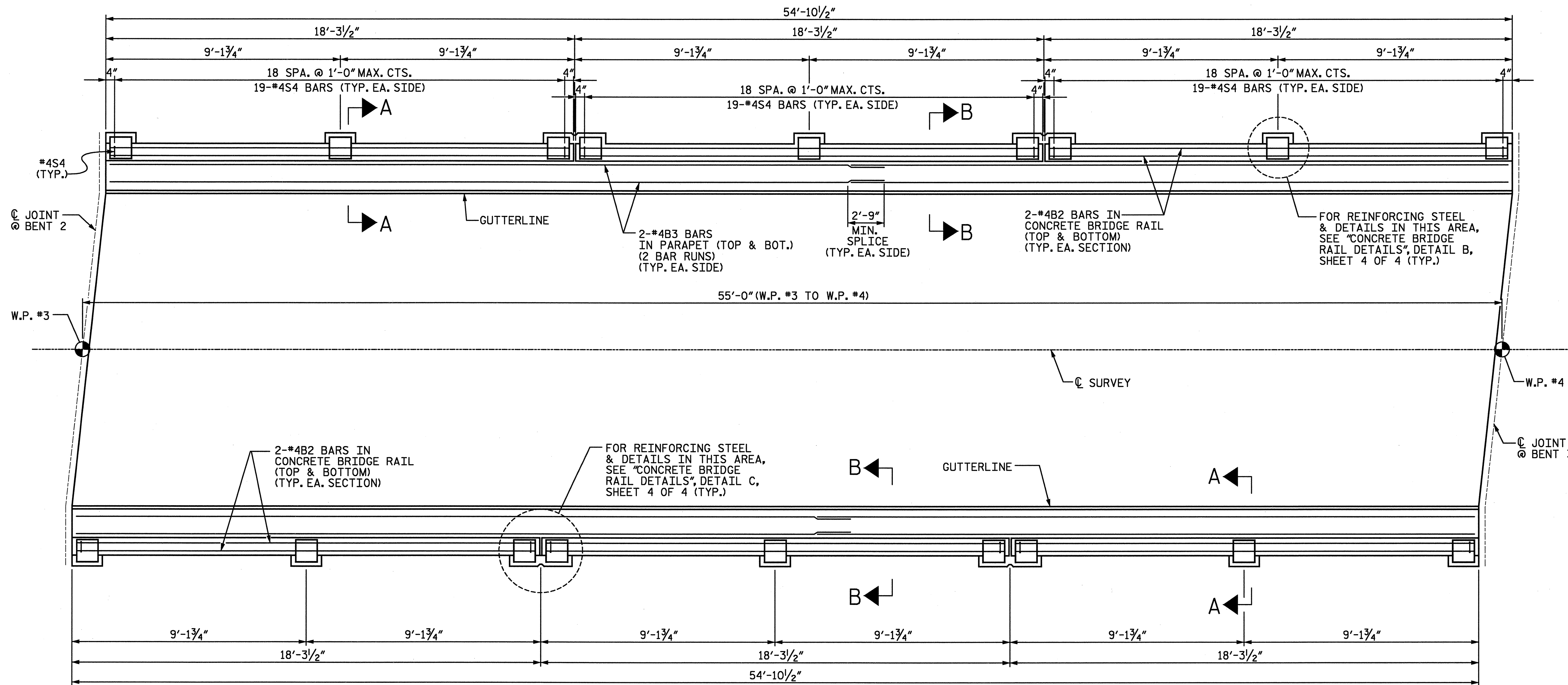

PLAN

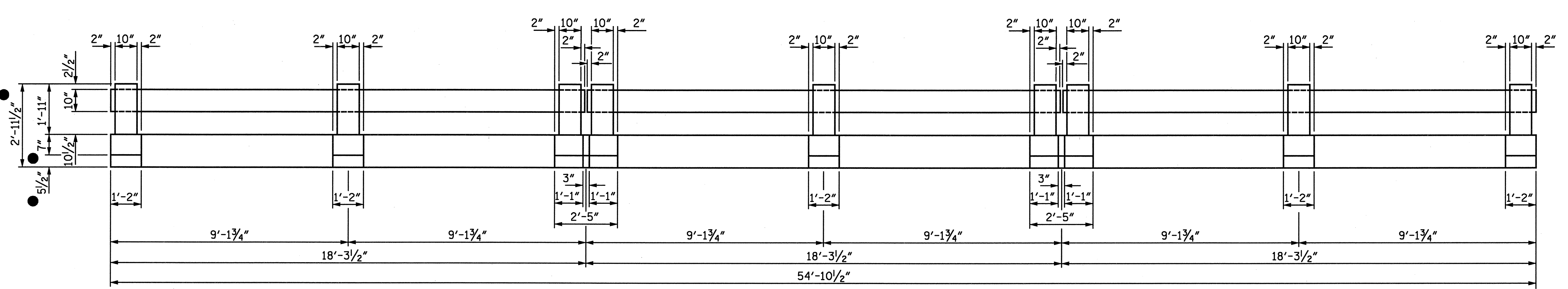

ELEVATION

(EXTERIOR OF RIGHT SIDE RAIL SHOWN, LEFT RAIL SIMILAR)

NOTE:
FOR SECTION VIEWS, SEE SHEET 4 OF 4.
CONCRETE BRIDGE RAIL SHALL BE CHAMFERED TO MATCH EXISTING RAIL.
FOR CONCRETE BRIDGE RAIL, SEE SPECIAL PROVISIONS.

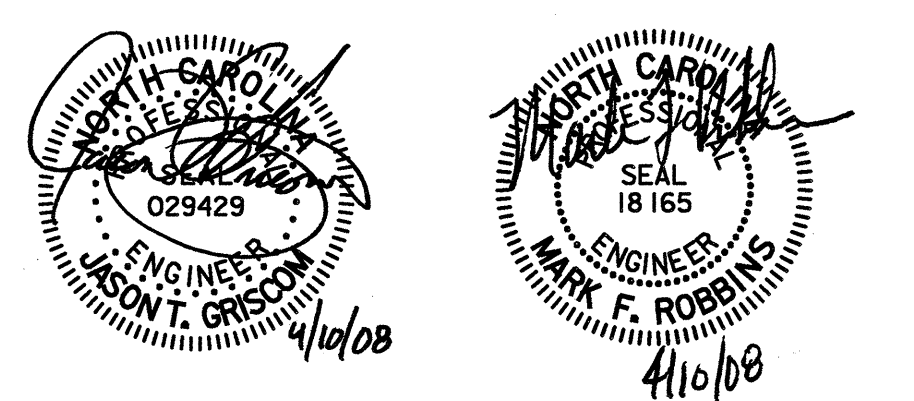

PROJECT NO. B-5021
ROBESON COUNTY
BRIDGE: 169
SHEET 3 OF 4

STATE OF NORTH CAROLINA
DEPARTMENT OF TRANSPORTATION
RALEIGH
SUPERSTRUCTURE
CONCRETE
BRIDGE RAIL

● DIMENSION MAY NEED TO BE ADJUSTED TO MATCH TOP OF RAIL IN ADJACENT SPANS. REINFORCING SHALL BE ADJUSTED TO MATCH THE REVISED RAIL HEIGHT.

DRAWN BY : TRL DATE : 1-08
CHECKED BY : PEK DATE : 2-08

D-1809.57
STV / Ralph Whitehead Associates, Inc.
1000 West Morehead St., Ste. 200
Charlotte, NC 28208

REVISIONS						SHEET NO.
NO.	BY:	DATE:	NO.	BY:	DATE:	S-57
1			3			TOTAL SHEETS
2			4			62

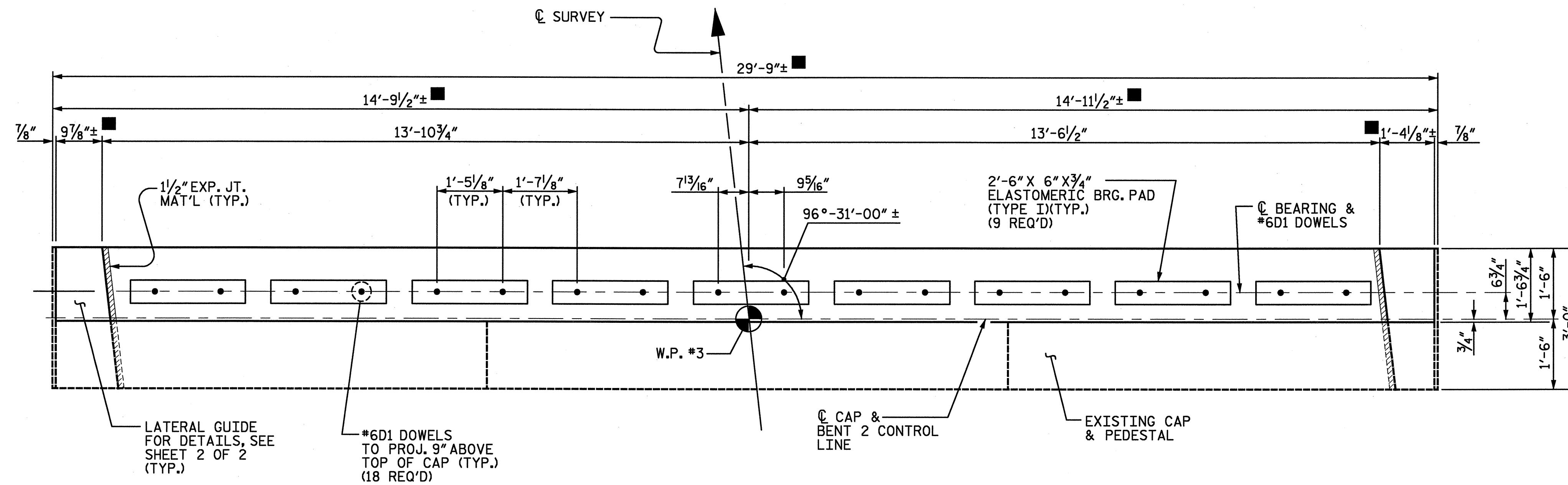

PLAN

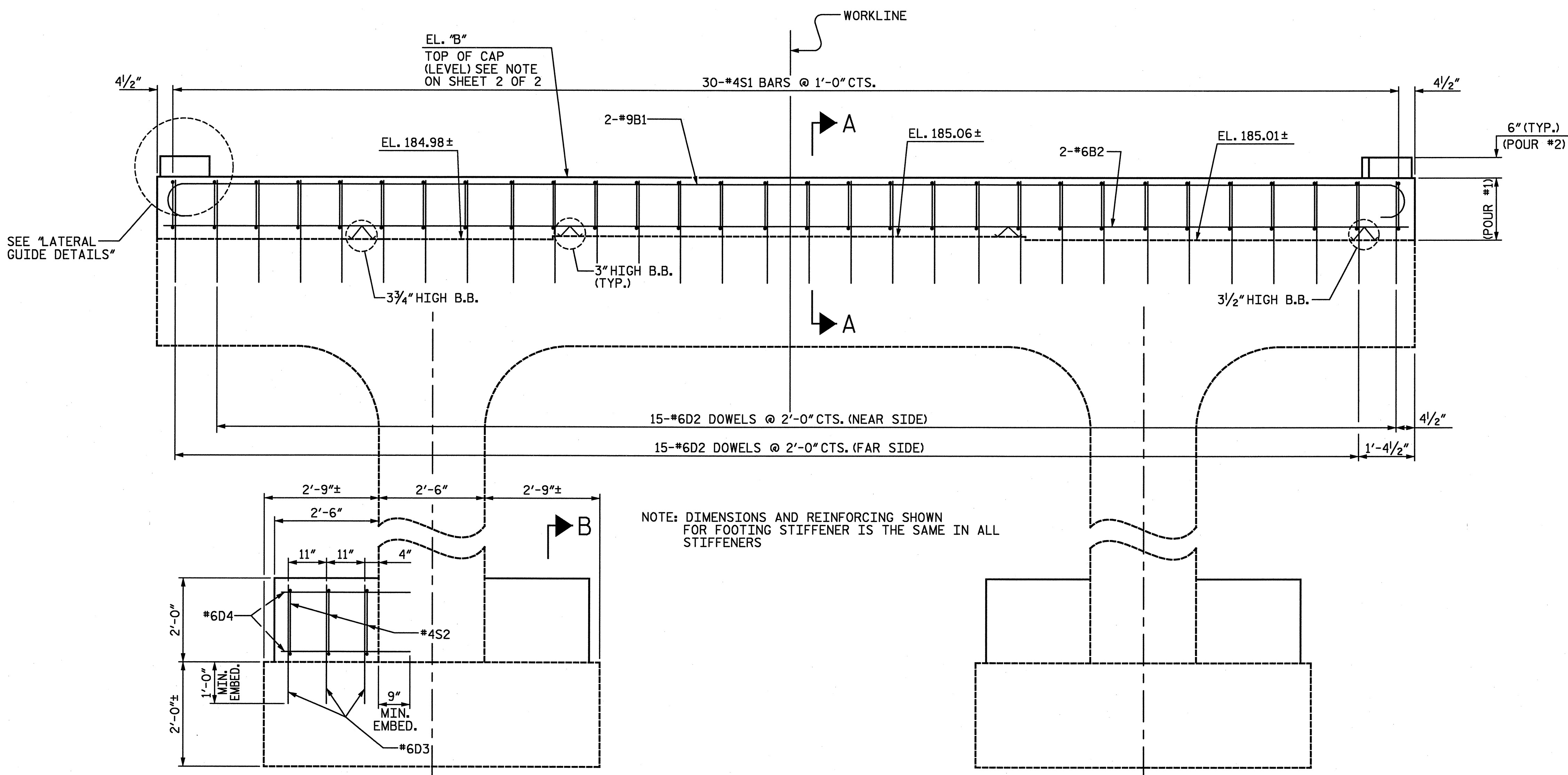

ELEVATION
(LOOKING UPSTATION)

NOTES

- REINFORCING STEEL MAY BE SHIFTED AS NECESSARY TO CLEAR DOWELS.
- THE LATERAL GUIDES ARE NOT TO BE POURED UNTIL AFTER THE CORED SLAB UNITS ARE IN PLACE.
- ALL ELEVATIONS ARE TO BE VERIFIED BY THE ENGINEER.
- A HIGH EARLY STRENGTH PORTLAND CEMENT CONCRETE SHALL BE USED TO ACHIEVE A MINIMUM COMPRESSIVE STRENGTH OF 5000 PSI PRIOR TO PLACING CORED SLAB UNITS. SEE STANDARD SPECIFICATION SECTION 1000 FOR DETAILS.
- *6D2, *6D3, AND *6D4 DOWELS SHALL BE ADHESIVELY ANCHORED USING AN APPROVED ADHESIVE CONSIDERING LOAD RESISTANCE, IN-SERVICE AND INSTALLATION TEMPERATURE, AVAILABILITY OF COMPREHENSIVE INSTALLATION INSTRUCTIONS, AND CREEP. ANCHORS SHALL BE INSTALLED TO THE MINIMUM EMBEDMENT DEPTHS AS SHOWN ON PLANS. LEVEL ONE FIELD TESTING IS REQUIRED, AND THE YIELD LOAD OF THE DOWEL IS 26 KIPS. FOR ADHESIVELY ANCHORED DOWELS, SEE SPECIAL PROVISIONS.
- DIMENSIONS AND ELEVATIONS ARE BASED ON AS-BUILT DIMENSIONS AND FIELD SURVEY INFORMATION. CONTRACTOR SHALL FIELD VERIFY DIMENSIONS PRIOR TO CONSTRUCTION. REINFORCING AND CONCRETE CAP EXTENSIONS SHALL BE ADJUSTED TO MATCH FIELD VERIFIED DIMENSIONS PROVIDED THAT THE OUT-TO-OUT DIMENSIONS REMAIN AS DETAILED.

NOTE: DIMENSIONS AND REINFORCING SHOWN FOR FOOTING STIFFENER IS THE SAME IN ALL STIFFENERS

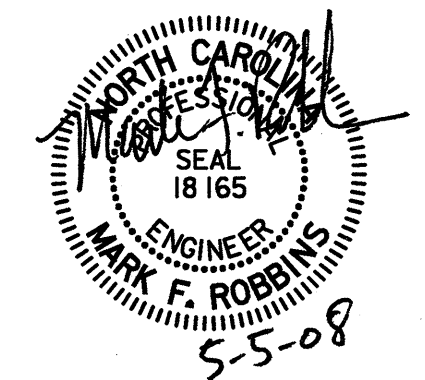
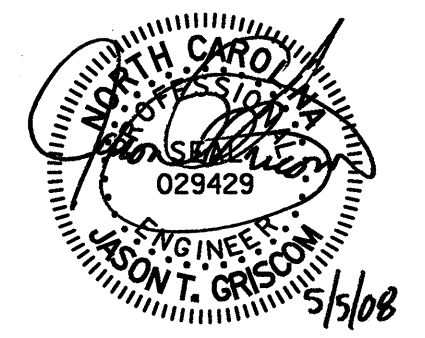

PROJECT NO. **B-5021**
ROBESON COUNTY
 BRIDGE: **169**

SHEET 1 OF 2

STATE OF NORTH CAROLINA
 DEPARTMENT OF TRANSPORTATION
 RALEIGH
 SUBSTRUCTURE
 BENT 2

DRAWN BY: TRL DATE: 1-08
 CHECKED BY: PEK DATE: 2-08

REVISION #1: REVISED PER REVIEW COMMENTS
 BY: TJT DATE: 5-08
 CH'KD BY: KGB DATE: 5-08

D-1809.59
 STV / Ralph Whitehead Associates, Inc.
 1000 West Morehead St., Ste. 200
 Charlotte, NC 28208

REVISIONS					SHEET NO.
NO.	BY:	DATE:	NO.	BY:	DATE:
1	STV	5-08	3		
2			4		

TOTAL SHEETS: 62

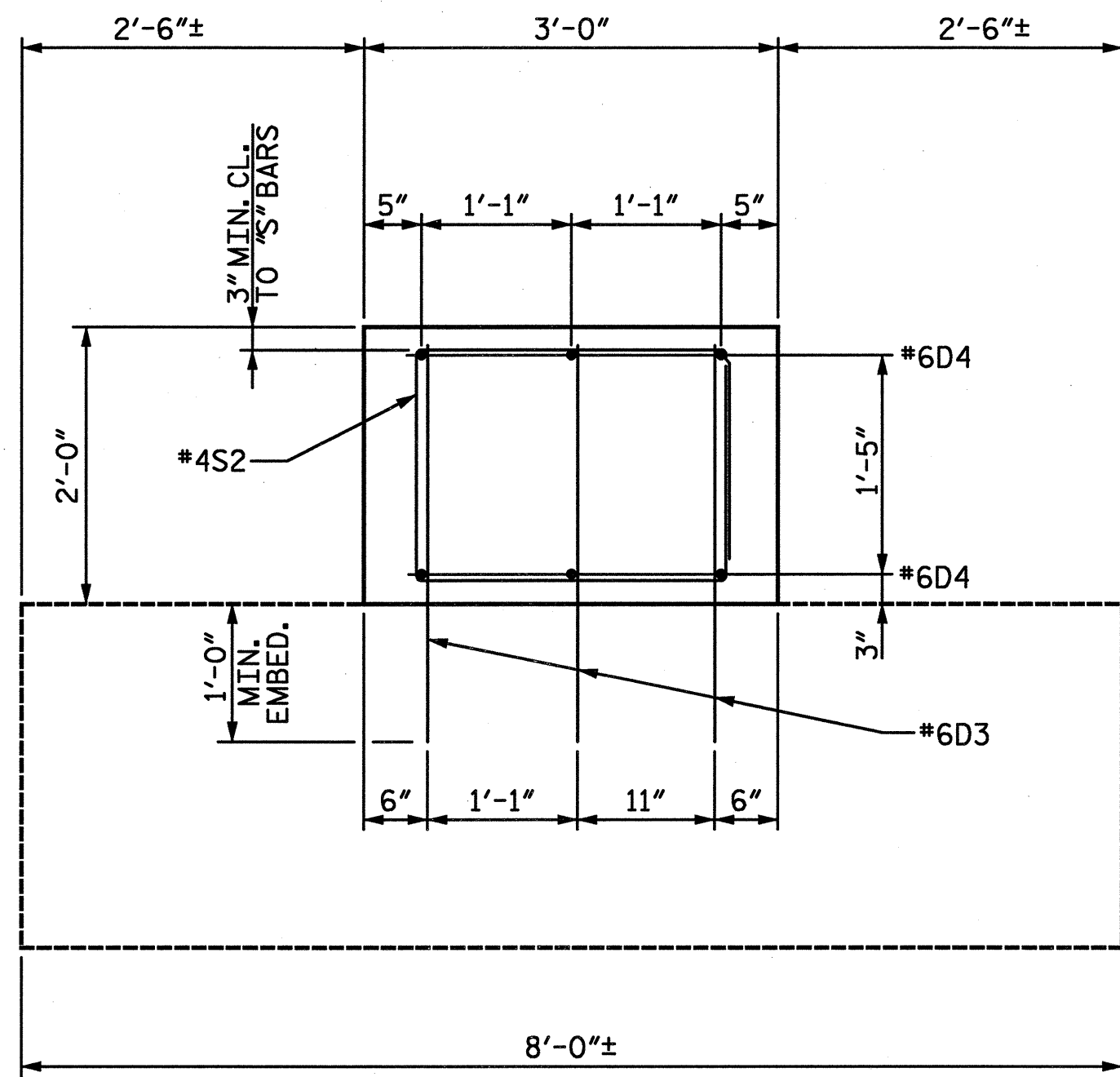

SECTION B-B

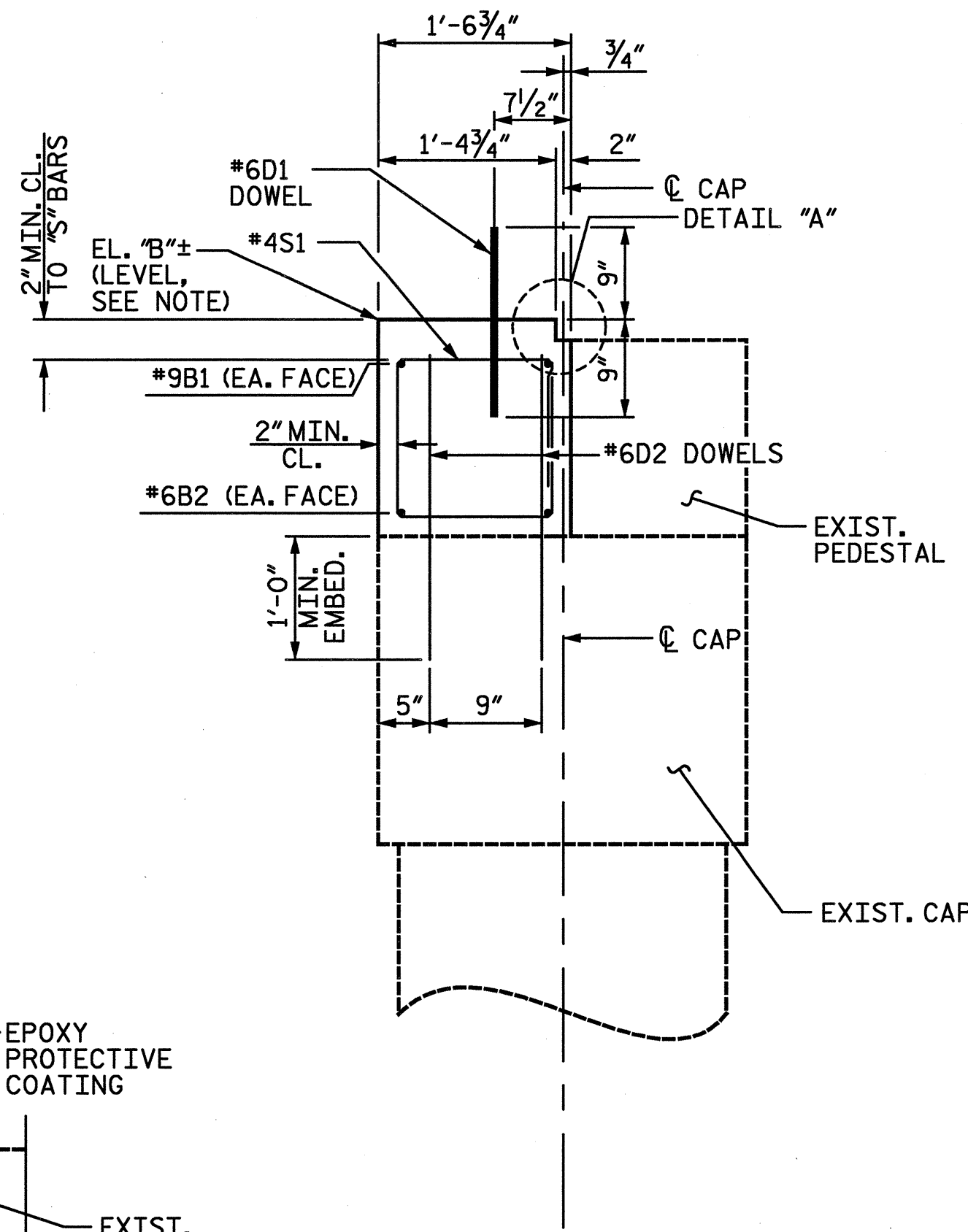

SECTION A-A

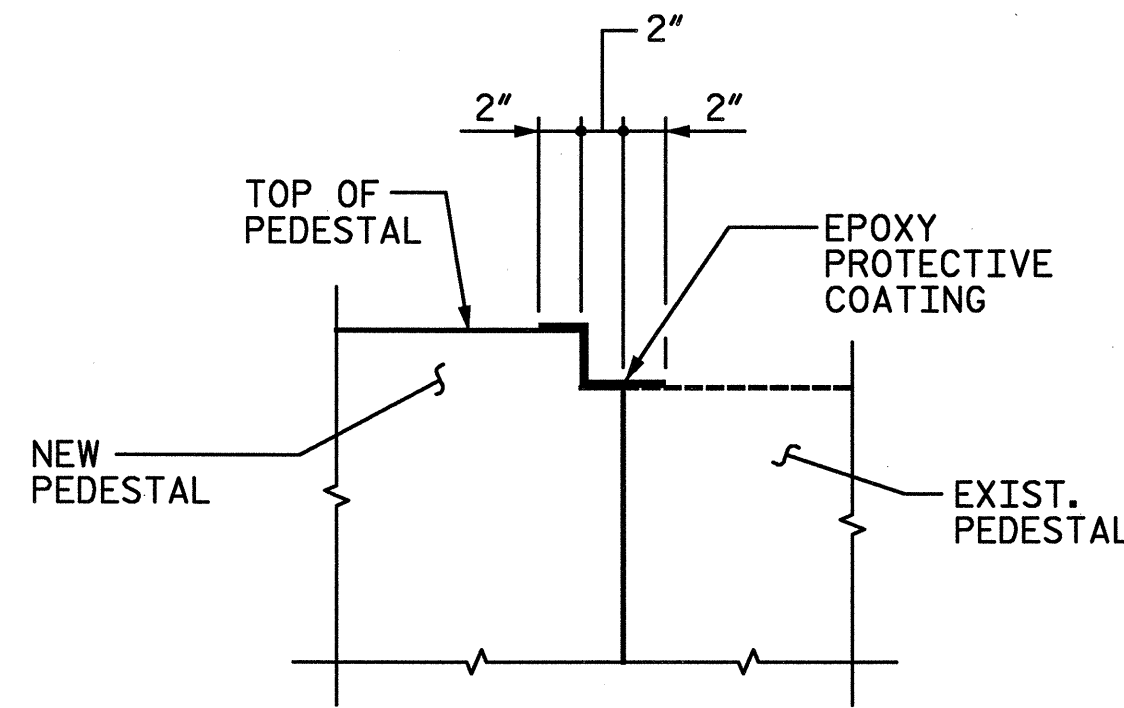

DETAIL "A"

NOTE: THE TOP SURFACES OF THE NEW AND EXISTING PEDESTAL SHALL BE CURED A MINIMUM OF 2" FROM THE COLD JOINT IN ACCORDANCE WITH THE STANDARD SPECIFICATIONS EXCEPT THE MEMBRANE CURING COMPOUND METHOD SHALL NOT BE USED.

BAR TYPES		BILL OF MATERIAL				
		BENT 2				
BAR	NO.	SIZE	TYPE	LENGTH	WEIGHT	
B1	2	9	①	31'-9"	216	
B2	2	6	STR.	29'-3"	88	
D1	18	6	STR.	1'-6"	41	
D2	30	6	STR.	2'-0"	90	
D3	36	6	STR.	2'-9"	149	
D4	24	6	STR.	3'-0"	108	
S1	30	4	②	5'-4"	107	
S2	12	4	②	9'-4"	75	
U1	4	4	③	4'-0"	11	
REINFORCING STEEL				LBS.	885	
CLASS AA CONCRETE BREAKDOWN						
POUR 1 (CAP & FOOTING) CY					5.6	
POUR 2 (LATERAL GUIDE) CY					0.1	
TOTAL				CY	5.7	

ALL BAR DIMENSIONS ARE OUT TO OUT

NOTE: DIMENSIONS AND ELEVATIONS SHOWN ARE FROM BEST INFORMATION AVAILABLE. CONTRACTOR SHALL MAKE ADJUSTMENTS TO PEDESTAL EL. "B" TO MAINTAIN 3/2" (4 1/2" MAX.) ASPHALT WEARING SURFACE @ C BEARING, MATCH EL. "D", AND TO MAINTAIN THE 16'-0" MIN. VERTICAL CLEARANCE. IF ANY ELEVATIONS ARE MODIFIED, THE CONTRACTOR IS RESPONSIBLE FOR ADJUSTING THE REINFORCING TO FIT THE PEDESTAL HEIGHT.

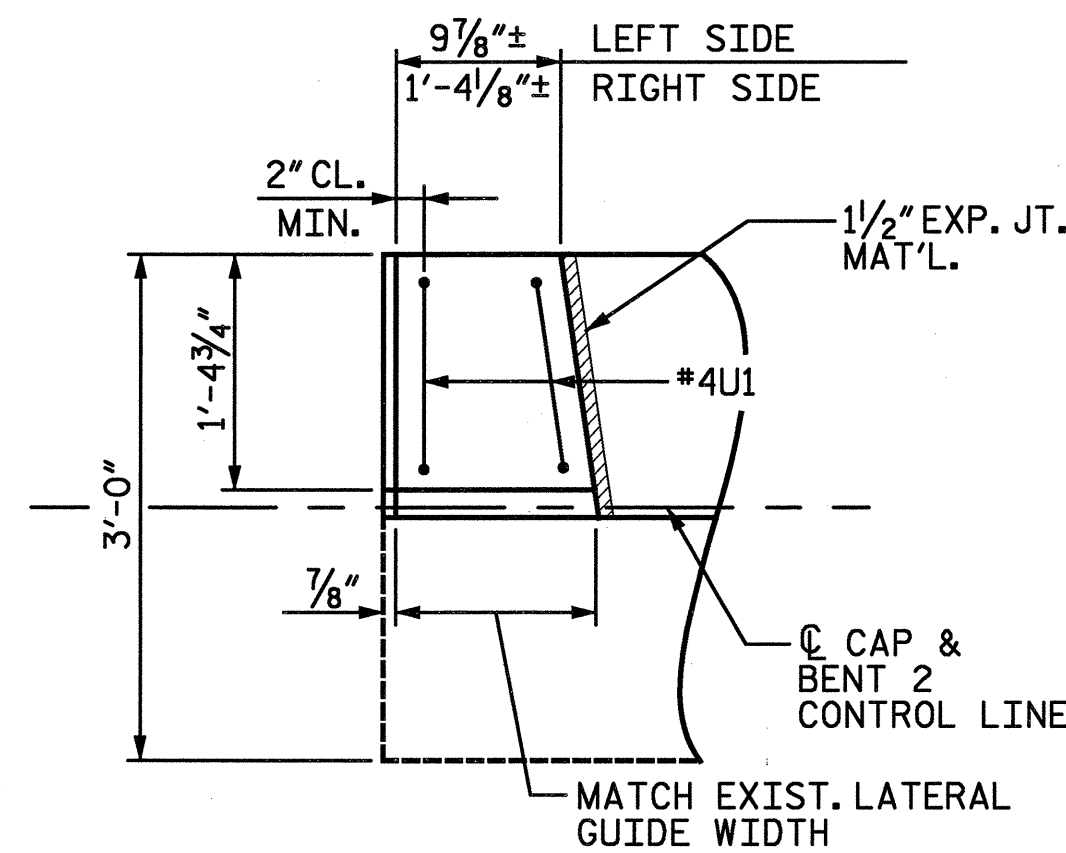

PLAN

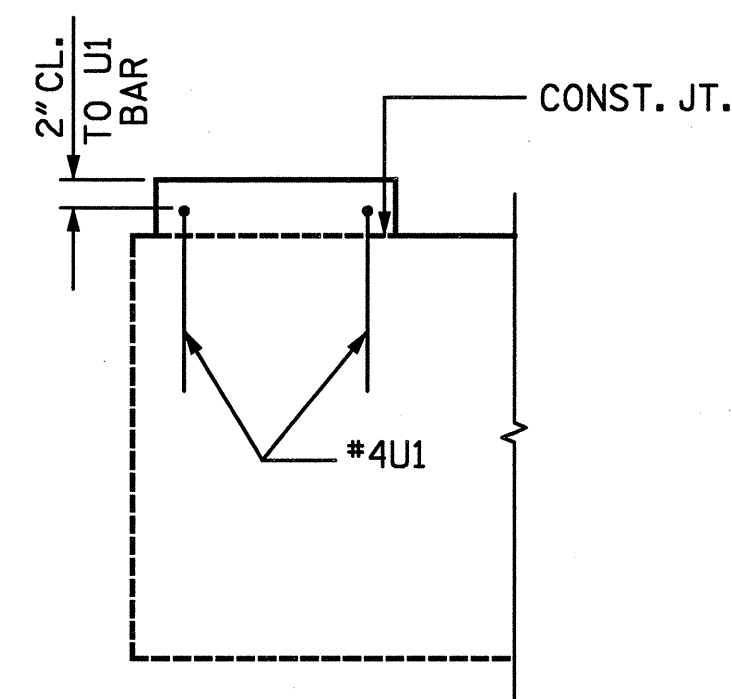

ELEVATION

LATERAL GUIDE DETAILS

(LEFT SIDE SHOWN, RIGHT SIDE SIMILAR)

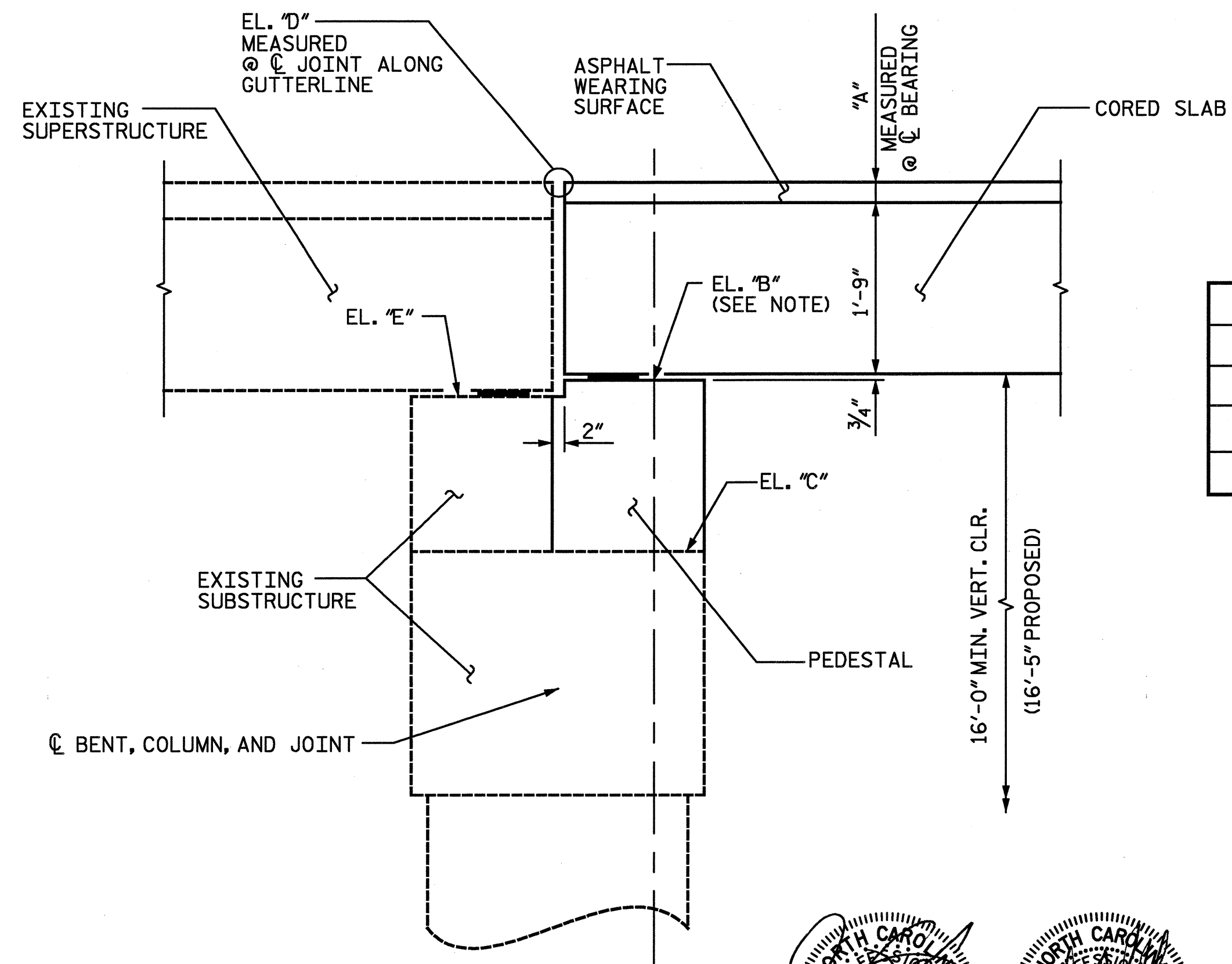

PEDESTAL HEIGHT

"A"	3 1/2"
"B"	186.89
"C"	185.16
"D"	188.99
"E"	186.66

PROJECT NO. B-5021
ROBESON COUNTY

BRIDGE: 169

SHEET 2 OF 2

STATE OF NORTH CAROLINA
DEPARTMENT OF TRANSPORTATION
RALEIGH

SUBSTRUCTURE
BENT 2

REVISIONS				SHEET NO.
NO.	BY:	DATE:	NO.	DATE:
1			3	
2			4	

S-60
TOTAL SHEETS
62

DRAWN BY: TRL DATE: 1-08
CHECKED BY: PEK DATE: 2-08

D-1809.60

STV / Ralph Whitehead Associates, Inc.
1000 West Morehead St., Ste. 200
Charlotte, NC 28208

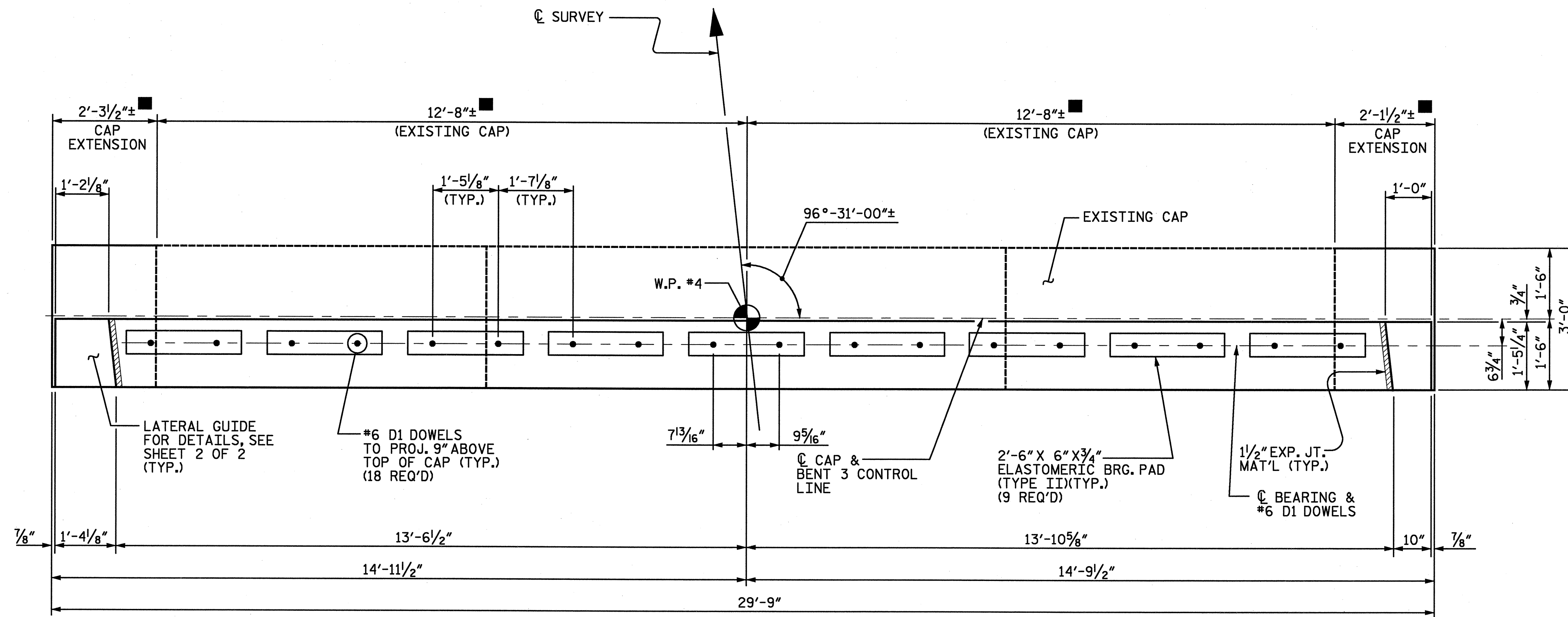

NOTES

- REINFORCING STEEL MAY BE SHIFTED AS NECESSARY TO CLEAR DOWELS.
- THE LATERAL GUIDES ARE NOT TO BE POURED UNTIL AFTER THE CORED SLAB UNITS ARE IN PLACE.
- ALL ELEVATIONS ARE TO BE VERIFIED BY THE ENGINEER.
- A HIGH EARLY STRENGTH PORTLAND CEMENT CONCRETE SHALL BE USED TO ACHIEVE A MINIMUM COMPRESSIVE STRENGTH OF 5000 PSI PRIOR TO PLACING CORED SLAB UNITS. SEE STANDARD SPECIFICATION SECTION 1000 FOR DETAILS.
- #6D2 & #6U2 DOWELS SHALL BE ADHESIVELY ANCHORED USING AN APPROVED ADHESIVE CONSIDERING LOAD RESISTANCE, IN-SERVICE AND INSTALLATION TEMPERATURE, AVAILABILITY OF COMPREHENSIVE INSTALLATION INSTRUCTIONS, AND CREEP. ANCHORS SHALL BE INSTALLED TO THE MINIMUM EMBEDMENT DEPTHS AS SHOWN ON PLANS. LEVEL ONE FIELD TESTING IS REQUIRED, AND THE YIELD LOAD OF THE DOWEL IS 26 KIPS. FOR ADHESIVELY ANCHORED DOWELS, SEE SPECIAL PROVISIONS.
- DIMENSIONS AND ELEVATIONS ARE BASED ON AS-BUILT DIMENSIONS AND FIELD SURVEY INFORMATION. CONTRACTOR SHALL FIELD VERIFY DIMENSIONS PRIOR TO CONSTRUCTION. REINFORCING AND CONCRETE CAP EXTENSIONS SHALL BE ADJUSTED TO MATCH FIELD VERIFIED DIMENSIONS PROVIDED THAT THE OUT-TO-OUT DIMENSIONS REMAIN AS DETAILED.

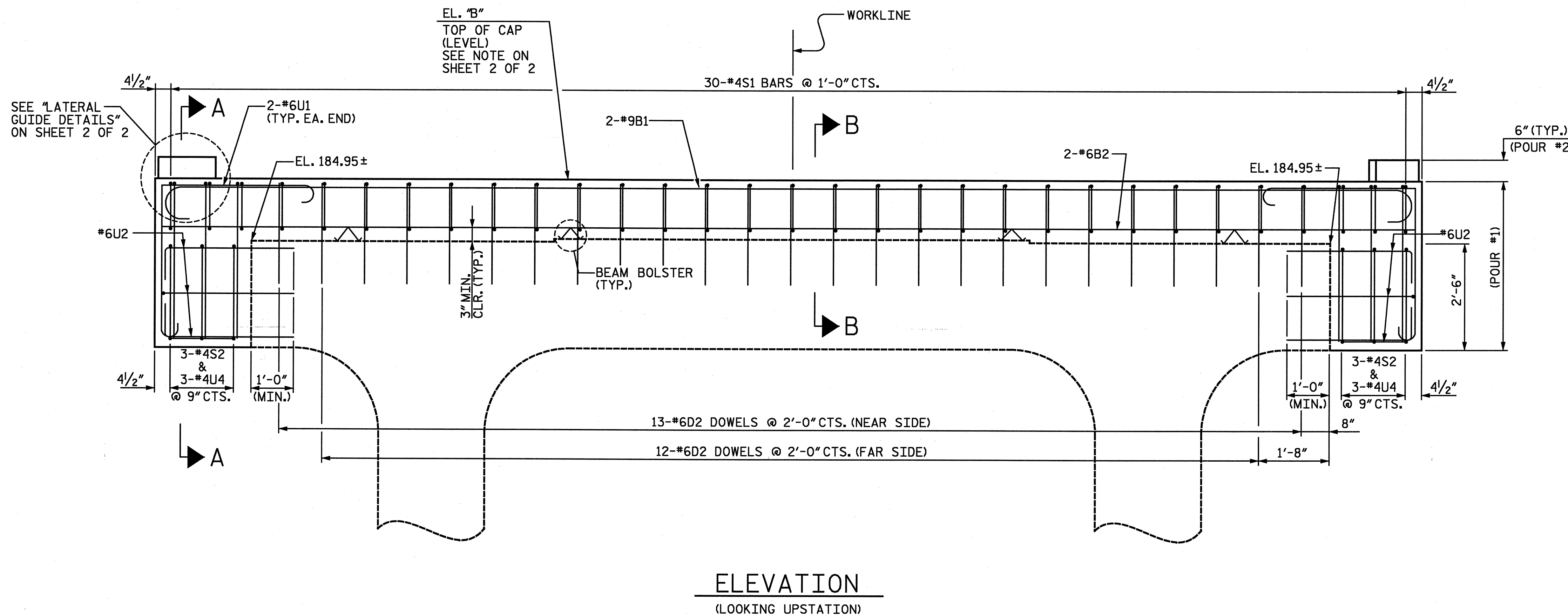

PROJECT NO. B-5021
 ROBESON COUNTY

BRIDGE: 169

SHEET 1 OF 2

STATE OF NORTH CAROLINA
 DEPARTMENT OF TRANSPORTATION
 RALEIGH

SUBSTRUCTURE
 BENT 3

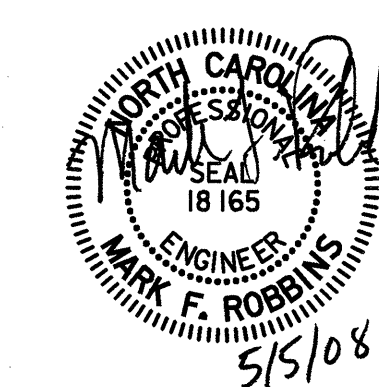
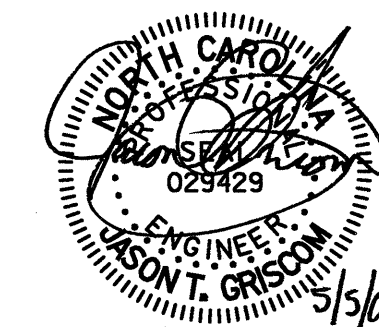

REVISION #1: REVISED PER REVIEW COMMENTS
 BY: TJT DATE: 5-08
 CH'KD BY: KGB DATE: 5-08

D-1809.61

STV / Ralph Whitehead Associates, Inc.
 1000 West Morehead St., Ste. 200
 Charlotte, NC 28208

REVISIONS						SHEET NO.
NO.	BY	DATE	NO.	BY	DATE	TOTAL SHEETS
1	STV	5-08	3			61
2			4			62

DRAWN BY: TRL DATE: 1-08
 CHECKED BY: PEK DATE: 2-08

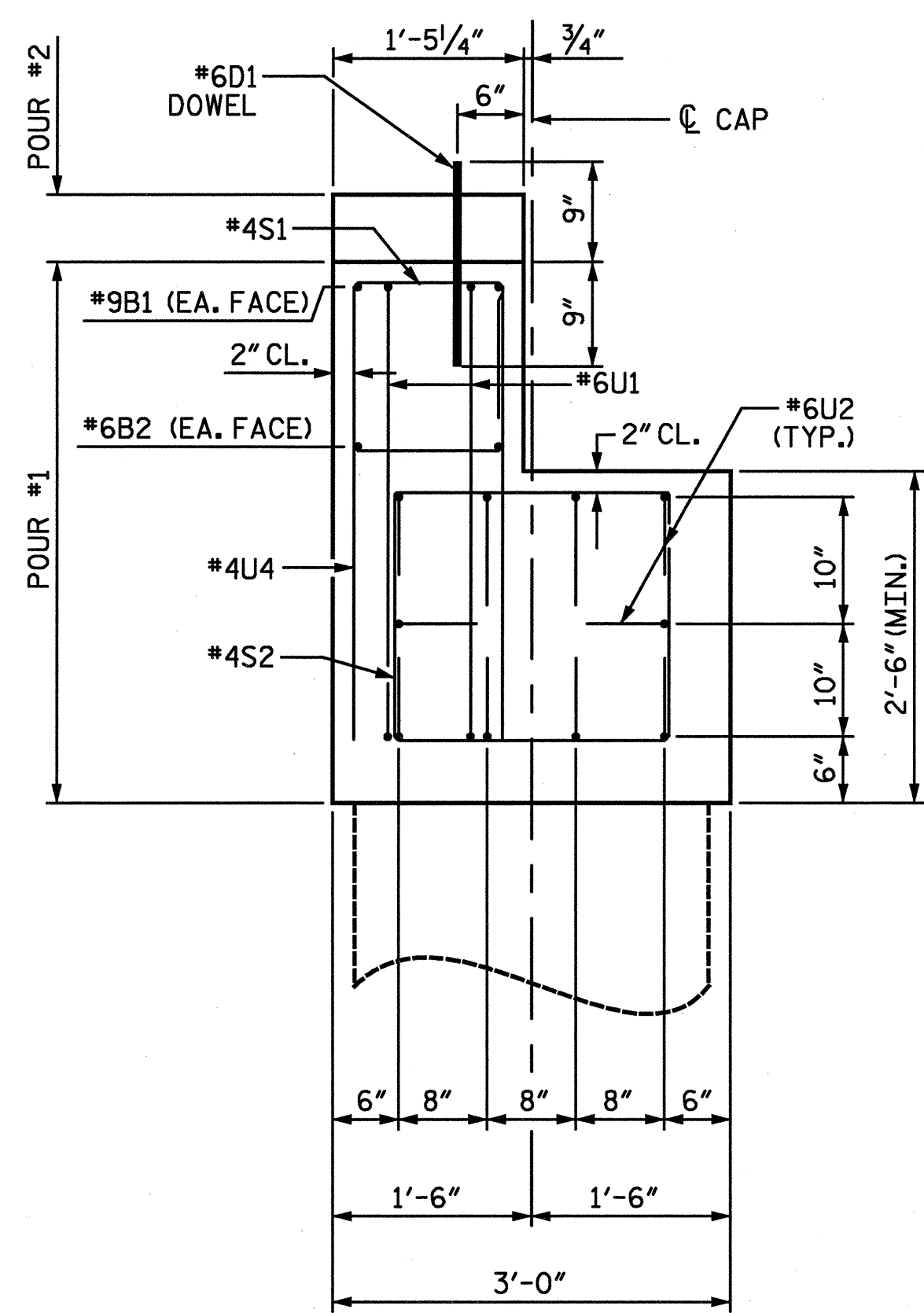

SECTION A-A

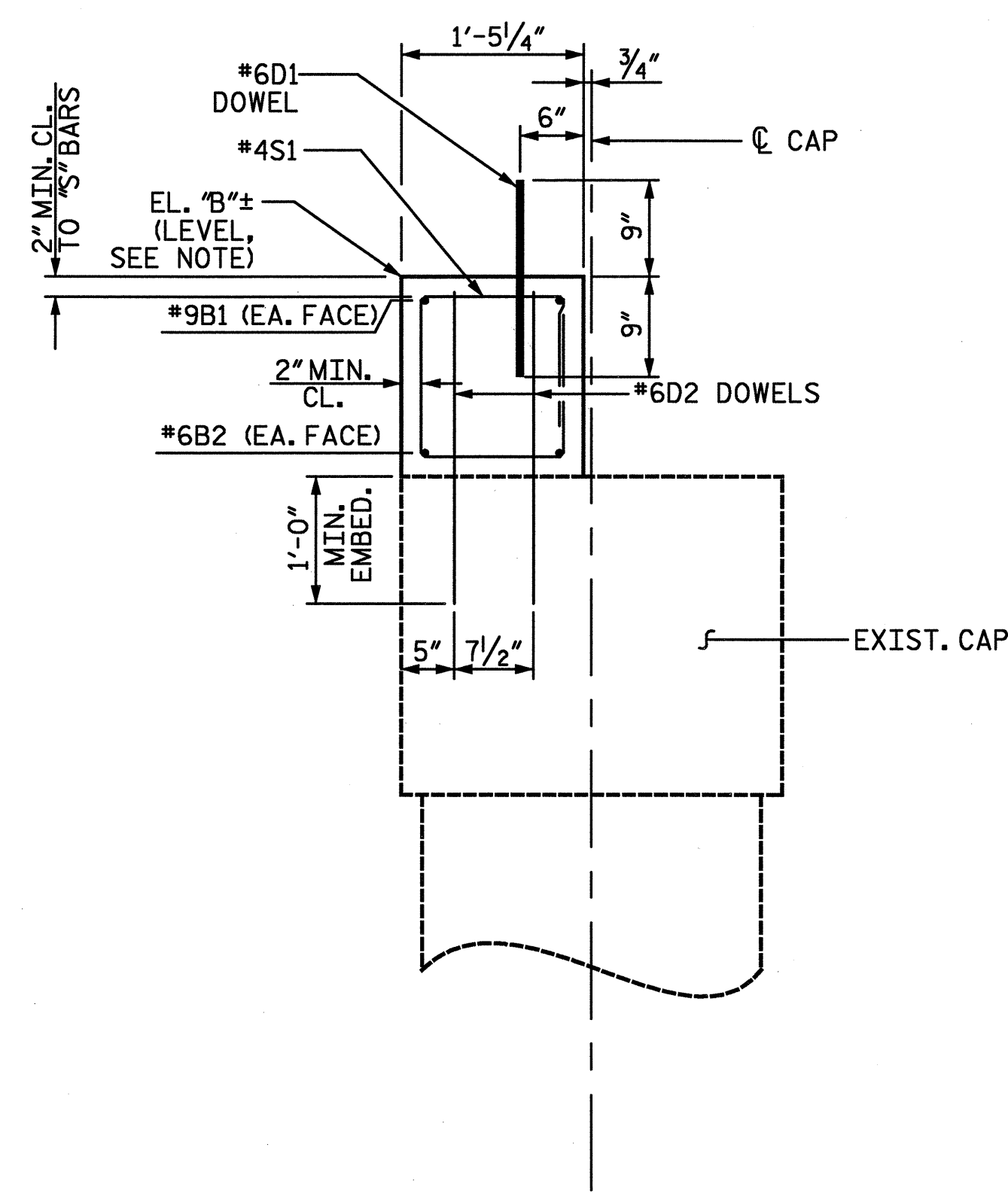

SECTION B-B

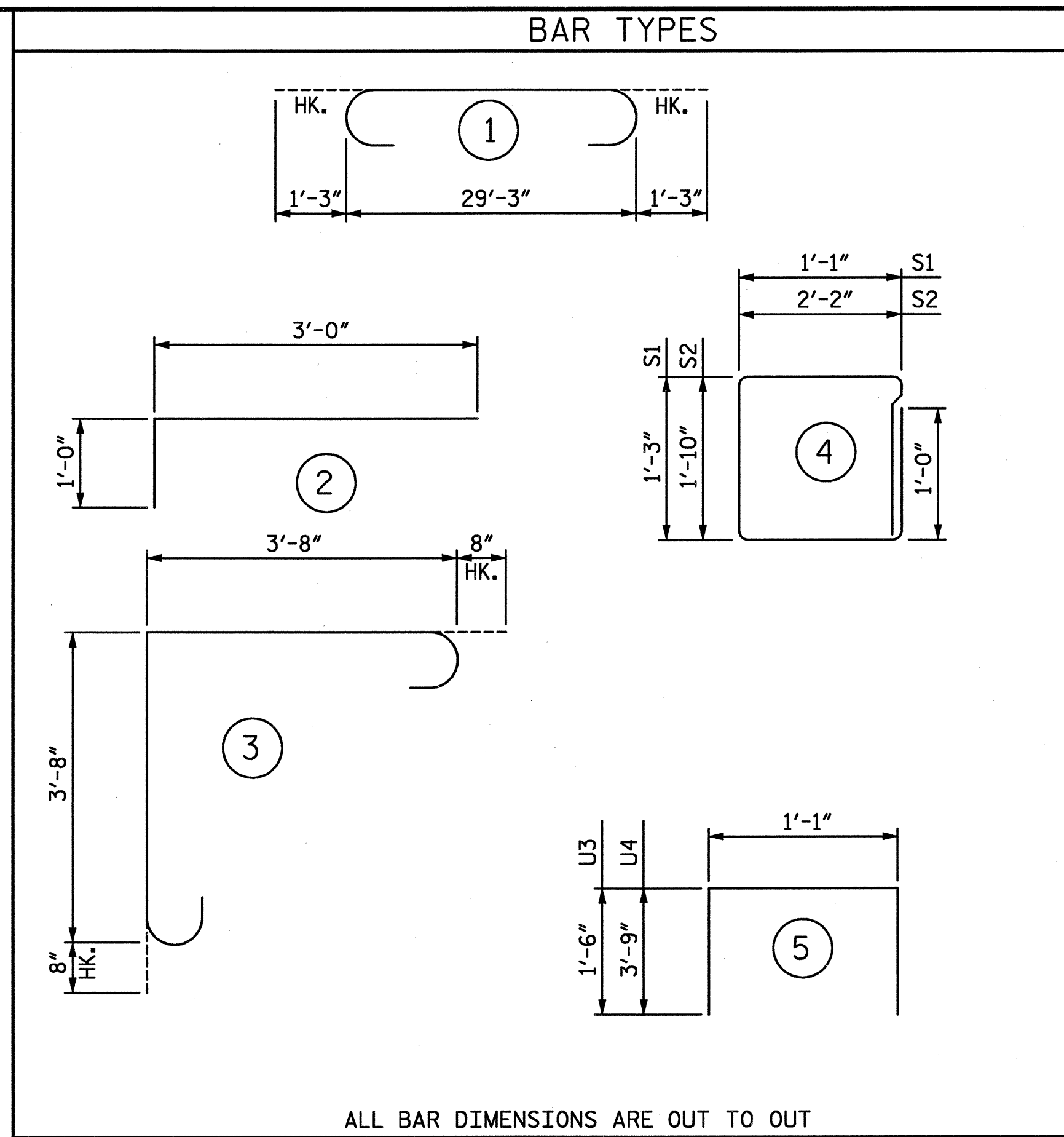

ALL BAR DIMENSIONS ARE OUT TO OUT

BILL OF MATERIAL					
BENT 3					
BAR	NO.	SIZE	TYPE	LENGTH	WEIGHT
B1	2	9	①	31'-9"	216
B2	2	6	STR.	29'-3"	88
D1	18	6	STR.	1'-6"	41
D2	25	6	STR.	2'-0"	75
S1	30	4	④	5'-8"	114
S2	6	4	④	9'-0"	36
U1	4	6	③	8'-8"	52
U2	20	6	②	4'-0"	120
U3	4	4	⑤	4'-1"	11
U4	6	4	⑤	8'-7"	34
REINFORCING STEEL				LBS.	787
CLASS AA CONCRETE BREAKDOWN					
POUR 1 (CAP)				CY	4.1
POUR 2 (LATERAL GUIDE) CY					0.1
TOTAL				CY	4.2

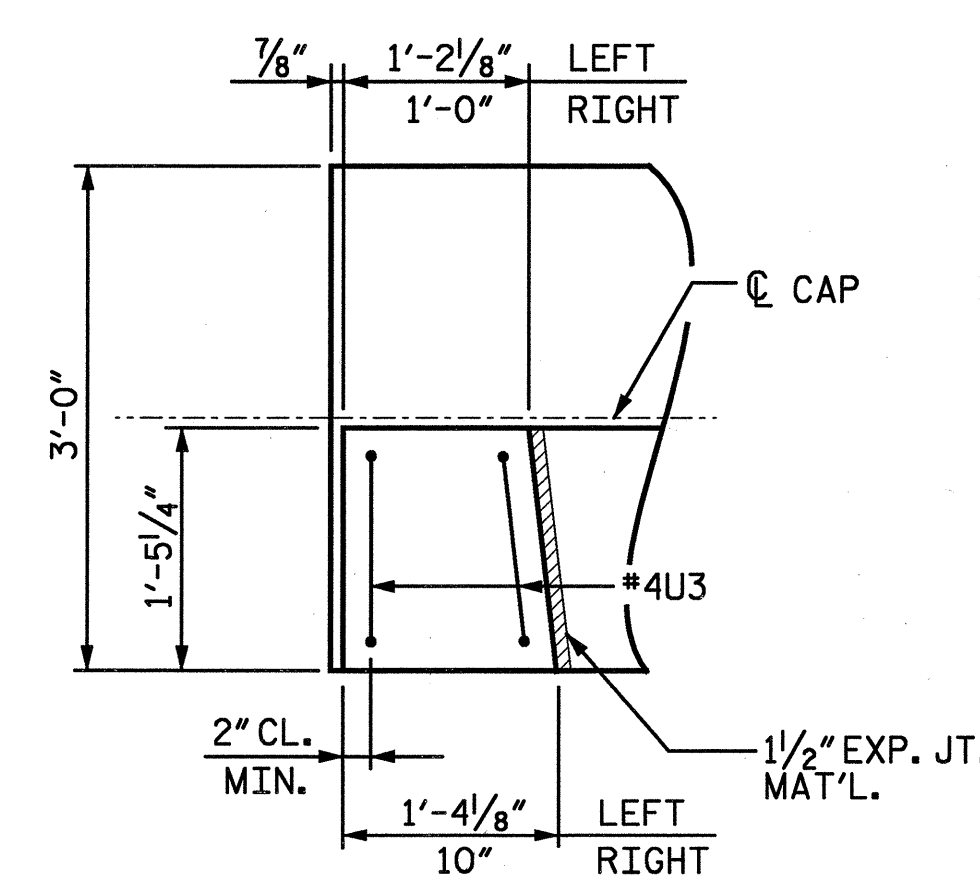

PLAN

LATERAL GUIDE DETAILS

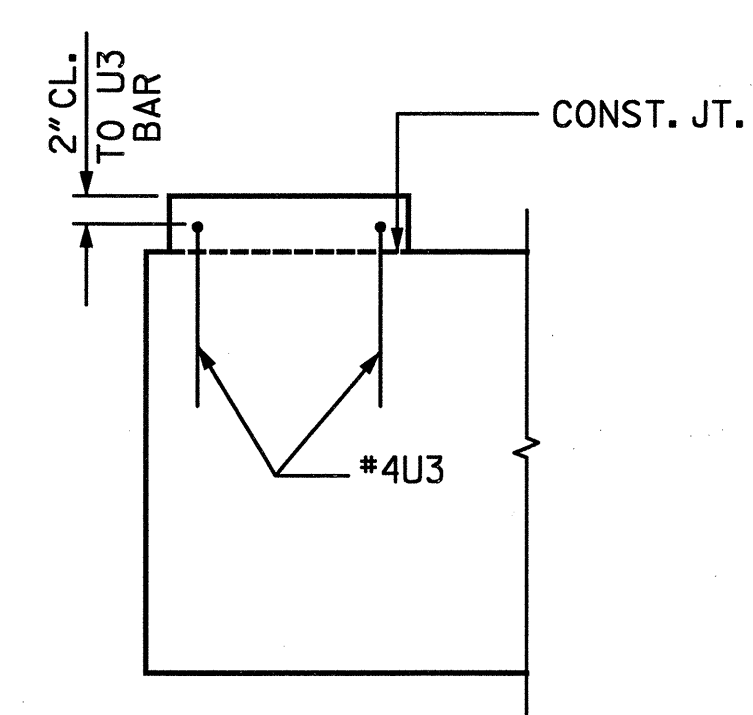

ELEVATION

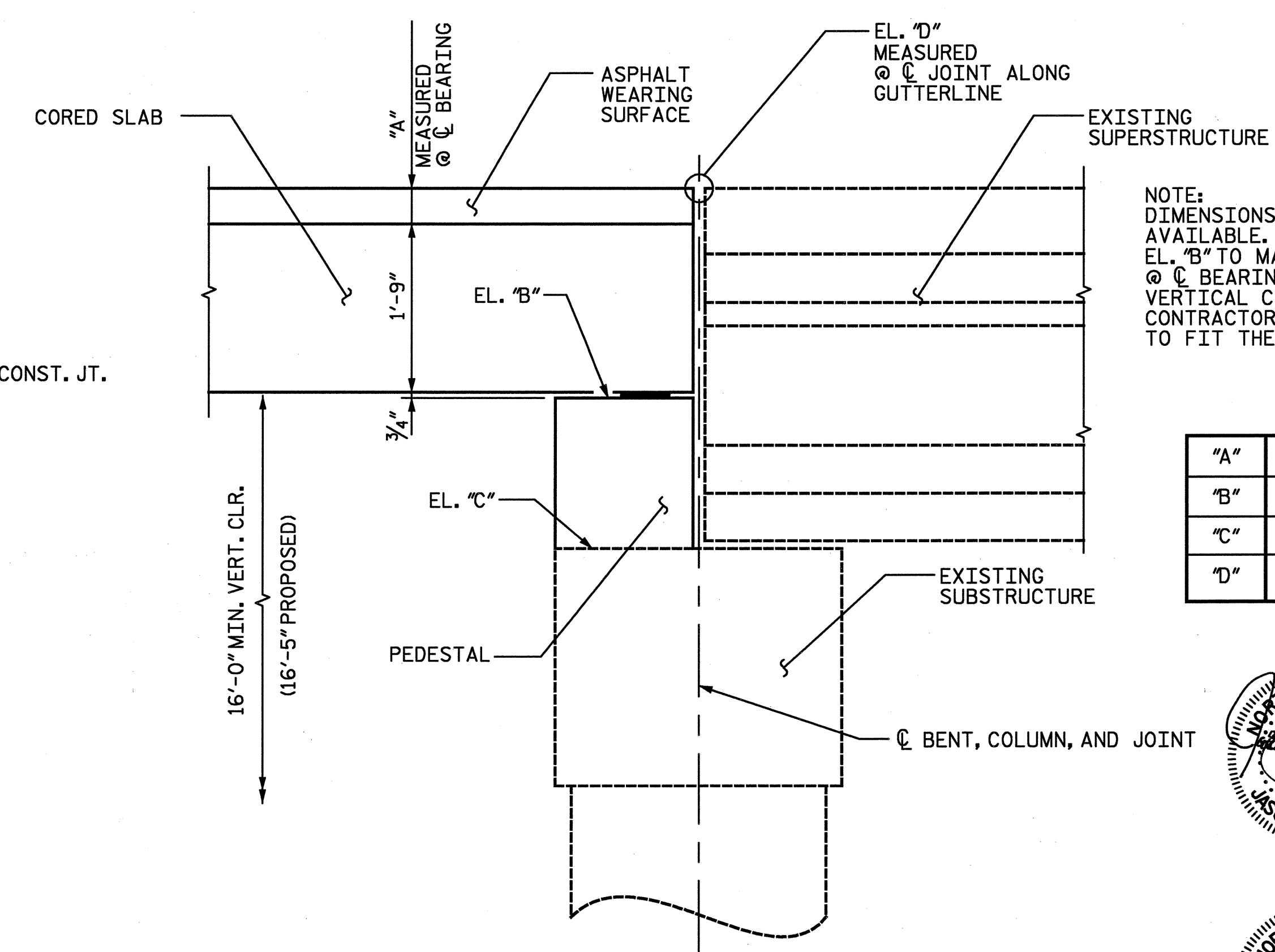

PEDESTAL HEIGHT

"A"	3 1/2"
"B"	186.74
"C"	184.95
"D"	188.84

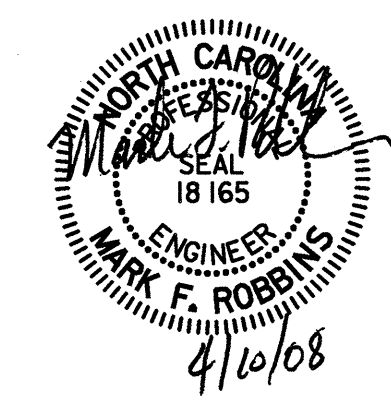
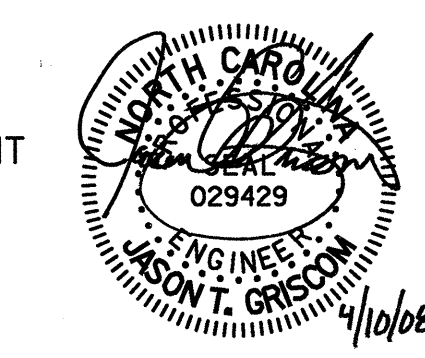

PROJECT NO. **B-5021**
 ROBESON COUNTY
 BRIDGE: **169**
 SHEET 2 OF 2

STATE OF NORTH CAROLINA
 DEPARTMENT OF TRANSPORTATION
 RALEIGH
**SUBSTRUCTURE
 BENT 3**

REVISIONS				SHEET NO.
NO.	BY:	DATE:	NO.	DATE:
1			3	
2			4	

TOTAL SHEETS: 62

DRAWN BY: **TRL** DATE: **1-08**
 CHECKED BY: **PEK** DATE: **2-08**

D-1809.62
STV / Ralph Whitehead Associates, Inc.
 1000 West Morehead St., Ste. 200
 Charlotte, NC 28208

STANDARD NOTES

DESIGN DATA:

SPECIFICATIONS	-----	A.A.S.H.T.O. (CURRENT)
LIVE LOAD	-----	SEE PLANS
IMPACT ALLOWANCE	-----	SEE A.A.S.H.T.O.
STRESS IN EXTREME FIBER OF		
STRUCTURAL STEEL - AASHTO M270 GRADE 36	-	20,000 LBS. PER SQ. IN.
- AASHTO M270 GRADE 50W	-	27,000 LBS. PER SQ. IN.
- AASHTO M270 GRADE 50	-	27,000 LBS. PER SQ. IN.
REINFORCING STEEL IN TENSION		
GRADE 60	--	24,000 LBS. PER SQ. IN.
CONCRETE IN COMPRESSION	-----	1,200 LBS. PER SQ. IN.
CONCRETE IN SHEAR	-----	SEE A.A.S.H.T.O.
STRUCTURAL TIMBER - TREATED OR		
UNTREATED - EXTREME FIBER STRESS	-----	1,800 LBS. PER SQ. IN.
COMPRESSION PERPENDICULAR TO GRAIN OF TIMBER	-----	375 LBS. PER SQ. IN.
EQUIVALENT FLUID PRESSURE OF EARTH	-----	30 LBS. PER CU. FT. (MINIMUM)

MATERIAL AND WORKMANSHIP:

EXCEPT AS MAY OTHERWISE BE SPECIFIED ON PLANS OR IN THE SPECIAL PROVISIONS, ALL MATERIAL AND WORKMANSHIP SHALL BE IN ACCORDANCE WITH THE 2002 STANDARD SPECIFICATIONS "FOR ROADS AND STRUCTURES" OF THE N. C. DEPARTMENT OF TRANSPORTATION.

STEEL SHEET PILING FOR PERMANENT OR TEMPORARY APPLICATIONS SHALL BE HOT ROLLED.

CONCRETE:

UNLESS OTHERWISE REQUIRED ON PLANS, CLASS A CONCRETE SHALL BE USED FOR ALL PORTIONS OF ALL STRUCTURES WITH THE EXCEPTION THAT: CLASS AA CONCRETE SHALL BE USED IN BRIDGE SUPERSTRUCTURES, ABUTMENT BACKWALLS, AND APPROACH SLABS; CLASS B CONCRETE SHALL BE USED FOR SLOPE PROTECTION AND RIP RAP; AND CLASS S SHALL BE USED FOR UNDERWATER FOOTING SEALS.

CONCRETE CHAMFERS:

UNLESS OTHERWISE NOTED ON THE PLANS, ALL EXPOSED CORNERS ON STRUCTURES SHALL BE CHAMFERED 3/4" WITH THE FOLLOWING EXCEPTIONS: TOP CORNERS OF CURBS MAY BE ROUNDED TO 1-1/2" RADIUS WHICH IS BUILT INTO CURB FORMS; CORNERS OF TRANSVERSE FLOOR EXPANSION JOINTS SHALL BE ROUNDED WITH A 1/4" FINISHING TOOL UNLESS OTHERWISE REQUIRED ON PLANS; AND CORNERS OF EXPANSION JOINTS IN THE ROADWAY FACES AND TOPS OF CURBS AND SIDEWALKS SHALL BE ROUNDED TO A 1/4" RADIUS WITH A FINISHING STONE OR TOOL UNLESS OTHERWISE REQUIRED ON PLANS.

DOWELS:

DOWELS WHEN INDICATED ON PLANS AS FOR CULVERT EXTENSIONS, SHALL BE EMBEDDED AT LEAST 12" INTO THE OLD CONCRETE AND GROUTED INTO PLACE WITH 1:2 CEMENT MORTAR.

ALLOWANCE FOR DEAD LOAD DEFLECTION, SETTLEMENT, ETC. IN CASTING SUPERSTRUCTURES:

BRIDGES SHALL BE BUILT ON THE GRADE OR VERTICAL CURVE SHOWN ON PLANS. SLABS, CURBS AND PARAPETS SHALL CONFORM TO THE GRADE OR CURVE.

ALL DIMENSIONS WHICH ARE GIVEN IN SECTION AND ARE AFFECTED BY DEAD LOAD DEFLECTIONS ARE DIMENSIONS AT CENTER LINE OF BEARING UNLESS OTHERWISE NOTED ON PLANS. IN SETTING FORMS FOR STEEL BEAM BRIDGES AND PRESTRESSED CONCRETE GIRDER BRIDGES, ADJUSTMENTS SHALL BE MADE DUE TO THE DEAD LOAD DEFLECTIONS FOR THE ELEVATIONS SHOWN. WHERE BLOCKS ARE SHOWN OVER BEAMS FOR BUILDING UP TO THE SLAB, THE VERTICAL DIMENSIONS OF THE BLOCKS SHALL BE ADJUSTED BETWEEN BEARINGS TO COMPENSATE FOR DEAD LOAD DEFLECTIONS, VERTICAL CURVE ORDINATE, AND ACTUAL BEAM CAMBER. WHERE BOTTOM OF SLAB IS IN LINE WITH BOTTOM OF TOP FLANGES, DEPTH OF SLAB BETWEEN BEARINGS SHALL BE ADJUSTED TO COMPENSATE FOR DEAD LOAD DEFLECTION, VERTICAL CURVE ORDINATE, AND ACTUAL BEAM CAMBER.

IN SETTING FALSEWORK AND FORMS FOR REINFORCED CONCRETE SPANS, AN ALLOWANCE SHALL BE MADE FOR DEAD LOAD DEFLECTIONS, SETTLEMENT OF FALSEWORK, AND PERMANENT CAMBER WHICH SHALL BE PROVIDED FOR IN ADDITION TO THE ELEVATIONS SHOWN. AFTER REMOVAL OF THE FALSEWORK, THE FINISHED STRUCTURES SHALL CONFORM TO THE PROFILE AND ELEVATIONS SHOWN ON THE PLANS AND CONSTRUCTION ELEVATIONS FURNISHED BY THE ENGINEER.

DETAILED DRAWINGS FOR FALSEWORK OR FORMS FOR BRIDGE SUPERSTRUCTURE AND ANY STRUCTURE OR PARTS OF A STRUCTURE AS NOTED ON THE PLANS SHALL BE SUBMITTED TO THE ENGINEER FOR APPROVAL BEFORE CONSTRUCTION OF THE FALSEWORK OR FORMS IS STARTED.

REINFORCING STEEL:

ALL REINFORCING STEEL SHALL BE DEFORMED WITH THE EXCEPTION OF #2 BARS WHICH MAY BE FABRICATED FROM COLD DRAWN STEEL WIRE. DIMENSIONS RELATIVE TO PLACEMENT OF REINFORCING ARE TO CENTERS OF BARS UNLESS OTHERWISE INDICATED IN THE PLANS. DIMENSIONS ON BAR DETAILS ARE TO CENTERS OF BARS OR ARE OUT TO OUT AS INDICATED ON PLANS.

WIRE BAR SUPPORTS SHALL BE PROVIDED FOR REINFORCING STEEL WHERE INDICATED ON THE PLANS. WHEN BAR SUPPORT PIECES ARE PLACED IN CONTINUOUS LINES, THEY SHALL BE SO PLACED THAT THE ENDS OF THE SUPPORTING WIRES SHALL BE LAPPED TO LOCK LEGS ON ADJOINING PIECES.

STRUCTURAL STEEL:

AT THE CONTRACTOR'S OPTION, HE MAY SUBSTITUTE 7/8" Ø SHEAR STUDS FOR THE 3/4" Ø STUDS SPECIFIED ON THE PLANS. THIS SUBSTITUTION SHALL BE MADE AT THE RATE OF 3 - 7/8" Ø STUDS FOR 4 - 3/4" Ø STUDS, AND STUD SPACING CHANGES SHALL BE MADE AS NECESSARY TO PROVIDE THE SAME EQUIVALENT NUMBER OF 7/8" Ø STUDS ALONG THE BEAM AS SHOWN FOR 3/4" Ø STUDS BASED ON THE RATIO OF 3 - 7/8" Ø STUDS FOR 4 - 3/4" Ø STUDS. STUDS OF THE LENGTH SPECIFIED ON THE PLANS MUST BE PROVIDED. THE MAXIMUM SPACING SHALL BE 2'-0".

EXCEPT AT THE INTERIOR SUPPORTS OF CONTINUOUS BEAMS WHERE THE COVER PLATE IS IN CONTACT WITH BEARING PLATE, THE CONTRACTOR MAY, AT HIS OPTION, SUBSTITUTE FOR THE COVER PLATES DESIGNATED ON THE PLANS COVER PLATES OF THE EQUIVALENT AREA PROVIDED THESE PLATES ARE AT LEAST 5/16" IN THICKNESS AND DO NOT EXCEED A WIDTH EQUAL TO THE FLANGE WIDTH LESS 2" OR A THICKNESS EQUAL TO 2 TIMES THE FLANGE THICKNESS. THE SIZE OF FILLET WELDS SHALL CONFORM TO THE REQUIREMENTS OF THE CURRENT ANSI/AASHTO/AWS "BRIDGE WELDING CODE". ELECTROSLAG WELDING WILL NOT BE PERMITTED.

PLACEMENT OF BEAM OR GIRDER MEMBERS ON TRUCKS FOR HAULING SHALL BE DONE IN COMPLIANCE WITH LIMITS SHOWN ON SKETCHES PROVIDED TO THE MATERIALS AND TEST UNIT APPROVED BY THE STRUCTURE DESIGN UNIT DATED MAY 8, 1991. THESE SKETCHES PRIMARILY LIMIT THE UNSUPPORTED CANTILEVER LENGTH OF MEMBERS. WHEN THE CONTRACTOR WISHES TO PLACE MEMBERS ON TRUCKS NOT IN ACCORDANCE WITH THESE LIMITS, TO SHIP BY RAIL, TO ATTACH SHIPPING RESTRAINTS TO THE MEMBERS OR TO INVERT MEMBERS, HE SHALL SUBMIT A SKETCH FOR APPROVAL PRIOR TO SHIPPING. SEE ALSO ARTICLE 1072-11.

WITH THE SOLE EXCEPTION OF EDGES AT SURFACES WHICH BEAR ON OTHER SURFACES, ALL SHARP EDGES AND ENDS OF SHAPES AND PLATES SHALL BE SLIGHTLY ROUNDED BY SUITABLE MEANS TO A RADIUS OF APPROXIMATELY 1/16 INCH OR EQUIVALENT FLAT SURFACE AT A SUITABLE ANGLE PRIOR TO PAINTING, GALVANIZING, OR METALLIZING.

HANDRAILS AND POSTS:

METAL STANDARDS AND FACES OF THE CONCRETE END POSTS FOR THE METAL RAIL SHALL BE SET NORMAL TO THE GRADE OF THE CURB, UNLESS OTHERWISE SHOWN ON PLANS. THE METAL RAIL AND TOPS OF CONCRETE POSTS USED WITH THE ALUMINUM RAIL SHALL BE BUILT PARALLEL TO THE GRADE OF THE CURB.

METAL HANDRAILS SHALL BE IN ACCORDANCE WITH THE PLANS. RAILS SHALL BE AS MANUFACTURED FOR BRIDGE RAILING. CASTINGS SHALL BE OF A UNIFORM APPEARANCE. FINIS AND OTHER DEFORMATIONS RESULTING FROM CASTING OR OTHERWISE SHALL BE REMOVED IN A MANNER SO THAT A UNIFORM COLORING OF THE COMPLETED CASTING SHALL BE OBTAINED. CASTINGS WITH DISCOLORATIONS OR OF NON-UNIFORM COLORING WILL NOT BE ACCEPTED. CERTIFIED MILL REPORTS ARE REQUIRED FOR METAL RAILS AND POSTS.

SPECIAL NOTES:

GENERALLY, IN CASE OF DISCREPANCY, THIS STANDARD SHEET OF NOTES SHALL GOVERN OVER THE SPECIFICATIONS, BUT THE REMAINDER OF THE PLANS SHALL GOVERN OVER NOTES HEREON, AND SPECIAL PROVISIONS SHALL GOVERN OVER ALL. SEE SPECIFICATIONS ARTICLE 105-4.

ENGLISH

JANUARY, 1990

STD. NO. SN