

**TEMP. PAV'T MARKING SCHEDULE**

SYMBOL	DESCRIPTION	BREAKDOWN	PAY ITEM
		PAVEMENT MARKING LINES	
			PAINT (4")
PA	WHITE EDGELINE		
PC	10ft WHITE SKIP		
PD	2ft WHITE MINISKIP		
PE	WHITE SOLID LANE LINE		
PF	10ft YELLOW SKIP		
PH	YELLOW SINGLE CENTER LINE		
PI	YELLOW DOUBLE CENTER LINE		
			PAINT (8")
PV	YELLOW DIAGONAL		
			PAINT (24")
P4	WHITE STOPBAR		
		COLD APPLIED PLASTIC TYPE IV (TAPE) (4')	
RA	WHITE EDGELINE		
RI	YELLOW DOUBLE CENTER LINE		
		PAVEMENT MARKING SYMBOLS	
			PAINT SYMBOL
QA	LEFT TURN ARROW		
QB	RIGHT TURN ARROW		
QC	STRAIGHT ARROW		
QE	COMBO STRAIGHT / RIGHT TURN ARROW		
QG	COMBO LEFT / RIGHT / STRAIGHT ARROW		
			PAINT CHARACTER
QI	ALPHANUMERIC CHARACTER		
		PAVEMENT MARKERS	
			TEMPORARY RAISED
MH	YELLOW AND YELLOW		
MI	CRYSTAL AND RED		

**FINAL PAV'T MARKING SCHEDULE**

SYMBOL	DESCRIPTION	BREAKDOWN	PAY ITEM
		PAVEMENT MARKING LINES	
			POLYUREA (4", 20mls)
VA	WHITE EDGELINE		
VC	10ft WHITE SKIP		
VD	2ft WHITE MINISKIP		
VE	WHITE SOLID LANE LINE		
VF	10ft YELLOW SKIP		
VH	YELLOW SINGLE CENTER LINE		
VI	YELLOW DOUBLE CENTER LINE		
			POLYUREA (8", 20mls)
VQ	WHITE DIAGONAL		
VT	YELLOW DIAGONAL		
			POLYUREA (24", 20mls)
V2	WHITE STOPBAR		
		PAVEMENT MARKING SYMBOLS	
			POLYUREA SYMBOL
WA	LEFT TURN ARROW		
WB	RIGHT TURN ARROW		
WC	STRAIGHT ARROW		
WE	COMBO STRAIGHT / RIGHT TURN ARROW		
WG	COMBO LEFT / RIGHT / STRAIGHT ARROW		
			POLYUREA CHARACTER
WI	ALPHANUMERIC CHARACTER		
		PAVEMENT MARKERS	
			PERMANENT RAISED
MA	YELLOW AND YELLOW		
MB	CRYSTAL AND RED		

12/14/2007  
 P:\TIP\2320g\ko\2320g\TrafficControl\CP\002\2320G\_TC.pmp\dgn  
 Ko & Associates, P.C.

APPROVED: <i>Michael T. Rzepka</i> DATE: 1-3-08	<b>TEMP./FINAL PAVEMENT MARKING SCHEDULES</b>	
SEAL		
	SCALE: NONE	
	DATE: 12-07	
	DWG. BY: BLM	
	DESIGN BY: BLM	
REVIEWED BY: MTR	REVISIONS	

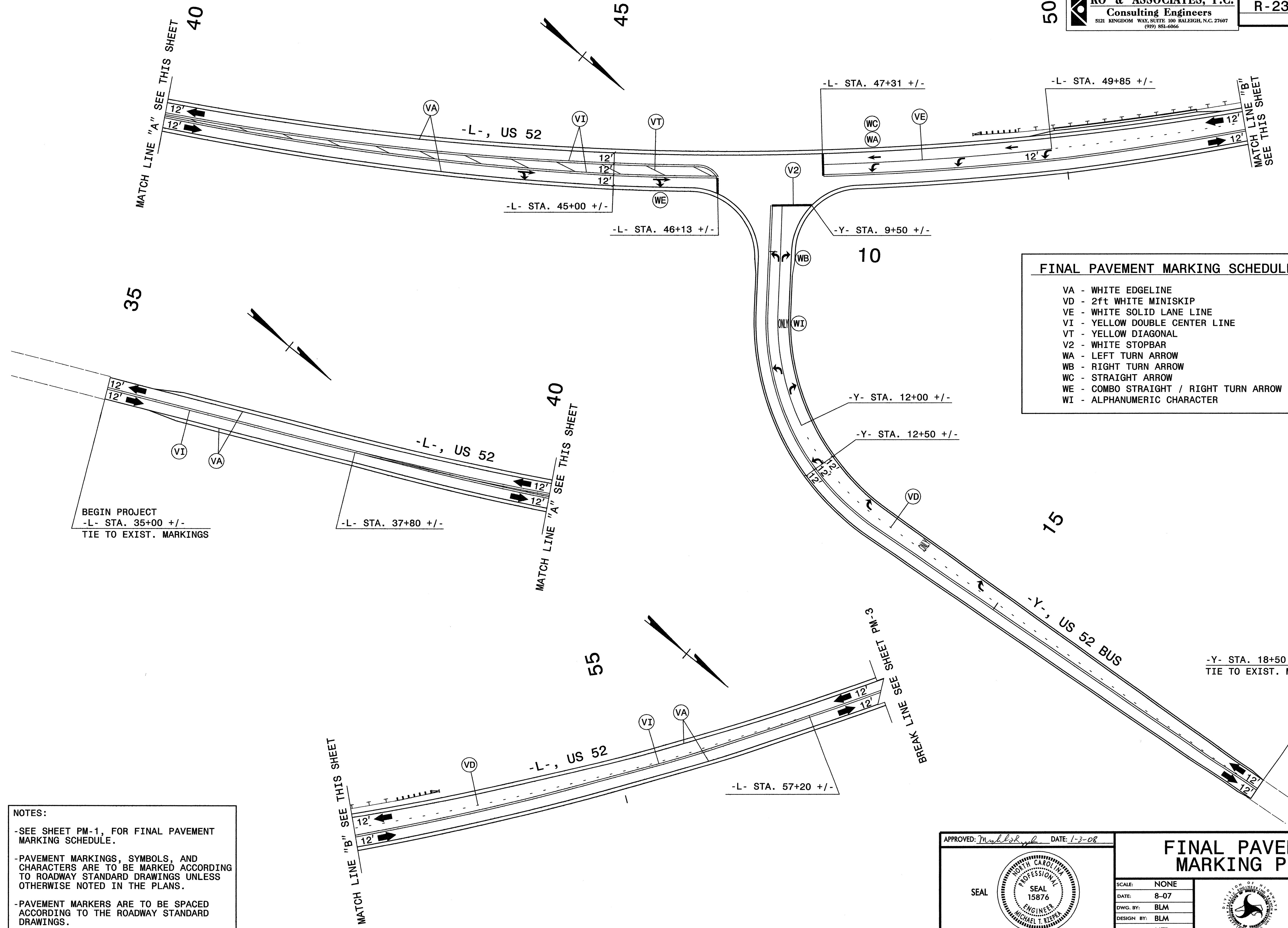

**FINAL PAVEMENT MARKING SCHEDULE**

- VA - WHITE EDGELINE
- VD - 2ft WHITE MINISKIP
- VE - WHITE SOLID LANE LINE
- VI - YELLOW DOUBLE CENTER LINE
- VT - YELLOW DIAGONAL
- V2 - WHITE STOPBAR
- WA - LEFT TURN ARROW
- WB - RIGHT TURN ARROW
- WC - STRAIGHT ARROW
- WE - COMBO STRAIGHT / RIGHT TURN ARROW
- WI - ALPHANUMERIC CHARACTER

**NOTES:**

- SEE SHEET PM-1, FOR FINAL PAVEMENT MARKING SCHEDULE.
- PAVEMENT MARKINGS, SYMBOLS, AND CHARACTERS ARE TO BE MARKED ACCORDING TO ROADWAY STANDARD DRAWINGS UNLESS OTHERWISE NOTED IN THE PLANS.
- PAVEMENT MARKERS ARE TO BE SPACED ACCORDING TO THE ROADWAY STANDARD DRAWINGS.

APPROVED: *Michael T. Rierma* DATE: 1-3-08

SEAL

**FINAL PAVEMENT MARKING PLAN**

SCALE:	NONE
DATE:	8-07
DWG. BY:	BLM
DESIGN BY:	BLM
REVIEWED BY:	MTR

REVISIONS	

CADD FILE

12/20/2007  
 P:\TIP\2320g.ko\2320g\TrafficControl\TCP\000\AR2320G\_TC\_pmp2.dgn  
 KO & Associates, P.C.

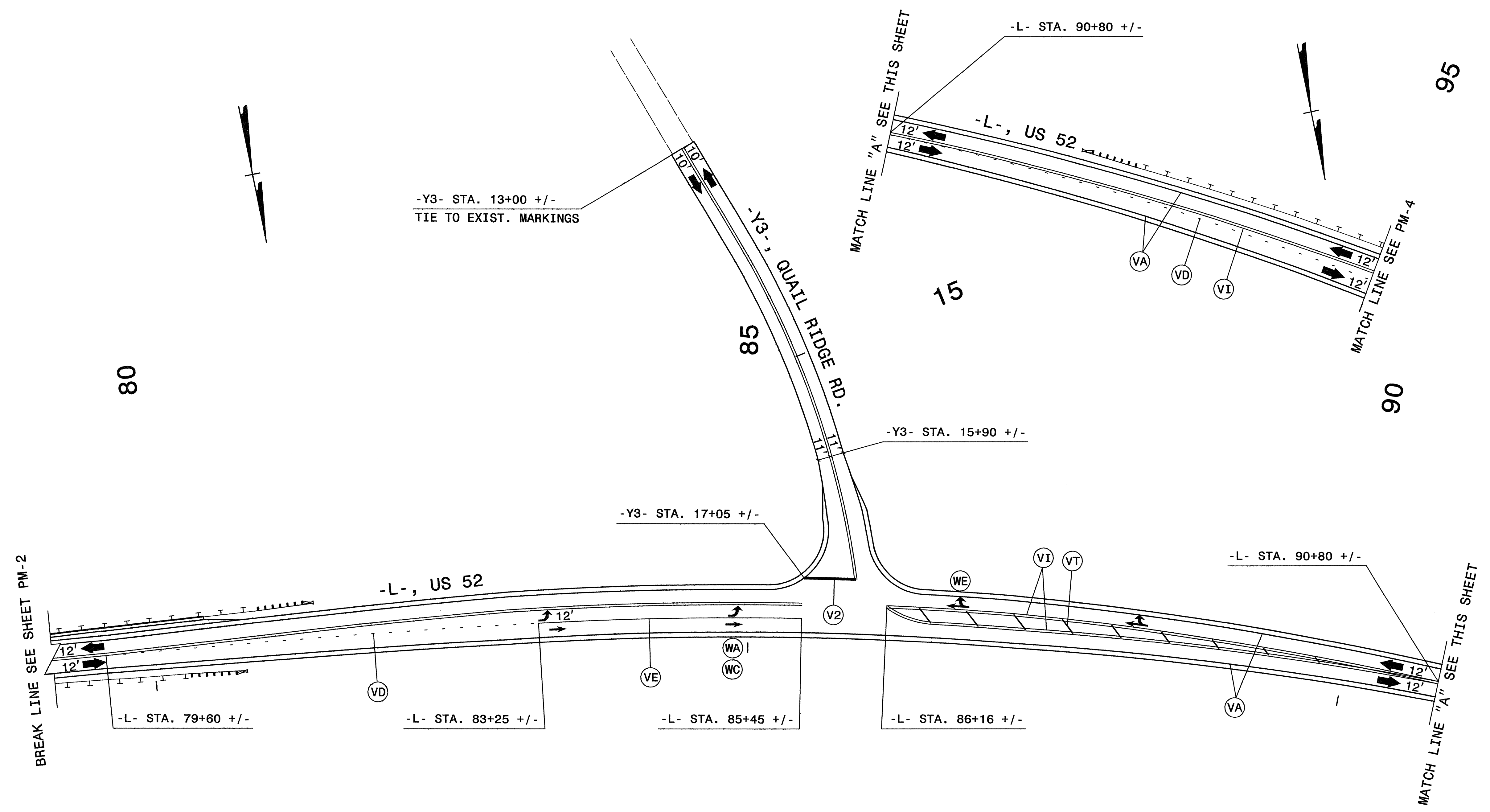

**FINAL PAVEMENT MARKING SCHEDULE**

- VA - WHITE EDGELINE
- VD - 2ft WHITE MINISKIP
- VE - WHITE SOLID LANE LINE
- VI - YELLOW DOUBLE CENTER LINE
- VT - YELLOW DIAGONAL
- V2 - WHITE STOPBAR
- WA - LEFT TURN ARROW
- WC - STRAIGHT ARROW
- WE - COMBO STRAIGHT / RIGHT TURN ARROW
- WF - COMBO LEFT / RIGHT TURN ARROW

**NOTES:**

- SEE SHEET PM-1, FOR FINAL PAVEMENT MARKING SCHEDULE.
- PAVEMENT MARKINGS, SYMBOLS, AND CHARACTERS ARE TO BE MARKED ACCORDING TO ROADWAY STANDARD DRAWINGS UNLESS OTHERWISE NOTED IN THE PLANS.
- PAVEMENT MARKERS ARE TO BE SPACED ACCORDING TO THE ROADWAY STANDARD DRAWINGS.

APPROVED: *Michael T. Kierma* DATE: 1-3-08

**FINAL PAVEMENT MARKING PLAN**

SCALE: NONE		REVISIONS
DATE: 12-07		
DWG. BY: BLM		
DESIGN BY: BLM		
REVIEWED BY: MTR		

**NOTES:**

- SEE SHEET PM-1, FOR FINAL PAVEMENT MARKING SCHEDULE.
- PAVEMENT MARKINGS, SYMBOLS, AND CHARACTERS ARE TO BE MARKED ACCORDING TO ROADWAY STANDARD DRAWINGS UNLESS OTHERWISE NOTED IN THE PLANS.
- PAVEMENT MARKERS ARE TO BE SPACED ACCORDING TO THE ROADWAY STANDARD DRAWINGS.

- FINAL PAVEMENT MARKING SCHEDULE**
- VA - WHITE EDGELINE
  - VD - 2ft WHITE MINISKIP
  - VE - WHITE SOLID LANE LINE
  - VI - YELLOW DOUBLE CENTER LINE
  - V2 - WHITE STOPBAR
  - WA - LEFT TURN ARROW
  - WE - COMBO STRAIGHT / RIGHT TURN ARROW
  - WF - COMBO LEFT / RIGHT TURN ARROW
  - WG - COMBO LEFT / RIGHT / STRAIGHT ARROW

95

100

10

105

15

15

110

25

MATCH LINE SEE PM-3

MATCH LINE "B" SEE THIS SHEET

MATCH LINE "B" SEE THIS SHEET

BREAK LINE SEE PM-5

BREAK LINE "A" SEE THIS SHEET

-Y4- STA. 4+61 +/-  
 TIE TO EXIST. MARKINGS  
 -Y4- STA. 5+25 +/-  
 -Y4-, SOUTHSIDE RD.  
 BREAK LINE "A" SEE THIS SHEET

TIE TO EXIST. MARKINGS  
 TIE TO EXIST. MARKINGS  
 -Y4- STA. 25+20 +/-  
 -Y4- STA. 25+75 +/-  
 -Y4- STA. 26+50 +/-  
 TIE TO EXIST. MARKINGS

BREAK LINE "C" SEE THIS SHEET  
 -Y4- STA. 13+03 +/-  
 -L-, US 52  
 -L- STA. 98+00 +/-  
 -L- STA. 98+30 +/-  
 -L- STA. 100+80 +/-  
 -Y4- STA. 15+21 +/-  
 -Y4- STA. 15+80 +/-

-L- STA. 101+70 +/-  
 -L- STA. 104+20 +/-  
 -L- STA. 105+00 +/-  
 -Y4- STA. 13+59 +/-

SR 2 STA. 10+22 +/-  
 SR 2 STA. 11+13 +/-  
 SR 2  
 SR 2 STA. 17+55 +/-

-L- STA. 112+20 +/-  
 -L-, US 52

APPROVED: *Michael T. Kieper* DATE: 1-3-08

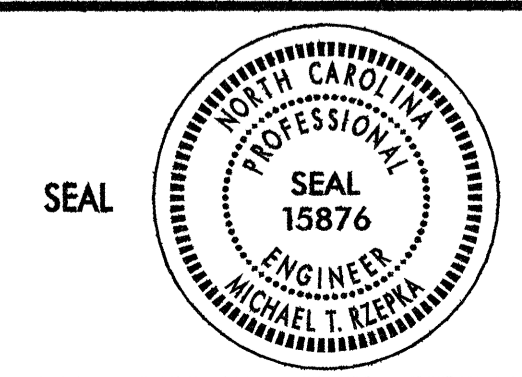

**FINAL PAVEMENT MARKING PLAN**

SCALE: NONE		REVISIONS
DATE: 12-07		
DWG. BY: BLM		
DESIGN BY: BLM		
REVIEWED BY: MTR		CARD FILE

12/14/2007  
 P:\TIP\2320g\_ko\2320g\TrafficControl\CP\002\2320G\_TC\_pmp4.dgn  
 KO & Associates, P.C.

**NOTES:**



- SEE SHEET PM-1, FOR FINAL PAVEMENT MARKING SCHEDULE.
- PAVEMENT MARKINGS, SYMBOLS, AND CHARACTERS ARE TO BE MARKED ACCORDING TO ROADWAY STANDARD DRAWINGS UNLESS OTHERWISE NOTED IN THE PLANS.
- PAVEMENT MARKERS ARE TO BE SPACED ACCORDING TO THE ROADWAY STANDARD DRAWINGS.

**FINAL PAVEMENT MARKING SCHEDULE**

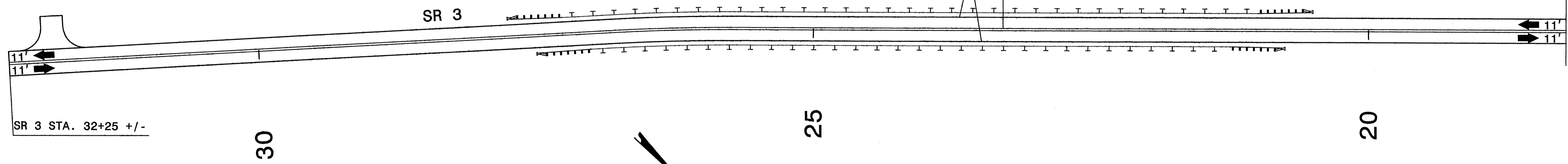
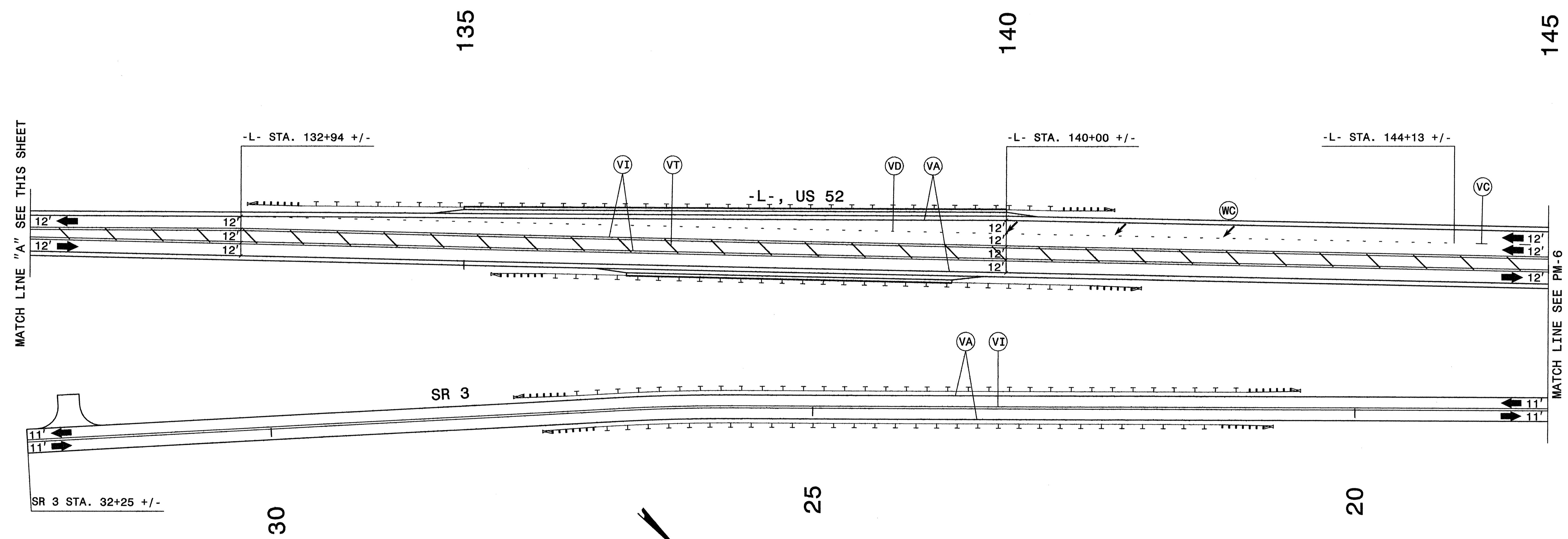
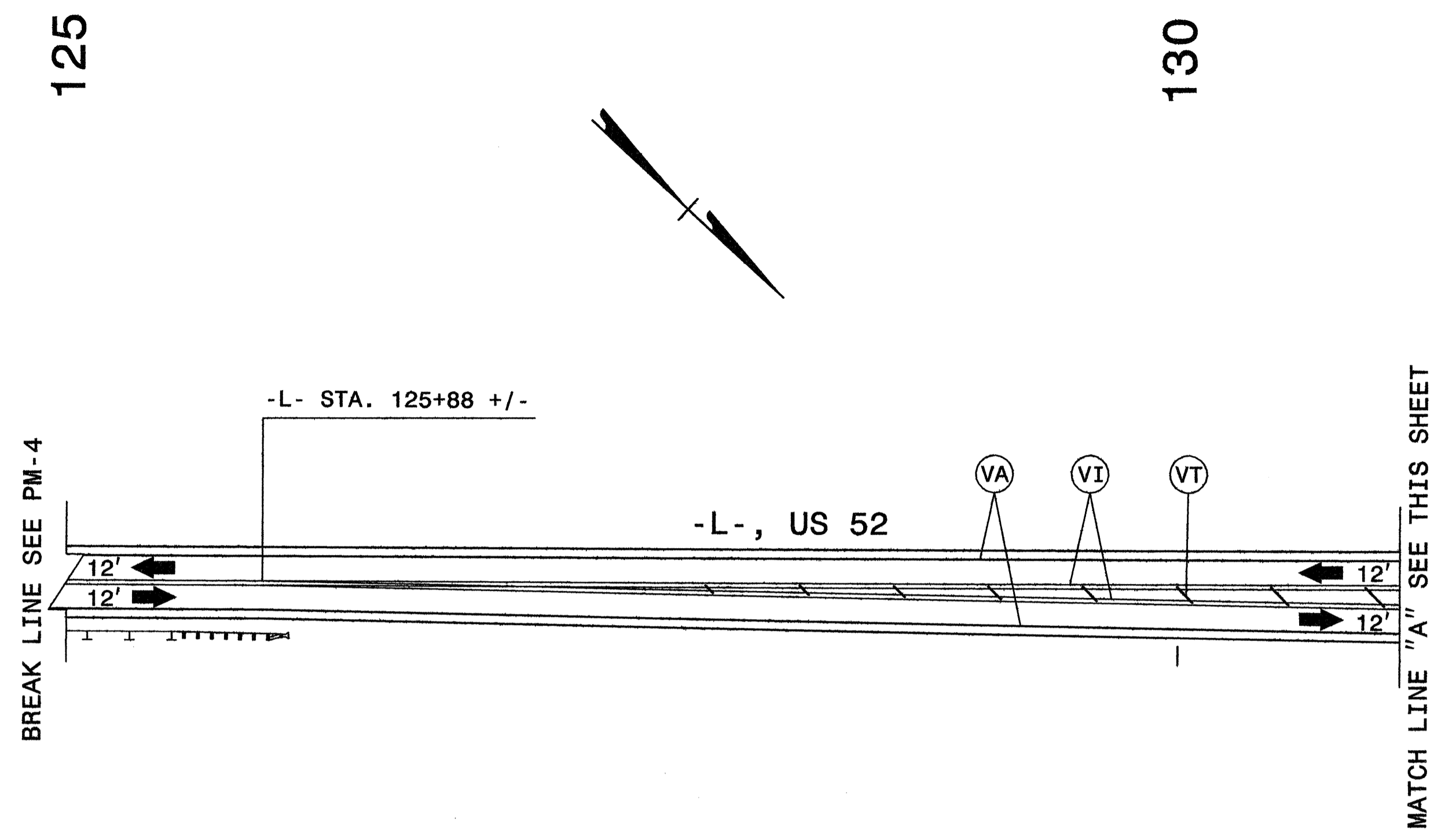
- VA - WHITE EDGELINE
- VC - 10ft WHITE SKIP
- VD - 2ft WHITE MINISKIP
- VI - YELLOW DOUBLE CENTER LINE
- VT - YELLOW DIAGONAL
- WC - STRAIGHT ARROW

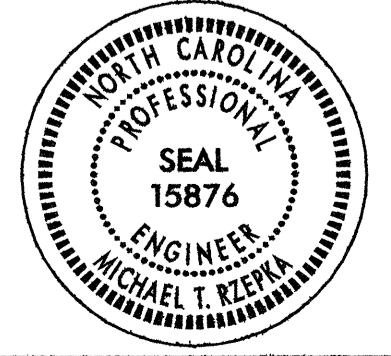

12/14/2007  
 P:\TIP\2320g\ko\2320g\TrafficControl\CP\002\AR2320G\_TC.pmp5.dgn  
 KO & Associates, P.C.

APPROVED: <i>Michael T. Riepl</i> DATE: 1-3-08 SEAL 	<b>FINAL PAVEMENT MARKING PLAN</b>							
	SCALE: NONE DATE: 12-07 DWG. BY: BLM DESIGN BY: BLM REVIEWED BY: MTR		REVISIONS <table border="1"> <tr><td> </td><td> </td></tr> <tr><td> </td><td> </td></tr> <tr><td> </td><td> </td></tr> </table>					

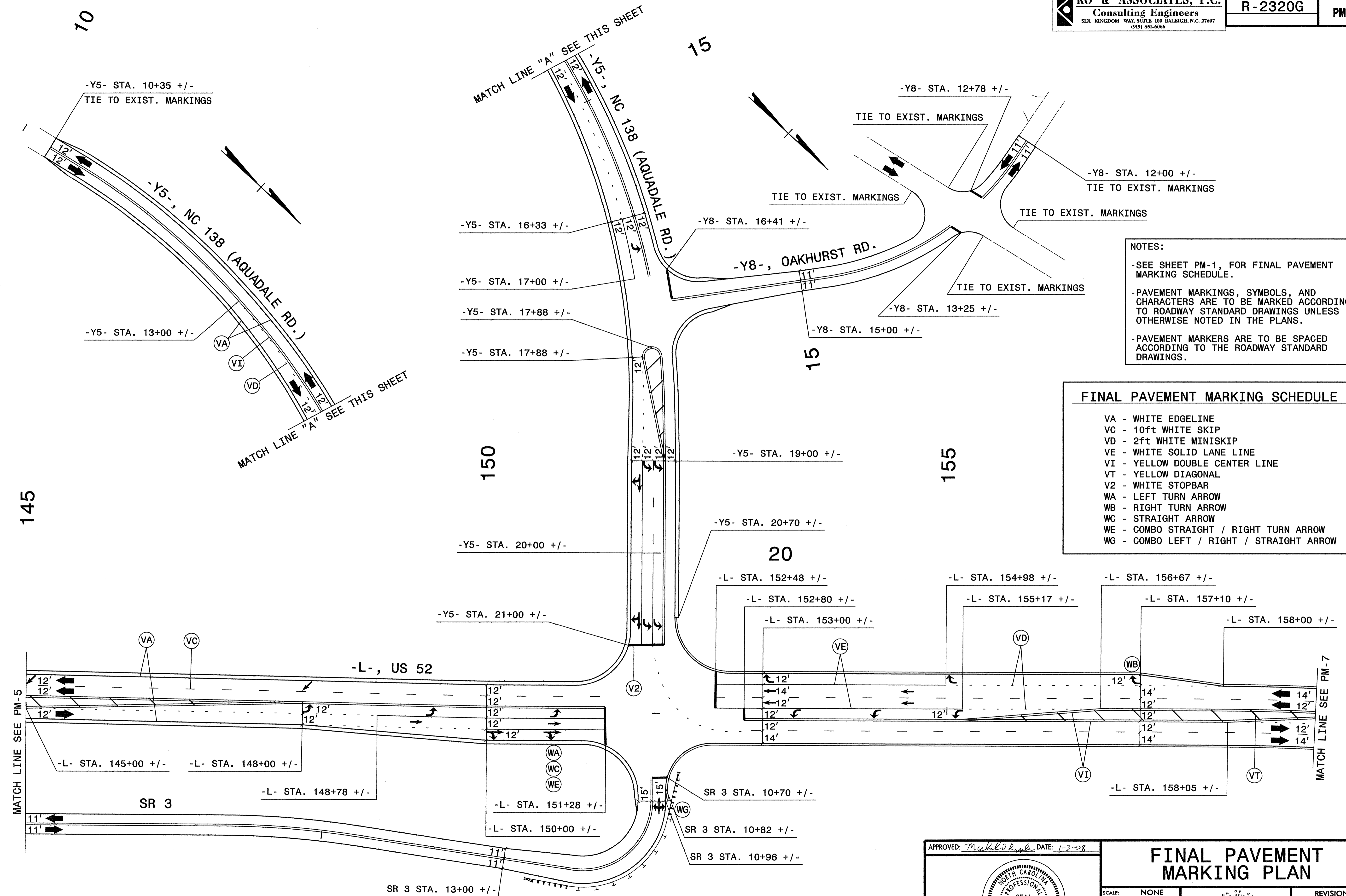

**NOTES:**

- SEE SHEET PM-1, FOR FINAL PAVEMENT MARKING SCHEDULE.
- PAVEMENT MARKINGS, SYMBOLS, AND CHARACTERS ARE TO BE MARKED ACCORDING TO ROADWAY STANDARD DRAWINGS UNLESS OTHERWISE NOTED IN THE PLANS.
- PAVEMENT MARKERS ARE TO BE SPACED ACCORDING TO THE ROADWAY STANDARD DRAWINGS.

**FINAL PAVEMENT MARKING SCHEDULE**

- VA - WHITE EDGELINE
- VC - 10ft WHITE SKIP
- VD - 2ft WHITE MINISKIP
- VE - WHITE SOLID LANE LINE
- VI - YELLOW DOUBLE CENTER LINE
- VT - YELLOW DIAGONAL
- V2 - WHITE STOPBAR
- WA - LEFT TURN ARROW
- WB - RIGHT TURN ARROW
- WC - STRAIGHT ARROW
- WE - COMBO STRAIGHT / RIGHT TURN ARROW
- WG - COMBO LEFT / RIGHT / STRAIGHT ARROW

APPROVED: *Michael T. Kemp* DATE: 1-3-08

SEAL

**FINAL PAVEMENT MARKING PLAN**

SCALE: NONE		<table border="1"> <tr><th colspan="2">REVISIONS</th></tr> <tr><td> </td><td> </td></tr> <tr><td> </td><td> </td></tr> <tr><td> </td><td> </td></tr> </table>	REVISIONS							
REVISIONS										
DATE: 8-07										
DWG. BY: BLM										
DESIGN BY: BLM										
REVIEWED BY: MTR	CARD FILE									

12/27/2007  
 R:\TrafficControl\TC\PM\002\AR2320G\_TC.pmp6.dgn  
 KO & Associates, P.C.

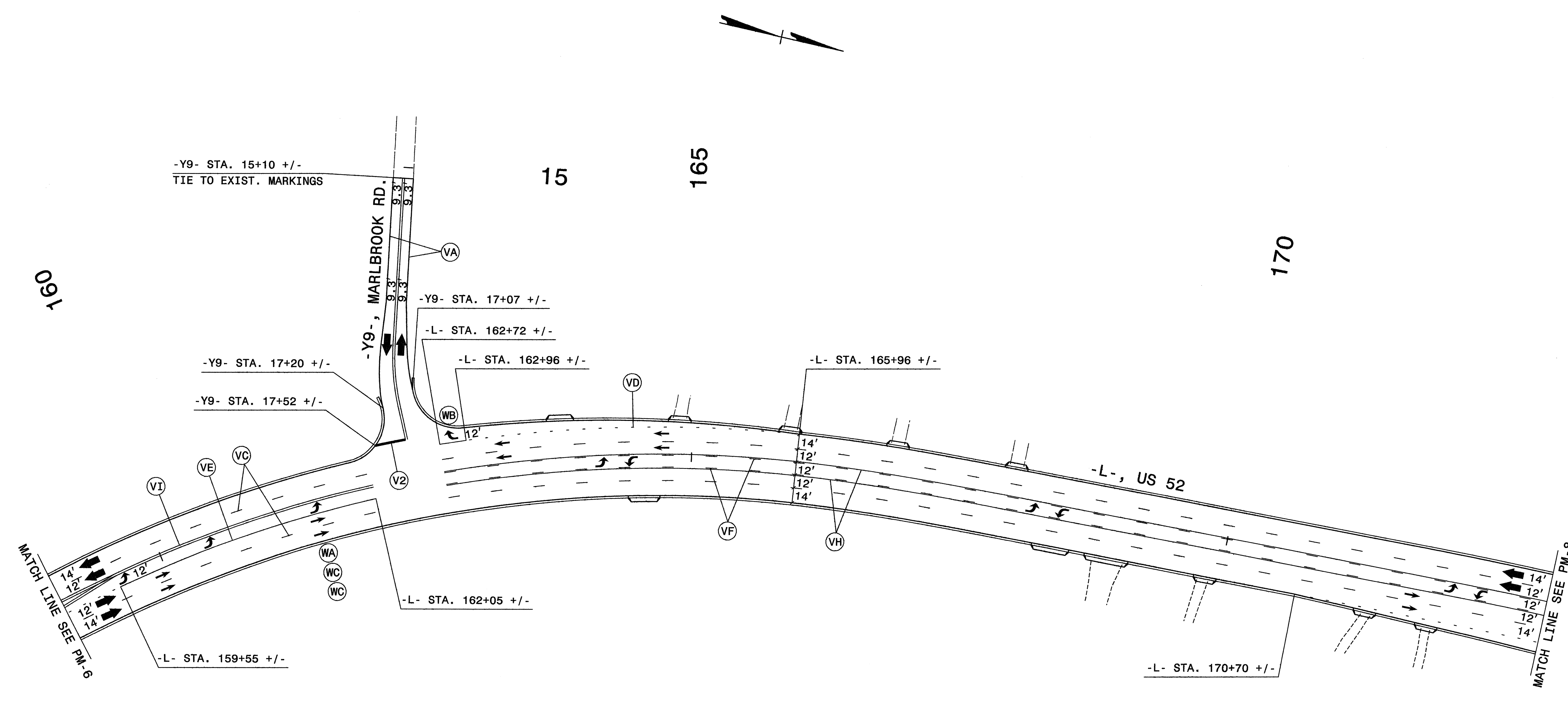

**FINAL PAVEMENT MARKING SCHEDULE**

VA	- WHITE EDGELINE
VC	- 10ft WHITE SKIP
VD	- 2ft WHITE MINISKIP
VE	- WHITE SOLID LANE LINE
VF	- 10ft YELLOW SKIP
VH	- YELLOW SINGLE CENTER LINE
VI	- YELLOW DOUBLE CENTER LINE
V2	- WHITE STOPBAR
WA	- LEFT TURN ARROW
WB	- RIGHT TURN ARROW
WC	- STRAIGHT ARROW
WF	- COMBO LEFT / RIGHT TURN ARROW

**NOTES:**

- SEE SHEET PM-1, FOR FINAL PAVEMENT MARKING SCHEDULE.
- PAVEMENT MARKINGS, SYMBOLS, AND CHARACTERS ARE TO BE MARKED ACCORDING TO ROADWAY STANDARD DRAWINGS UNLESS OTHERWISE NOTED IN THE PLANS.
- PAVEMENT MARKERS ARE TO BE SPACED ACCORDING TO THE ROADWAY STANDARD DRAWINGS.

APPROVED: *Michael T. Kewka* DATE: 1-3-08

SEAL

**FINAL PAVEMENT MARKING PLAN**

SCALE: NONE		<table border="1"> <tr><th colspan="2">REVISIONS</th></tr> <tr><td> </td><td> </td></tr> <tr><td> </td><td> </td></tr> <tr><td> </td><td> </td></tr> </table>	REVISIONS							
REVISIONS										
DATE: 12-07										
DWG. BY: BLM										
DESIGN BY: BLM										
REVIEWED BY: MTR	CADD FILE									

12/14/2007  
 P:\TIP\2320g\_ko\2320g\TrafficControl\TCF\000\AR2320G\_TC\_pmp7.dgn  
 KO & Associates, P.C.

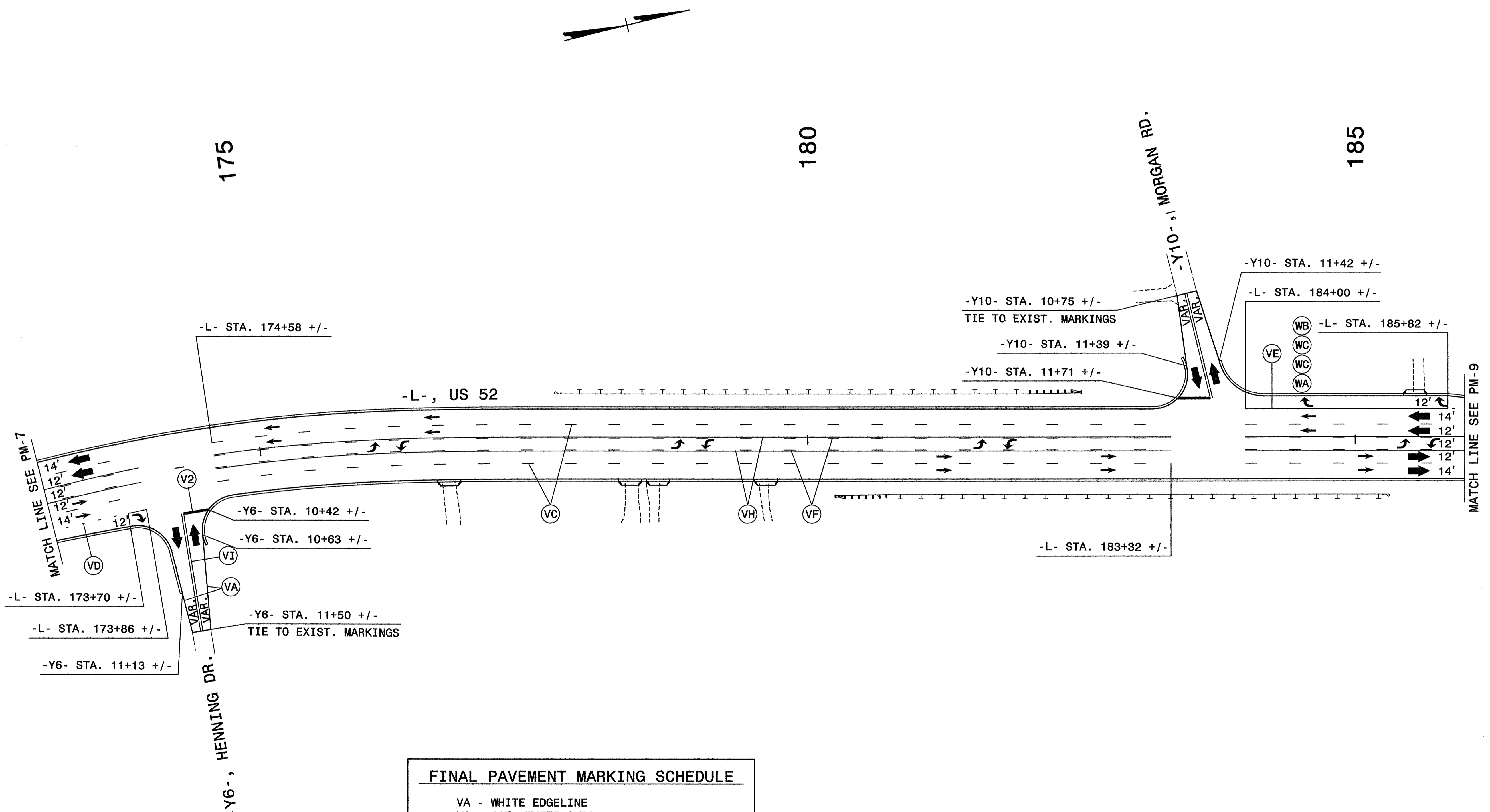

FINAL PAVEMENT MARKING SCHEDULE	
VA	- WHITE EDGELINE
VC	- 10ft WHITE SKIP
VD	- 2ft WHITE MINISKIP
VE	- WHITE SOLID LANE LINE
VF	- 10ft YELLOW SKIP
VH	- YELLOW SINGLE CENTER LINE
VI	- YELLOW DOUBLE CENTER LINE
V2	- WHITE STOPBAR
WA	- LEFT TURN ARROW
WB	- RIGHT TURN ARROW
WC	- STRAIGHT ARROW
WF	- COMBO LEFT / RIGHT TURN ARROW

**NOTES:**

- SEE SHEET PM-1, FOR FINAL PAVEMENT MARKING SCHEDULE.
- PAVEMENT MARKINGS, SYMBOLS, AND CHARACTERS ARE TO BE MARKED ACCORDING TO ROADWAY STANDARD DRAWINGS UNLESS OTHERWISE NOTED IN THE PLANS.
- PAVEMENT MARKERS ARE TO BE SPACED ACCORDING TO THE ROADWAY STANDARD DRAWINGS.

APPROVED: *Michael T. Kepp* DATE: 1-3-08

SEAL

**FINAL PAVEMENT MARKING PLAN**

SCALE: NONE		REVISIONS
DATE: 12-07		
DWG. BY: BLM		
DESIGN BY: BLM		
REVIEWED BY: MTR		

12/14/2007  
 P:\TIP\2320g\ko\2320g\TrafficControl\CP\002\2320G\_TC.pmp8.dgn  
 KO & Associates, P.C.



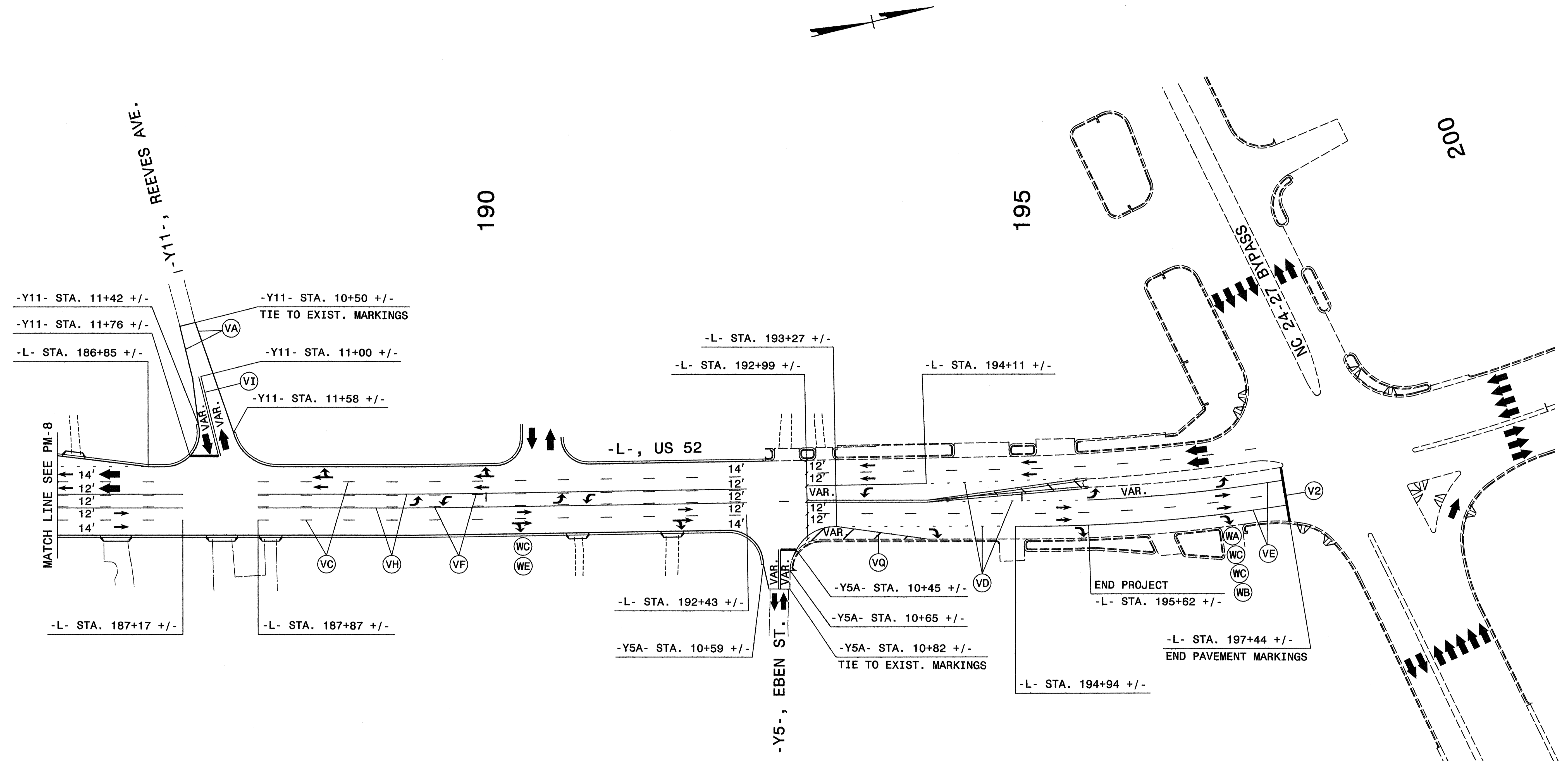

**FINAL PAVEMENT MARKING SCHEDULE**

- VA - WHITE EDGELINE
- VC - 10ft WHITE SKIP
- VD - 2ft WHITE MINISKIP
- VE - WHITE SOLID LANE LINE
- VF - 10ft YELLOW SKIP
- VH - YELLOW SINGLE CENTER LINE
- VI - YELLOW DOUBLE CENTER LINE
- VQ - WHITE DIAGONAL
- V2 - WHITE STOPBAR
- WA - LEFT TURN ARROW
- WB - RIGHT TURN ARROW
- WC - STRAIGHT ARROW
- WE - COMBO STRAIGHT / RIGHT TURN ARROW
- WF - COMBO LEFT / RIGHT TURN ARROW

**NOTES:**

- SEE SHEET PM-1, FOR FINAL PAVEMENT MARKING SCHEDULE.
- PAVEMENT MARKINGS, SYMBOLS, AND CHARACTERS ARE TO BE MARKED ACCORDING TO ROADWAY STANDARD DRAWINGS UNLESS OTHERWISE NOTED IN THE PLANS.
- PAVEMENT MARKERS ARE TO BE SPACED ACCORDING TO THE ROADWAY STANDARD DRAWINGS.

APPROVED: *Michael T. Rzepka* DATE: 1-3-08

SEAL

**FINAL PAVEMENT MARKING PLAN**

SCALE:	NONE		<b>REVISIONS</b> <table border="1"> <tr><td> </td><td> </td></tr> <tr><td> </td><td> </td></tr> <tr><td> </td><td> </td></tr> <tr><td> </td><td> </td></tr> </table>								
DATE:	12-07										
DWG. BY:	BLM										
DESIGN BY:	BLM										
REVIEWED BY:	MTR	CADD FILE									

12/14/2007  
 P:\TIP\2320g\_ko\2320g\TrafficControl\000\2320G\_TC\_pmp9.dgn  
 KO & Associates, P.C.