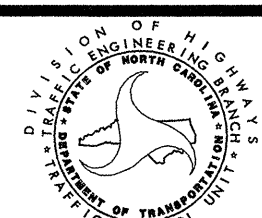
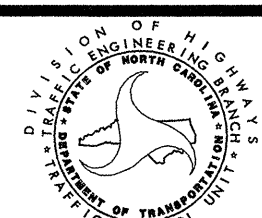
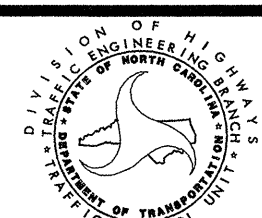

PAVEMENT MARKING SCHEDULE

SYMBOL	DESCRIPTION	PAY ITEM/QUANTITY BREAKDOWN	TOTAL QUANTITY
<u>PAVEMENT MARKING LINES</u>			
THERMOPLASTIC (4", 90 MILS)			
TA	WHITE EDGELINE	20,339 FT	
			TOTAL 20,339 FT
THERMOPLASTIC (4", 120 MILS)			
TD	2 FT. WHITE MINISKIP	507 FT	
TE	WHITE SOLID LANE LIN	600 FT	
TF	10 FT. YELLOW SKIP	3,429 FT	
TH	YELLOW SINGLE CENTER	12,668 FT	
TI	YELLOW DOUBLE CENTER	9,384 FT	
			TOTAL 26,588 FT
THERMOPLASTIC (8", 90 MILS)			
TT	YELLOW DIAGONAL	168 FT	
			TOTAL 168 FT
THERMOPLASTIC (24", 120 MILS)			
T2	WHITE TRANSVERSE BAND	72 FT	
			TOTAL 72 FT
PAINT (4")			
PA	WHITE EDGELINE	40,678 FT	
PD	2 FT. WHITE MINISKIP	1,014 FT	
PE	WHITE SOLID LANE LIN	1,200 FT	
PF	10 FT. YELLOW SKIP	6,858 FT	
PH	YELLOW SINGLE CENTER	25,336 FT	
PI	YELLOW DOUBLE CENTER	18,768 FT	
			TOTAL 93,854 FT
PAINT (8")			
PV	YELLOW DIAGONAL	336 FT	
			TOTAL 336 FT
PAINT (24")			
P4	WHITE TRANSVERSE BAND	72 FT	
			TOTAL 72 FT

SYMBOL	DESCRIPTION	PAY ITEM/QUANTITY BREAKDOWN	TOTAL QUANTITY
<u>PAVEMENT MARKING SYMBOLS</u>			
THERMOPLASTIC THICK SYMBOL (90 MILS)			
UA	LEFT TURN ARROW	78 EA	
			TOTAL 78 EA
THERMOPLASTIC THICK CHARACTER (120 MILS)			
UI	ALPHANUMERIC CHARACTER	12 EA	
			TOTAL 12 EA
PAINT SYMBOL			
QA	LEFT TURN ARROW	78 EA	
			TOTAL 78 EA
PAINT CHARACTER			
QI	ALPHANUMERIC CHARACTER	12 EA	
			TOTAL 12 EA
<u>PAVEMENT MARKERS</u>			
PERMANENT RAISED			
MA	YELLOW & YELLOW	266 EA	
MB	CRYSTAL & RED	96 EA	
			TOTAL 362 EA
TEMPORARY RAISED			
MH	YELLOW & YELLOW	266 EA	
MI	CRYSTAL & RED	96 EA	
			TOTAL 362 EA

12/6/2007 1:44:33 PM C:\P\X\m\w\k\ing\TPA\dms16829\US_301.PM-.l.dgn

APPROVED: <u>[Signature]</u> DATE: <u>12/28/07</u> 	<h2 style="margin: 0;">PAVEMENT MARKING SCHEDULE</h2>	<table border="1" style="width: 100%; border-collapse: collapse;"> <tr> <td>SCALE: NONE</td> <td rowspan="4" style="text-align: center;">  </td> <td>REVISIONS</td> </tr> <tr> <td>DATE: JULY 2006</td> <td></td> </tr> <tr> <td>DWG. BY: DHK</td> <td></td> </tr> <tr> <td>DESIGN BY: DHK</td> <td></td> </tr> <tr> <td>REVIEWED BY: LMP</td> <td></td> <td></td> </tr> </table>	SCALE: NONE		REVISIONS	DATE: JULY 2006		DWG. BY: DHK		DESIGN BY: DHK		REVIEWED BY: LMP		
SCALE: NONE		REVISIONS												
DATE: JULY 2006														
DWG. BY: DHK														
DESIGN BY: DHK														
REVIEWED BY: LMP														



20

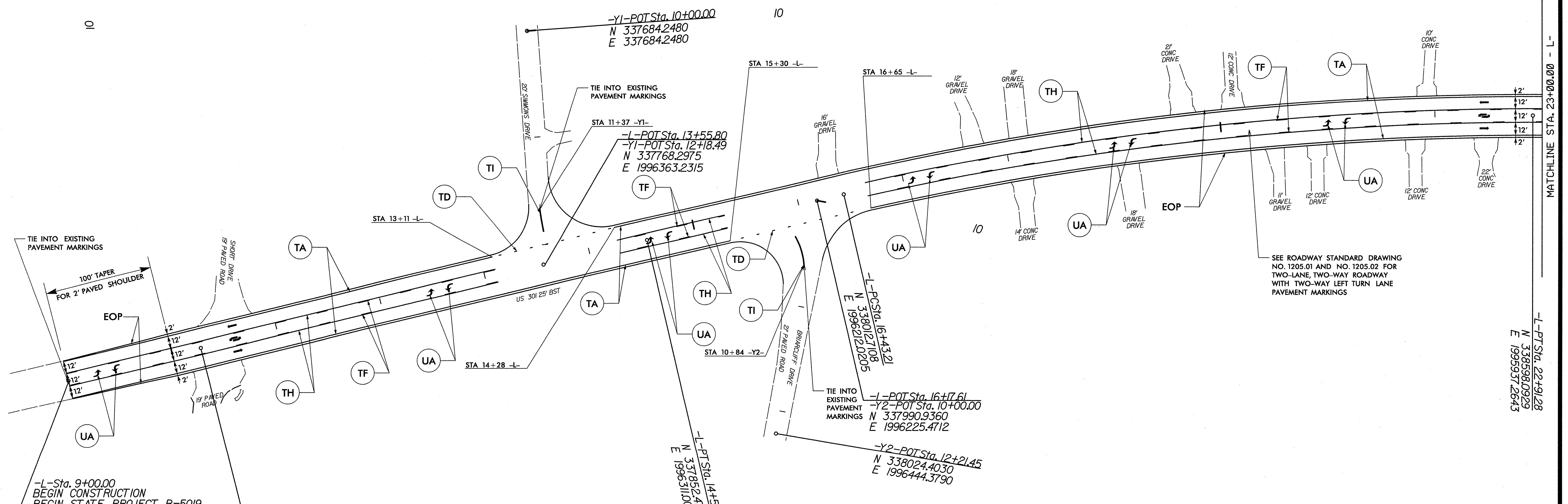

-L- Sta. 9+00.00
 BEGIN CONSTRUCTION
 BEGIN STATE PROJECT R-5019
 N 337383.5408
 E 1996607.5855

-L- Post Sta. 10+27.13
 N 337490.5303
 E 1996534.9176

-Y1- POT Sta. 10+00.00
 N 337684.2480
 E 337684.2480

-L- POT Sta. 13+55.80
 -Y1- POT Sta. 12+18.49
 N 337768.2975
 E 1996363.2315

-L- Post Sta. 16+43.21
 N 338021.108
 E 1996212.0205

-L- POT Sta. 16+17.61
 -Y2- POT Sta. 10+00.00
 N 337990.9360
 E 1996225.4712

-Y2- POT Sta. 12+21.45
 N 338024.4030
 E 1996444.3790

-L- PT Sta. 14+54.86
 N 337852.4719
 E 1996311.0029

-L- PT Sta. 22+91.28
 N 338598.0929
 E 1995937.2643

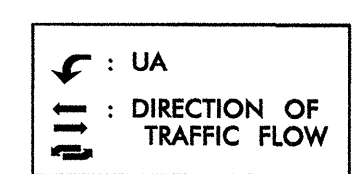

SEE SHEET PM-1 FOR MARKING SCHEDULE.
 SEE ROADWAY STANDARD DRAWING NO. 1250.01 AND 1251.01 FOR PAVEMENT MARKER SPACING AND RAISED PAVEMENT MARKERS.

APPROVED: <i>[Signature]</i> DATE: 2/2/08	PAVEMENT MARKINGS	
	SCALE: 1" = 50'	
	DATE: JULY 2006	
	DWG. BY: DHK	
	DESIGN BY: DHK	
REVIEWED BY: LMP	REVISIONS	

2/21/2008 3:53:05 PM C:\PW\X\mwork\king\TPA\dms18829\US_301.PM_2.dgn

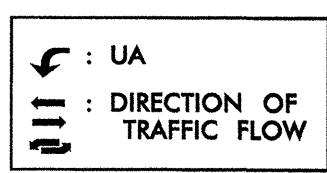
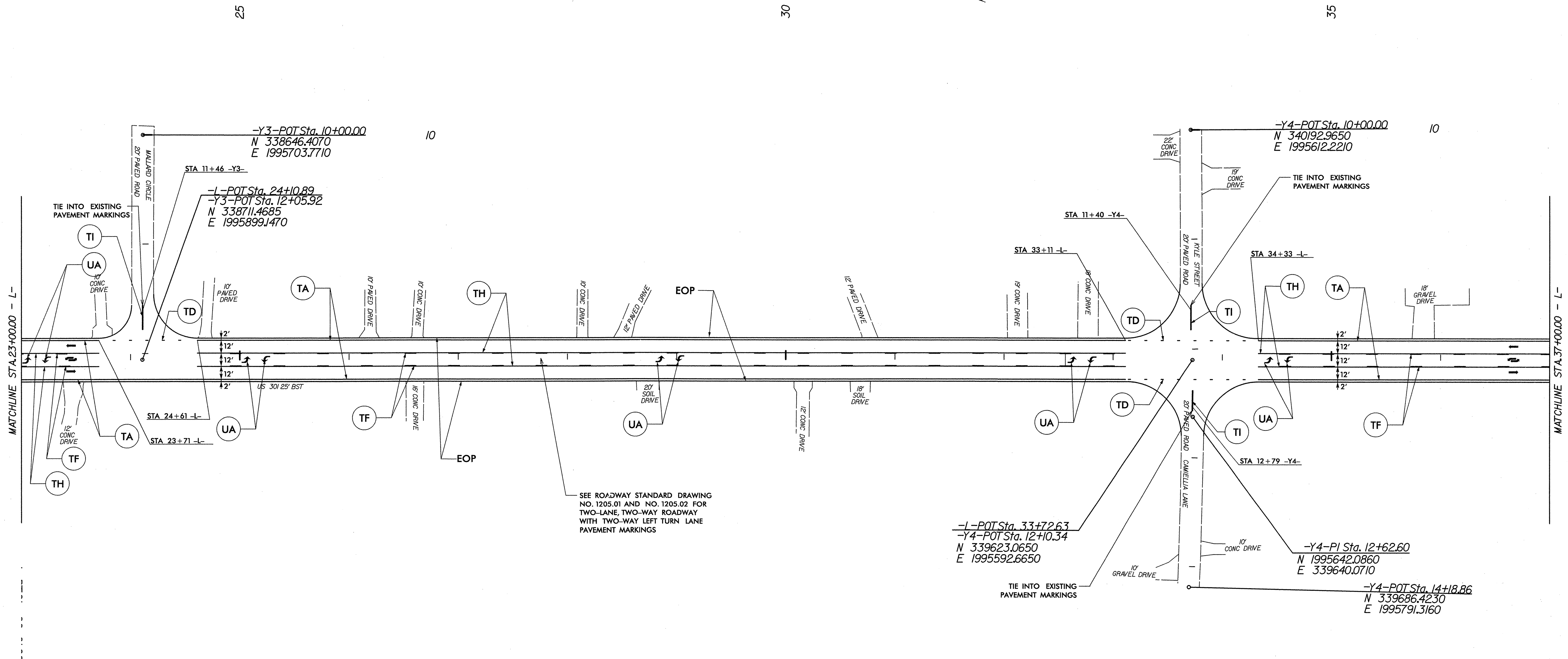

APPROVED: <i>[Signature]</i> DATE: 7/26/06	PAVEMENT MARKINGS									
SCALE: 1" = 50'	DATE: JULY 2006	<table border="1"> <thead> <tr> <th colspan="2">REVISIONS</th> </tr> </thead> <tbody> <tr> <td> </td> <td> </td> </tr> <tr> <td> </td> <td> </td> </tr> <tr> <td> </td> <td> </td> </tr> </tbody> </table>	REVISIONS							
REVISIONS										
DWG. BY: DHK	DESIGN BY: DHK									
REVIEWED BY: LMP										

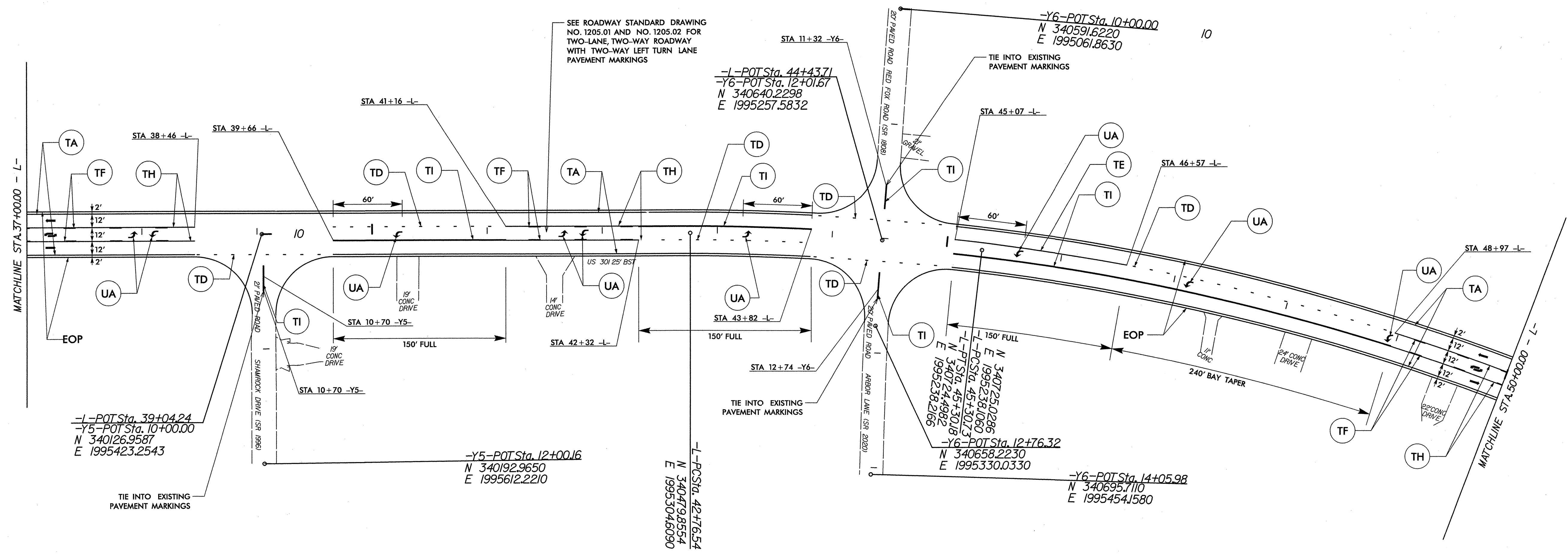

2/23/2008 3:34 PM C:\PWX\work\ind\TPA\dms16829\US_301_P.M.-4.dgn

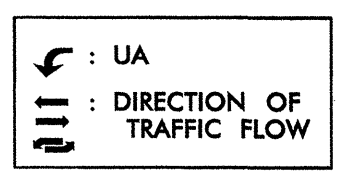

SEE SHEET PM-1 FOR MARKING SCHEDULE.
 SEE ROADWAY STANDARD DRAWING NO. 1250.01 AND 1251.01 FOR PAVEMENT MARKER SPACING AND RAISED PAVEMENT MARKERS.

APPROVED: <i>[Signature]</i> DATE: 7/2/06	PAVEMENT MARKINGS				<table border="1"> <tr><th>REVISIONS</th></tr> <tr><td> </td></tr> <tr><td> </td></tr> <tr><td> </td></tr> <tr><td> </td></tr> </table>	REVISIONS				
REVISIONS										
<table border="1"> <tr><td>SCALE: 1" = 50'</td></tr> <tr><td>DATE: JULY 2006</td></tr> <tr><td>DWG. BY: DHK</td></tr> <tr><td>DESIGN BY: DHK</td></tr> <tr><td>REVIEWED BY: LMP</td></tr> </table>	SCALE: 1" = 50'	DATE: JULY 2006	DWG. BY: DHK	DESIGN BY: DHK	REVIEWED BY: LMP					
SCALE: 1" = 50'										
DATE: JULY 2006										
DWG. BY: DHK										
DESIGN BY: DHK										
REVIEWED BY: LMP										

50

55

60

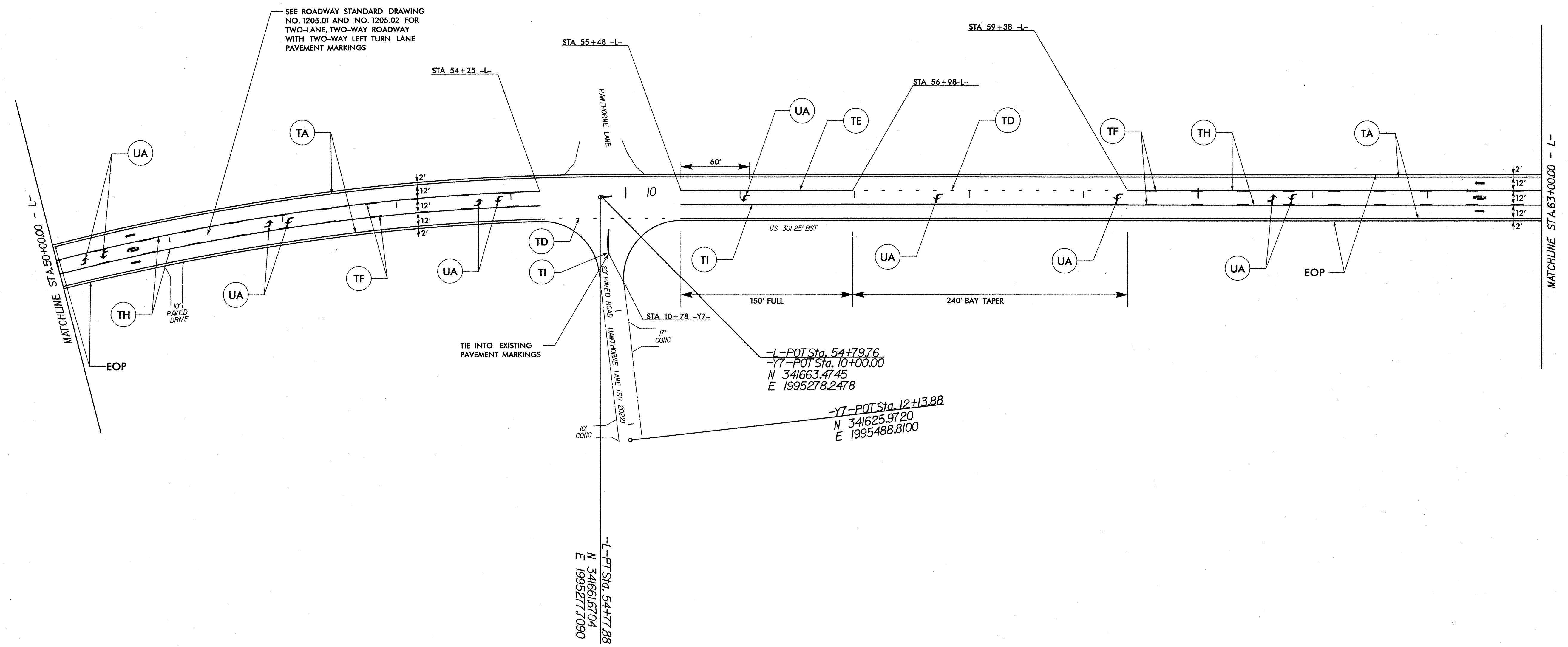
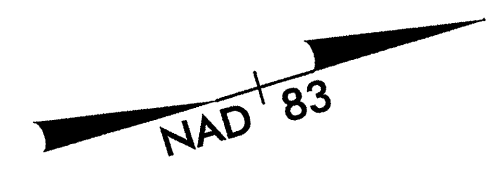

-1-PT Sta. 54+79.76
 -Y7-PT Sta. 10+00.00
 N 341663.4745
 E 1995278.2478

-Y7-PT Sta. 12+13.88
 N 341625.9720
 E 1995488.8100

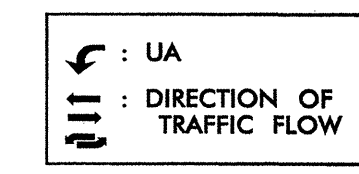

SEE SHEET PM-1 FOR MARKING SCHEDULE.
 SEE ROADWAY STANDARD DRAWING NO. 1250.01 AND 1251.01 FOR PAVEMENT MARKER SPACING AND RAISED PAVEMENT MARKERS.

APPROVED: <i>[Signature]</i> DATE: 2/21/06		PAVEMENT MARKINGS	
SCALE: 1" = 50'	DATE: JULY 2006		REVISIONS
DWG. BY: DHK	DESIGN BY: DHK		
REVIEWED BY: LMP			

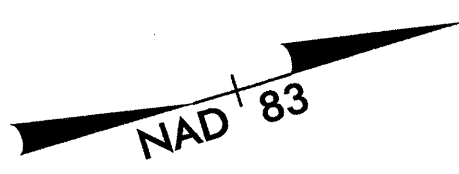

65

70

75

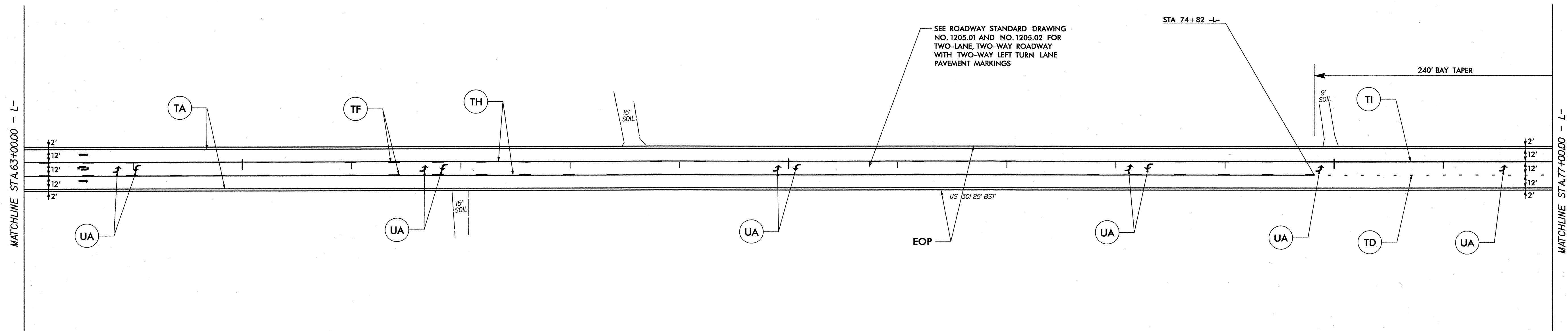

2/21/2008
 3:53:26 PM
 C:\P\W\Wor-King\TPA\dms16829\US_301.PM_6.dgn

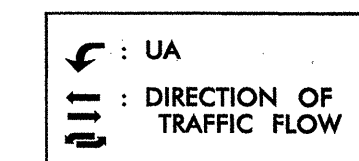

SEE SHEET PM-1 FOR MARKING SCHEDULE.
 SEE ROADWAY STANDARD DRAWING NO. 1250.01 AND 1251.01 FOR PAVEMENT MARKER SPACING AND RAISED PAVEMENT MARKERS.

APPROVED: <i>[Signature]</i> DATE: 2/26/08		PAVEMENT MARKINGS									
				SCALE: 1" = 50'	<table border="1"> <thead> <tr> <th colspan="2">REVISIONS</th> </tr> </thead> <tbody> <tr> <td> </td> <td> </td> </tr> <tr> <td> </td> <td> </td> </tr> <tr> <td> </td> <td> </td> </tr> </tbody> </table>	REVISIONS					
		REVISIONS									
DATE: JULY 2006		DWG. BY: DHK									
DESIGN BY: DHK		REVIEWED BY: LMP									
REVIEWED BY: LMP		CADD FILE									

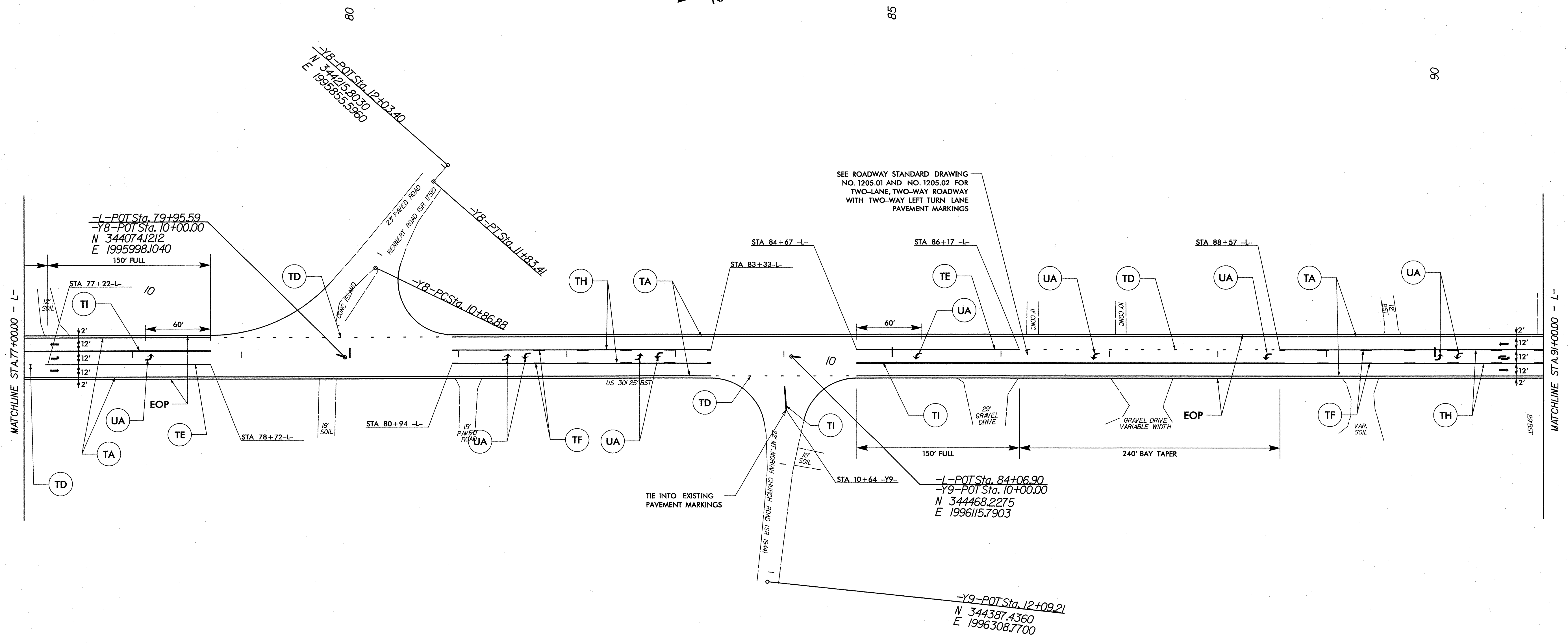

-L-POT Sta. 79+95.59
-Y8-POT Sta. 10+00.00
N 344074.1212
E 1995998.1040
150' FULL

SEE ROADWAY STANDARD DRAWING
NO. 1205.01 AND NO. 1205.02 FOR
TWO-LANE, TWO-WAY ROADWAY
WITH TWO-WAY LEFT TURN LANE
PAVEMENT MARKINGS

-L-POT Sta. 84+06.90
-Y9-POT Sta. 10+00.00
N 344468.2275
E 1996115.7903

-Y9-POT Sta. 12+09.21
N 344387.4360
E 1996308.7700

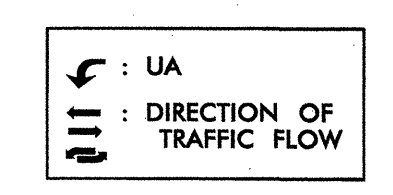

SEE SHEET PM-1 FOR MARKING SCHEDULE.
SEE ROADWAY STANDARD DRAWING NO.
1250.01 AND 1251.01 FOR PAVEMENT MARKER
SPACING AND RAISED PAVEMENT MARKERS.

APPROVED: <i>[Signature]</i> DATE: 7/2/06	PAVEMENT MARKINGS									
SCALE: 1" = 50'	DATE: JULY 2006	<table border="1"> <thead> <tr> <th colspan="2">REVISIONS</th> </tr> </thead> <tbody> <tr> <td> </td> <td> </td> </tr> <tr> <td> </td> <td> </td> </tr> <tr> <td> </td> <td> </td> </tr> </tbody> </table>	REVISIONS							
REVISIONS										
DWG. BY: DHK	DESIGN BY: DHK									
REVIEWED BY: LMP										

2/21/2008 3:33:30 PM
 C:\PWX\mwork\king\TPA\dmsis\6829\US_301-PM-7.dgn



95

100

105

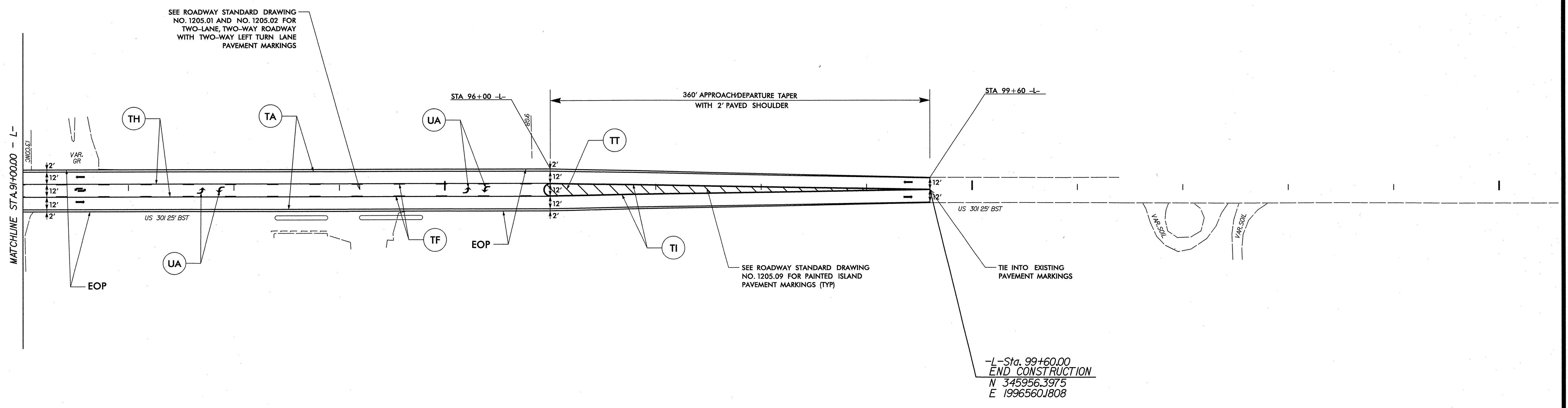

2/21/2008 3:33:35 PM C:\PWX\work\king\TPA\dms\6829\US_301.PM_B.dgn

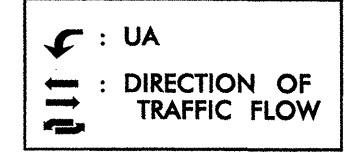

SEE SHEET PM-1 FOR MARKING SCHEDULE.
SEE ROADWAY STANDARD DRAWING NO. 1250.01 AND 1251.01 FOR PAVEMENT MARKER SPACING AND RAISED PAVEMENT MARKERS.

APPROVED: <i>Lisa M. Podetz</i> DATE: 7/21/08 	PAVEMENT MARKINGS							
SCALE: 1" = 50' DATE: JULY 2006 DWG. BY: DHK DESIGN BY: DHK REVIEWED BY: LMP		REVISIONS <table border="1"> <tr><td> </td><td> </td></tr> <tr><td> </td><td> </td></tr> <tr><td> </td><td> </td></tr> </table>						

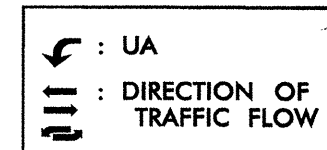
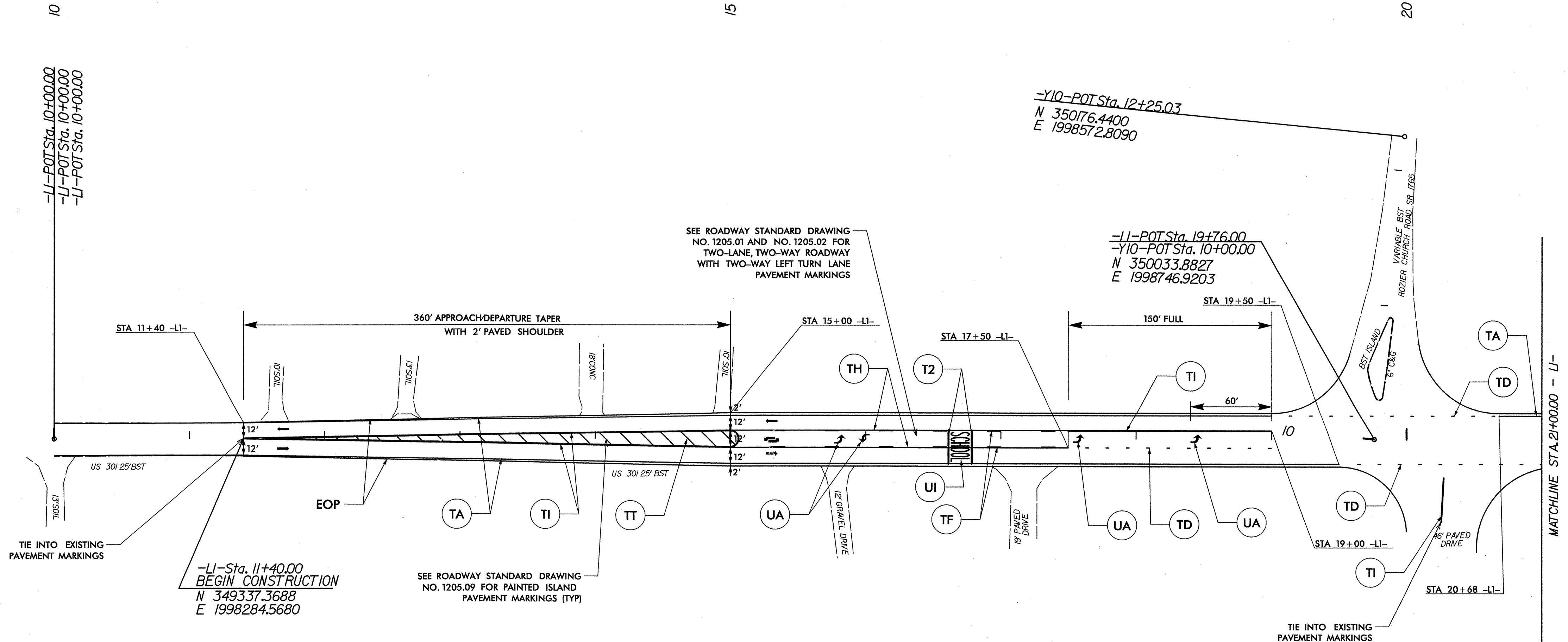
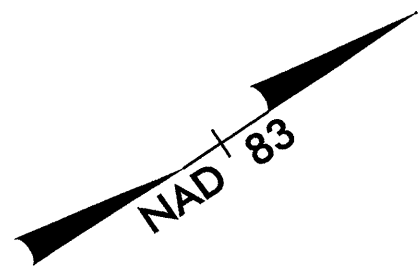

SEE SHEET PM-1 FOR MARKING SCHEDULE.
 SEE ROADWAY STANDARD DRAWING NO. 1250.01 AND 1251.01 FOR PAVEMENT MARKER SPACING AND RAISED PAVEMENT MARKERS.

APPROVED: <i>[Signature]</i> DATE: 7/2/06	PAVEMENT MARKINGS									
SCALE: 1" = 50' DATE: JULY 2006 DWG. BY: DHK DESIGN BY: DHK REVIEWED BY: LMP		REVISIONS <table border="1"> <tr><td> </td><td> </td></tr> <tr><td> </td><td> </td></tr> <tr><td> </td><td> </td></tr> <tr><td> </td><td> </td></tr> </table>								

2/21/2008 3:33:40 PM C:\P\Xmwork\king\TPA\dms16829\US_301.PM_9.dgn

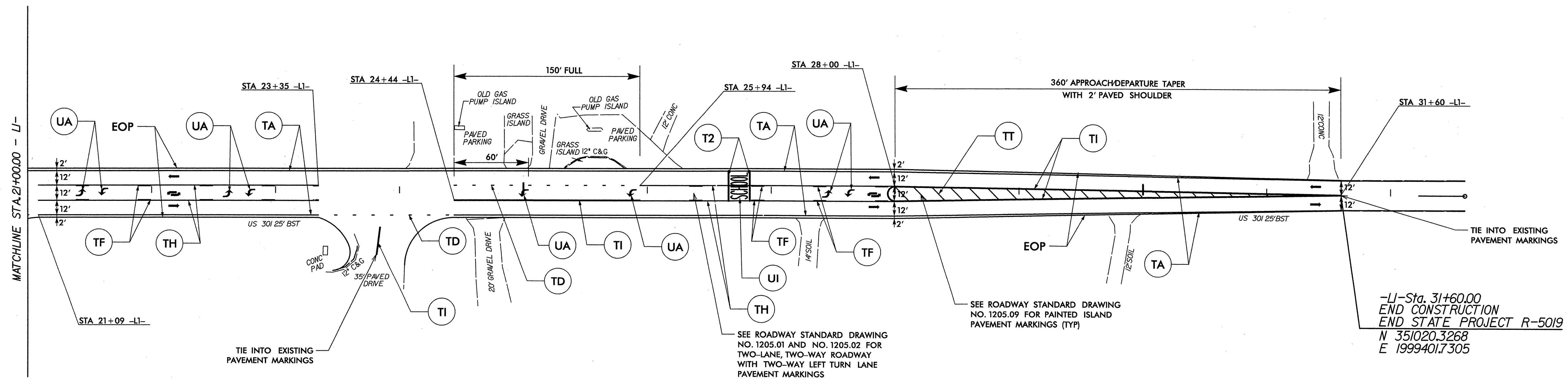
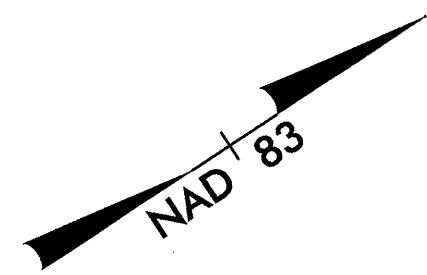

-LI- Sta. 31+60.00
 END CONSTRUCTION
 END STATE PROJECT R-5019
 N 351020.3268
 E 1999401.7305

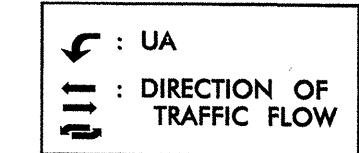

SEE SHEET PM-1 FOR MARKING SCHEDULE.
 SEE ROADWAY STANDARD DRAWING NO. 1250.01 AND 1251.01 FOR PAVEMENT MARKER SPACING AND RAISED PAVEMENT MARKERS.

APPROVED: *Lisa M. Pote* DATE: 7/26/06



PAVEMENT MARKINGS

SCALE: 1" = 50'
 DATE: JULY 2006
 DWG. BY: DHK
 DESIGN BY: DHK
 REVIEWED BY: LMP



NO.	REVISIONS