

FINAL PAVEMENT MARKING SCHEDULE

SYMBOL	DESCRIPTION
FINAL PAVEMENT MARKINGS	
PAINT(4")	
PA	WHITE EDGELINE (2X)
PC	10 FT. WHITE SKIP (2X)
PD	2 FT. WHITE MINISKIP (2X)
PE	WHITE SOLID LANE LINE (2X)
PF	10 FT. YELLOW SKIP (2X)
PH	YELLOW SINGLE CENTER (2X)
PI	YELLOW DOUBLE CENTER (2X)
PAINT(24") FINAL PAVEMENT MARKING	
P4	WHITE STOPBAR (2X)
PAINT MARKING SYMBOLS	
QA	LEFT TURN ARROW (2X)
QC	STRAIGHT ARROW (2X)
QE	COMBO.STRAIGHT/RIGHT (2X)
THERMOPLASTIC(4", 90 MILS)	
TA	WHITE EDGELINE
THERMOPLASTIC(4", 120 MILS)	
TC	10 FT. WHITE SKIP
TD	2 FT. WHITE MINISKIP
TE	WHITE SOLID LANE LINE
TH	YELLOW SINGLE CENTER
TI	YELLOW DOUBLE CENTER
THERMOPLASTIC(8", 90 MILS)	
TT	YELLOW DIAGONAL
THERMOPLASTIC(16", 120 MILS)	
T1	WHITE LINE, RR CROSSB
THERMOPLASTIC(24", 120 MILS)	
T2	WHITE STOPBAR
THERMOPLASTIC PAVEMENT MARKING SYMBOLS (90 MILS)	
UA	LEFT TURN ARROW
UB	RIGHT TURN ARROW
UC	STRAIGHT ARROW
UE	COMBO.STRAIGHT/RIGHT
THERMOPLASTIC PAVEMENT MARKING 'R x R' CHARACTER (120 MILS)	
UI	ALPHANUMERIC CHAR.

23-JAN-2008 07:39
 \\dot\dfsroot\on\Pro\TIP\Projects-U\U2702\traffic\trafficcontrol\top\PM\U-2702-Tc-Tc-PMP_01.dgn
 anayes AT WZTC22424

APPROVED: _____	DATE: _____	FINAL PAVEMENT MARKING SCHEDULE	
	SCALE: NONE		REVISIONS
	DATE: 02/07		
	DWG. BY: DAH		
	DESIGN BY: DAH		
REVIEWED BY: JWW			

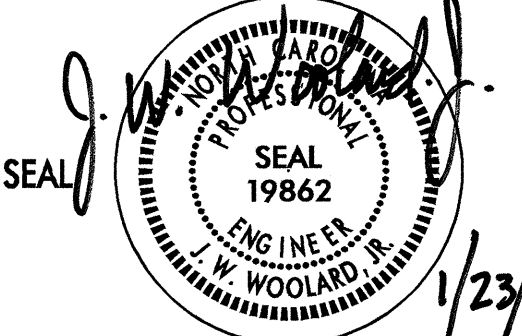
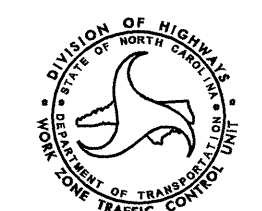
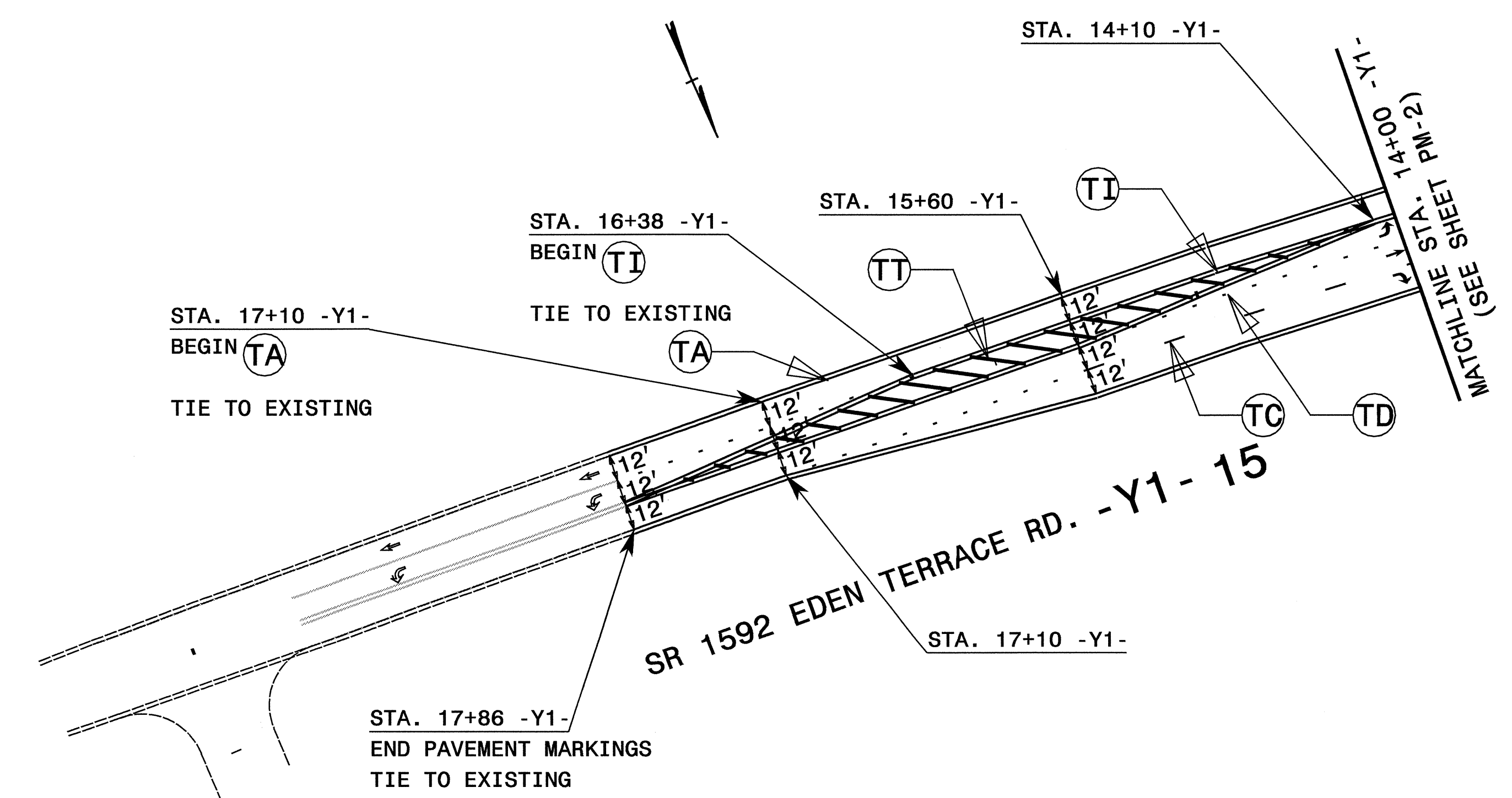
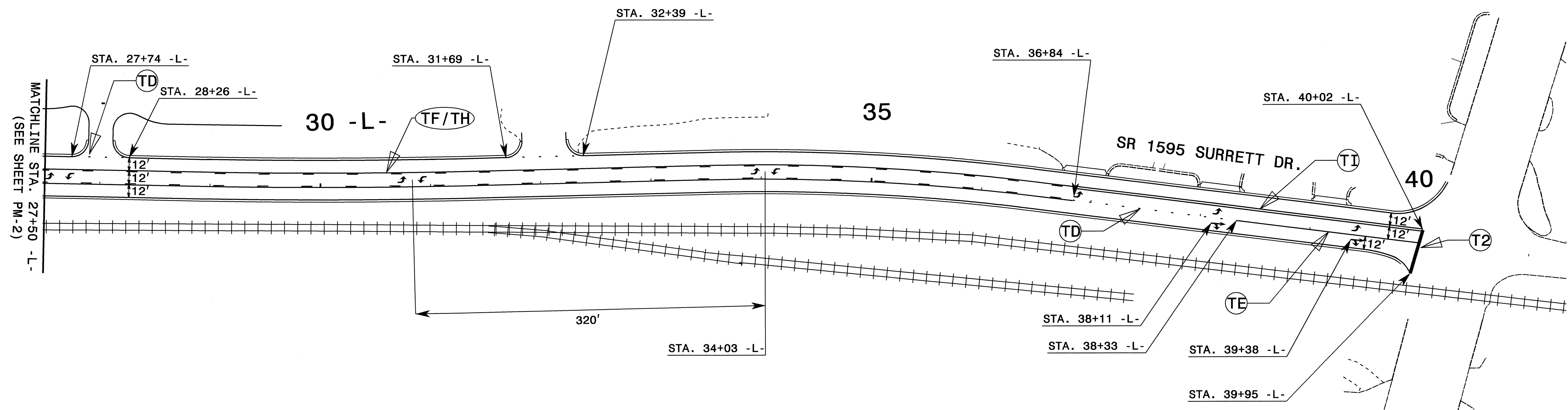

- : PROPOSED PAVEMENT MARKING LINE
- - - : EXISTING PAVEMENT MARKING LINE
- ↖ : UA ↗ : UD ↕ : UG
- ↘ : UB ↙ : UE
- : UC ← : UF
- ↻ : EXISTING PAVEMENT MARKING SYMBOL

TA	WHITE EDGELINE
TC	10 FT. WHITE SKIP
TD	2 FT. WHITE MINISKIP
TE	WHITE SOLID LANE LINE
TH	YELLOW SINGLE CENTER
TI	YELLOW DOUBLE CENTER
TT	YELLOW DIAGONAL
T1	WHITE LINE, RR CROSSB
T2	WHITE STOPBAR

APPROVED: _____	DATE: _____	FINAL PAVEMENT MARKING PLANS	
SCALE: NONE	DATE: 02/07		REVISIONS
DWG. BY: DAH	DESIGN BY: DAH		
REVIEWED BY: JWW			

23-JAN-2008 07:38
 \\dot\dfs\dot\on\Proj\TIP\Projects-U\U2702\Traffic\TrafficControl\top\PM\U-2702_TC-PMP-03.dgn
 andyes AT WZ1C22424