

See Sheet 1-A For Index of Sheets
See Sheet 1-B For Conventional Symbols

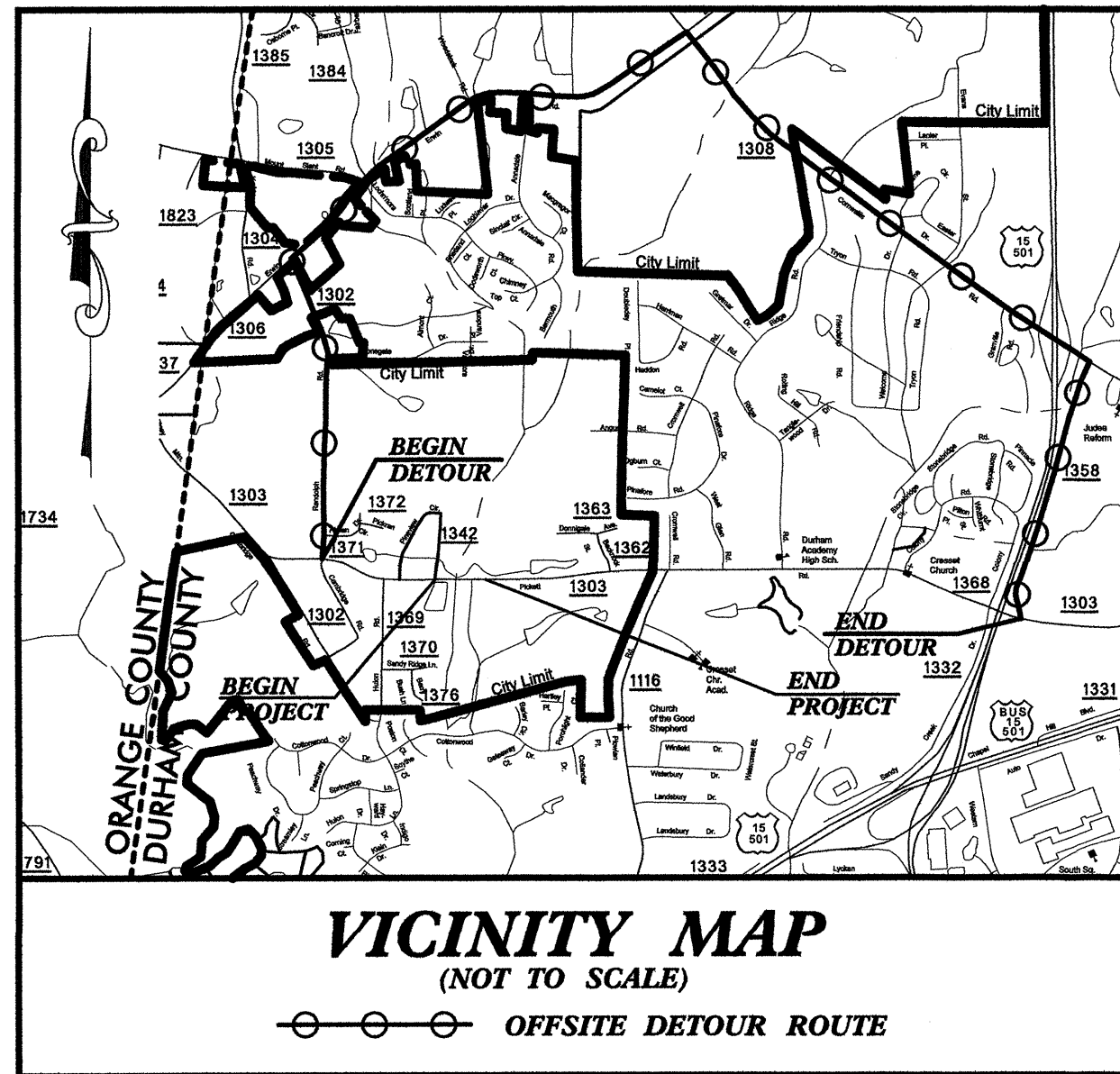

STATE OF NORTH CAROLINA
DIVISION OF HIGHWAYS

DURHAM COUNTY

**LOCATION: BRIDGE NO. 120 OVER MUD CREEK
ON SR 1303 IN DURHAM**

TYPE OF WORK: GRADING, DRAINAGE, PAVING, AND STRUCTURE

STATE	STATE PROJECT REFERENCE NO.	SHEET NO.	TOTAL SHEETS
N.C.	B-4109	1	
WBS NO.	F.A. PROJ. NO.	DESCRIPTION	
33464.1.1	BRZ-1303(3)	P.E.	
33464.2.1	BRZ-1303(3)	RW, UTIL	
33464.3.1	BRZ-1303(3)	CONST	

TIP: B-4109

CONTRACT: C201834

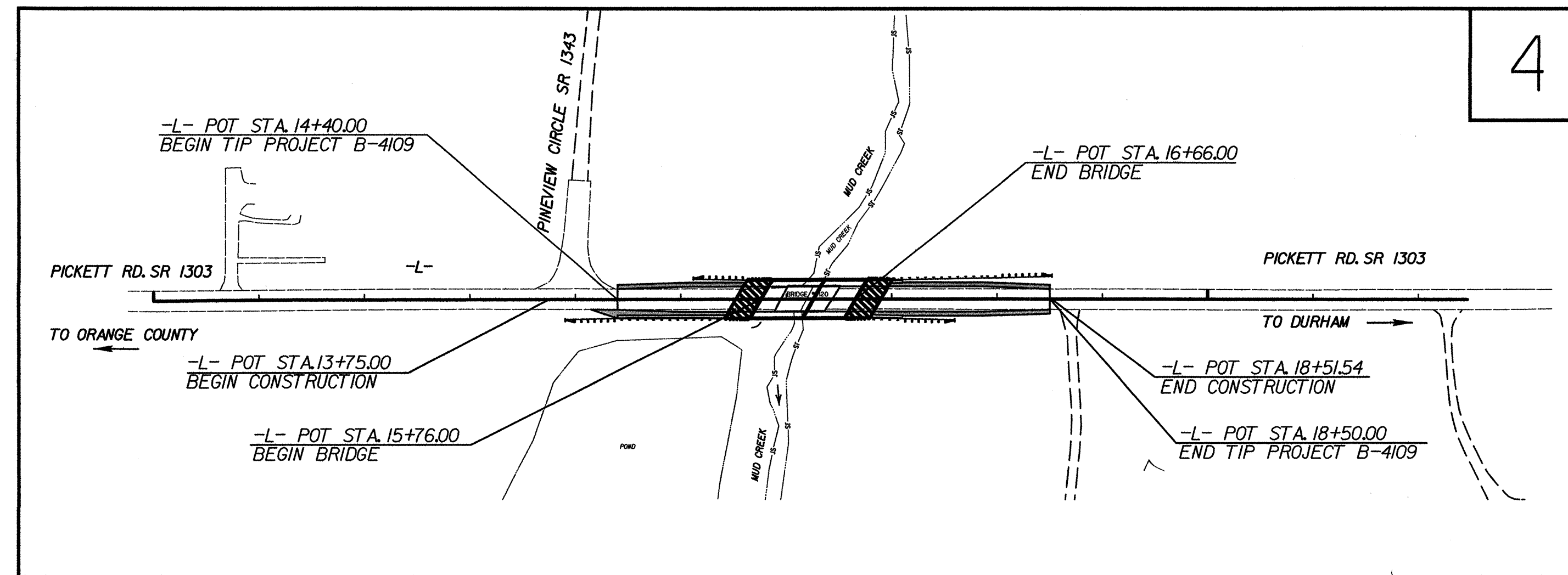

MULKEY
ENGINEERS & CONSULTANTS

PO Box 33127
RALEIGH, N.C. 27636
(919) 851-1912
(919) 851-1918 (FAX)
WWW.MULKEYINC.COM

NCDOT CONTACT : DOUG TAYLOR, PE
PROJECT ENGINEER - ROADWAY DESIGN

GRAPHIC SCALES

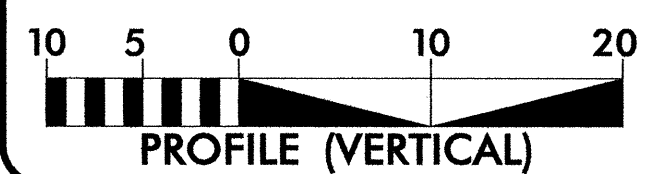
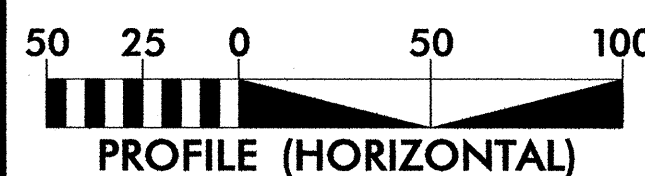
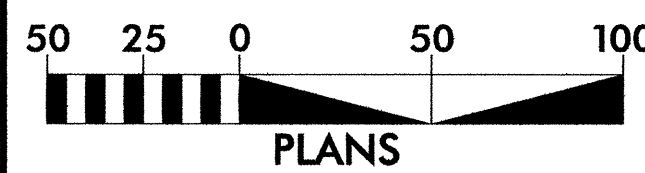

DESIGN DATA

ADT 2008 = 6,100
ADT 2030 = 12,400
DHV = 13 %
D = 60 %
T = 3 % *
V = 40 MPH
FUNCTION. = URBAN
CLASS. LOCAL
* (TTST 1% + DUALS 2%)

PROJECT LENGTH

LENGTH ROADWAY TIP PROJECT B-4109 = 0.061 MI
LENGTH STRUCTURE TIP PROJECT B-4109 = 0.017 MI
TOTAL LENGTH TIP PROJECT B-4109 = 0.078 MI

Prepared In the Office of:
MULKEY ENGINEERS & CONSULTANTS
FOR THE NORTH CAROLINA DEPT. OF TRANSPORTATION

2006 STANDARD SPECIFICATIONS

RIGHT OF WAY DATE:
MAY 18, 2007

LETTING DATE:
MAY 20, 2008

TIM S. HAYES, PE
PROJECT ENGINEER

JOHNNY R. BANKS
PROJECT MANAGER

HYDRAULICS ENGINEER

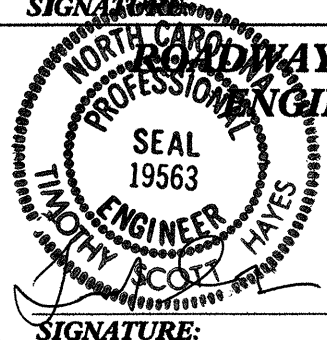

3-6-08 P.E.

2/2/08 P.E.

DIVISION OF HIGHWAYS
STATE OF NORTH CAROLINA

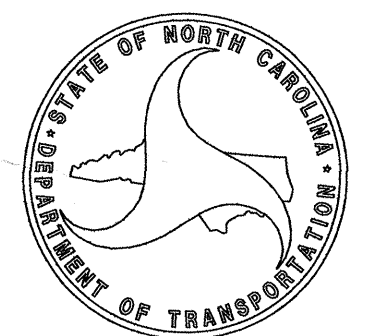

STATE HIGHWAY DESIGN ENGINEER

Index of Sheets, General Notes, and List of Standards

EFF. 07-18-06
REV. 01-02-07

INDEX OF SHEETS:

Sheet #	Description
1	Title Sheet
1-A	Index of Sheets, General Notes, and List of Standards
1-B	Conventional Symbols
1-C	Survey Control Sheet
2	Pavement Schedule, Wedging Detail, and Typical Sections
2-A	Typical Sections
2-B	Anchorage For Frames
3	Summary of Quantities
3-A	List of Pipe, Endwalls, Etc. (For Pipes 48" & Under) and Guardrail Summary
3-B	Summary of Earthwork in Cubic Yards, Summary of Pavement Removal Plan and Profile
4	Traffic Control Plans
TCP-1 thru TCP-4	Special Sign Design
SD-1	Erosion Control Plans
EC-1 thru EC-4	Signal Plans
SIG-1 thru SIG-9	Utility Construction Plans
UC-1 thru UC-9	Utilities By Others Plans
UO-1 thru UO-2	Cross-Section Summary Sheet
EW-Volume-1	Cross-Sections
X-1 thru X-4	Structure Plans
S-1 thru S-24	

GENERAL NOTES: 2006 SPECIFICATIONS
EFFECTIVE: 07-18-06
REVISED: 07-18-06

GRADING AND SURFACING OR RESURFACING AND WIDENING:
THE GRADE LINES SHOWN DENOTE THE FINISHED ELEVATION OF THE PROPOSED SURFACING AT GRADE POINTS SHOWN ON THE TYPICAL SECTIONS. WHERE NO GRADE LINES ARE SHOWN, THE PROFILES SHOWN DENOTE THE TOP ELEVATION OF THE EXISTING PAVEMENT ALONG THE CENTER LINE OF SURVEY ON WHICH THE PROPOSED RESURFACING WILL BE PLACED. GRADE LINES MAY BE ADJUSTED BY THE ENGINEER IN ORDER TO SECURE A PROPER TIE-IN.

CLEARING:
CLEARING ON THIS PROJECT SHALL BE PERFORMED TO THE LIMITS ESTABLISHED BY METHOD III.

SIDE ROADS:
THE CONTRACTOR WILL BE REQUIRED TO DO ALL NECESSARY WORK TO PROVIDE SUITABLE CONNECTIONS WITH ALL ROADS, STREETS, AND DRIVES ENTERING THIS PROJECT. THIS WORK WILL BE PAID FOR AT THE CONTRACT UNIT PRICE FOR THE PARTICULAR ITEMS INVOLVED.

GUARDRAIL:
THE GUARDRAIL LOCATIONS SHOWN ON THE PLANS MAY BE ADJUSTED DURING CONSTRUCTION AS DIRECTED BY THE ENGINEER. THE CONTRACTOR SHOULD CONSULT WITH THE ENGINEER PRIOR TO ORDERING GUARDRAIL MATERIAL.

SUBSURFACE PLANS:
NO SUBSURFACE PLANS ARE AVAILABLE ON THIS PROJECT. THE CONTRACTOR SHOULD MAKE HIS OWN INVESTIGATION AS TO THE SUBSURFACE CONDITIONS.

END BENTS:
THE ENGINEER SHALL CHECK THE STRUCTURE END BENT PLANS, DETAILS, AND CROSS-SECTION PRIOR TO SETTING OF THE SLOPE STAKES FOR THE EMBANKMENT OR EXCAVATION APPROACHING A BRIDGE.

UTILITIES:
UTILITY OWNERS ON THIS PROJECT ARE PSNC ENERGY, TIME WARNER CABLE, DUKE ENERGY, VERIZON, CITY OF DURHAM.

RIGHT-OF-WAY MARKERS:
ALL RIGHT-OF-WAY MARKERS ON THIS PROJECT SHALL BE PLACED BY CONTRACT.

2006 ROADWAY ENGLISH STANDARD DRAWINGS

The following Roadway Standards as appear in "Roadway Standard Drawings" Highway Design Branch - N. C. Department of Transportation - Raleigh, N. C., Dated July 18, 2006 are applicable to this project and by reference hereby are considered a part of these plans:

STD. NO.	TITLE
DIVISION 2 - EARTHWORK	
200.03	Method of Clearing - Method III
225.02	Guide for Grading Subgrade - Secondary and Local
225.04	Method of Obtaining Superelevation - Two Lane Pavement
DIVISION 3 - PIPE CULVERTS	
300.01	Method of Pipe Installation - Method 'A'
310.10	Driveway Pipe Construction
DIVISION 4 - MAJOR STRUCTURES	
422.10	Reinforced Bridge Approach Fills
DIVISION 5 - SUBGRADE, BASES AND SHOULDERS	
560.01	Method of Shoulder Construction - High Side of Superelevated Curve - Method I
DIVISION 6 - ASPHALT BASES AND PAVEMENTS	
654.01	Pavement Repairs
DIVISION 8 - INCIDENTALS	
806.01	Concrete Right-of-Way Marker
840.18	Concrete Grated Drop Inlet Type 'B' - 12" thru 36" Pipe
840.24	Frames and Narrow Slot Sag Grates
840.27	Brick Grated Drop Inlet Type 'B' - 12" thru 36" Pipe
840.29	Frames and Narrow Slot Flat Grates
840.45	Precast Drainage Structure
840.54	Manhole Frame and Cover
840.66	Drainage Structure Steps
846.01	Concrete Curb, Gutter and Curb & Gutter
846.04	Drop Inlet Installation in Shoulder Berm Gutter
862.01	Guardrail Placement
862.02	Guardrail Installation
862.03	Structure Anchor Units
876.02	Guide for Rip Rap at Pipe Outlets

REVISIONS

Note: Not to Scale

*S.U.E. = Subsurface Utility Engineering













MULKEY
ENGINEERS & CONSULTANTS
PO Box 32127
Raleigh, N.C. 27636
(919) 851-1912
(919) 851-1918 FAX
WWW.MULKEYINC.COM

PROJECT REFERENCE NO.	SHEET NO.
B-4109	I-B
RW SHEET NO.	











STATE OF NORTH CAROLINA
DIVISION OF HIGHWAYS

CONVENTIONAL SYMBOLS









BOUNDARIES AND PROPERTY:

State Line	_____
County Line	_____
Township Line	_____
City Line	_____
Reservation Line	_____
Property Line	_____
Existing Iron Pin	_____ 
Property Corner	_____ 
Property Monument	_____ 
Parcel/Sequence Number	_____ 
Existing Fence Line	_____ 
Proposed Woven Wire Fence	_____ 
Proposed Chain Link Fence	_____ 
Proposed Barbed Wire Fence	_____ 
Existing Wetland Boundary	_____ 
Proposed Wetland Boundary	_____ 
Existing Endangered Animal Boundary	_____ 
Existing Endangered Plant Boundary	_____ 



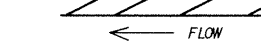

BUILDINGS AND OTHER CULTURE:

Gas Pump Vent or U/G Tank Cap	_____ 
Sign	_____ 
Well	_____ 
Small Mine	_____ 
Foundation	_____ 
Area Outline	_____ 
Cemetery	_____ 
Building	_____ 
School	_____ 
Church	_____ 
Dam	_____ 







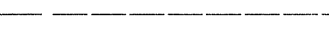





HYDROLOGY:

Stream or Body of Water	_____
Hydro, Pool or Reservoir	_____ 
Jurisdictional Stream	_____ 
Buffer Zone 1	_____
Buffer Zone 2	_____
Flow Arrow	_____ 
Disappearing Stream	_____ 
Spring	_____ 
Wetland	_____ 
Proposed Lateral, Tail, Head Ditch	_____ 
False Sump	_____ 











RAILROADS:

Standard Gauge	_____ 
RR Signal Milepost	_____ 
Switch	_____ 
RR Abandoned	_____ 
RR Dismantled	_____ 







RIGHT OF WAY:

Baseline Control Point	_____ 
Existing Right of Way Marker	_____ 
Existing Right of Way Line	_____ 
Proposed Right of Way Line	_____ 
Proposed Right of Way Line with Iron Pin and Cap Marker	_____ 
Proposed Right of Way Line with Concrete or Granite Marker	_____ 
Existing Control of Access	_____ 
Proposed Control of Access	_____ 
Existing Easement Line	_____ 
Proposed Temporary Construction Easement	_____ 
Proposed Temporary Drainage Easement	_____ 
Proposed Permanent Drainage Easement	_____ 
Proposed Permanent Utility Easement	_____ 







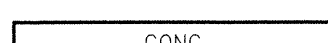

ROADS AND RELATED FEATURES:

Existing Edge of Pavement	_____
Existing Curb	_____
Proposed Slope Stakes Cut	_____ 
Proposed Slope Stakes Fill	_____ 
Proposed Wheel Chair Ramp	_____ 
Curb Cut for Future Wheel Chair Ramp	_____ 
Existing Metal Guardrail	_____ 
Proposed Guardrail	_____ 
Existing Cable Guiderail	_____ 
Proposed Cable Guiderail	_____ 
Equality Symbol	_____ 
Pavement Removal	_____ 

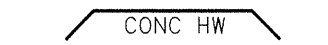

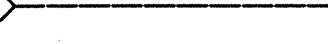
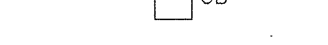





VEGETATION:

Single Tree	_____ 
Single Shrub	_____ 
Hedge	_____ 
Woods Line	_____ 
Orchard	_____ 
Vineyard	_____ 



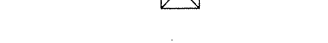

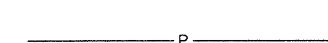
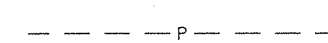



EXISTING STRUCTURES:

MAJOR:	
Bridge, Tunnel or Box Culvert	_____ 
Bridge Wing Wall, Head Wall and End Wall	_____ 
MINOR:	
Head and End Wall	_____ 
Pipe Culvert	_____ 
Footbridge	_____ 
Drainage Box: Catch Basin, DI or JB	_____ 
Paved Ditch Gutter	_____ 
Storm Sewer Manhole	_____ 
Storm Sewer	_____ 

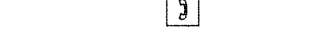
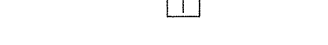
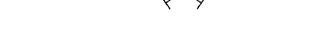



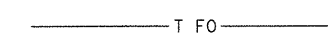
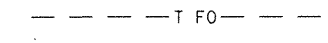

UTILITIES:

POWER:	
Existing Power Pole	_____ 
Proposed Power Pole	_____ 
Existing Joint Use Pole	_____ 
Proposed Joint Use Pole	_____ 
Power Manhole	_____ 
Power Line Tower	_____ 
Power Transformer	_____ 
U/G Power Cable Hand Hole	_____ 
H-Frame Pole	_____ 
Recorded U/G Power Line	_____ 
Designated U/G Power Line (S.U.E.*)	_____ 







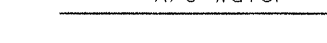

TELEPHONE:

Existing Telephone Pole	_____ 
Proposed Telephone Pole	_____ 
Telephone Manhole	_____ 
Telephone Booth	_____ 
Telephone Pedestal	_____ 
Telephone Cell Tower	_____ 
U/G Telephone Cable Hand Hole	_____ 
Recorded U/G Telephone Cable	_____ 
Designated U/G Telephone Cable (S.U.E.*)	_____ 
Recorded U/G Telephone Conduit	_____ 
Designated U/G Telephone Conduit (S.U.E.*)	_____ 
Recorded U/G Fiber Optics Cable	_____ 
Designated U/G Fiber Optics Cable (S.U.E.*)	_____ 





WATER:

Water Manhole	_____ 
Water Meter	_____ 
Water Valve	_____ 
Water Hydrant	_____ 
Recorded U/G Water Line	_____ 
Designated U/G Water Line (S.U.E.*)	_____ 
Above Ground Water Line	_____ 





TV:

TV Satellite Dish	_____ 
TV Pedestal	_____ 
TV Tower	_____ 
U/G TV Cable Hand Hole	_____ 
Recorded U/G TV Cable	_____ 
Designated U/G TV Cable (S.U.E.*)	_____ 
Recorded U/G Fiber Optic Cable	_____ 
Designated U/G Fiber Optic Cable (S.U.E.*)	_____ 





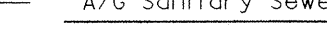





GAS:

Gas Valve	_____ 
Gas Meter	_____ 
Recorded U/G Gas Line	_____ 
Designated U/G Gas Line (S.U.E.*)	_____ 
Above Ground Gas Line	_____ 

SANITARY SEWER:

Sanitary Sewer Manhole	_____ 
Sanitary Sewer Cleanout	_____ 
U/G Sanitary Sewer Line	_____ 
Above Ground Sanitary Sewer	_____ 
Recorded SS Forced Main Line	_____ 
Designated SS Forced Main Line (S.U.E.*)	_____ 

MISCELLANEOUS:

Utility Pole	_____ 
Utility Pole with Base	_____ 
Utility Located Object	_____ 
Utility Traffic Signal Box	_____ 
Utility Unknown U/G Line	_____ 
U/G Tank; Water, Gas, Oil	_____ 
A/G Tank; Water, Gas, Oil	_____ 
U/G Test Hole (S.U.E.*)	_____ 
Abandoned According to Utility Records	_____ 
End of Information	_____ 

REVISIONS

40409 PM RR Roadway\Proj\40409_rds_1.sh.dgn 2/29/2008

SURVEY CONTROL SHEET B-4109

DURHAM COUNTY

**LOCATION: BRIDGE NO. 120 OVER MUD CREEK
AND APPROACHES ON SR 1303 (PICKETT RD.)**



TIP: B-4109

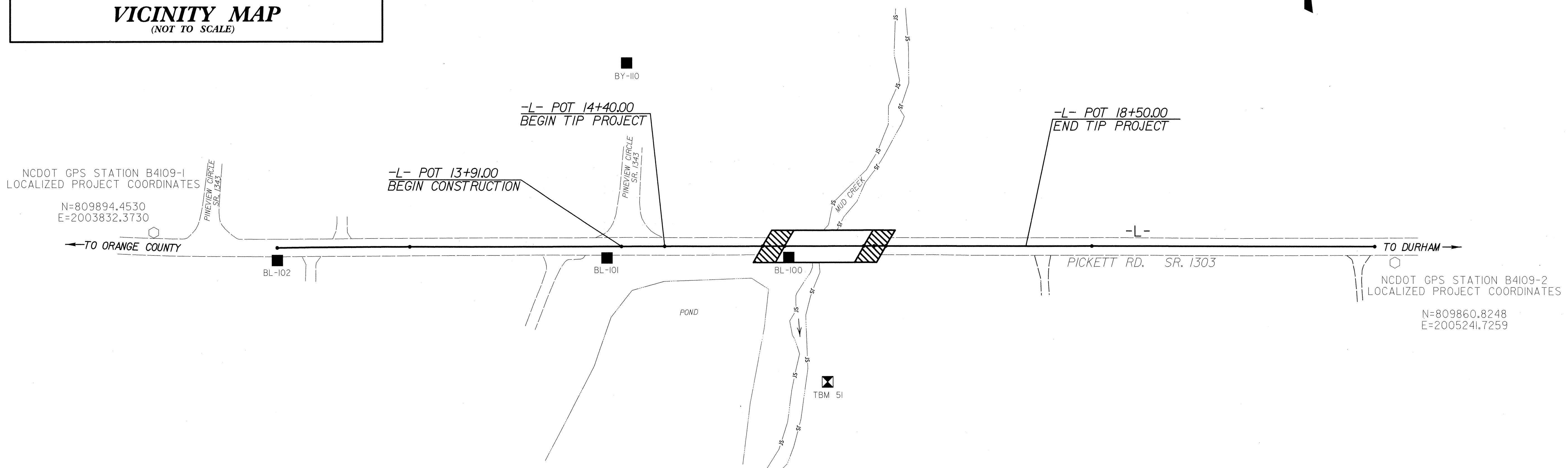
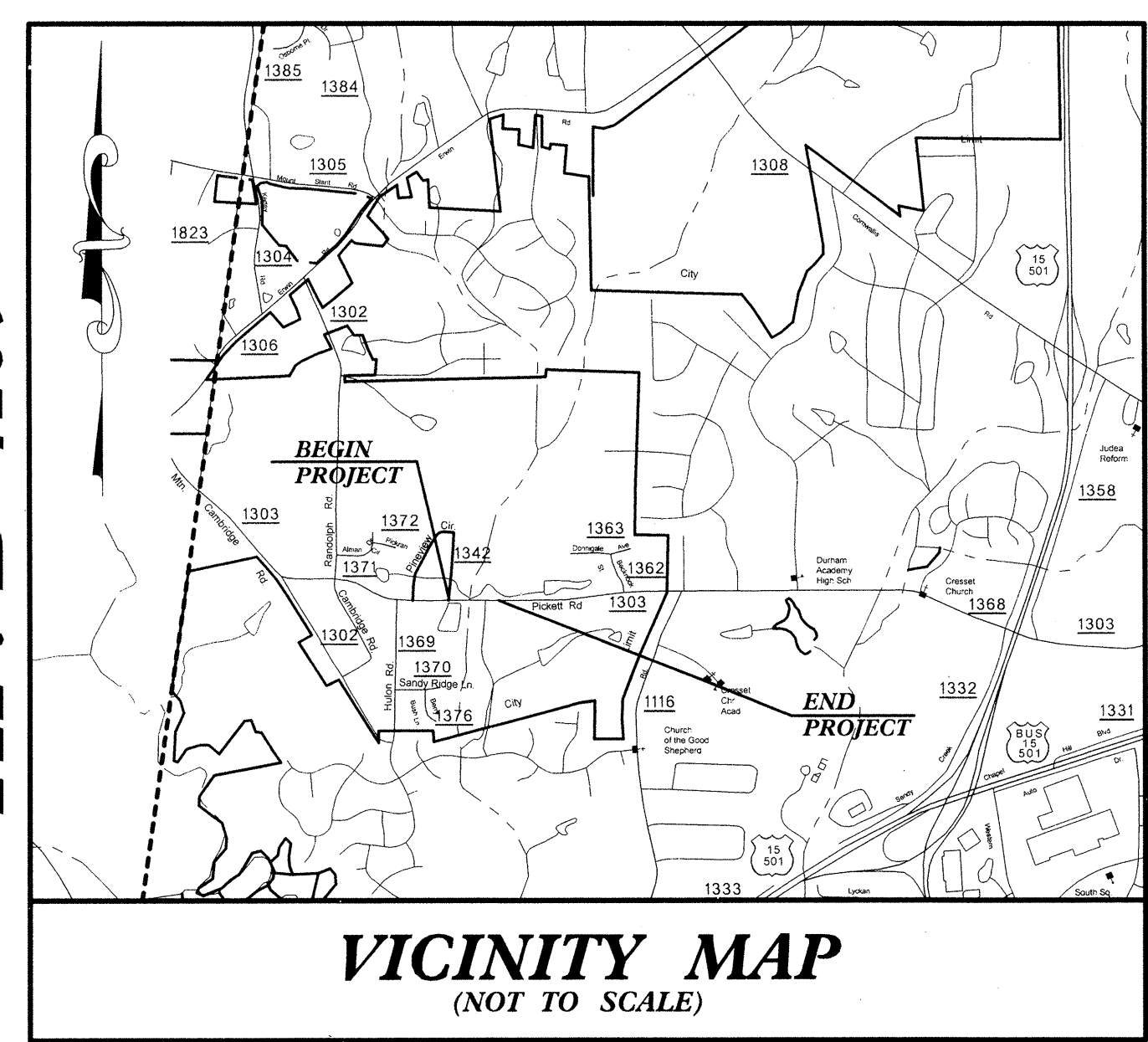

CONTROL DATA

BASELINE POINT	DESC.	NORTH	EAST	ELEVATION	L STATION	OFFSET
102	BL-102	809862.9104	2003972.5916	288.52	10+00.00	14.00 RT
101	BL-101	809866.0396	2004347.0039	269.47	13+74.43	12.78 RT
100	BL-100	809866.6372	2004553.1883	264.16	15+80.61	12.67 RT
2	B4109-2	809860.8248	2005241.7259	270.08	OUTSIDE PROJECT LIMITS	

BY POINT	DESC.	NORTH	EAST	ELEVATION	L STATION	OFFSET
101	BL-101	809866.0396	2004347.0039	269.47	13+74.43	12.78 RT
110	BY-110	810086.7082	2004369.6625	265.35	13+97.60	207.83 LT

BENCHMARK DATA

.....
 BM 51 ELEVATION = 260.20
 N 809726 E 2004597
 L STATION 16+24 152 RIGHT
 R/R SPIKE IN 9 INCH SWEET GUM

DATUM DESCRIPTION

THE LOCALIZED COORDINATE SYSTEM DEVELOPED FOR THIS PROJECT IS BASED ON THE STATE PLANE COORDINATES ESTABLISHED BY NCDOT FOR MONUMENT "B4109-1" WITH NAD 1983/95 STATE PLANE GRID COORDINATES OF NORTHING: 809894.4530(ft) EASTING: 2003832.3730(ft) THE AVERAGE COMBINED GRID FACTOR USED ON THIS PROJECT (GROUND TO GRID) IS: 0.99994375 THE N.C. LAMBERT GRID BEARING AND LOCALIZED HORIZONTAL GROUND DISTANCE FROM "B4109-1" TO -L- STATION 13+91.00 IS S 88°19'06.7 E 531.40'

ALL LINEAR DIMENSIONS ARE LOCALIZED HORIZONTAL DISTANCES
 VERTICAL DATUM USED IS NAVD 88

NOTES:

THE CONTROL DATA FOR THIS PROJECT CAN BE FOUND ELECTRONICALLY BY SELECTING PROJECT CONTROL DATA AT:
[HTTP://WWW.DOH.DOT.STATE.NC.US/PRECONSTRUCT/HIGHWAY/LOCATION/PROJECT/](http://www.doh.dot.state.nc.us/preconstruct/highway/location/project/)
 B4109_ls_control_060907.txt

SITE CALIBRATION INFORMATION HAS NOT BEEN PROVIDED FOR THIS PROJECT. IF FURTHER INFORMATION IS NEEDED, PLEASE CONTACT THE LOCATION AND SURVEYS UNIT.

○ INDICATES GEODETIC CONTROL MONUMENTS USED OR SET FOR HORIZONTAL PROJECT CONTROL BY THE NCDOT LOCATION AND SURVEYS UNIT.

PROJECT CONTROL ESTABLISHED USING GLOBAL POSITIONING SYSTEM.
 NETWORK ESTABLISHED FROM NGS ONLINE POSITIONING SERVICE (OPUS)

NOTE: DRAWING NOT TO SCALE

6/2/99
 R:\2008\Projects\B4109-1s.lc-060907.dgn
 10:56:37 AM

PAVEMENT SCHEDULE

C1	PROPOSED APPROX. 3" ASPHALT CONCRETE SURFACE COURSE, TYPE S9.5B, AT AN AVERAGE RATE OF 168 LBS. PER SQ. YARD IN EACH OF TWO LAYERS.
C2	PROPOSED VARIABLE DEPTH ASPHALT CONCRETE SURFACE COURSE, TYPE S9.5B, AT AN AVERAGE RATE OF 112 LBS. PER SQ. YARD, PER 1" DEPTH, TO BE PLACED IN LAYERS NOT LESS THAN 1 1/2" OR GREATER THAN 2" IN DEPTH.
D1	PROPOSED APPROX. 2 1/2" ASPHALT CONCRETE INTERMEDIATE COURSE, TYPE I19.0B, AT AN AVERAGE RATE OF 285 LBS. PER SQ. YARD
D2	PROPOSED VARIABLE DEPTH ASPHALT CONCRETE INTERMEDIATE COURSE, TYPE I19.0B, AT AN AVERAGE RATE OF 114 LBS. PER SQ. YARD, PER 1" DEPTH, TO BE PLACED IN LAYERS NOT LESS THAN 2 1/2" OR GREATER THAN 4" IN DEPTH.
E1	PROPOSED APPROXIMATE 4" ASPHALT CONCRETE BASE COURSE, TYPE B25.0B, AT AN AVERAGE RATE OF 456 LBS. PER SQ. YARD.
E2	PROPOSED VARIABLE DEPTH ASPHALT CONCRETE BASE COURSE, TYPE B25.0B, AT AN AVERAGE RATE OF 114 LBS. PER SQ. YARD, PER 1" DEPTH, TO BE PLACED IN LAYERS NOT LESS THAN 3" OR GREATER THAN 5 1/2" IN DEPTH.
T	EARTH MATERIAL
U	EXISTING PAVEMENT
W	WEDGING DETAIL

NOTE: ALL PAVEMENT EDGE SLOPES ARE 1:1 UNLESS OTHERWISE SHOWN.

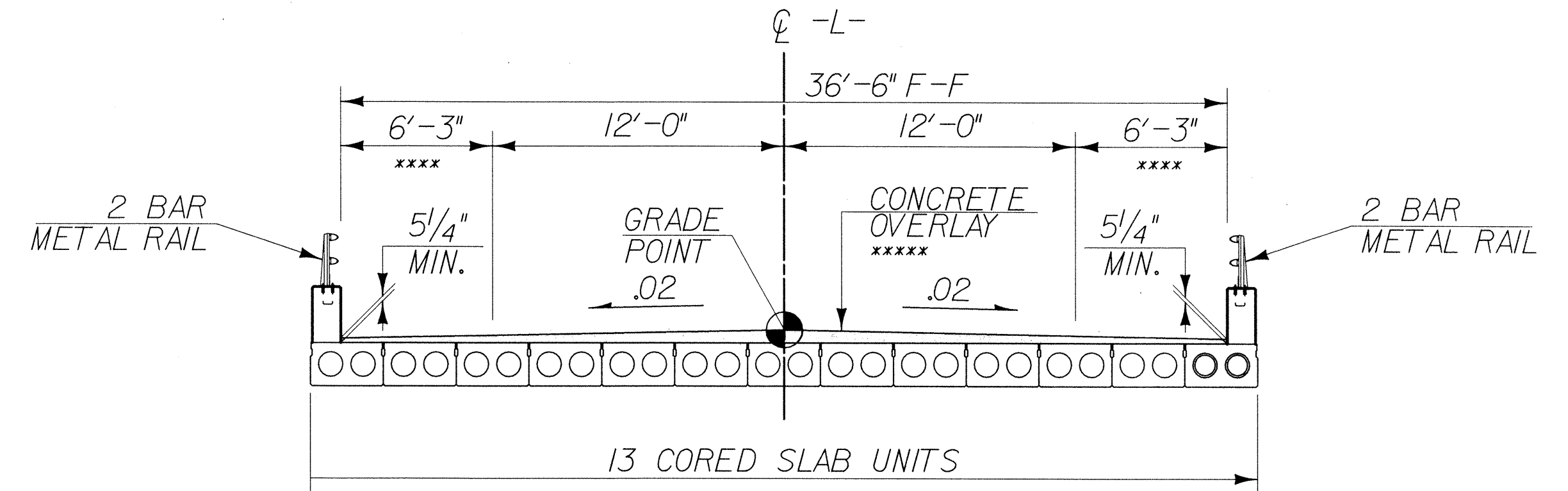
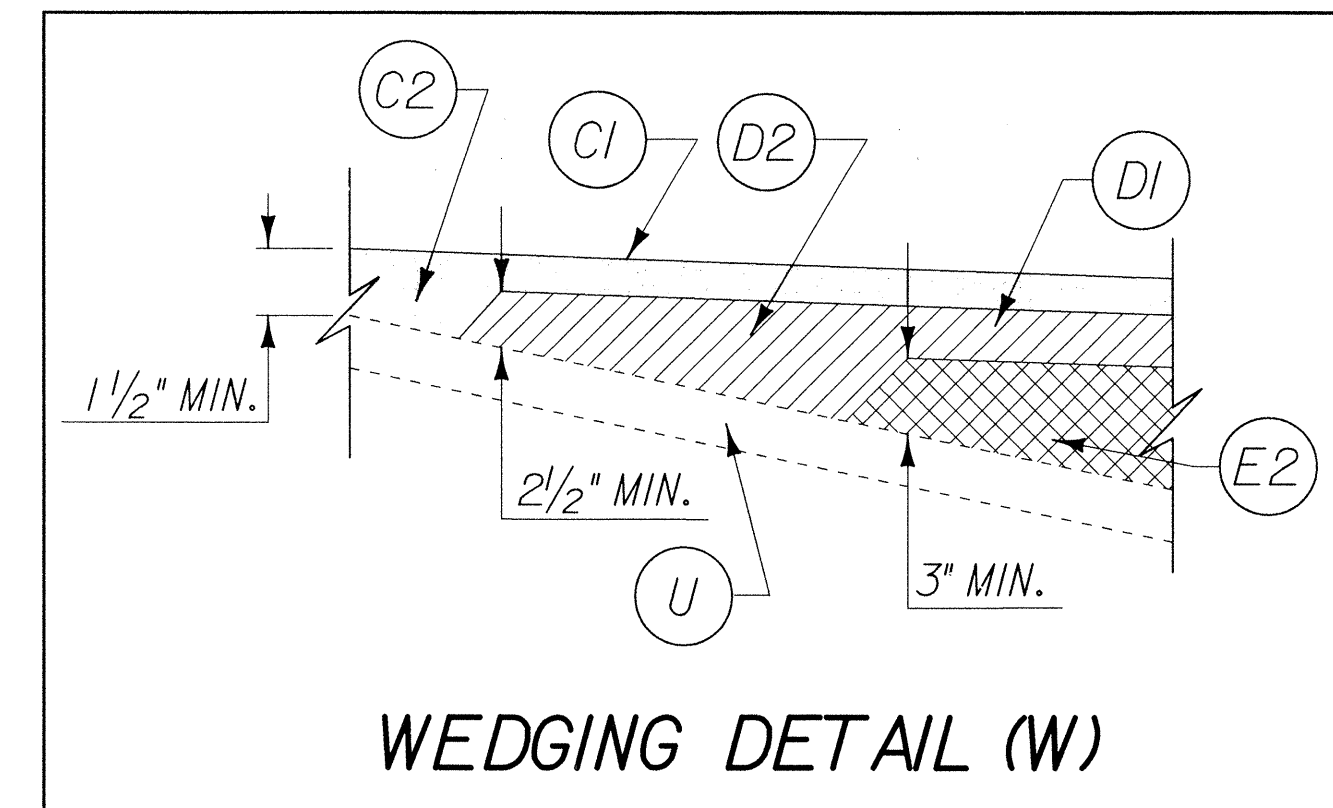

TYPICAL SECTION No. 2

USE TYPICAL SECTION No. 2 AS FOLLOWS:

FROM -L- STA. 15+76.00 (BEGIN BRIDGE) TO -L- STA. 16+66.00 (END BRIDGE)

**** OFFSET INCREASED TO 6'-3" TO ACCOUNT FOR HYDRAULIC SPREAD
***** STRUCTURE PAY ITEM

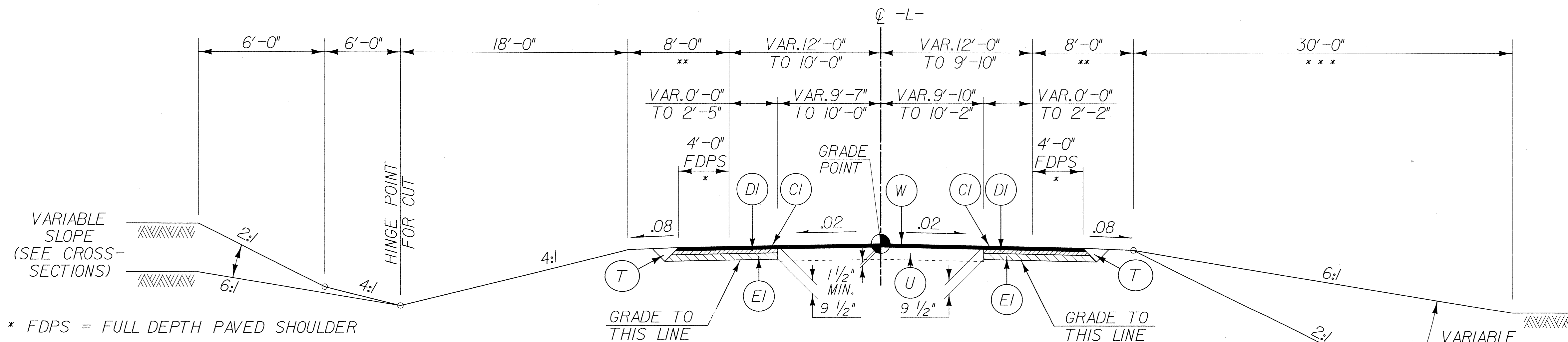

TYPICAL SECTION No. 1

USE TYPICAL SECTION No. 1 AS FOLLOWS:

TRANSITION FROM EXISTING TO T.S. NO. 1 FROM -L- STA. 14+40.00 TO -L- STA. 15+05.00
FROM -L- STA. 15+05.00 TO -L- STA. 15+26.00
FROM -L- STA. 17+16.00 TO -L- STA. 17+85.00
TRANSITION FROM T.S. NO. 1 TO EXISTING FROM -L- STA. 17+85.00 TO -L- STA. 18+50.00

* FDPS = FULL DEPTH PAVED SHOULDER

** ADD 3'-0" FOR GUARDRAIL

*** WHEN THESE DISTANCES INDICATE SLOPES OUTSIDE THE LIMITS OF 6:1 TO 2:1 THE DISTANCE BECOMES VARIABLE AND THE MAXIMUM OR MINIMUM SLOPE MAINTAINED.

NOTE: 4'-0" FDPS WILL EXTEND A MINIMUM OF 100' FROM EACH SIDE OF THE PROP. APPROACH TO THE NEW BRIDGE TO ACCOMMODATE BICYCLE ROUTE - SEE PLANS.

MULKEY
ENGINEERS & CONSULTANTS
PO BOX 33127
RALEIGH, N.C. 27636
(919) 851-1912
(919) 851-1918 (FAX)
WWW.MULKEYINC.COM

PROJECT REFERENCE NO. B-4109	SHEET NO. 2
ROADWAY DESIGN RW SHEET NO.	PAVEMENT DESIGN ENGINEER

REVISIONS

0:59:32 AMR:\Roadway Proj\B4109_rdy_typ.dwg

3/3/2008

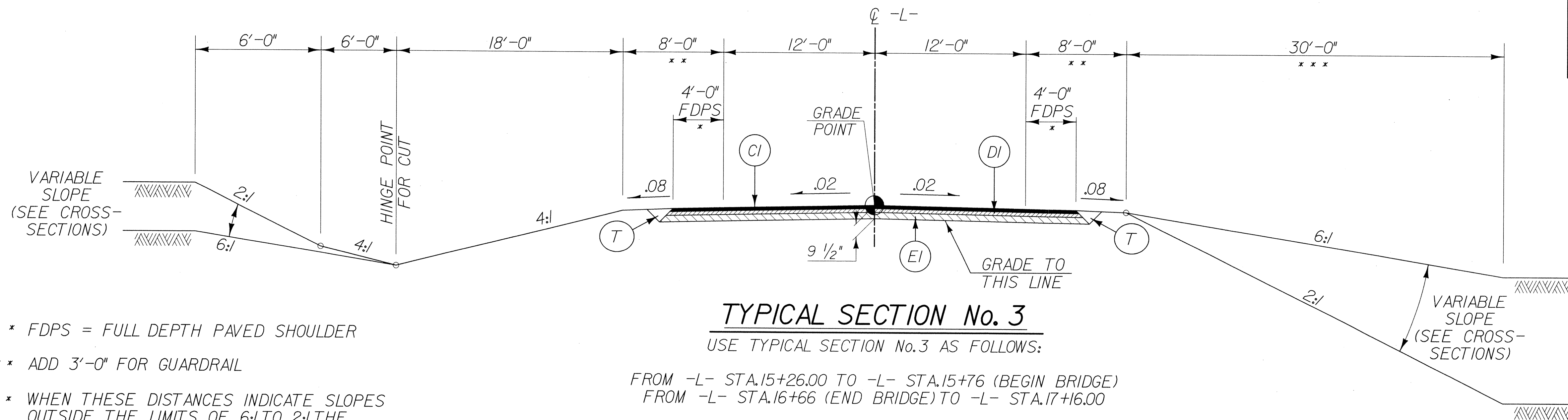

TYPICAL SECTION No. 3

USE TYPICAL SECTION No.3 AS FOLLOWS:

FROM -L- STA.15+26.00 TO -L- STA.15+76 (BEGIN BRIDGE)
FROM -L- STA.16+66 (END BRIDGE) TO -L- STA.17+16.00

- * FDPS = FULL DEPTH PAVED SHOULDER
- ** ADD 3'-0" FOR GUARDRAIL
- *** WHEN THESE DISTANCES INDICATE SLOPES OUTSIDE THE LIMITS OF 6:1 TO 2:1 THE DISTANCE BECOMES VARIABLE AND THE MAXIMUM OR MINIMUM SLOPE MAINTAINED.

C1	3" S9.5B
C2	VAR. DEPTH S9.5B
D1	2 1/2" 119.0B
D2	VAR. DEPTH 119.0B
E1	4" B25.0B
E2	VAR. DEPTH B25.0B
T	EARTH MATERIAL
U	EXIST. PAVEMENT
W	WEDGING

NOTE:

1. SEE SHEET 2 FOR DETAILED DESCRIPTION OF PAVEMENT SCHEDULE

2. ALL PAVEMENT EDGES ARE 1:1 UNLESS OTHERWISE NOTED

REVISIONS

STATE OF NORTH CAROLINA
DEPT. OF TRANSPORTATION
DIVISION OF HIGHWAYS
RALEIGH, N.C.

ENGLISH DETAIL DRAWING FOR
ANCHORAGE FOR FRAMES
BRICK/CONCRETE/PRECAST CONCRETE

SHEET 1 OF 1
840D25

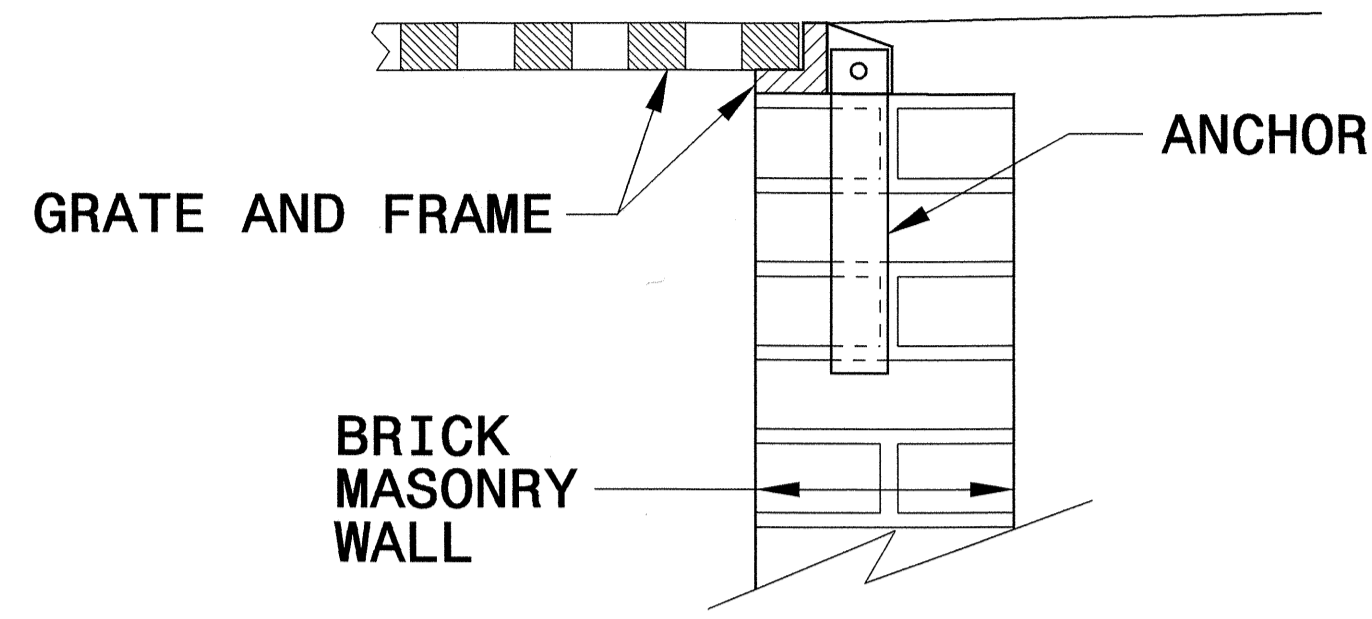

BRICK MASONRY CONSTRUCTION

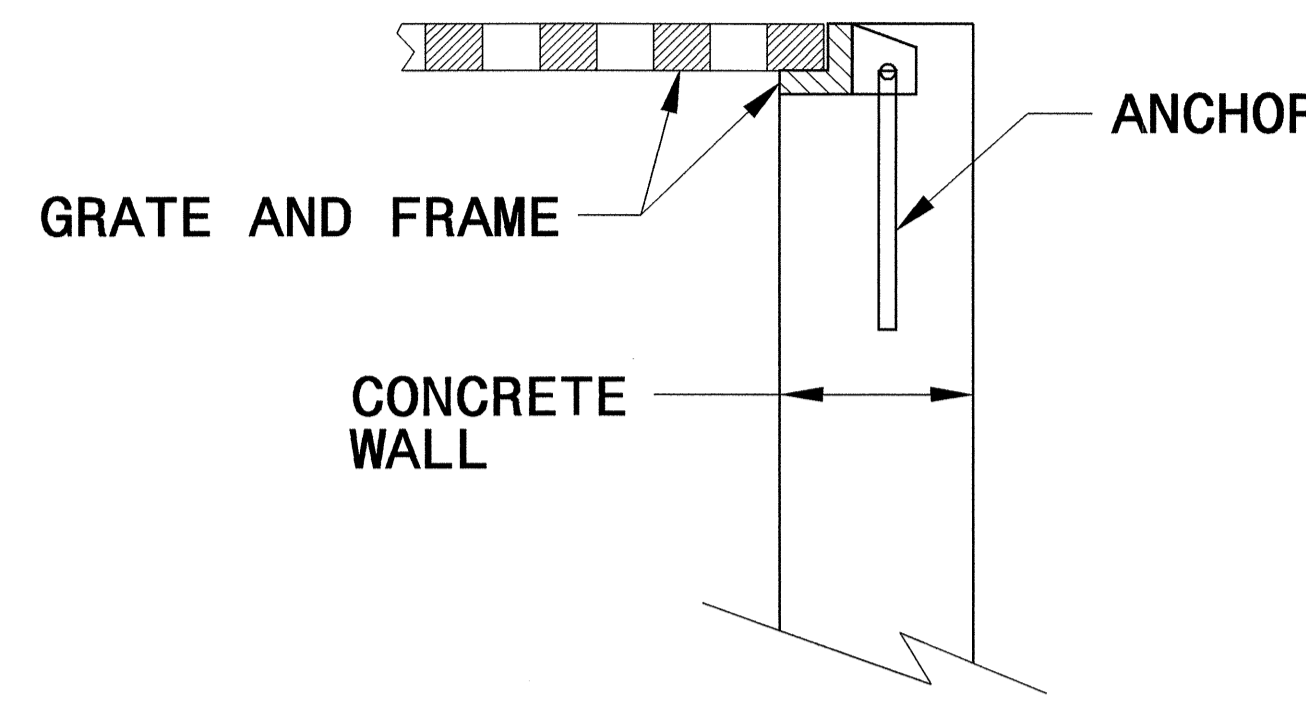

CONCRETE CONSTRUCTION

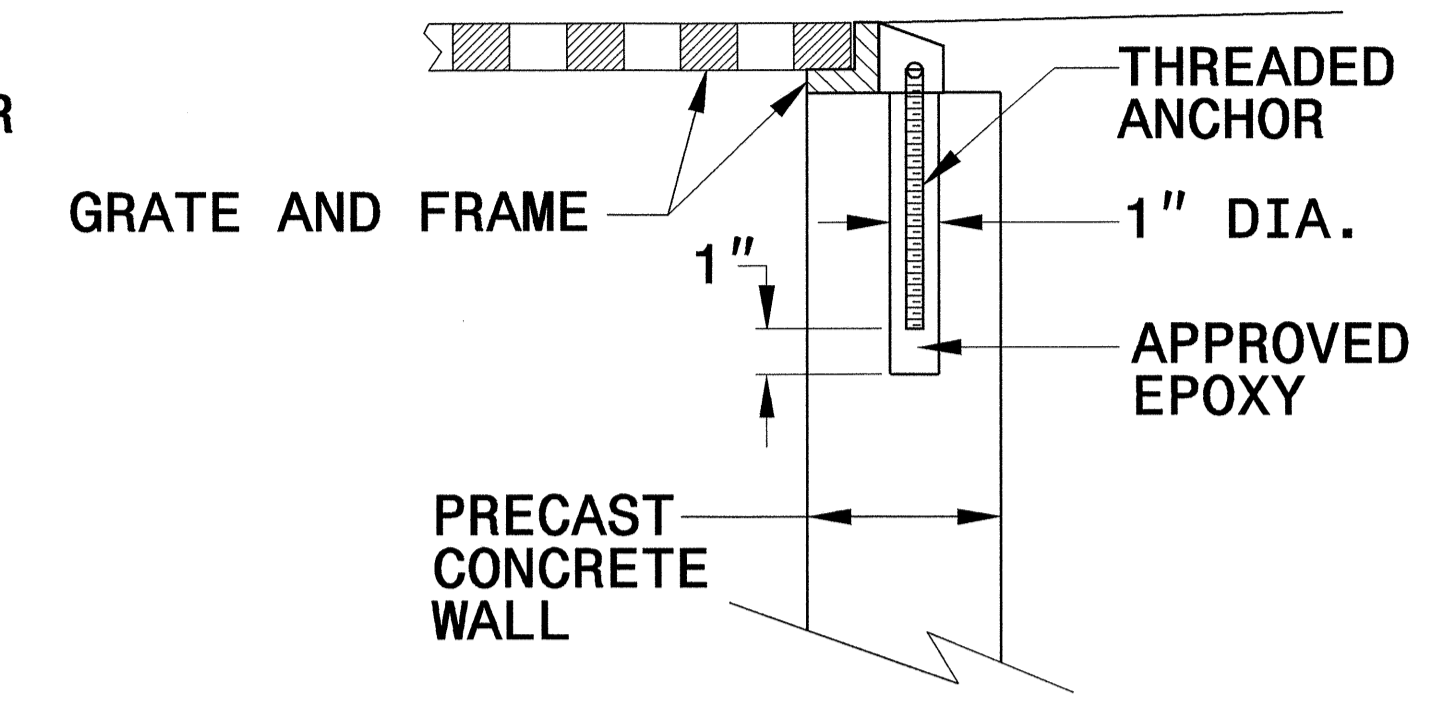

PRECAST CONCRETE CONSTRUCTION

DETAIL SHOWING ANCHORAGE OF FRAME FOR GRATED DROP INLET

NOTE:
CONSTRUCT GRATED DROP INLET TO COINCIDE WITH NORMAL OR SUPERELEVATED SHOULDER OR PAVEMENT SLOPE.

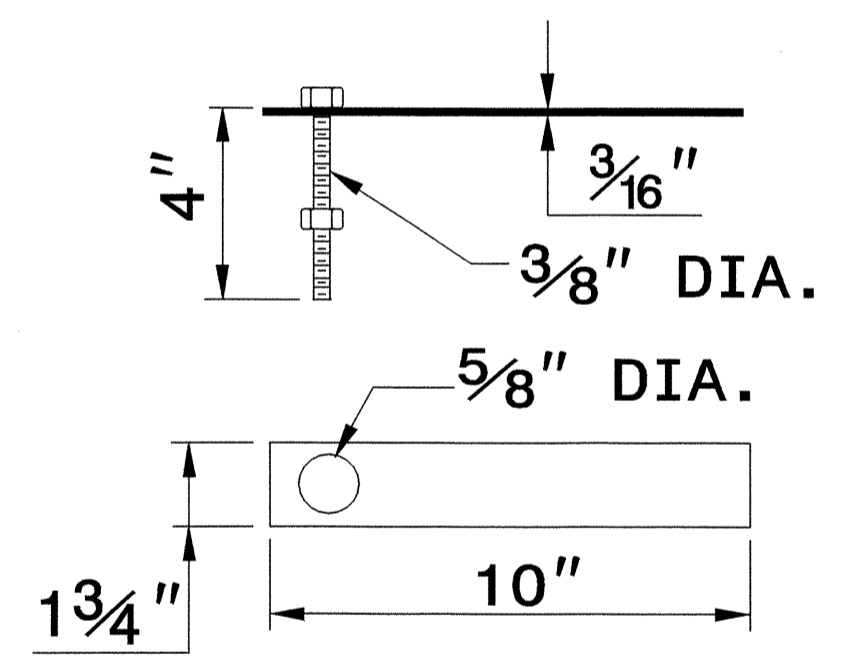

MASONRY ANCHOR
3/8" DIA. BOLT WITH PLATE

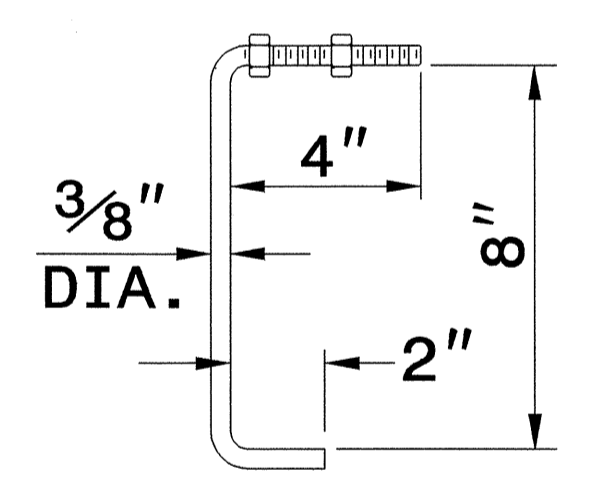

CONCRETE ANCHOR
3/8" DIA. BENT BAR

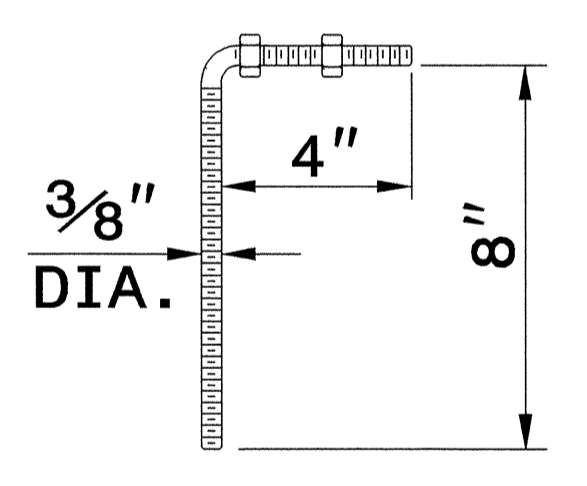

PRECAST CONCRETE ANCHOR
3/8" DIA. BENT BAR

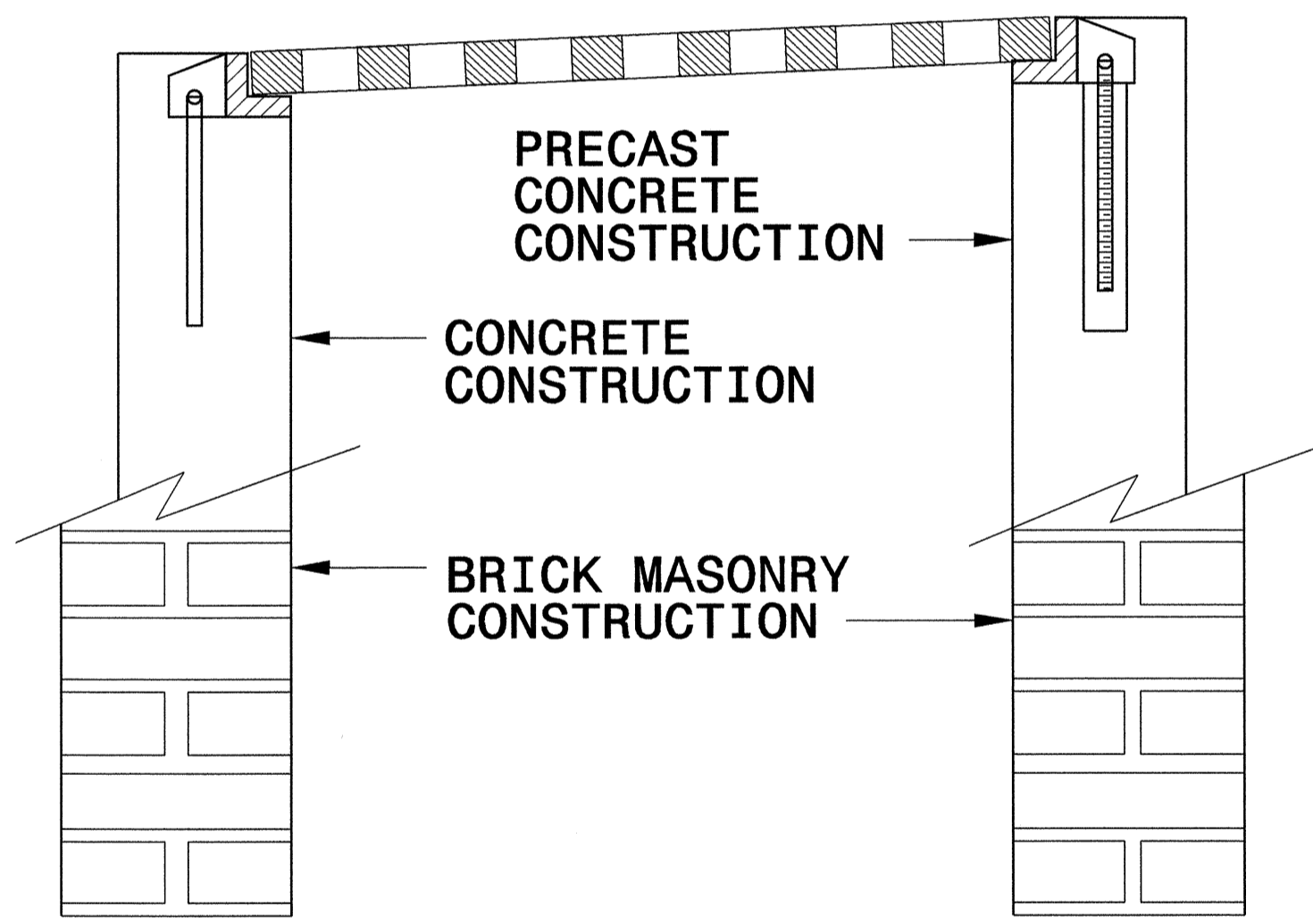

FRAME AND GRATE INSTALLATION FOR NORMAL CROWN AND SUPERELEVATED SECTIONS

STATE OF NORTH CAROLINA
DEPT. OF TRANSPORTATION
DIVISION OF HIGHWAYS
RALEIGH, N.C.

ENGLISH DETAIL DRAWING FOR
ANCHORAGE FOR FRAMES
BRICK/CONCRETE/PRECAST CONCRETE

SHEET 1 OF 1
840D25

\$\$\$SYTIME\$\$\$
\$\$\$SUBSECTION\$\$\$
\$\$\$USERNAME\$\$\$

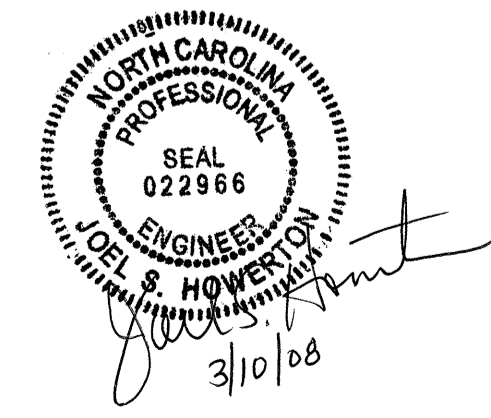

PROJECT SERVICES UNIT
STANDARDS AND SPECIAL DESIGN
Office 919-250-4128 FAX 919-250-4119

SEE PLATE FOR TITLE

ORIGINAL BY: 2006 STD 840.25 DATE: 07/18/06
MODIFIED BY: E.E. WARD DATE: 9/25/06
CHECKED BY: DATE:
FILE SPEC.:

STATE OF NORTH CAROLINA
DIVISION OF HIGHWAYS
ROADWAY SUMMARY OF QUANTITIES FOR CONTRACT - C201834

Summary of Quantities

ItemNumber	Sec #	Quantity	Unit	Description
000100000-N	800	Lump Sum		MOBILIZATION
000400000-N	801	Lump Sum		CONSTRUCTION SURVEYING
002900000-N	SP	Lump Sum		REINFORCED BRIDGE APPROACH FILL, STATION ***** (16+21 -L-)
003600000-E	225	250	CY	UNDERCUT EXCAVATION
004300000-N	226	Lump Sum		GRADING
005000000-E	226	1	ACR	SUPPLEMENTARY CLEARING & GRUBBING
019500000-E	265	250	CY	SELECT GRANULAR MATERIAL
019600000-E	270	250	SY	FABRIC FOR SOIL STABILIZATION
031800000-E	300	30	TON	FOUNDATION CONDITIONING MATERIAL, MINOR STRS
070800000-E	310	52	LF	15" BIT COAT CS PIPE CULVERTS, TYPE B 0.064" THICK
080400000-E	310	1	EA	*** BIT COAT CS PIPE ELBOWS, TYPE B ***** THICK (15", 0.064")
122000000-E	545	30	TON	INCIDENTAL STONE BASE
148900000-E	610	130	TON	ASPHALT CONC BASE COURSE, TYPE B25.0B
149800000-E	610	75	TON	ASPHALT CONC INTERMEDIATE COURSE, TYPE I19.0B
151900000-E	610	215	TON	ASPHALT CONC SURFACE COURSE, TYPE S9.5B
156000000-E	620	25	TON	ASPHALT BINDER FOR PLANT MIX, GRADE PG 64-22
169300000-E	654	30	TON	ASPHALT PLANT MIX, PAVEMENT REPAIR
200000000-N	806	8	EA	RIGHT OF WAY MARKERS
228600000-N	840	6	EA	MASONRY DRAINAGE STRUCTURES
235420000-N	840	2	EA	FRAME WITH GRATE, STD 840.24
235500000-N	840	3	EA	FRAME WITH GRATE, STD 840.29
239600000-N	840	1	EA	FRAME WITH COVER, STD 840.54
255600000-E	846	145	LF	SHOULDER BERM GUTTER
303000000-E	862	250	LF	STEEL BM GUARDRAIL
315000000-N	862	5	EA	ADDITIONAL GUARDRAIL POSTS
321500000-N	862	4	EA	GUARDRAIL ANCHOR UNITS, TYPE III
327000000-N	SP	4	EA	GUARDRAIL ANCHOR UNITS, TYPE 350
362800000-E	876	190	TON	RIP RAP, CLASS I
364900000-E	876	2	TON	RIP RAP, CLASS B
365600000-E	876	630	SY	FILTER FABRIC FOR DRAINAGE
440000000-E	1110	415	SF	WORK ZONE SIGNS (STATIONARY)
440500000-E	1110	112	SF	WORK ZONE SIGNS (PORTABLE)
441000000-E	1110	94	SF	WORK ZONE SIGNS (BARRICADE MOUNTED)
443000000-N	1130	15	EA	DRUMS
443500000-N	1135	15	EA	CONES
444500000-E	1145	96	LF	BARRICADES (TYPE III)
445000000-N	1150	80	HR	FLAGGER
468500000-E	1205	1,050	LF	THERMOPLASTIC PAVEMENT MARKING LINES (4", 90 MILS)
468600000-E	1205	1,050	LF	THERMOPLASTIC PAVEMENT MARKING LINES (4", 120 MILS)
471000000-E	1205	80	LF	THERMOPLASTIC PAVEMENT MARKING LINES (24", 120 MILS)
481000000-E	1205	4,200	LF	PAINT PAVEMENT MARKING LINES (4")
483500000-E	1205	160	LF	PAINT PAVEMENT MARKING LINES (24")
490000000-N	1251	10	EA	PERMANENT RAISED PAVEMENT MARKERS
532660000-E	1510	408	LF	16" WATER LINE
555860000-E	1515	1	EA	16" VALVE
566600000-E	1515	1	EA	FIRE HYDRANT
569140000-E	1520	704	LF	10" SANITARY GRAVITY SEWER
577500000-E	1525	3	EA	4" DIA UTILITY MANHOLE
587190000-E	1550	80	LF	TRENCHLESS INSTALLATION OF 16" IN SOIL

ItemNumber	Sec #	Quantity	Unit	Description
5871910000-E	1550	80	LF	TRENCHLESS INSTALLATION OF 16" NOT IN SOIL
5882000000-N	SP	1	EA	GENERIC UTILITY ITEM 20" STEEL ENCASMENT PIPE, 0.500" THICK & CONC COLLARS
5882000000-N	SP	1	EA	GENERIC UTILITY ITEM 4' DIA PC CONC SEWER MANHOLE WITH A FLAT TOP, 0-6' DEPTH
5882000000-N	SP	1	EA	GENERIC UTILITY ITEM 4' DIA PC CONC SEWER MANHOLE WITH FLAT TOP & VENT, 0-6' DEPTH
5888000000-E	SP	25	LF	GENERIC UTILITY ITEM UTILITY MANHOLE WALL, 4' DIA
6000000000-E	1605	960	LF	TEMPORARY SILT FENCE
6006000000-E	1610	75	TON	STONE FOR EROSION CONTROL, CLASS A
6009000000-E	1610	75	TON	STONE FOR EROSION CONTROL, CLASS B
6012000000-E	1610	170	TON	SEDIMENT CONTROL STONE
6015000000-E	1615	0.5	ACR	TEMPORARY MULCHING
6018000000-E	1620	50	LB	SEED FOR TEMPORARY SEEDING
6021000000-E	1620	0.25	TON	FERTILIZER FOR TEMPORARY SEEDING
6029000000-E	SP	200	LF	SAFETY FENCE
6030000000-E	1630	130	CY	SILT EXCAVATION
6036000000-E	1631	240	SY	MATTING FOR EROSION CONTROL
6042000000-E	1632	50	LF	1/4" HARDWARE CLOTH
6070000000-N	SP	6	EA	SPECIAL STILLING BASINS
6071030000-E	SP	30	LF	COIR FIBER BAFFLES
6084000000-E	1660	0.5	ACR	SEEDING & MULCHING
6087000000-E	1660	0.5	ACR	MOWING
6090000000-E	1661	50	LB	SEED FOR REPAIR SEEDING
6093000000-E	1661	0.25	TON	FERTILIZER FOR REPAIR SEEDING
6096000000-E	1662	50	LB	SEED FOR SUPPLEMENTAL SEEDING
6108000000-E	1665	0.5	TON	FERTILIZER TOPDRESSING

ItemNumber	Sec #	Quantity	Unit	Description
6114000000-N	SP	2	HR	SPECIALIZED HAND MOWING
6117000000-N	SP	12	EA	RESPONSE FOR EROSION CONTROL
7060000000-E	1705	540	LF	SIGNAL CABLE
7120000000-E	1705	9	EA	VEHICLE SIGNAL HEAD (12", 3 SECTION)
7252000000-E	1710	2,700	LF	MESSANGER CABLE (1/4")
7264000000-E	1710	340	LF	MESSANGER CABLE (3/8")
7288000000-E	1715	10	LF	PAVED TRENCHING (***** (1, 2))
7300000000-E	1715	380	LF	UNPAVED TRENCHING (***** (1, 2))
7324000000-N	1716	6	EA	JUNCTION BOX (STANDARD SIZE)
7360000000-N	1720	3	EA	WOOD POLE
7372000000-N	1721	17	EA	GUY ASSEMBLY
7408000000-E	1722	1	EA	1" RISER WITH WEATHERHEAD
7420000000-E	1722	4	EA	2" RISER WITH WEATHERHEAD
7432000000-E	1722	1	EA	2" RISER WITH HEAT SHRINK TUBING
7444000000-E	1725	400	LF	INDUCTIVE LOOP SAWCUT
7456000000-E	1726	1,110	LF	LEAD-IN CABLE (***** (14-2))
7516000000-E	1730	2,920	LF	COMMUNICATIONS CABLE (**FIBER) (12)
7552000000-N	1731	1	EA	INTERCONNECT CENTER
7564000000-N	1732	1	EA	FIBER-OPTIC TRANSCEIVER, DROP & REPEAT
7568000000-N	SP	1	EA	FURNISH FIBER-OPTIC RESTORATION KIT
7574000000-N	SP	1	EA	FURNISH FIBER-OPTIC TRANSCEIVER
7684000000-N	1750	1	EA	SIGNAL CABINET FOUNDATION
7720000000-N	1751	1	EA	CONTROLLER WITH CABINET (TYPE 170E, BASE MOUNTED)
7744000000-N	1751	3	EA	DETECTOR CARD (TYPE 170)

ItemNumber	Sec #	Quantity	Unit	Description
7901010000-N	1753	1	EA	CABINET BASE ADAPTER
***** BEGIN SCHEDULE AA *****				
***** (4 ALTERNATES) *****				
0366000000-E	310	216	LF	15" RC PIPE CULVERTS, CLASS III
AA1				
*** OR ***				
0366000000-E	310	200	LF	15" RC PIPE CULVERTS, CLASS III
AA2				
0582000000-E	310	16	LF	15" CS PIPE CULVERTS, 0.064" THICK
AA2				
*** OR ***				
0366000000-E	310	200	LF	15" RC PIPE CULVERTS, CLASS III
AA3				
0536000000-E	SP	16	LF	**** HDPE PIPE CULVERTS (15")
AA3				
*** OR ***				
0366000000-E	310	200	LF	15" RC PIPE CULVERTS, CLASS III
AA4				
0540000000-E	SP	16	LF	**** ALUMINIZED CORRUGATED STEEL PIPE CULVERTS, **** THICK (15", 0.064")
AA4				
***** END SCHEDULE AA *****				

COMPUTED BY: W.A. DATE: 12 / 07
 CHECKED BY: J.B. DATE: 12 / 07



PROJECT REFERENCE NO. B-4109 SHEET NO. 3-B
 RW SHEET NO.

SUMMARY OF EARTHWORK IN CUBIC YARDS

SURVEY LINE	STATION	STATION	UNCLASSIFIED EXCAVATION	UNDERCUT	EMBANKMENT + %	BORROW	WASTE
-L-	13+75.00	15+76	40		113	73	0
BRIDGE							
SUBTOTAL			40		113	73	0
BRIDGE							
-L-	16+66	18+50	30		54	24	0
SUBTOTAL			30		54	24	0
PROJECT TOTALS			70		167	97	0
EST. 5% FOR REPLACING TOP SOIL ON BORROW						5	
GRAND TOTAL			70			102	
SAY			75			110	

UNDERCUT EXCAVATION (CONTINGENCY) = 250 CY

NOTE: Earthwork quantities are calculated by the Roadway Design Unit. These earthwork quantities are based in part on subsurface data provided by the Geotechnical Engineering Unit.

NOTE: APPROXIMATE QUANTITIES ONLY. UNCLASSIFIED EXCAVATION, BORROW EXCAVATION, FINE GRADING, CLEARING AND GRUBBING, AND REMOVAL OF EXISTING PAVEMENT WILL BE PAID FOR AT THE CONTRACT LUMP SUM PRICE FOR "GRADING". (SEE PROJECT SPECIAL PROVISIONS.)

SUMMARY OF PAVEMENT REMOVAL IN SQUARE YARDS

LOCATION	ASPHALT REMOVAL	ASPHALT BREAK-UP	CONCRETE REMOVAL	CONCRETE BREAK-UP
-L- 15+26.00 - 15+94.96	151			
-L- 16+43.62 - 17+16.00	156			
TOTAL	307			
SAY	320			

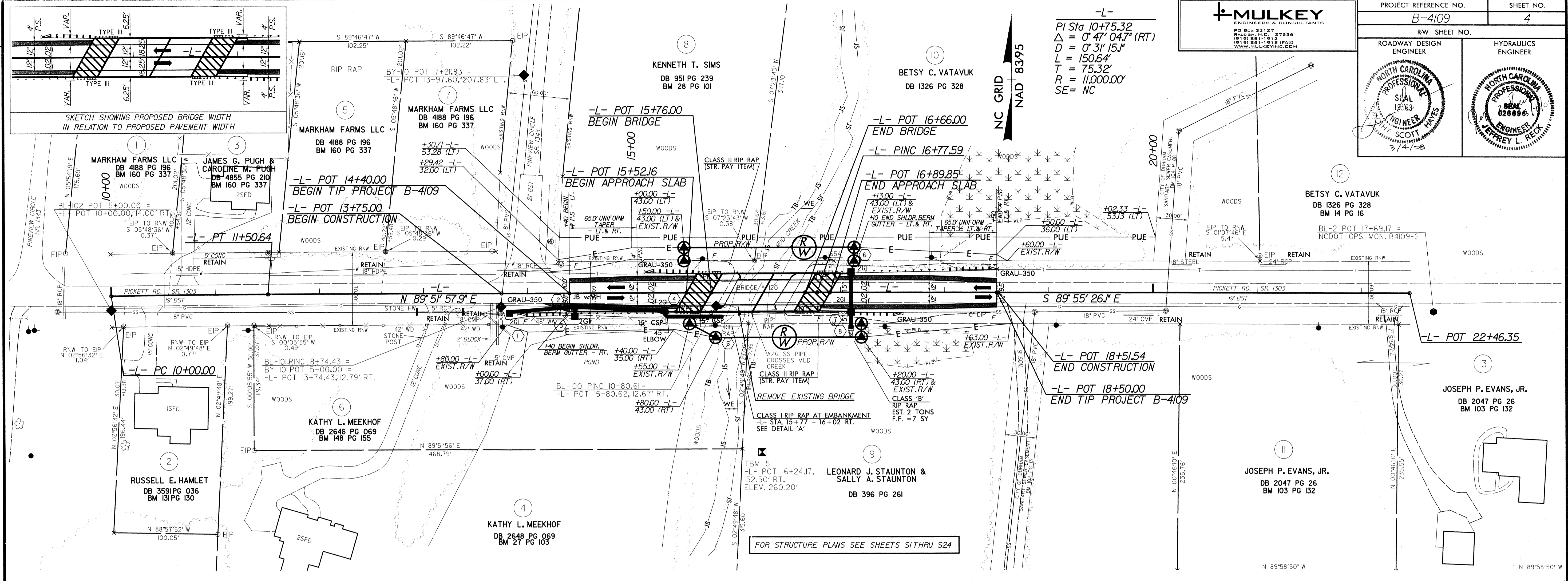

REVISIONS

DETAIL 'A'
RIP RAP AT EMBANKMENT
(Not to Scale)

Type of Liner = Class I Rip-Rap

LINE	STA. TO STA.	RIP RAP (TONS)	FILTER FABRIC (YD ²)
-L-	15+77 TO 16+02 RT.	185	200

BM *51, ELEV. = 260.20'
-L- STA. 16+24.17, 152.50' RT.
RR SPIKE IN 9' SWEET GUM

PI = 15+35.00
EL = 265.49'
VC = 90'
K = 65
D.S. = 40 mph

BRIDGE HYDRAULIC DATA

DESIGN DISCHARGE	= 3140 CFS
DESIGN FREQUENCY	= 25 YRS
DESIGN HW ELEVATION	= 263.8 FT
BASE DISCHARGE	= 4398 CFS
BASE FREQUENCY	= 100 YRS
BASE HW ELEVATION	= 264.8 FT
OVERTOPPING DISCHARGE	= 2498 CFS
OVERTOPPING FREQUENCY	= 10 YRS
OVERTOPPING ELEVATION	= 263.1 FT

DATE OF SURVEY = 4-14-06
W.S. ELEVATION AT DATE OF SURVEY = 252.2 FT

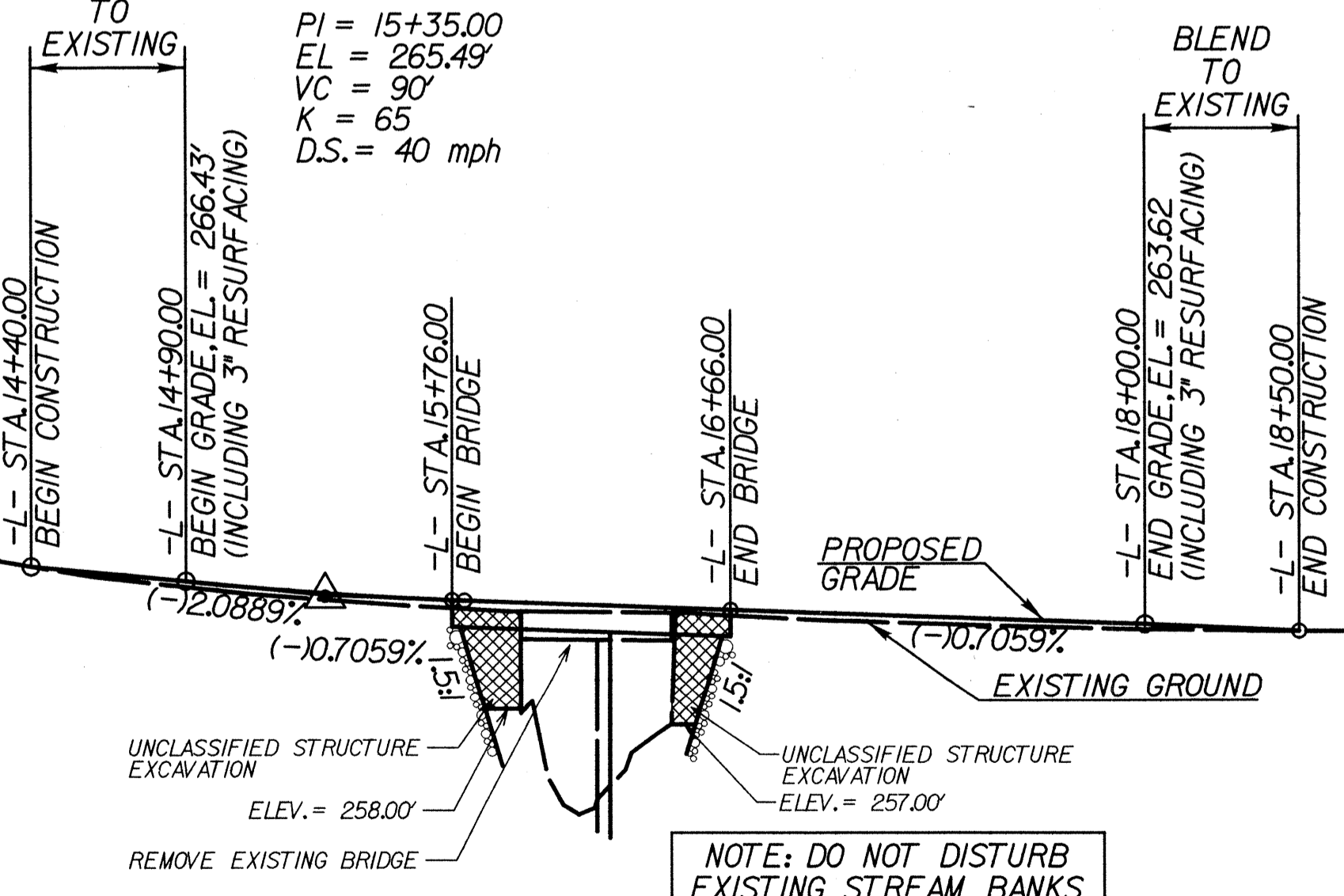

310
300
290
280
270
260
250
240
230

310
300
290
280
270
260
250
240
230

10+00 11+00 12+00 13+00 14+00 15+00 16+00 17+00 18+00 19+00 20+00 21+00 22+00