

FINAL PAV'T MARKING SCHEDULE

SYMBOL	DESCRIPTION	QUANTITY BREAKDOWN	PAY ITEM	TOTAL QUANTITY
PAVEMENT MARKING LINES				
THERMOPLASTIC (4", 90 mils)				
TA	WHITE EDGELINE	15,800 ft		
TB	YELLOW EDGELINE	400 ft		
			TOTAL	16,200 ft
THERMOPLASTIC (4", 120 mils)				
TD	2 ft. WHITE MINISKIP	193 ft		
TE	WHITE SOLID LANE LINE	1,731 ft		
TF	10 ft YELLOW SKIP	375 ft		
TH	YELLOW 40' SOLID & SKIP (NO PASS)	1,500 ft		
TI	YELLOW DOUBLE CENTER LINE	15,302 ft		
			TOTAL	19,101 ft
THERMOPLASTIC (8", 90 mils)				
TT	YELLOW DIAGONAL	235 ft		
			TOTAL	235 ft
THERMOPLASTIC (24", 120 mils)				
T2	WHITE STOPBAR	189 ft		
			TOTAL	189
PAVEMENT MARKING SYMBOLS				
THERMOPLASTIC THICK SYMBOL (90 mils)				
UA	LEFT TURN ARROW	15 ea		
UB	RIGHT TURN ARROW	8 ea		
UC	STRAIGHT ARROW	5 ea		
UE	STRAIGHT / RIGHT ARROW	3 ea		
			TOTAL	31 ea
PAVEMENT MARKERS				
SNOWPLOWABLE RAISED				
ME	CRYSTAL AND RED	112 ea		
MF	YELLOW AND YELLOW	210 ea		
			TOTAL	322 ea

SEE ROADWAY STANDARD DRAWING NUMBERS 1205.01, 1205.02, 1205.04, 1205.05, 1205.06, 1205.08, 1205.09, 1250.01 AND 1253.01

APPROVED: <i>20 Perry</i> DATE: <i>3/7/08</i>	<h2>FINAL PAVEMENT MARKING PLAN</h2>	
	SCALE: NONE	REVISIONS
	DATE: 01-28	
	DWG. BY: BKS	
	DESIGN BY:	
REVIEWED BY:		CADD FILE

\$\$\$\$\$SYTIME\$\$\$\$\$
\$\$\$\$\$JDONS\$\$\$\$\$
\$\$\$\$\$SERNAME\$\$\$\$\$

BEGIN PROJECT
 -L- STA. 20+00 ±
 TIE TO EXISTING MARKINGS

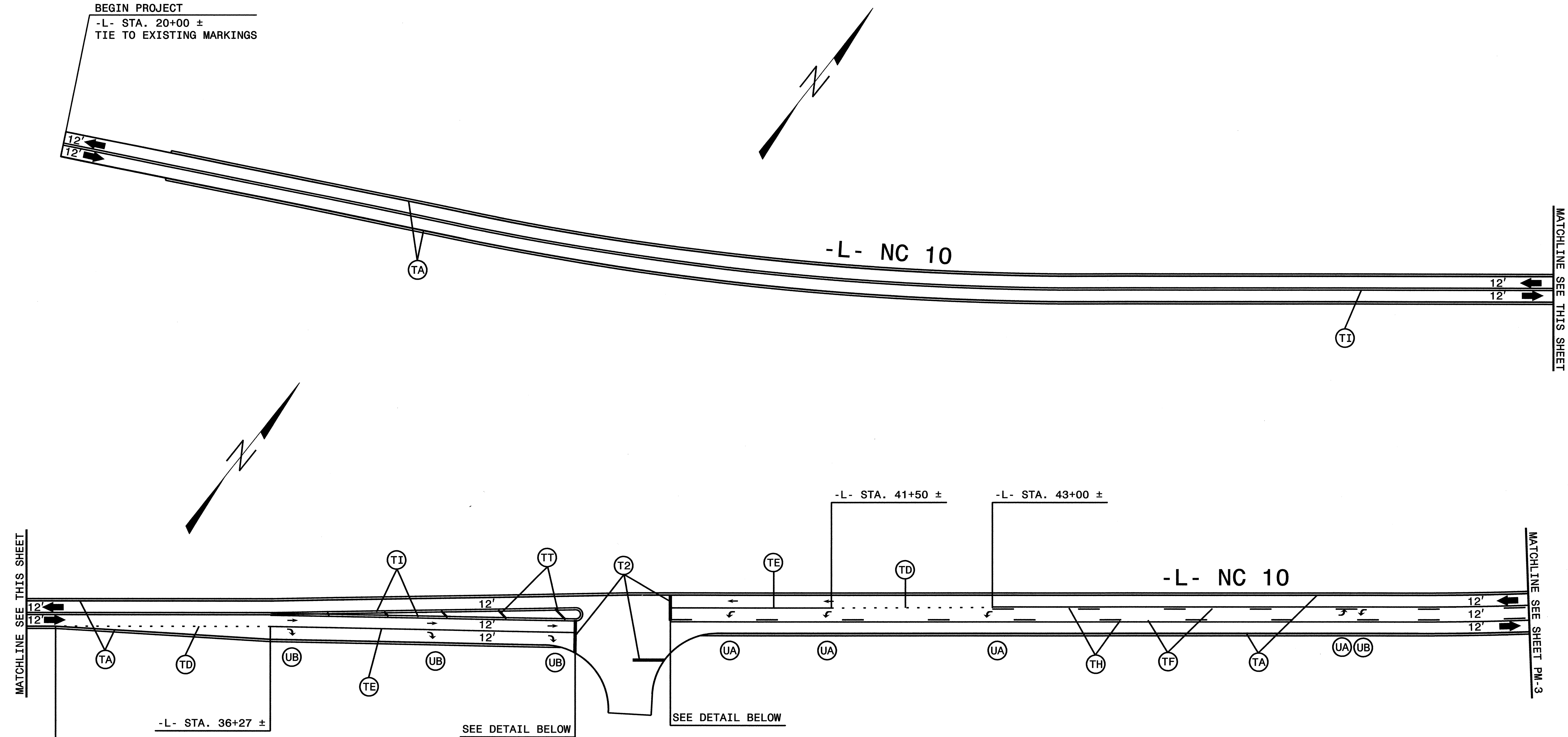

MATCHLINE SEE THIS SHEET

MATCHLINE SEE THIS SHEET

MATCHLINE SEE SHEET PM-3

-L- STA. 36+27 ±

-L- STA. 34+27 ±

SEE DETAIL BELOW

SEE DETAIL BELOW

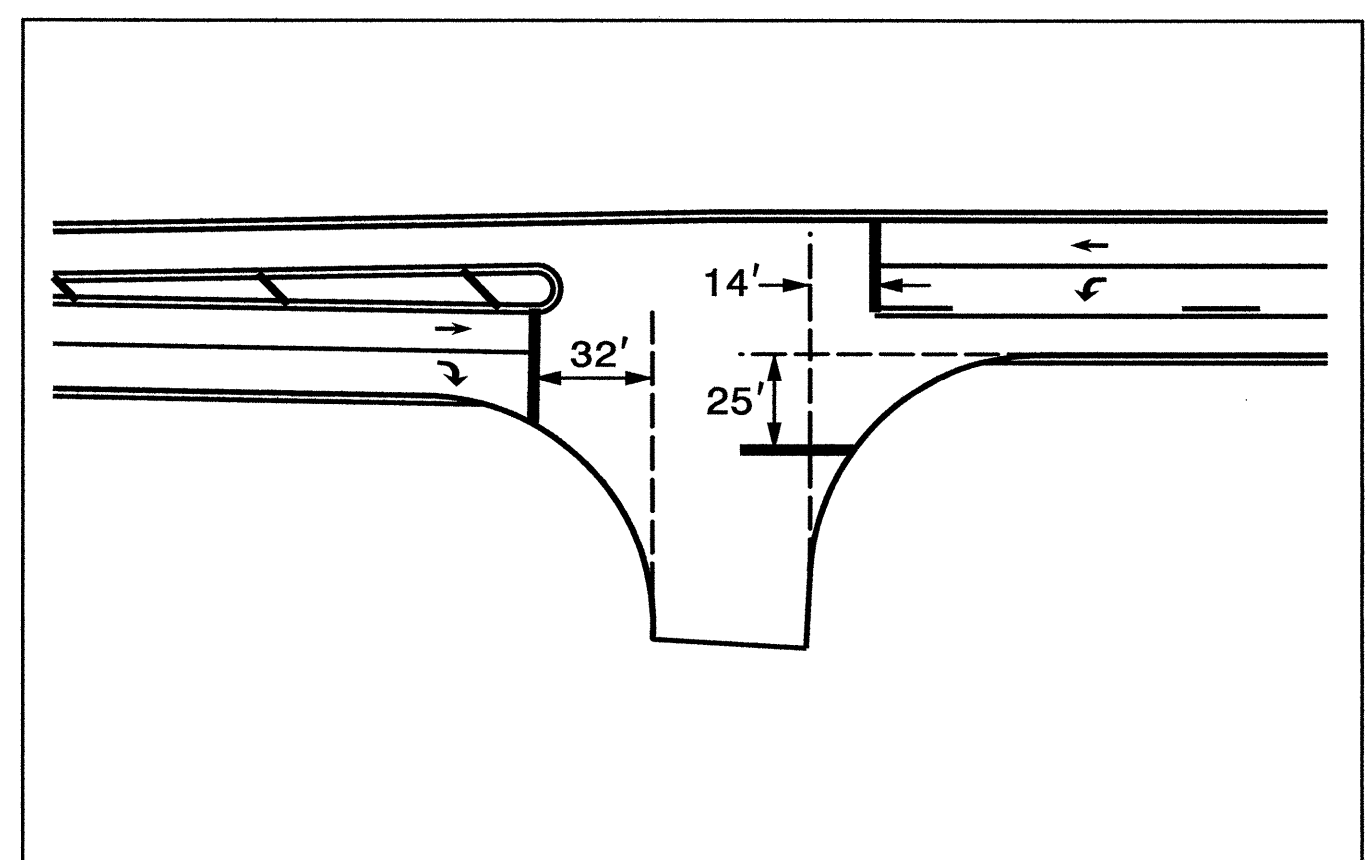

PROPOSED STOPBAR LOCATIONS
 TAKEN FROM SIGNAL PLANS

NOTES:
 -SEE SHEET PM-1, FOR FINAL PAVEMENT MARKING SCHEDULE.
 -PAVEMENT MARKINGS, SYMBOLS, AND CHARACTERS ARE TO BE MARKED ACCORDING TO ROADWAY STANDARD DRAWINGS UNLESS OTHERWISE NOTED IN THE PLANS.
 -PAVEMENT MARKERS ARE TO BE SPACED ACCORDING TO THE ROADWAY STANDARD DRAWINGS.

APPROVED: *[Signature]* DATE: 5/12/08

SEAL

FINAL PAVEMENT MARKING PLAN

SCALE: NONE		REVISIONS
DATE: 01-28		
DWG. BY: BKS		
DESIGN BY:		

REVIEWED BY:

\$\$\$\$\$SYTIME\$\$\$\$\$
 \$\$\$DON\$\$\$
 \$\$\$SERNAME\$\$\$

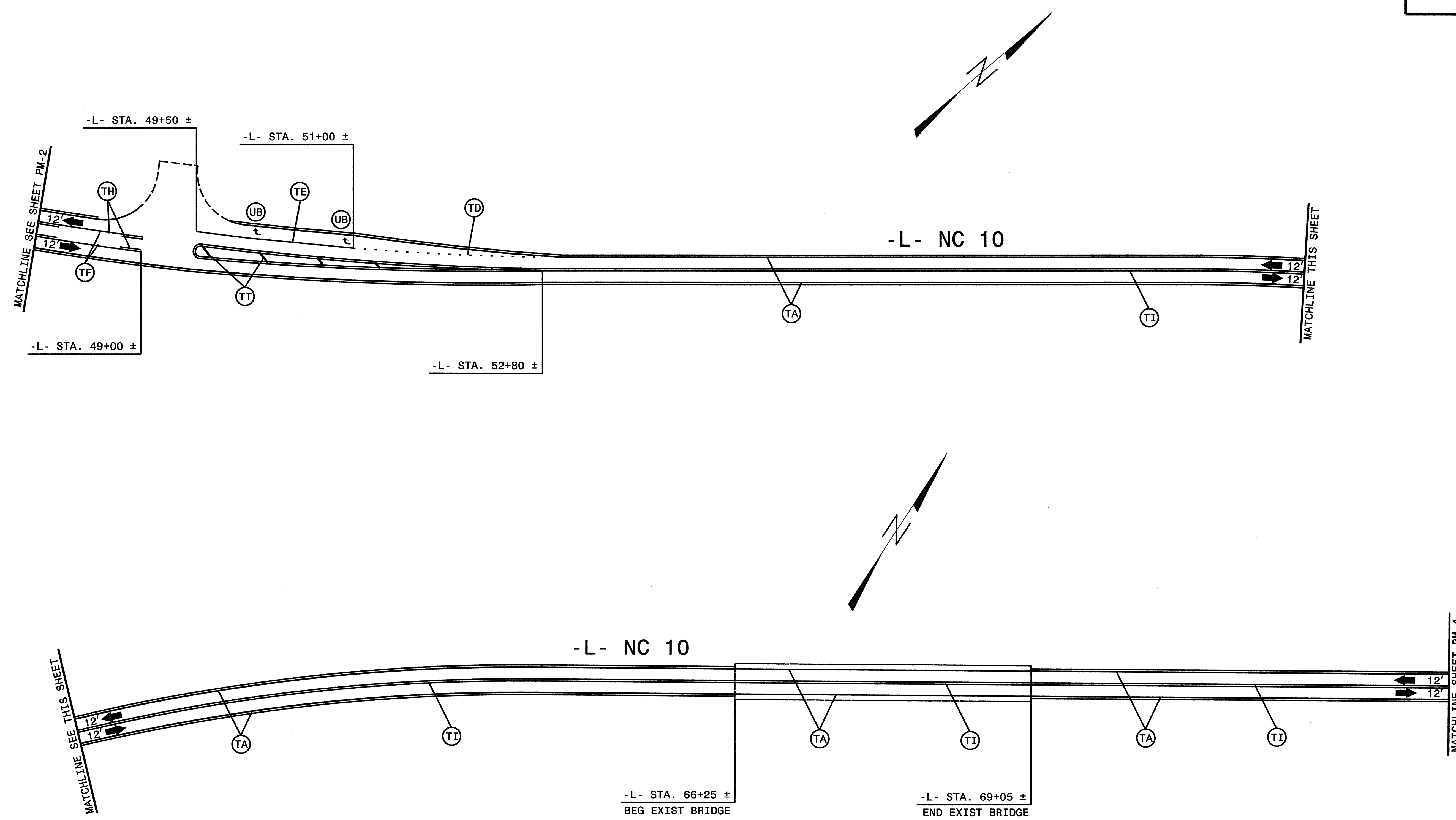

NOTES:

- SEE SHEET PM-1, FOR FINAL PAVEMENT MARKING SCHEDULE.
- PAVEMENT MARKINGS, SYMBOLS, AND CHARACTERS ARE TO BE MARKED ACCORDING TO ROADWAY STANDARD DRAWINGS UNLESS OTHERWISE NOTED IN THE PLANS.
- PAVEMENT MARKERS ARE TO BE SPACED ACCORDING TO THE ROADWAY STANDARD DRAWINGS.

APPROVED: *[Signature]* DATE: 2/12/02

SEAL

FINAL PAVEMENT MARKING PLAN

SCALE: NONE		REVISIONS
DATE: 01-28		
DWG. BY: BKS		
DESIGN BY:		
REVIEWED BY:		

CADD FILE

SYSTEM: \$\$\$\$\$\$
 USER: \$\$\$\$\$\$
 USERNAME: \$\$\$\$\$\$
 \$\$\$\$\$\$

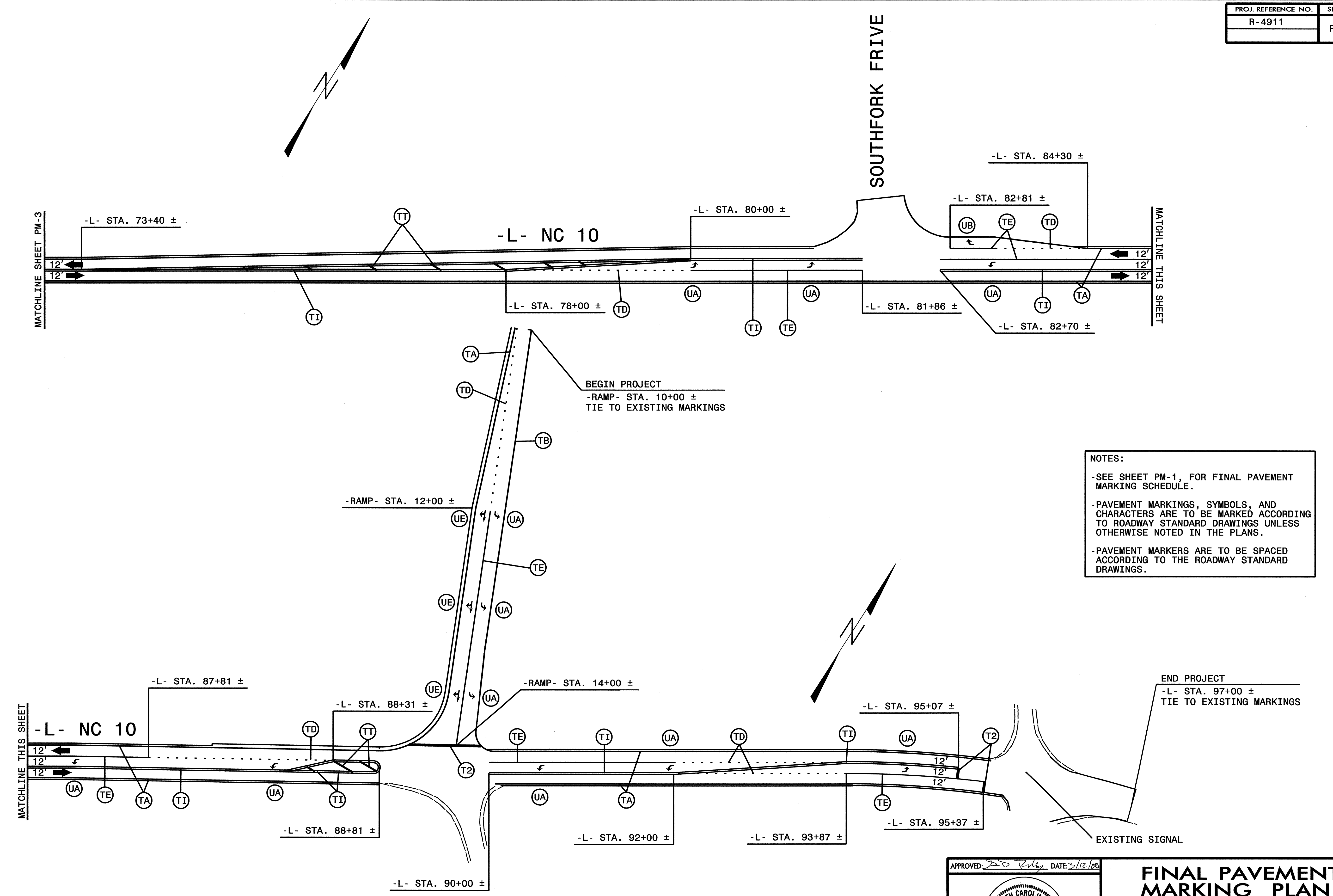

NOTES:

- SEE SHEET PM-1, FOR FINAL PAVEMENT MARKING SCHEDULE.
- PAVEMENT MARKINGS, SYMBOLS, AND CHARACTERS ARE TO BE MARKED ACCORDING TO ROADWAY STANDARD DRAWINGS UNLESS OTHERWISE NOTED IN THE PLANS.
- PAVEMENT MARKERS ARE TO BE SPACED ACCORDING TO THE ROADWAY STANDARD DRAWINGS.

APPROVED: *[Signature]* DATE: 3/12/08

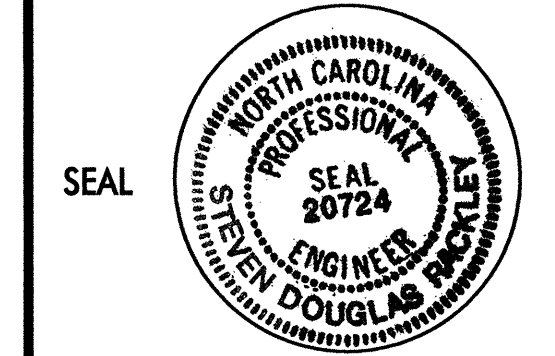

FINAL PAVEMENT MARKING PLAN

SCALE: NONE
 DATE: 01-28
 DWG. BY: BKS
 DESIGN BY:
 REVIEWED BY:

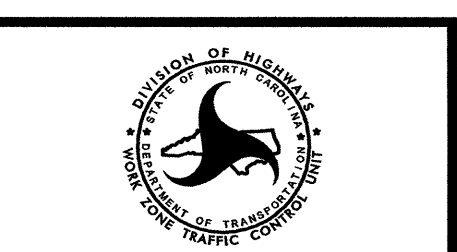

REVISIONS

SYSTEM: C:\DCI\SYSTEMS\USER\BKS