

09/08/799

See Sheet 1-A For Index of Sheets  
See Sheet 1-B For Conventional Symbols

T.I.P. NO.	SHEET NO.
B-4131	UO-1

STATE OF NORTH CAROLINA  
DIVISION OF HIGHWAYS

**UTILITIES BY OTHERS PLANS  
GUILFORD COUNTY**

**LOCATION: BRIDGE NO. 11 OVER BIG ALAMANCE CREEK ON  
SR 3394 (COMPANY MILL ROAD)**

**TYPE OF WORK: UTILITIES**

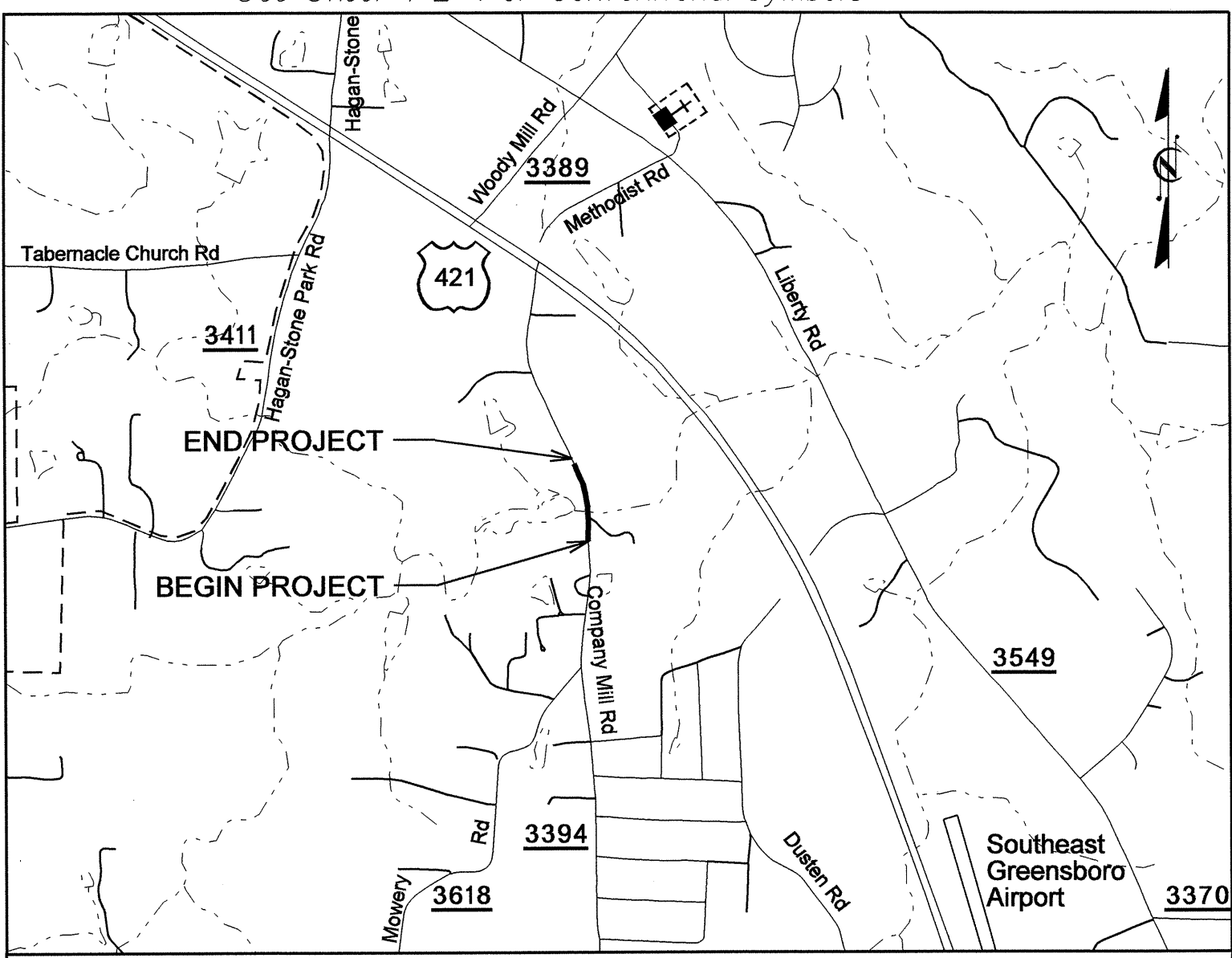

VICINITY MAP

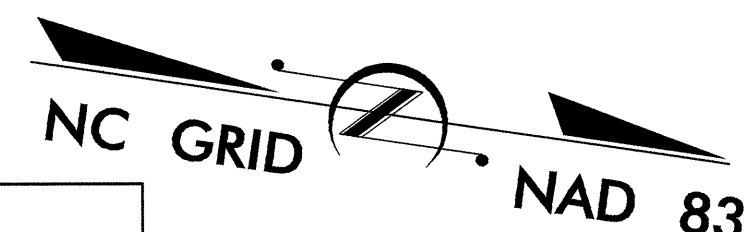

**UO-2  
4**

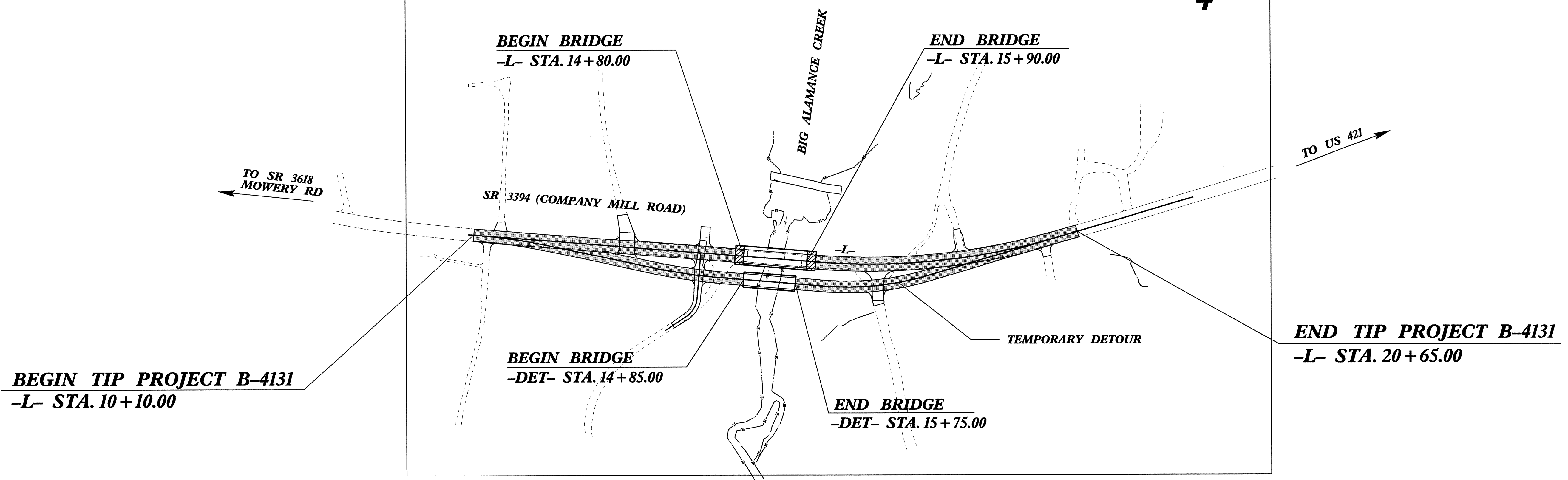

**TIP B-4131**

**CONTRACT:**

INDEX OF SHEETS	
SHEET NO.	DESCRIPTION
UO-1	TITLE SHEET
UO-2	UTILITIES BY OTHERS PLAN SHEET

UTILITY OWNERS ON PROJECT
(1) DUKE ENERGY
(2) AT&T
(3) TIME WARNER

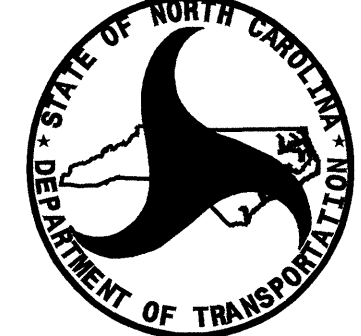

 PREPARED IN THE OFFICE OF:  
**DIVISION OF HIGHWAYS  
 DESIGN SERVICES  
 UTILITY SECTION**  
 1591 MAIL SERVICES CENTER  
 RALEIGH, NC 27699-1591  
 PHONE (919) 250-4128  
 FAX (919) 250-4119

**Roger Worthington, P.E.** UTILITIES SECTION ENGINEER  
**Steve Mckee, P.E.** UTILITIES SQUAD LEADER PROJECT ENGINEER  
**Alonza Yancey** UTILITIES PROJECT DESIGNER

06-NOV-2007 13:32  
 C:\utilities\rdy\ut\proj\4131\ut\_file\_uol\psh.dgn.dgn  
 \$\$\$USERNAME\$\$\$

**UTILITIES BY OTHERS**

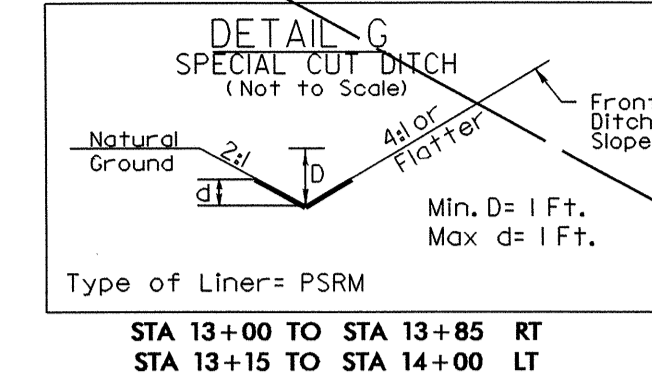
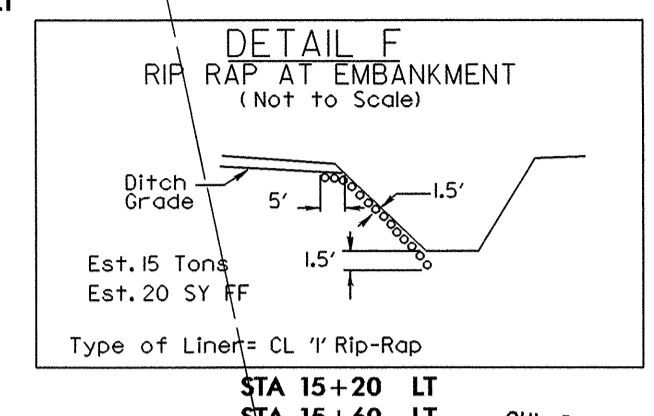
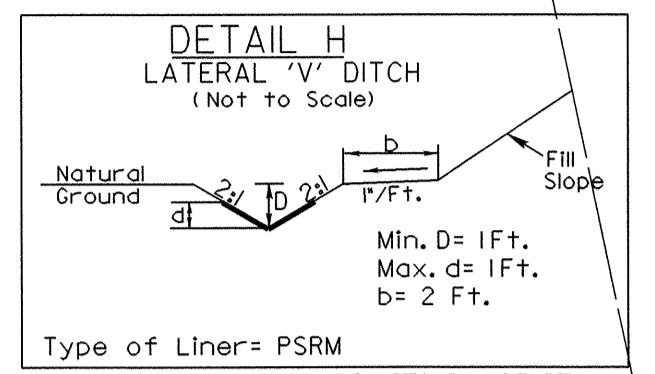
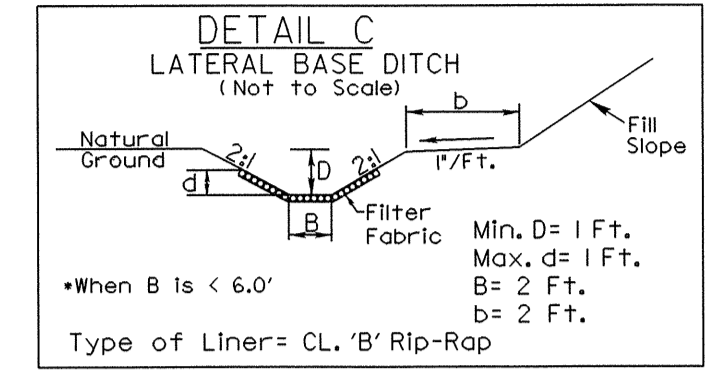
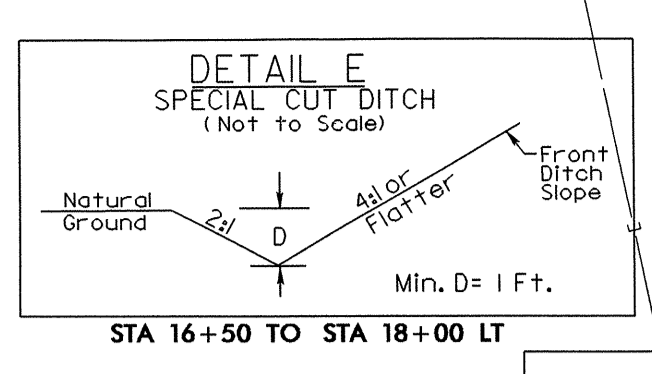
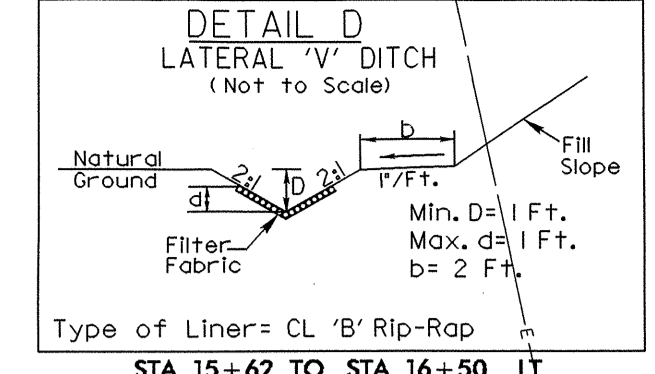
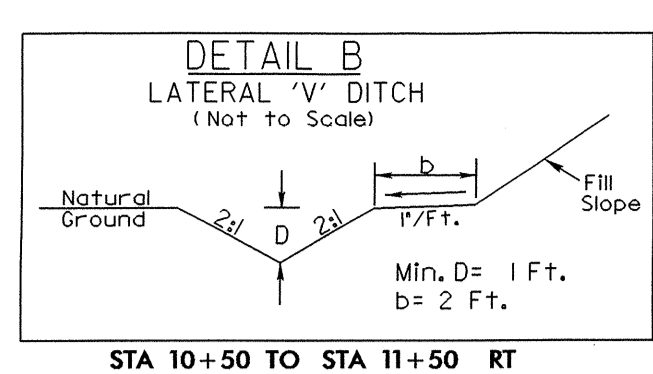
**NOTE:**  
ALL PROPOSED UTILITY WORK  
SHOWN ON THIS SHEET WILL  
BE DONE BY OTHERS



-L-  
PI Sta 18+20.66  
Δ = 2° 01' 33.5" (LT)  
D = 4' 58" 56.1"  
L = 422.02'  
T = 213.41'  
R = 1150.00'  
SE = 0.040  
DS = 50 mph

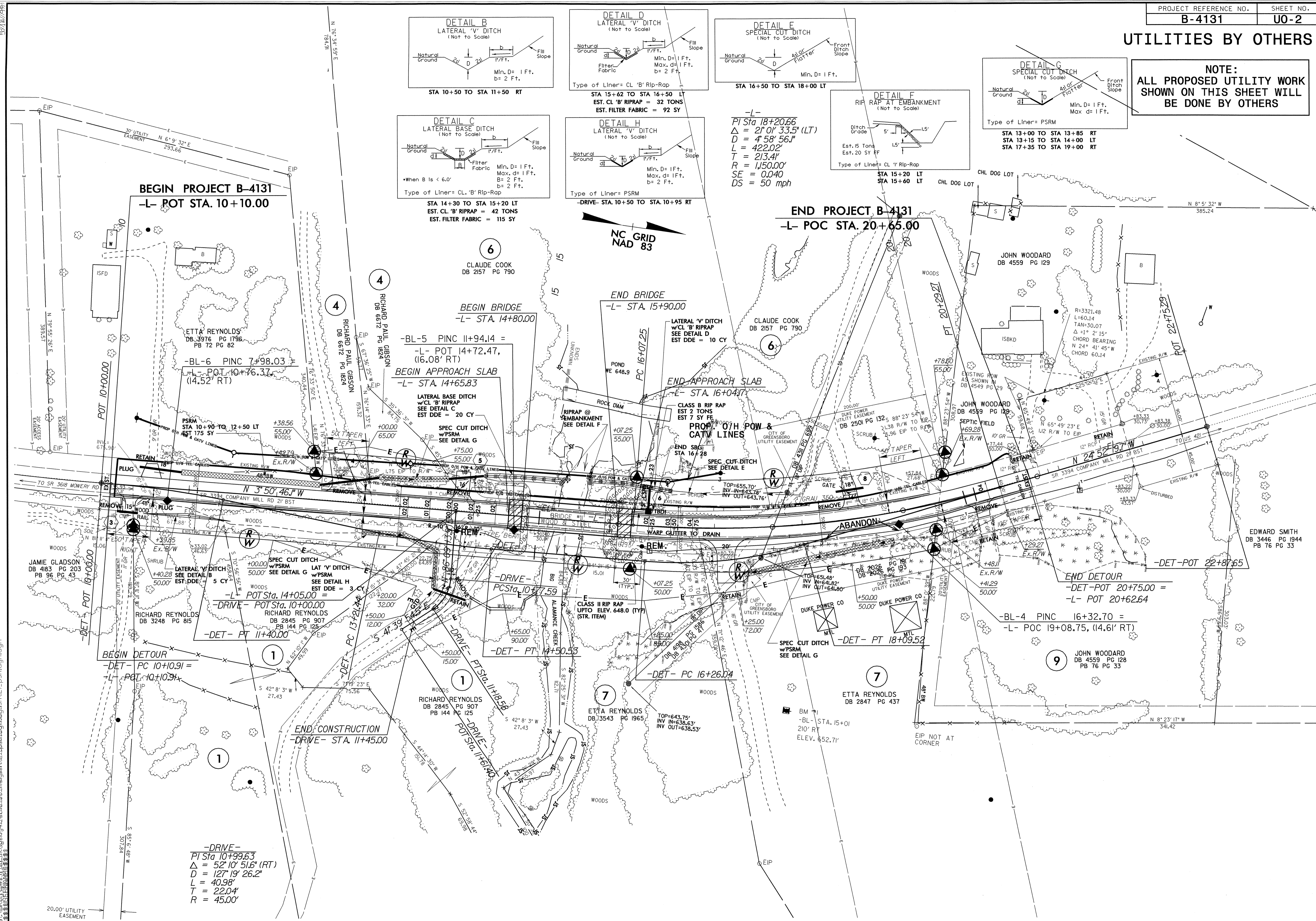

-DRIVE-  
PI Sta 10+99.63  
Δ = 52° 10' 51.6" (RT)  
D = 127' 19" 26.2"  
L = 40.98'  
T = 22.04'  
R = 45.00'

06-NOV-2007 15:33  
 r:\projects\2007\B-4131\utilities\sheet\2\psd.dgn  
 20.00' UTILITY EASEMENT