

PAVEMENT MARKING SCHEDULE

SYMBOL	DESCRIPTION	PAY ITEM/QUANTITY BREAKDOWN	TOTAL QUANTITY		SYMBOL	DESCRIPTION	PAY ITEM/QUANTITY BREAKDOWN	TOTAL QUANTITY	
<u>PAVEMENT MARKING LINES</u>					<u>PAVEMENT MARKING SYMBOLS</u>				
THERMOPLASTIC (4", 90 MILS)					THERMOPLASTIC THICK SYMBOL (90 MILS)				
TA	WHITE EDGELINE	32,482 FT	TOTAL	32,482 FT	UA	LEFT TURN ARROW	30 EA		
					UB	RIGHT TURN ARROW	6 EA		
								TOTAL 36 EA	
THERMOPLASTIC (4", 120 MILS)					THERMOPLASTIC THICK CHARACTER (120 MILS)				
TD	2 FT. WHITE MINISKIP	473 FT			UI	ALPHANUMERIC CHARACTER	12 EA		
TE	WHITE SOLID LANE LINE	1,250 FT						TOTAL 12 EA	
TF	10 FT. YELLOW SKIP	2,958 FT							
TH	YELLOW SINGLE CENTER	11,396 FT							
TI	YELLOW DOUBLE CENTER	17,136 FT	TOTAL	33,213 FT	<u>PAINT SYMBOL</u>				
THERMOPLASTIC (8", 90 MILS)					PAINT CHARACTER				
TP	WHITE GORELINE	50 FT			QA	LEFT TURN ARROW	30 EA		
TQ	WHITE DIAGONAL	17 FT			QB	RIGHT TURN ARROW	6 EA		
TT	YELLOW DIAGONAL	547 FT	TOTAL	64 FT				TOTAL 36 EA	
THERMOPLASTIC (24", 120 MILS)					<u>PAVEMENT MARKERS</u>				
T2	WHITE TRANSVERSE BAND	72 FT	TOTAL	72 FT	PERMANENT RAISED				
PAINT (4")					TEMPORARY RAISED				
PA	WHITE EDGELINE	64,964 FT			MA	YELLOW & YELLOW	420 EA		
PD	2 FT. WHITE MINISKIP	946 FT			MB	CRYSTAL & RED	153 EA		
PE	WHITE SOLID LANE LINE	2,500 FT						TOTAL 573 EA	
PF	10 FT. YELLOW SKIP	5,915 FT							
PH	YELLOW SINGLE CENTER	22,792 FT			MH	YELLOW & YELLOW	420 EA		
PI	YELLOW DOUBLE CENTER	34,272 FT	TOTAL	131,389 FT	MI	CRYSTAL & RED	153 EA		
PAINT (8")					TOTAL 573 EA				
PR	WHITE GORELINE	100 FT							
PS	WHITE DIAGONAL	34 FT							
PV	YELLOW DIAGONAL	1,094 FT	TOTAL	1,228					
PAINT (24")									
P4	WHITE TRANSVERSE BAND	72 FT	TOTAL	72 FT					

9/18/2007 11:43:52 AM
 C:\P\work\king\TPA\dms17157\R-5017-RDY_PMP1_050120.dgn

APPROVED: <i>Lisa Podestina</i> DATE: 9/20/07 	<h2 style="margin: 0;">PAVEMENT MARKING SCHEDULE</h2>	<table border="1" style="width: 100%; border-collapse: collapse;"> <tr> <td>SCALE: NONE</td> <td rowspan="4" style="text-align: center;">  </td> <td>REVISIONS</td> </tr> <tr> <td>DATE: OCT 2006</td> <td></td> </tr> <tr> <td>DWG. BY: WPH</td> <td></td> </tr> <tr> <td>DESIGN BY: WPH</td> <td></td> </tr> <tr> <td>REVIEWED BY: LMP</td> <td></td> <td></td> </tr> </table>	SCALE: NONE		REVISIONS	DATE: OCT 2006		DWG. BY: WPH		DESIGN BY: WPH		REVIEWED BY: LMP		
SCALE: NONE		REVISIONS												
DATE: OCT 2006														
DWG. BY: WPH														
DESIGN BY: WPH														
REVIEWED BY: LMP														

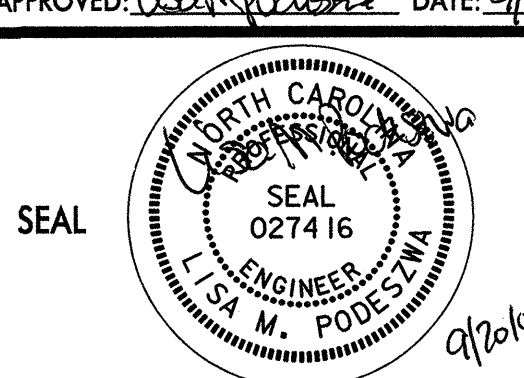
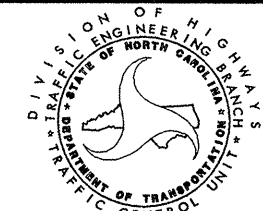
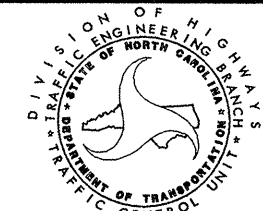
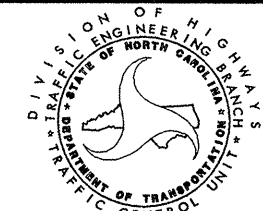
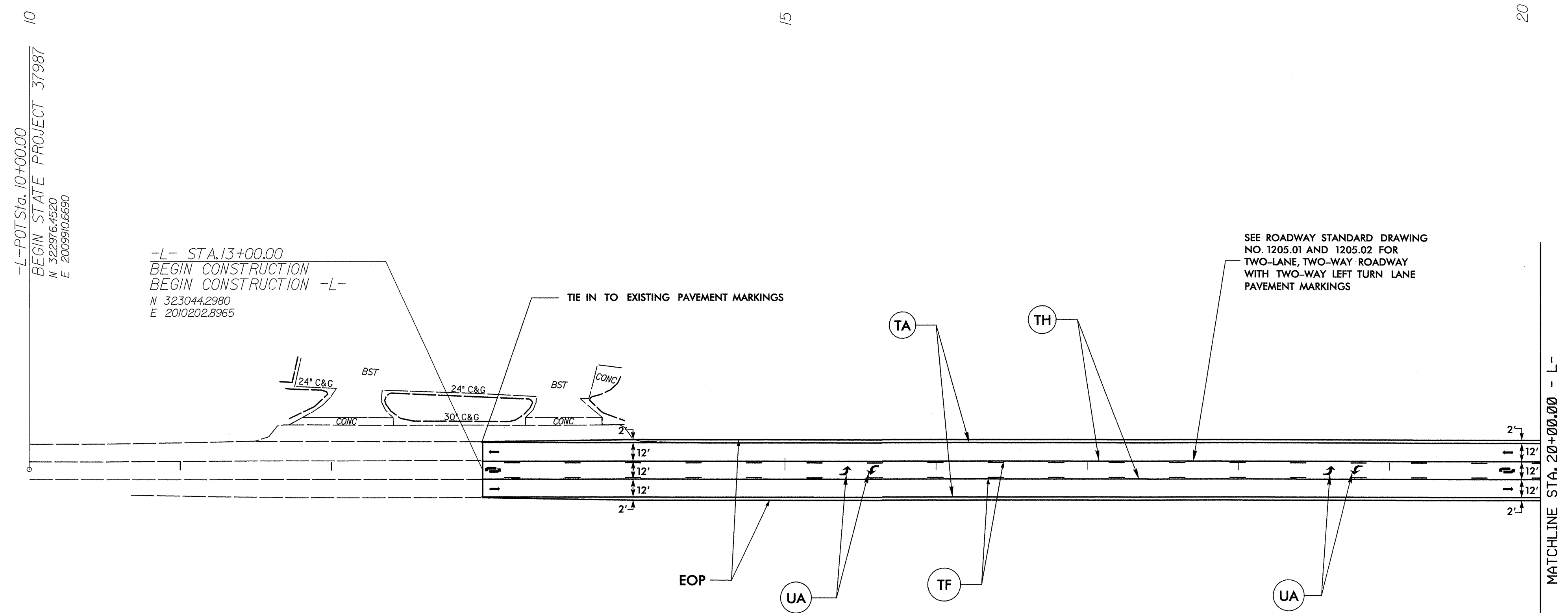
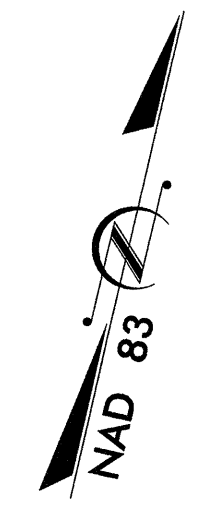

-L- POT Sta. 10+00.00
 BEGIN STATE PROJECT 37987
 N 322976.4520
 E 2009910.6690

-L- STA. 13+00.00
 BEGIN CONSTRUCTION
 BEGIN CONSTRUCTION -L-
 N 323044.2980
 E 2010202.8965

SEE ROADWAY STANDARD DRAWING
 NO. 1205.01 AND 1205.02 FOR
 TWO-LANE, TWO-WAY ROADWAY
 WITH TWO-WAY LEFT TURN LANE
 PAVEMENT MARKINGS

MATCHLINE STA. 20+00.00 - L-

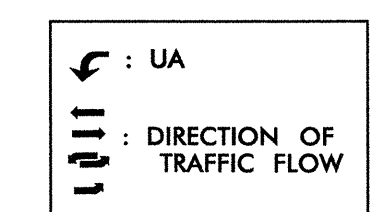

SEE SHEET PM-1 FOR MARKING SCHEDULE.
 SEE ROADWAY STANDARD DRAWING NO.
 1250.01 AND 1251.01 FOR PAVEMENT MARKER
 SPACING AND RAISED PAVEMENT MARKERS.

APPROVED: <i>[Signature]</i> DATE: 9/24/07	PAVEMENT MARKING		REVISIONS	
			SCALE: NONE	
	DATE: SEPT 2006			
	DWG. BY: DHK DESIGN BY: DHK REVIEWED BY: LMP			

20
25
5

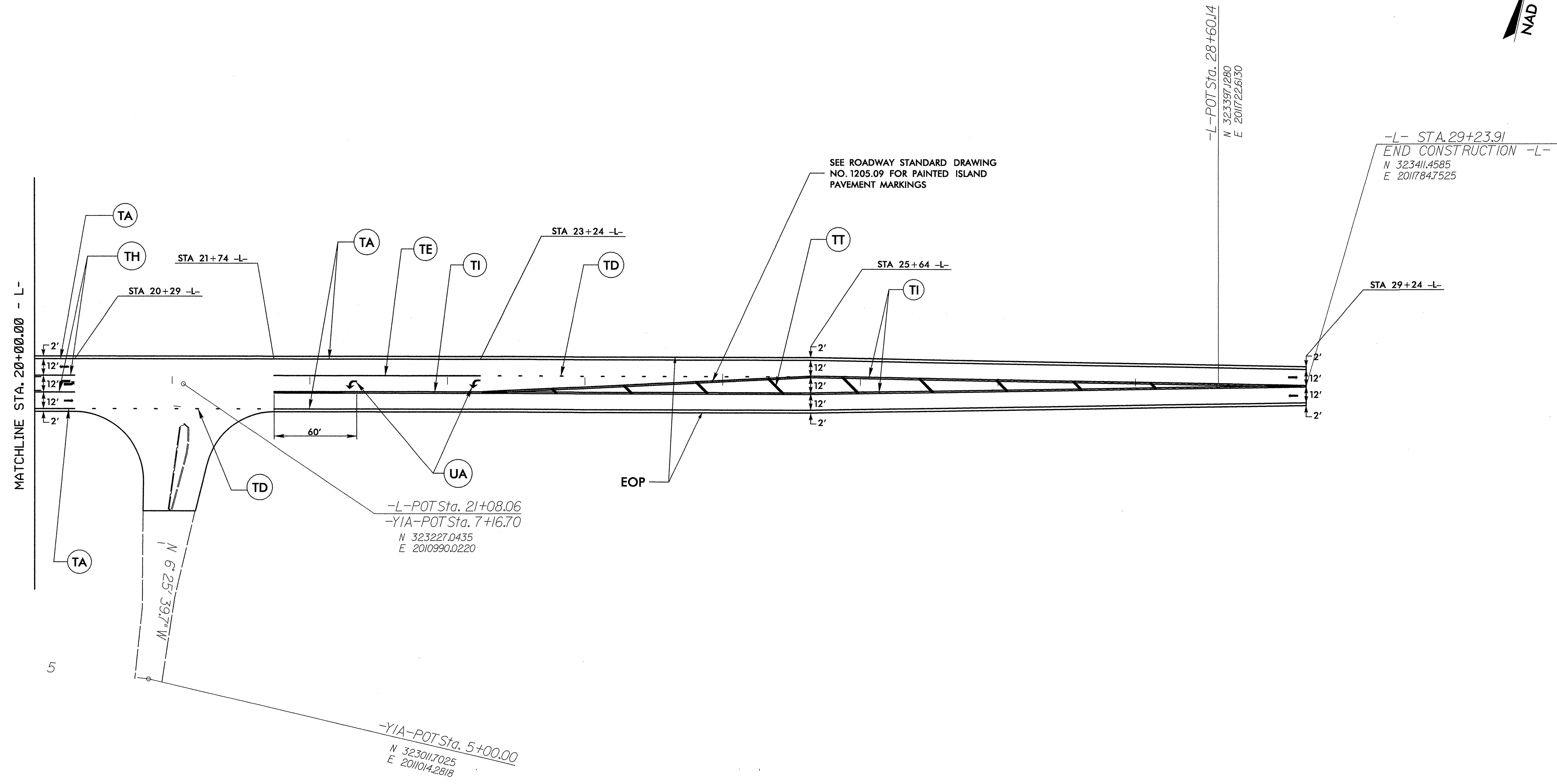
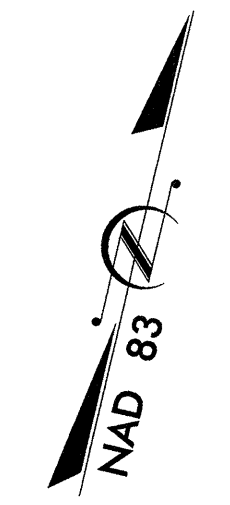

SEE ROADWAY STANDARD DRAWING NO. 1205.09 FOR PAINTED ISLAND PAVEMENT MARKINGS

-L- STA. 29+23.91
END CONSTRUCTION -L-
N 323411.4585
E 20117847.525

-L-POT Sta. 21+08.06
-YIA-POT Sta. 7+16.70
N 323227.0435
E 2010990.0220

-YIA-POT Sta. 5+00.00
N 323011.7025
E 2010104.2818

-L-POT Sta. 28+60.14
N 323397.1280
E 20117226.50

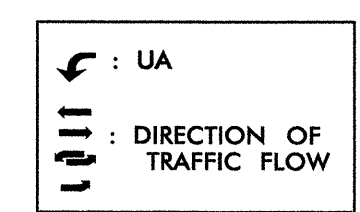

SEE SHEET PM-1 FOR MARKING SCHEDULE.
SEE ROADWAY STANDARD DRAWING NO. 1250.01 AND 1251.01 FOR PAVEMENT MARKER SPACING AND RAISED PAVEMENT MARKERS.

APPROVED: <i>Lisa M. Podestina</i> DATE: 9/16/07	PAVEMENT MARKING	
	SCALE: NONE	
	DATE: SEPT 2006	
	DWG. BY: DHK	
	DESIGN BY: DHK	
REVIEWED BY: LMP	REVISIONS	

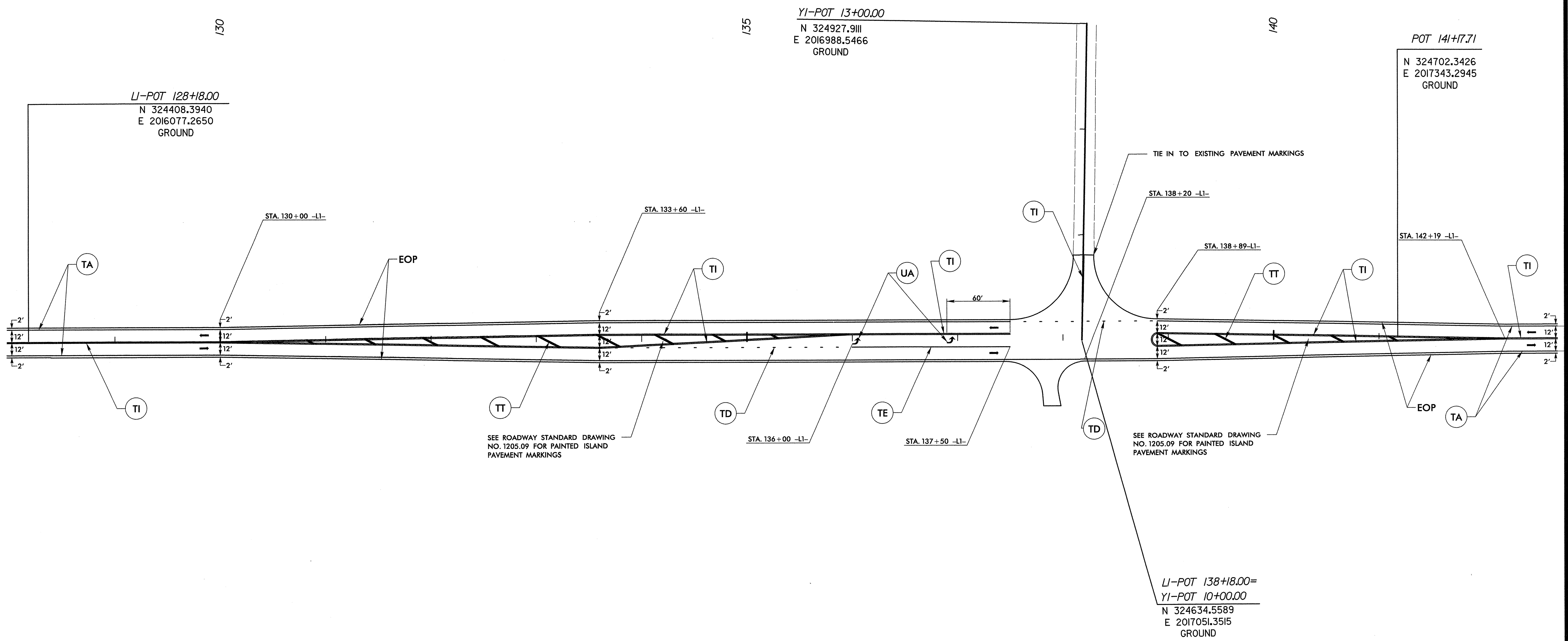
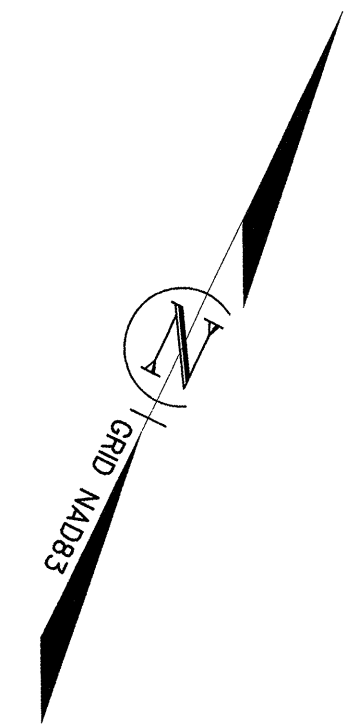

SEE ROADWAY STANDARD DRAWING NO. 1205.09 FOR PAINTED ISLAND PAVEMENT MARKINGS

SEE ROADWAY STANDARD DRAWING NO. 1205.09 FOR PAINTED ISLAND PAVEMENT MARKINGS

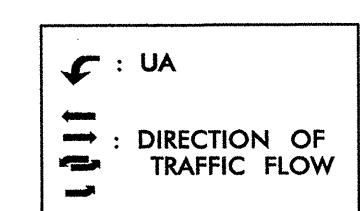

SEE SHEET PM-1 FOR MARKING SCHEDULE.
SEE ROADWAY STANDARD DRAWING NO. 1250.01 AND 1251.01 FOR PAVEMENT MARKER SPACING AND RAISED PAVEMENT MARKERS.

APPROVED: <i>[Signature]</i> DATE: 9/20/07	PAVEMENT MARKING		REVISIONS							
			SCALE: NONE		<table border="1"> <tr><td> </td><td> </td></tr> <tr><td> </td><td> </td></tr> <tr><td> </td><td> </td></tr> </table>					
DATE: AUG 2007	DESIGN BY: DK	REVIEWED BY: MP	<table border="1"> <tr><td> </td><td> </td></tr> <tr><td> </td><td> </td></tr> </table>							
DWG. BY: HM										

9/18/2007 11:42:21AM C:\pwworking\TPA\dms83140\R-5017_rdy_pmp4.dgn

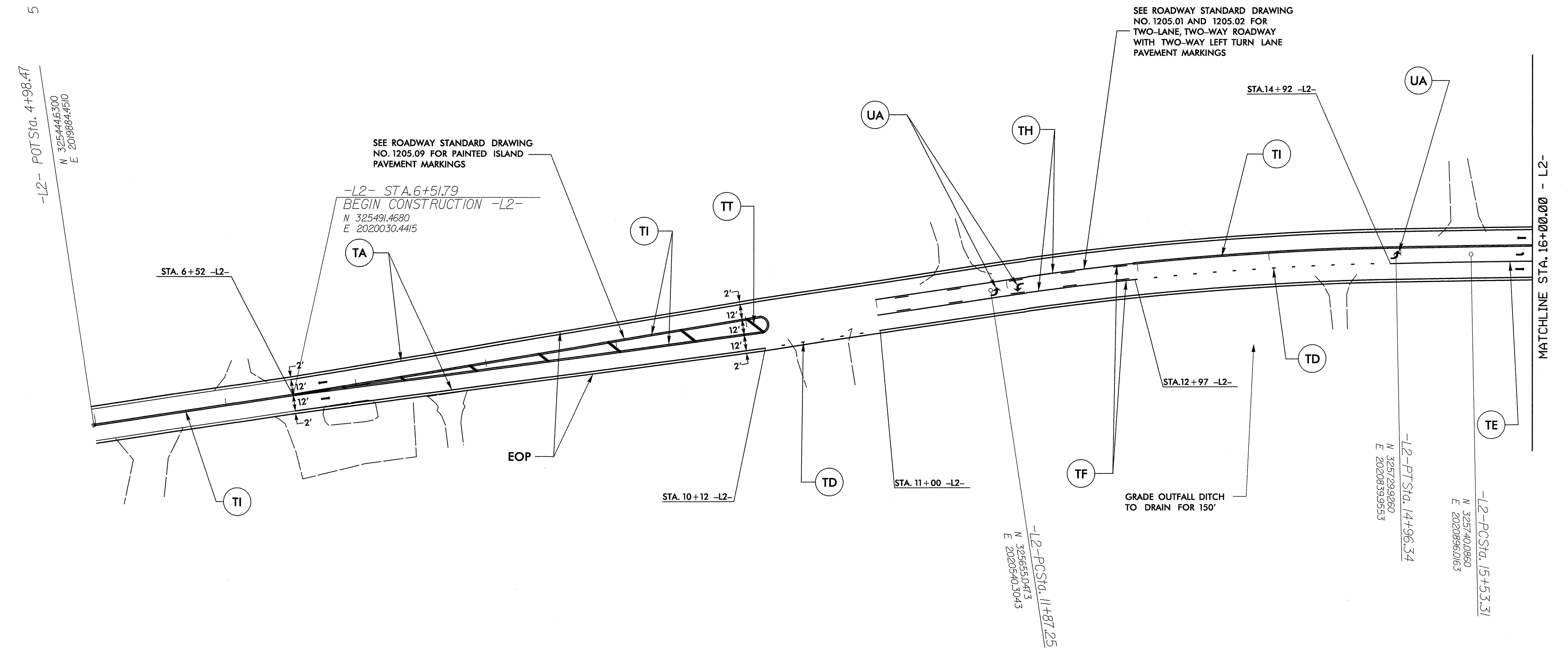

9/18/2007 11:42:52 AM C:\pwworking\TPA\dms1757\AR-5017-RDY_PMP5_050120.dgn

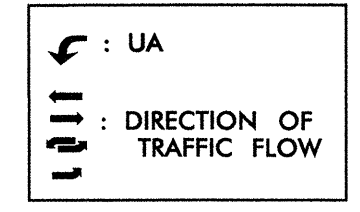

SEE SHEET PM-1 FOR MARKING SCHEDULE.
SEE ROADWAY STANDARD DRAWING NO. 1250.01 AND 1251.01 FOR PAVEMENT MARKER SPACING AND RAISED PAVEMENT MARKERS.

APPROVED: <i>[Signature]</i> DATE: 9/18/07	PAVEMENT MARKING	
	SCALE: NONE	
	DATE: SEPT 2006	
	DWG. BY: DHK	
	DESIGN BY: DHK	
REVIEWED BY: LMP	REVISIONS	

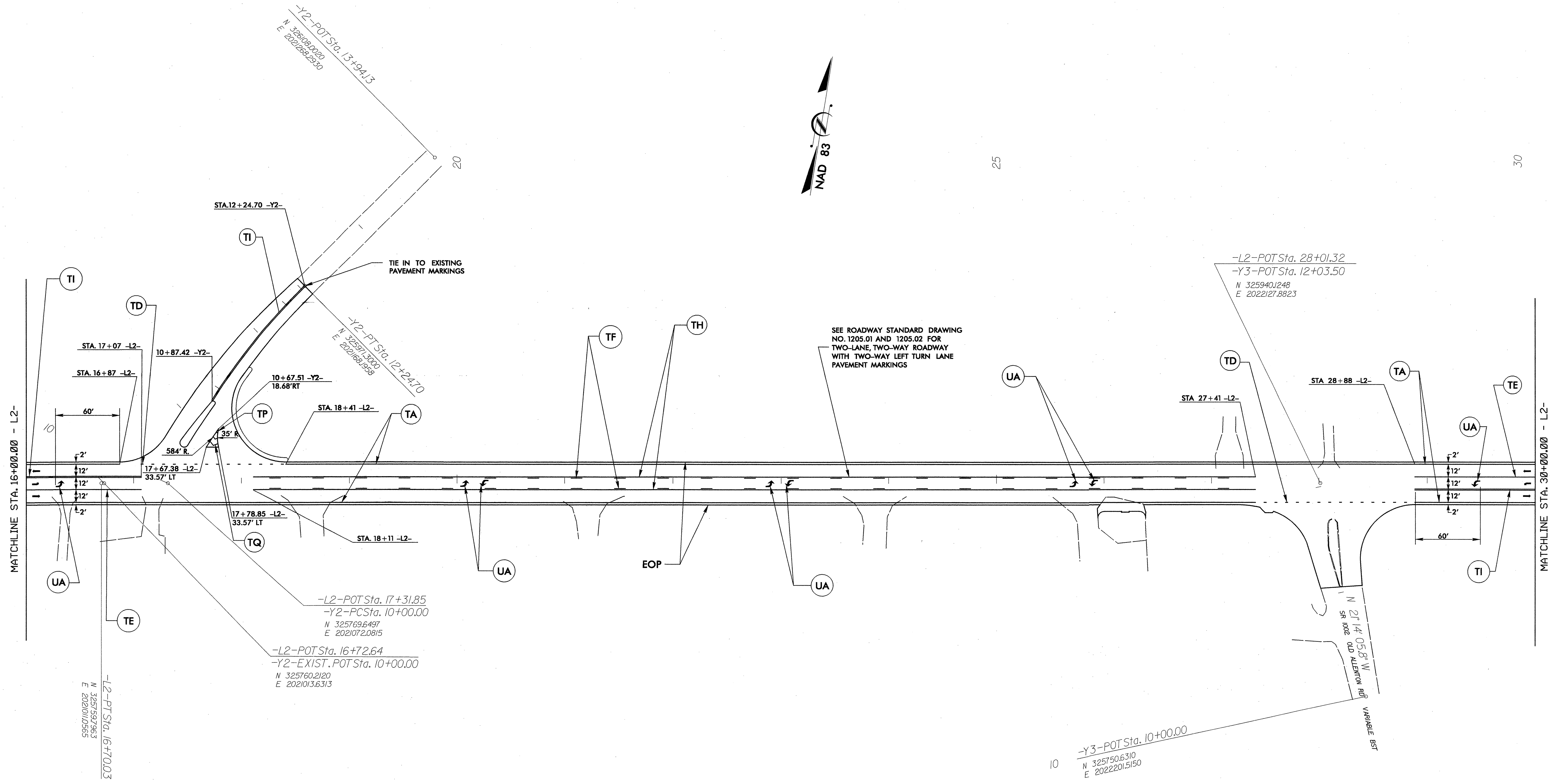

SEE ROADWAY STANDARD DRAWING NO. 1205.01 AND 1205.02 FOR TWO-LANE, TWO-WAY ROADWAY WITH TWO-WAY LEFT TURN LANE PAVEMENT MARKINGS

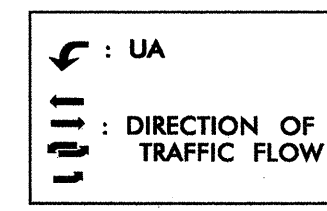

SEE SHEET PM-1 FOR MARKING SCHEDULE.
SEE ROADWAY STANDARD DRAWING NO. 1250.01 AND 1251.01 FOR PAVEMENT MARKER SPACING AND RAISED PAVEMENT MARKERS.

APPROVED: <i>[Signature]</i> DATE: 9/7/07	PAVEMENT MARKING									
SCALE: NONE	DATE: SEPT 2006	<table border="1"> <tr> <th colspan="2">REVISIONS</th> </tr> <tr> <td> </td> <td> </td> </tr> <tr> <td> </td> <td> </td> </tr> <tr> <td> </td> <td> </td> </tr> </table>	REVISIONS							
REVISIONS										
DWG. BY: DHK	DESIGN BY: DHK	<table border="1"> <tr> <td>REVIEWED BY: LMP</td> <td>CADD FILE</td> </tr> </table>	REVIEWED BY: LMP	CADD FILE						
REVIEWED BY: LMP	CADD FILE									

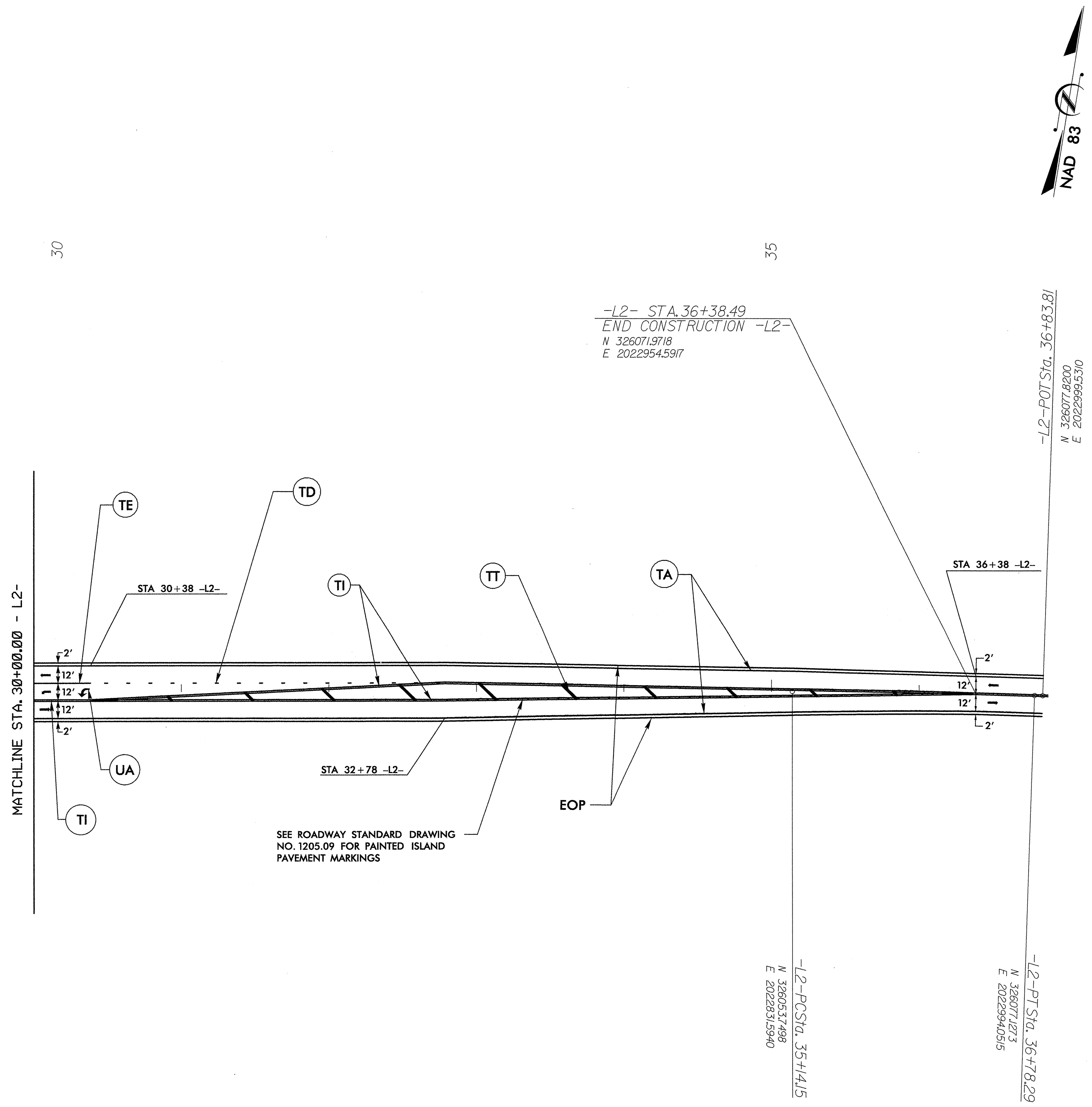

9/18/2007 11:43:01 AM
 C:\P\Work\King\TPA\dms17157AR-5017_RDY_PMP7_050120.dgn

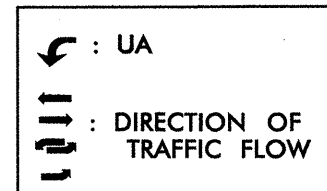

SEE SHEET PM-1 FOR MARKING SCHEDULE.
 SEE ROADWAY STANDARD DRAWING NO. 1250.01 AND 1251.01 FOR PAVEMENT MARKER SPACING AND RAISED PAVEMENT MARKERS.

APPROVED: *[Signature]* DATE: 9/14/06

PAVEMENT MARKING

SCALE: NONE
 DATE: SEPT 2006
 DWG. BY: DHK
 DESIGN BY: DHK
 REVIEWED BY: LMP

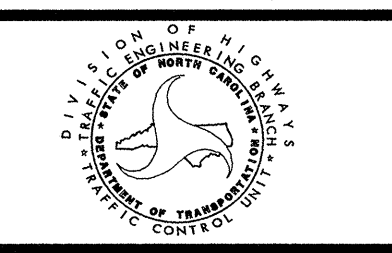

REVISIONS	



45

50

55

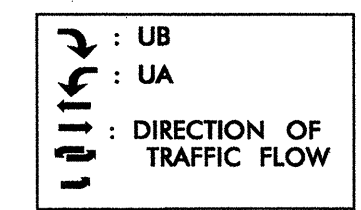
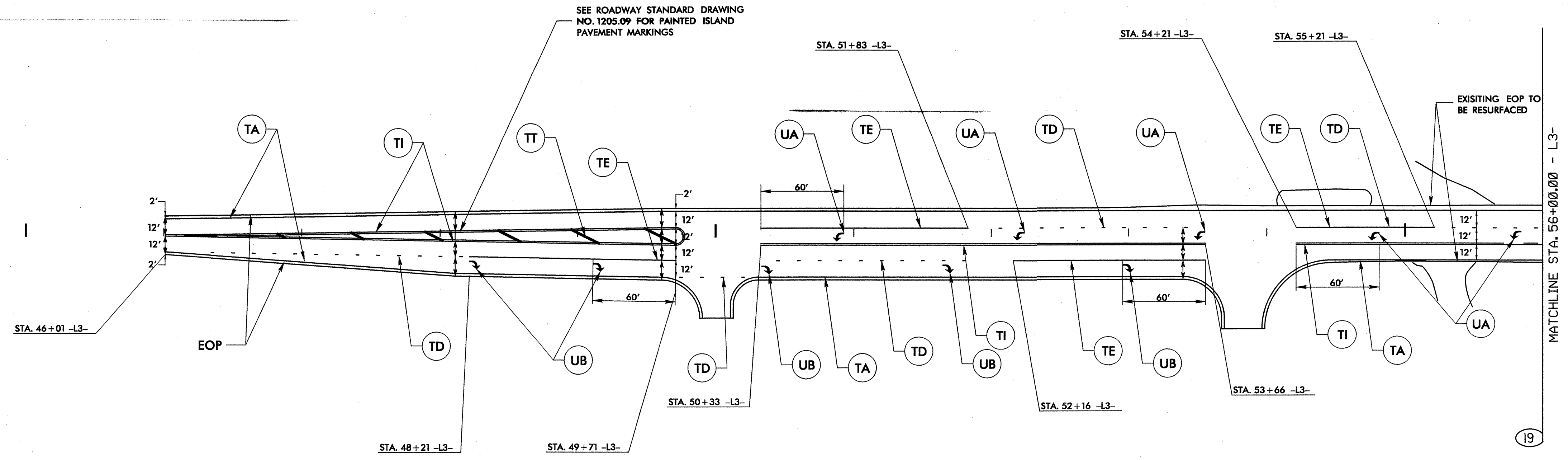

SEE SHEET PM-1 FOR MARKING SCHEDULE.
 SEE ROADWAY STANDARD DRAWING NO. 1250.01 AND 1251.01 FOR PAVEMENT MARKER SPACING AND RAISED PAVEMENT MARKERS.
 PLACE "SCHOOL" PAVEMENT MARKINGS PER ROADWAY STANDARD DRAWING NO. 1205.08 SHEET 2.

APPROVED: *[Signature]* DATE: 9/20/07

9/20/07

PAVEMENT MARKING

SCALE: NONE		REVISIONS
DATE:		
DWG. BY:		
DESIGN BY:		
REVIEWED BY:		

9/18/2007
 9:41:00 AM
 C:\pwworking\TPA\smis83140\NR-5017_rdy.pmp8.dgn

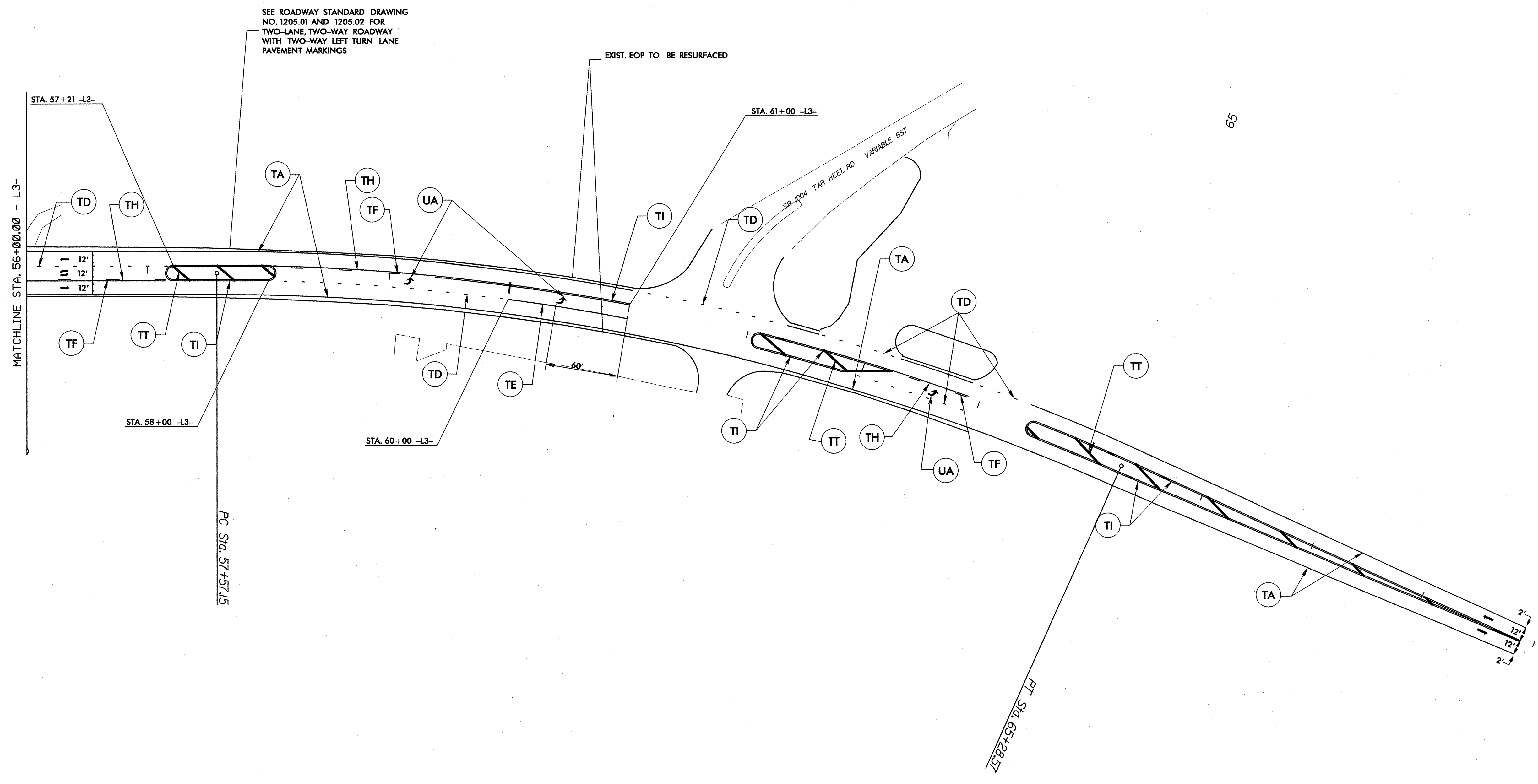

9/18/2007 6:24:53 PM C:\P\working\TPA\dms8340\R-5017_r.dwg pmp9.dgn

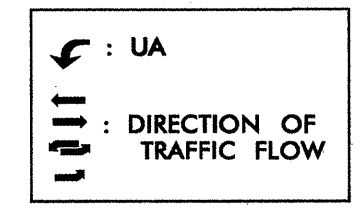

SEE SHEET PM-1 FOR MARKING SCHEDULE.

SEE ROADWAY STANDARD DRAWING NO. 1250.01 AND 1251.01 FOR PAVEMENT MARKER SPACING AND RAISED PAVEMENT MARKERS.

PLACE "SCHOOL" PAVEMENT MARKINGS PER ROADWAY STANDARD DRAWING NO. 1205.08 SHEET 2.

APPROVED: *Use in future* DATE: 9/20/07

SEAL

9/20/07

PAVEMENT MARKING

SCALE: NONE		REVISIONS
DATE:		
DWG. BY:		
DESIGN BY:		
REVIEWED BY:		
CADD FILE		