

APPENDIX D.1B: FIELD DATA SHEETS - HIGH BENT SPANS

Field Sheet Notation Legend	
CK/CR	Crack (width noted in inches)
CS/RS	Corrosion/rust stain
CS AGG	Corrosion stain at exposed aggregate
DIA	Diaphragm
DIAG	Diagonal
DL	Delamination
EF	Efflorescence
ER	Exposed rebar
ERx2	2 exposed bars
ES	Exposed prestressing strand
ESx2	2 exposed strands
HL CK	Hairline crack
HVY	Heavy
PTH	Patch
SP	Spall
SR	Shotcrete repair
-0.XXX V	Half-cell potential measurement in volts
XXX μ s	Ultrasonic pulse velocity measurement in micro seconds

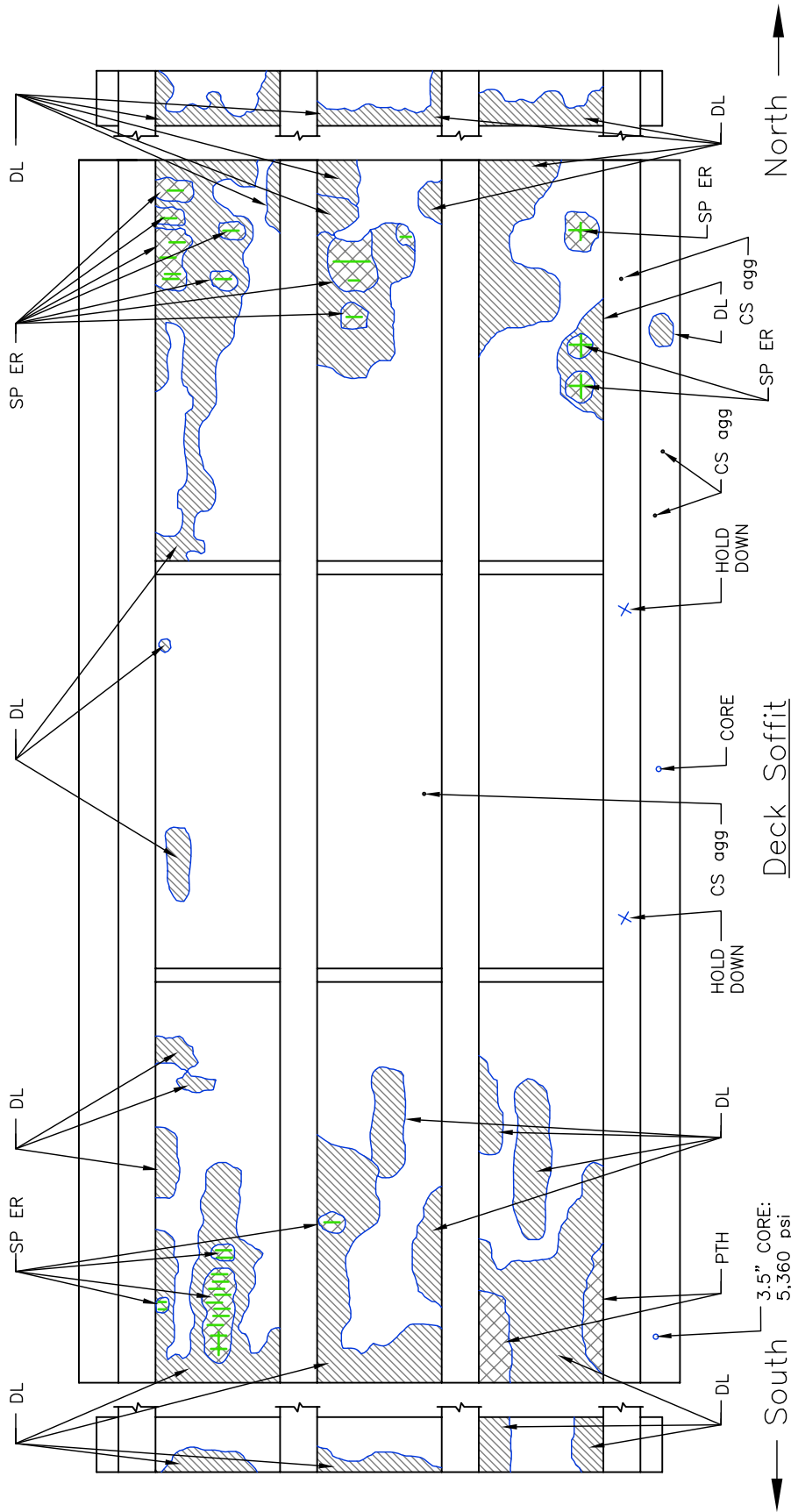

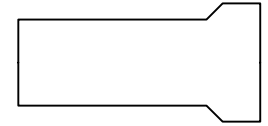
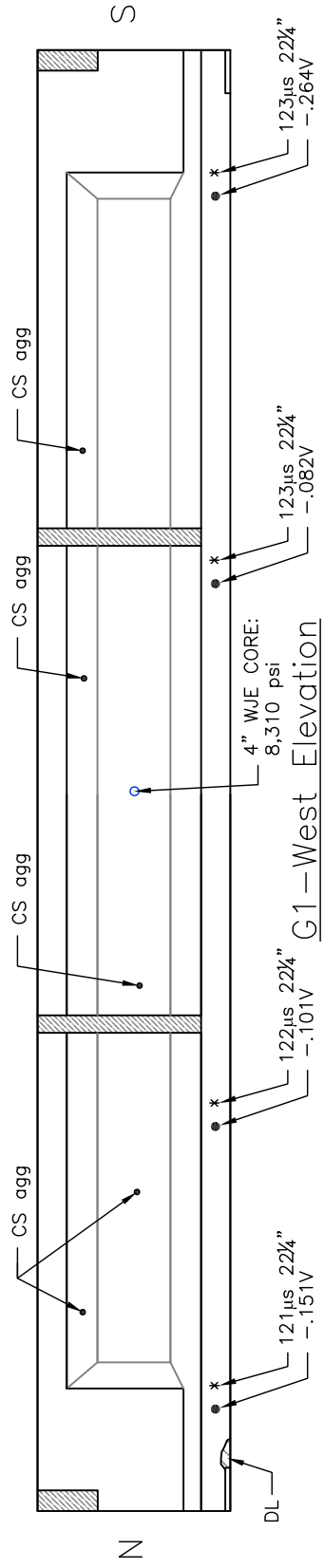
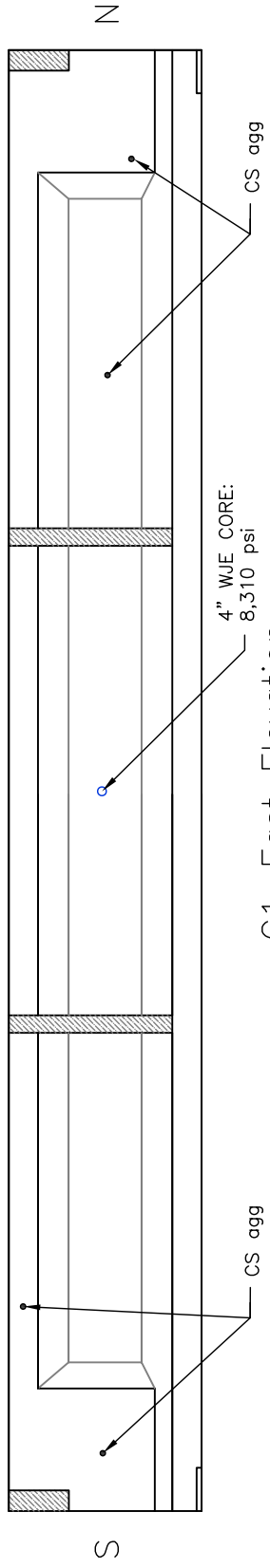

North End

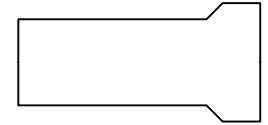

South End

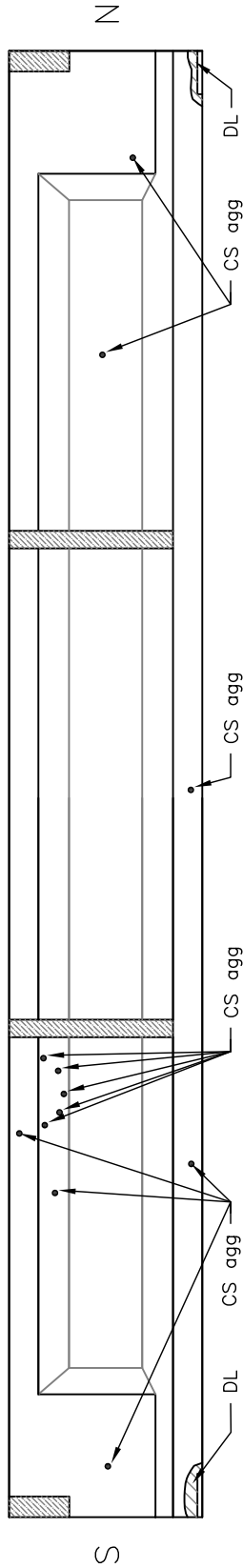

G2--East Elevation

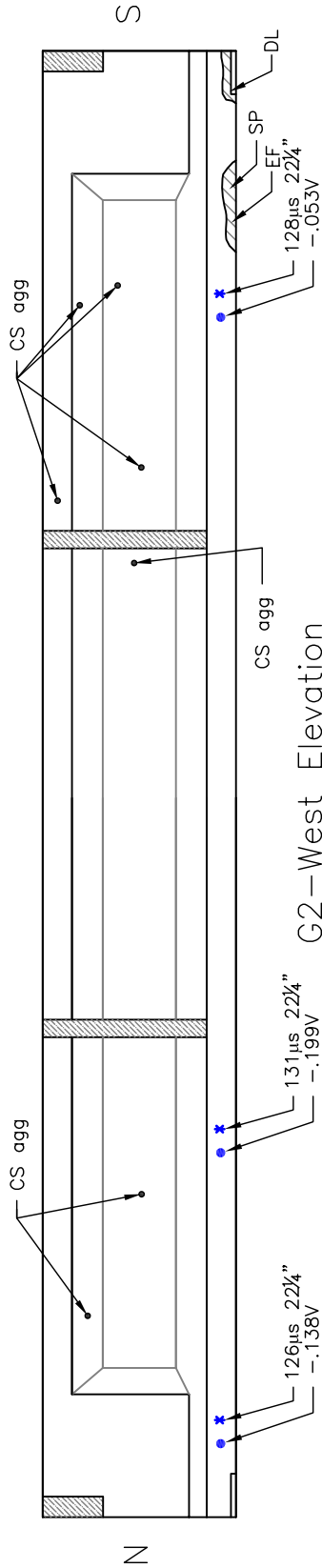

G2--West Elevation



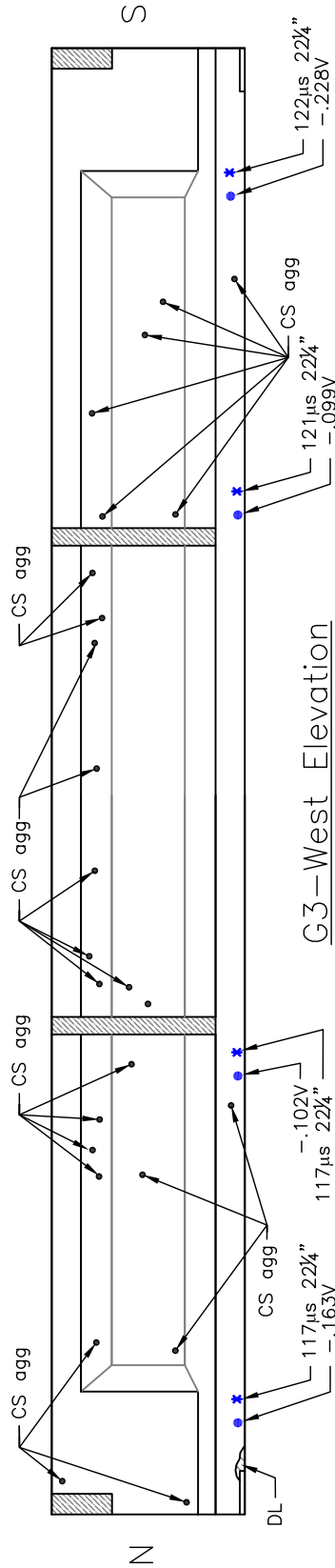
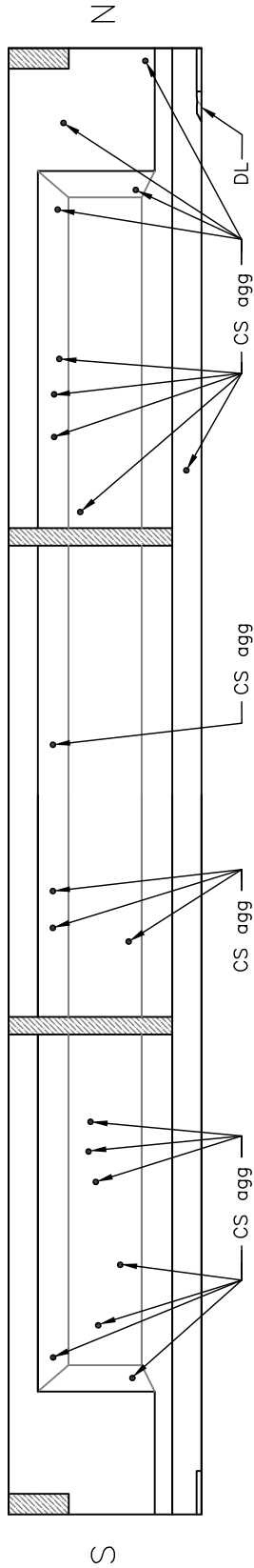

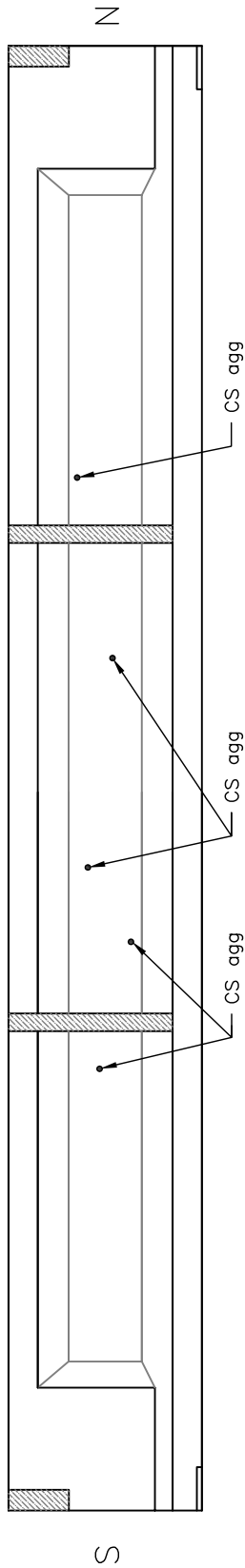

G4--East Elevation

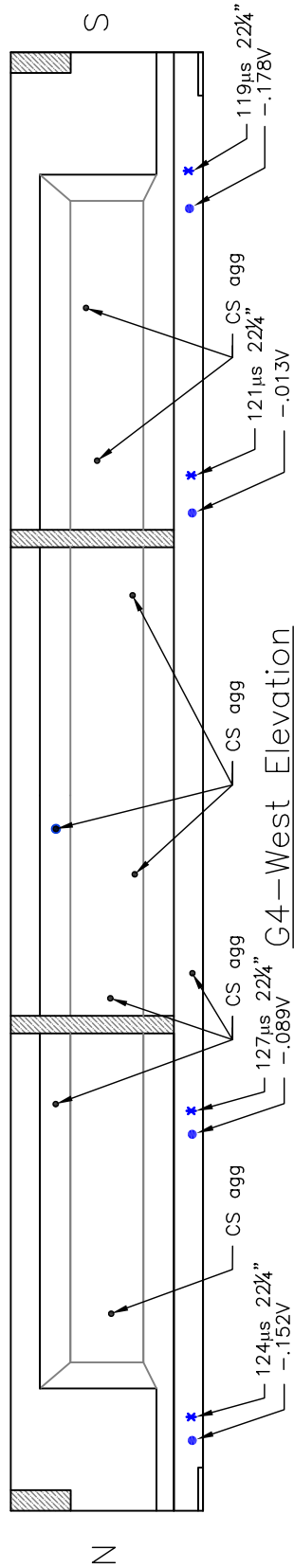

G4--West Elevation



CS AGG, TYP. ALONG LENGTH OF SOFFIT

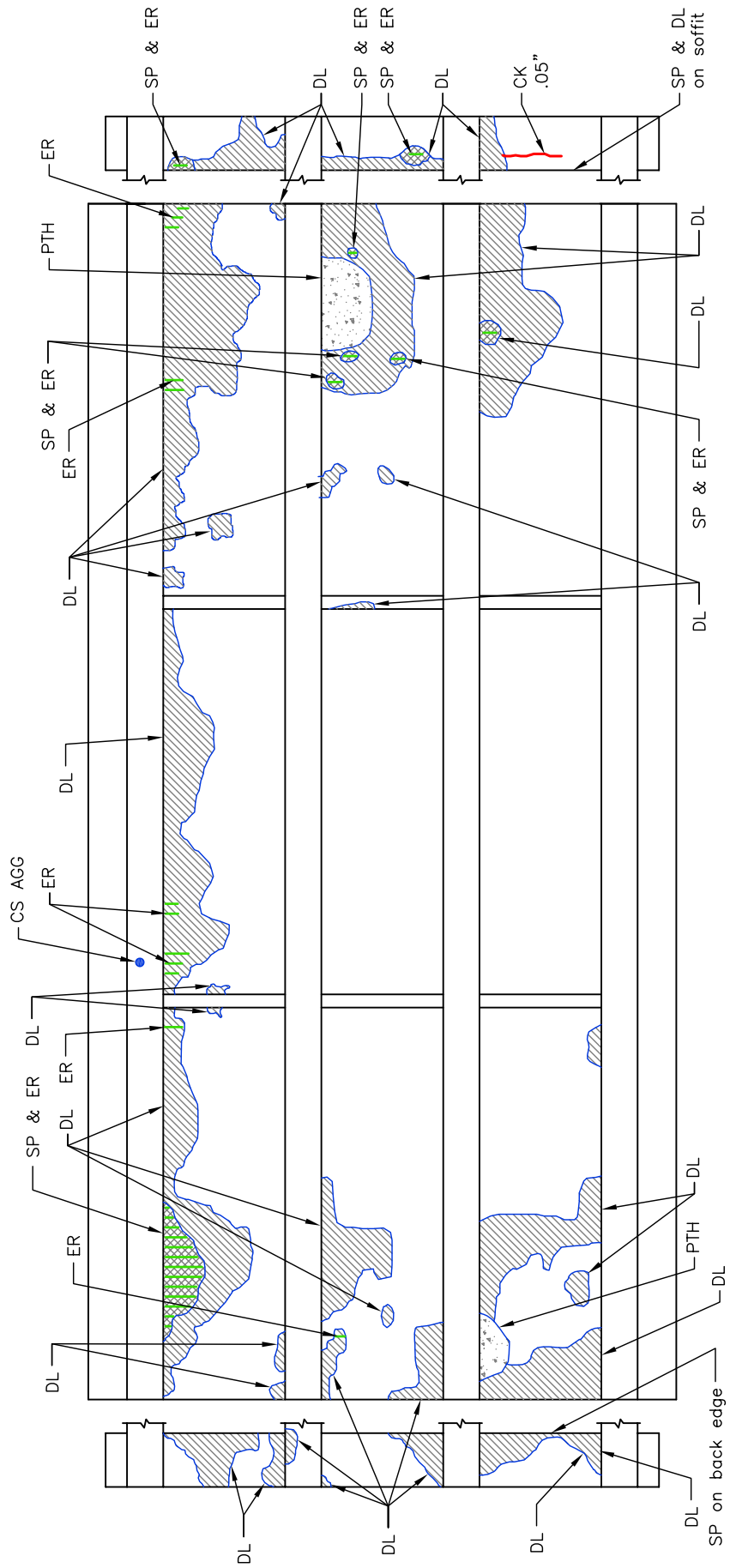

Deck Soffit

North →

← South

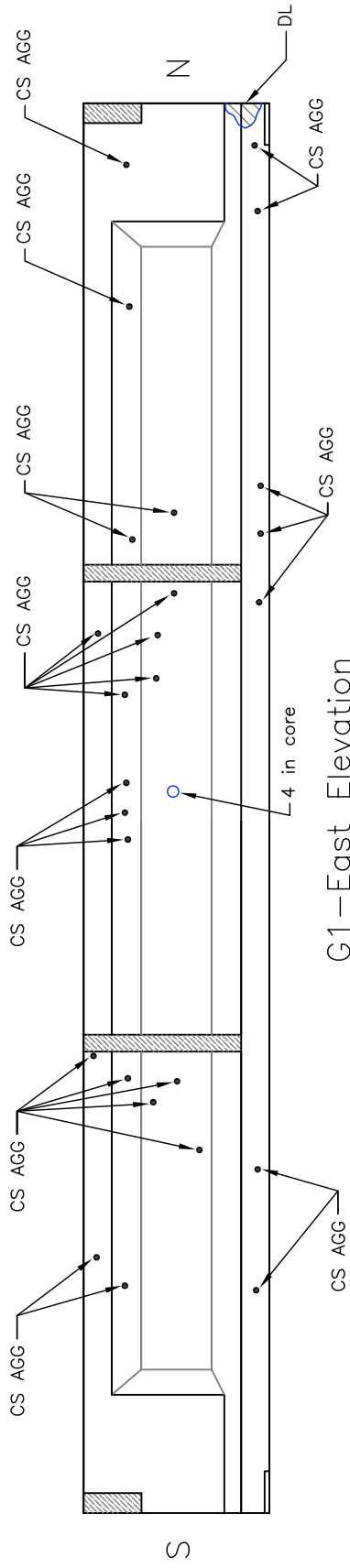

G1—East Elevation

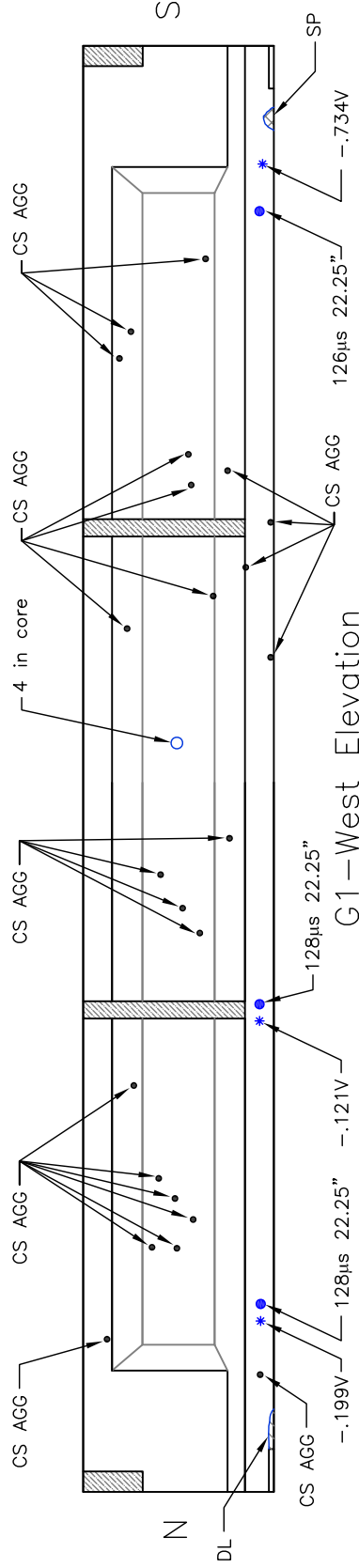

G1—West Elevation

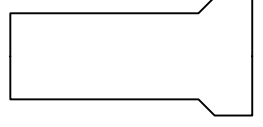

North End

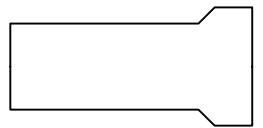

South End

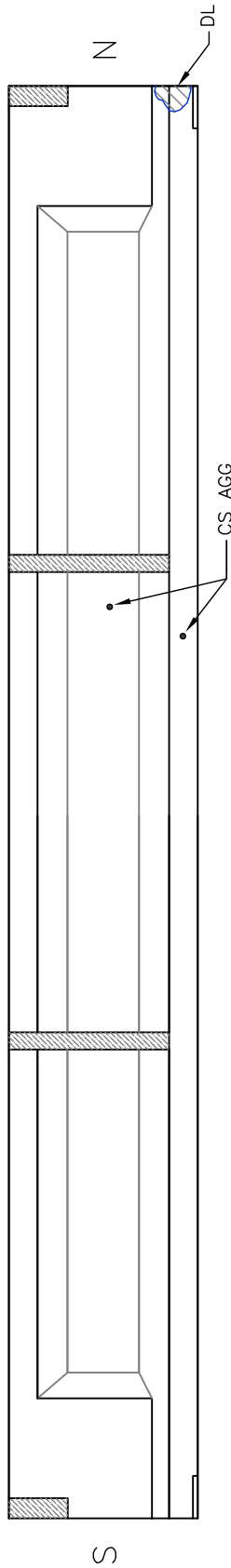

G2--East Elevation

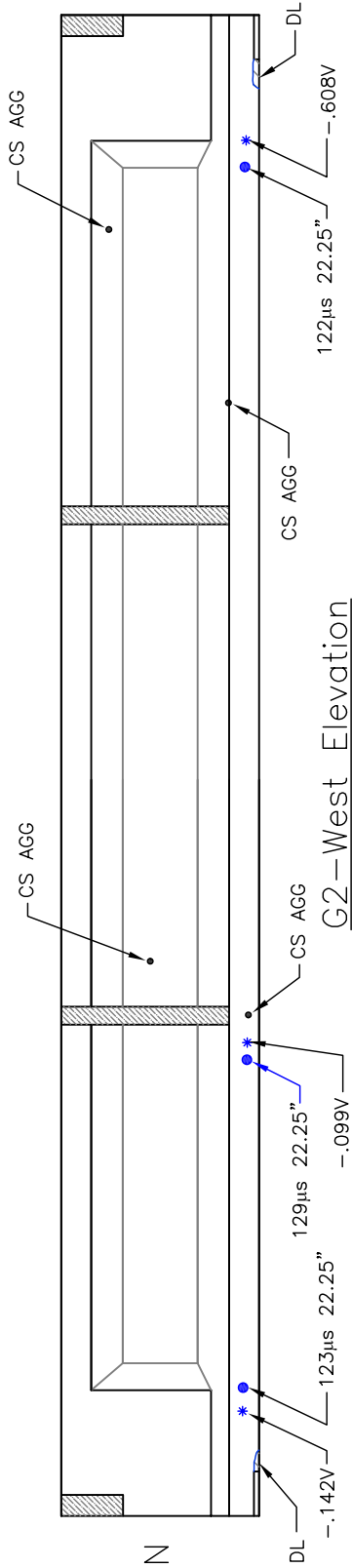

G2--West Elevation

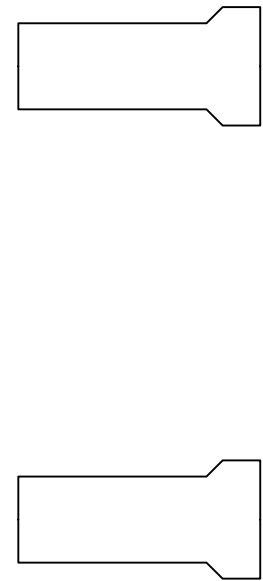

North End

South End

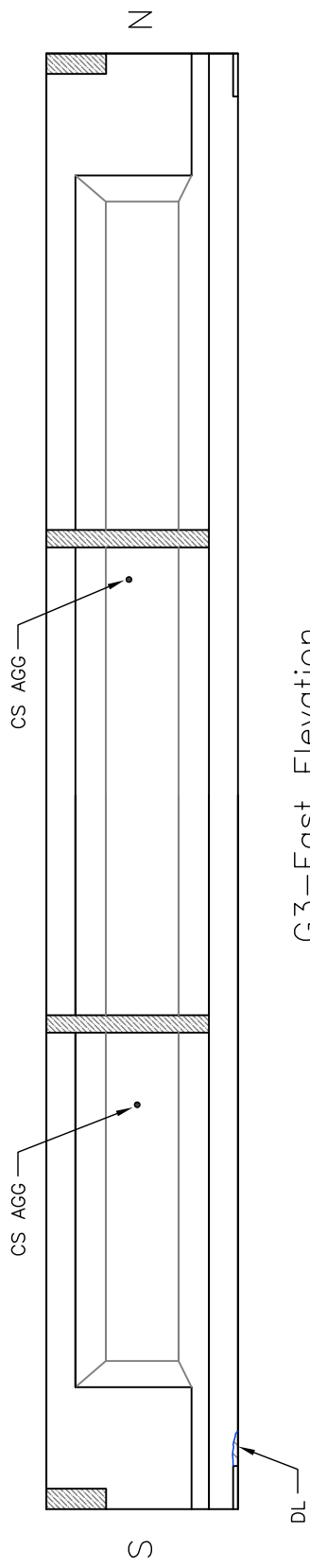

G3—East Elevation

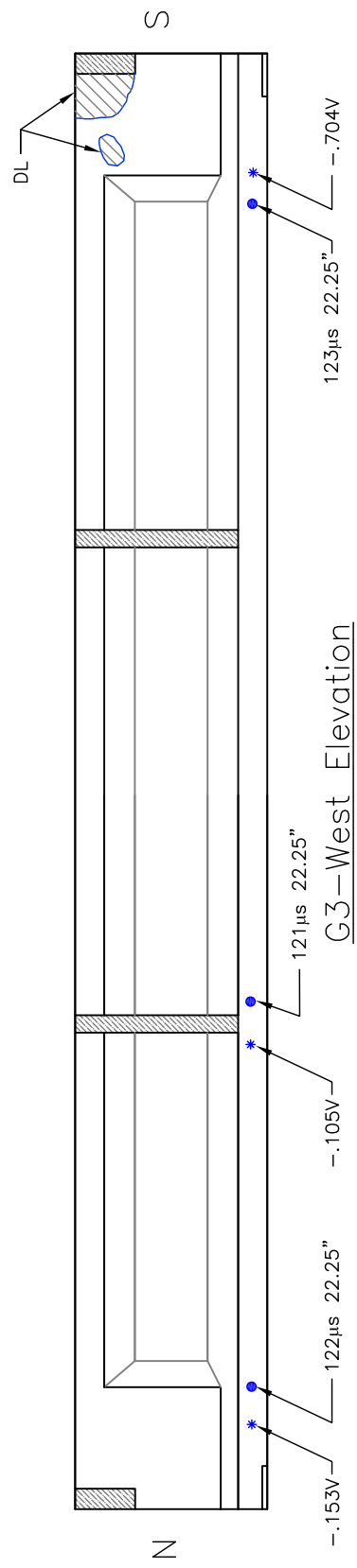

G3—West Elevation

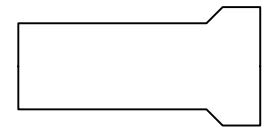

South End

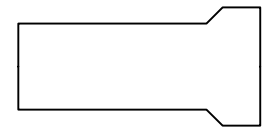

North End

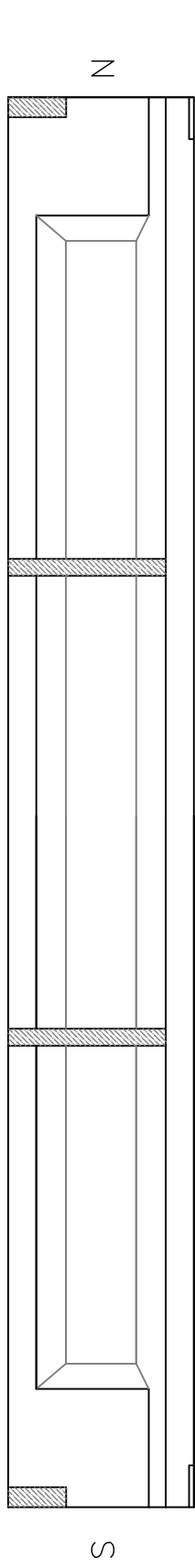

G4--East Elevation

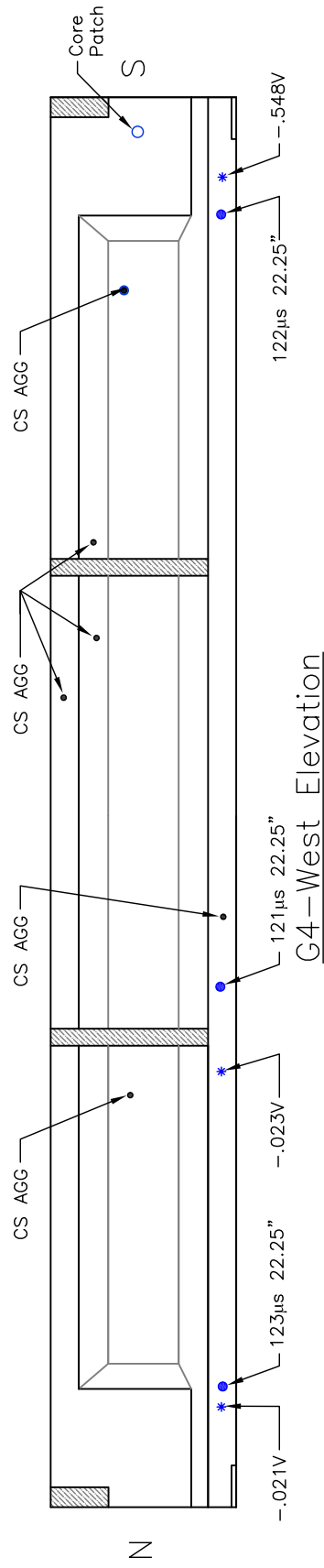

G4--West Elevation



North End

South End

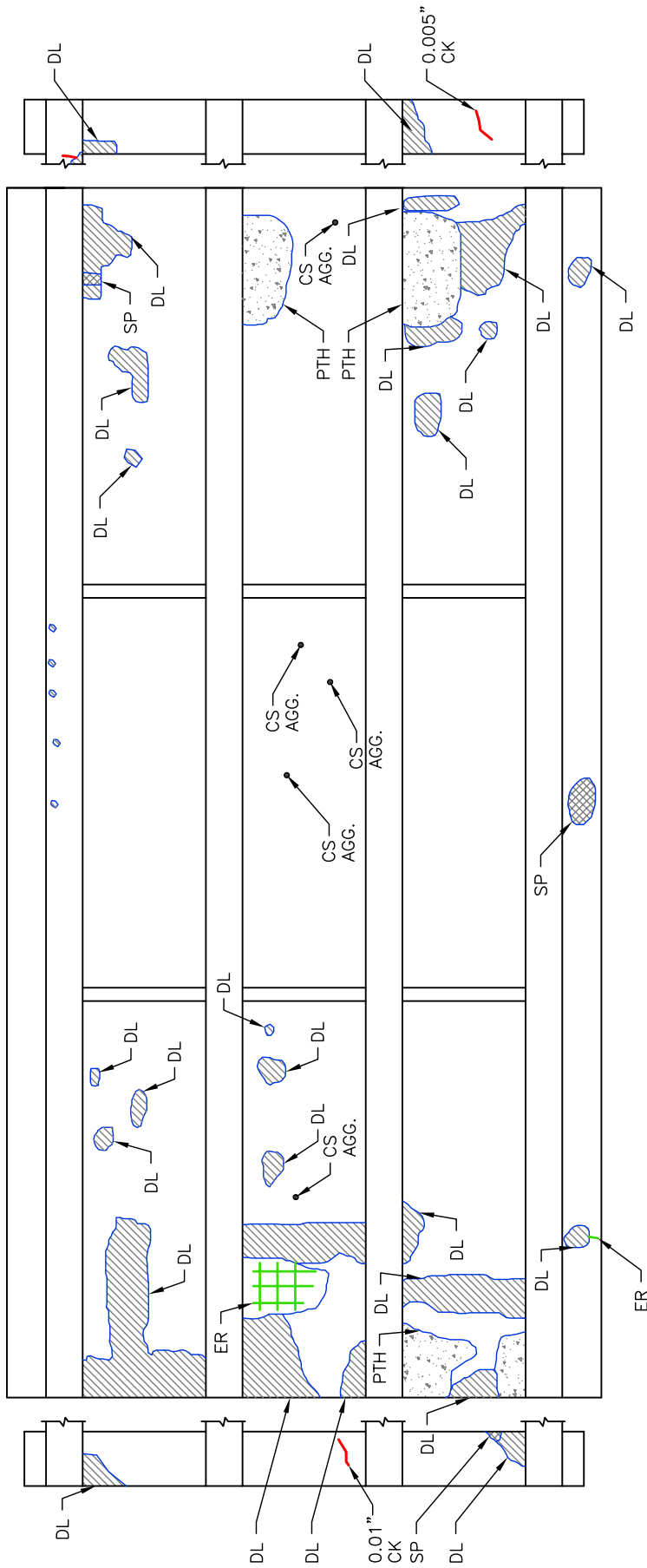

North →

Deck Soffit

← South

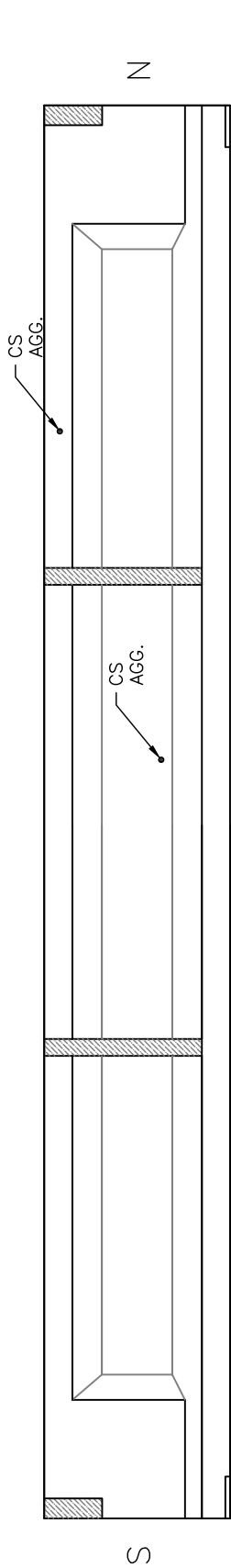

G1—East Elevation

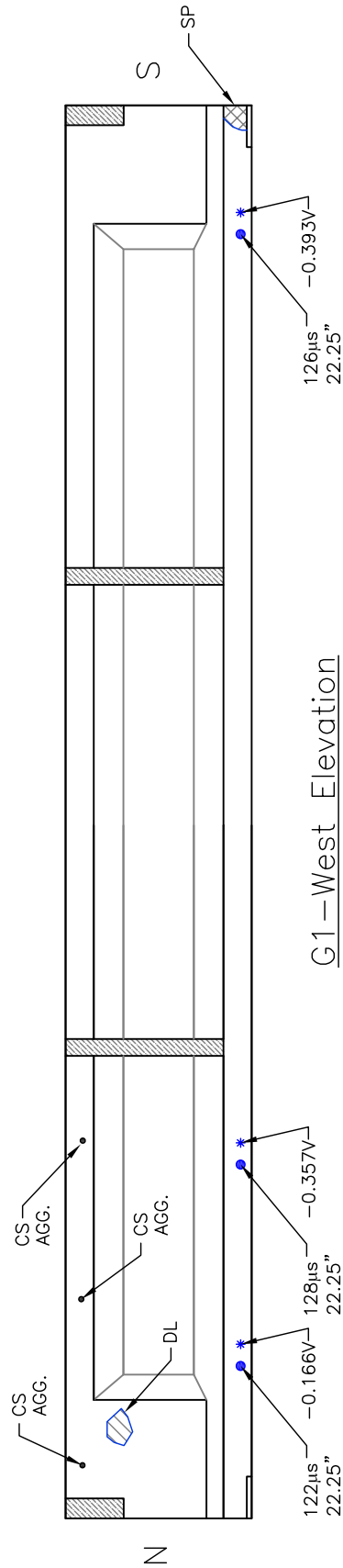

G1—West Elevation



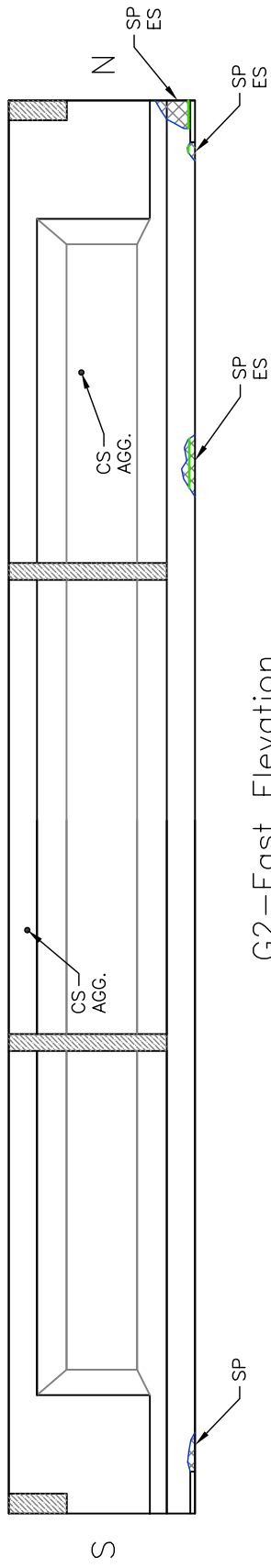

G2—East Elevation

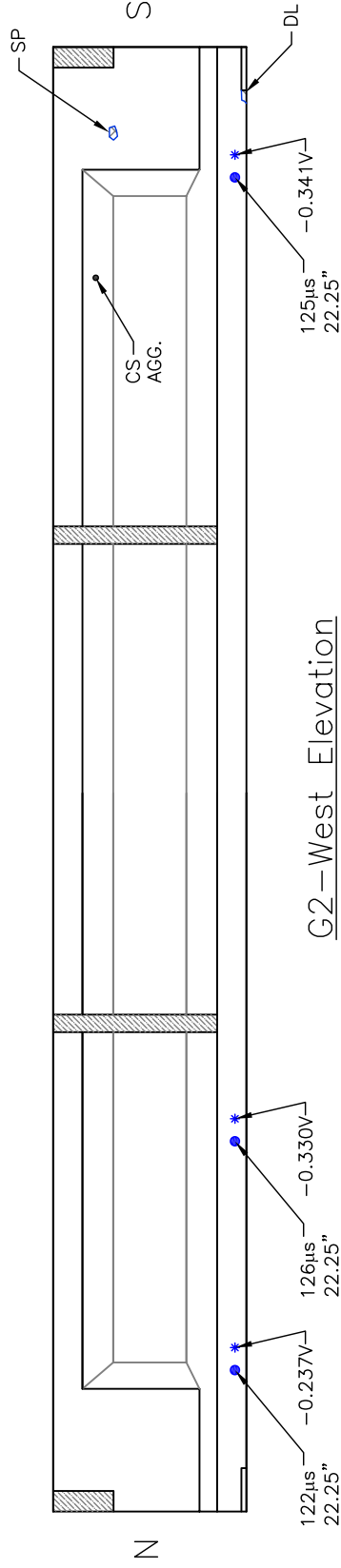

G2—West Elevation

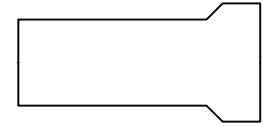

North End

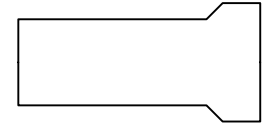

South End

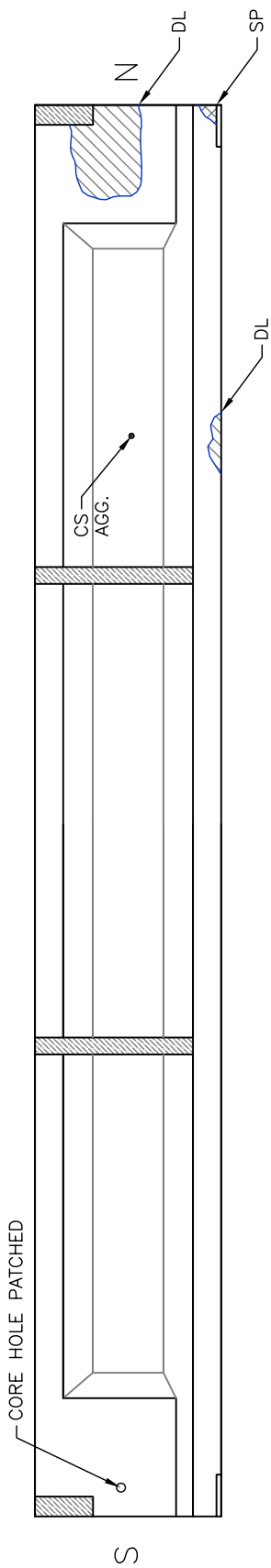

G3—East Elevation

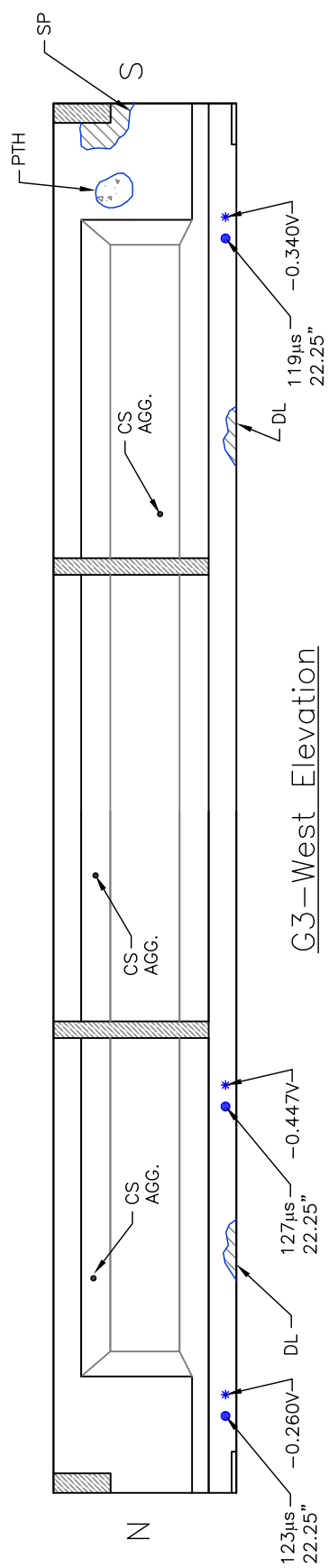

G3—West Elevation



North End

South End

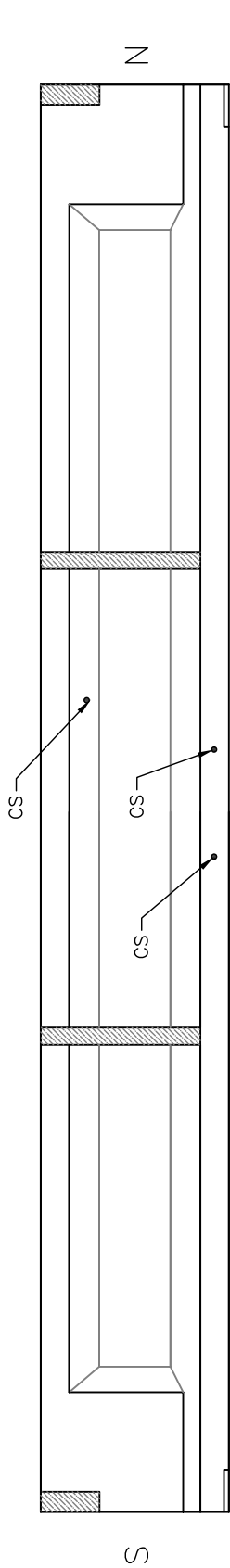

G4--East Elevation

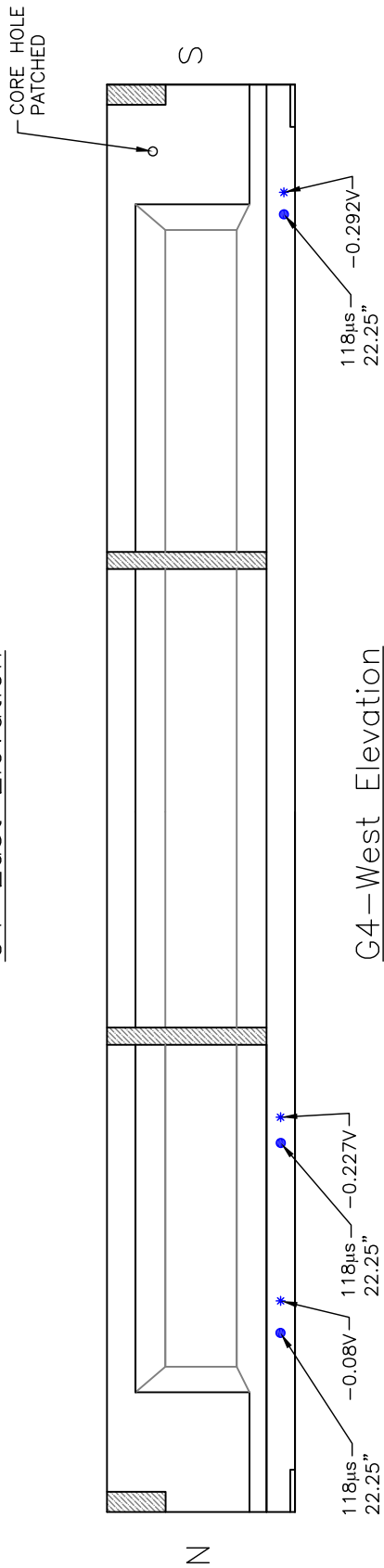

G4--West Elevation



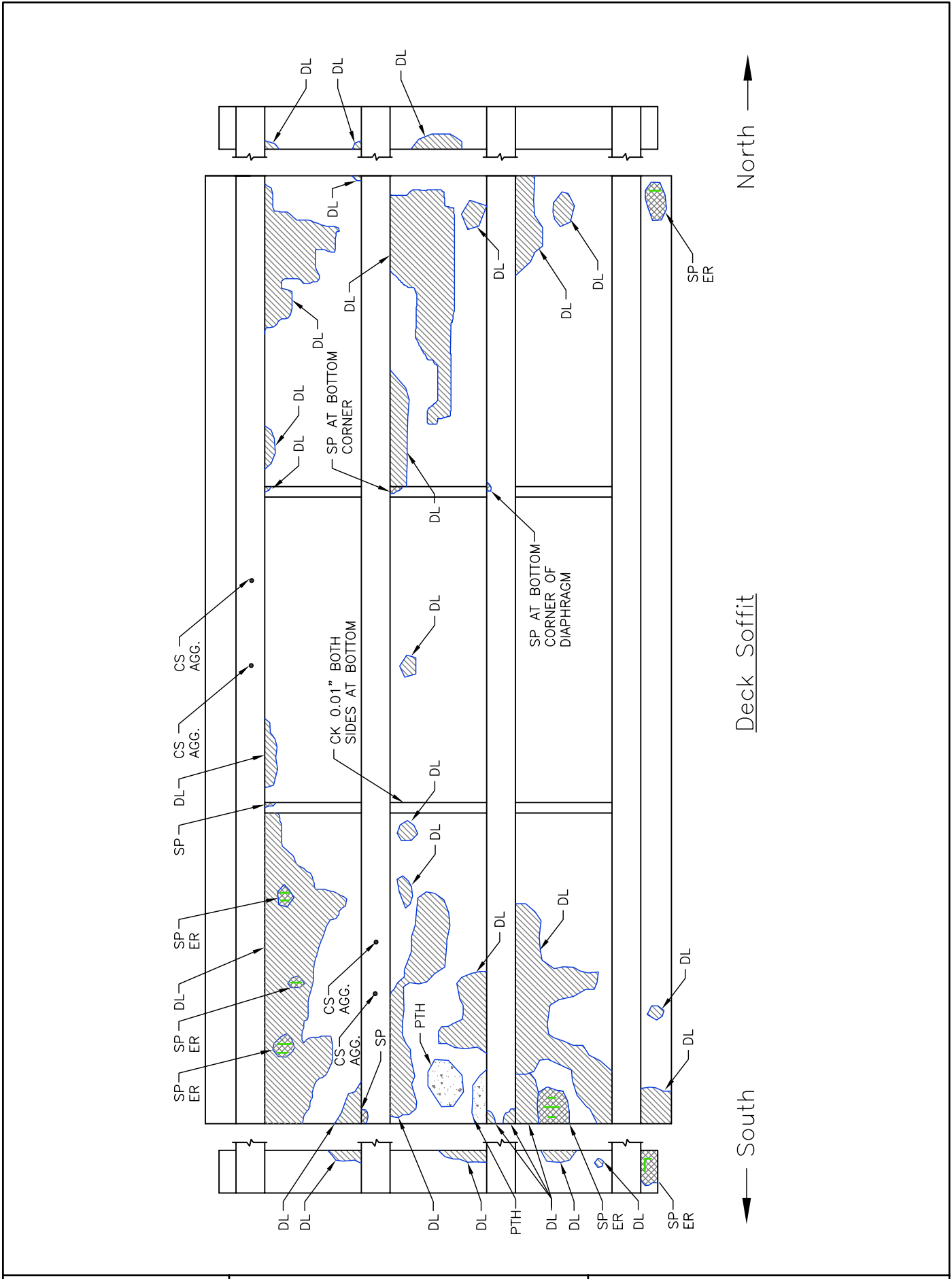

North →

Deck Soffit

← South

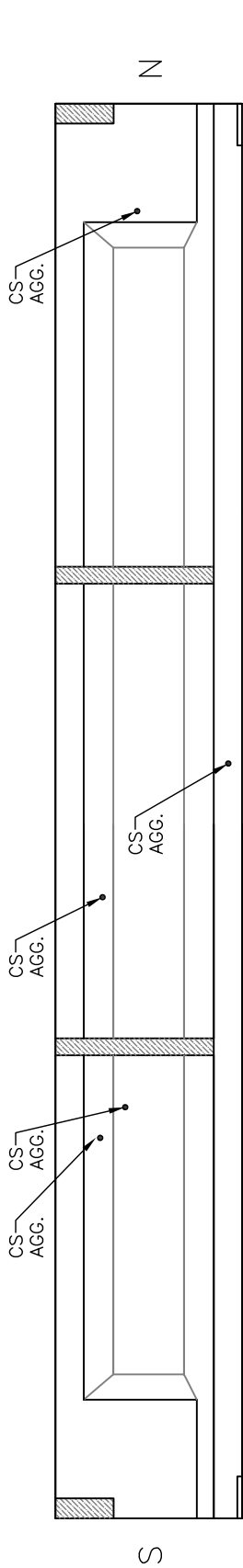

G1—East Elevation

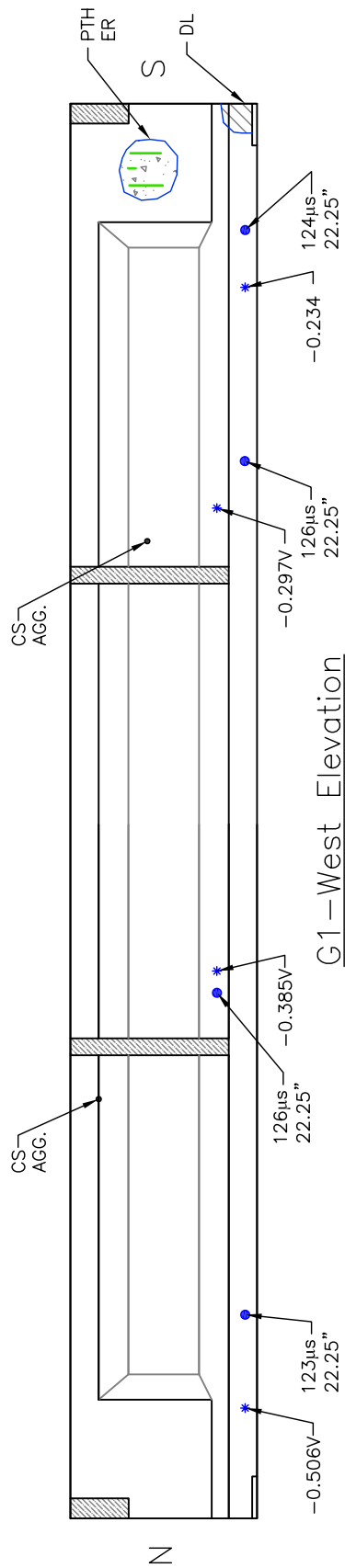

G1—West Elevation



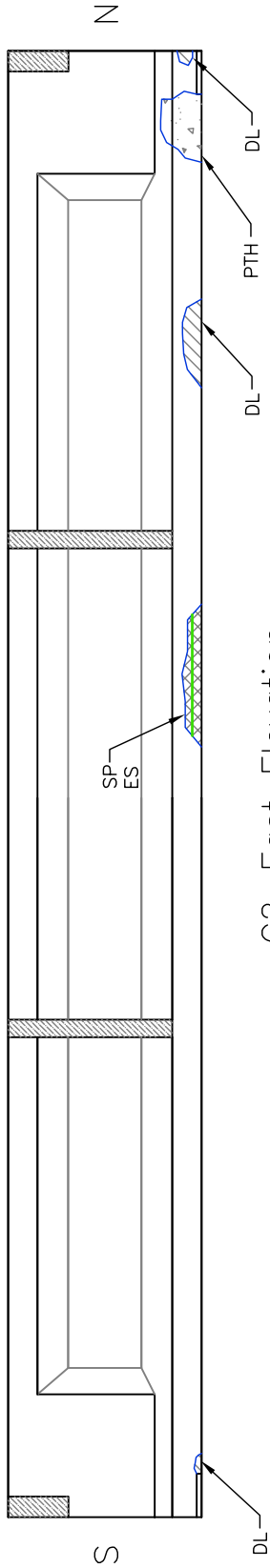

G2--East Elevation

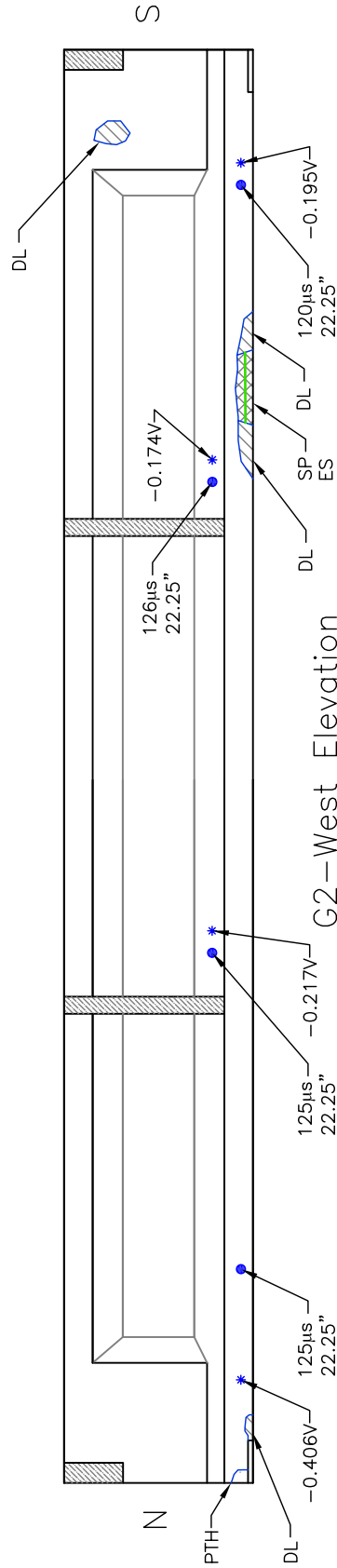

G2--West Elevation

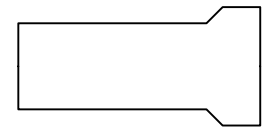

South End

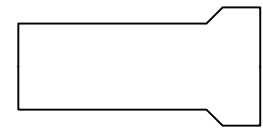

North End

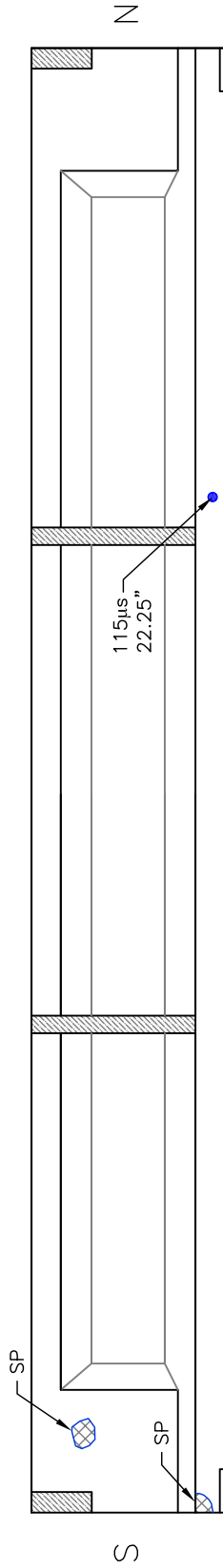

G3—East Elevation

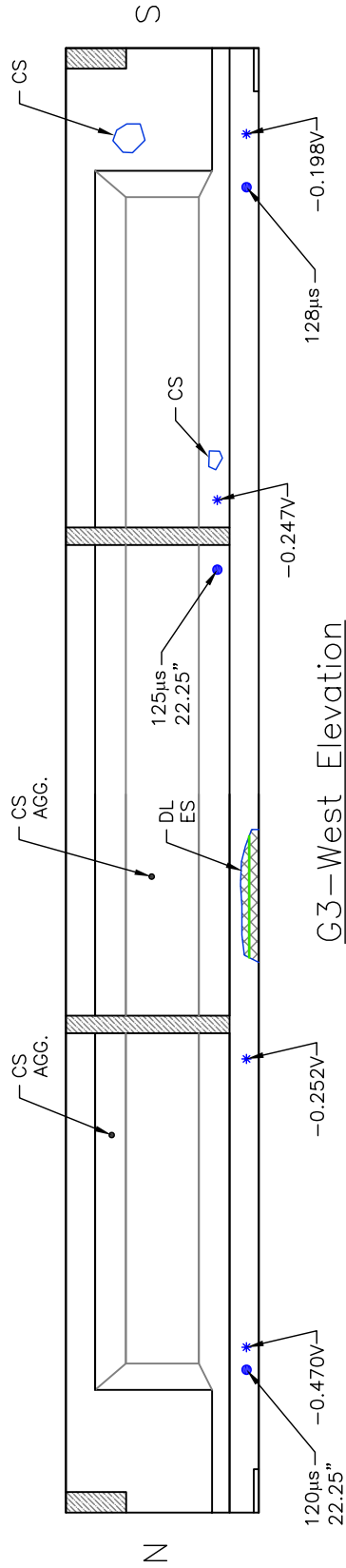

G3—West Elevation



North End

South End

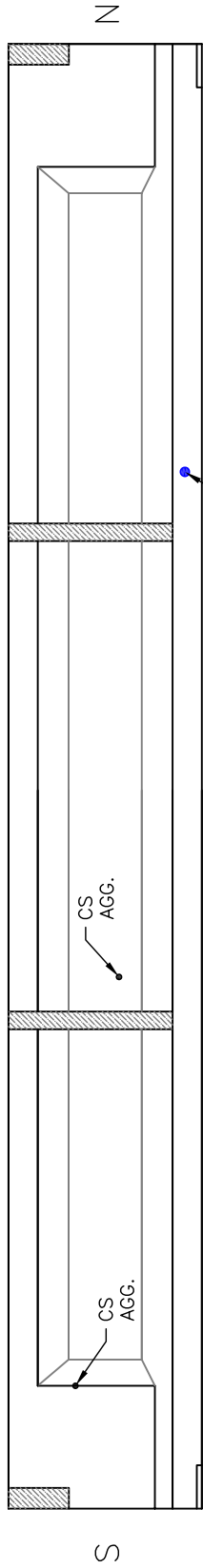

G4—East Elevation

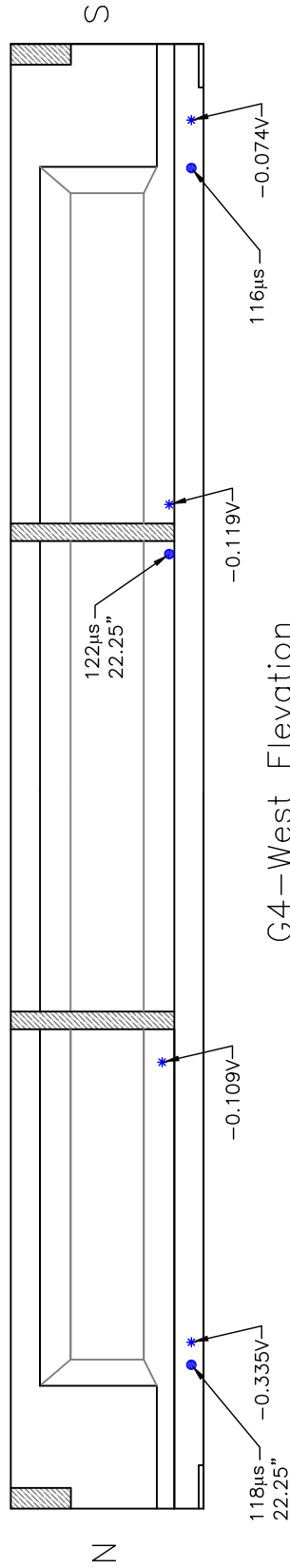

G4—West Elevation



North End

South End

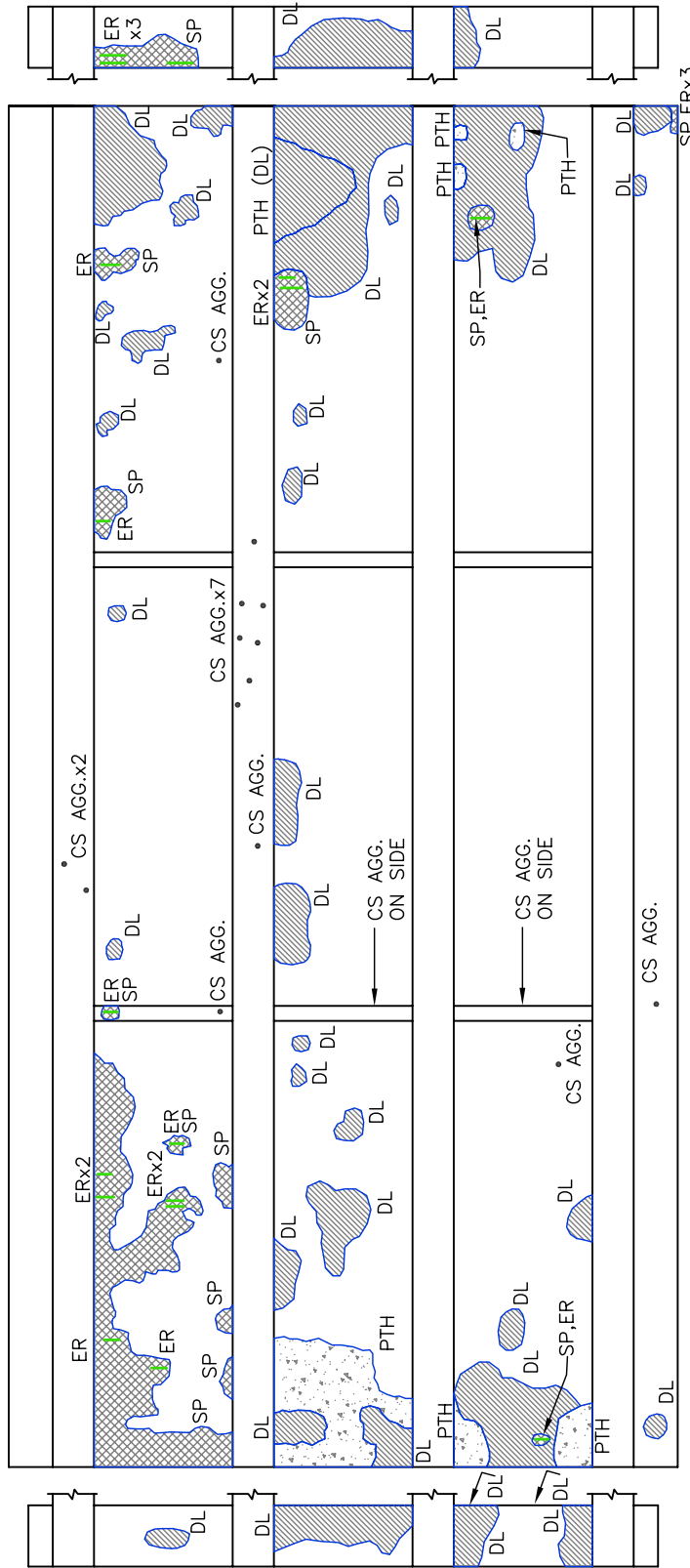

North →

Deck Soffit

← South

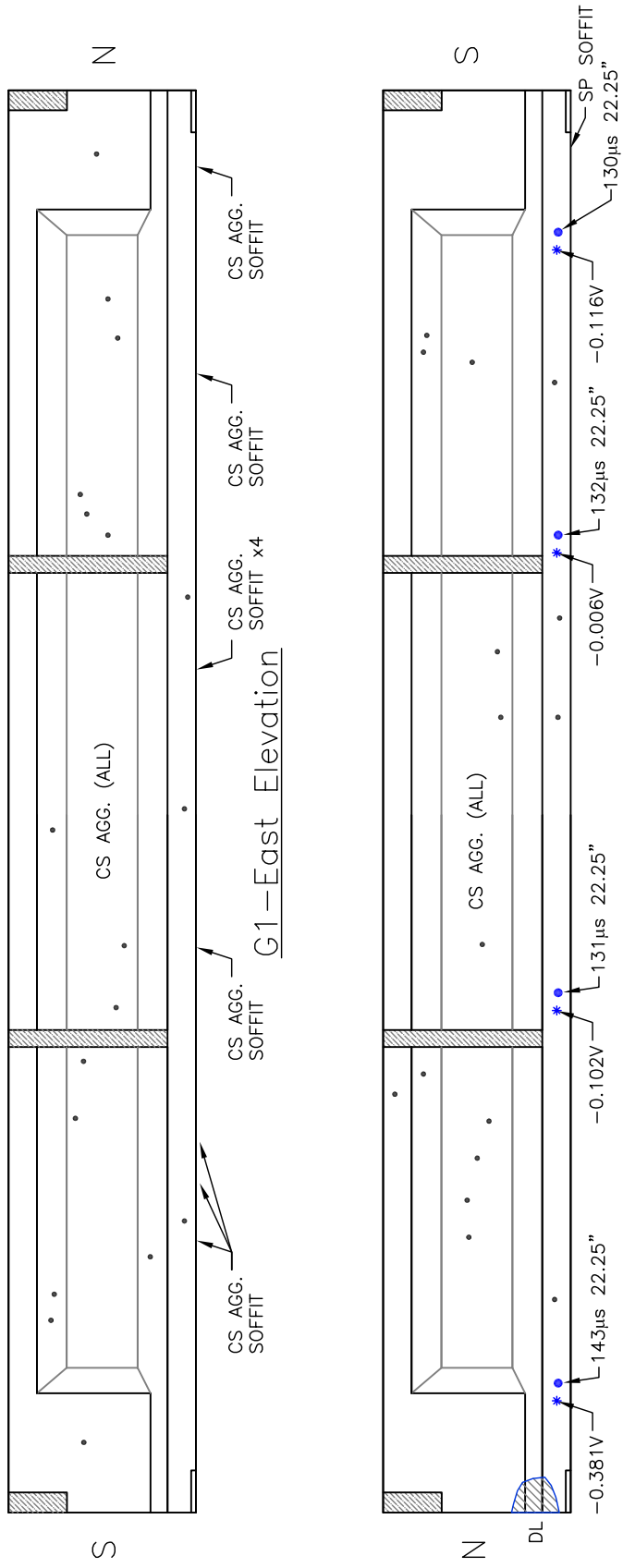

G1—East Elevation

G1—West Elevation

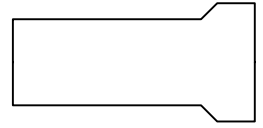
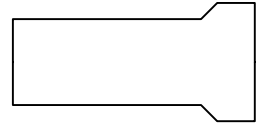

North End

South End

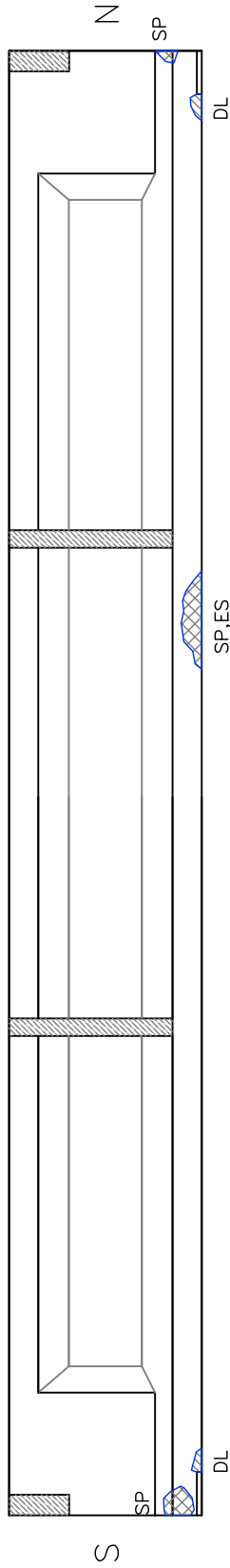

G2—East Elevation

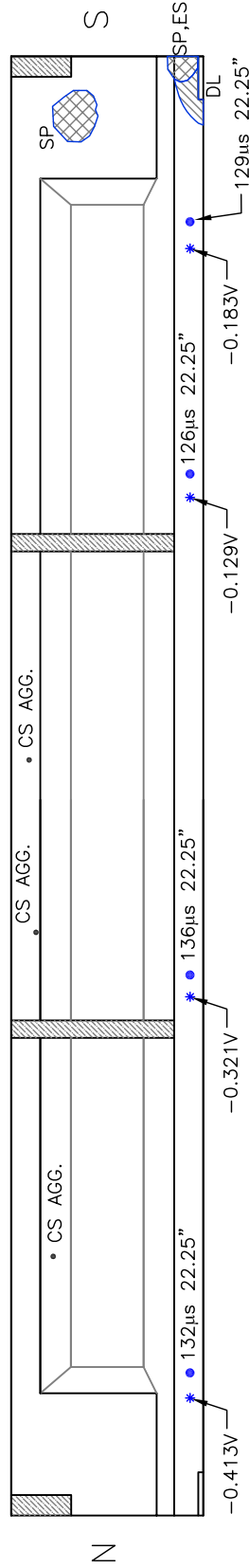

G2—West Elevation

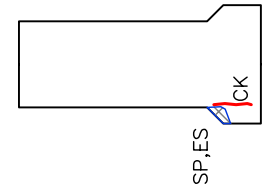

South End

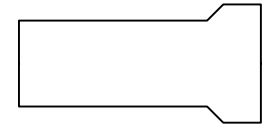

North End

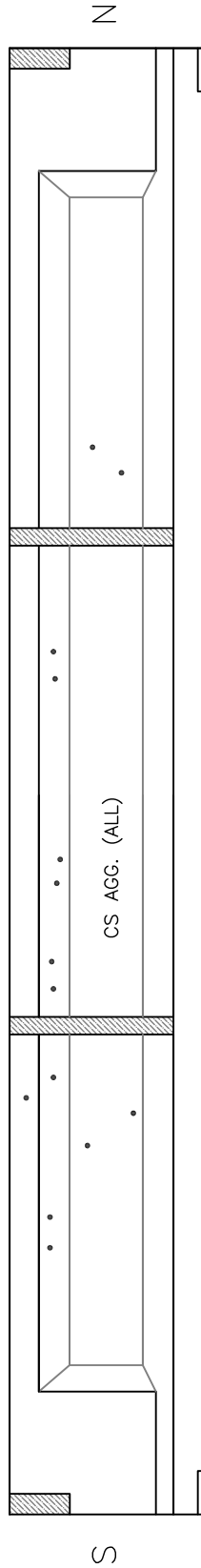

G3—East Elevation

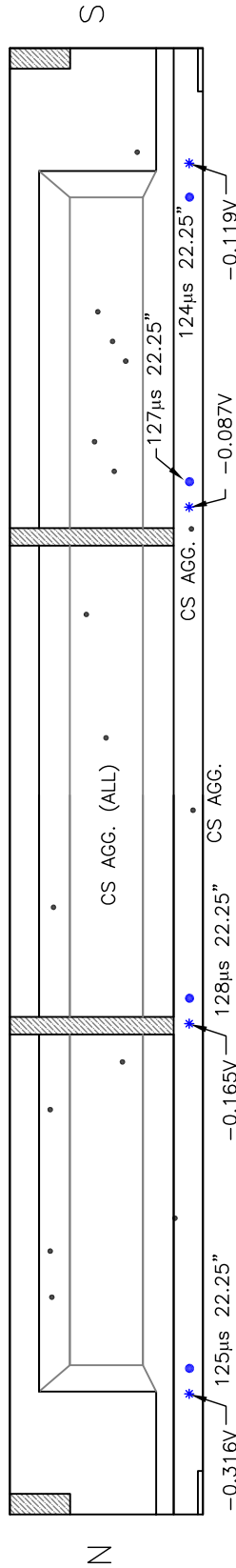

G3—West Elevation



North End

South End

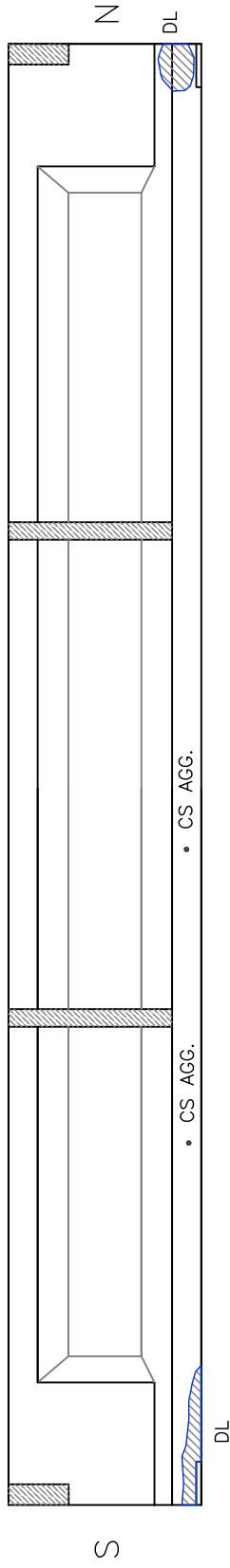

G4--East Elevation

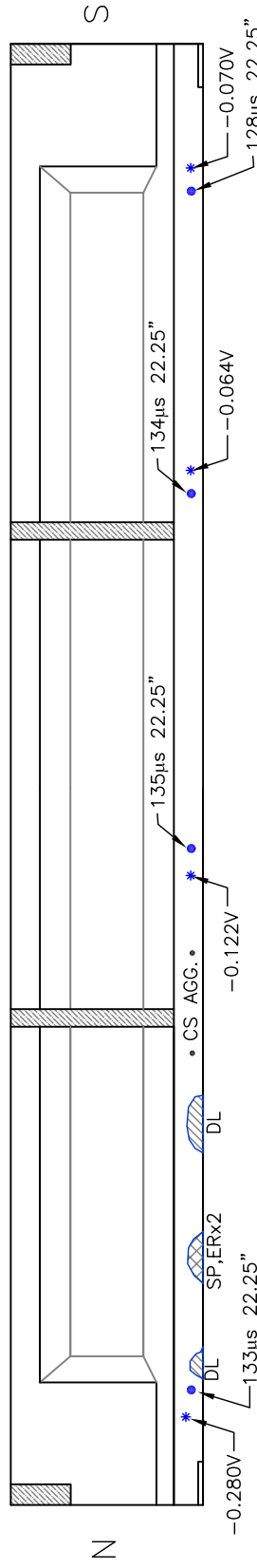

G4--West Elevation

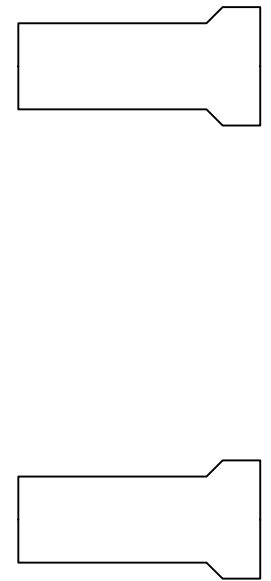

North End

South End

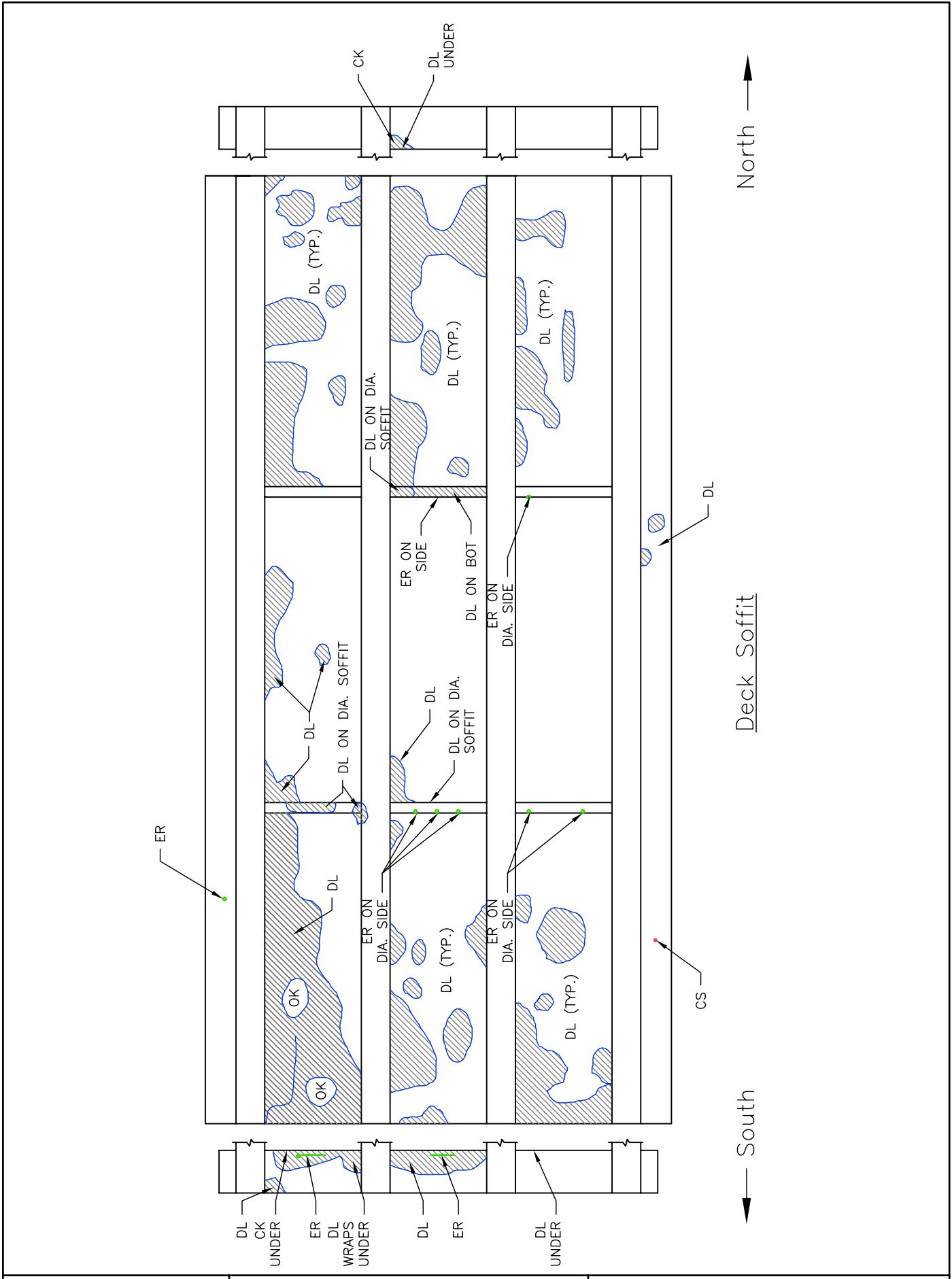

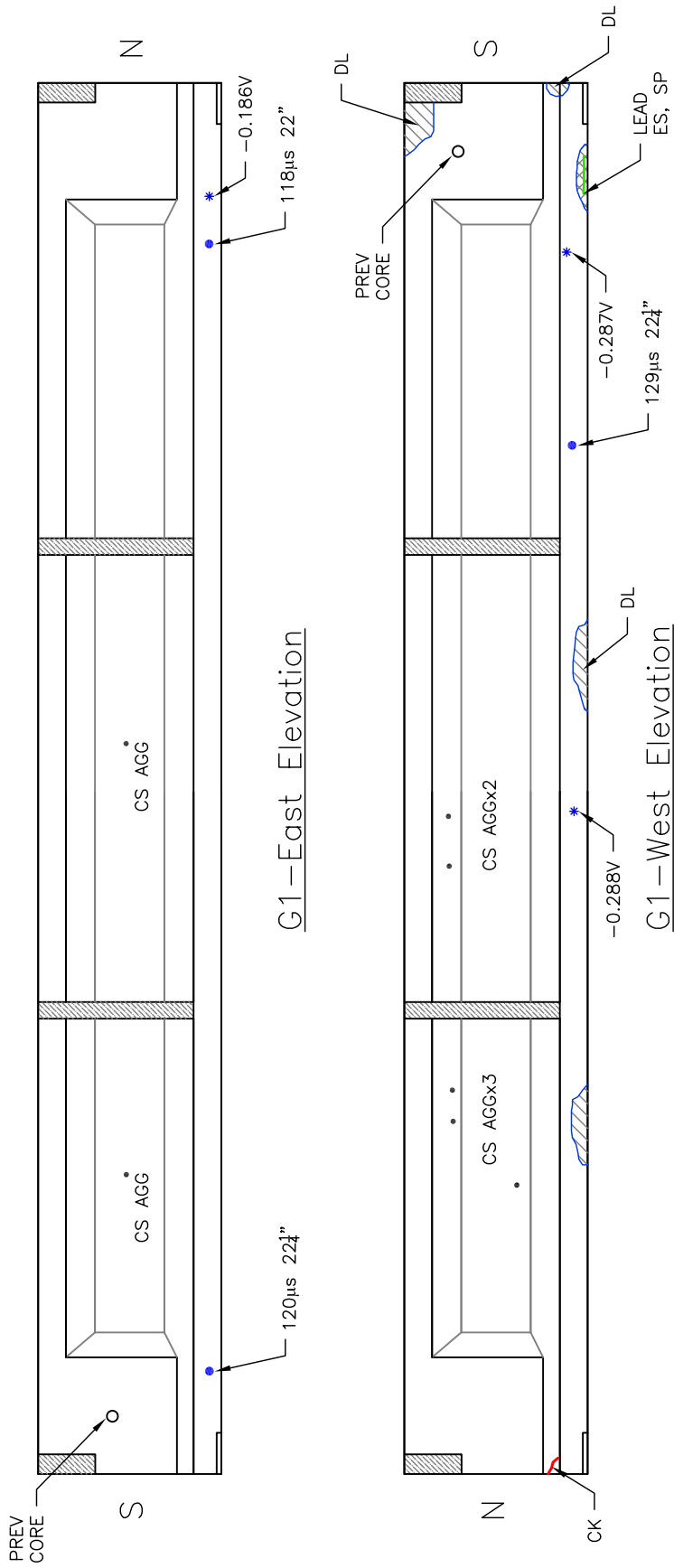

G1—East Elevation

G1—West Elevation



North End

South End

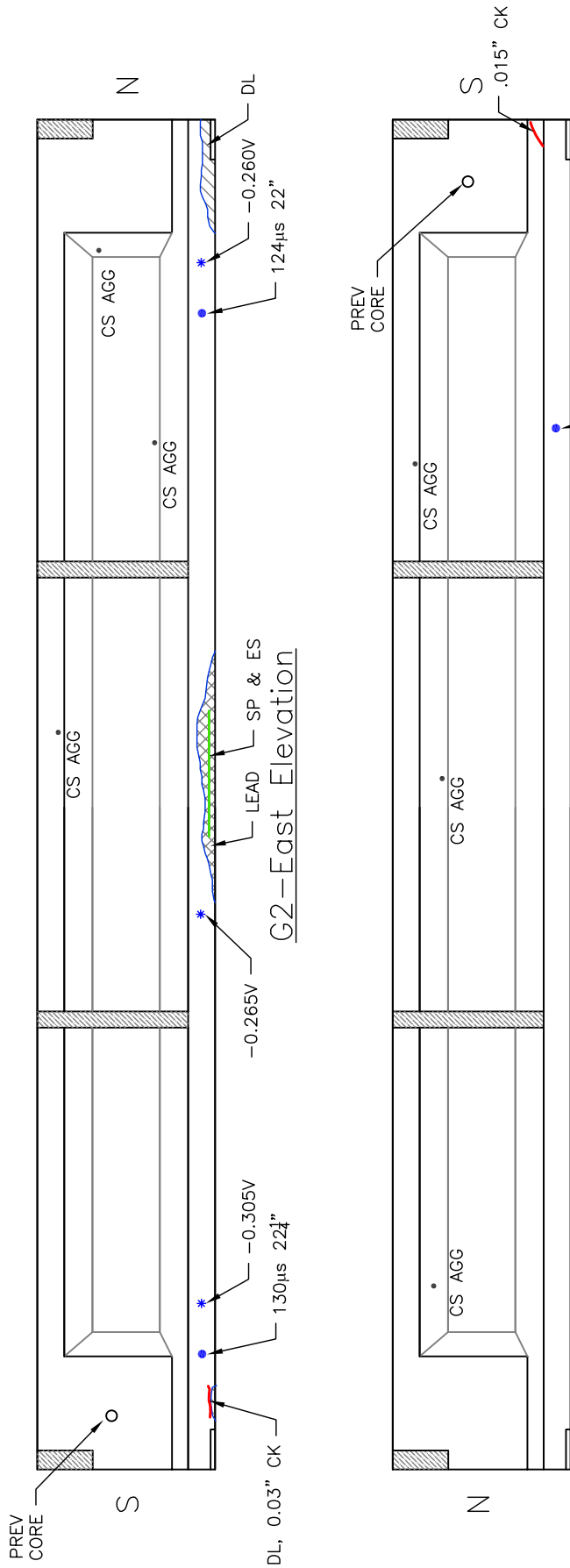

G2—East Elevation

G2—West Elevation



North End

South End

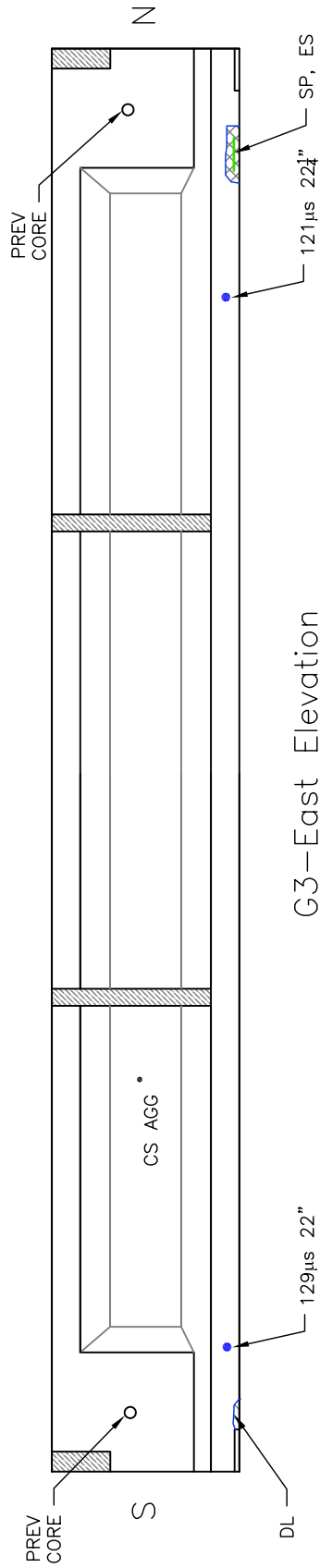

G3—East Elevation

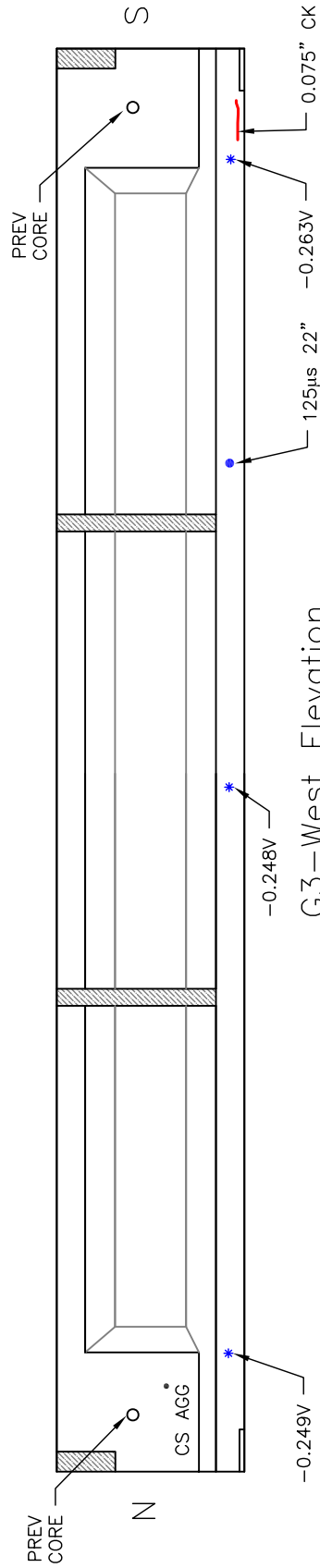

G3—West Elevation



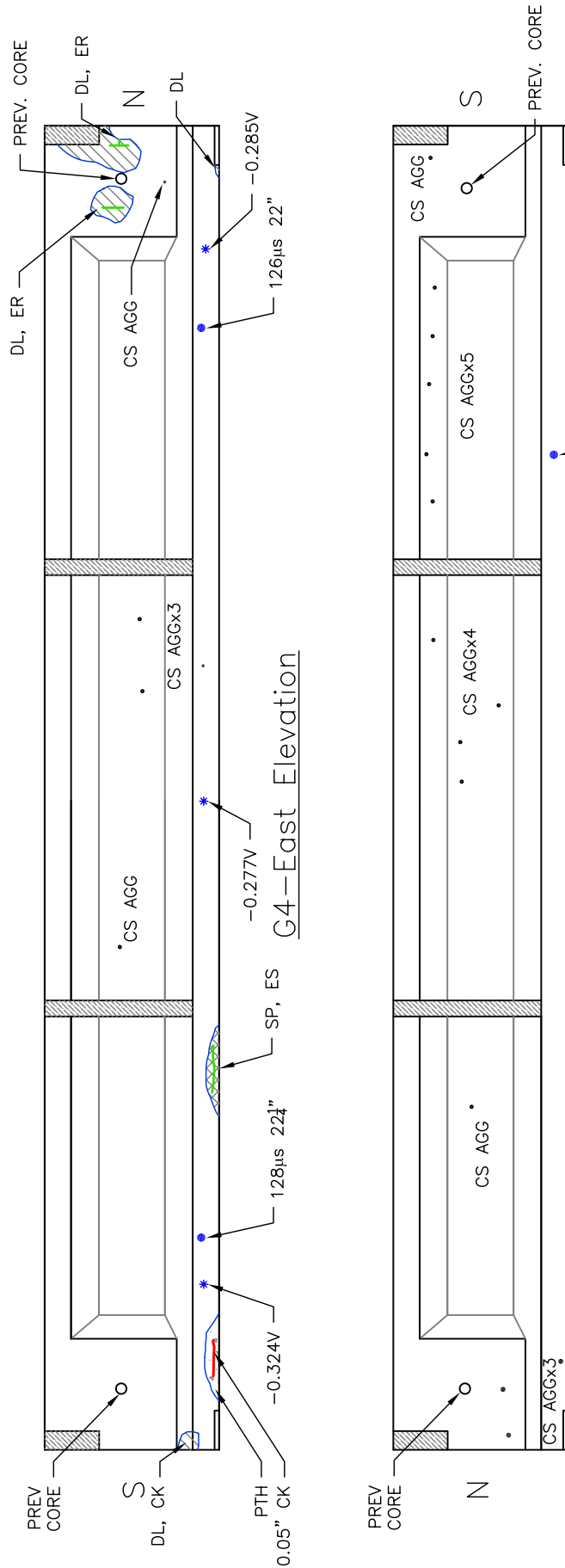

G4—West Elevation



North End

South End

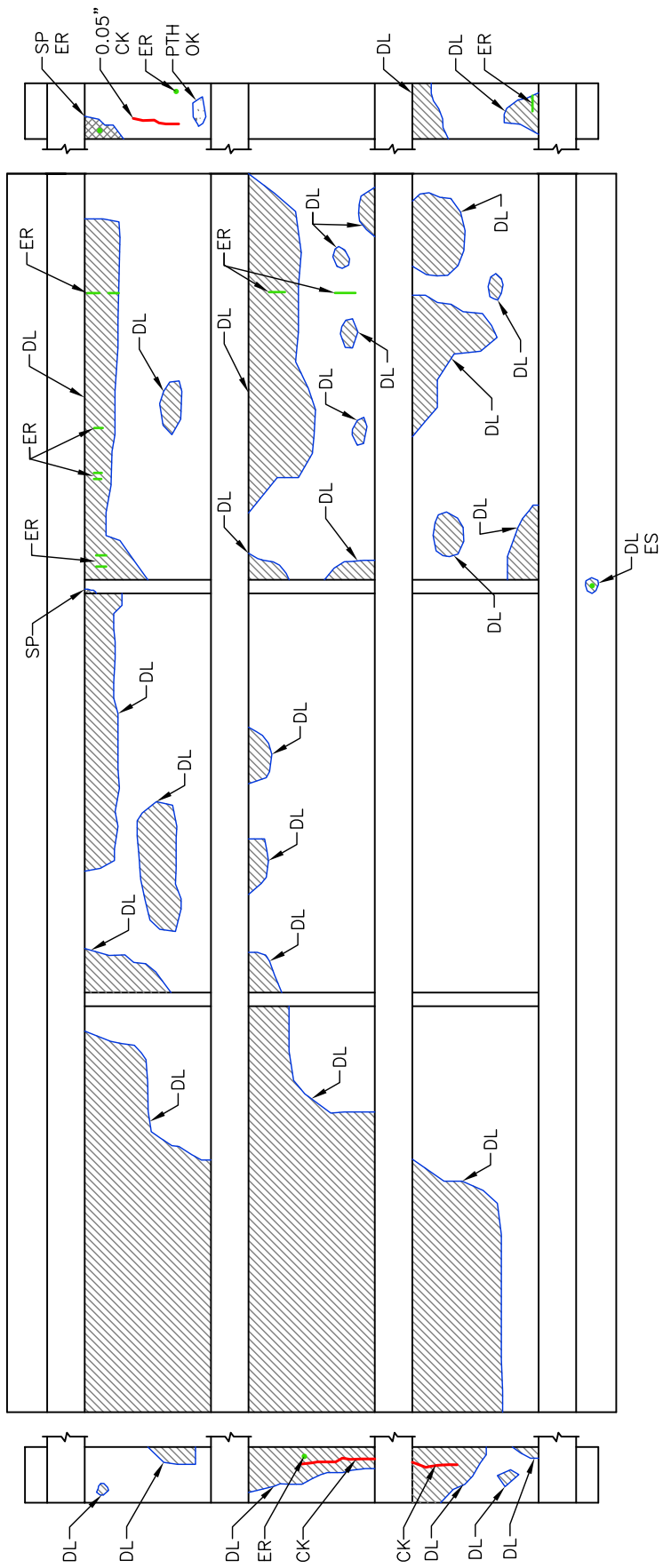

North →

Deck Soffit

← South

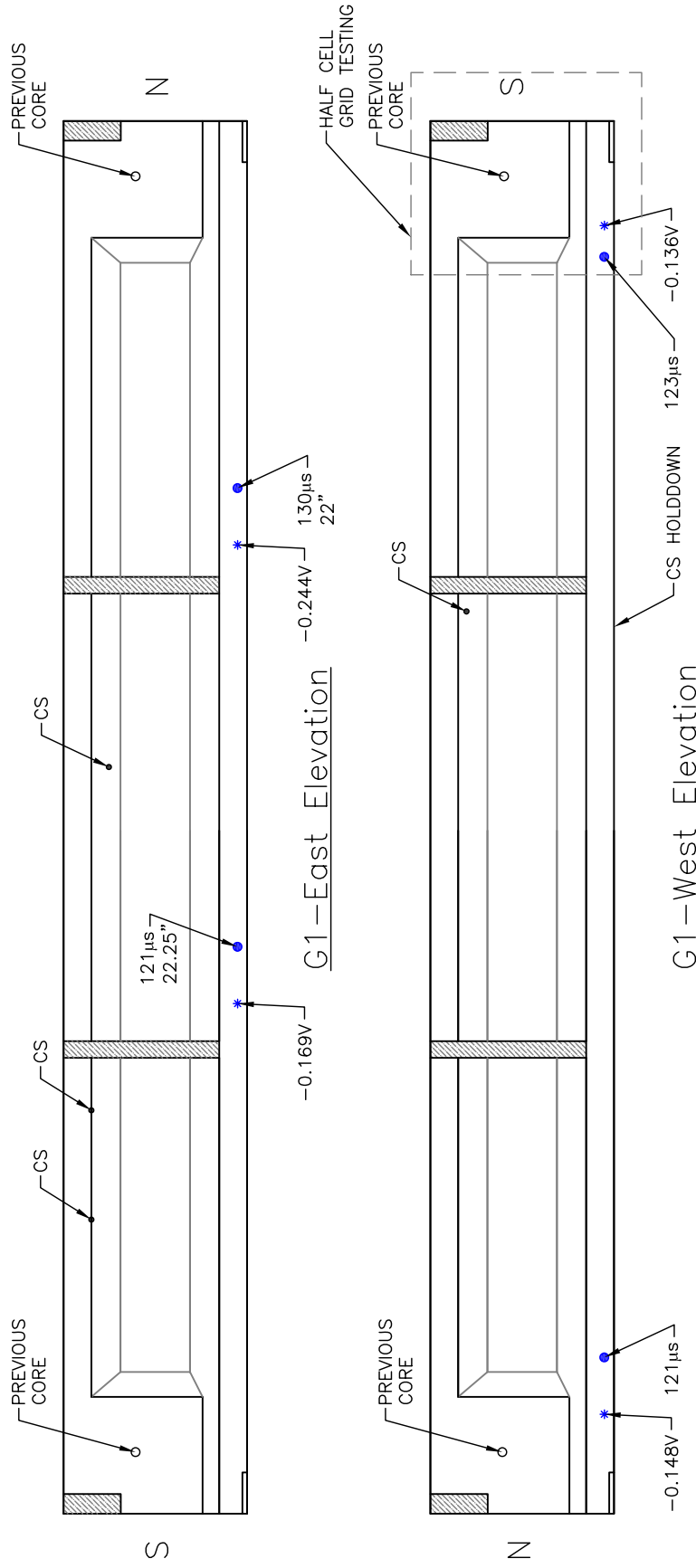

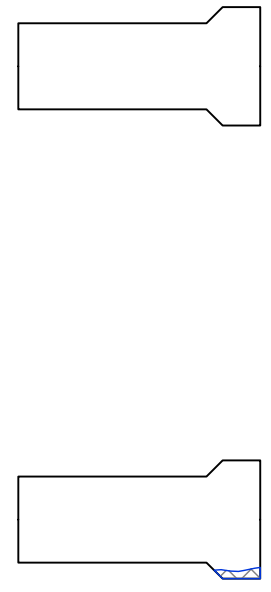
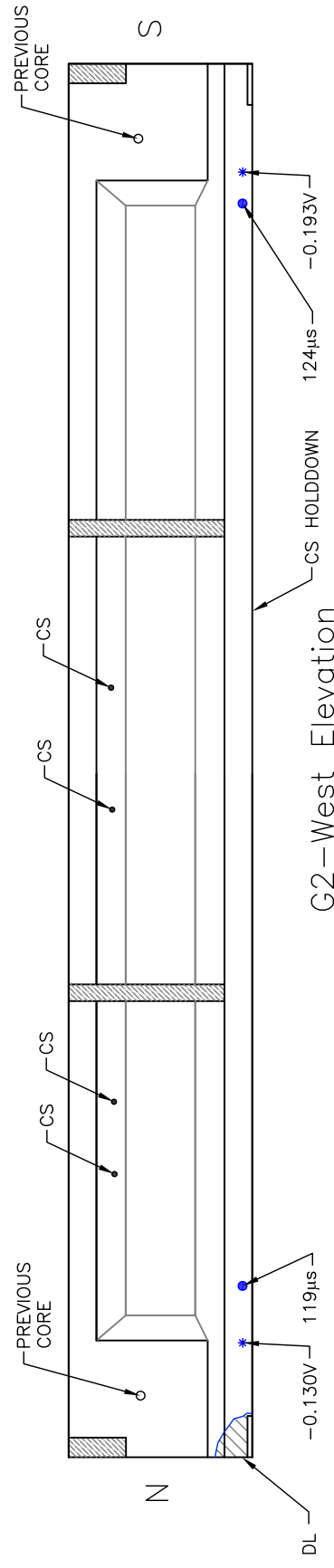
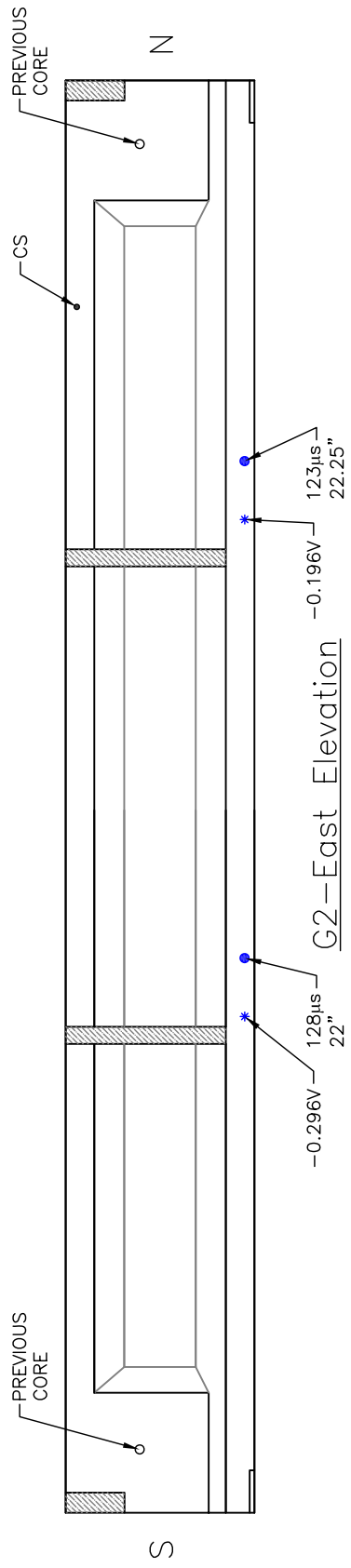

North End South End

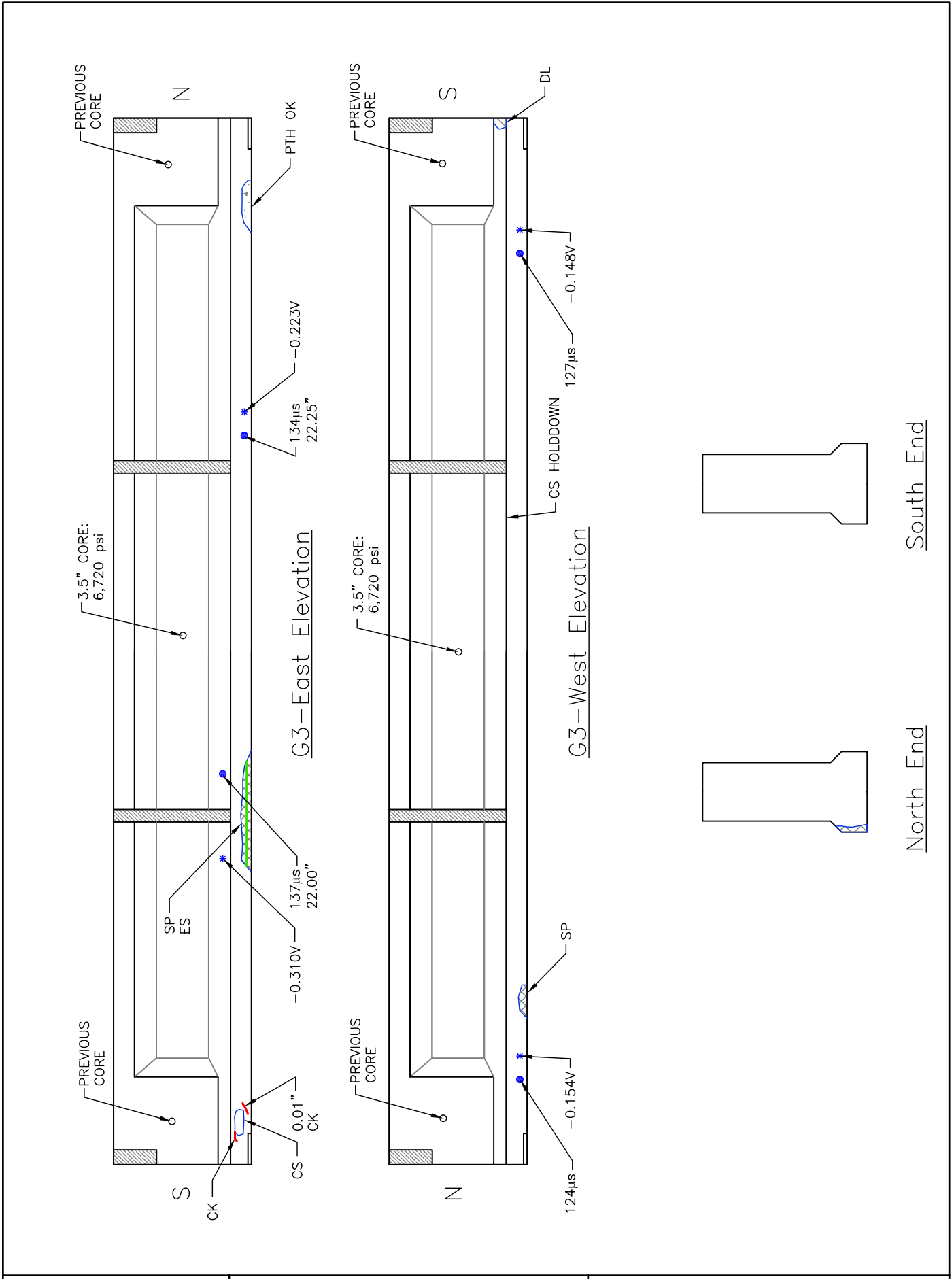

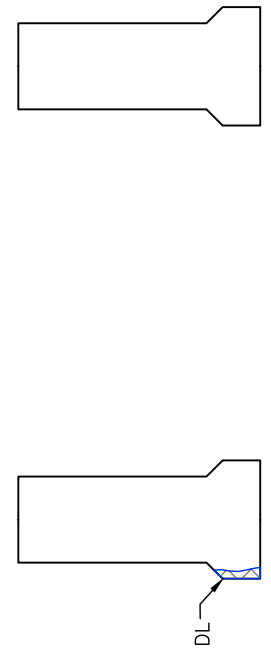
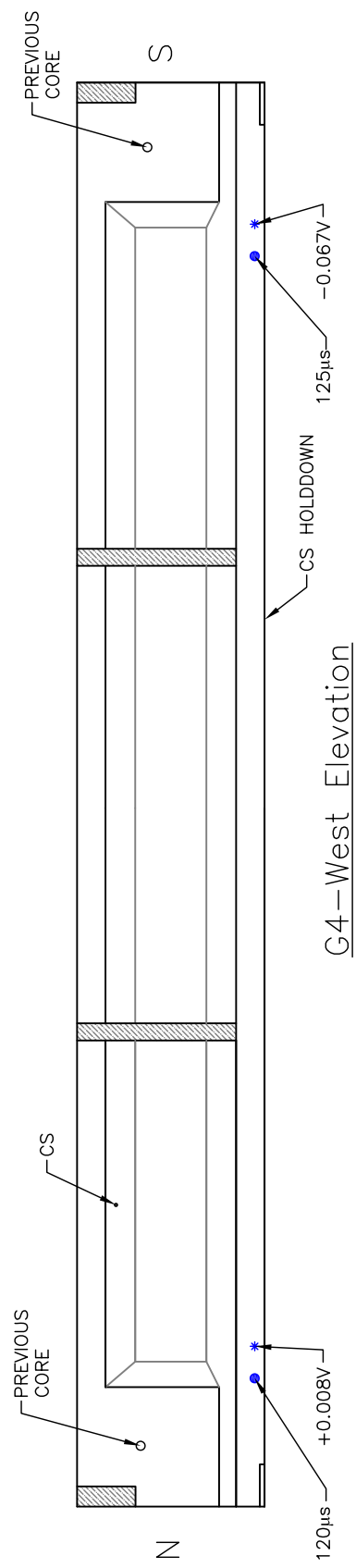
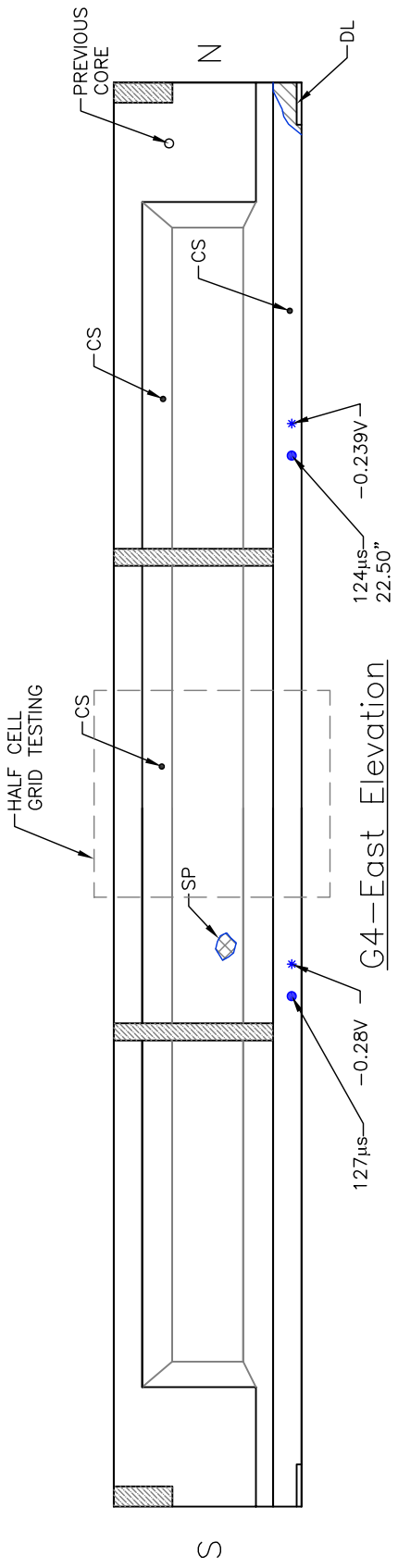

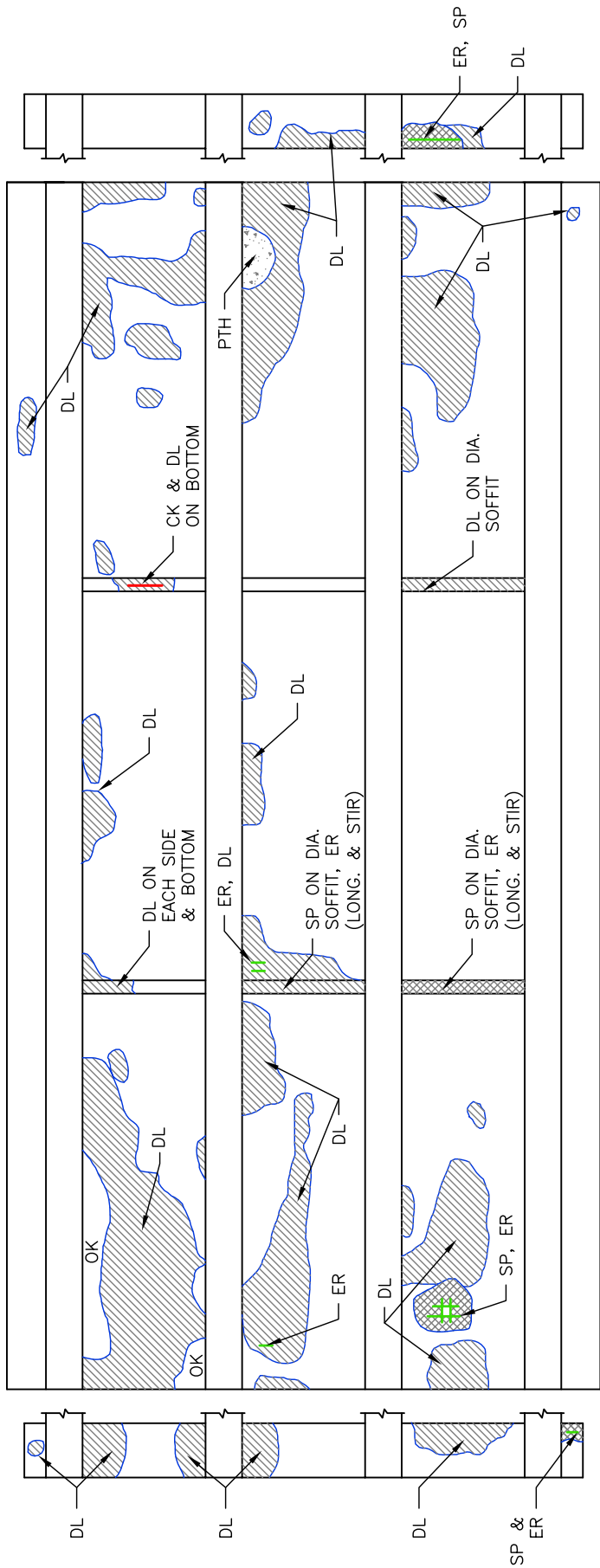

North →

Deck Soffit

← South

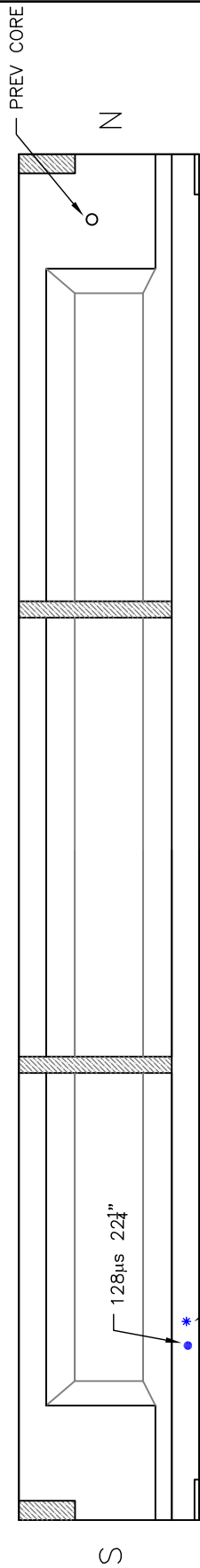

G1—East Elevation

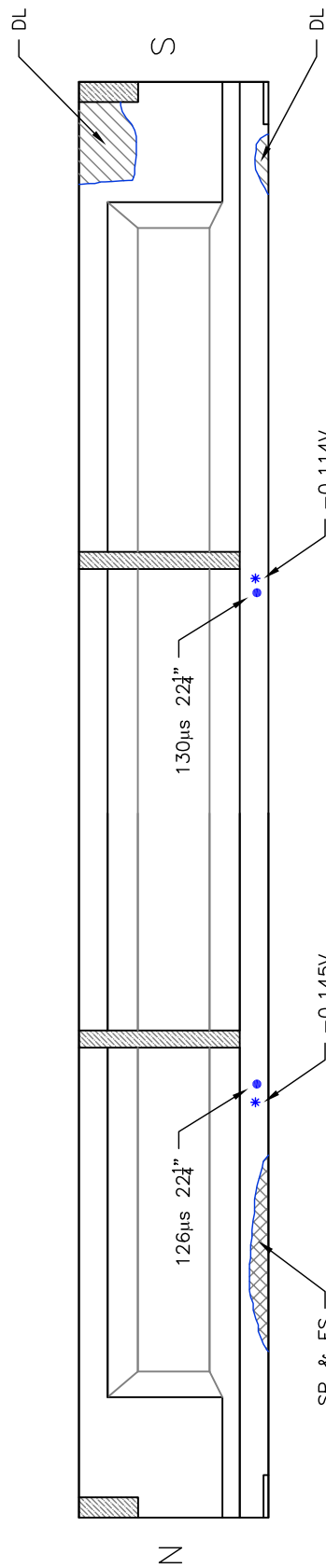

G1—West Elevation

ALL BEARINGS SEVERELY CORRODED

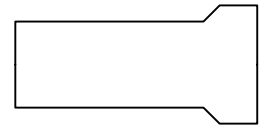

North End

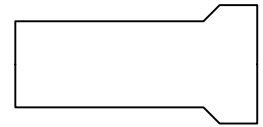

South End

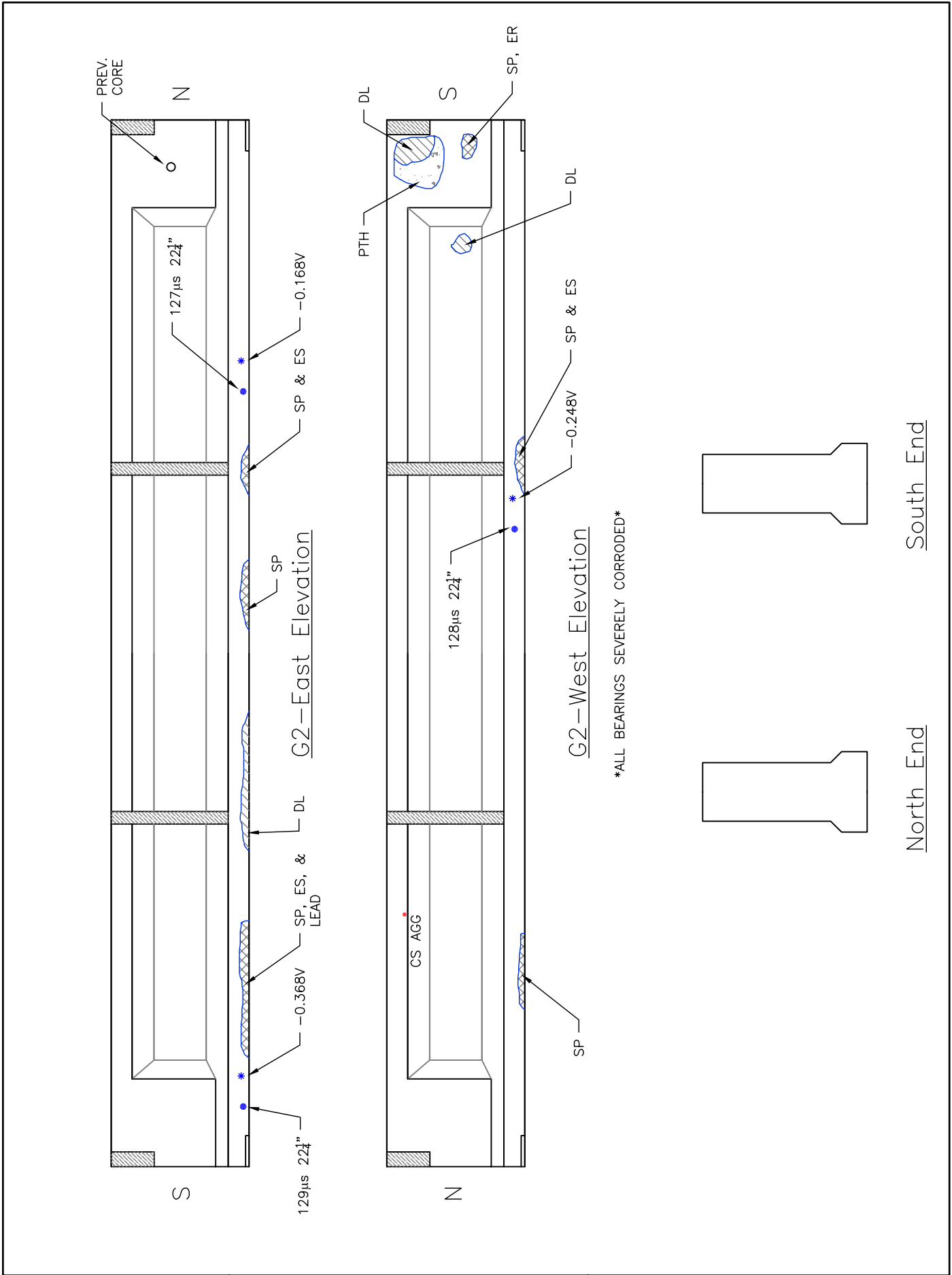

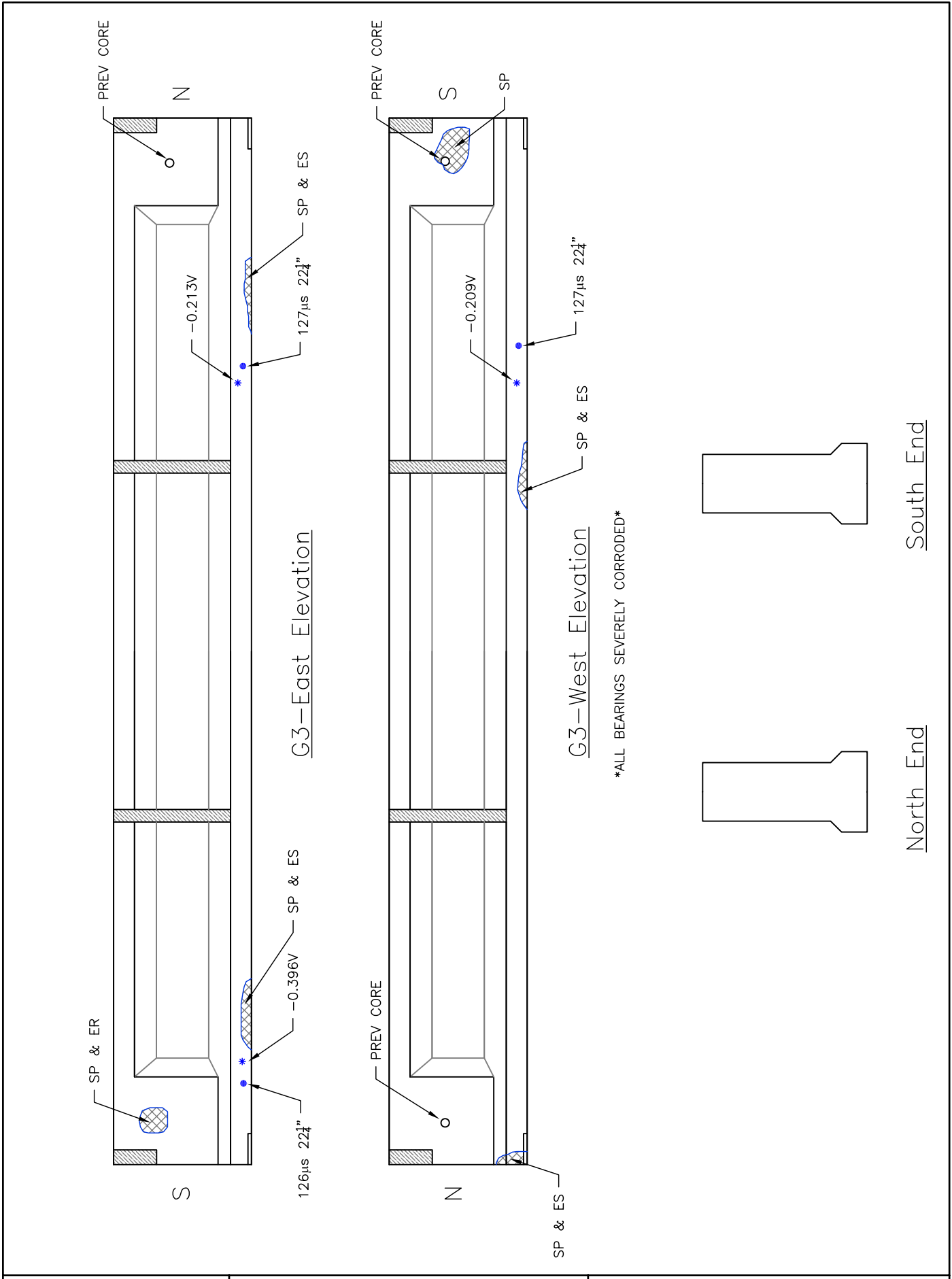

ALL BEARINGS SEVERELY CORRODED



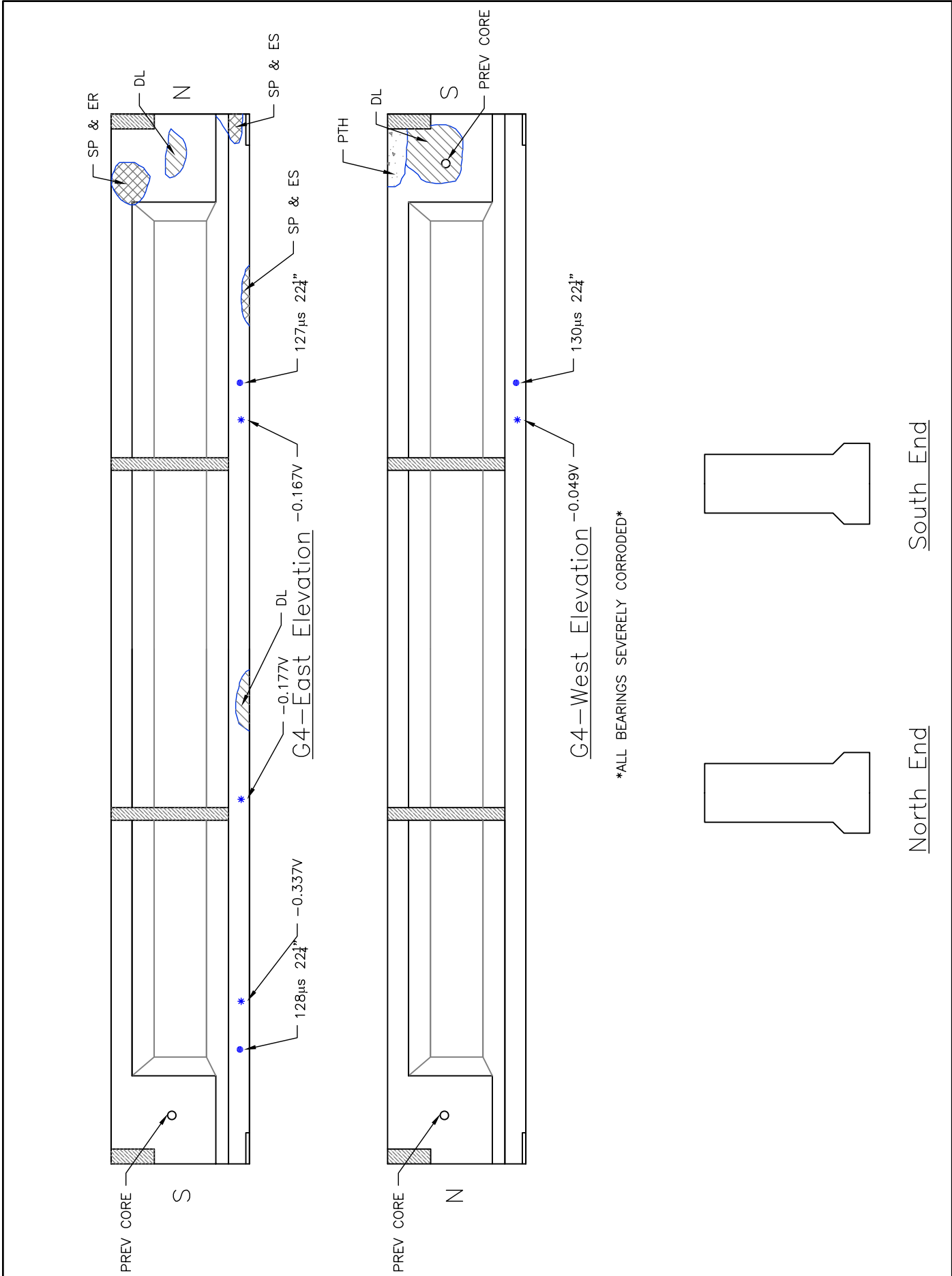

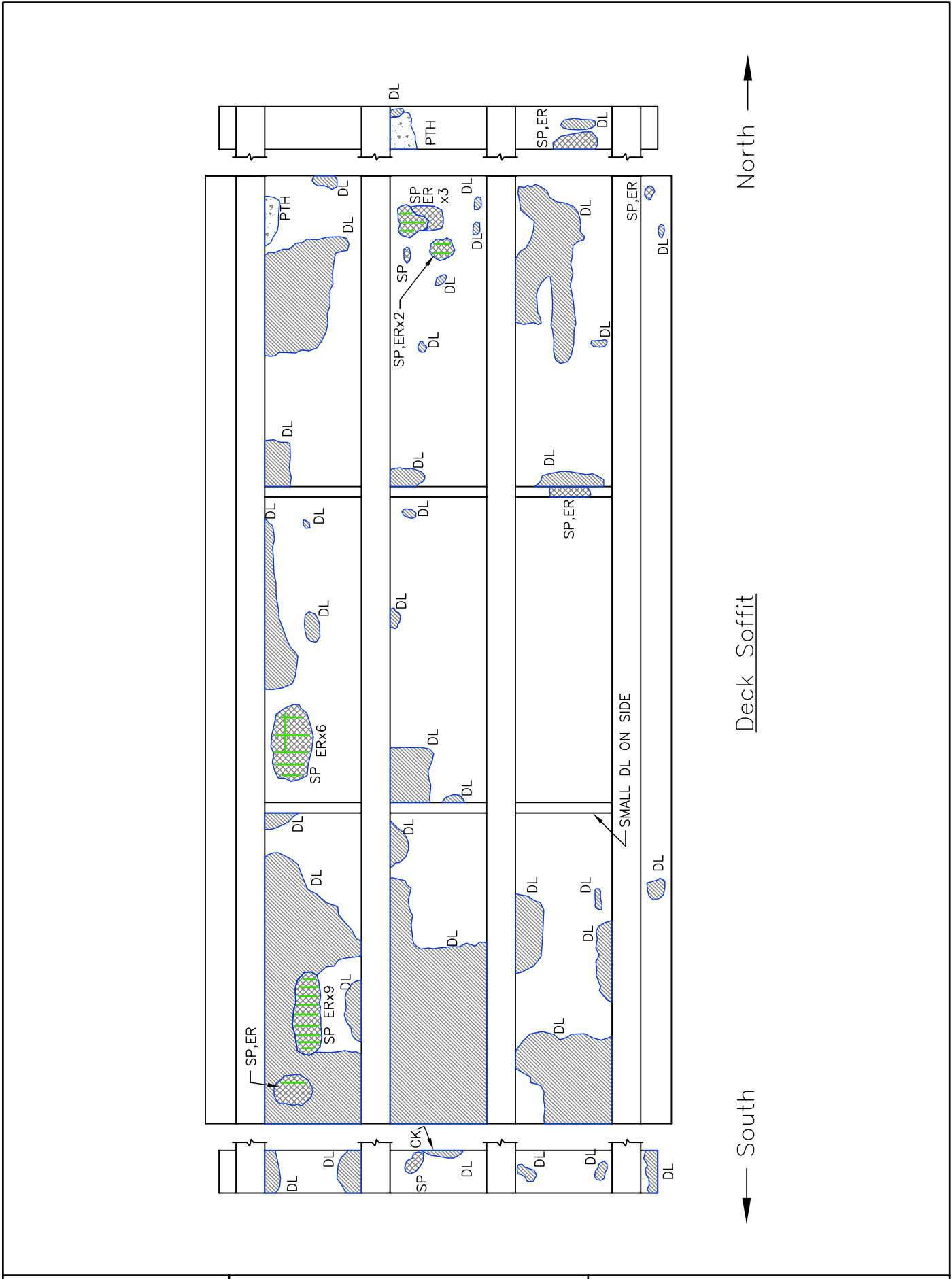

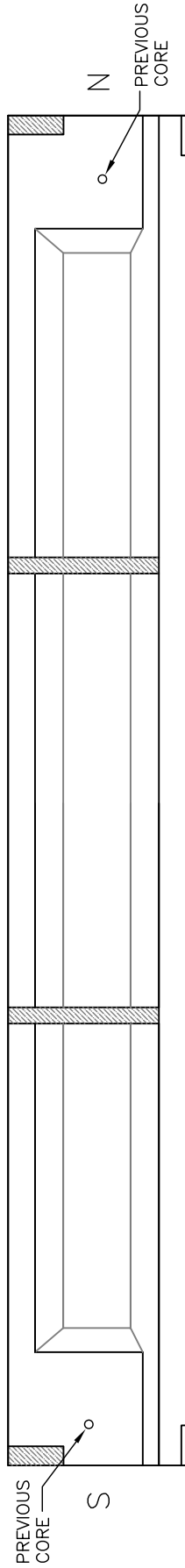

G1—East Elevation

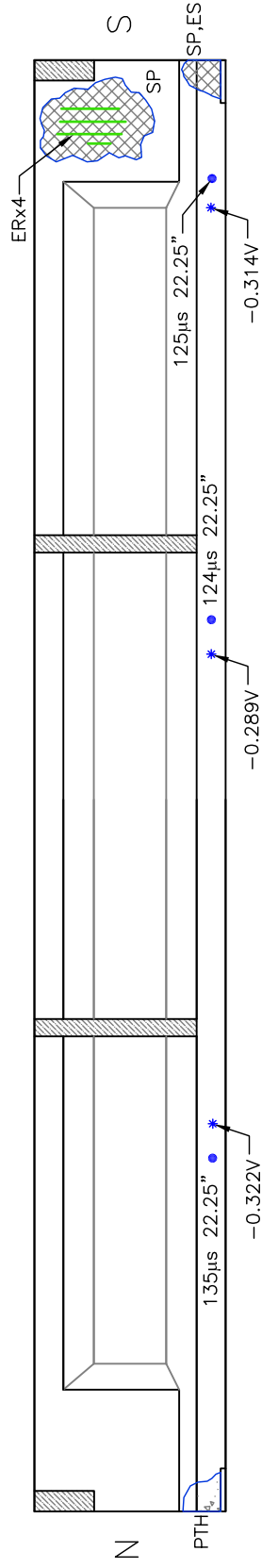

G1—West Elevation



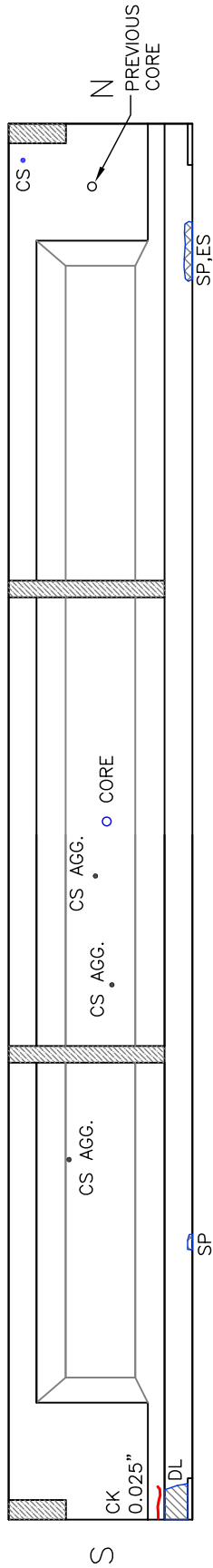

G2—East Elevation

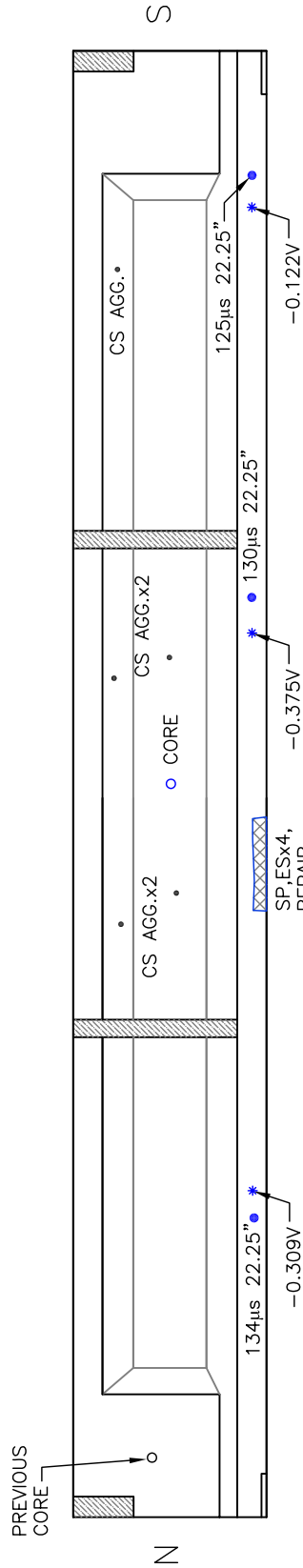

G2—West Elevation



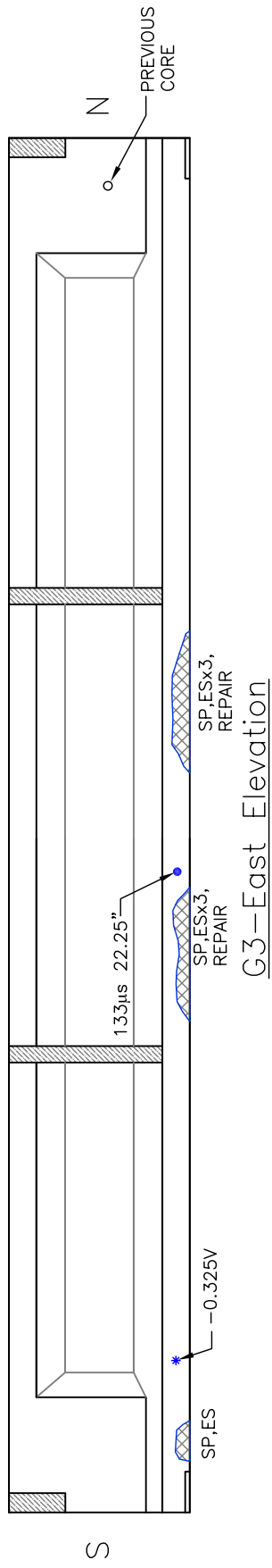

G3—East Elevation

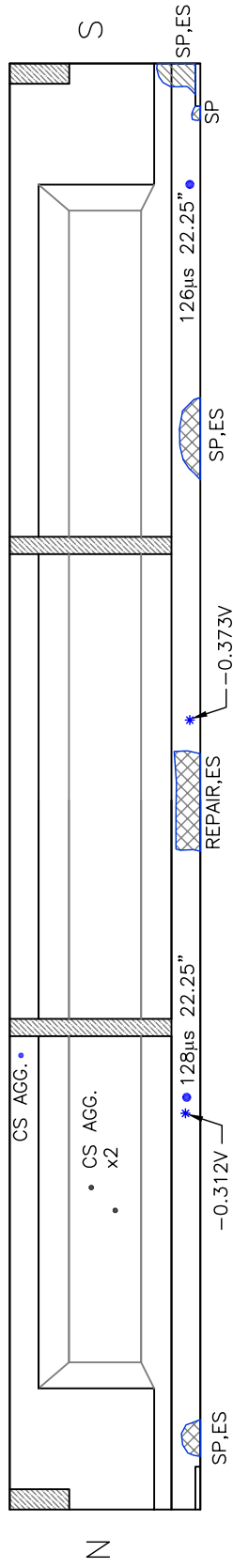

G3—West Elevation



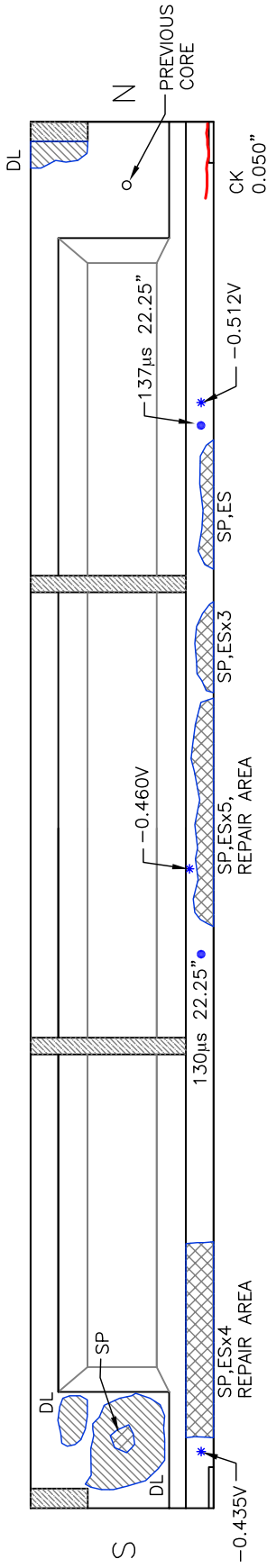

G4--East Elevation

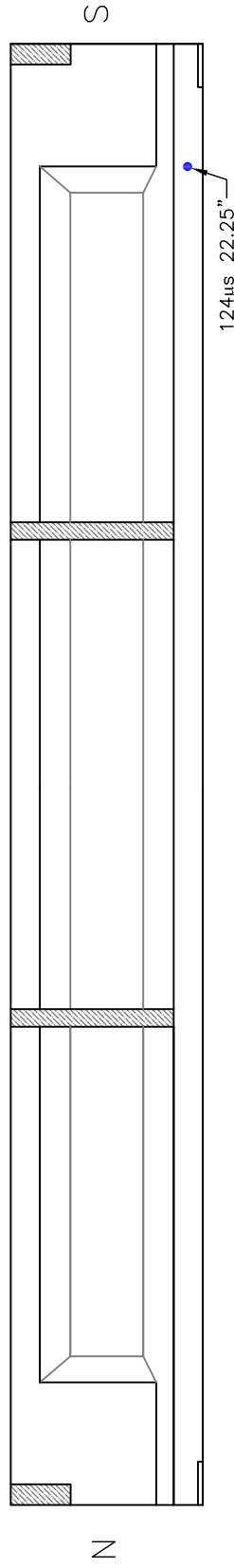

G4--West Elevation



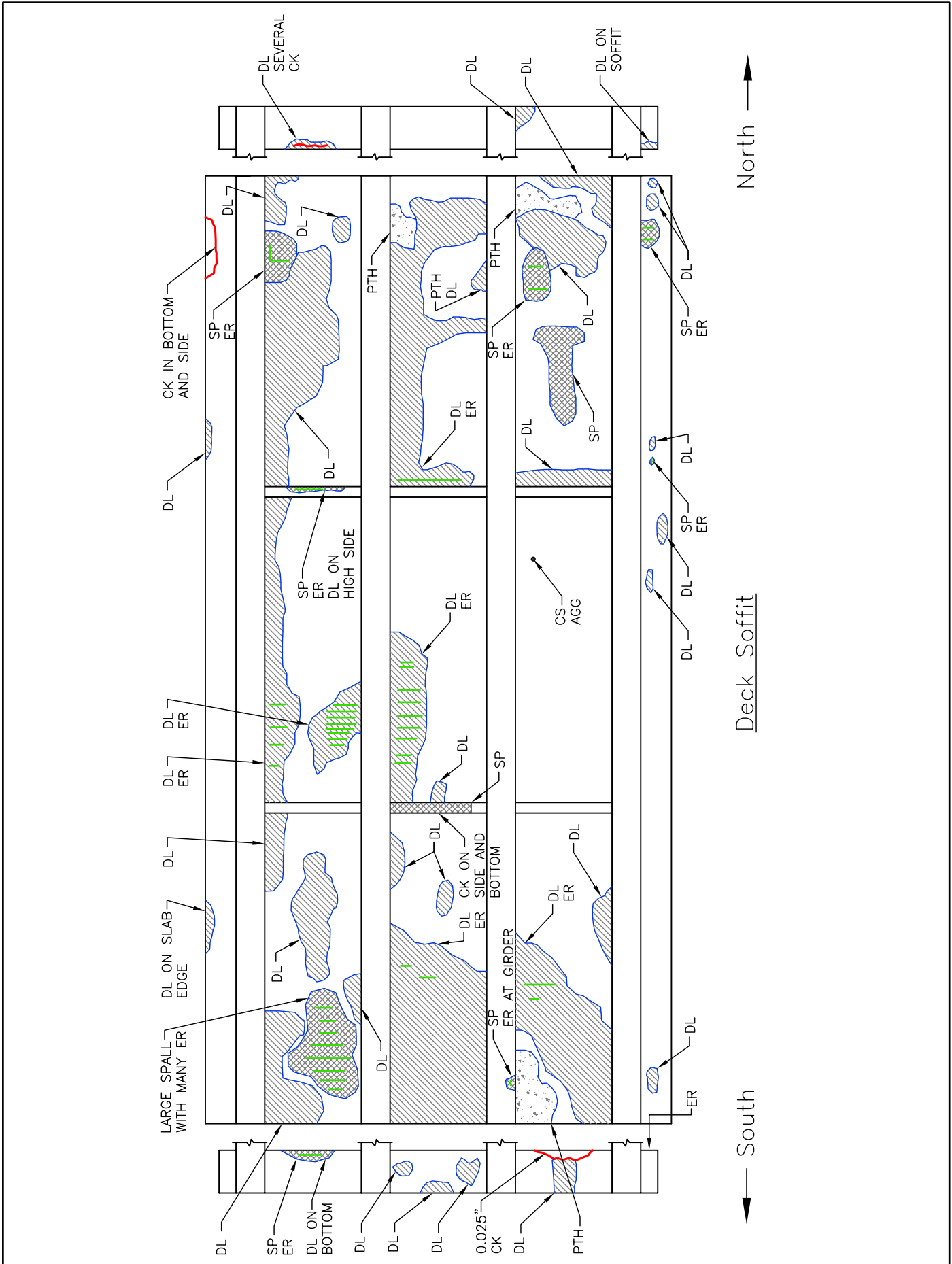

North →

Deck Soffit

← South

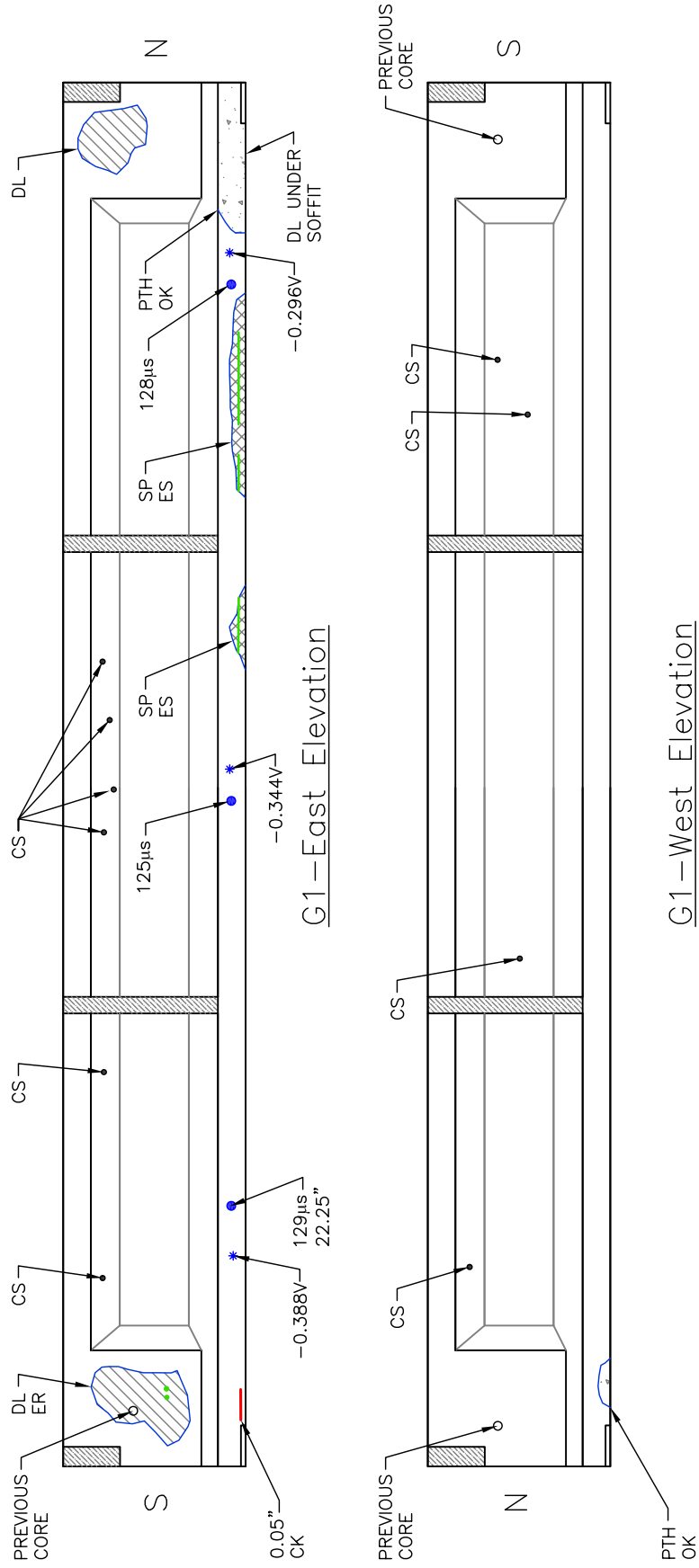

G1—West Elevation

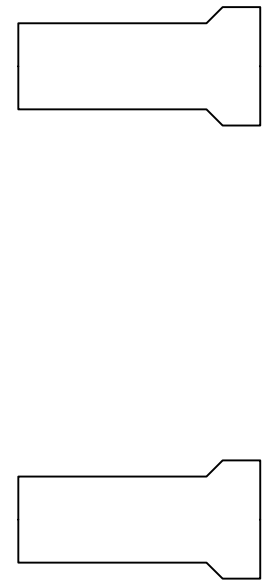

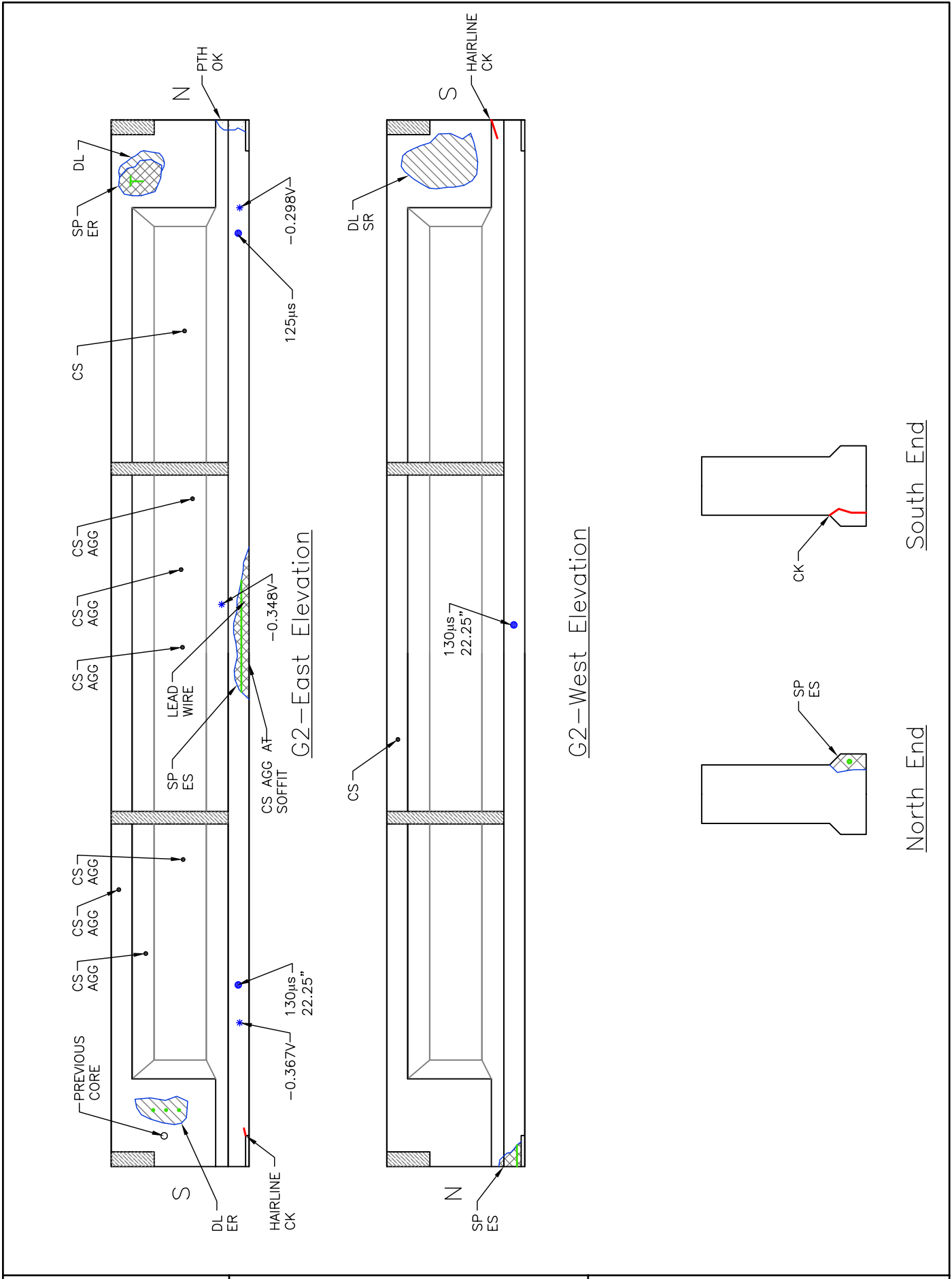

G2—West Elevation

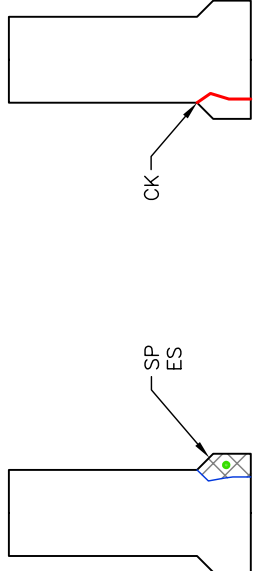

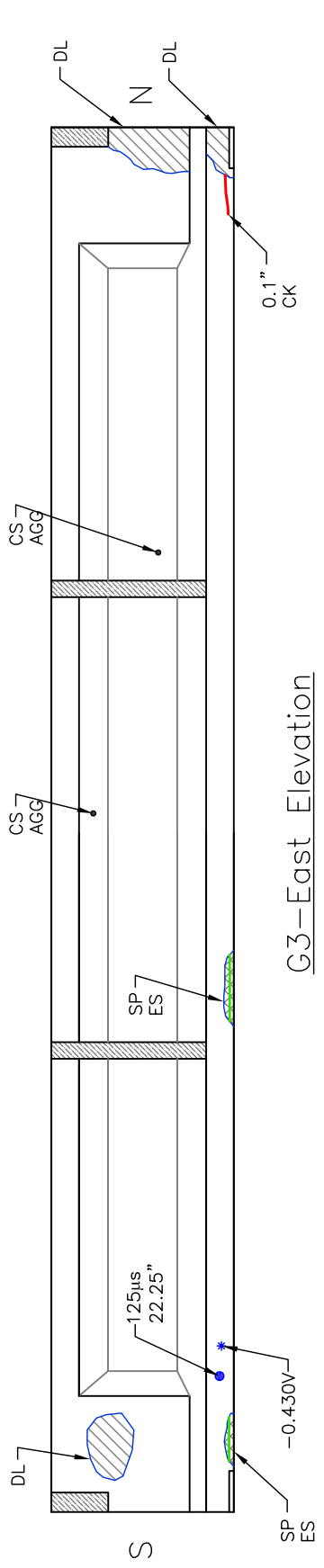

G3—East Elevation

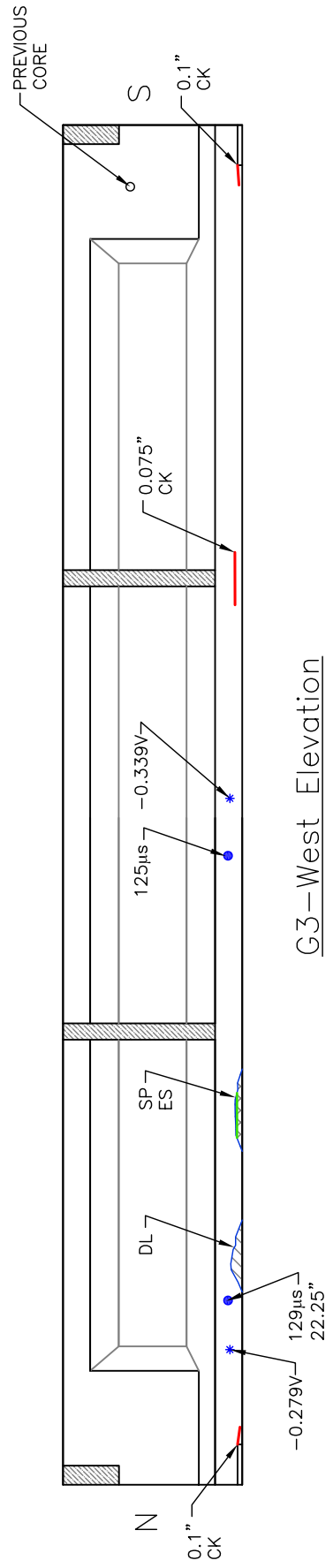

G3—West Elevation

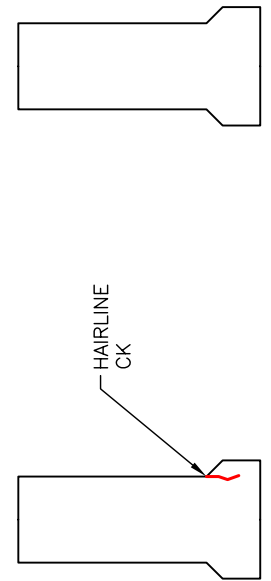

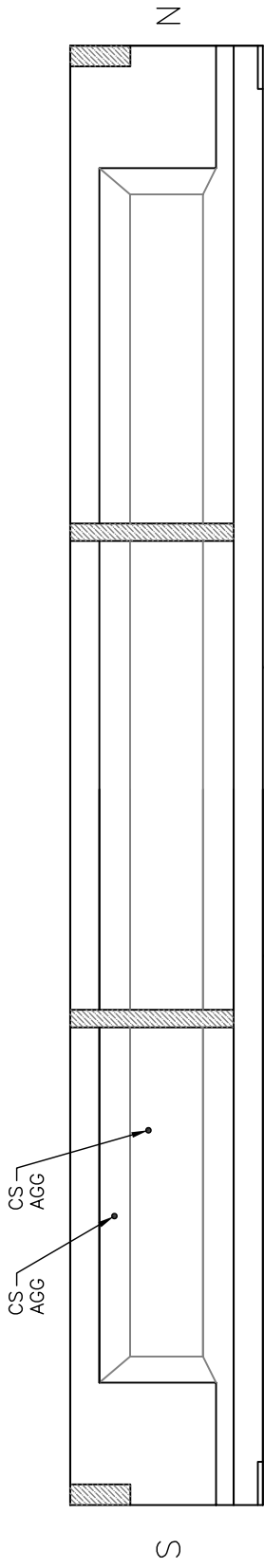

G4--East Elevation

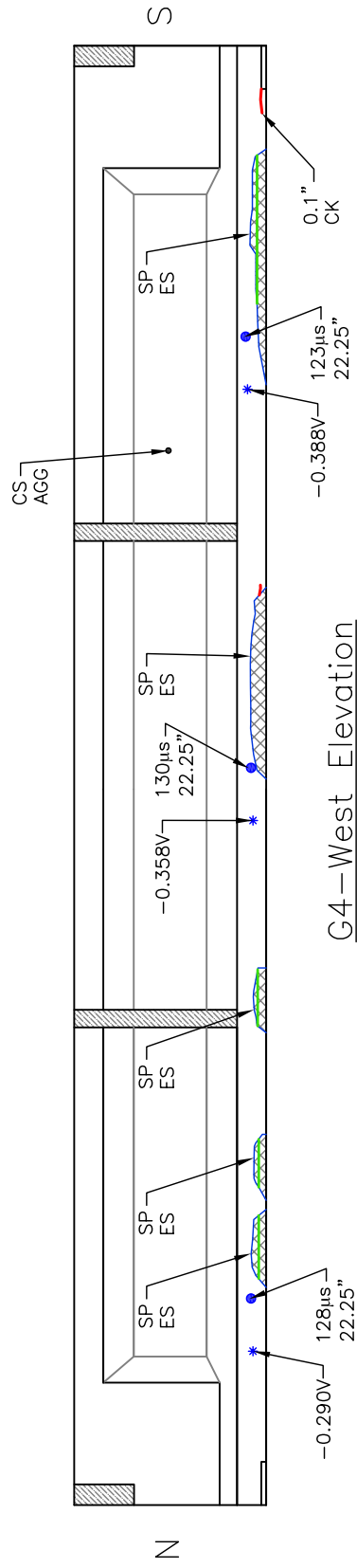

G4--West Elevation

