

**APPENDIX D.1A: FIELD DATA SHEETS - HIGH BENTS**

<b>Field Sheet Notation Legend</b>	
CK/CR	Crack ( width noted in inches)
CS/RS	Corrosion/rust stain
CS AGG	Corrosion stain at exposed aggregate
DIA	Diaphragm
DIAG	Diagonal
DL	Delamination
EF	Efflorescence
ER	Exposed rebar
ERx2	2 exposed bars
ES	Exposed prestressing strand
ESx2	2 exposed strands
HL CK	Hairline crack
HVY	Heavy
PTH	Patch
SP	Spall
SR	Shotcrete repair
-0.XXX V	Half-cell potential measurement in volts
XXX $\mu$ s	Ultrasonic pulse velocity measurement in micro seconds

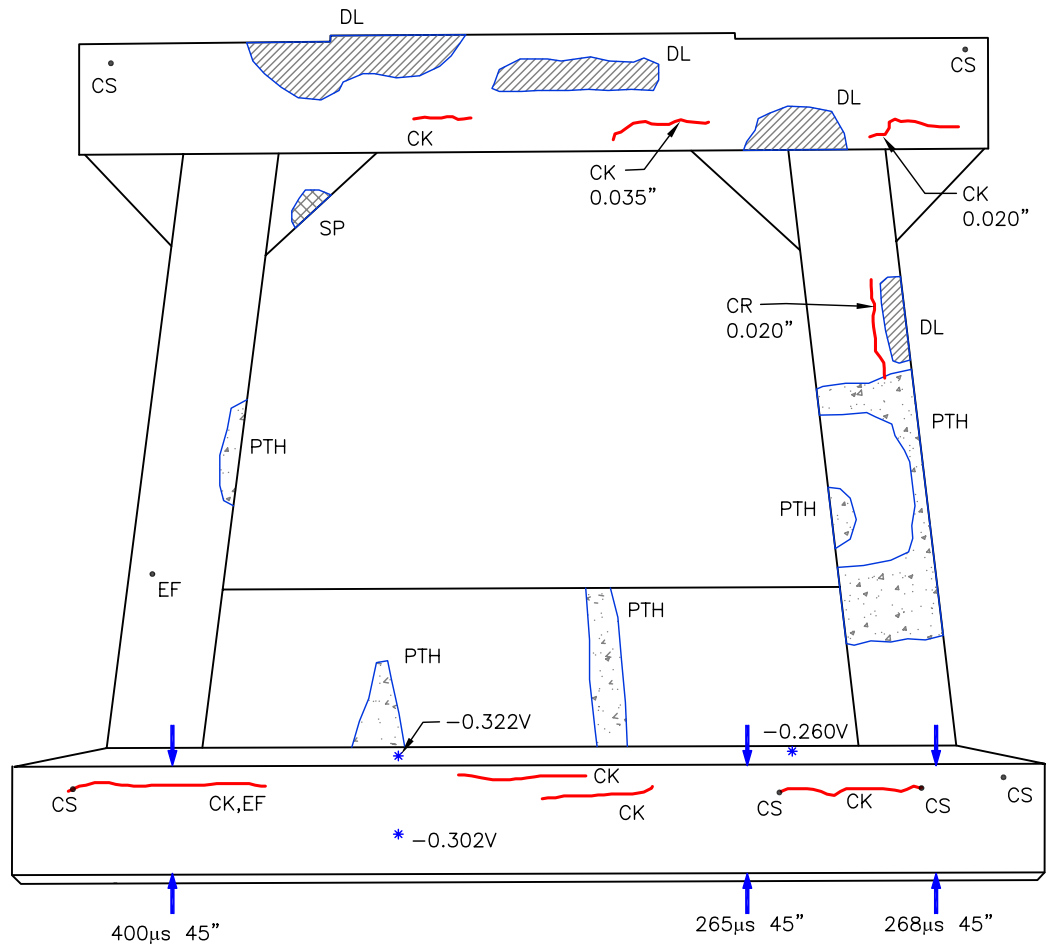

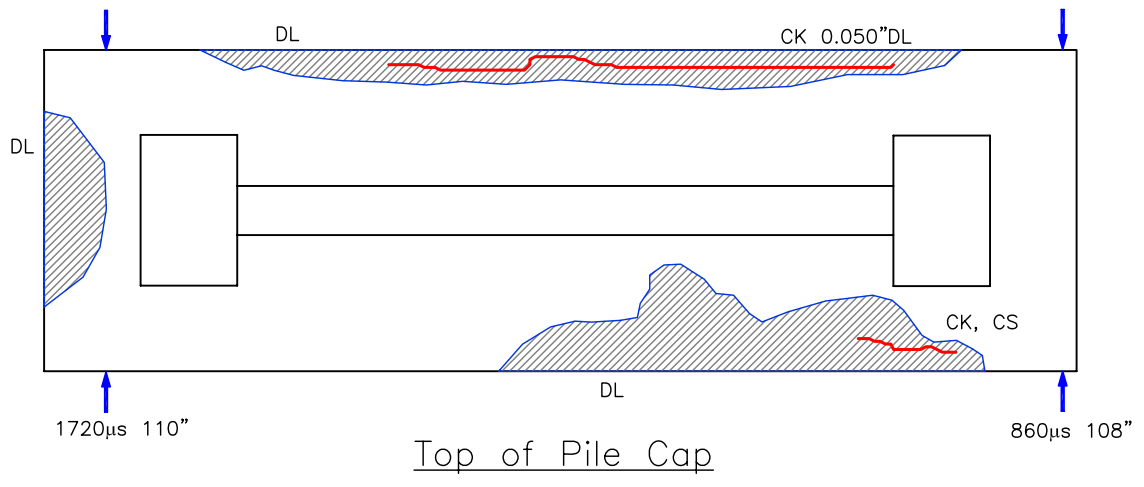
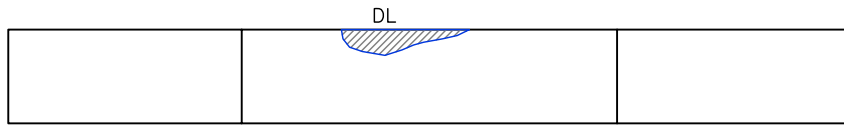

Top of Bent Cap

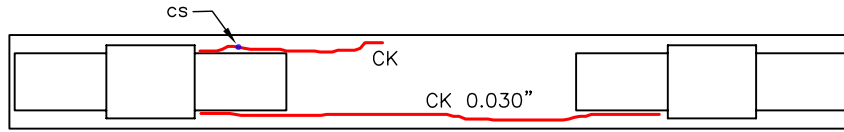

Bottom of Bent Cap

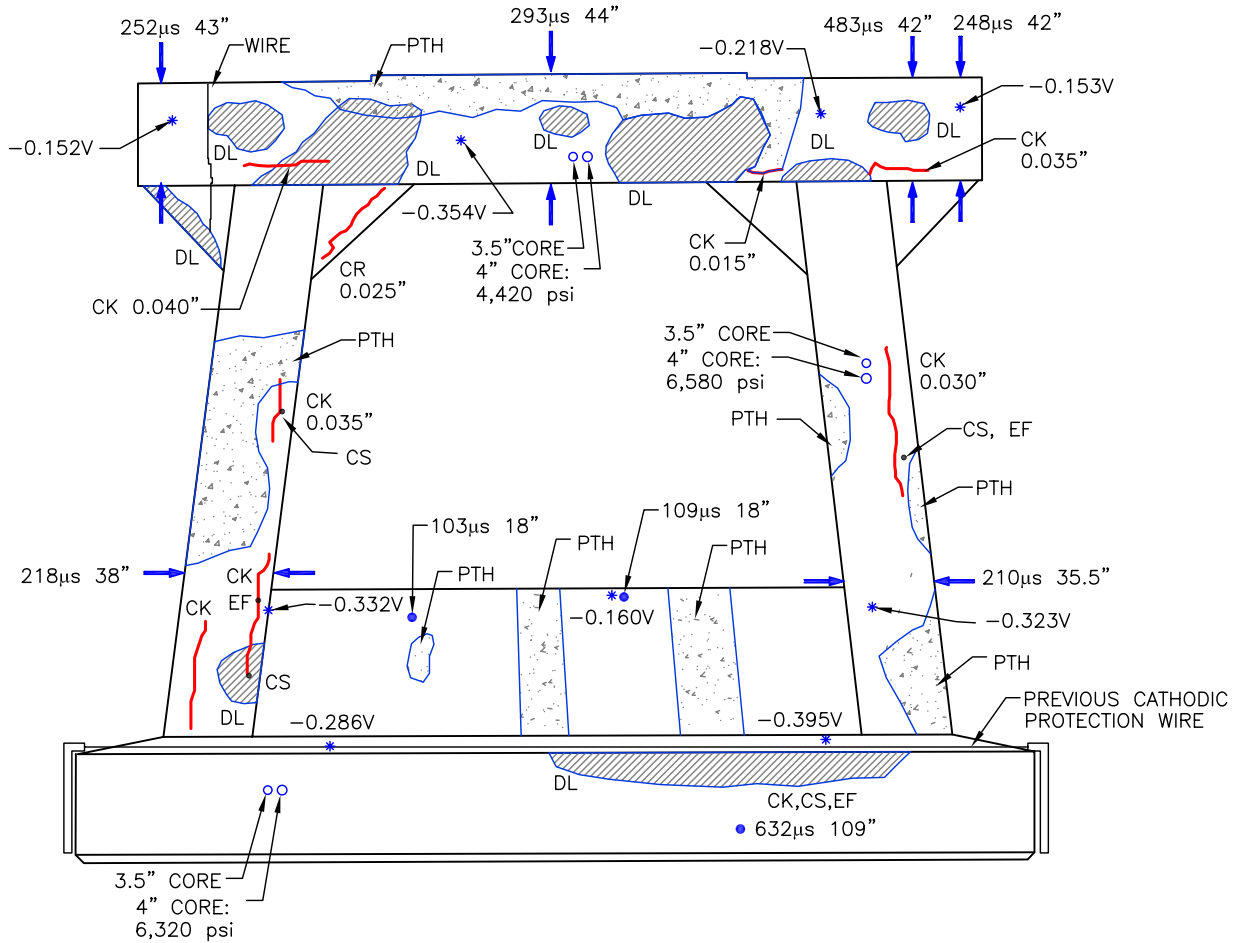

South Elevation

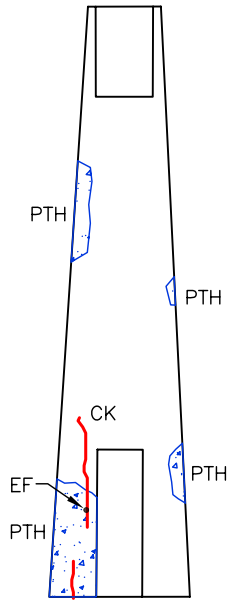

West Int. Side

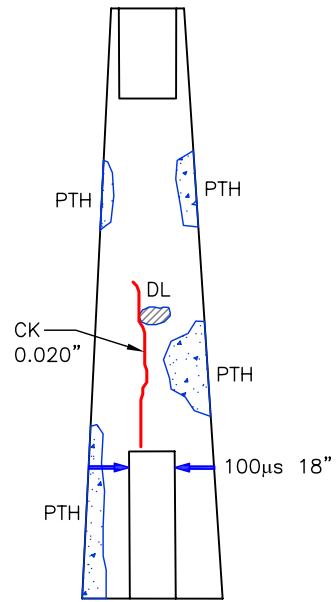

East Int. Side

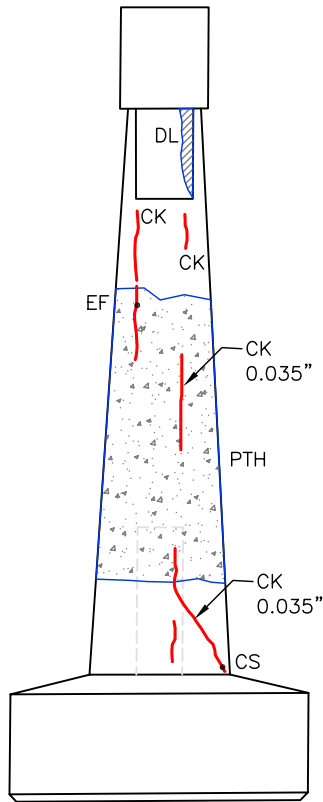

West Ext. Side

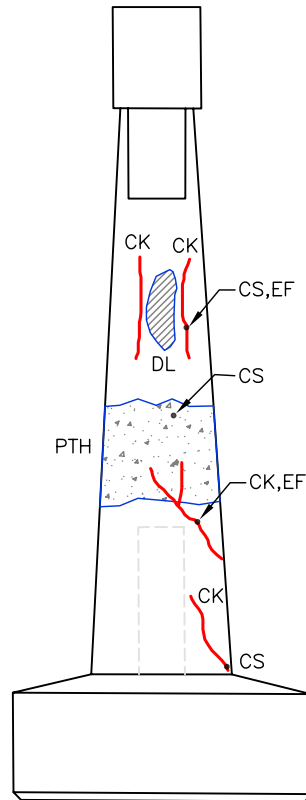

East Ext. Side

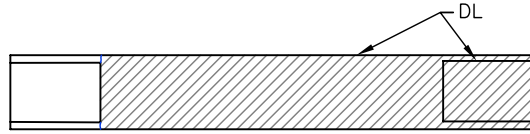

Top of Middle Beam

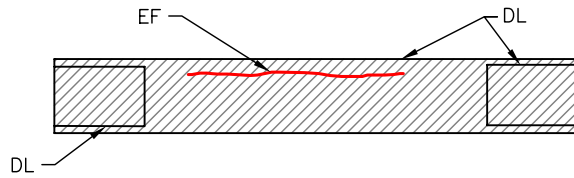

Bottom of Middle Beam

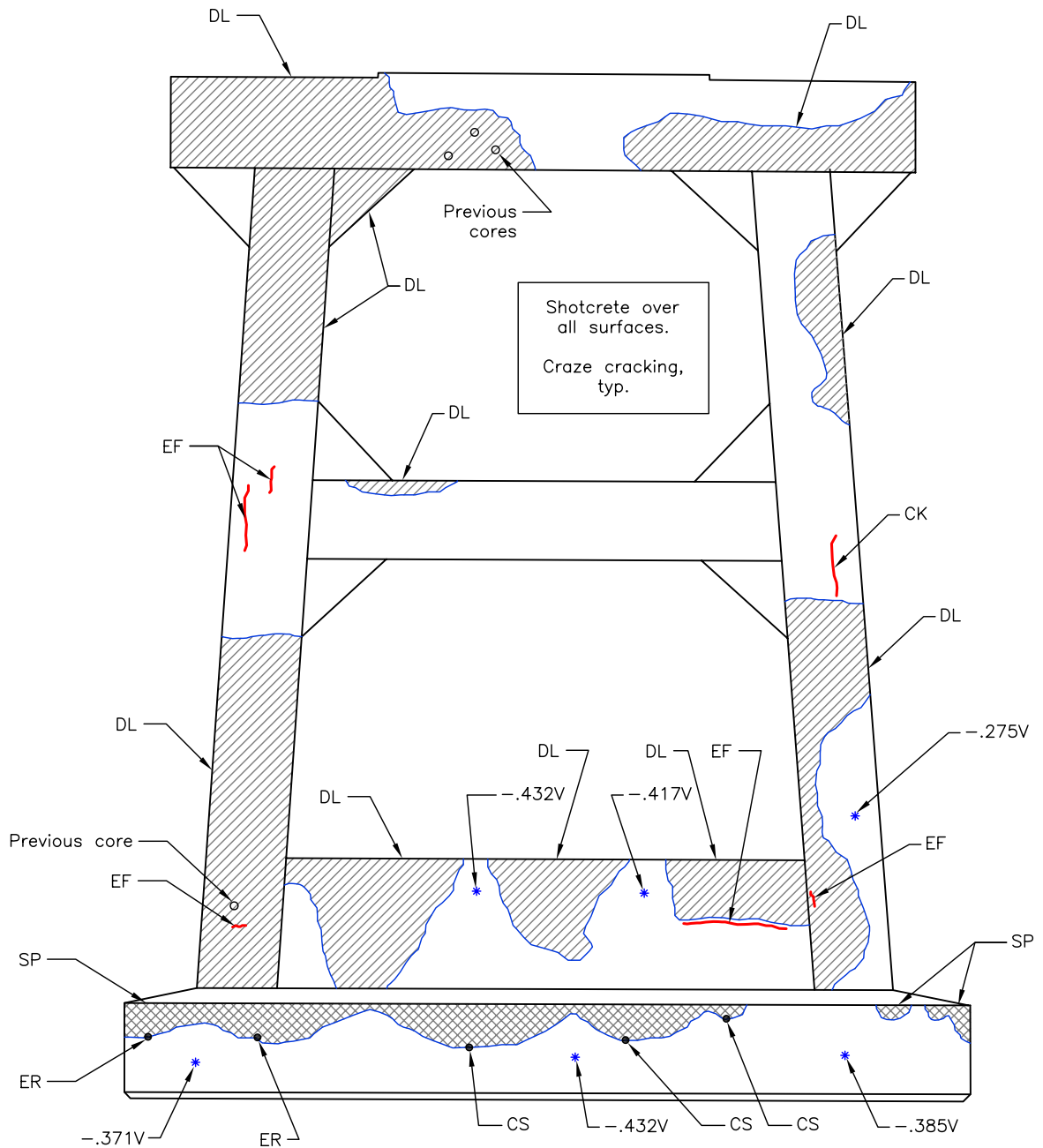

North Elevation

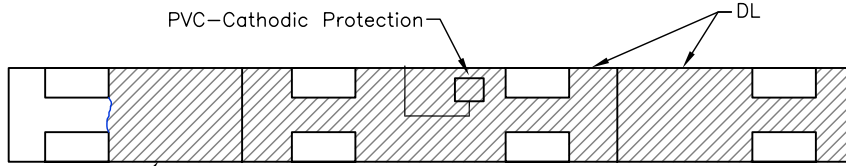

Top of Bent Cap

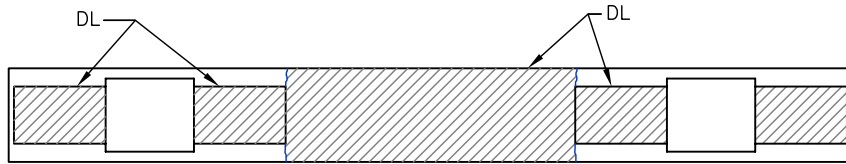

Bottom of Bent Cap

Shotcrete over all surfaces.  
Craze cracking, typ.

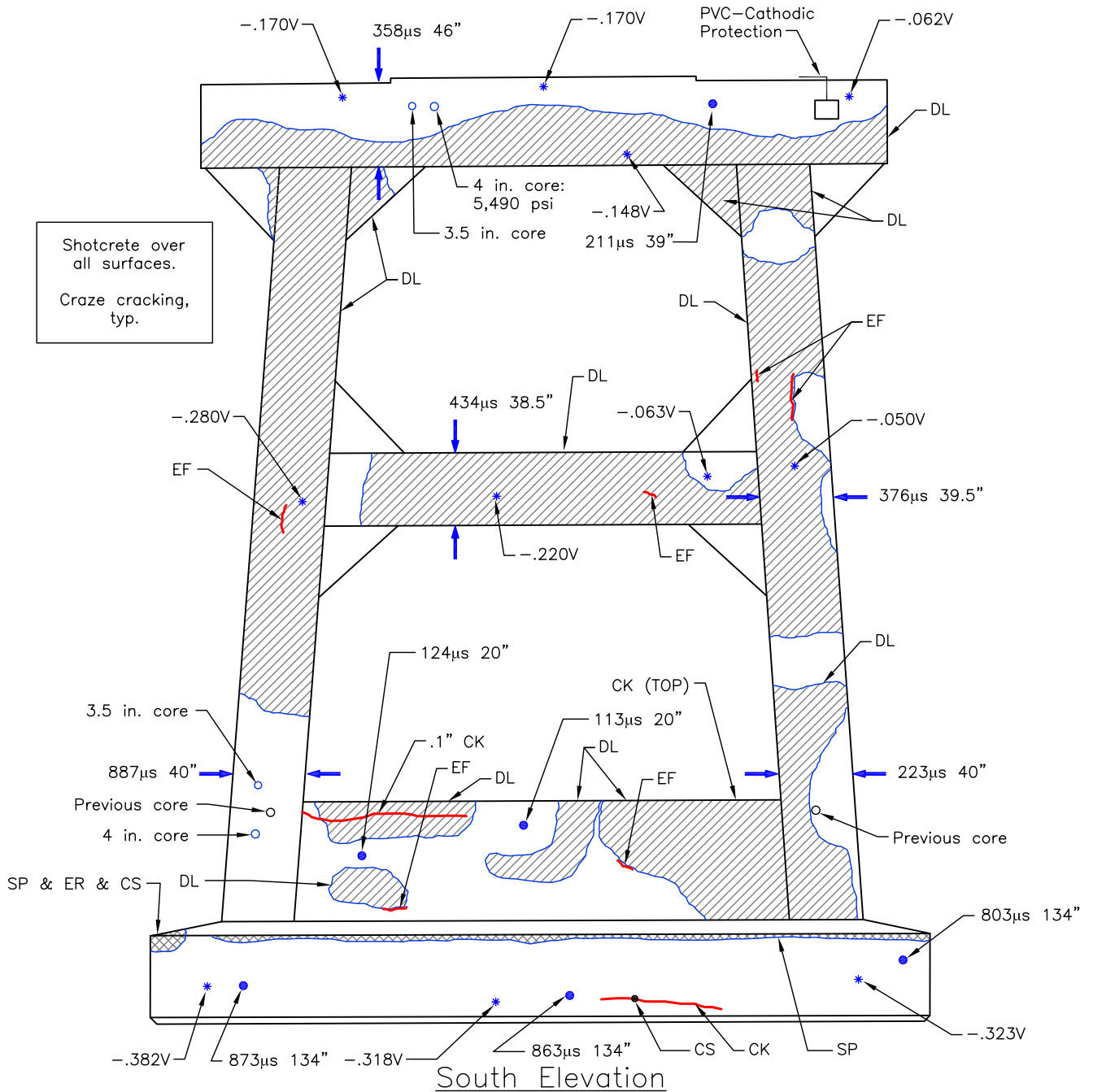

South Elevation

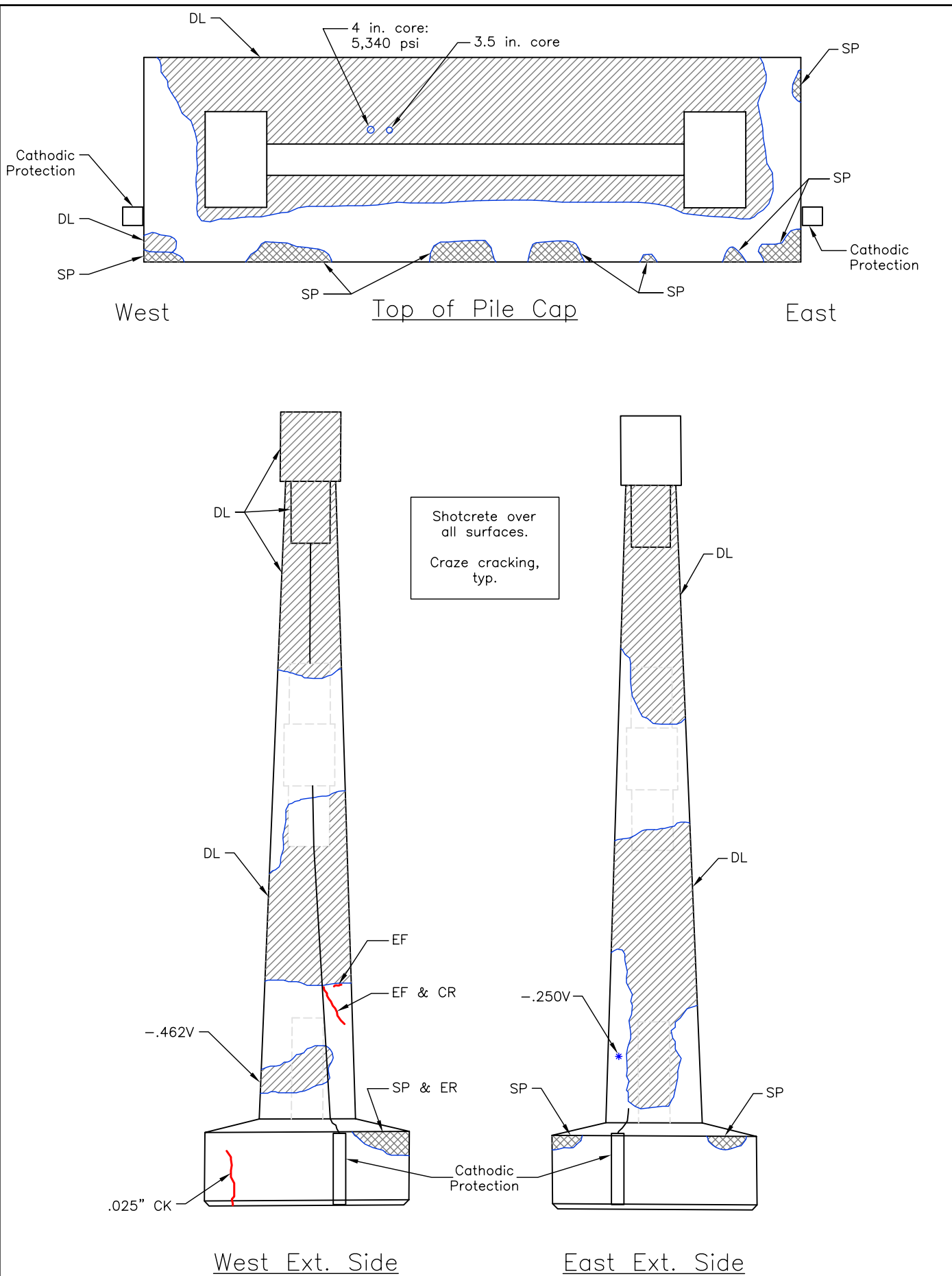



Shotcrete over  
all surfaces.  
Craze cracking,  
typ.

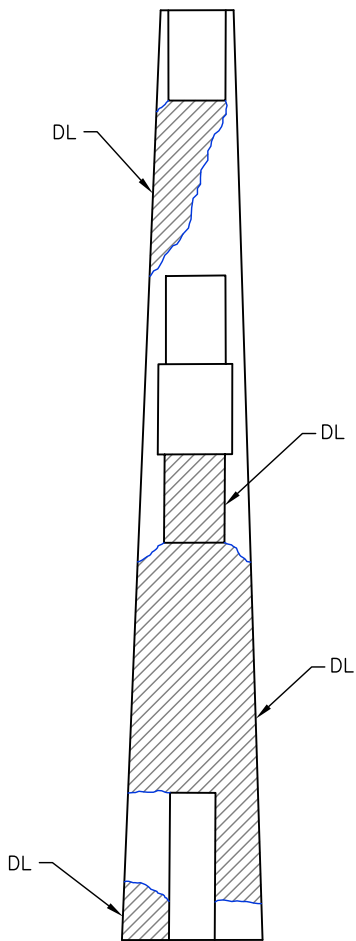

West Int. Side

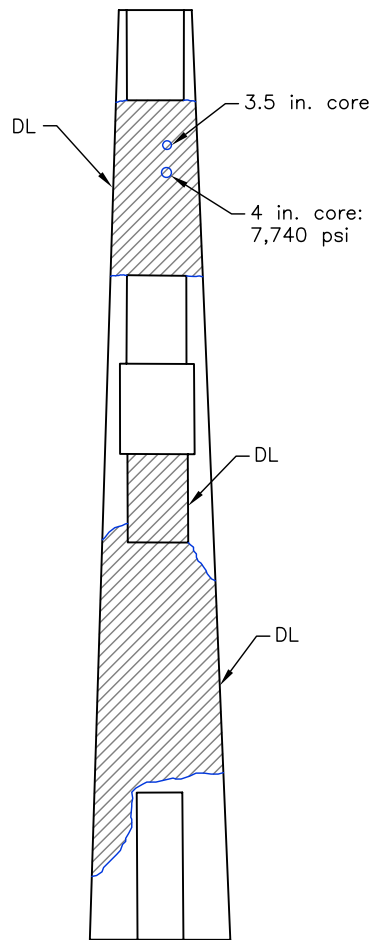

East Int. Side

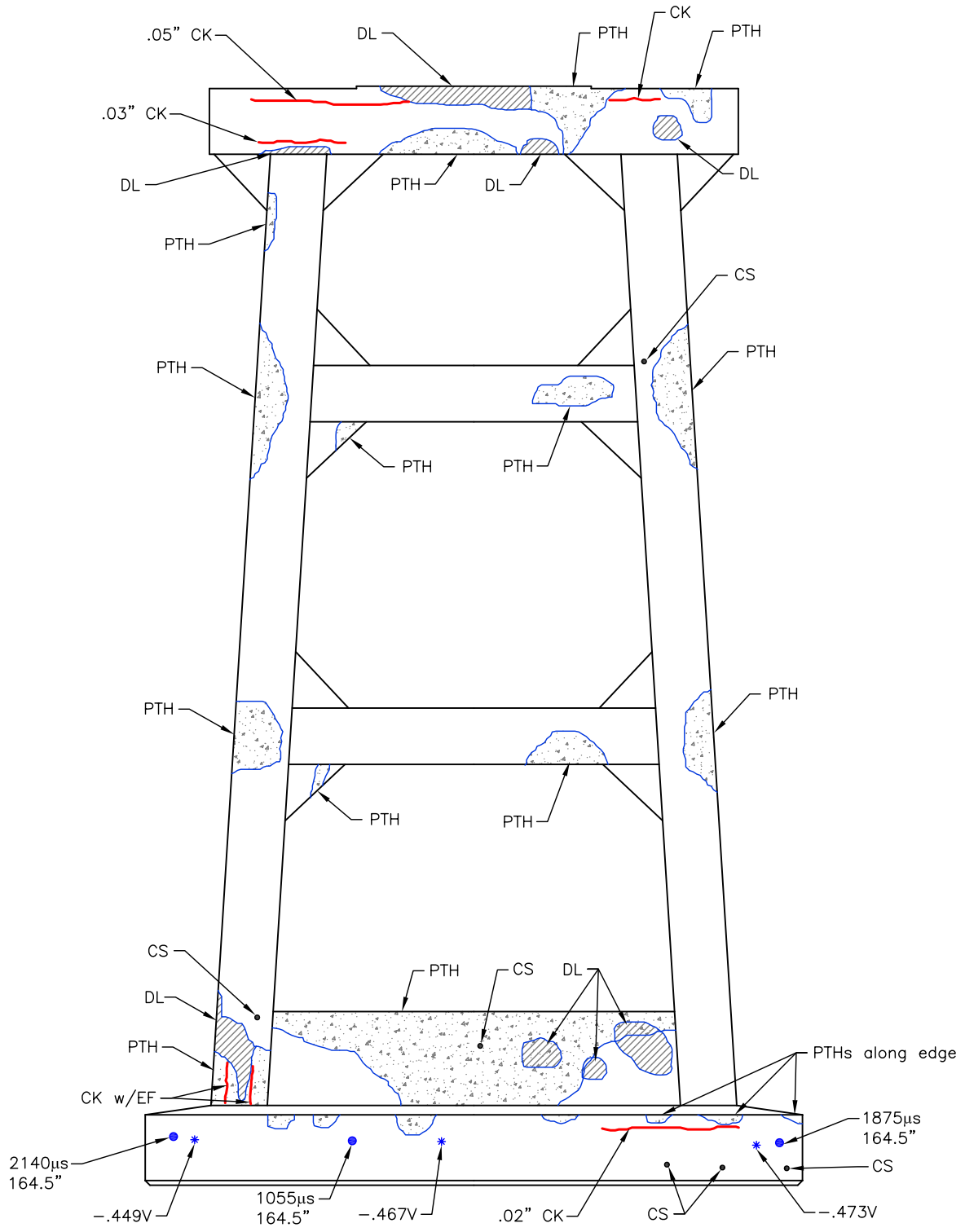

North Elevation

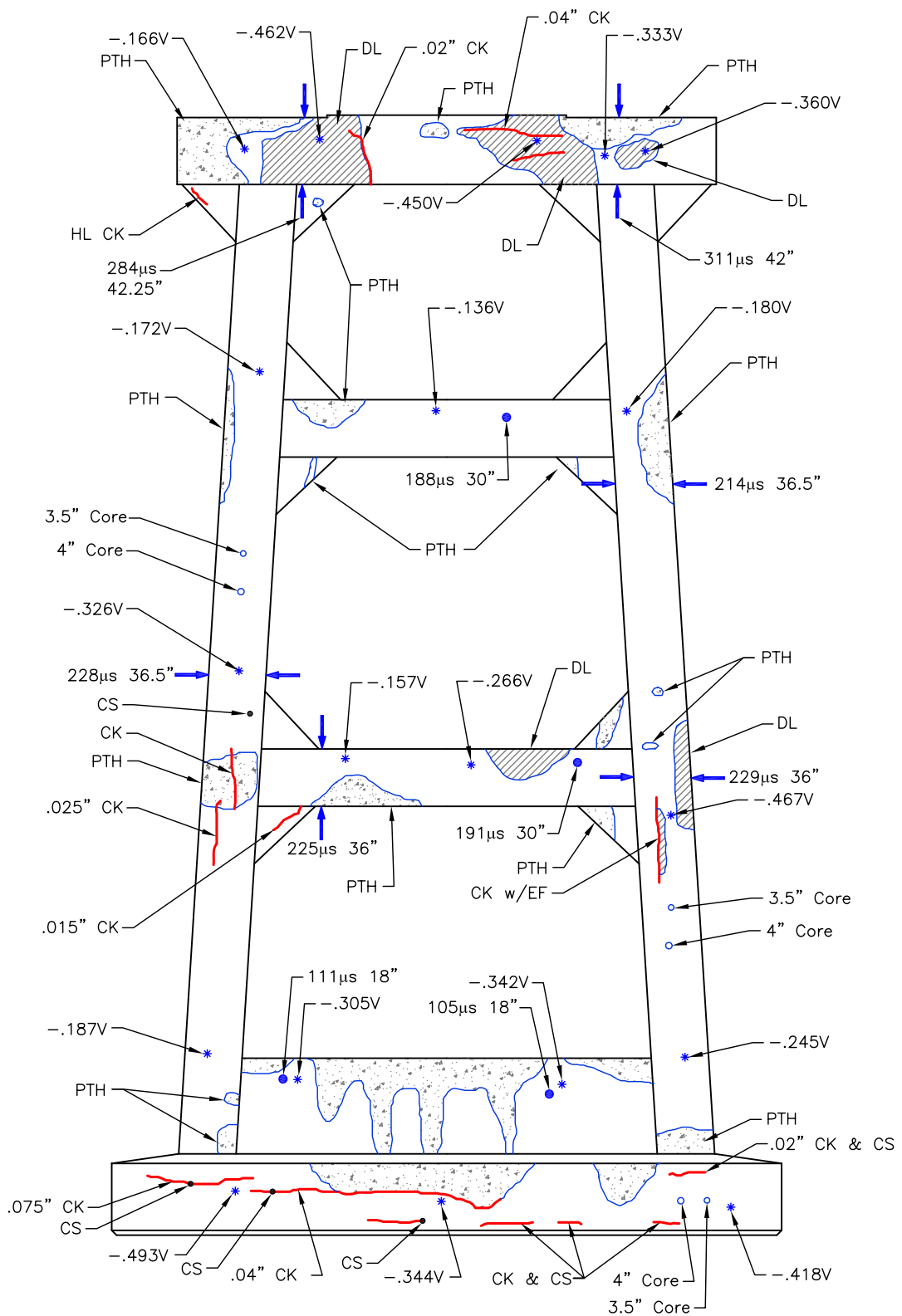

South Elevation

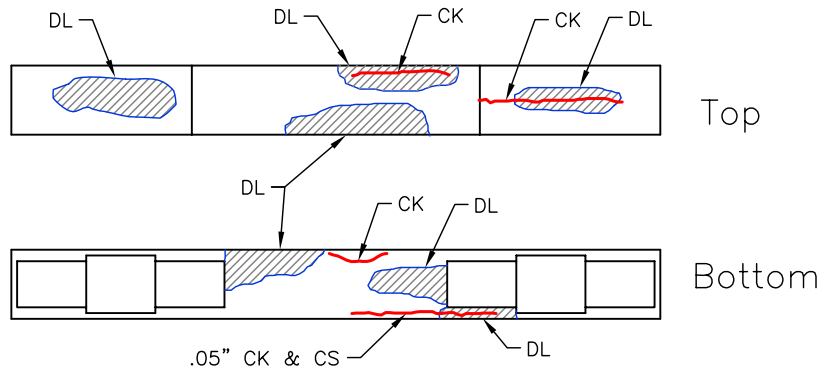

West ← Top and Bottom of Bent Cap → East

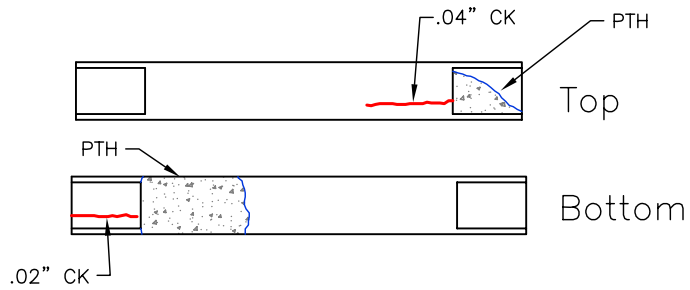
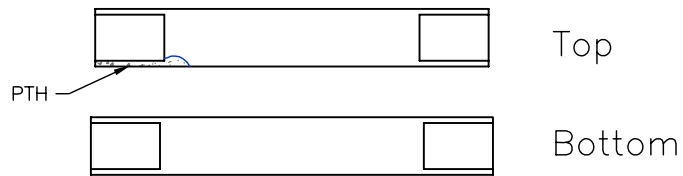

West ← Top and Bottom of Beams → East

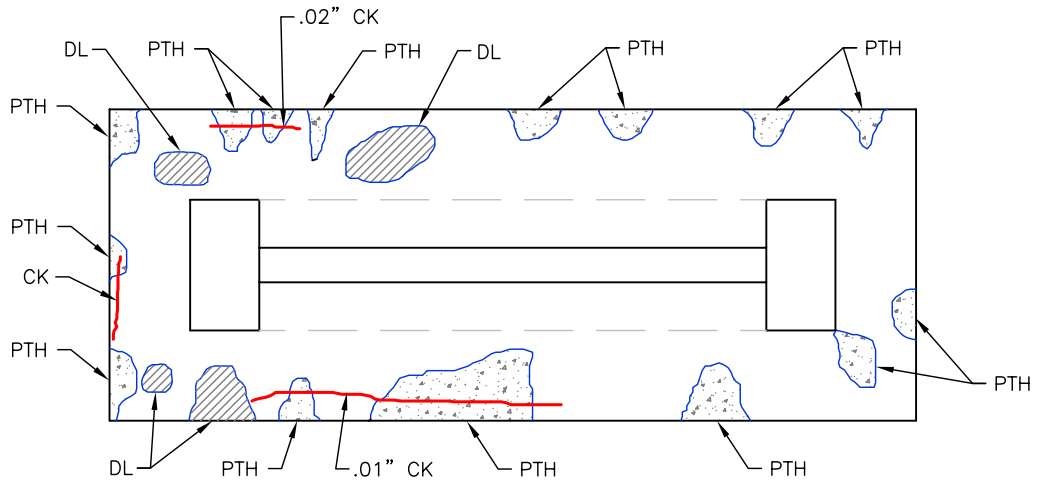

West ← Top of Pile Cap → East

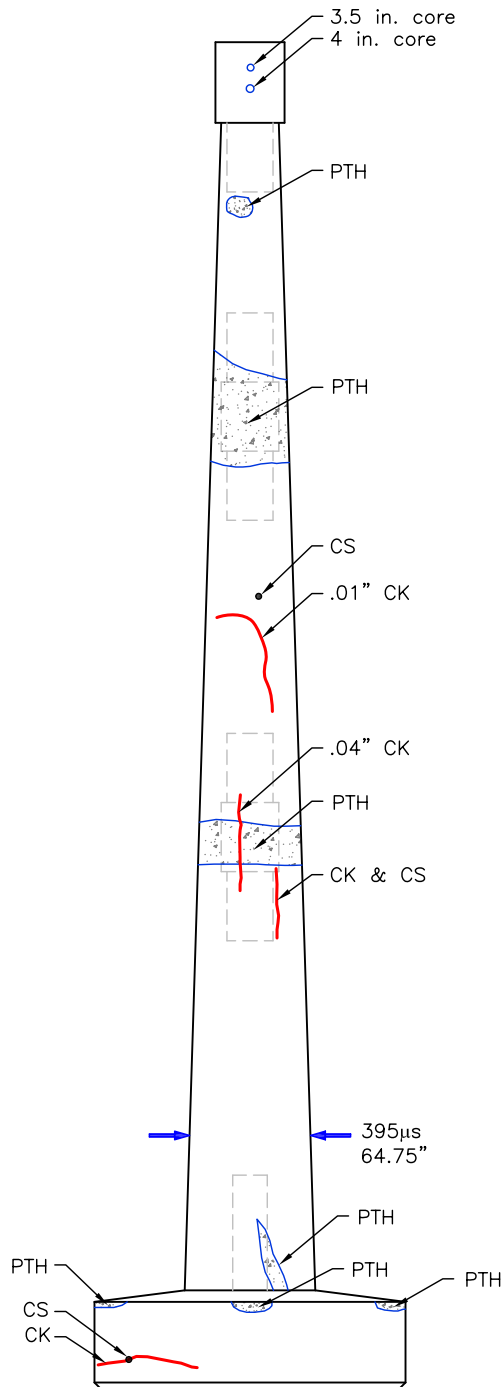

West Ext. Side

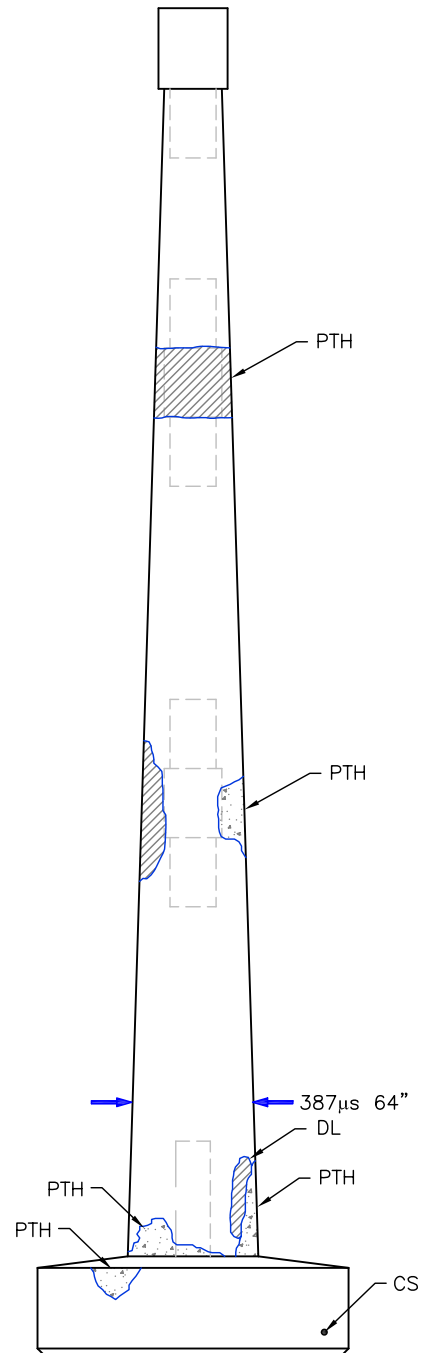

East Ext. Side

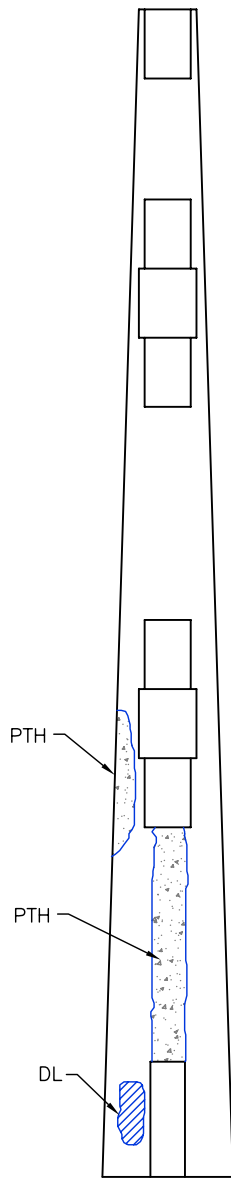

West Int. Side

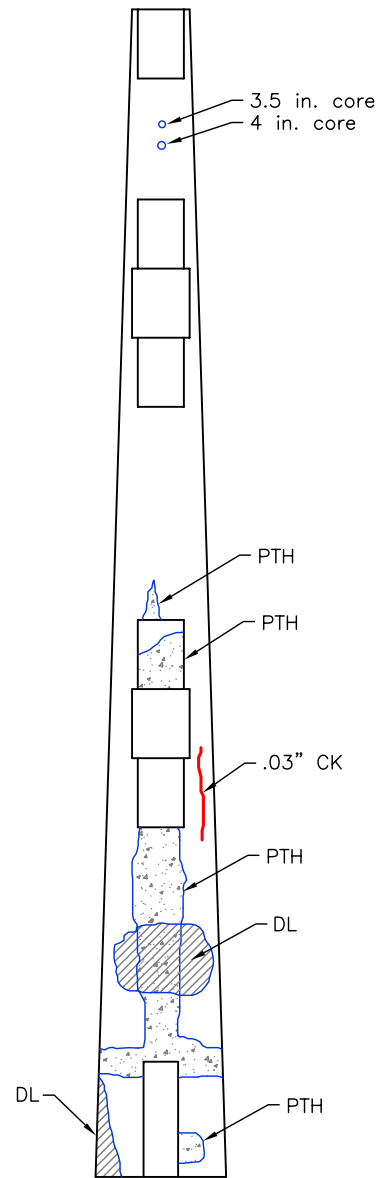

East Int. Side

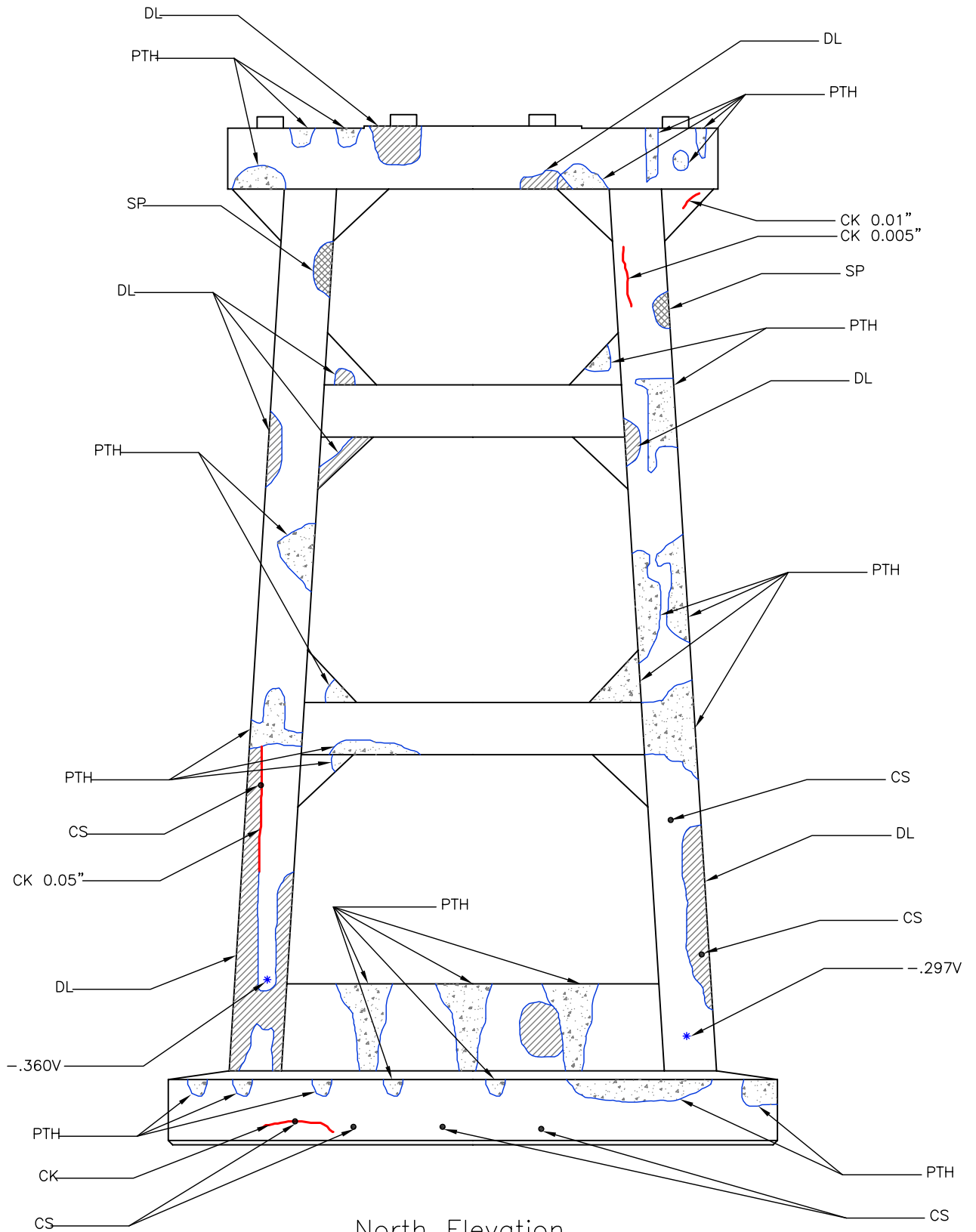

North Elevation

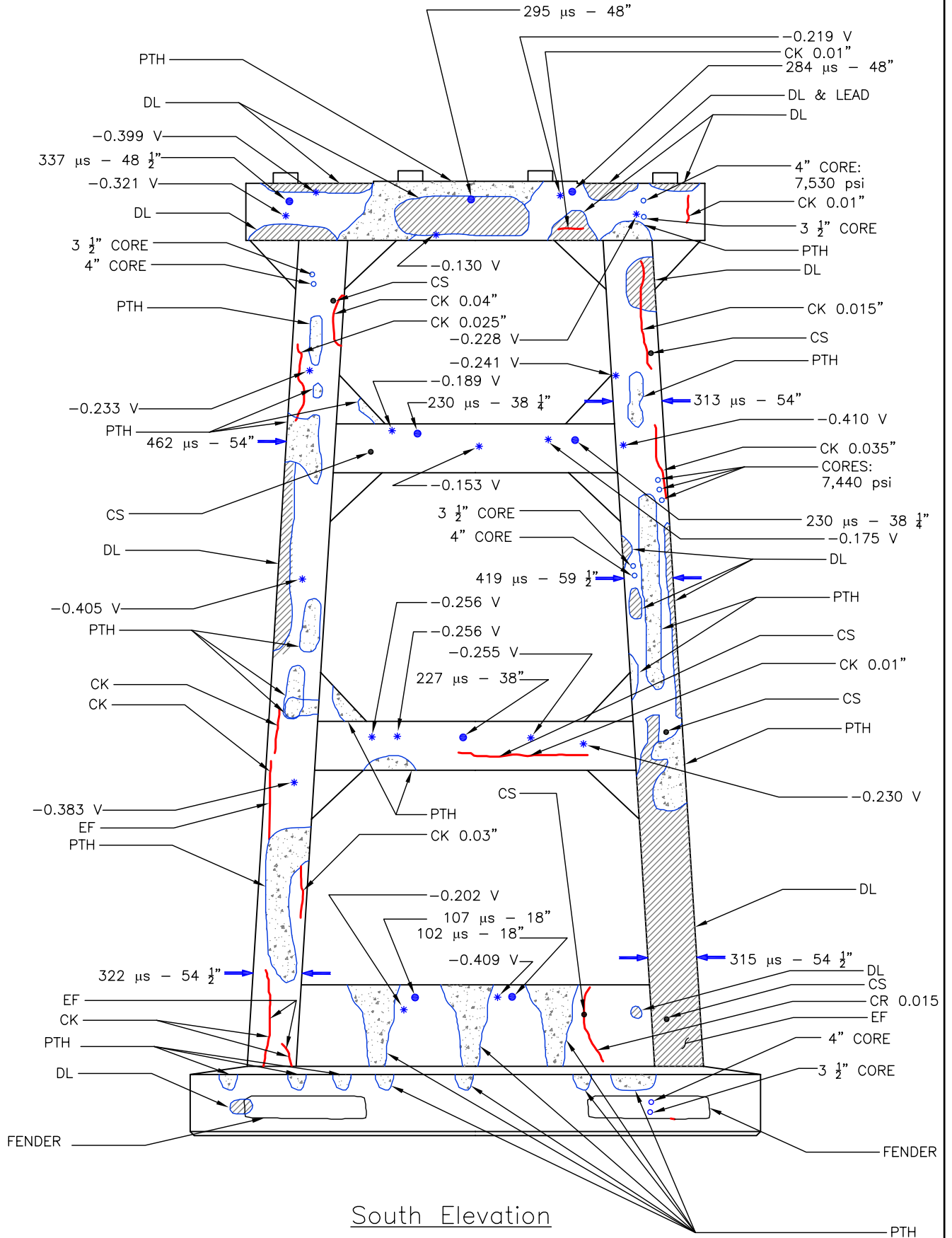

South Elevation



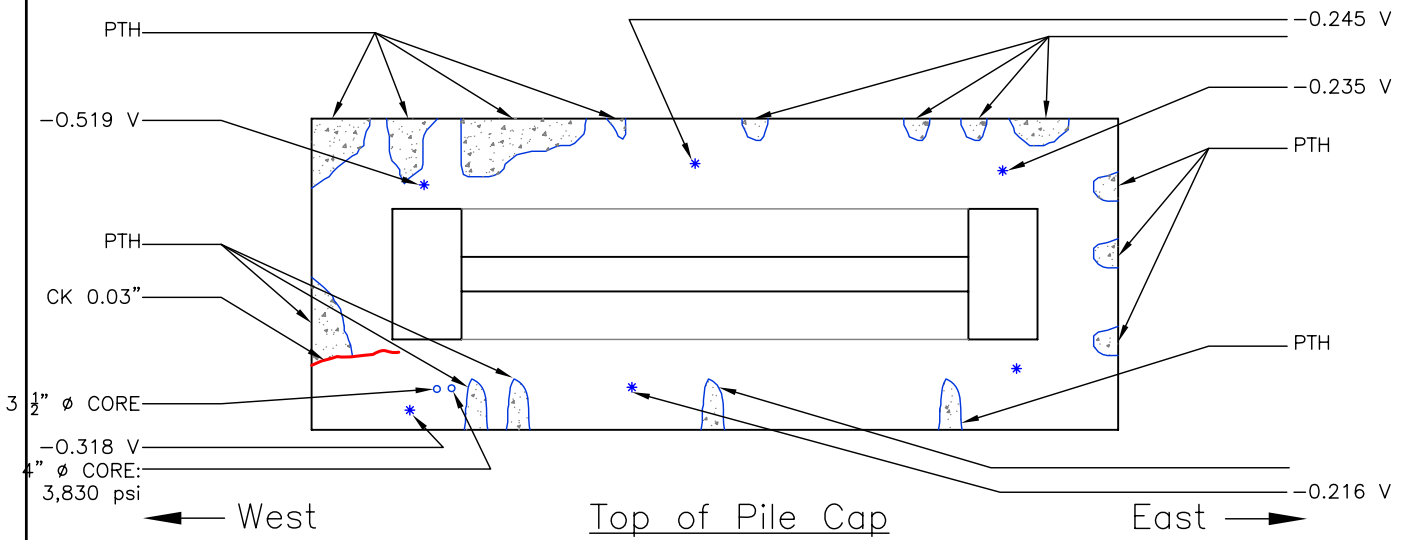
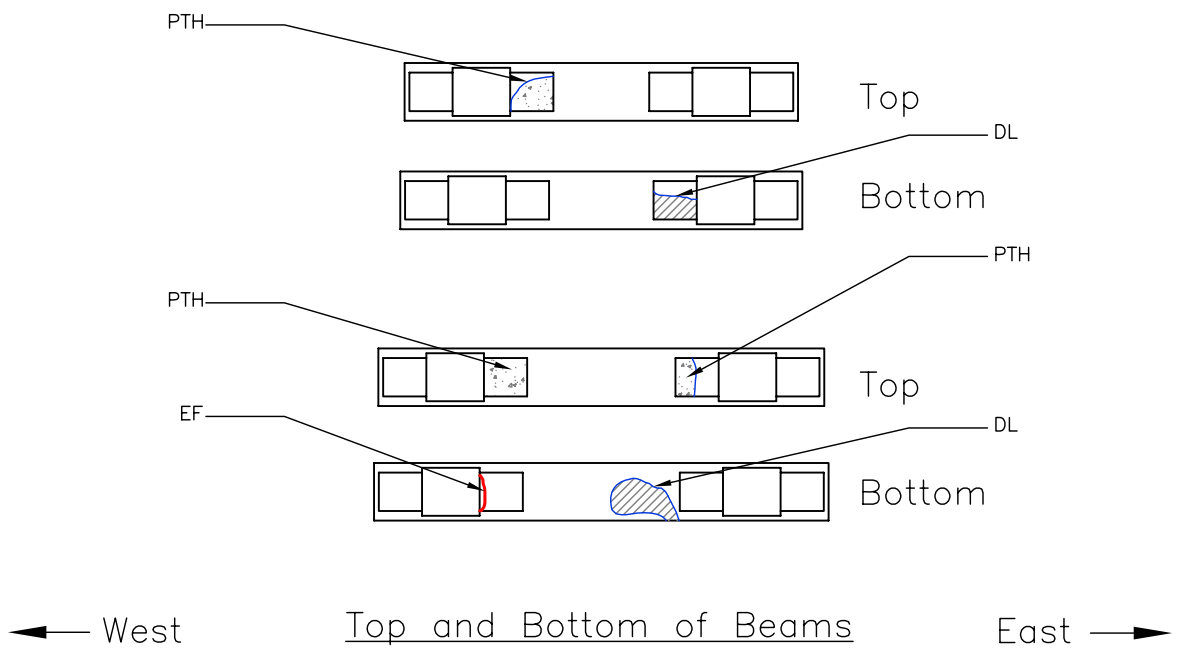
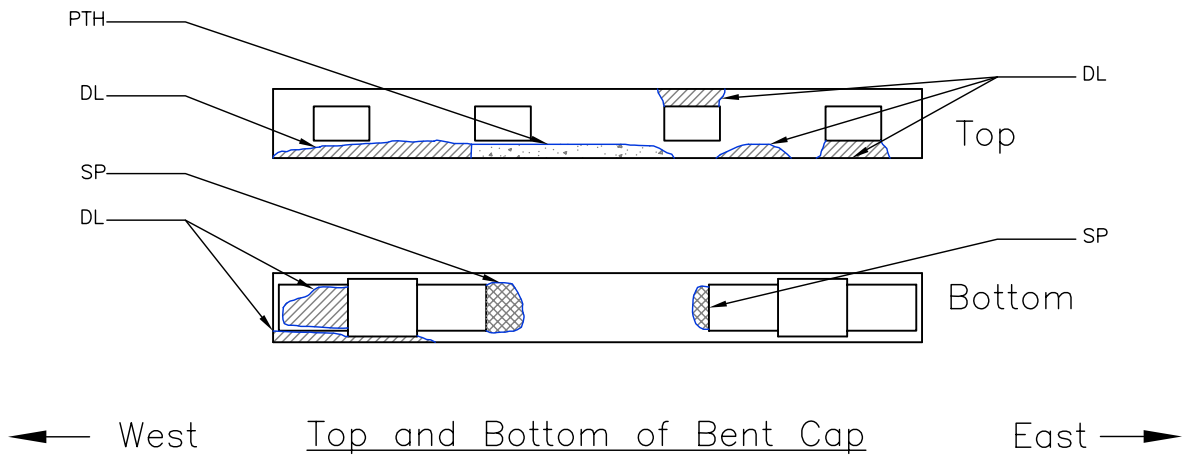

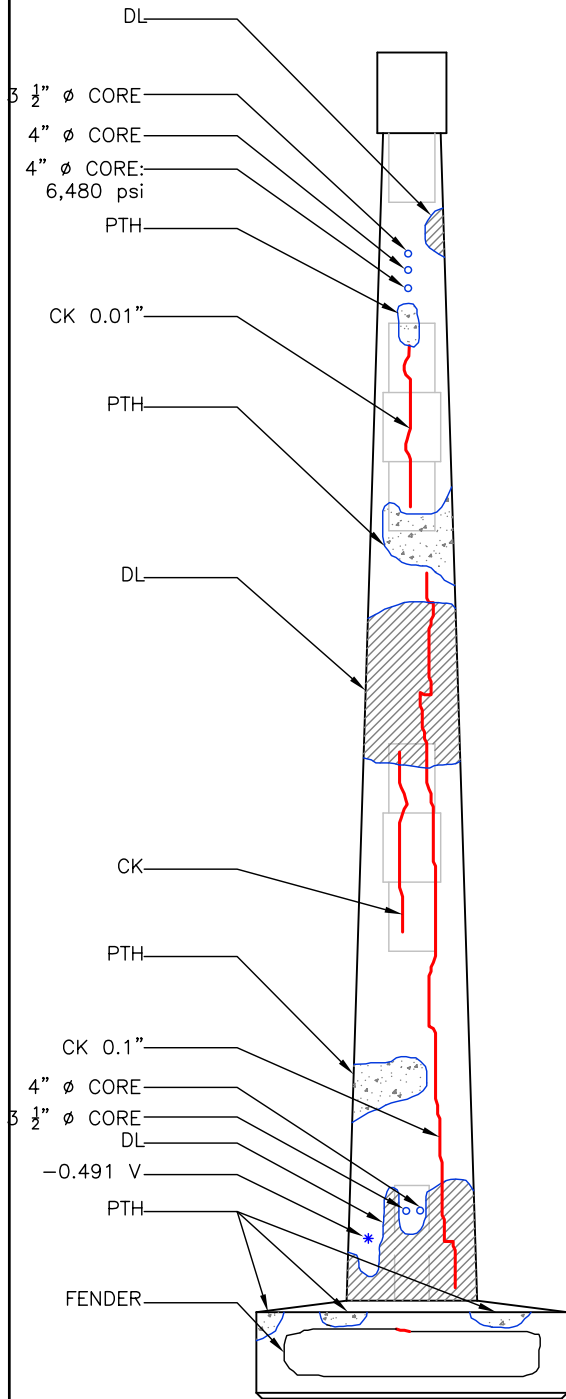

West Ext. Side

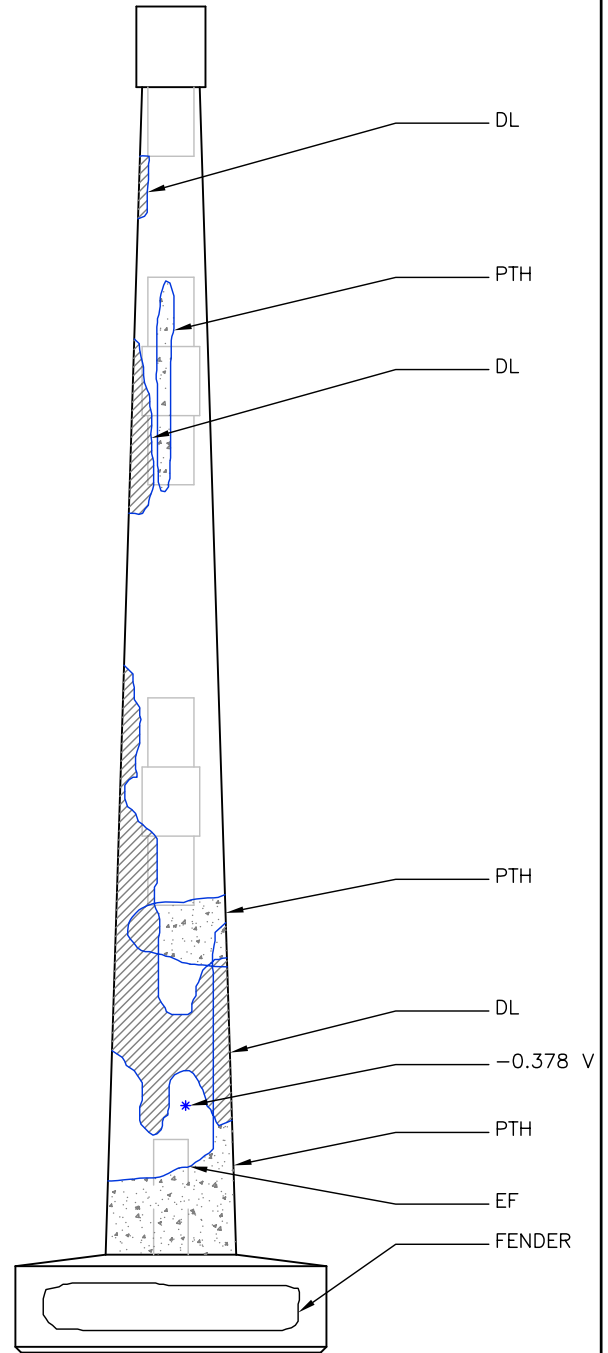

East Ext. Side

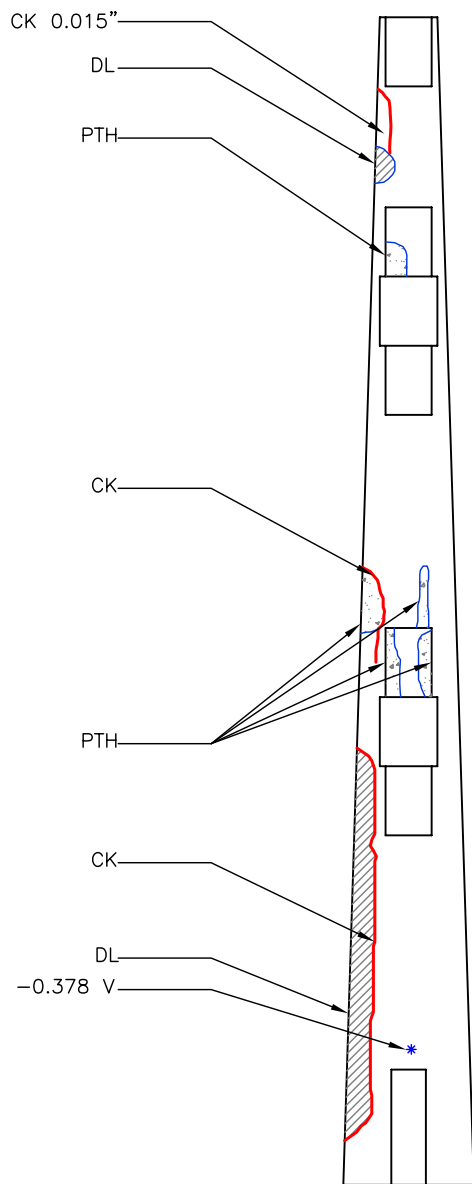

West Int. Side

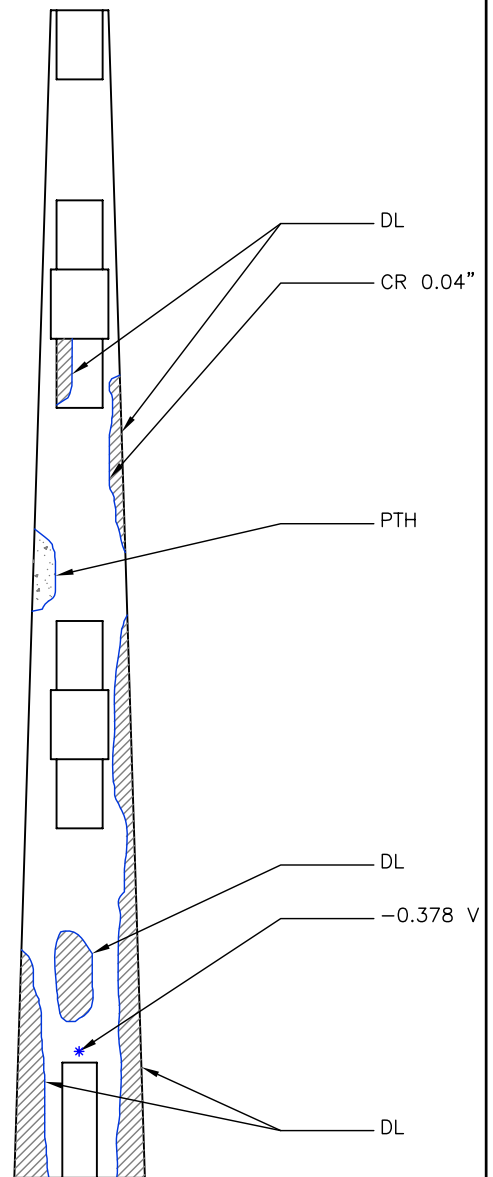

East Int. Side

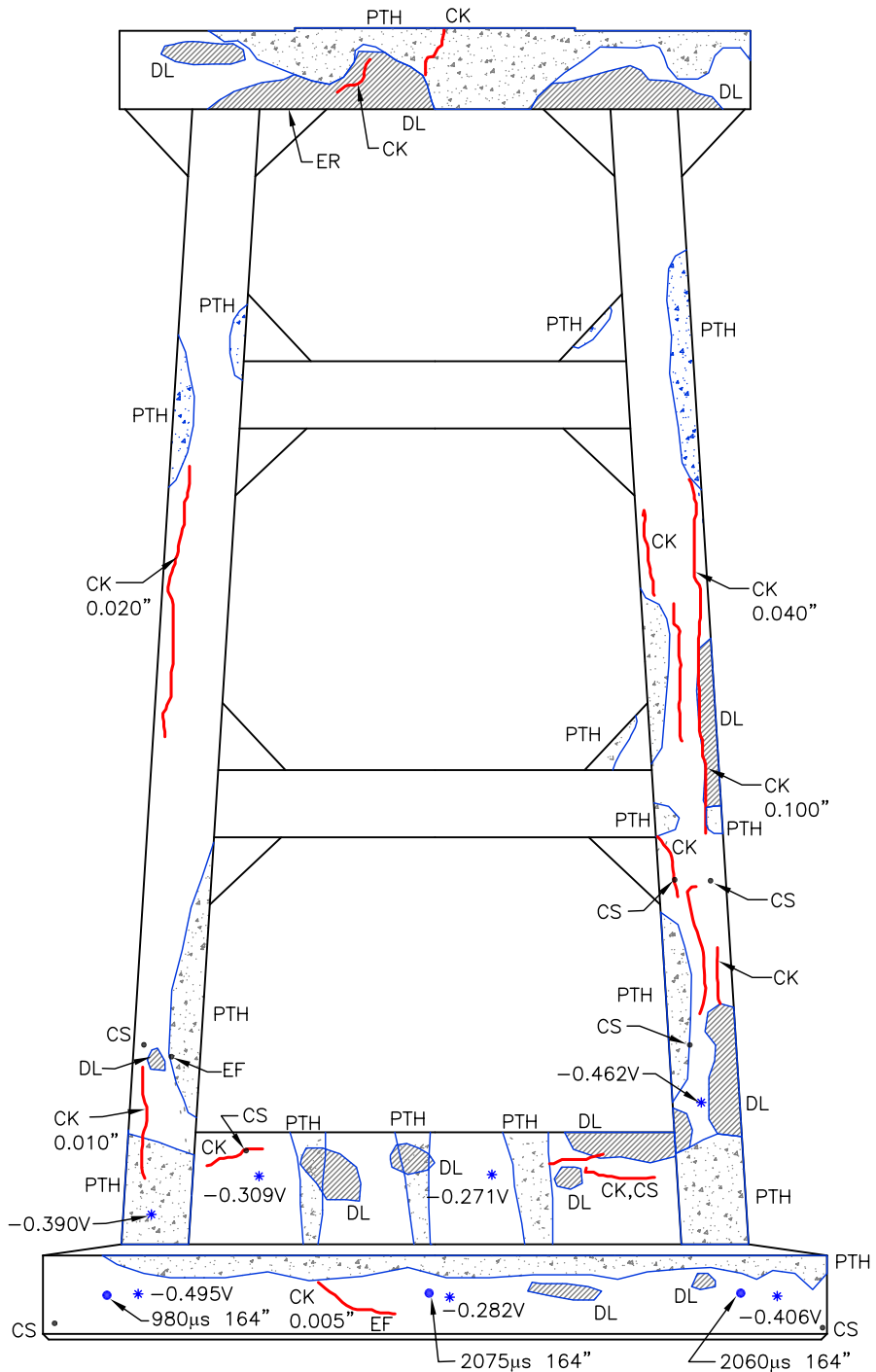

North Elevation

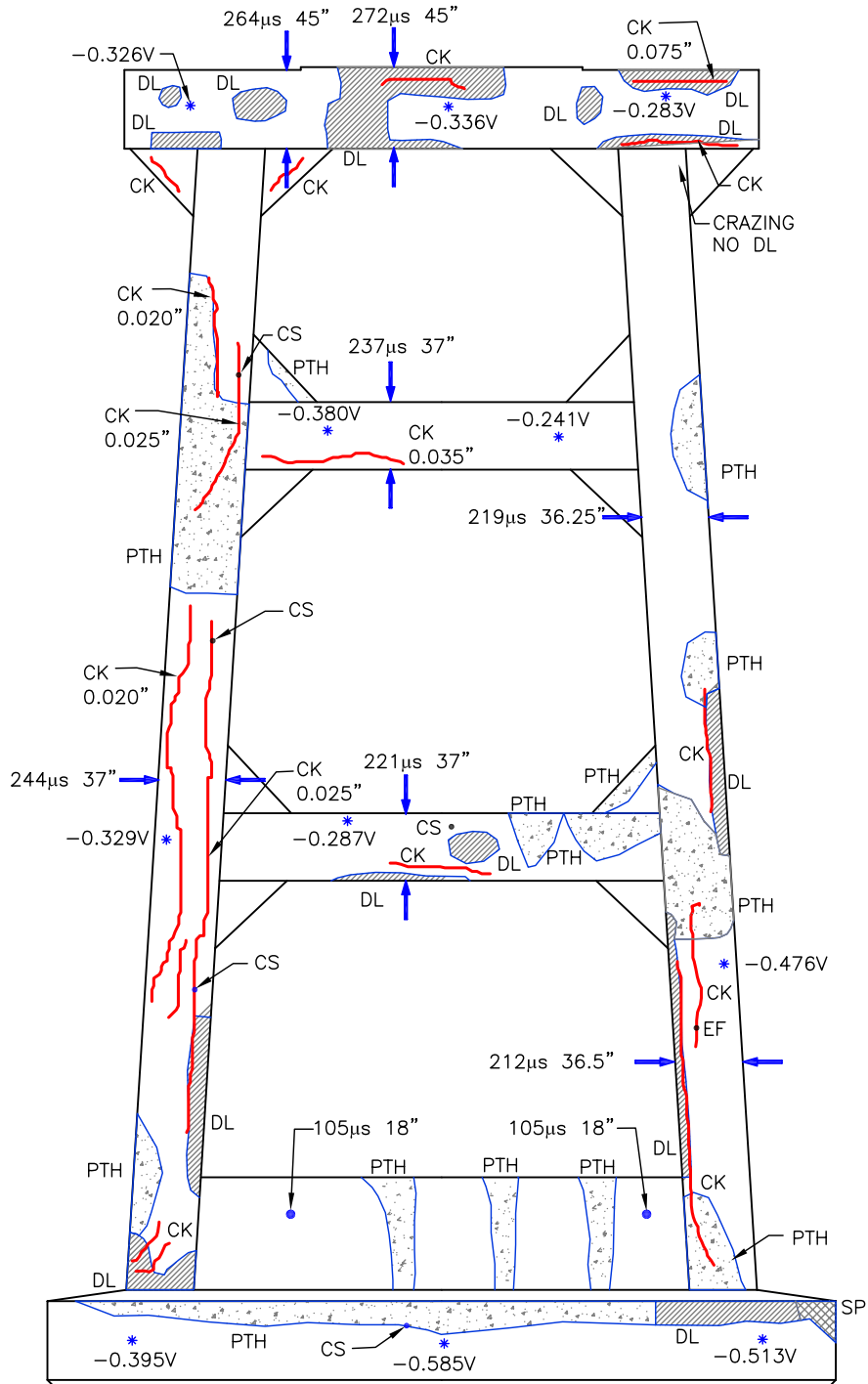

South Elevation

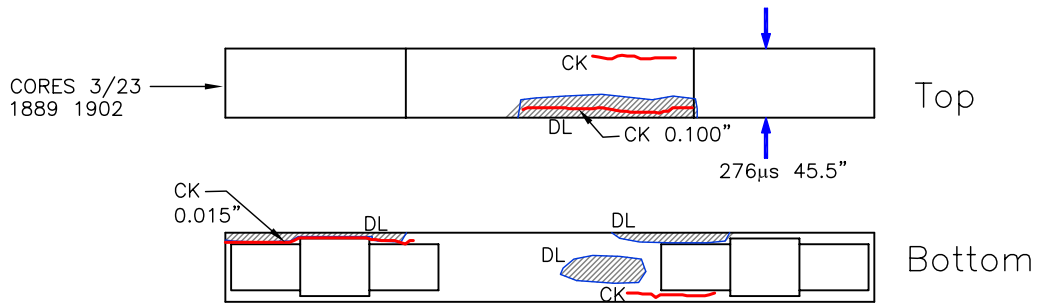

West ← Top and Bottom of Bent Cap → East

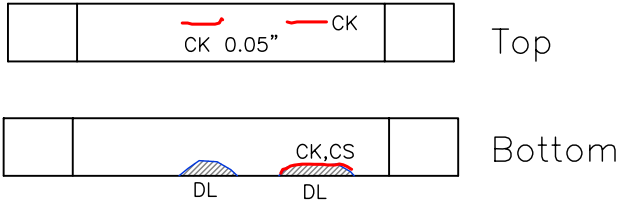
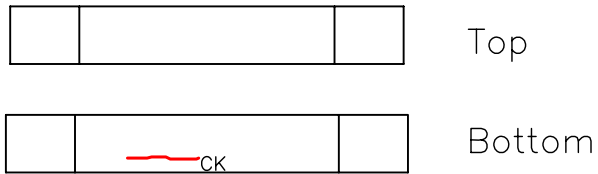

West ← Top and Bottom of Beams → East

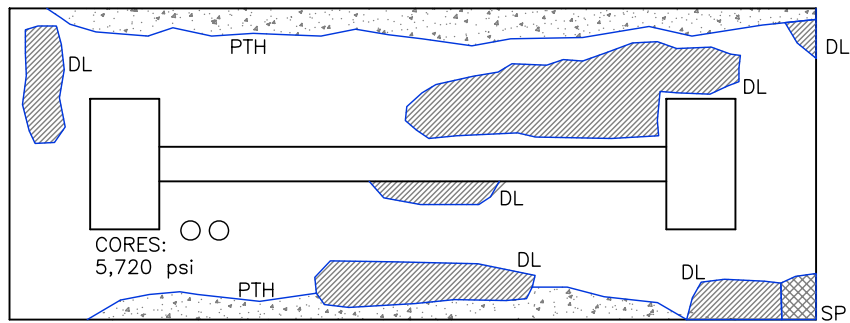

West ← Top of Pile Cap → East

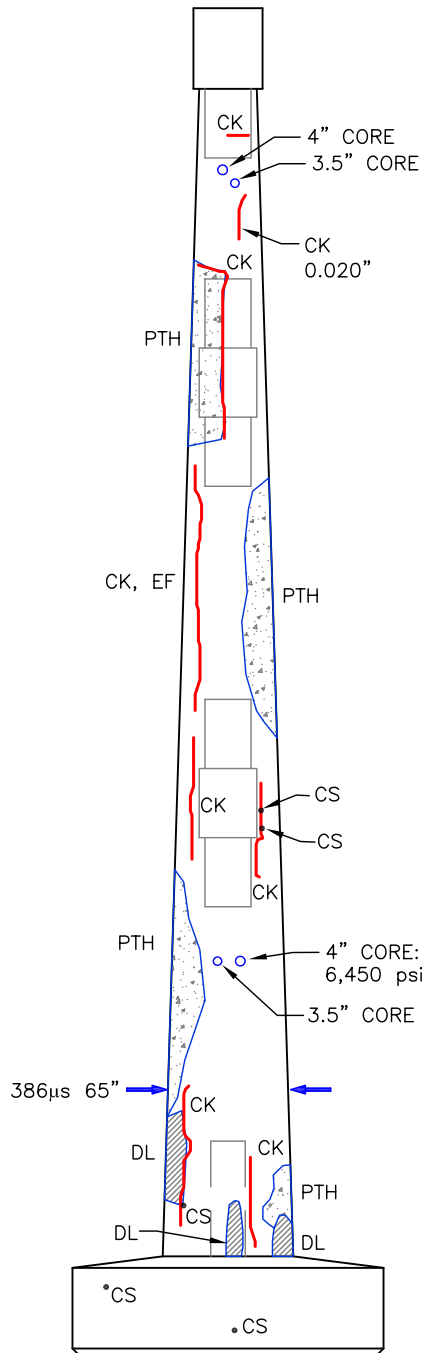

West Ext. Side

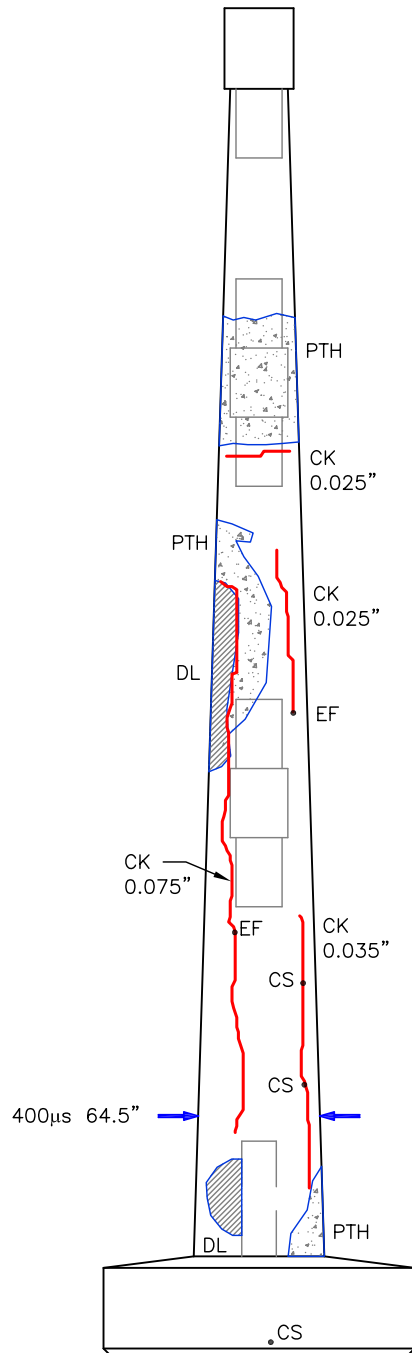

East Ext. Side

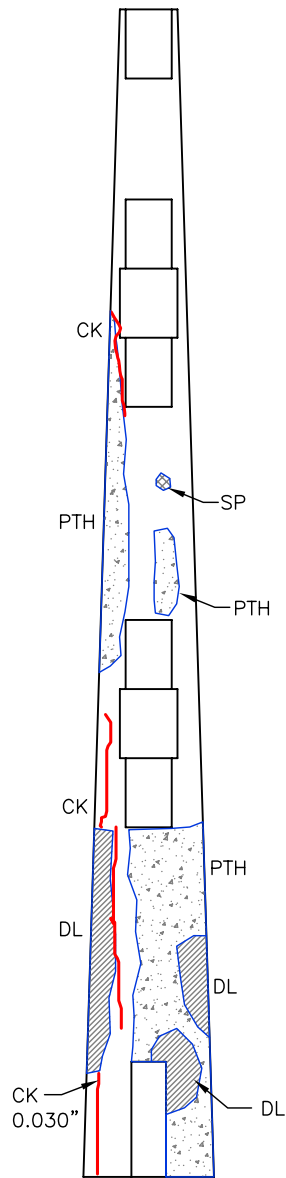

West Int. Side

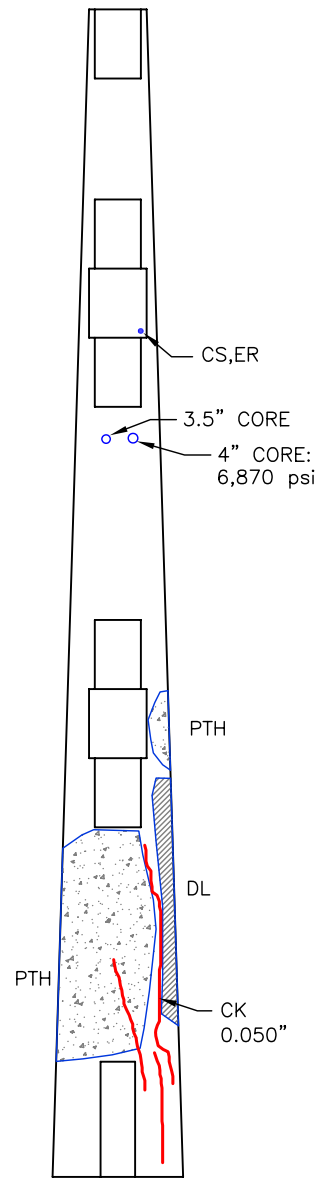

East Int. Side



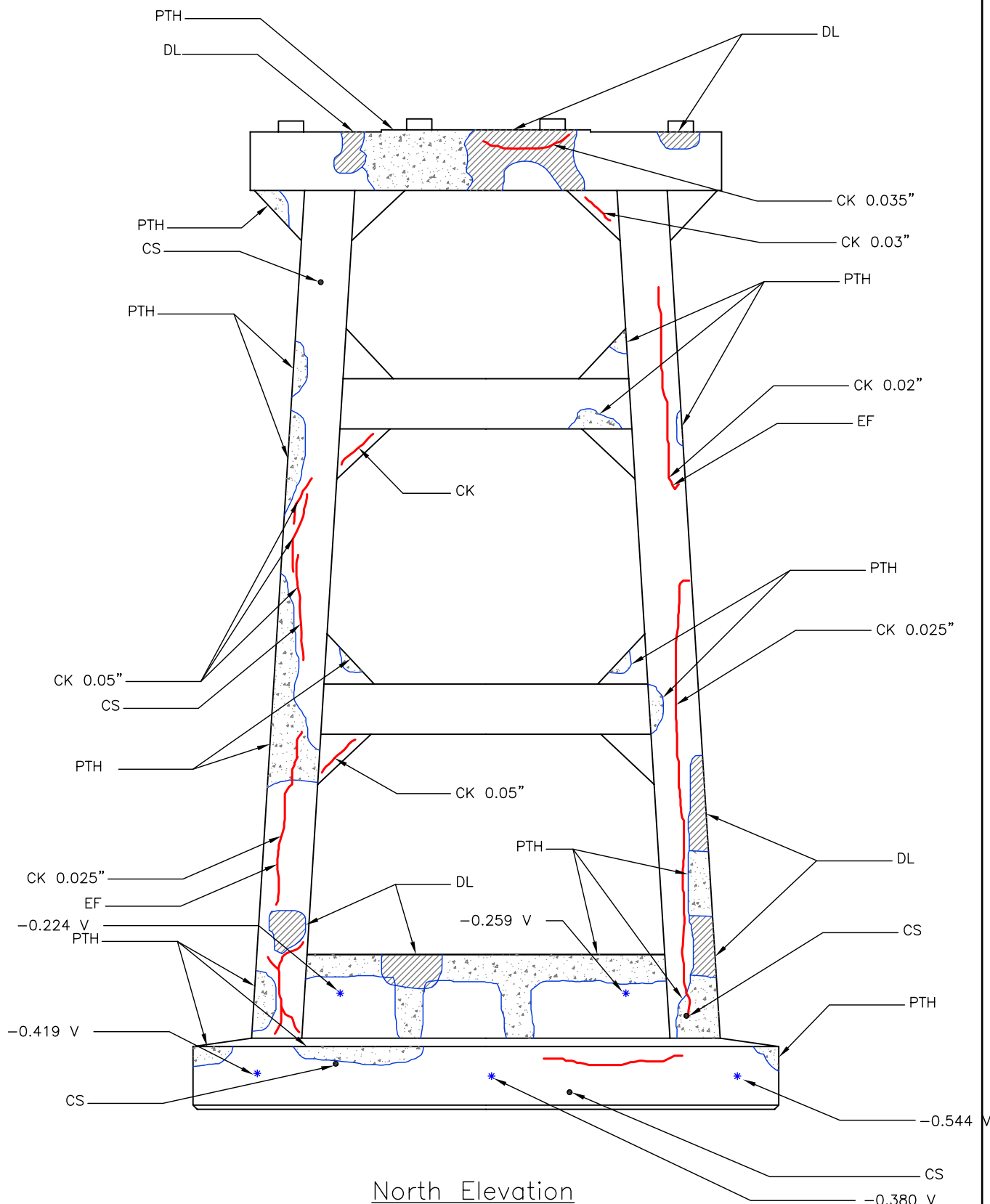

North Elevation

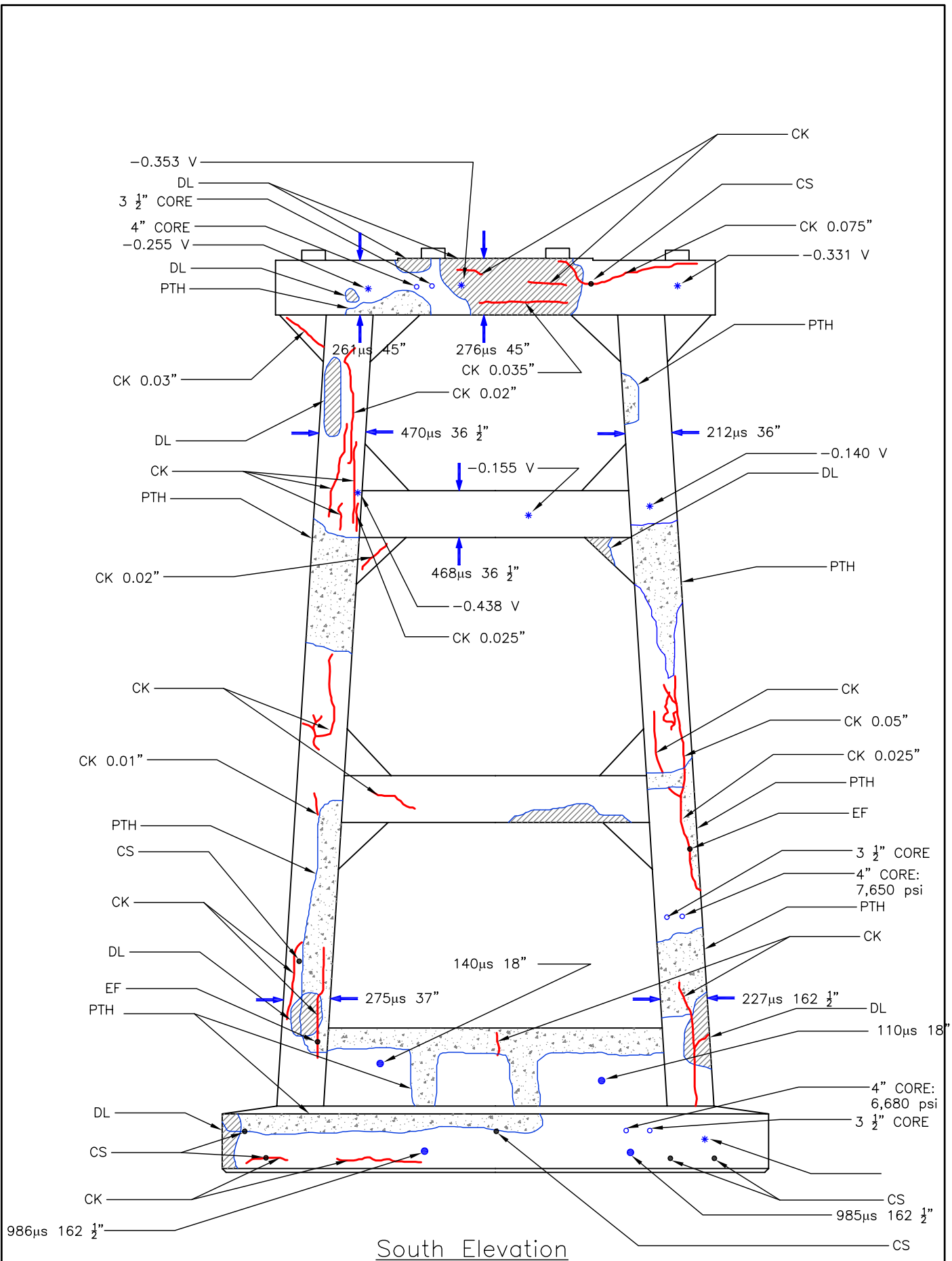

South Elevation

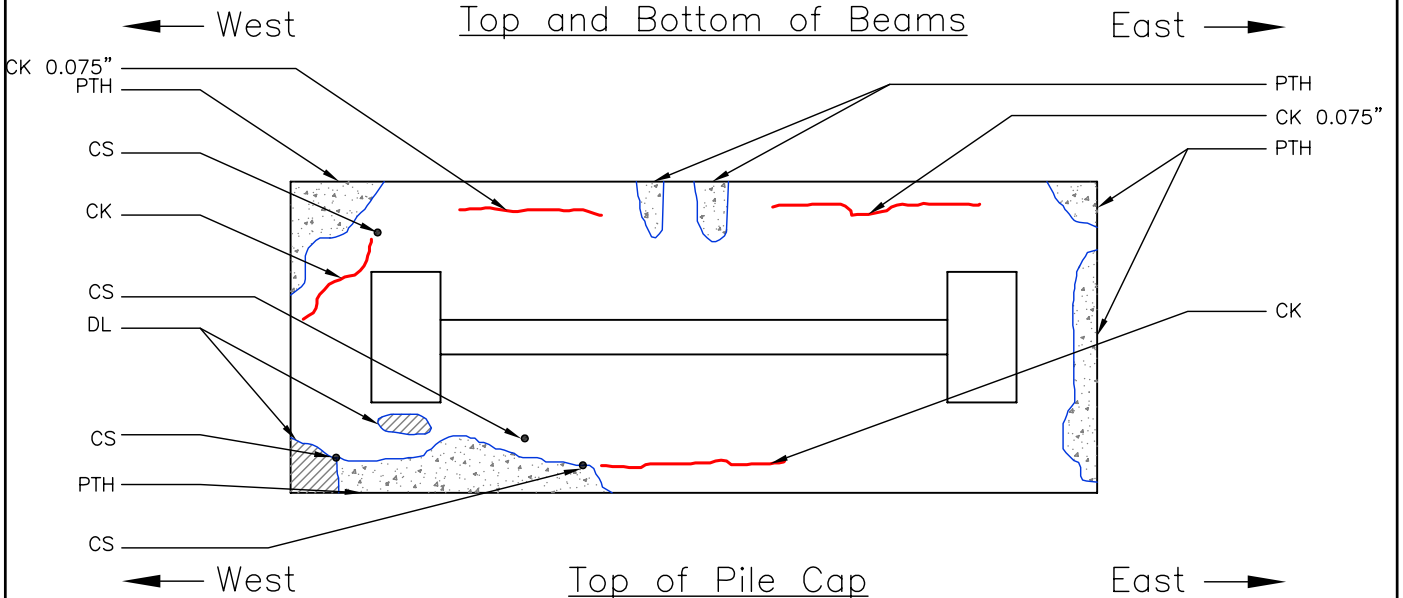
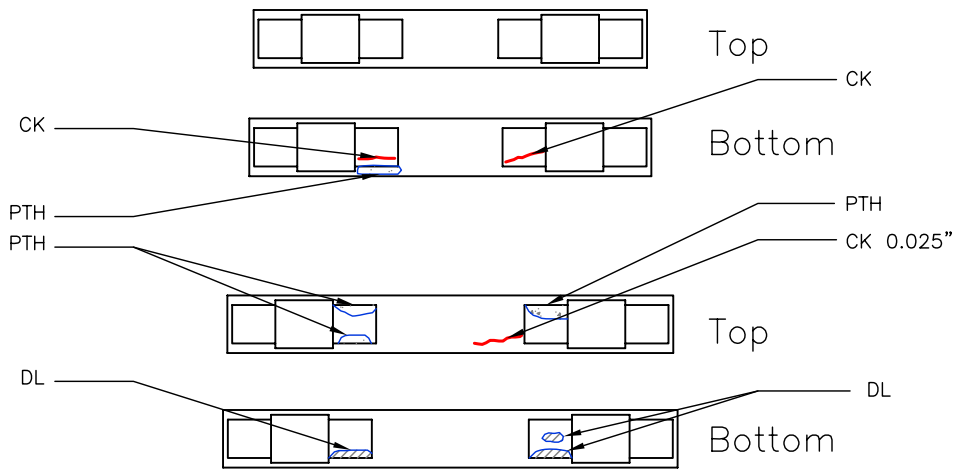
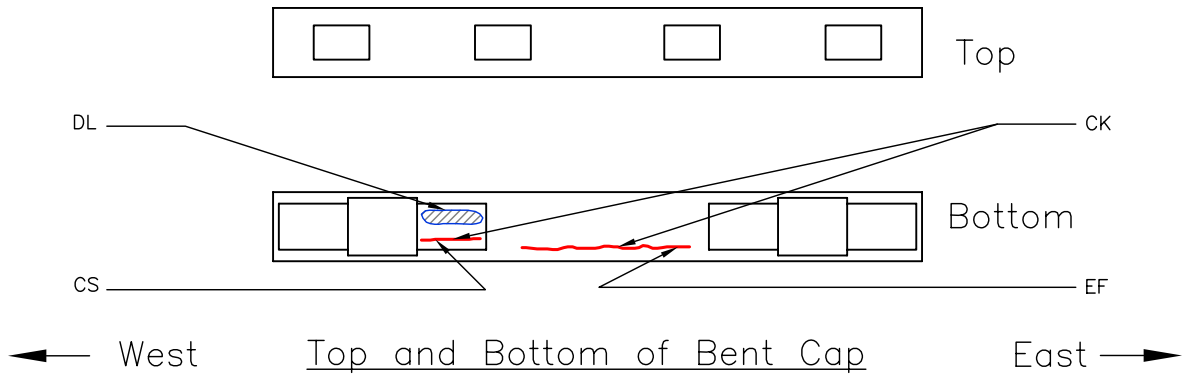

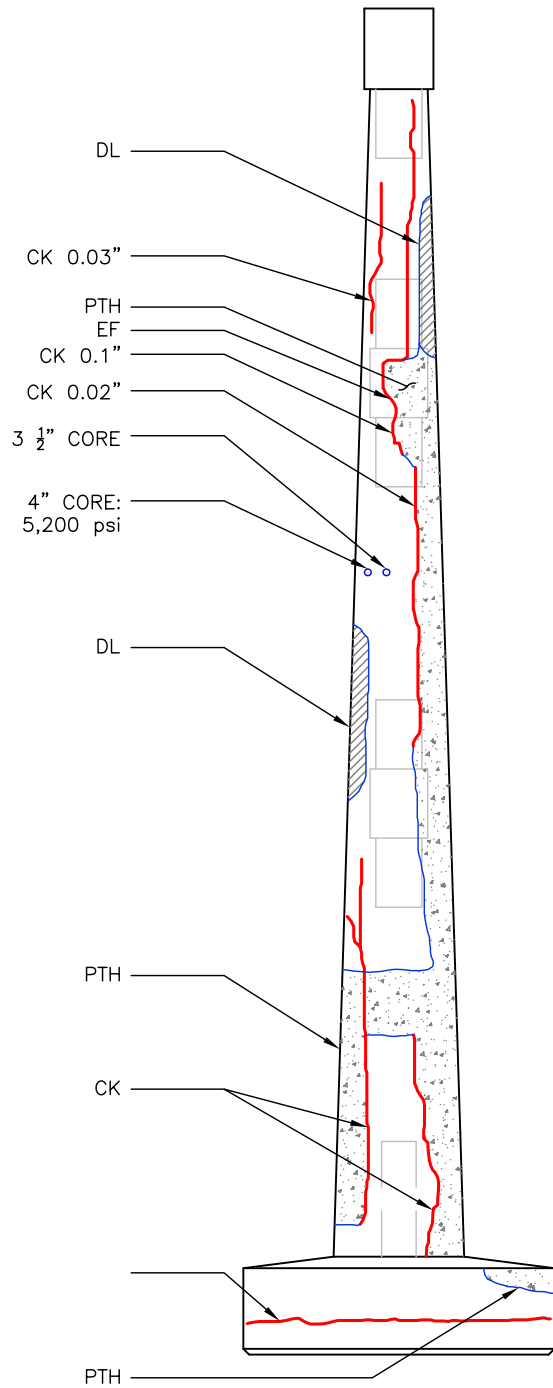

West Ext. Side

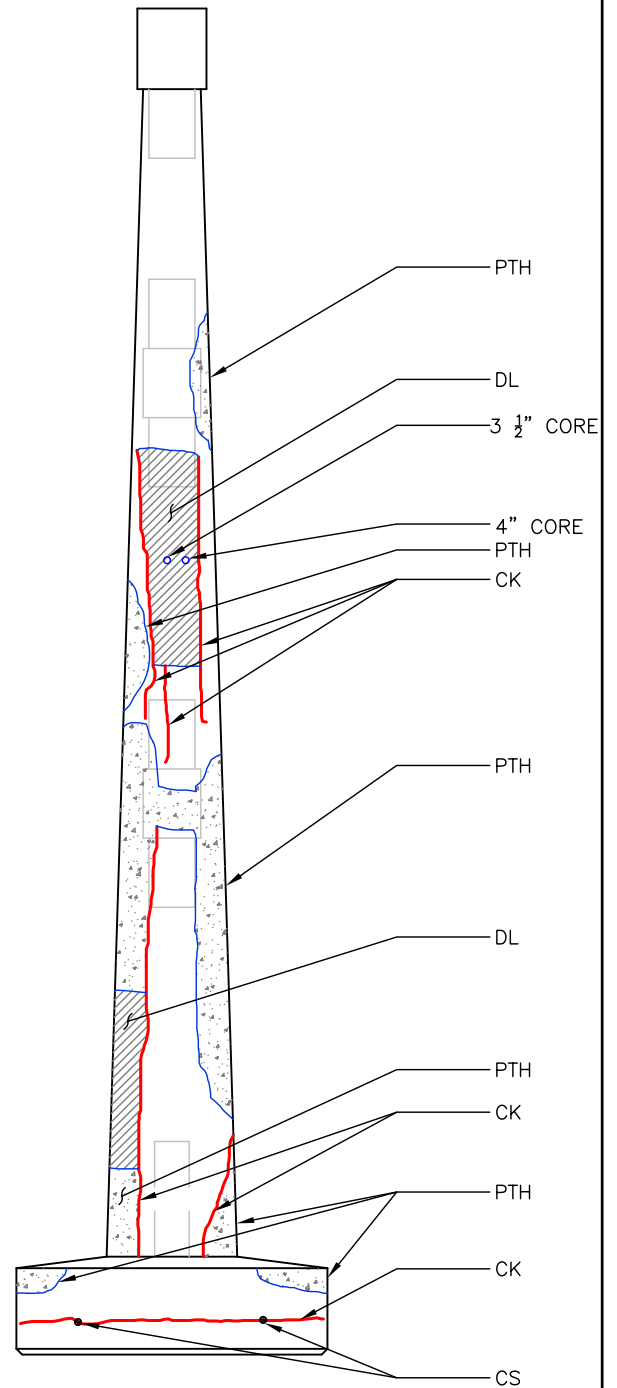

East Ext. Side

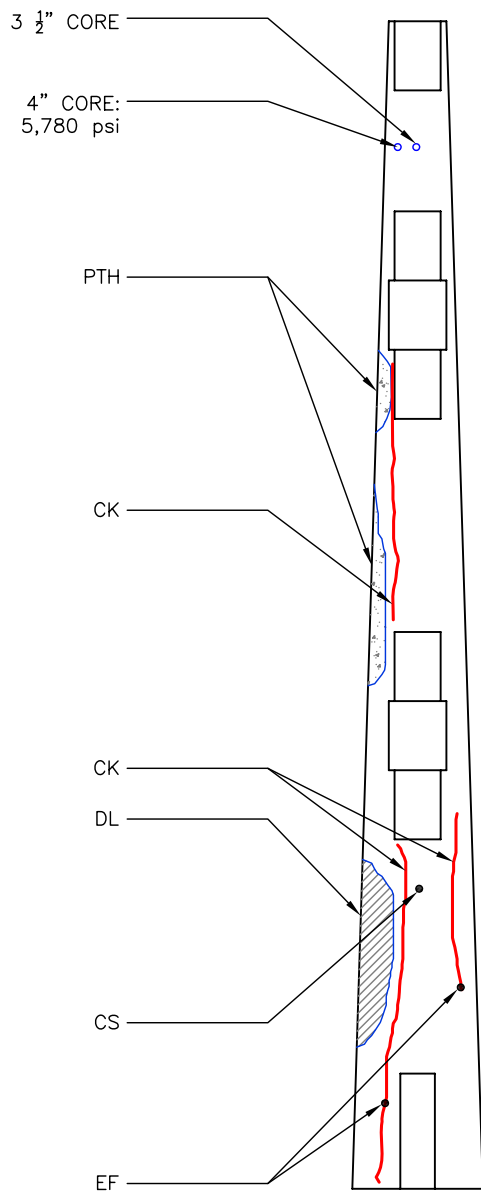

West Int. Side

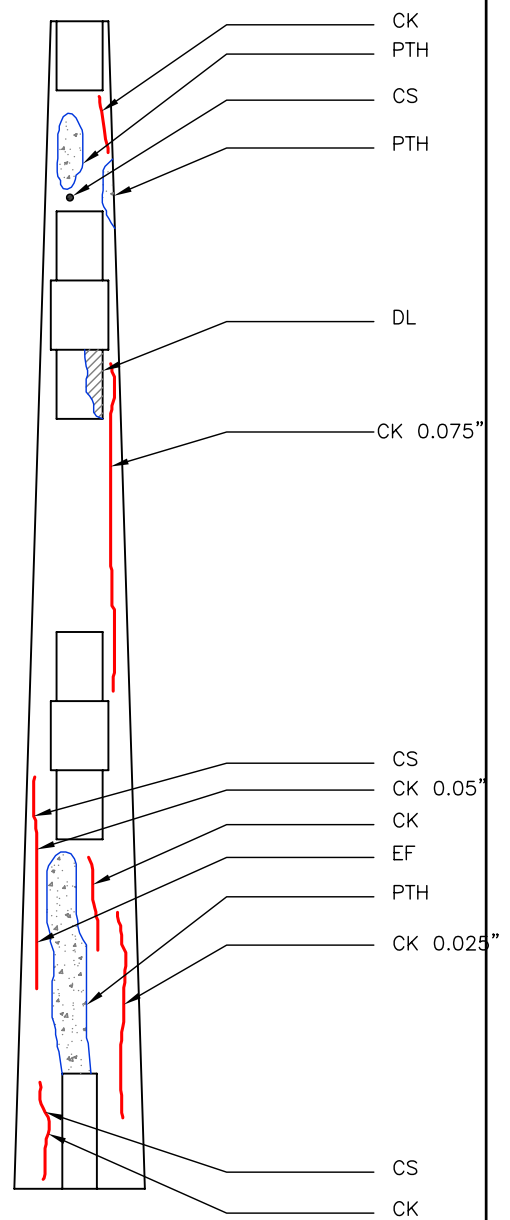

East Int. Side

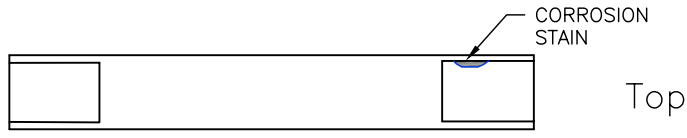

Top of Middle Beam

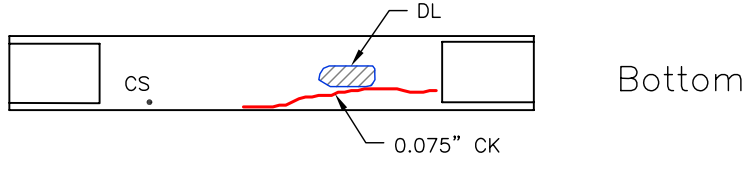

West ← → East

Bottom of Middle Beam

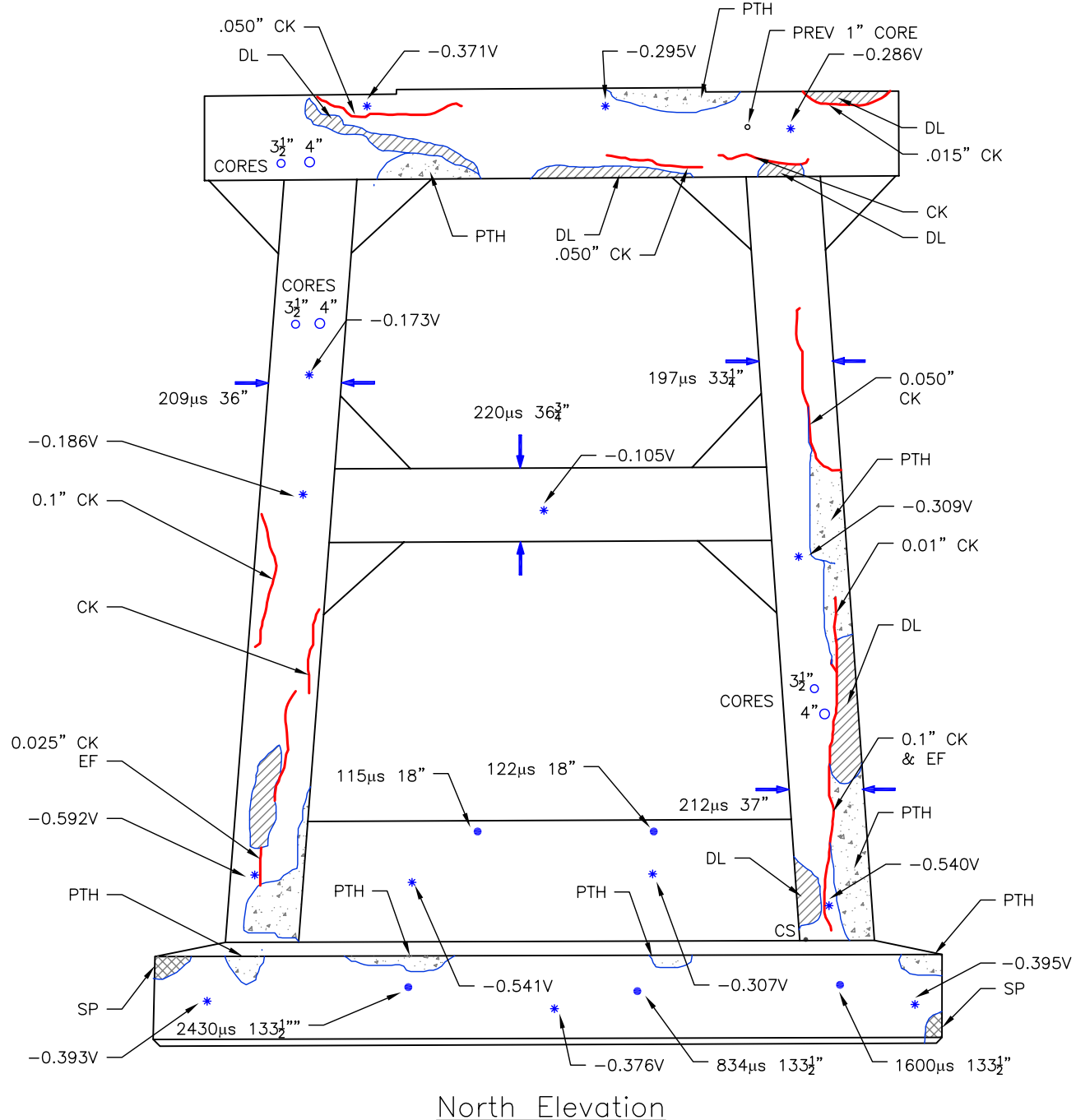

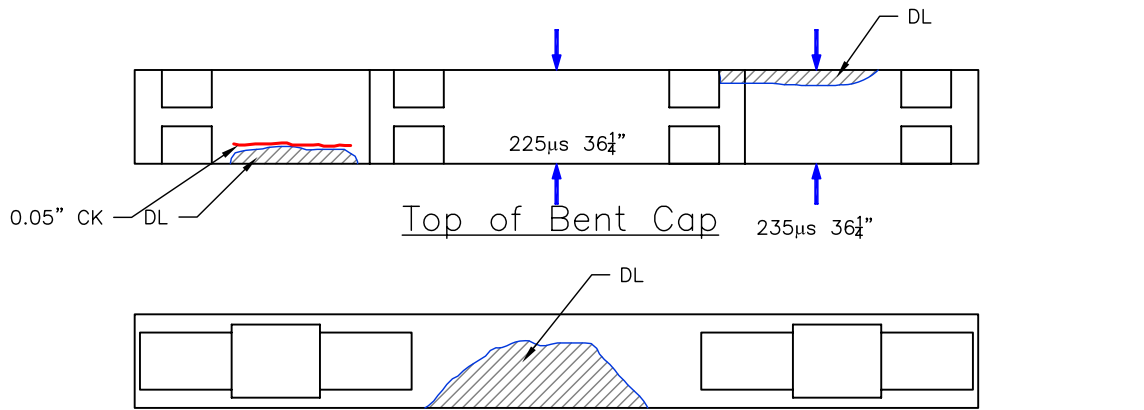

Bottom of Bent Cap

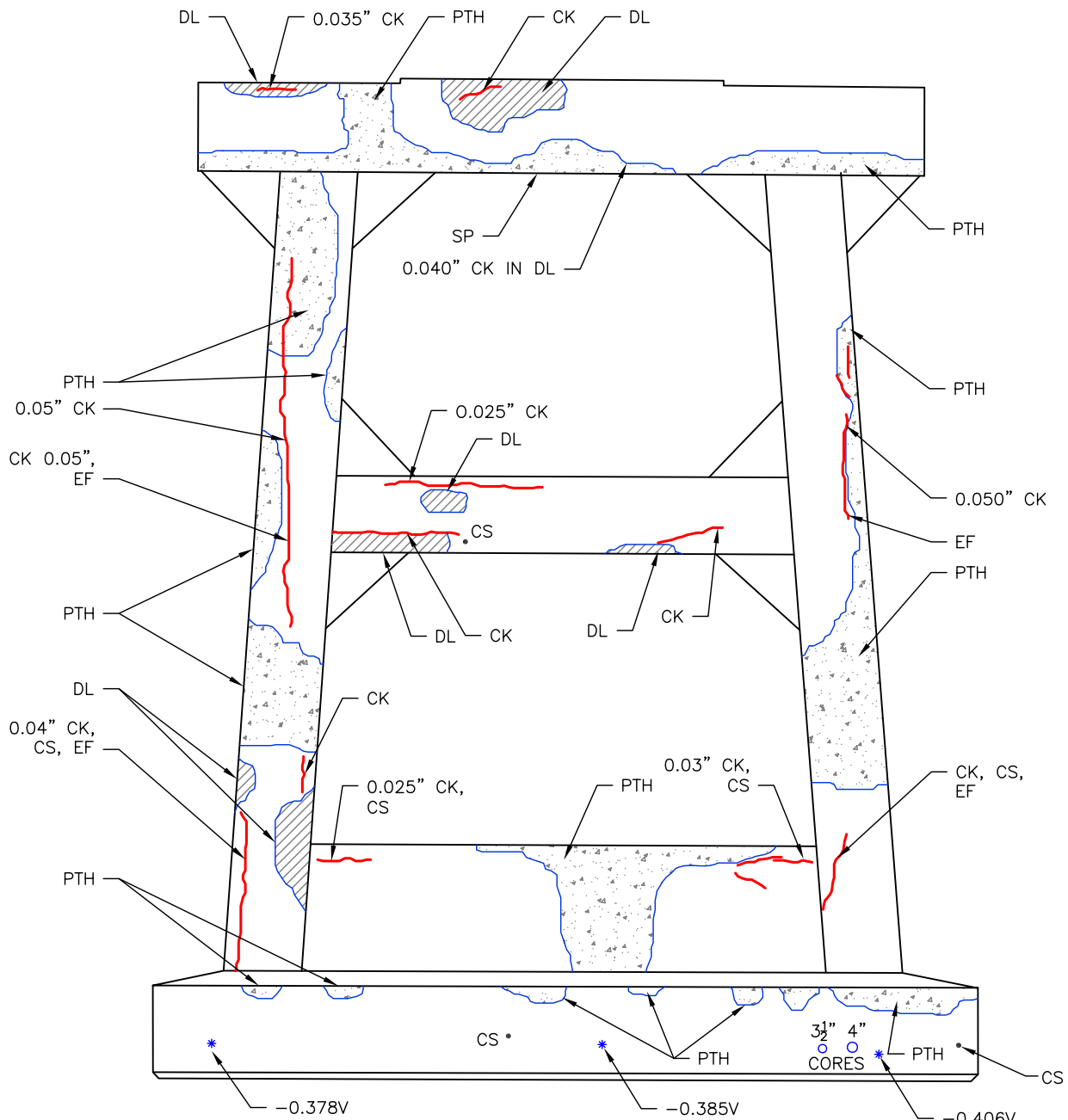

South Elevation

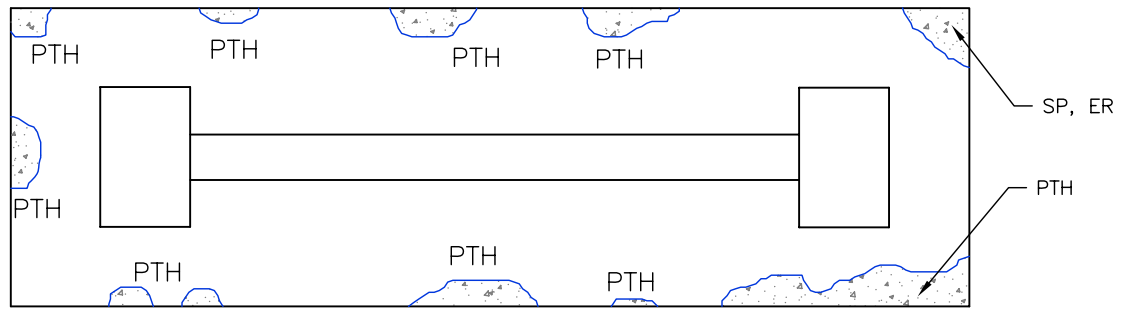

West

Top of Pile Cap

East

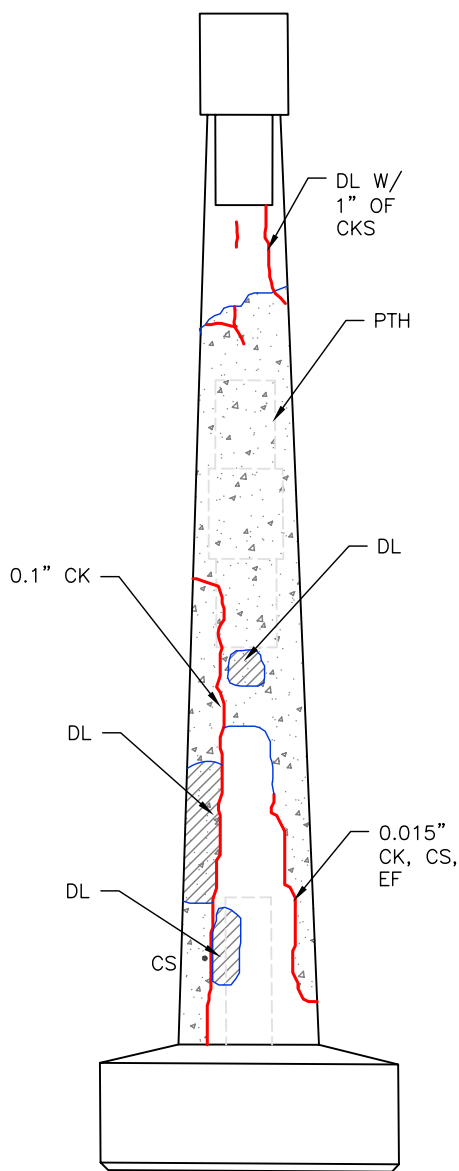

West Ext. Side

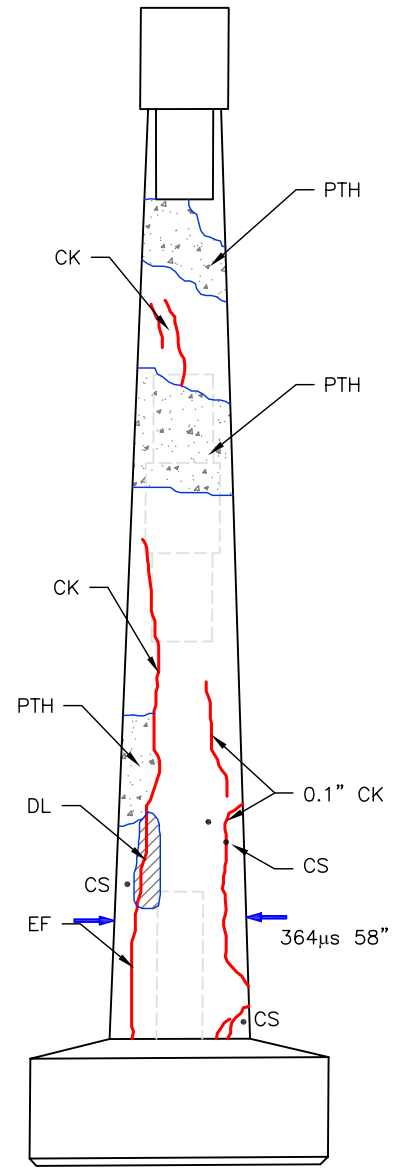

East Ext. Side



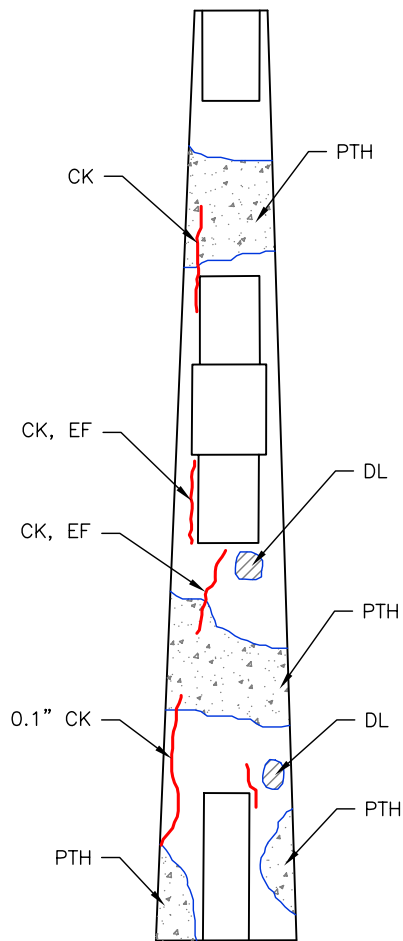

West Int. Side

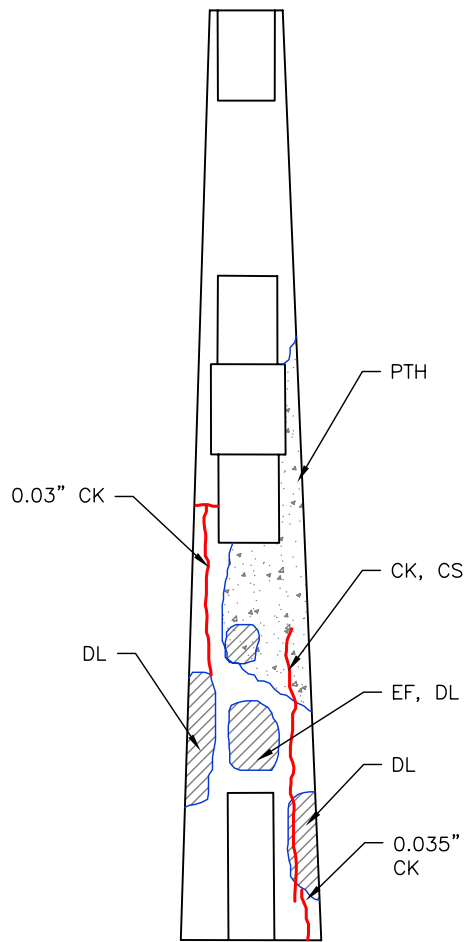

East Int. Side

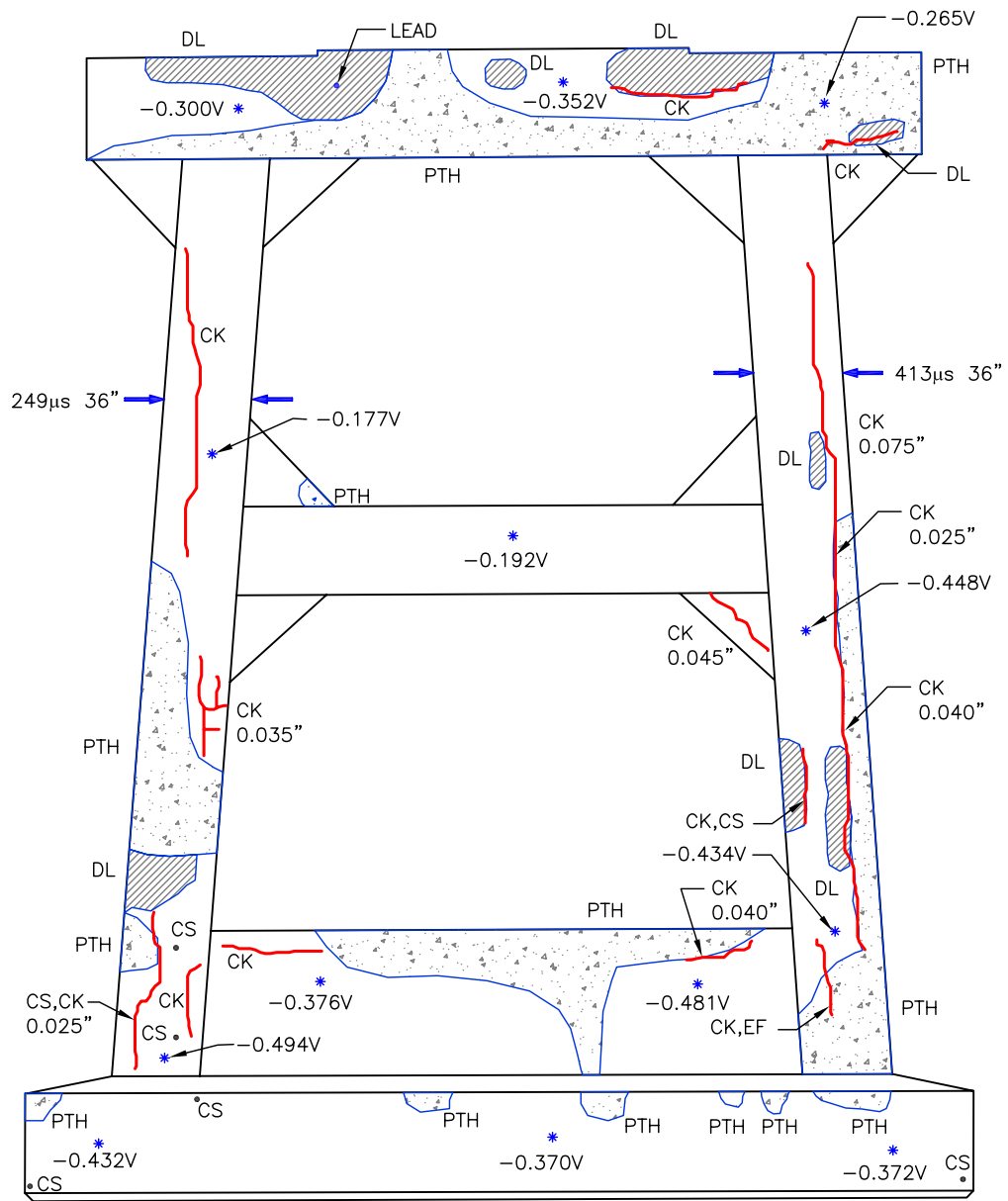
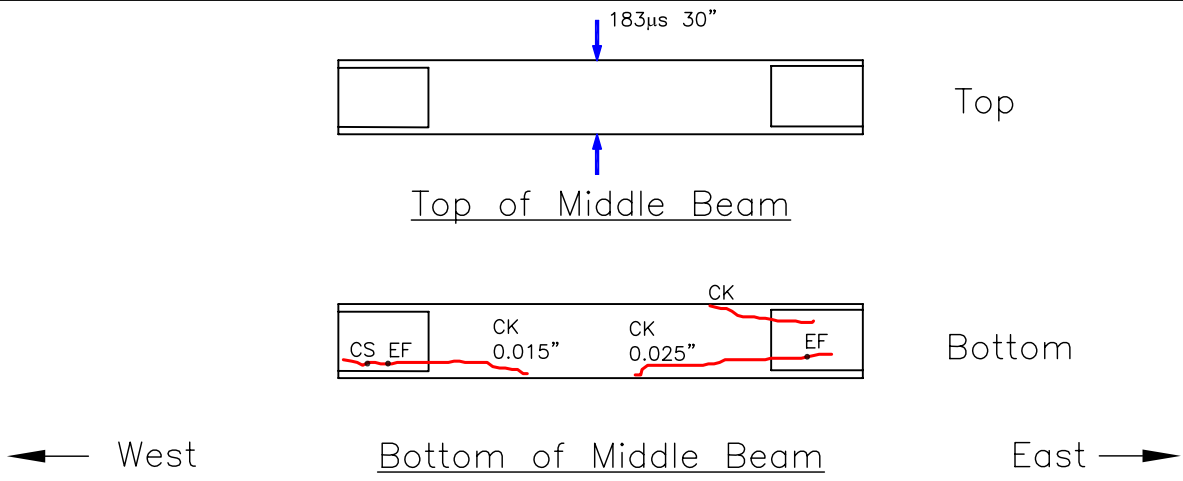

North Elevation

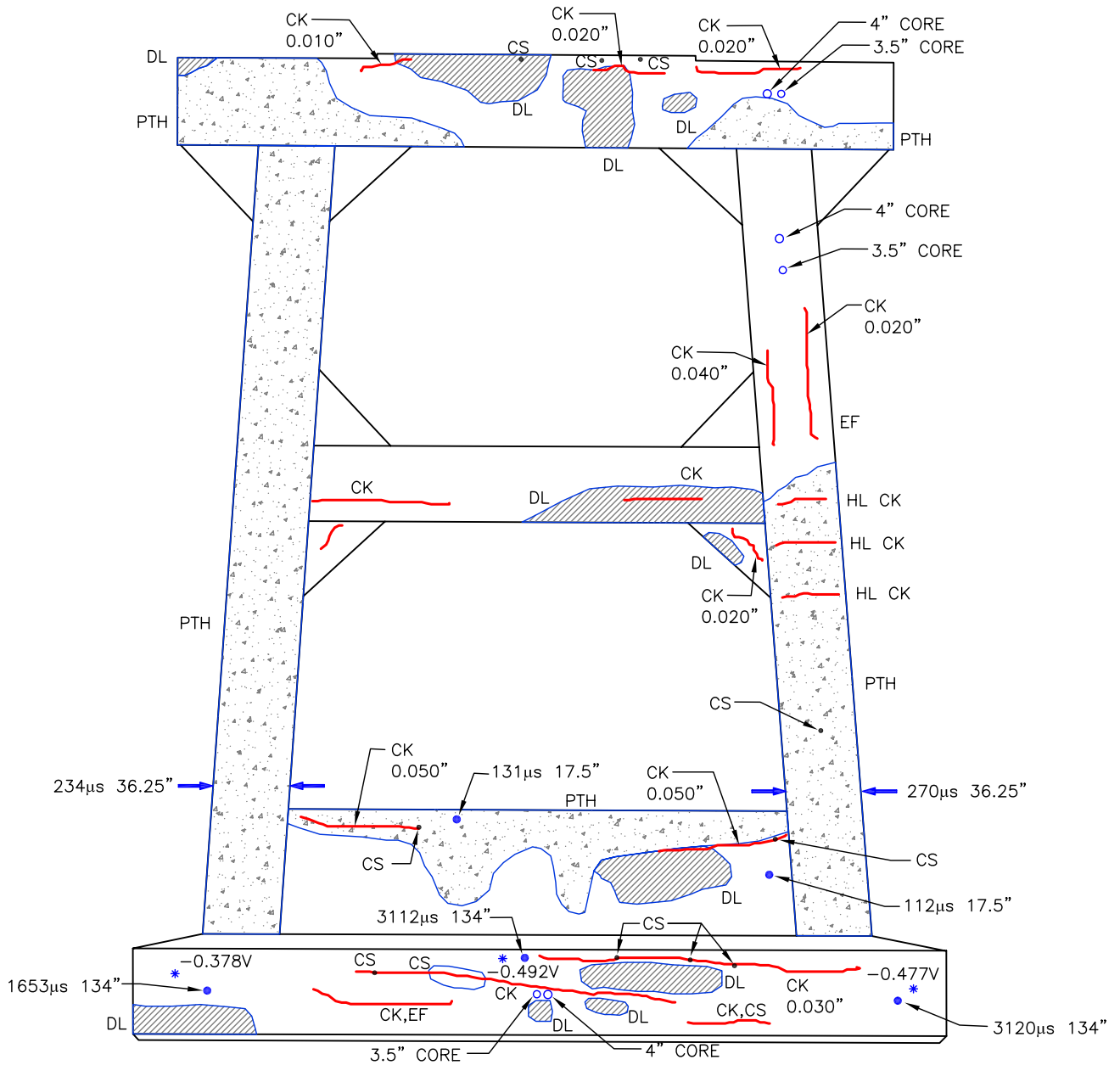
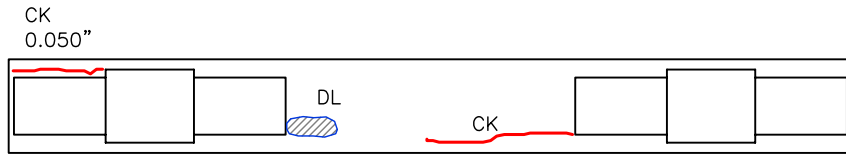
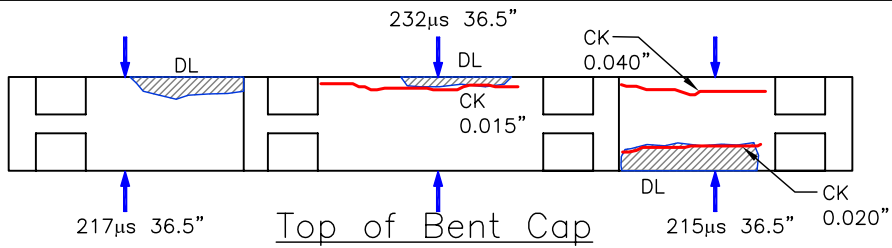

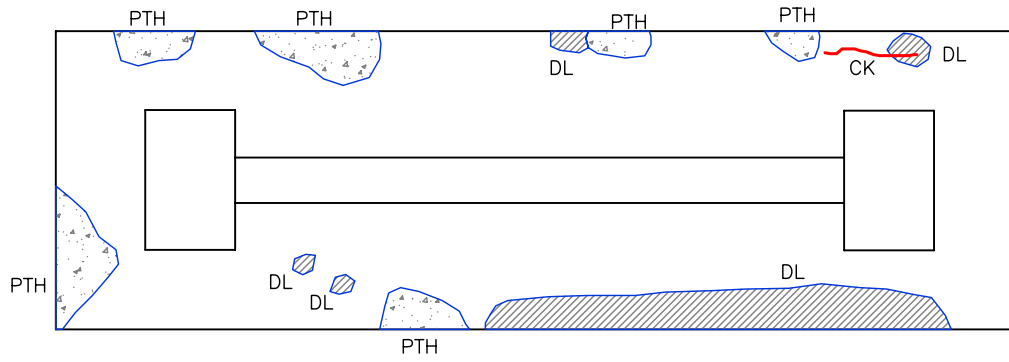

West

Top of Pile Cap

East

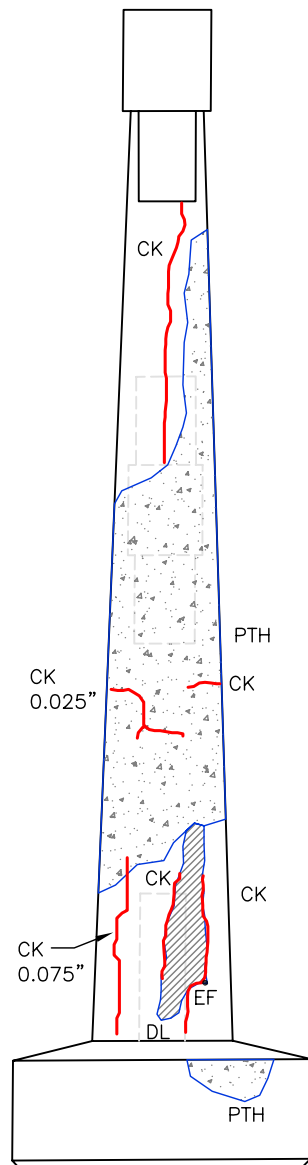

West Ext. Side

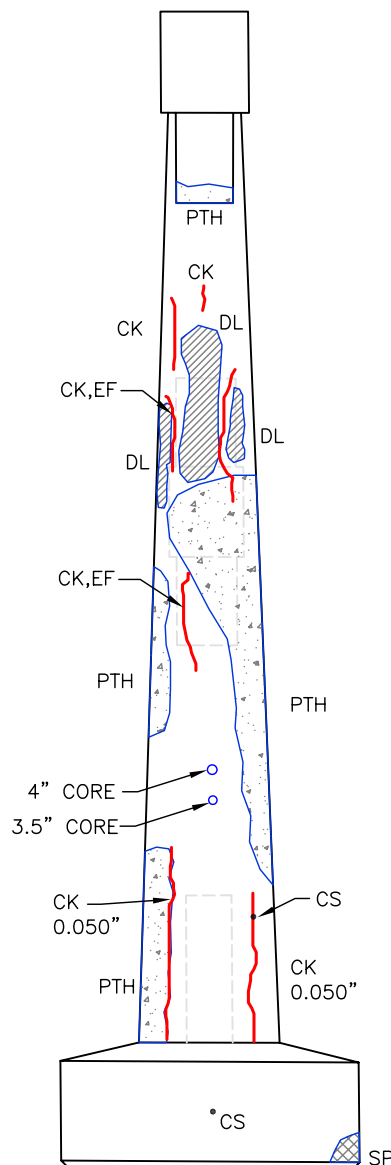

East Ext. Side

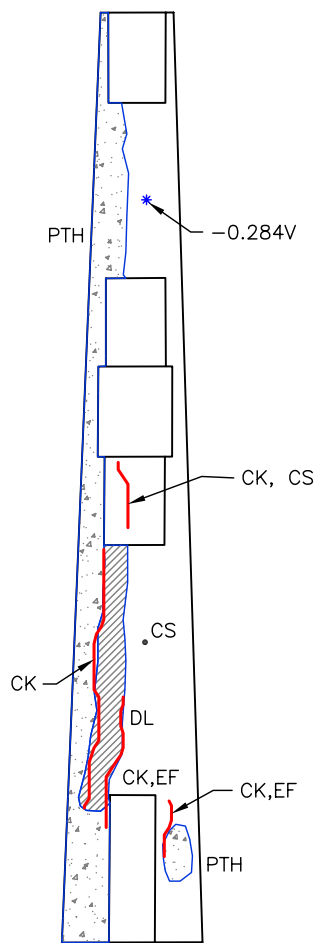

West Int. Side

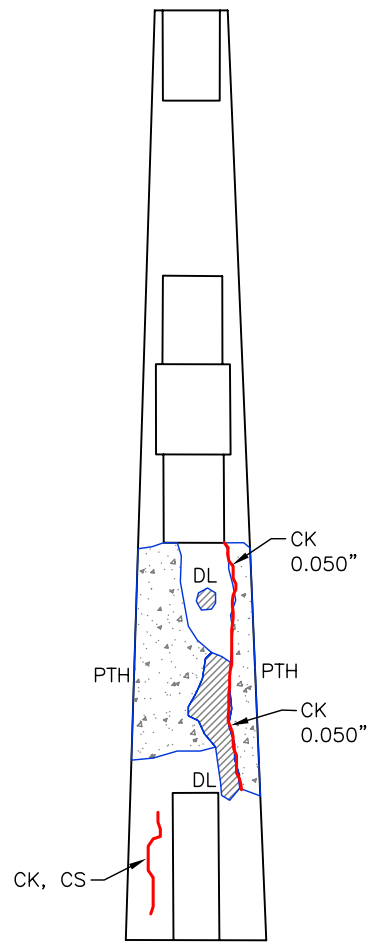

East Int. Side

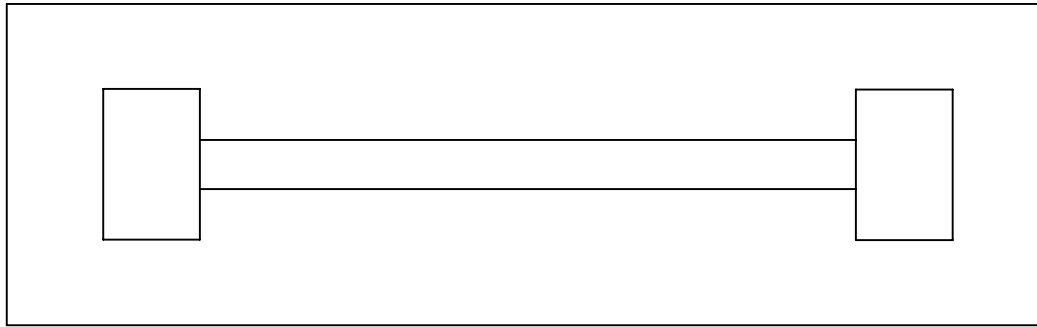

Top of Pile Cap

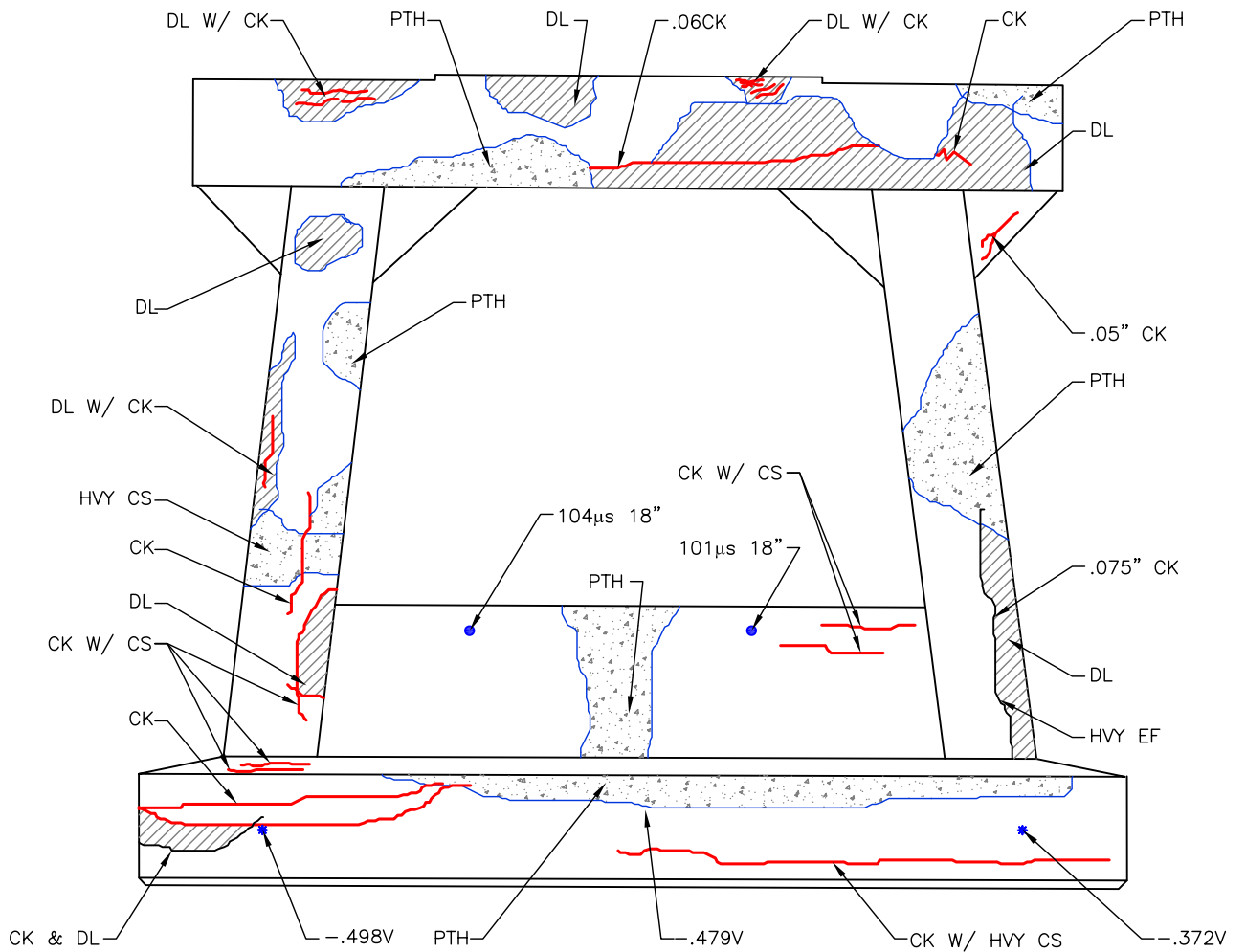

North Elevation

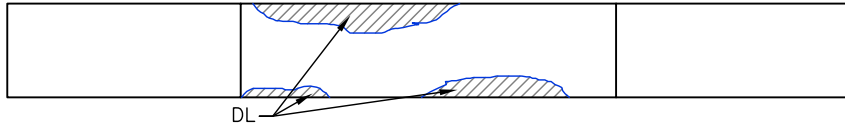

Top of Bent Cap

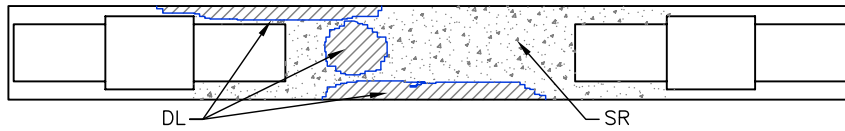

Bottom of Bent Cap

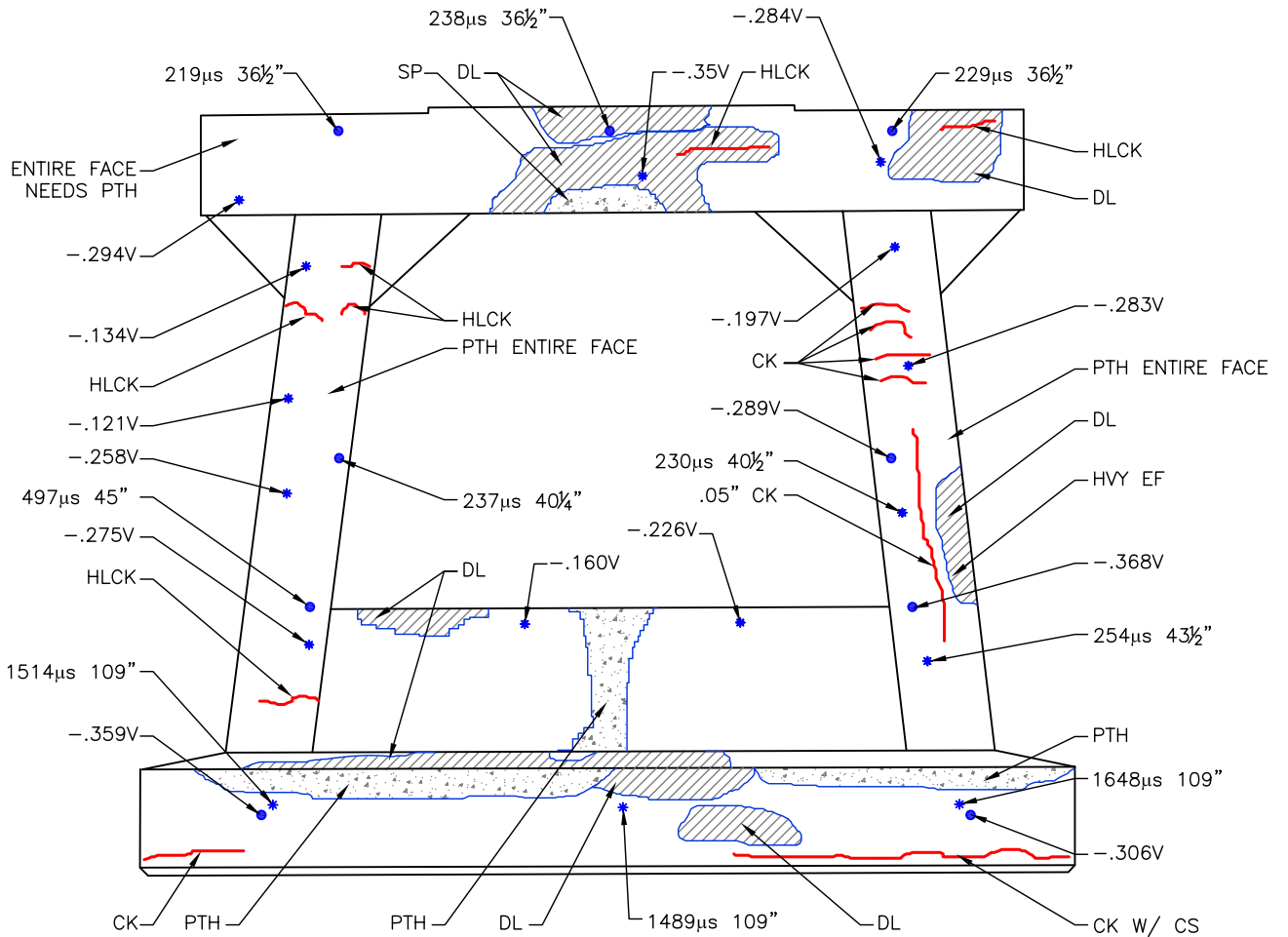

South Elevation

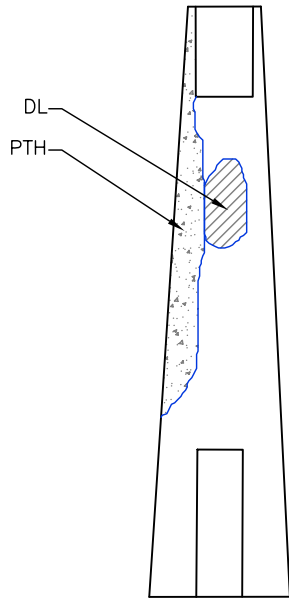

West Int. Side

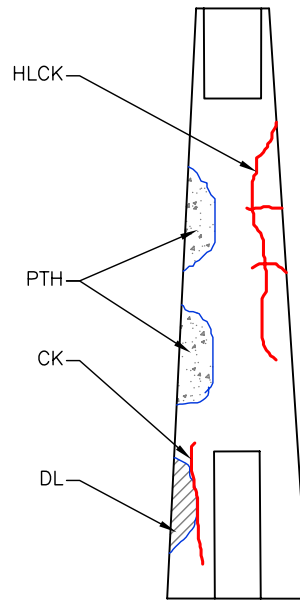

East Int. Side

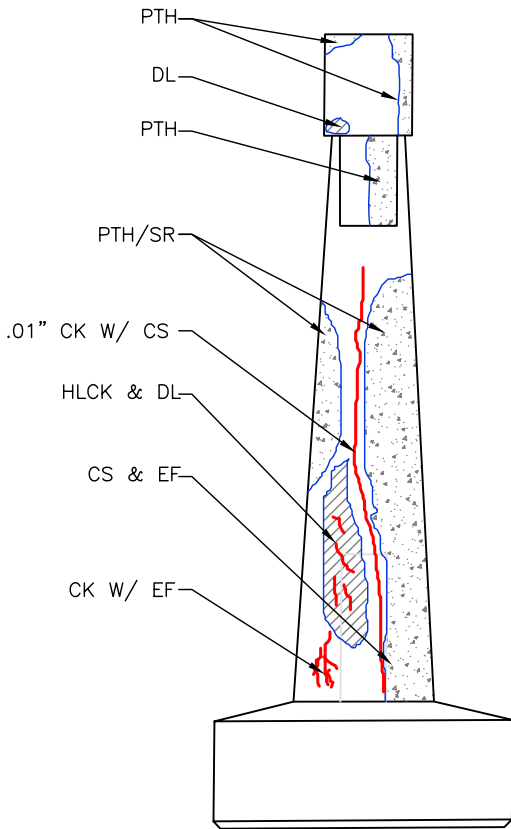

West Ext. Side

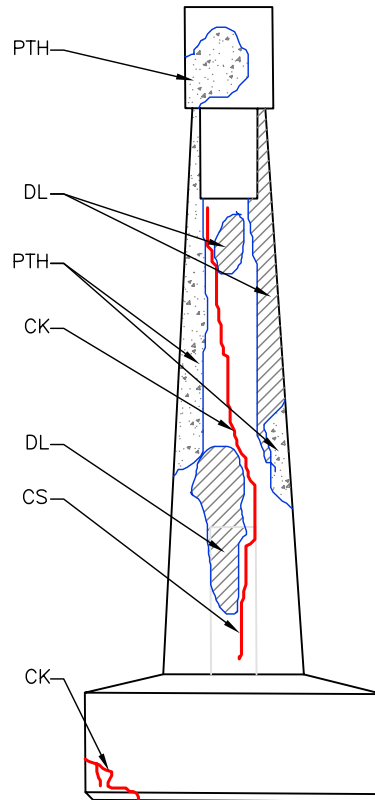

East Ext. Side



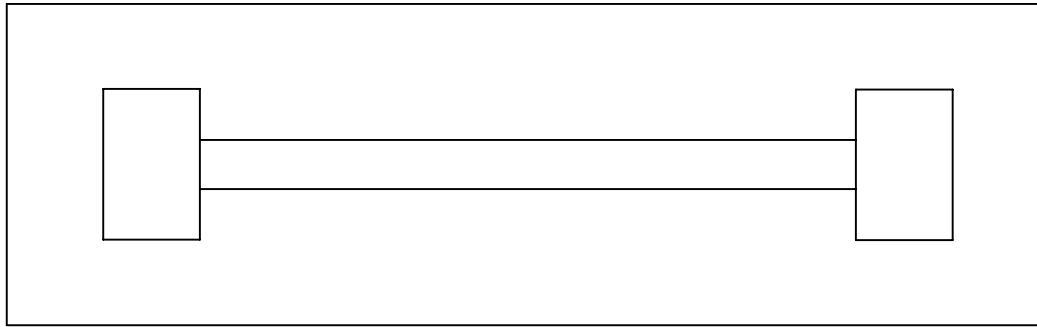

Top of Pile Cap

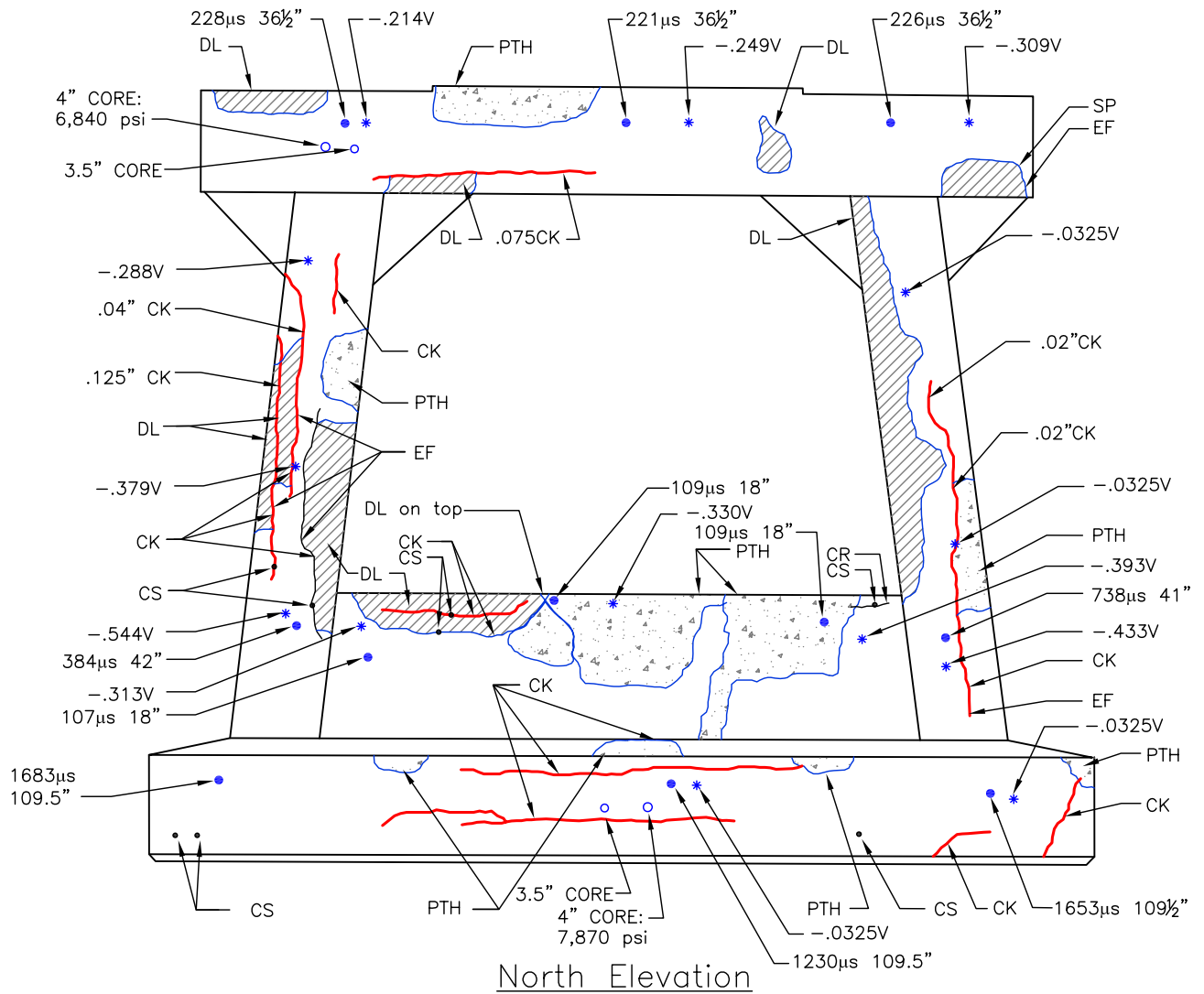



Top of Bent Cap

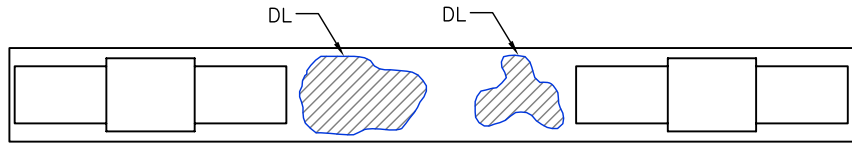

Bottom of Bent Cap

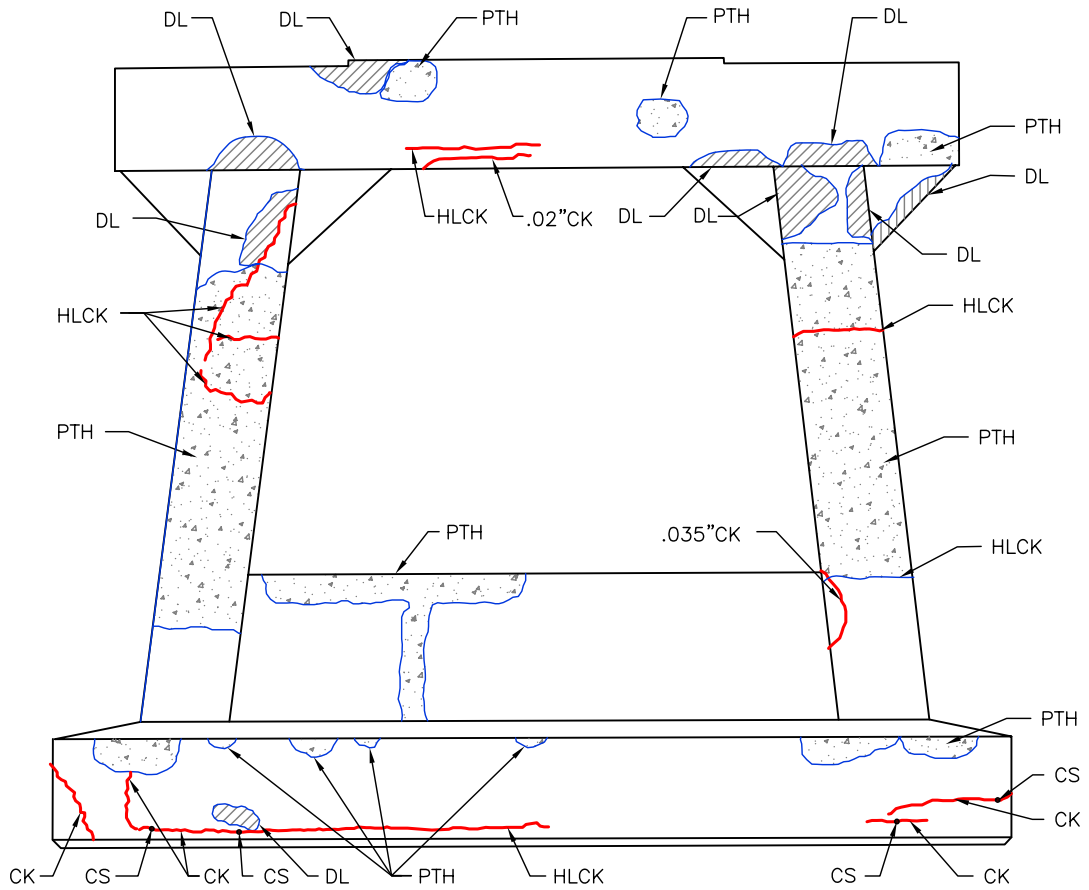

South Elevation

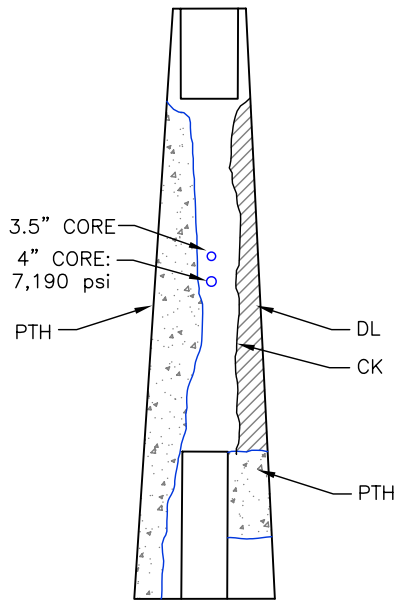

West Int. Side

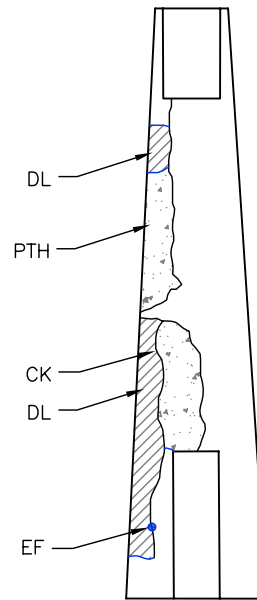

East Int. Side

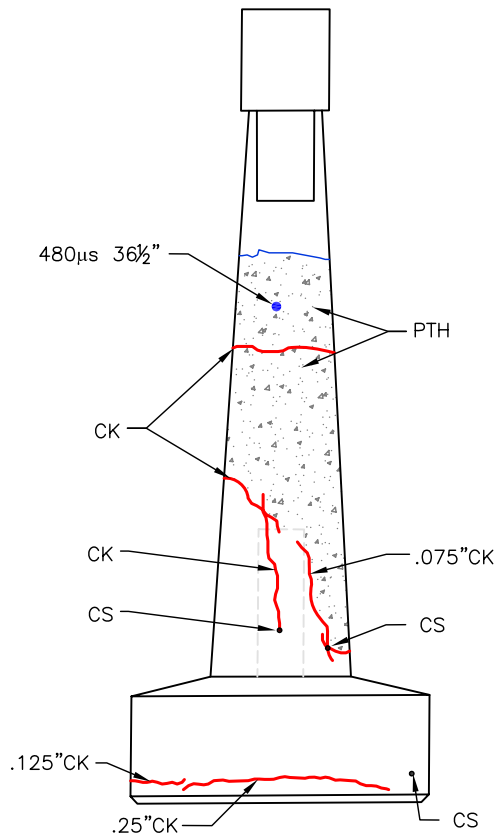

West Ext. Side

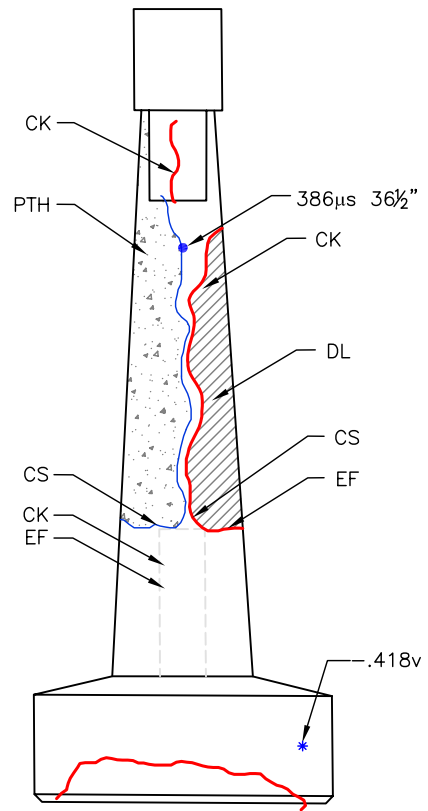

East Ext. Side

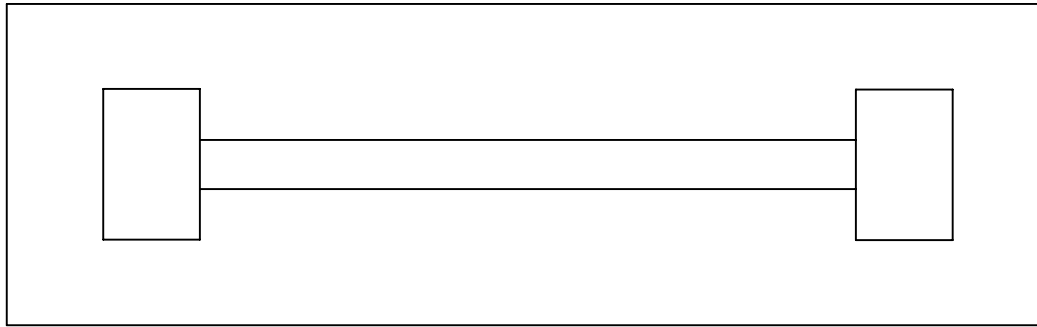

Top of Pile Cap

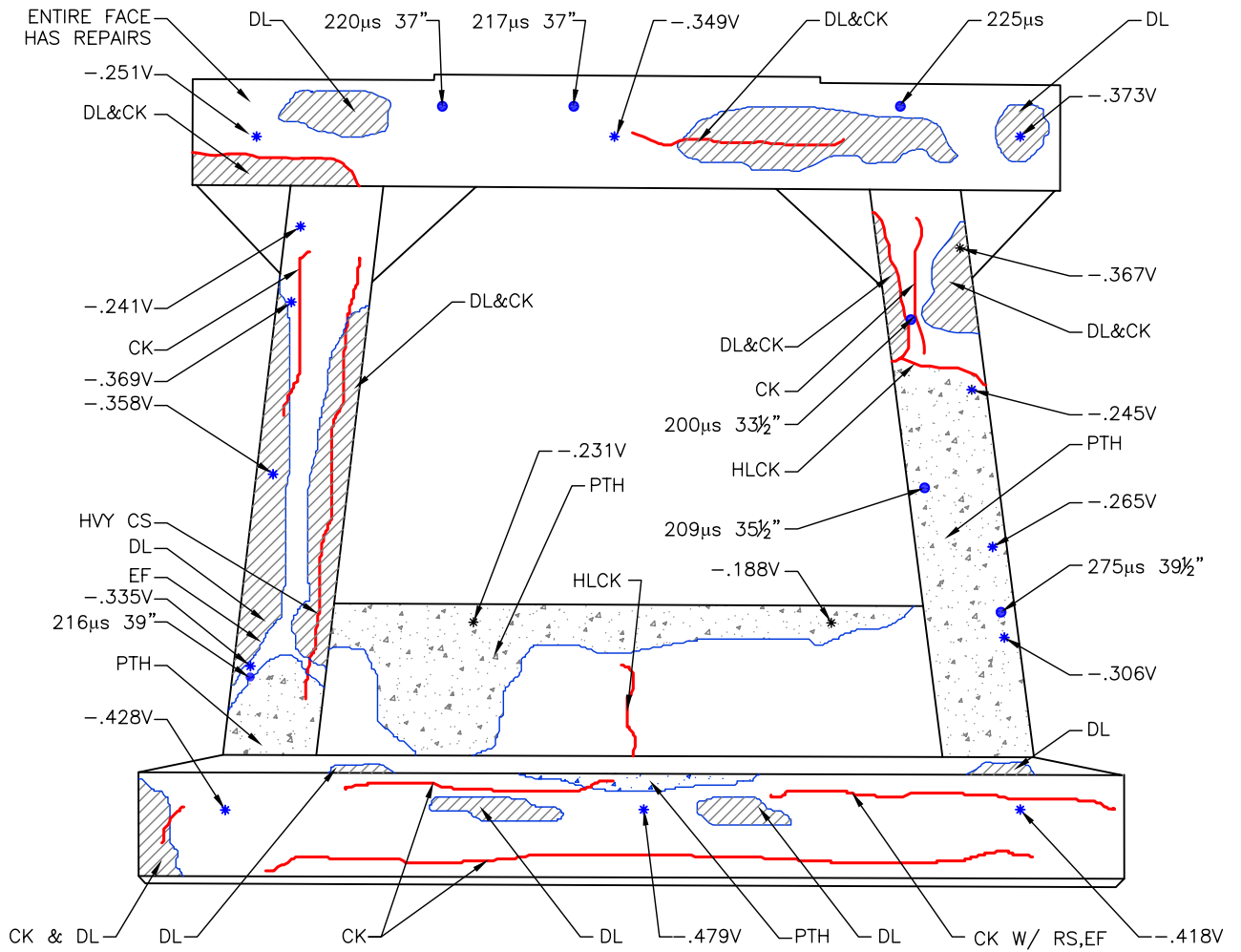

North Elevation

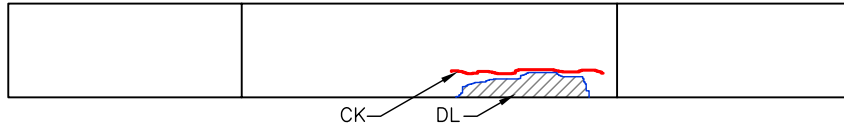

Top of Bent Cap



Bottom of Bent Cap

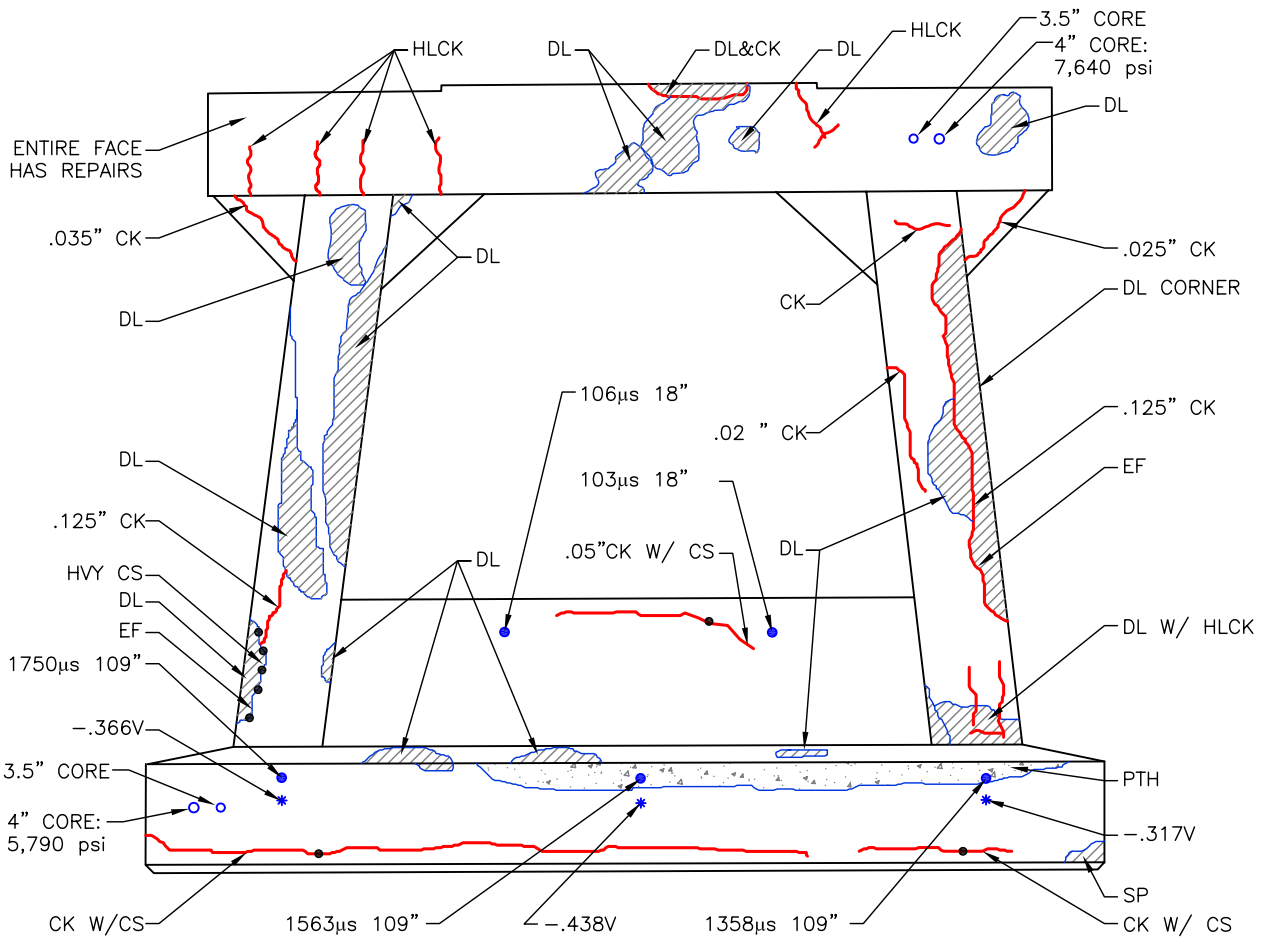

South Elevation

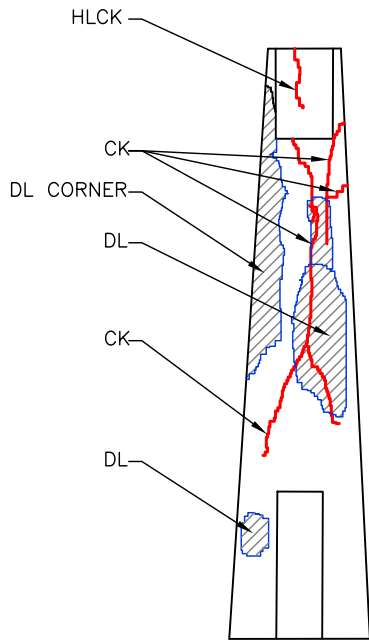

West Int. Side

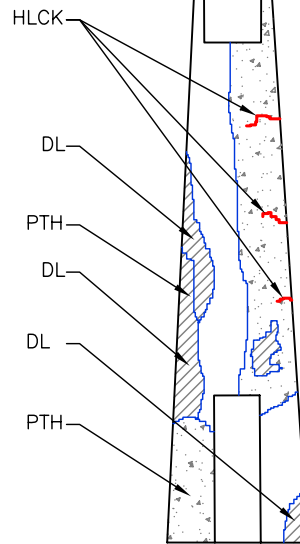

East Int. Side

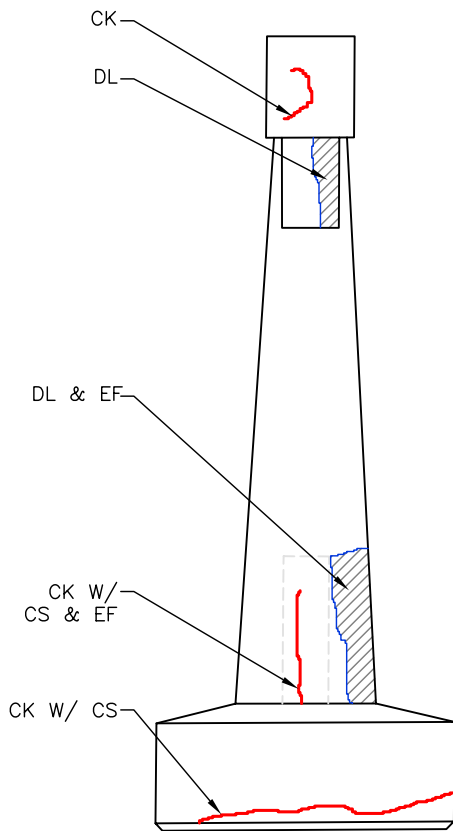

West Ext. Side

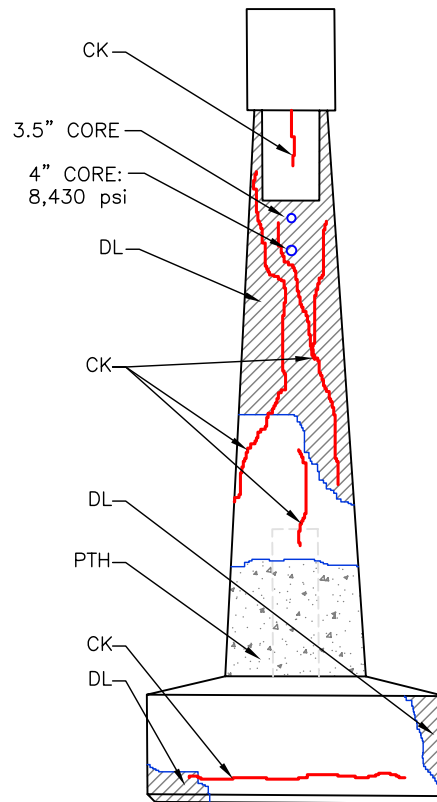

East Ext. Side

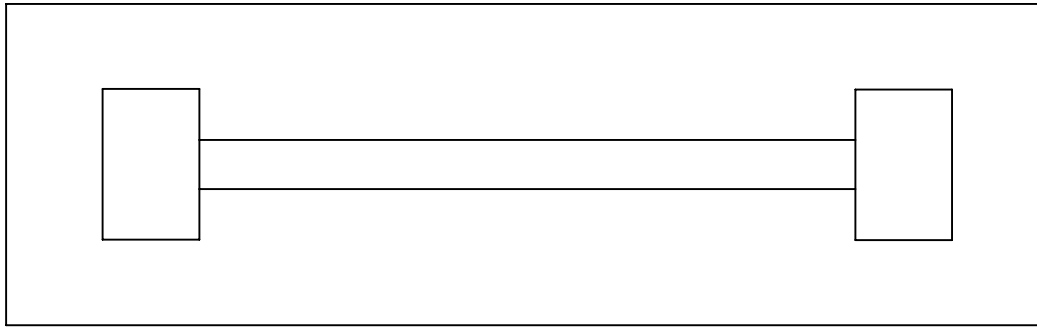

Top of Pile Cap

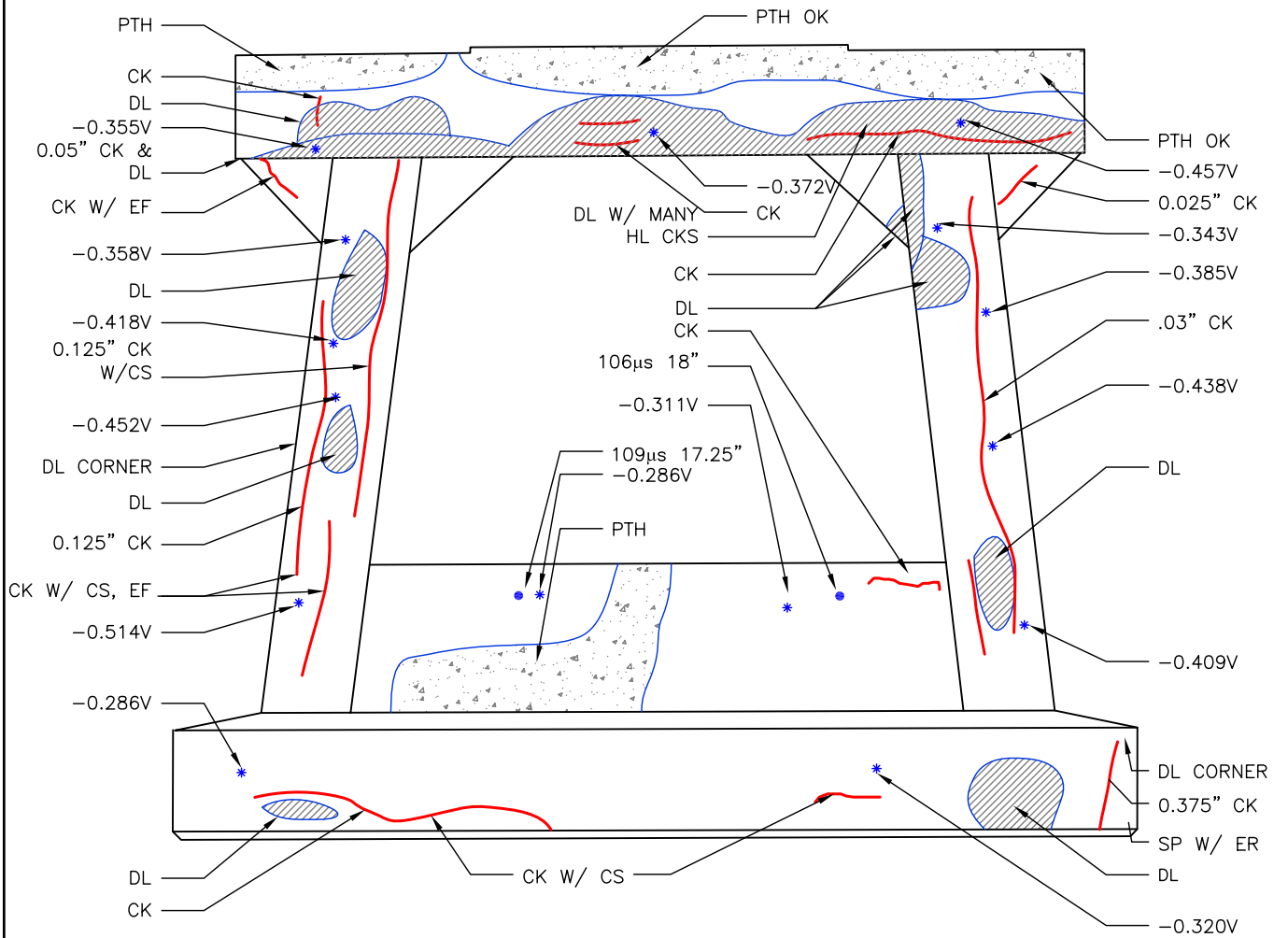

North Elevation

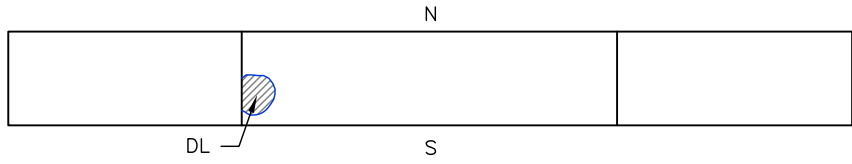

Top of Bent Cap

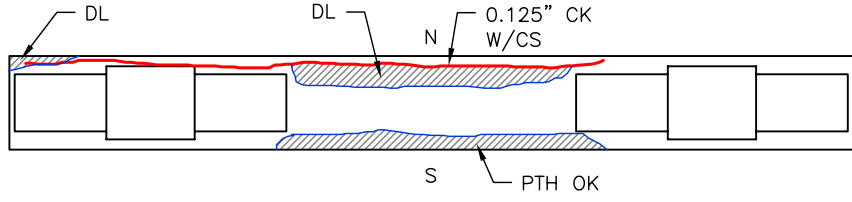

Bottom of Bent Cap

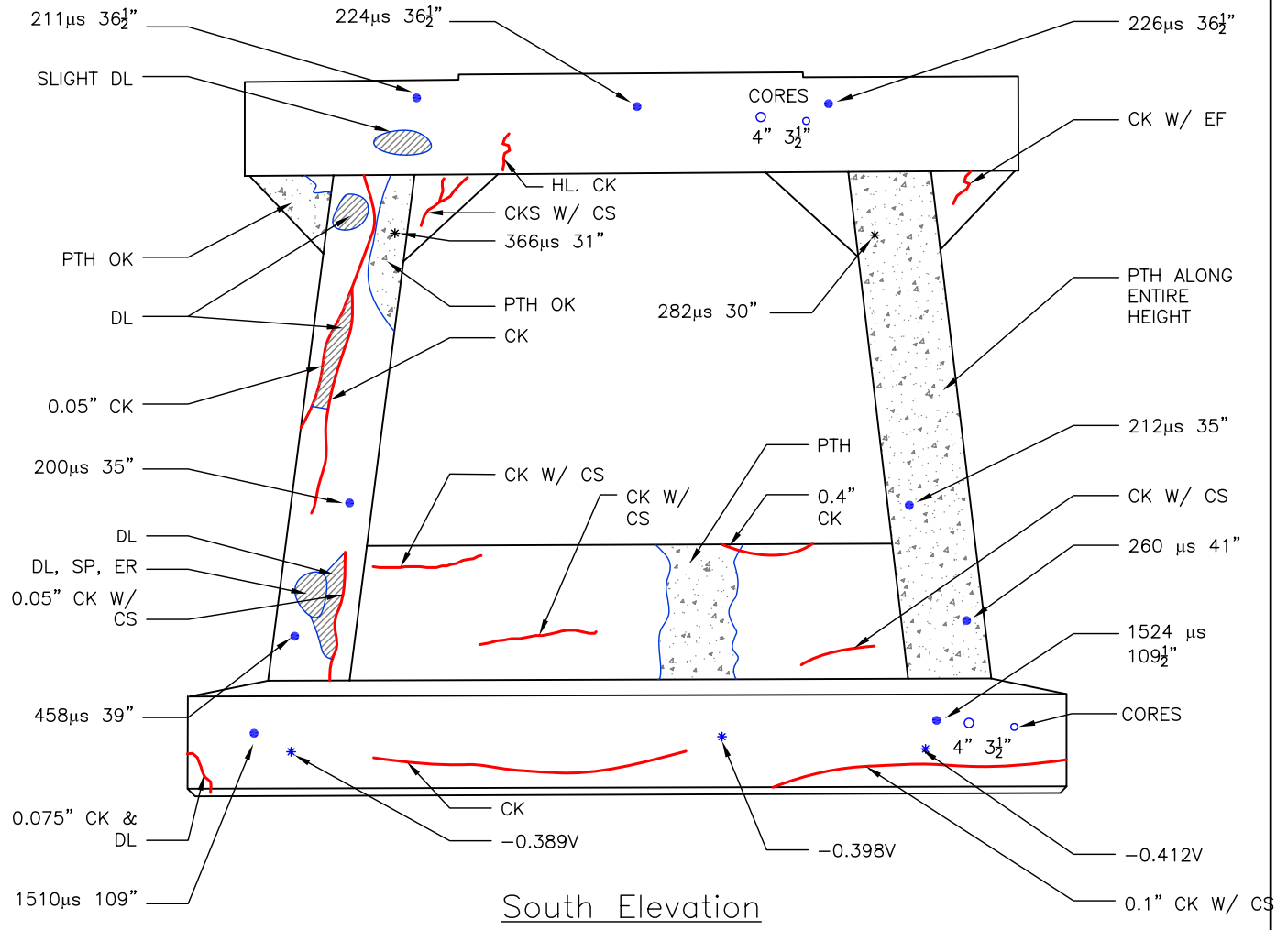

South Elevation



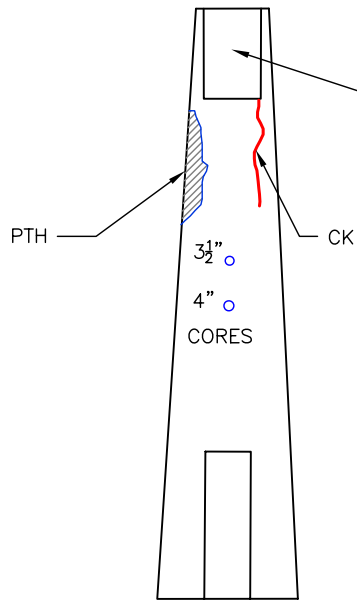

West Int. Side

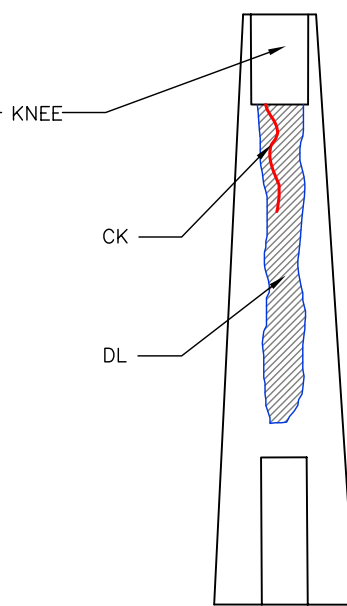

East Int. Side

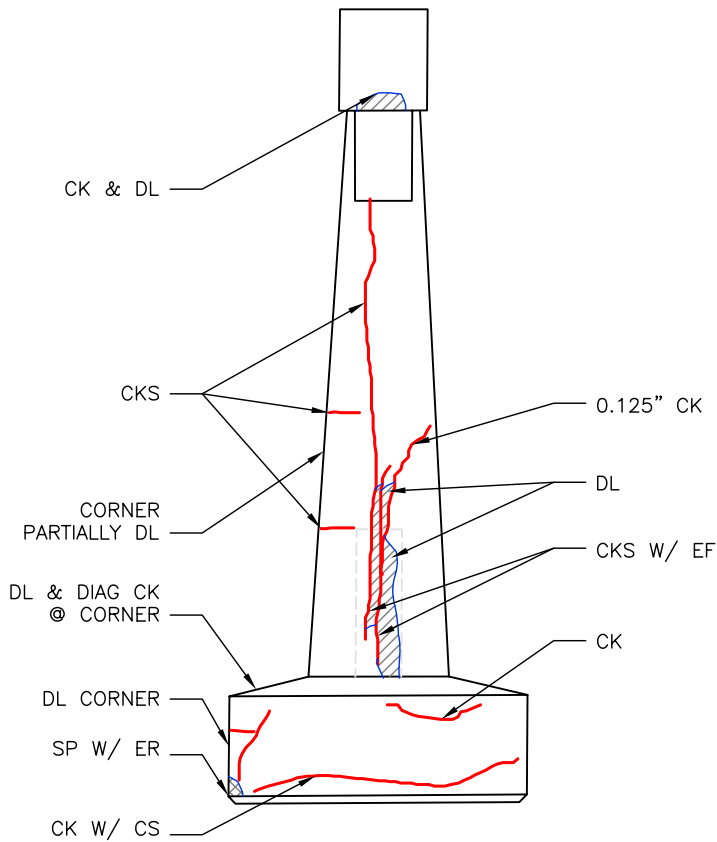

West Ext. Side

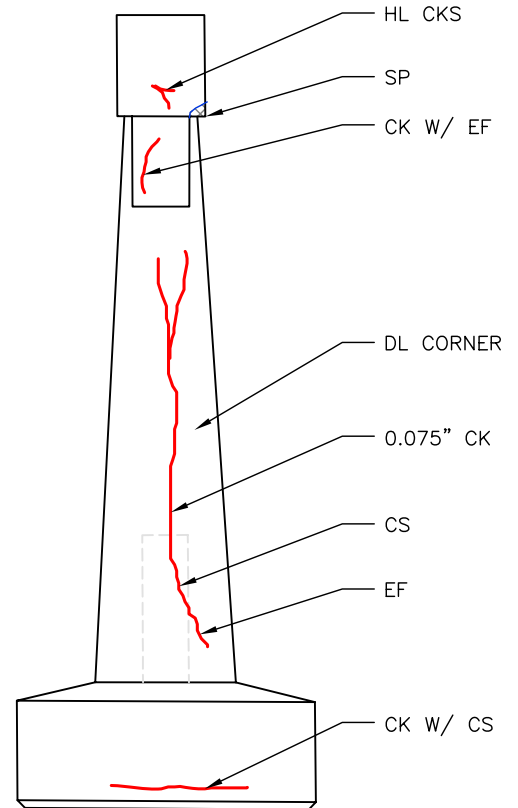

East Ext. Side