

STATE OF NORTH CAROLINA  
DIVISION OF HIGHWAYS

STATE PROJECT REFERENCE NO.	SHEET NO.
R-4071	TCP-1

**PLAN FOR PROPOSED  
TRAFFIC CONTROL, MARKING & DELINEATION  
JOHNSTON COUNTY**

R-4071

TIP PROJECT:

**ROADWAY STANDARD DRAWINGS**

THE FOLLOWING ROADWAY STANDARDS AS APPEAR IN "ROADWAY STANDARD DRAWINGS" - ROADWAY DESIGN UNIT-N.C. DEPARTMENT OF TRANSPORTATION-RALEIGH, N.C., DATED JULY 2006 ARE APPLICABLE TO THIS PROJECT AND BY REFERENCE HEREBY ARE CONSIDERED A PART OF THESE PLANS:

STD. NO.	TITLE
1101.02	TEMPORARY LANE CLOSURES
1101.04	TEMPORARY SHOULDER CLOSURES
1101.05	WORK ZONE VEHICLE ACCESSES
1101.11	TRAFFIC CONTROL DESIGN TABLES
1110.01	STATIONARY WORK ZONE SIGNS
1110.02	PORTABLE WORK ZONE SIGNS
1115.01	FLASHING ARROW PANELS
1130.01	DRUMS
1135.01	CONES
1145.01	TYPE III BARRICADES
1150.01	FLAGGERS
1205.01	PAVEMENT MARKINGS - LINE TYPES & OFFSETS
1205.02	PAVEMENT MARKINGS - 2 LANE & MULTILANE ROADWAYS
1205.04	PAVEMENT MARKINGS - INTERSECTIONS
1205.05	PAVEMENT MARKINGS - TURN LANES
1205.08	PAVEMENT MARKINGS - SYMBOLS & WORD MESSAGES
1250.01	PAVEMENT MARKER SPACING
1251.01	RAISED PAVEMENT MARKERS (TEMPORARY & PERMANENT)

**INDEX OF SHEETS**

SHEET NO.	TITLE
TCP-1	LIST OF APPLICABLE ROADWAY STANDARD DRAWINGS, LEGEND, AND INDEX OF SHEETS
TCP-2 & 2A	GENERAL NOTES, TEMPORARY PAVEMENT MARKING SCHEDULE
TCP-3	PHASE I DETAILS AND PHASING
TCP-4 & TCP-5	PHASE II DETAILS AND PHASING & PHASE III PHASING
TCP-6	DETOUR FOR BAKER STREET AND KEEN STREET
TCP-7	DETOUR FOR MAIN STREET
TCP-8	WORK ZONE WARNING SIGN DETAIL
TCP-9	DETOUR SIGN DESIGNS
PM-1	FINAL PAVEMENT MARKING PLANS AND FINAL PAVEMENT SCHEDULE

**LEGEND**

- GENERAL**
- DIRECTION OF TRAFFIC FLOW
  - NORTH ARROW
  - PROPOSED PVMT. EXIST. PVMT.
  - WORK AREA
  - REMOVAL OF EXISTING PAVEMENT
- TRAFFIC CONTROL DEVICES**
- TYPE III BARRICADE
  - CONE
  - DRUM
  - FLASHING ARROW PANEL (TYPE C)
  - TYPE 'B' WARNING LIGHT
  - STATIONARY SIGN
  - PORTABLE SIGN
  - STATIONARY OR PORTABLE SIGN
  - CHANGEABLE MESSAGE SIGN
  - TRUCK MOUNTED IMPACT ATTENUATOR (TMIA)
  - POLICE
  - FLAGGER
- PAVEMENT MARKINGS**
- PAVEMENT MARKING SYMBOLS

07-MAY-2007 14:51 \\dot\dfsroot\on\p\proj\TIP\Projects-R\4071\Traffic\TrafficControl\Top\4071.fc\_top01.tsh.dgn idonaldson AT WZTC21223

APPROVED: DATE: 5/3/07	PLAN PREPARED BY: N.C.D.O.T. TRAFFIC CONTROL, MARKING & DELINEATION SECTION
SEAL 	I. S. BOURNE, PE TRAFFIC CONTROL ENGINEER G. L. GETTIER, PE TRAFFIC CONTROL PROJECT ENGINEER I. W. WOOLARD, PE TRAFFIC CONTROL PROJECT DESIGN ENGINEER L. K. DONALDSON TRAFFIC CONTROL DESIGN ENGINEER / TECHNICIAN

# PROJECT NOTES

## GENERAL NOTES

ADAPT THE TRAFFIC CONTROL PLANS, WHEN DIRECTED BY THE ENGINEER, TO MEET FIELD CONDITIONS TO PROVIDE SAFE AND EFFICIENT TRAFFIC MOVEMENT. CHANGES MAY BE REQUIRED WHEN PHYSICAL DIMENSIONS IN THE DETAIL DRAWINGS, STANDARD DETAILS AND ROADWAY DETAILS ARE NOT ATTAINABLE, OR RESULT IN DUPLICATE, OR UNDESIRE OVERLAPPING OF DEVICES. MODIFICATION MAY INCLUDE: MOVING, SUPPLEMENTING, COVERING OR REMOVAL OF DEVICES.

THE FOLLOWING GENERAL NOTES APPLY AT ALL TIMES FOR THE DURATION OF THE CONSTRUCTION PROJECT, EXCEPT WHEN OTHERWISE NOTED IN THE PLAN, OR DIRECTED BY THE ENGINEER.

## TIME RESTRICTIONS

A) DO NOT CLOSE OR NARROW TRAVEL LANES DURING HOLIDAYS AND SPECIAL EVENTS AS FOLLOWS:

### ROAD NAME

US 301, KEEN RD, BOYETTE RD

### HOLIDAY

- FOR ANY UNEXPECTED OCCURRENCE THAT CREATES UNUSUALLY HIGH TRAFFIC VOLUMES, AS DIRECTED BY THE ENGINEER.
- FOR NEW YEAR'S, BETWEEN THE HOURS OF 3:30 P.M. DECEMBER 31st TO 7:00 A.M. JANUARY 2ND. IF NEW YEAR'S DAY IS ON A FRIDAY, SATURDAY, SUNDAY, OR MONDAY THEN UNTIL 7:00 A.M. THE FOLLOWING TUESDAY.
- FOR EASTER, BETWEEN THE HOURS OF 3:30 P.M. THURSDAY AND 7:00 A.M. MONDAY.
- FOR MEMORIAL DAY, BETWEEN THE HOURS OF 3:30 P.M. FRIDAY TO 7:00 A.M. TUESDAY.
- FOR INDEPENDENCE DAY, BETWEEN THE HOURS OF 3:30 P.M. THE DAY BEFORE INDEPENDENCE DAY AND 7:00 A.M. THE DAY AFTER INDEPENDENCE DAY.

IF INDEPENDENCE DAY IS ON A FRIDAY, SATURDAY, SUNDAY OR MONDAY THEN BETWEEN THE HOURS OF 3:30 P.M. THE THURSDAY BEFORE INDEPENDENCE DAY AND 7:00 A.M. THE TUESDAY AFTER INDEPENDENCE DAY.

- FOR LABOR DAY, BETWEEN THE HOURS OF 3:30 P.M. FRIDAY AND 7:00 A.M. TUESDAY.
- FOR THANKSGIVING DAY, BETWEEN THE HOURS OF 3:30 P.M. TUESDAY TO 7:00 A.M. MONDAY.
- FOR CHRISTMAS, BETWEEN THE HOURS OF 3:30 P.M. THE FRIDAY BEFORE THE WEEK OF CHRISTMAS DAY AND 7:00 A.M. THE FOLLOWING TUESDAY AFTER THE WEEK OF CHRISTMAS.

## TIME RESTRICTIONS

A) DO NOT CLOSE OR NARROW TRAVEL LANES AS FOLLOWS:

### ROAD NAME

### DAY AND TIME RESTRICTIONS

- US 301, KEEN RD., BOYETTE RD. FROM 7:00 A.M. TO 8:00 A.M. MONDAY THROUGH FRIDAY.  
FROM 2:30 P.M. TO 3:30 P.M. MONDAY THROUGH FRIDAY.

B) DO NOT STOP TRAFFIC OR CLOSE ROADS AS FOLLOWS:

### ROAD NAME

### DAY AND TIME RESTRICTIONS

- US 301, KEEN RD., BOYETTE RD. 6:00 A.M. TO 12:00 MIDNIGHT MONDAY THROUGH SUNDAY

## LANE AND SHOULDER CLOSURE REQUIREMENTS

- C) REMOVE LANE CLOSURE DEVICES FROM THE LANE WHEN WORK IS NOT BEING PERFORMED BEHIND THE LANE CLOSURE OR WHEN A LANE CLOSURE IS NO LONGER NEEDED, OR AS DIRECTED BY THE ENGINEER.
- D) WHEN PERSONNEL AND/OR EQUIPMENT ARE WORKING WITHIN 40 FT OF AN OPEN TRAVEL LANE, CLOSE THE NEAREST OPEN SHOULDER USING ROADWAY STANDARD DRAWING NO. 1101.04 UNLESS THE WORK AREA IS PROTECTED BY BARRIER OR GUARDRAIL.
- E) WHEN PERSONNEL AND/OR EQUIPMENT ARE WORKING ON THE SHOULDER ADJACENT TO AN UNDIVIDED FACILITY AND WITHIN 5 FT OF AN OPEN TRAVEL LANE, CLOSE THE NEAREST OPEN TRAVEL LANE USING ROADWAY STANDARD DRAWING NO. 1101.02 UNLESS THE WORK AREA IS PROTECTED BY BARRIER OR GUARDRAIL.
- WHEN PERSONNEL AND/OR EQUIPMENT ARE WORKING ON THE SHOULDER ADJACENT TO A DIVIDED FACILITY AND WITHIN 10 FT OF AN OPEN TRAVEL LANE, CLOSE THE NEAREST OPEN TRAVEL LANE USING ROADWAY STANDARD DRAWING NO. 1101.02 UNLESS THE WORK AREA IS PROTECTED BY BARRIER OR GUARDRAIL.
- F) WHEN PERSONNEL AND/OR EQUIPMENT ARE WORKING WITHIN A LANE OF TRAVEL OF AN UNDIVIDED OR DIVIDED FACILITY, CLOSE THE LANE ACCORDING TO THE TRAFFIC CONTROL PLANS, ROADWAY STANDARD DRAWINGS OR AS DIRECTED BY THE ENGINEER. CONDUCT THE WORK SO THAT ALL PERSONNEL AND/OR EQUIPMENT REMAIN WITHIN THE CLOSED TRAVEL LANE.
- G) DO NOT WORK SIMULTANEOUSLY, ON BOTH SIDES OF AN OPEN TRAVELWAY, WITHIN THE SAME LOCATION, ON A TWO-LANE, TWO-WAY ROAD.
- H) DO NOT PERFORM WORK INVOLVING HEAVY EQUIPMENT WITHIN 15 FT OF THE EDGE OF TRAVELWAY WHEN WORK IS BEING PERFORMED BEHIND A LANE CLOSURE ON THE OPPOSITE SIDE OF THE TRAVELWAY.
- I) DO NOT INSTALL MORE THAN ONE LANE CLOSURE, IN ANY ONE DIRECTION, ON US 301, KEEN RD. AND BOYETTE RD.
- J) PROVIDE TRAFFIC CONTROL FOR APPROPRIATE LANE CLOSURES FOR SURVEYING DONE BY THE DEPARTMENT.

## PAVEMENT EDGE DROP OFF REQUIREMENTS

- K) BACKFILL AT A 6:1 SLOPE UP TO THE EDGE AND ELEVATION OF EXISTING PAVEMENT IN AREAS ADJACENT TO AN OPENED TRAVEL LANE THAT HAS A DROP-OFF AS FOLLOWS:
- BACKFILL DROP-OFFS THAT EXCEED 2 INCHES ON ROADWAYS WITH POSTED SPEED LIMITS OF 45 MPH OR GREATER.
- BACKFILL DROP-OFFS THAT EXCEED 3 INCHES ON ROADWAYS WITH POSTED SPEED LIMITS LESS THAN 45 MPH.
- BACKFILL WITH SUITABLE COMPACTED MATERIAL, AS APPROVED BY THE ENGINEER, AT NO EXPENSE TO THE DEPARTMENT.
- L) DO NOT EXCEED A DIFFERENCE OF 1.5 inches IN ELEVATION BETWEEN OPEN LANES OF TRAFFIC. INSTALL ADVANCE WARNING "UNEVEN LANES" SIGNS (W8-11) 500 FT IN ADVANCE AND A MINIMUM OF ONCE EVERY MILE THROUGHOUT THE UNEVEN AREA.

## TRAFFIC PATTERN ALTERATIONS

M) NOTIFY THE ENGINEER TWENTY ONE (21) CALENDAR DAYS PRIOR TO ANY TRAFFIC PATTERN ALTERATION.

## SIGNING

- N) INSTALL ADVANCE WORK ZONE WARNING SIGNS WHEN WORK IS WITHIN 100 FT FROM THE EDGE OF TRAVEL LANE AND NO MORE THAN THREE (3) DAYS PRIOR TO THE BEGINNING OF CONSTRUCTION.
- WHEN NO WORK IS BEING CONDUCTED FOR A PERIOD LONGER THAN ONE WEEK, REMOVE OR COVER ALL ADVANCE WORK ZONE WARNING SIGNS, AS DIRECTED BY THE ENGINEER, AT NO COST TO THE DEPARTMENT.
- O) PROVIDE PERMANENT SIGNING.
- P) PROVIDE DETOUR SIGNING WITHIN AND OFF THE PROJECT LIMITS.
- Q) COVER OR REMOVE ALL DETOUR SIGNS WITHIN AND OFF THE PROJECT LIMITS WHEN A DETOUR IS NOT IN OPERATION.
- R) ENSURE ALL NECESSARY SIGNING IS IN PLACE PRIOR TO ALTERING ANY TRAFFIC PATTERN.
- S) INSTALL BLACK ON ORANGE "DIP" SIGNS (W8-2) 500 FT IN ADVANCE OF THE UNEVEN AREA.
- T) INSTALL BLACK ON ORANGE "BUMP" SIGNS (W8-1) 500 FT IN ADVANCE OF THE UNEVEN AREA.

## TRAFFIC BARRIER

U) INSTALL MOVABLE/PORTABLE CONCRETE BARRIER ACCORDING TO THE TRAFFIC CONTROL PLANS A MAXIMUM OF TWO (2) WEEKS PRIOR TO BEGINNING WORK IN ANY LOCATION. ONCE MOVABLE/PORTABLE CONCRETE BARRIER IS INSTALLED AT ANY LOCATION, PROCEED IN A CONTINUOUS MANNER TO COMPLETE THE PROPOSED WORK IN THAT LOCATION UNLESS OTHERWISE STATED IN THE TRAFFIC CONTROL PLANS OR AS DIRECTED BY THE ENGINEER.

ONCE MOVABLE/PORTABLE CONCRETE BARRIER IS INSTALLED AT ANY LOCATION AND NO WORK IS PERFORMED BEHIND THE MOVABLE/PORTABLE CONCRETE BARRIER FOR A PERIOD LONGER THAN TWO (2) MONTHS, REMOVE/RESET MOVABLE/PORTABLE CONCRETE BARRIER AT NO COST TO THE DEPARTMENT UNLESS OTHERWISE STATED IN THE TRAFFIC CONTROL PLANS, BARRIER IS PROTECTING A HAZARD, OR AS DIRECTED BY THE ENGINEER.

V) PROTECT THE APPROACH END OF MOVABLE/PORTABLE CONCRETE BARRIER AT ALL TIMES DURING THE INSTALLATION AND REMOVAL OF THE BARRIER BY EITHER A TRUCK MOUNTED IMPACT ATTENUATOR (MAXIMUM 72 HOURS) OR A TEMPORARY CRASH CUSHION.

OFFSET THE APPROACH END OF MOVABLE/PORTABLE CONCRETE BARRIER A MINIMUM OF 40 FT FROM ONCOMING TRAFFIC OR PROTECT AT ALL TIMES BY A TEMPORARY CRASH CUSHION.

INSTALL MOVABLE/PORTABLE CONCRETE BARRIER WITH THE TRAFFIC FLOW, BEGINNING WITH THE UPSTREAM SIDE OF TRAFFIC. REMOVE MOVABLE/PORTABLE CONCRETE BARRIER AGAINST THE TRAFFIC FLOW, BEGINNING WITH THE DOWNSTREAM SIDE OF TRAFFIC.

INSTALL AND SPACE DRUMS NO GREATER THAN TWICE THE POSTED SPEED LIMIT (35 MPH) TO CLOSE OR KEEP CLOSED THE SECTION OF THE ROADWAY UNTIL THE BARRIER CAN BE PLACED OR AFTER BARRIER IS REMOVED.

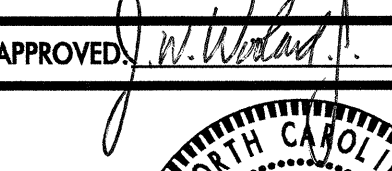
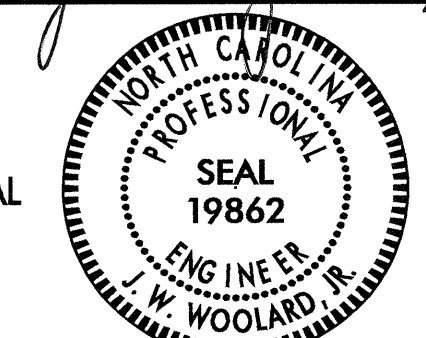
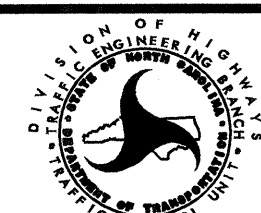
APPROVED: 	DATE: 5/4/07	<h1>PROJECT NOTES</h1>			
SEAL 	SCALE: NONE				
	DATE:	REVISIONS			
	DWG. BY: LKD				
	DESIGN BY: LKD				
REVIEWED BY: JWW	CADD FILE				



TRAFFIC CONTROL DEVICES

- W) WHEN USING ROADWAY STANDARD NO. 1101.02, (CONES OR DRUMS) MAY BE USED IN LIEU OF (DRUMS OR CONES) ON (ROAD NAME).
- X) SPACE CHANNELIZING DEVICES IN WORK AREAS NO GREATER THAN TWICE THE POSTED SPEED LIMIT (35 MPH), EXCEPT 10 FT ON-CENTER IN RADII, AND 3 FT OFF THE EDGE OF AN OPEN TRAVELWAY, WHEN LANE CLOSURES ARE NOT IN EFFECT.
- Y) PLACE TYPE III BARRICADES, WITH "ROAD CLOSED" SIGN R11-2 ATTACHED, OF SUFFICIENT LENGTH TO CLOSE ENTIRE ROADWAY. STAGGER OR OVERLAP BARRICADES TO ALLOW FOR INGRESS OR EGRESS.
- Z) PLACE SETS OF THREE DRUMS PERPENDICULAR TO THE EDGE OF THE TRAVELWAY ON 500 FT CENTERS WHEN UNOPENED LANES ARE CLOSED TO TRAFFIC. THESE DRUMS SHALL BE IN ADDITION TO CHANNELIZING DEVICES.

PAVEMENT MARKINGS AND MARKERS

AA) INSTALL PAVEMENT MARKINGS AND PAVEMENT MARKERS ON THE FINAL SURFACE AS FOLLOWS:

ROAD NAME	MARKING	MARKERS
1. US 301 (-Y-)	THERMOPLASTIC	PERMANENT RAISED
2. KEEN RD. (-L-)	THERMOPLASTIC	PERMANENT RAISED
3. BOYETTE RD. (-Y3-)	PAINT	PERMANENT RAISED
4. KEEN ST. (-Y2-)	PAINT	PERMANENT RAISED

BB) INSTALL TEMPORARY PAVEMENT MARKINGS AND TEMPORARY PAVEMENT MARKERS ON INTERIM LAYERS OF PAVEMENT AS FOLLOWS:

ROAD NAME	MARKING	MARKERS
1. KEEN RD. (-L-)	PAINT	TEMPORARY RAISED
2. BOYETTE RD. (-Y3-)	PAINT	TEMPORARY RAISED

CC) TIE PROPOSED PAVEMENT MARKING LINES TO EXISTING PAVEMENT MARKING LINES.

DD) REPLACE ANY PAVEMENT MARKINGS THAT HAVE BEEN DAMAGED BY THE END OF EACH DAY'S OPERATION.

EE) PLACE AT LEAST TWO APPLICATIONS OF PAINT ON NEW ASPHALT WITH TEMPORARY TRAFFIC PATTERNS WHICH WILL REMAIN IN PLACE OVER THREE (3) MONTHS. PLACE ADDITIONAL APPLICATIONS OF PAINT UPON SUFFICIENT DRYING TIME, AS DETERMINED BY THE ENGINEER.

TEMPORARY/FINAL SIGNALS

FF) NOTIFY THE ENGINEER TWO (2) MONTHS BEFORE A TRAFFIC SIGNAL INSTALLATION BY OTHERS IS REQUIRED.

GG) SHIFT AND REVISE ALL SIGNAL HEADS AS SHOWN ON THE SIGNAL PLANS.

MISCELLANEOUS

HH) POLICE MAY BE USED TO MAINTAIN TRAFFIC THROUGH INTERSECTIONS.

II) IN THE EVENT A TIE-IN CANNOT BE MADE IN ONE DAYS TIME, BRING THE TIE-IN AREA TO AN APPROPRIATE ROADWAY ELEVATION, AS DETERMINED BY THE ENGINEER. PLACE BLACK ON ORANGE "LOOSE GRAVEL" SIGNS (W8-7) AND BLACK ON ORANGE "PAVEMENT ENDS" SIGNS (W8-3) 500 FT AND 1000 FT RESPECTIVELY IN ADVANCE OF THE UNEVEN AREAS. USE DRUMS TO DELINEATE THE EDGE OF ROADWAY ALONG UNPAVED AREAS.

JJ) PLACE CONES, OR TUBULAR MARKERS TO DELINEATE EXISTING AND PROPOSED ISLANDS AFTER REMOVAL AND BEFORE INSTALLATION.

TEMPORARY PAVEMENT MARKING SCHEDULE

SYMBOL	DESCRIPTION
<u>PAVEMENT MARKINGS</u>	
<u>PAINT (24")</u>	
P4	WHITE STOPBAR (1X)
<u>PAINT (4")</u>	
PA	WHITE EDGELINE (1X)
PD	2 FT. WHITE MINISKIP (1X)
PI	YELLOW DOUBLE CENTER (1X)
<u>TEMPORARY RAISED PAVEMENT MARKERS</u>	
MH	YELLOW & YELLOW
MI	CRYSTAL & RED

NOTE: FOR EACH PAINT PAVEMENT MARKING ITEM, 1X IMPLIES A SINGLE APPLICATION, 2X IMPLIES TWO APPLICATIONS.

APPROVED: <i>J.W. Woolard</i> DATE: 5/3/07	<b>PROJECT NOTES</b>	
	SCALE: NONE	
	DATE:	
	DWG. BY: LKD	
	DESIGN BY: LKD	
REVIEWED BY: JWW	REVISIONS	

NOTE: RETURN TRAFFIC TO THE EXISTING PATTERN AT THE END OF EACH WORKDAY UNLESS OTHERWISE NOTED IN THE TRAFFIC CONTROL PHASING.

NOTE: COMPLETE THE WORK REQUIRED IN PHASE I, STEP 3 IN 60 CONSECUTIVE CALENDAR DAYS. (SEE SPECIAL PROVISIONS)

NOTE: COMPLETE THE WORK REQUIRED IN PHASE I, STEP 5 IN 14 CONSECUTIVE CALENDAR DAYS. (SEE SPECIAL PROVISIONS)

**PHASE I**

STEP 1: USING TCP-8 INSTALL ALL WORK ZONE ADVANCE WARNING SIGNS PRIOR TO ANY CONSTRUCTION ACTIVITY.

STEP 3: USING ROADWAY STANDARD DRAWING NO. 1101.03, SHEET 1 OR 2 OF 9, INSTALL OFF-SITE DETOUR SIGNING AS SHOWN ON SHEET TCP-7, PLACE TRAFFIC ON THE OFF-SITE DETOUR, AND CLOSE -Y8- (MAIN ST.) TO TRAFFIC.

STEP 5: USING ROADWAY STANDARD DRAWING NO. 1101.03, SHEET 1 OR 2 OF 9, INSTALL OFF-SITE DETOUR SIGNING AS SHOWN ON SHEET TCP-6, PLACE TRAFFIC ON THE OFF-SITE DETOUR, AND CLOSE -Y7- (BAKER ST.) TO TRAFFIC.

NOTE: PHASE I, STEPS 2, 3 AND 4 OR PHASE I, STEPS 2, 3, AND 5 MAY BE PERFORMED CONCURRENTLY. DO NOT PERFORM PHASE I, STEPS 4 AND 5 CONCURRENTLY. THE ASSOCIATED INTERMEDIATE CONTRACT TIME FOR PHASE I, STEP 3, 4 OR 5 WILL BEGIN ONCE WORK ON THAT STEP STARTS.

CONSTRUCT ARCH PIPE AT -Y8- STA 12+33+/- AS SHOWN IN THE CONSTRUCTION PLANS. (SEE TCP-5)

INSTALL PIPE ON -Y7- FROM STA 11+88+/- TO 12+17+/- AS SHOWN IN THE CONSTRUCTION PLANS. (SEE TCP-5)

NOTE: COMPLETE THE WORK REQUIRED IN PHASE I, STEP 4 IN 30 CONSECUTIVE CALENDAR DAYS. (SEE SPECIAL PROVISIONS)

STEP 6: USING FLAGGERS AND ROADWAY STANDARD DRAWING 1101.02, SHEET 1 OF 9, CONSTRUCT ROADWAY UP TO BUT NOT INCLUDING THE FINAL LAYER OF THE SURFACE COURSE ON:

STEP 2: USING FLAGGERS AND ROADWAY STANDARD DRAWING 1101.02, SHEET 1 OF 9, CONSTRUCT ROADWAY UP TO BUT NOT INCLUDING THE FINAL LAYER OF THE SURFACE COURSE ON:

- L- LEFT STA 10+12+/- TO STA 19+41+/- (INCLUDING DRIVEWAY ISLAND FOR PARCEL #8)
- L- LEFT STA 19+69+/- TO STA 26+58+/-
- Y- LEFT STA 14+00+/- TO STA 14+81+/-
- Y3- STA 10+00+/- TO STA 12+78+/-

STEP 4: USING ROADWAY STANDARD DRAWING NO. 1101.03, SHEET 1 OR 2 OF 9, INSTALL OFF-SITE DETOUR SIGNING AS SHOWN ON SHEET TCP-6, PLACE TRAFFIC ON THE OFF-SITE DETOUR, AND CLOSE -Y2- (KEEN ST.) TO TRAFFIC.

-Y3- RIGHT STA 10+00+/- TO STA 12+84+/-

INSTALL PIPES ON -Y2- FROM -Y2- STA 10+24+/- TO STA 19+89+/- AS SHOWN IN THE CONSTRUCTION PLANS. (SEE TCP-5)

STEP 7: USING FLAGGERS AND ROADWAY STANDARD DRAWING 1101.02, SHEET 1 OF 9, INSTALL TEMPORARY PAVEMENT MARKINGS (PAINT) AND RAISED MARKERS (TEMPORARY) AND SHIFT TRAFFIC INTO THE PATTERN AS SHOWN ON SHEET TCP-4 ON:

- L- FROM STA. 10+12 +/- TO STA. 26+58 +/-
- Y3- FROM STA. 10+00 +/- TO STA. 12+78 +/-

REVISE SIGNAL AT -L- AND -Y- TO MATCH THE NEW TRAFFIC PATTERN AS SHOWN ON TCP-4.

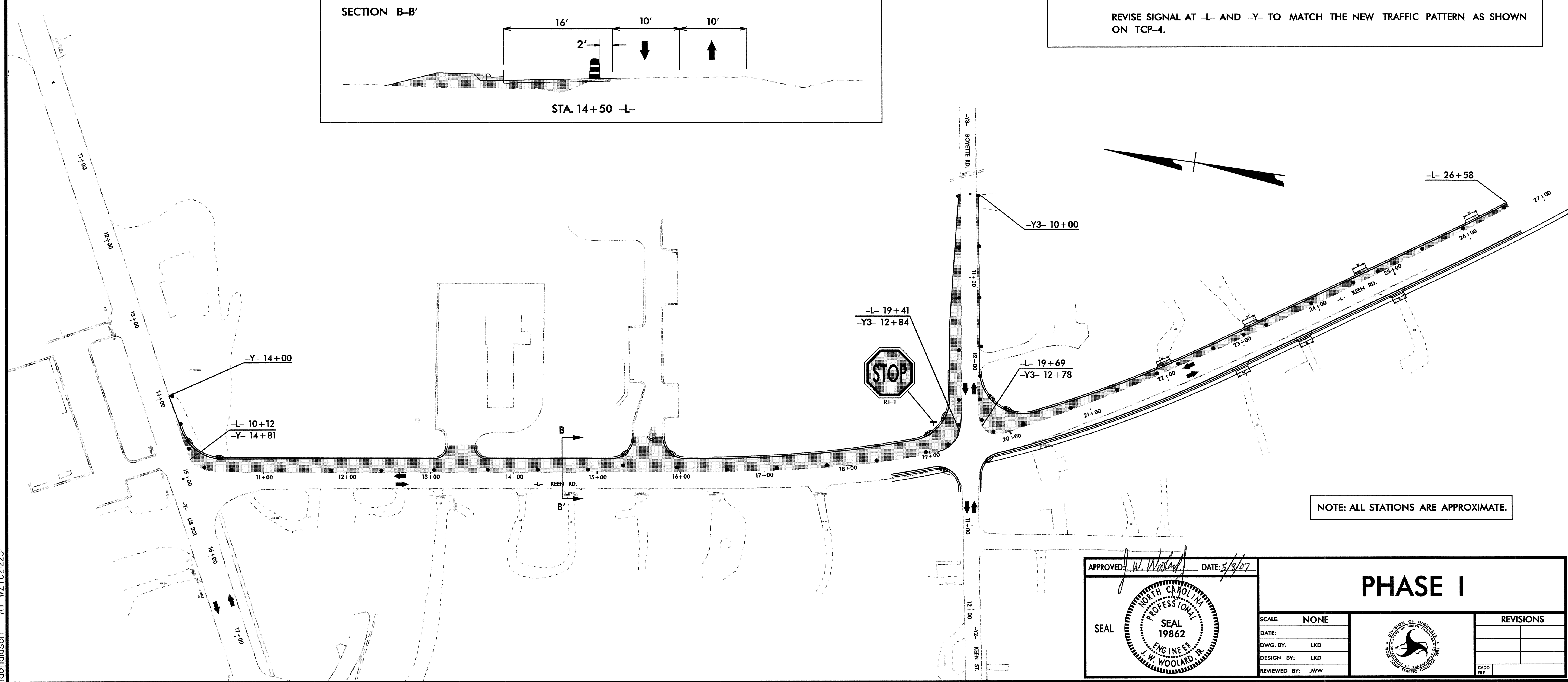
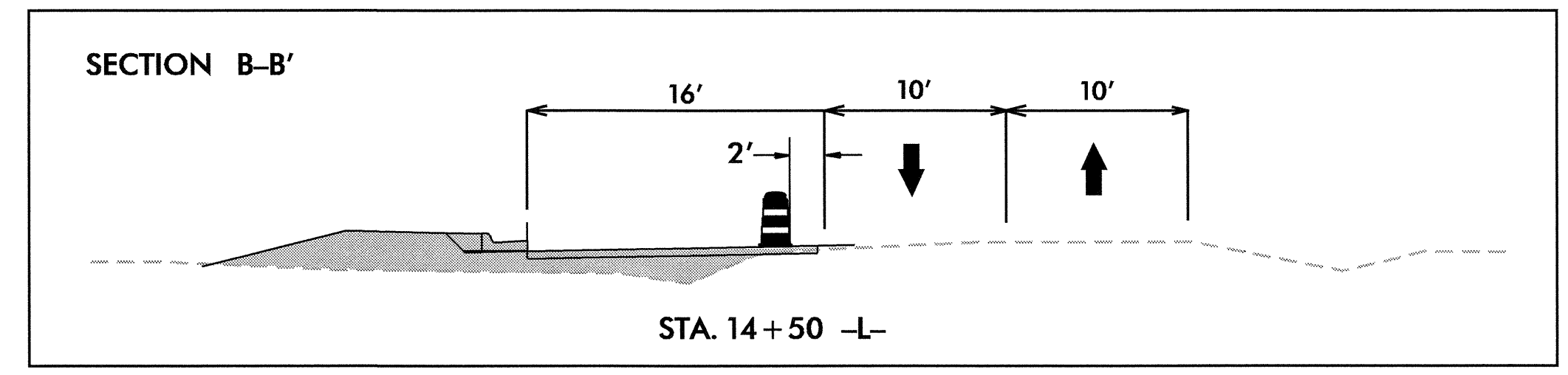

NOTE: ALL STATIONS ARE APPROXIMATE.

APPROVED: *[Signature]* DATE: 5/4/07

SEAL:

<b>PHASE I</b>		<b>REVISIONS</b>	
SCALE: NONE			
DATE:			
DESIGN BY: LKD			
REVIEWED BY: JWW			

07-MAY-2007 14:49 \\dot\dfsroot\01\Projects\RR4071\Traffic\Traffic\top\top03-phasel.dgn

**PHASE II**

STEP 1: USING FLAGGERS AND ROADWAY STANDARD DRAWING 1101.02, SHEET 1 OF 9, CONSTRUCT ROADWAY UP TO BUT NOT INCLUDING THE FINAL LAYER OF THE SURFACE COURSE ON:

- L- RIGHT STA 10+59+/- TO STA 19+22+/-
- L- RIGHT STA 19+62+/- TO STA 28+23+/-
- Y- LEFT STA 15+44+/- TO STA 17+40+/-
- Y2- RIGHT STA 10+33+/- TO STA 10+58+/-
- Y2- LEFT STA 10+21+/- TO STA 10+58+/-

STEP 2: COMPLETE THE WORK BEGUN IN PHASE I, STEP 3 AND PHASE I, STEP 4.

**PHASE III**

STEP 1: USING FLAGGERS AND ROADWAY STANDARD DRAWING NO. 1101.02, SHEET 1 OF 9, INSTALL FINAL LAYER OF THE SURFACE COURSE, FINAL PAVEMENT MARKINGS & MARKERS THROUGHOUT PROJECT.

STEP 2: INSTALL NEW SIGNAL AT -L- & -Y- (KEEN RDUS 301 INTERSECTION). ACTIVATE NEW SIGNAL & SHIFT TRAFFIC ONTO FINAL PATTERN. REMOVE ALL WORK ZONE SIGNS & TRAFFIC CONTROL DEVICES.

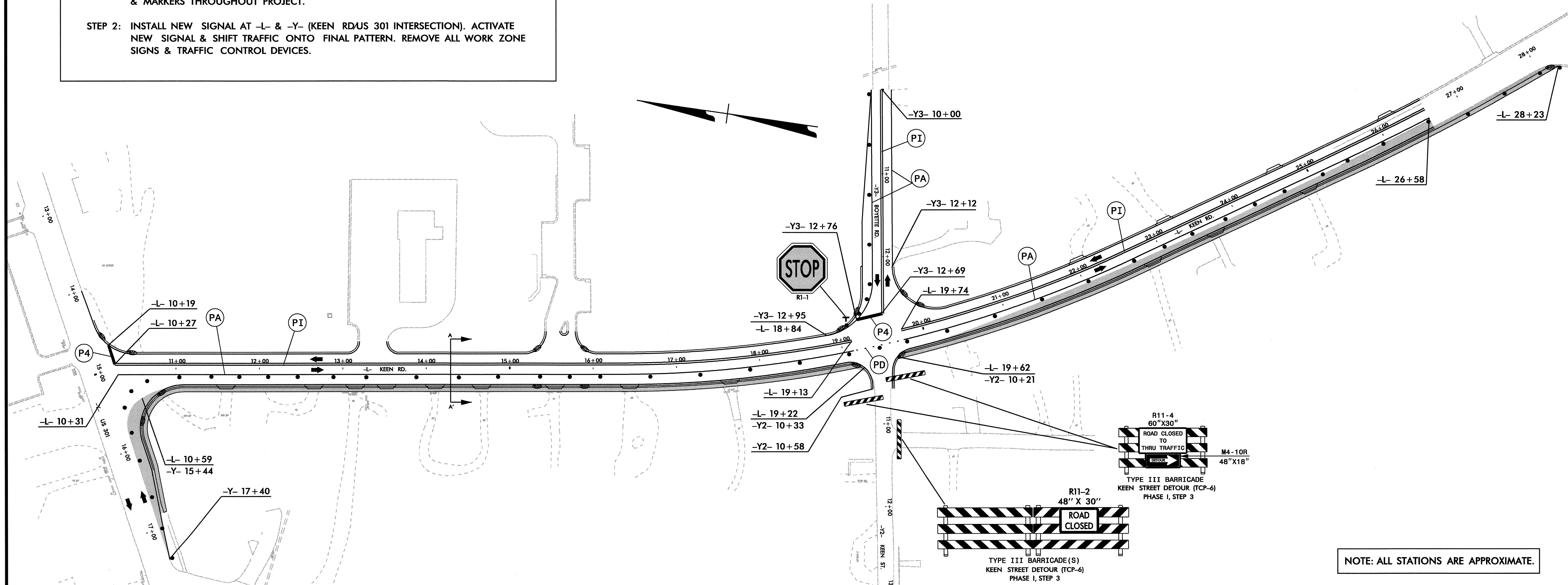
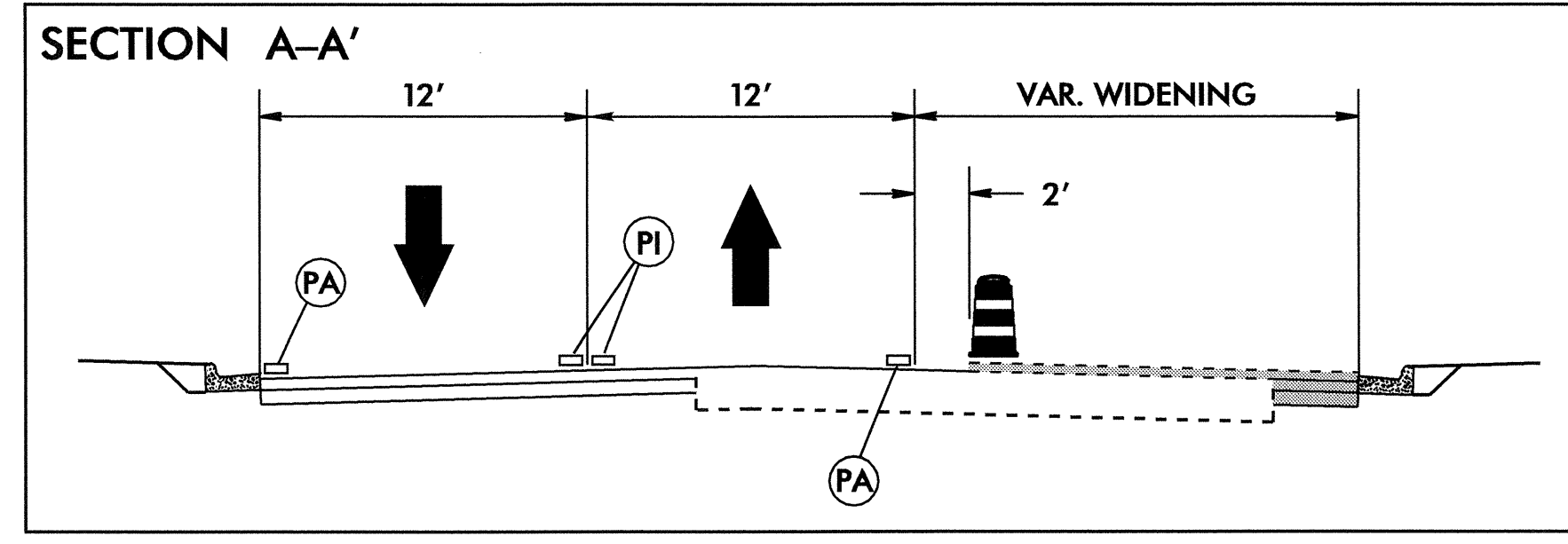

MATCHLINE SEE SHEET TCP-5

NOTE: MAINTAIN ACCESS TO ALL RESIDENCES AND BUSINESSES ON -Y2- (KEEN ST.) DURING CONSTRUCTION OF 42 INCH PIPE.

NOTE: ALL STATIONS ARE APPROXIMATE.

APPROVED: *J.W. Woolard* DATE: 5/19/07

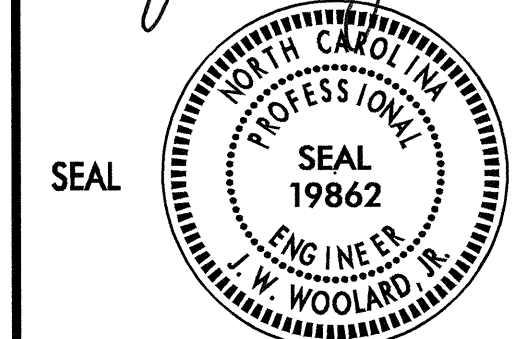

**PHASE II AND III**

SCALE: NONE		REVISIONS
DATE:		
DWG. BY: LKD		
DESIGN BY: LKD		
REVIEWED BY: JWW		

07-MAY-2007 14:49  
 \\dot\dfsroot\0\Proj\TIP\Projects-R\4071\TrafficControl\top\4071.tc\_top04\_phase2.dgn  
 donaldson AT WZTC21231



MATCHLINE SEE SHEET TCP-4

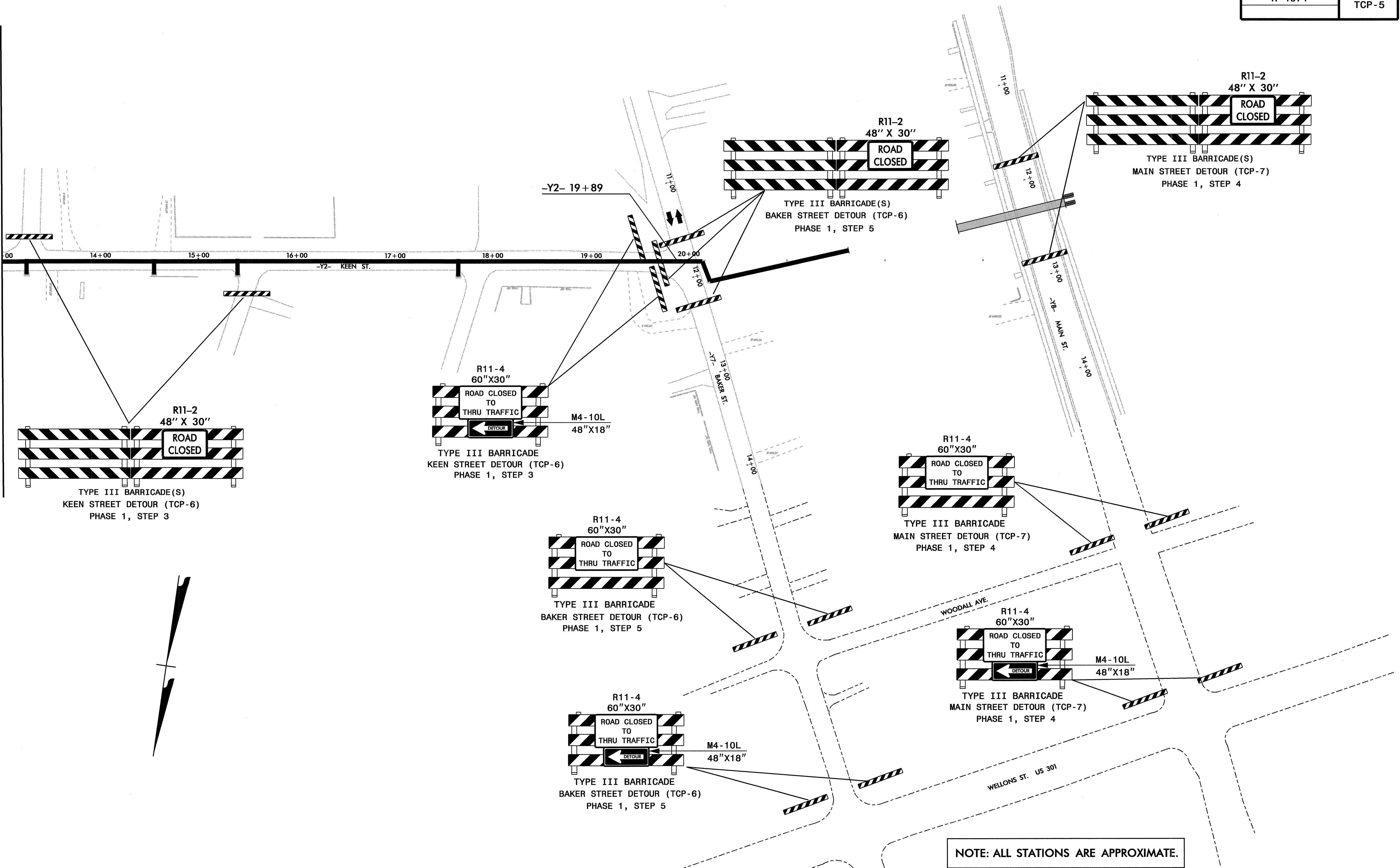

NOTE: MAINTAIN ACCESS TO ALL RESIDENCES AND BUSINESSES ON -Y2- (KEEN ST.) AND -Y7- (BAKER ST.) DURING CONSTRUCTION OF 42 INCH PIPE.

NOTE: ALL STATIONS ARE APPROXIMATE.

APPROVED: *J. W. Woodard* DATE: 5/18/07

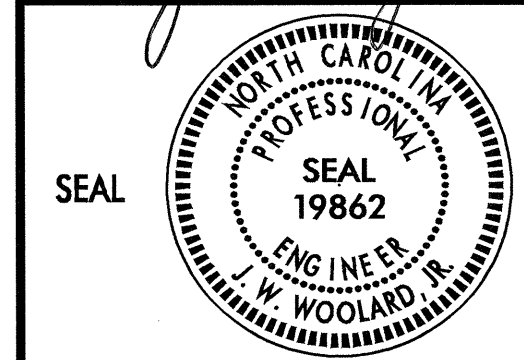

# PHASE I AND II

SCALE: NONE		REVISIONS
DATE:		
DWG. BY: LKD		
DESIGN BY: LKD		
REVIEWED BY: JWW		

07-MAY-2007 14:54 \\dot\dfs\oc\10\Proj\Projects\R4071\Traffic\TrafficControl\TopR-4071-rc\_tcp05\_phase2.dgn  
idonaldson AT WZTC21231

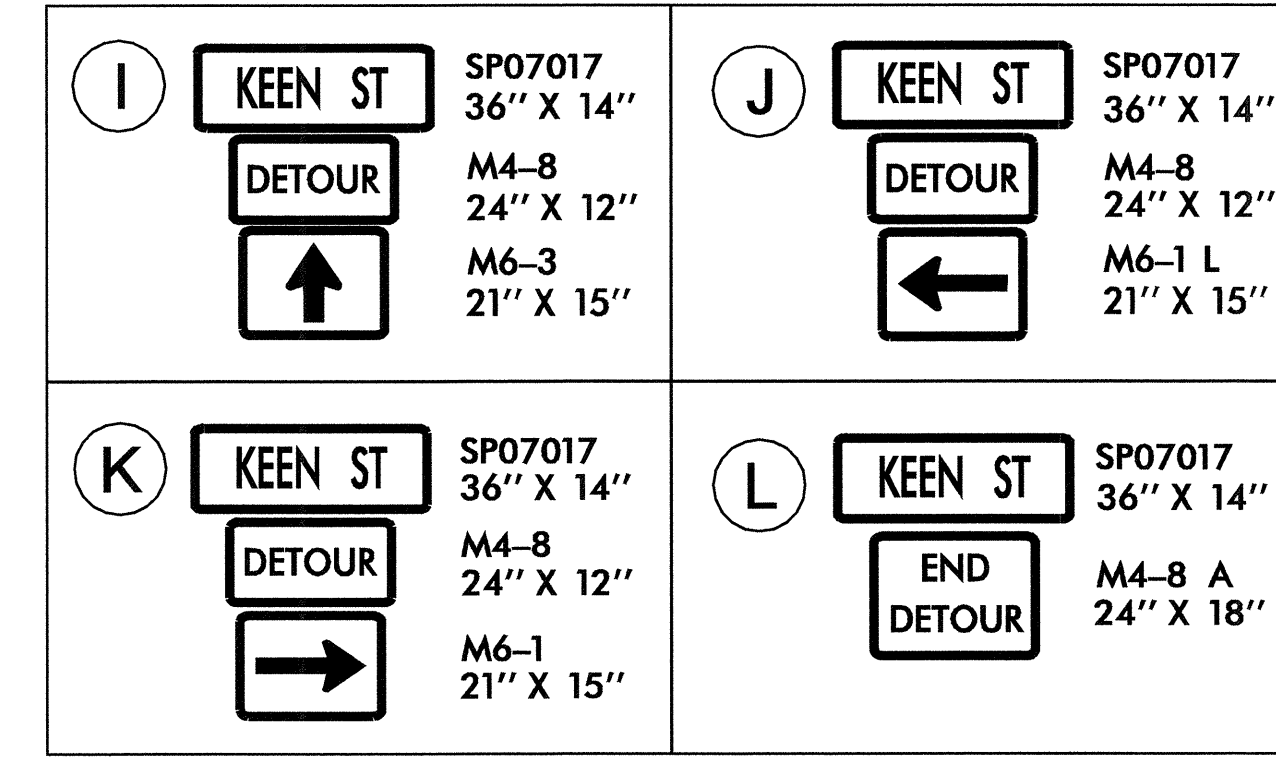
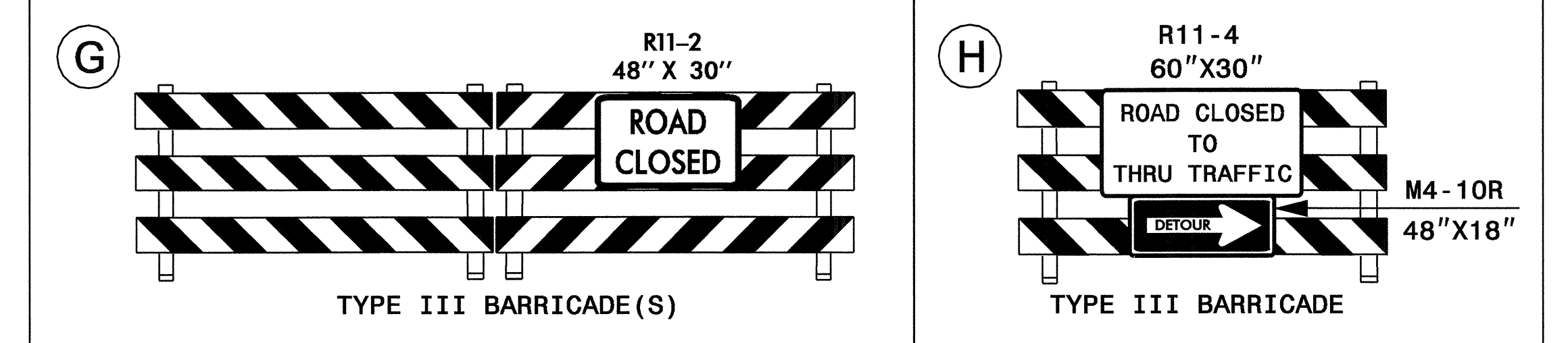
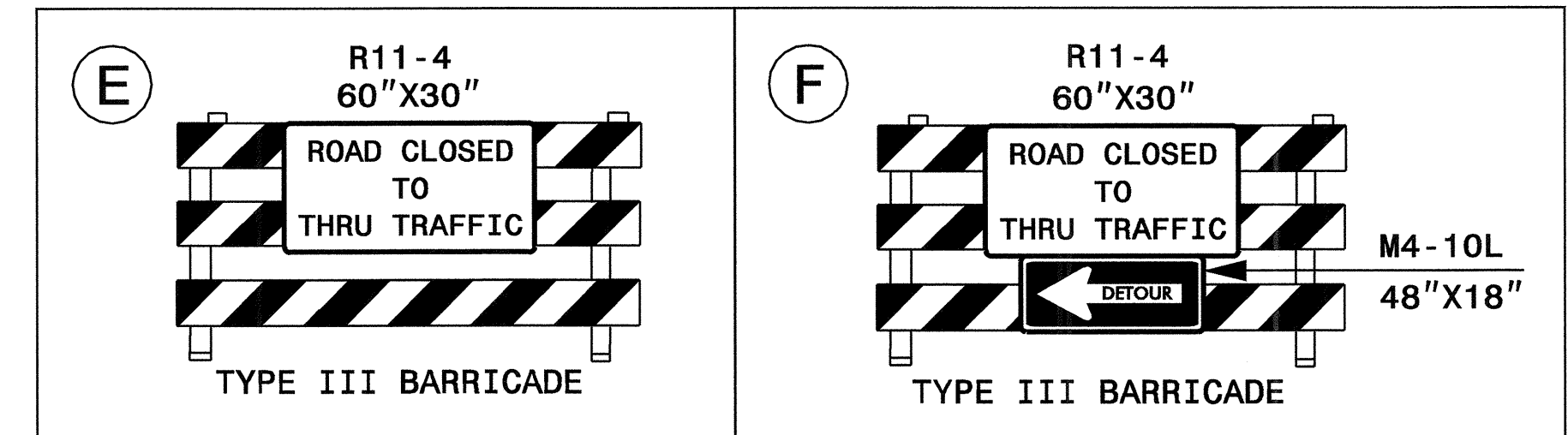
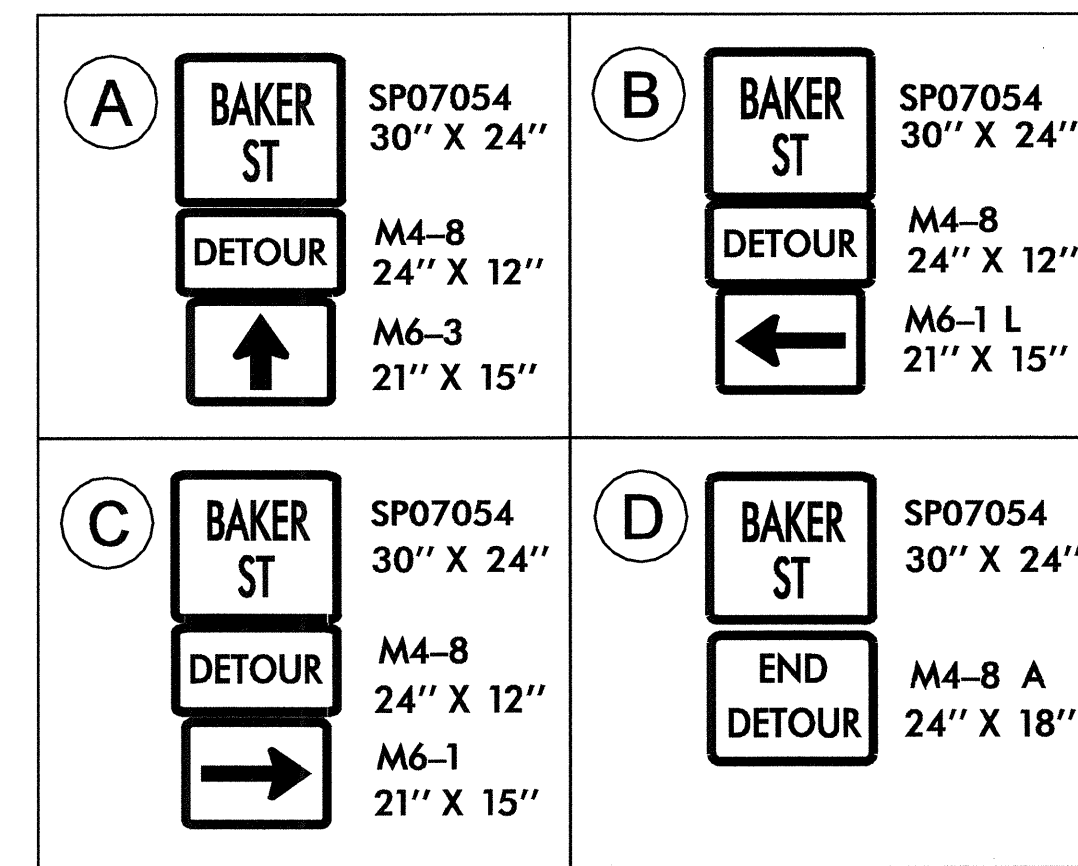
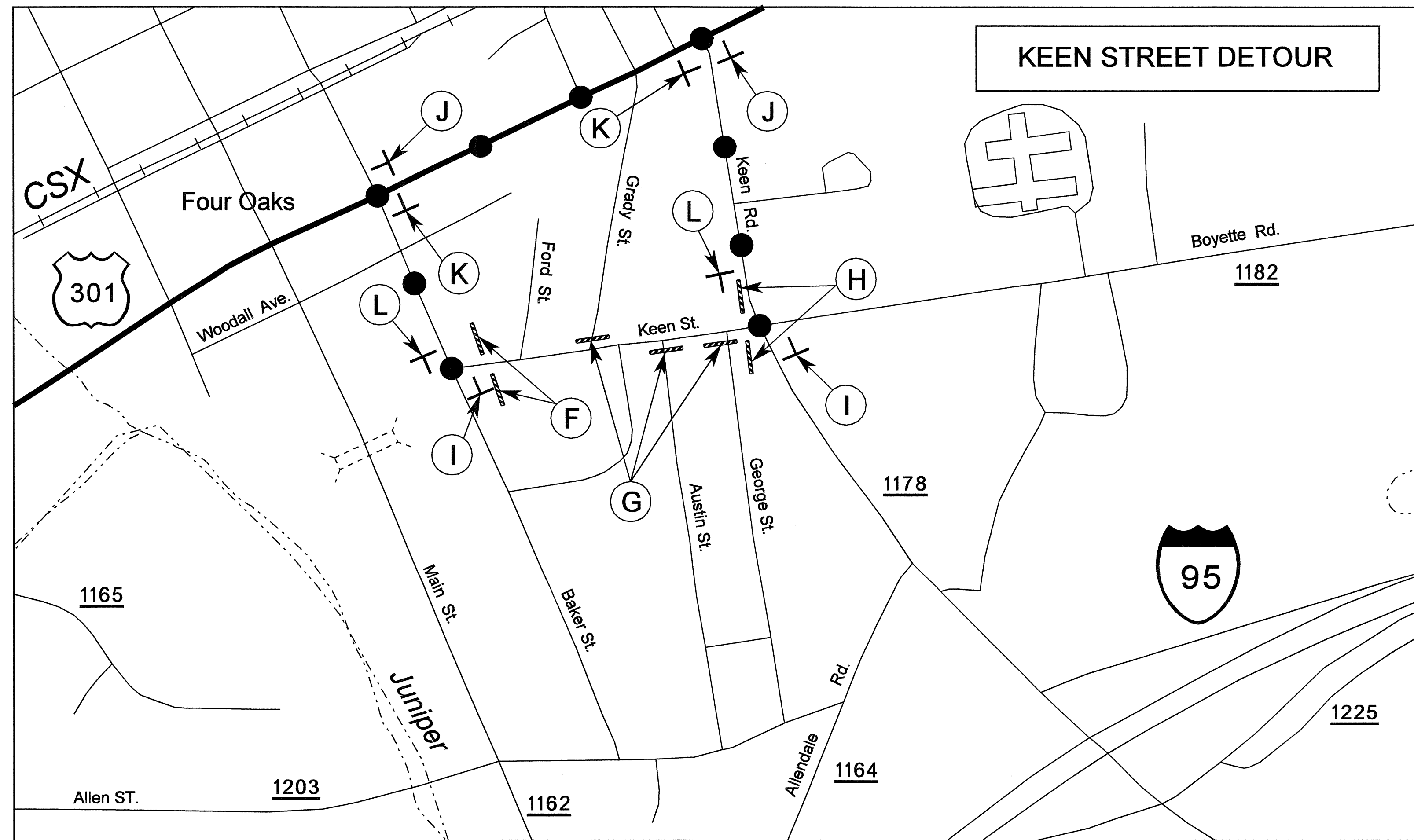
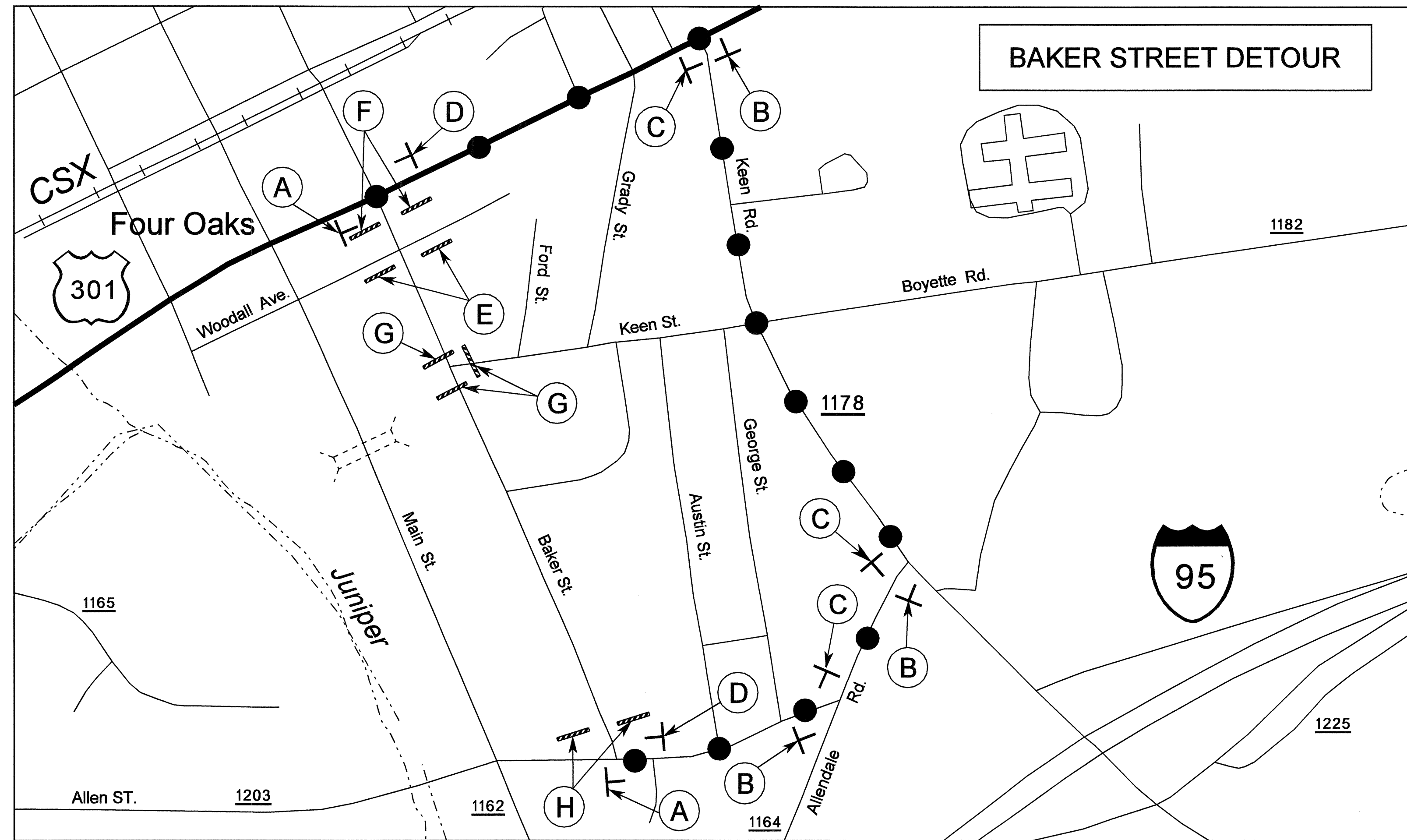

NOTE: SEE ROADWAY STANDARD DRAWING 1101.03, SHEETS 1 & 2 AND SHEETS TCP-4 AND TCP-5 FOR BARRICADE PLACEMENT.

NOTE: SEE SHEET TCP-9 FOR DETOUR SIGN DESIGNS.

APPROVED: <i>J.W. Woolard</i> DATE: 5/18/07		<b>BAKER STREET DETOUR KEEN STREET DETOUR</b>		
SEAL		SCALE: NONE	REVISIONS	
		DATE:		
		DWG. BY: LKD		
		DESIGN BY: LKD		
		REVIEWED BY: JWW		

07-MAY-2007 14:48  
 \\dot\dfsroot\01\Proj\TIP\Projects-R\4071\traffic\tratt\control\top\4071\c\_top06\_detour\_baker\_st.dgn  
 idonaldson AT WZTC21223

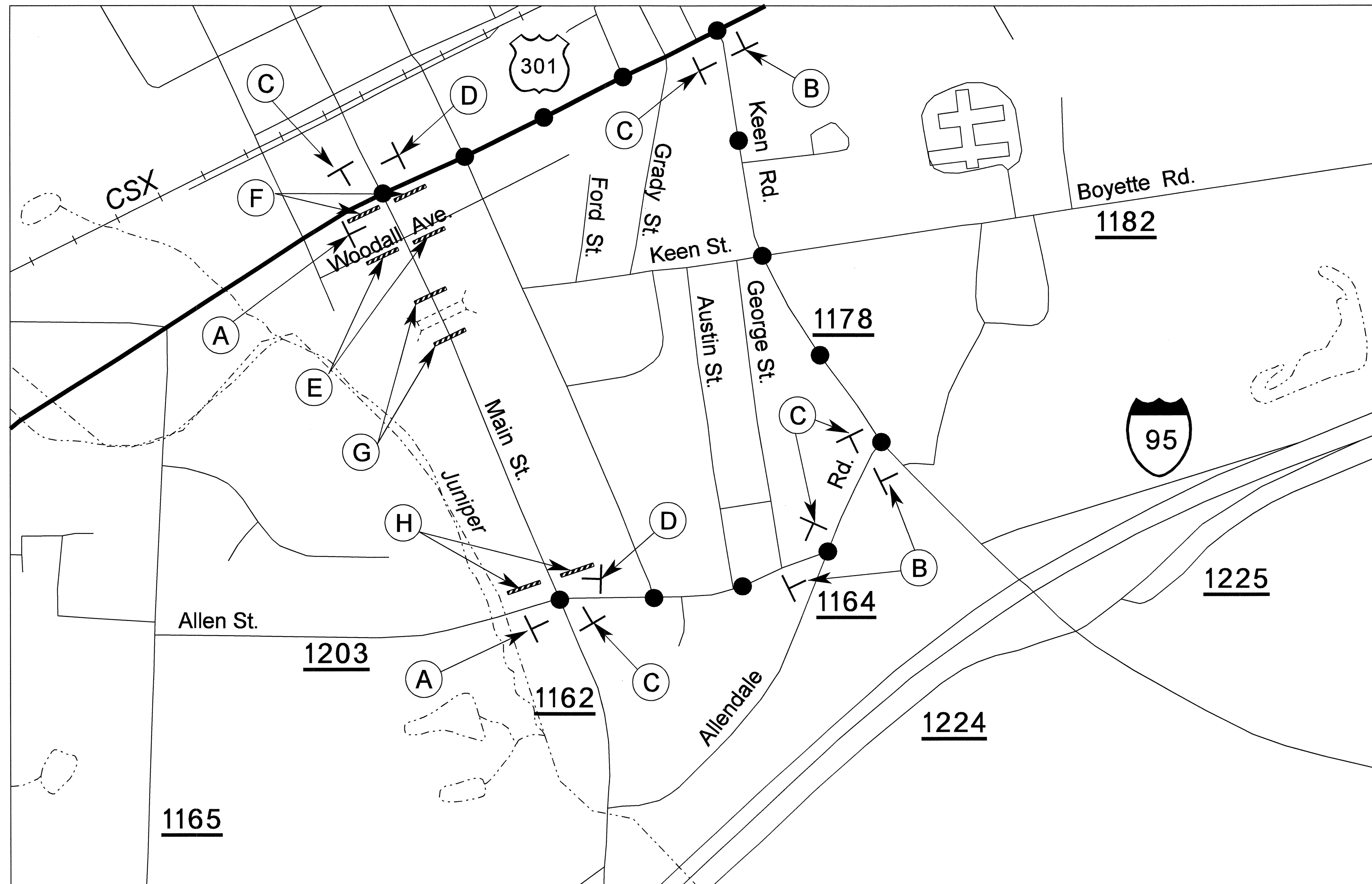

<b>(A)</b>	<b>MAIN ST</b>	SP07016 36" X 14"
	<b>DETOUR</b>	M4-8 24" X 12"
		M6-3 21" X 15"
<b>(B)</b>	<b>MAIN ST</b>	SP07016 36" X 14"
	<b>DETOUR</b>	M4-8 24" X 12"
		M6-1 L 21" X 15"
<b>(C)</b>	<b>MAIN ST</b>	SP07016 36" X 14"
	<b>DETOUR</b>	M4-8 24" X 12"
		M6-1 21" X 15"
<b>(D)</b>	<b>MAIN ST</b>	SP07016 36" X 14"
	<b>END DETOUR</b>	M4-8 A 24" X 18"

<b>(E)</b>	R11-4 60" X 30"		TYPE III BARRICADE
<b>(F)</b>	R11-4 60" X 30"		M4-10L 48" X 18"

NOTE: SEE ROADWAY STANDARD DRAWING 1101.03, SHEETS 1 & 2 AND SHEETS TCP-4 AND TCP-5 FOR BARRICADE PLACEMENT.

NOTE: SEE SHEET TCP-9 FOR DETOUR SIGN DESIGN.

<b>(G)</b>	R11-2 48" X 30"		TYPE III BARRICADE(S)
<b>(H)</b>	R11-4 60" X 30"		M4-10R 48" X 18"

APPROVED:	DATE: 5/9/07	<b>MAIN STREET DETOUR</b>	
SEAL 	SCALE: NONE		REVISIONS
	DATE: 2007 FEB		
	DWG. BY: LKD		
	DESIGN BY: LKD		
REVIEWED BY: JWW			CADD FILE

07-MAY-2007 14:48 \\dot\dfsroot\01\Proj\TIP\Projects-R\4071\TrafficControl\Top\4071.fc\_top07\_detour\_main.st.dgn idonaidson AT WZTC22231



**TWO-WAY UNDIVIDED & URBAN FREEWAYS (L-LINES)**

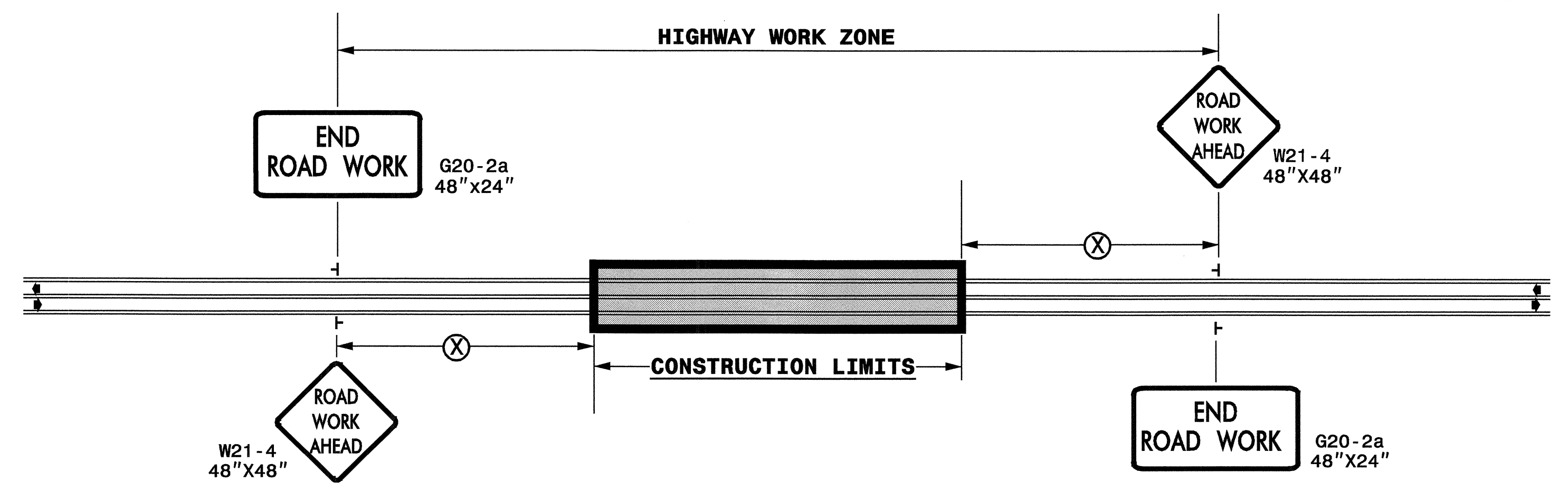

POSTED SPEED LIMIT (M.P.H.)	RECOMMENDED MINIMUM SIGN SPACING
≤ 50	500'
≥ 55	1000'

STATE OF NORTH CAROLINA  
DEPT. OF TRANSPORTATION  
DIVISION OF HIGHWAYS  
RALEIGH, N.C.

**ROADWAYS INTERSECTING ALONG 2 WAY UNDIVIDED WORK ZONE (Y-LINES)**

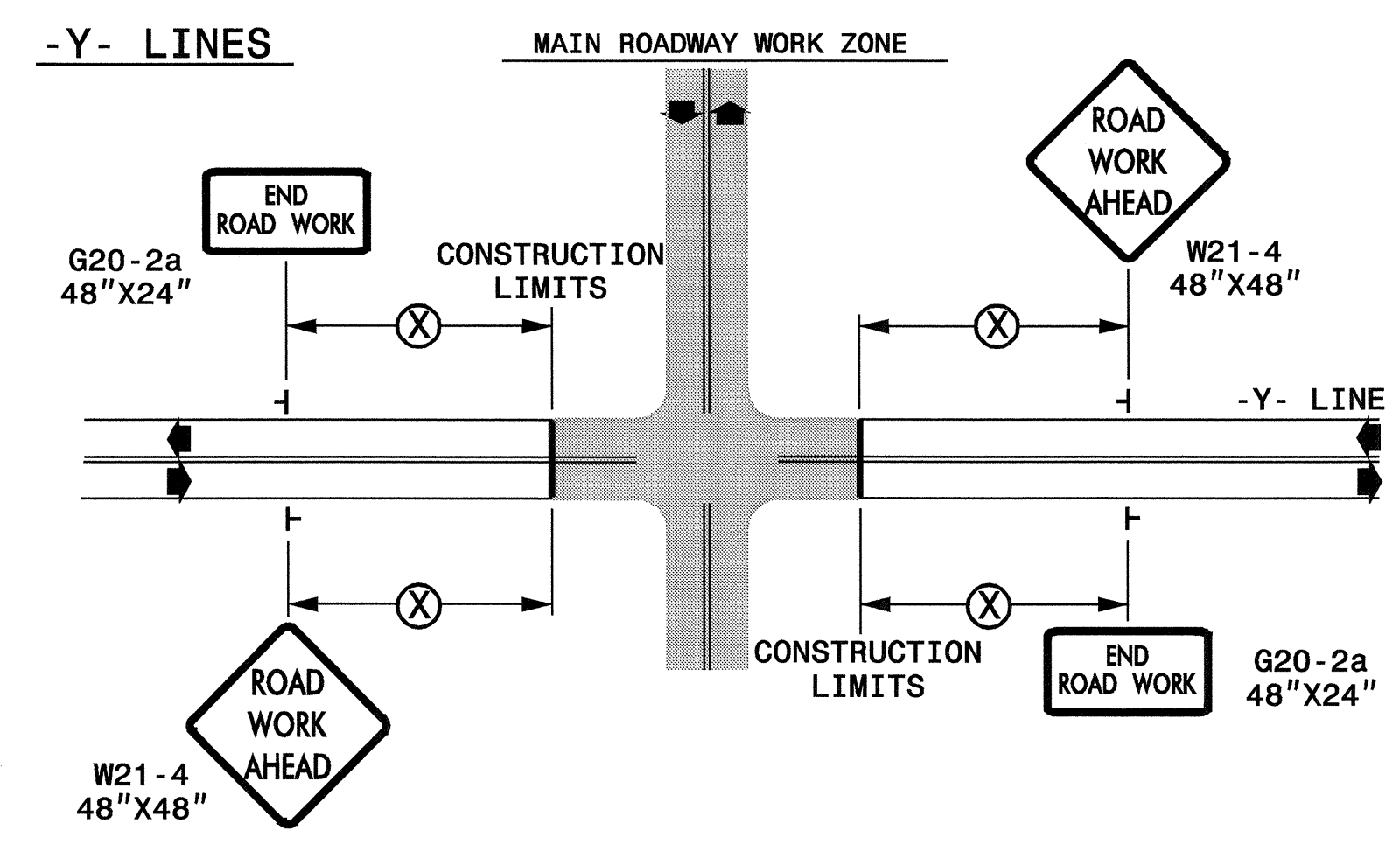

DETAIL DRAWING FOR  
TWO-WAY UNDIVIDED  
WORK ZONE WARNING SIGNS

**GENERAL NOTES**

- USE FLUORESCENT ORANGE SHEETING (TYPE VII OR IX) ON ALL ADVANCED WORK ZONE SIGNS.
- DO NOT INSTALL ADVANCE WARNING SIGNS MORE THAN 3 DAYS PRIOR TO BEGINNING OF WORK.
- SIGNS SHOWN ARE REQUIRED FOR WORK ZONES THAT WILL REMAIN IN EFFECT OVERNIGHT. FOR SHORT-TERM DAILY MAINTENANCE TYPE OPERATIONS, THIS SIGNING APPLICATION IS OPTIONAL; MAY USE ONLY APPLICABLE ROADWAY STANDARD DRAWINGS INSTEAD. HOWEVER, IF THIS SIGNING APPLICATION IS USED, SIGNS MAY BE PORTABLE MOUNTED.
- ALL SIGN SPACING DIMENSIONS ARE APPROXIMATE, FIELD ADJUST AS NECESSARY OR AS DIRECTED.
- USE 3LB STEEL U-CHANNEL POST OR 4" X 4" WOOD POST FOR ALL WORK ZONE SIGNS. 3LB STEEL U-CHANNEL POSTS MUST MEET THE REQUIREMENTS OF STANDARD SPECIFICATION SECTION 1094-1(B), MAY BE GALVANIZED STEEL, OR MAY BE PAINTED GREEN BY THE POST MANUFACTURER. SQUARE STEEL TUBING POSTS HAVING EQUIVALENT STRENGTH OF THE 3 LB STEEL U-CHANNEL POST ARE ALSO ACCEPTABLE FOR USE. ERECT SIGNS PER ROADWAY STANDARD DRAWING 1110.01. PAYMENT FOR WOOD POSTS, 3LB STEEL U-CHANNEL AND SQUARE STEEL TUBING POSTS WITH SIGNS WILL BE MADE ACCORDING TO STANDARD SPECIFICATION "WORK ZONE SIGNS" SECTION 1110.
- WHEN NECESSARY, USE SPLICING IN ACCORDANCE WITH ROADWAY STANDARD DRAWING NO. 1110.01. REMOVE ENTIRE POST WHEN REMOVING SIGNS WITH SPLICED POSTS.
- DO NOT BACK BRACE SIGN SUPPORTS.

**LEGEND**

┆ STATIONARY SIGN

◀ DIRECTION OF TRAFFIC FLOW

SHEET 1 OF 1

APPROVED: <i>J.W. Woolard</i> DATE: 5/9/07	DETAIL DRAWING FOR TWO-WAY UNDIVIDED AND URBAN FREEWAYS ADVANCED WORK ZONE WARNING SIGNS	
	SCALE: NONE	REVISIONS
	DATE:	7-98 10/01
	DWG. BY:	10-98 03/04
	DESIGN BY:	01/01
REVIEWED BY:	CADD FILE	

07-MAY-2007 14:47 \\dot\offsr\off\proj\TIP\proj\trafficocontrol\top\4071.fc\_top08\_wz\_signs.dgn idonldson AT WZTC21231

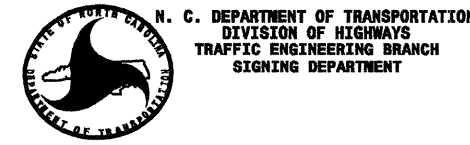

SIGN NUMBER: SP07016  
 TYPE: D  
 QUANTITY: 1  
 SIGN WIDTH: 36"  
 HEIGHT: 14"  
 TOTAL AREA: 3.5 Sq.Ft.  
 BORDER TYPE: FLUSH  
 RECESS: 0.38"  
 WIDTH: 0.63"  
 RADII: 1.5"  
 NO. Z BARS: 1  
 LENGTH: 1.5"  
 MAT'L: 0.080" (2.0 mm) ALUMINUM  
 0.079" COMPOSITE

DESIGN BY: R. HENNEIN  
 PROJECT ID: R-4071  
 CHECKED BY:  
 DIV: 4  
 STD #: N/A  
 DATE: Jan 23, 2007

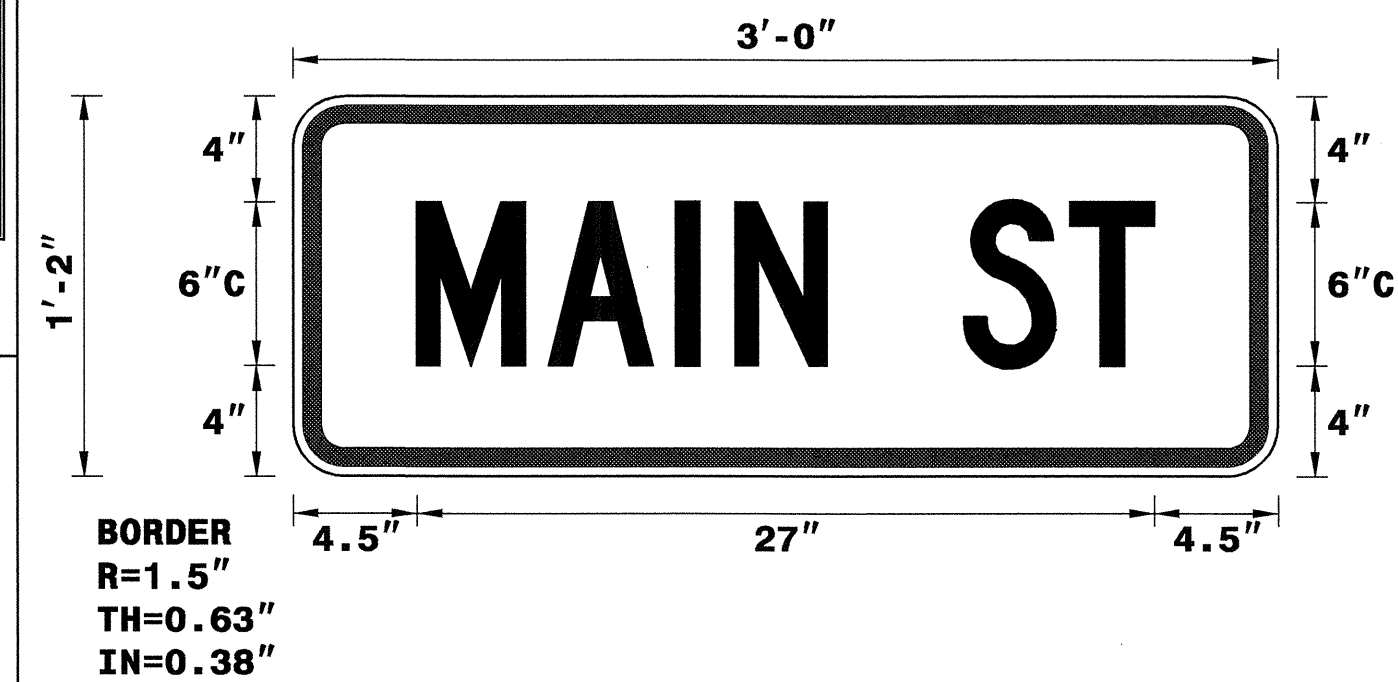

USE NOTES:  
 1. Legend and border shall be direct applied non-reflective sheeting.  
 2. Background shall be Type VII, VIII, or IX (prismatic) retroreflective sheeting.

LETTER POSITIONS

Letter spacings are to start of next letter										Series/Size Text Length
M	A	I	N	S	T					C 2000
4.5	4.8	4.7	2.2	3.4	5	3.9	3.1	4.5		27

Spacing Factor is 1 unless specified otherwise

FILENAME: SP07016\_ma1nst

NORTH CAROLINA D.O.T. SIGN DETAIL

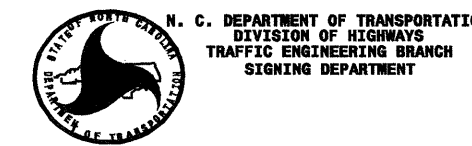

SIGN NUMBER: SP07054  
 TYPE: D  
 QUANTITY: 1  
 SIGN WIDTH: 30"  
 HEIGHT: 24"  
 TOTAL AREA: 5.0 Sq.Ft.  
 BORDER TYPE: FLUSH  
 RECESS: 0.38"  
 WIDTH: 0.63"  
 RADII: 1.5"  
 NO. Z BARS: 1  
 LENGTH: 1.5"  
 MAT'L: 0.080" (2.0 mm) ALUMINUM  
 0.079" COMPOSITE

DESIGN BY: R. HENNEIN  
 PROJECT ID: R-4071  
 CHECKED BY:  
 DIV: 4  
 STD #: N/A  
 DATE: Mar 02, 2007



USE NOTES:  
 1. Legend and border shall be direct applied non-reflective sheeting.  
 2. Background shall be Type VII, VIII, or IX (prismatic) retroreflective sheeting.

BORDER  
 R=1.5"  
 TH=0.63"  
 IN=0.38"

LETTER POSITIONS

Letter spacings are to start of next letter										Series/Size Text Length
B	A	K	E	R						C 2000
4.8	3.9	4.7	4.4	4.1	3.4	4.8				20.4
S	T									C 2000
11.5	3.9	3.1	11.5							7

Spacing Factor is 1 unless specified otherwise

FILENAME: SP07054\_bakerst

NORTH CAROLINA D.O.T. SIGN DETAIL

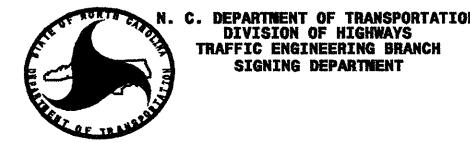

SIGN NUMBER: SP07017  
 TYPE: D  
 QUANTITY: 1  
 SIGN WIDTH: 36"  
 HEIGHT: 14"  
 TOTAL AREA: 3.5 Sq.Ft.  
 BORDER TYPE: FLUSH  
 RECESS: 0.38"  
 WIDTH: 0.63"  
 RADII: 1.5"  
 NO. Z BARS: 1  
 LENGTH: 1.5"  
 MAT'L: 0.080" (2.0 mm) ALUMINUM  
 0.079" COMPOSITE

DESIGN BY: R. HENNEIN  
 PROJECT ID: R-4071  
 CHECKED BY:  
 DIV: 4  
 STD #: N/A  
 DATE: Jan 23, 2007

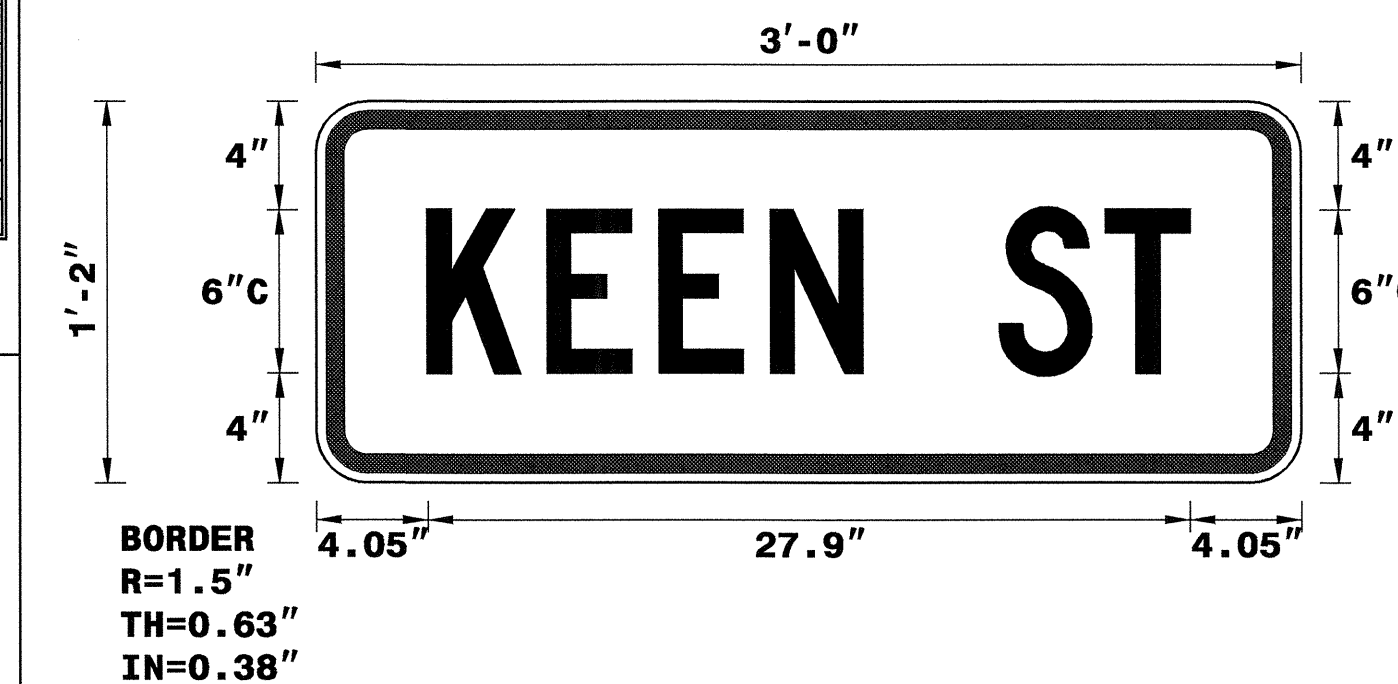

USE NOTES:  
 1. Legend and border shall be direct applied non-reflective sheeting.  
 2. Background shall be Type VII, VIII, or IX (prismatic) retroreflective sheeting.

LETTER POSITIONS

Letter spacings are to start of next letter										Series/Size Text Length
K	E	E	N	S	T					C 2000
4.1	4.4	4.1	4.1	3.4	5	3.9	3.1	4.1		27.9

Spacing Factor is 1 unless specified otherwise

FILENAME: SP07016\_ma1nst

NORTH CAROLINA D.O.T. SIGN DETAIL

07-MAY-2007 14:47  
 \\dot\dfsroot\01\Pro\Tip\Projects-R\R4071\traffic\trafficcontrol\top\4071\top09\_detour\signs.dgn  
 donaldson AT WZTC22231

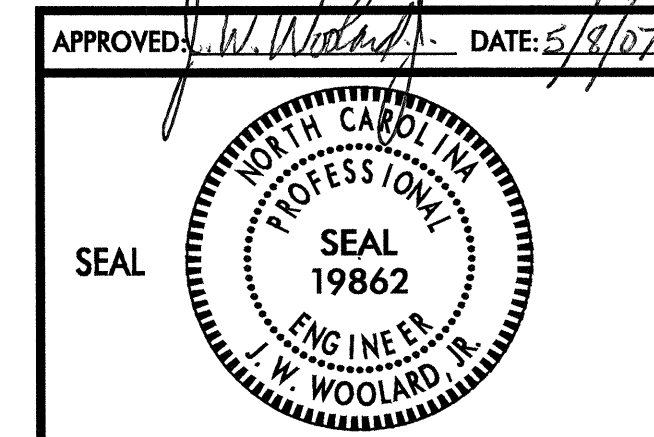

DETOUR SIGN DESIGNS

SCALE: NONE  
 DATE:  
 DWG. BY: LKD  
 DESIGN BY: LKD  
 REVIEWED BY: JWW

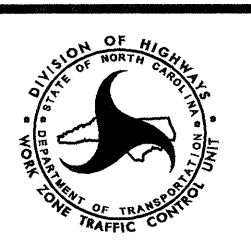

REVISIONS

CADD FILE