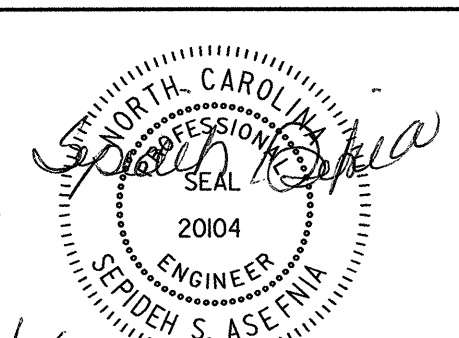
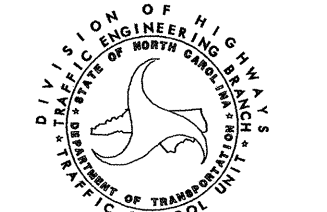

FINAL PAVEMENT MARKING SCHEDULE

SYMBOL	DESCRIPTION	PAY ITEM	PAY ITEM QUANTITY BREAKDOWN	TOTAL QUANTITY
	<u>PAVEMENT MARKINGS</u>			
		THERMOPLASTIC (4", 90 MILS)		
TA	WHITE EDGELINE		4458 LF TOTAL	4458 LF
		THERMOPLASTIC (4", 120 MILS)		
TI	YELLOW DOUBLE CENTER		4458 LF TOTAL	4458 LF
		COLD APPLIED PLASTIC (4")		
CA	WHITE EDGELINE		1942 LF	
CI	YELLOW DOUBLE CENTER		1942 LF TOTAL	3884 LF
		MARKERS		
		PERMANENT RAISED PAVEMENT MARKERS		
MA	YELLOW & YELLOW		12 EA TOTAL	12 EA
		SNOWPLOWABLE RAISED PAVEMENT MARKERS		
ME	YELLOW & YELLOW		28 EA TOTAL	28 EA

SEPI ENGINEERING GROUP
 2300 Rexwoods Drive
 Suite 370
 Raleigh, NC 27607
 Tel: 919-789-9977 Fax: 919-789-9591

APPROVED: _____ DATE: _____

 SEAL
 6/27/06

FINAL PAVEMENT MARKING SCHEDULE	
SCALE: NONE	
DATE: 6/06	REVISIONS
DESIGN BY: RCD	
DESIGN BY: RCD	
REVIEWED BY: RLW	
CADD FILE	

7/2/99

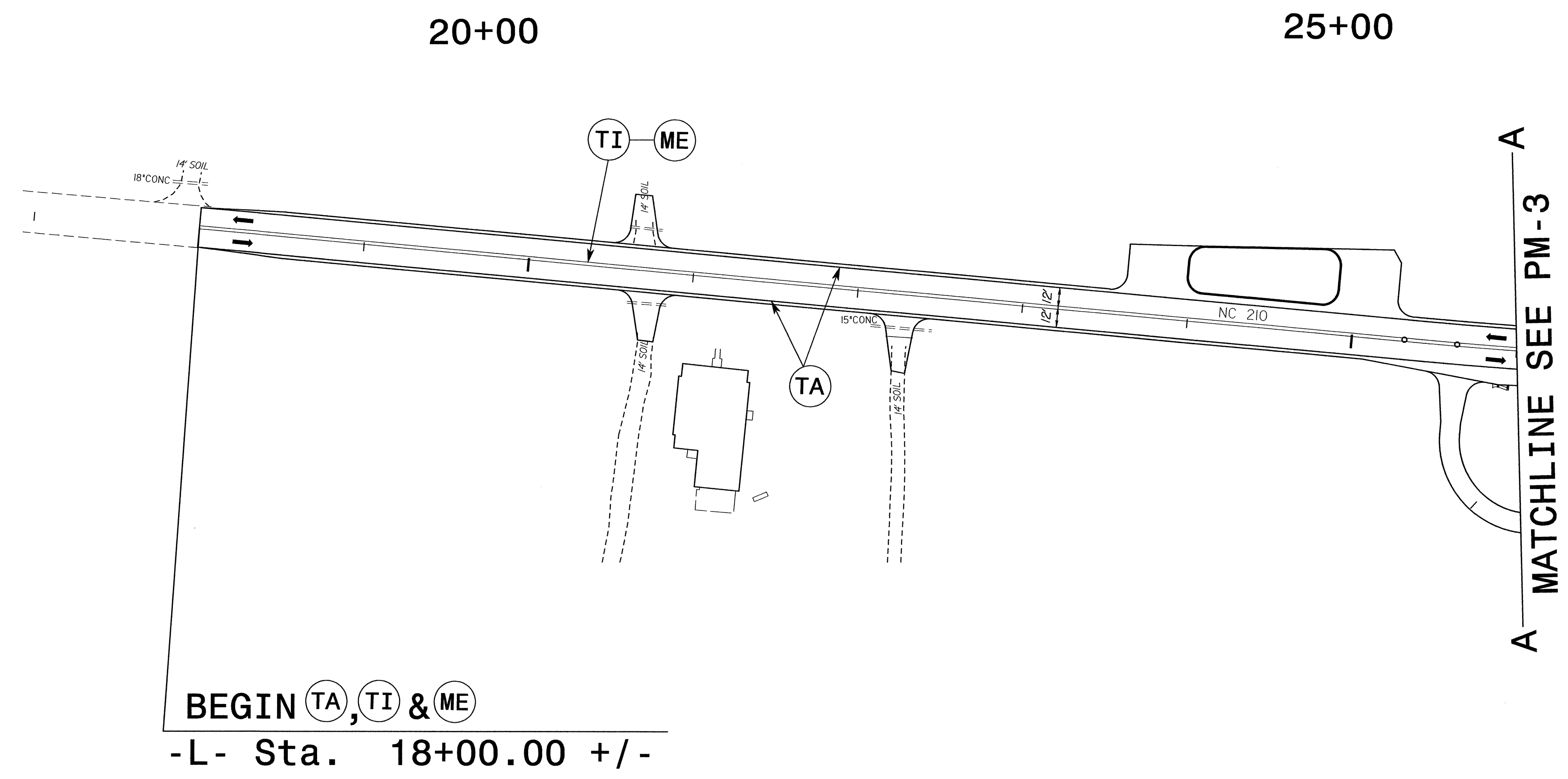
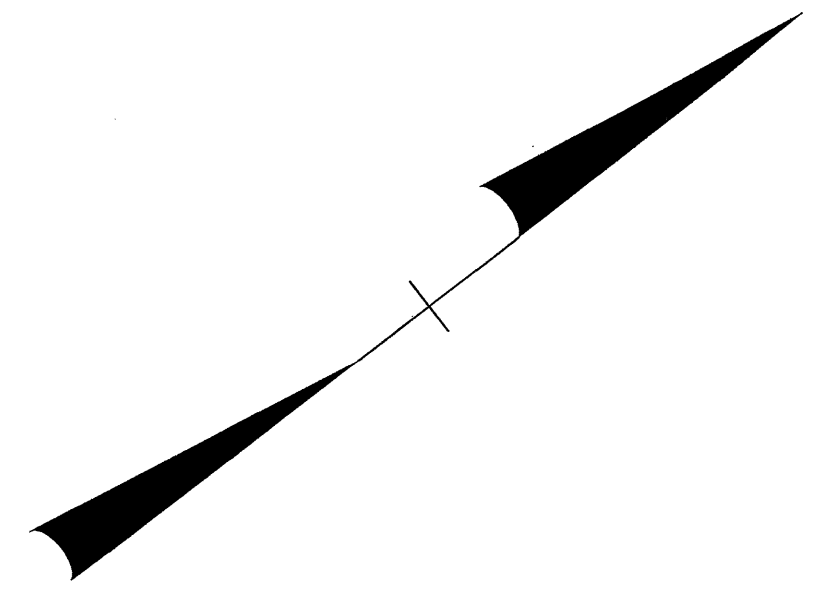
7/2/99



REFER TO PM-1 FOR FINAL PAVEMENT MARKING SCHEDULE

SEPI ENGINEERING GROUP
 2300 Rexwoods Drive
 Suite 370
 Raleigh, NC 27607
 Tel: 919-789-9977 Fax: 789-9591

APPROVED: _____ DATE: _____

 SEAL
 6/27/06

FINAL PAVEMENT MARKING PLANS									
SCALE: NONE									
DATE: 6/06									
DWG. BY: RCD									
DESIGN BY: RCD									
REVIEWED BY: RLW	<table border="1"> <tr> <th colspan="2">REVISIONS</th> </tr> <tr> <td> </td> <td> </td> </tr> <tr> <td> </td> <td> </td> </tr> <tr> <td> </td> <td> </td> </tr> </table>	REVISIONS							
REVISIONS									

7/2/99

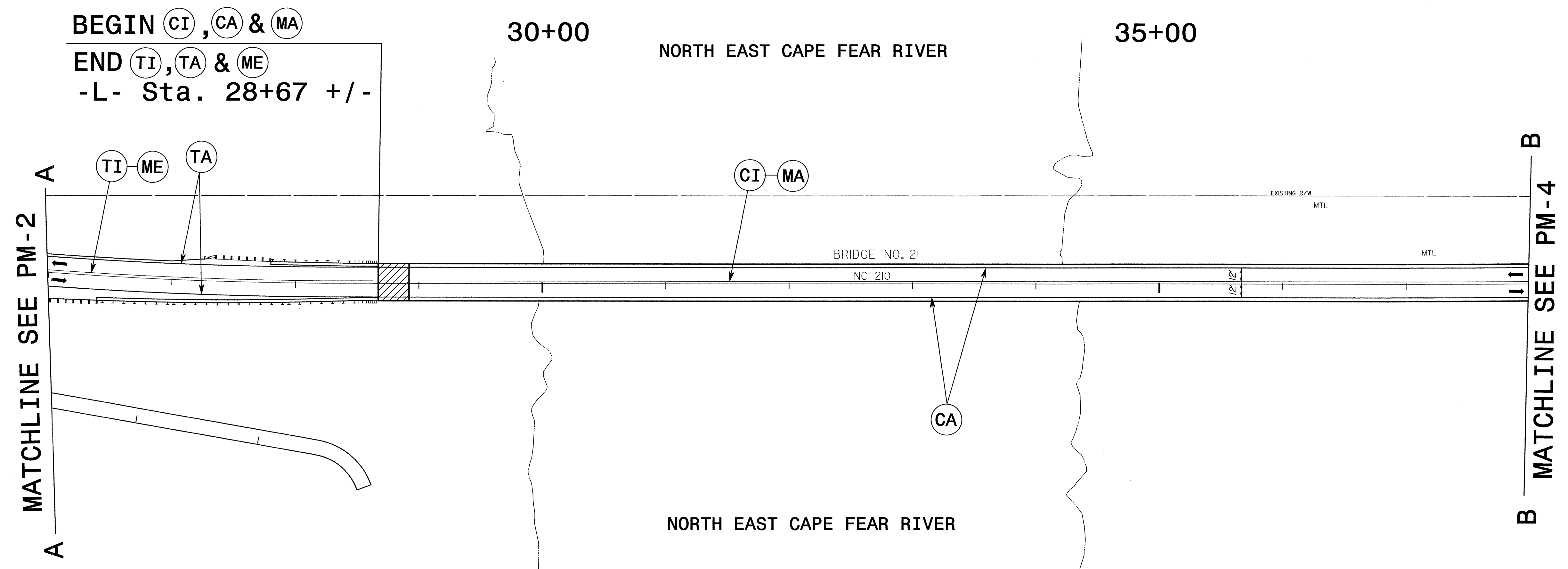
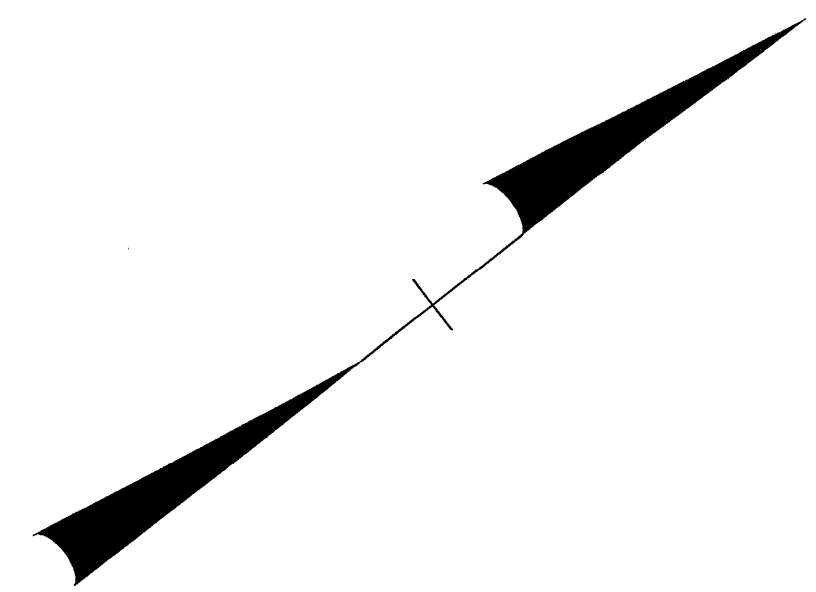

REFER TO PM-1 FOR FINAL PAVEMENT MARKING SCHEDULE

SEPI ENGINEERING GROUP
 2300 Rexwoods Drive
 Suite 370
 Raleigh, NC 27607
 Tel: 919-789-9977 Fax: 789-9591

APPROVED: _____ DATE: _____

 SEAL
 6/3/06

FINAL PAVEMENT MARKING PLANS

SCALE: NONE		REVISIONS
DATE: 6/06		
DWG. BY: RCD		
DESIGN BY: RCD		
REVIEWED BY: RLW		

7/2/09

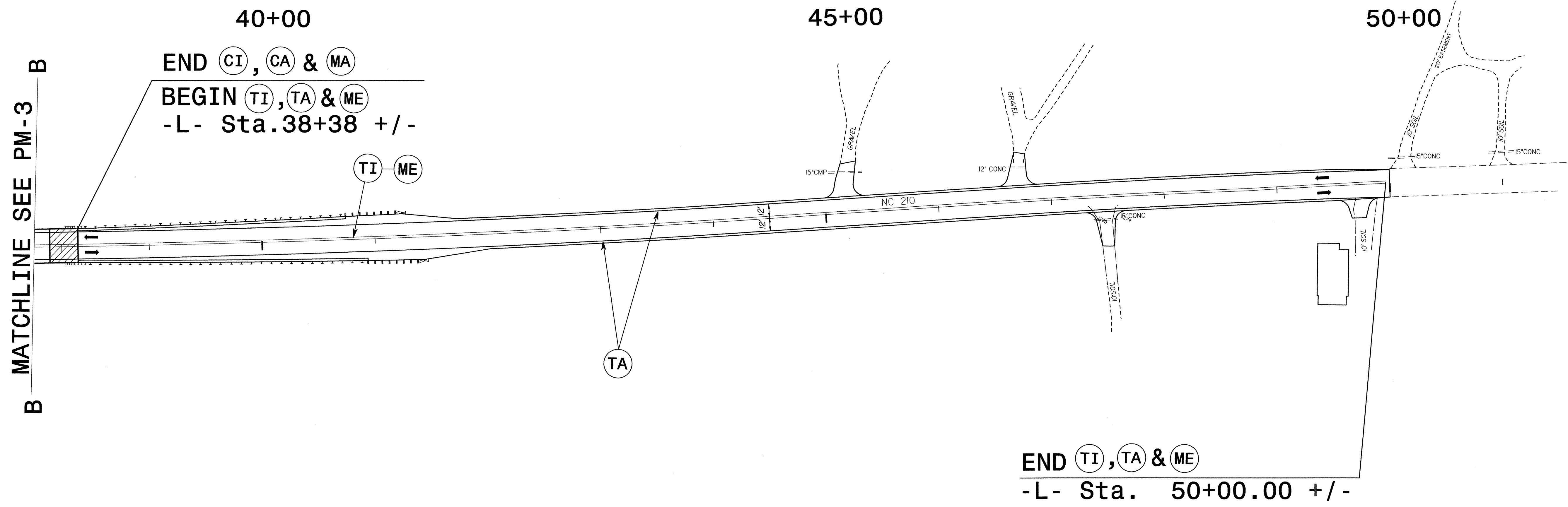
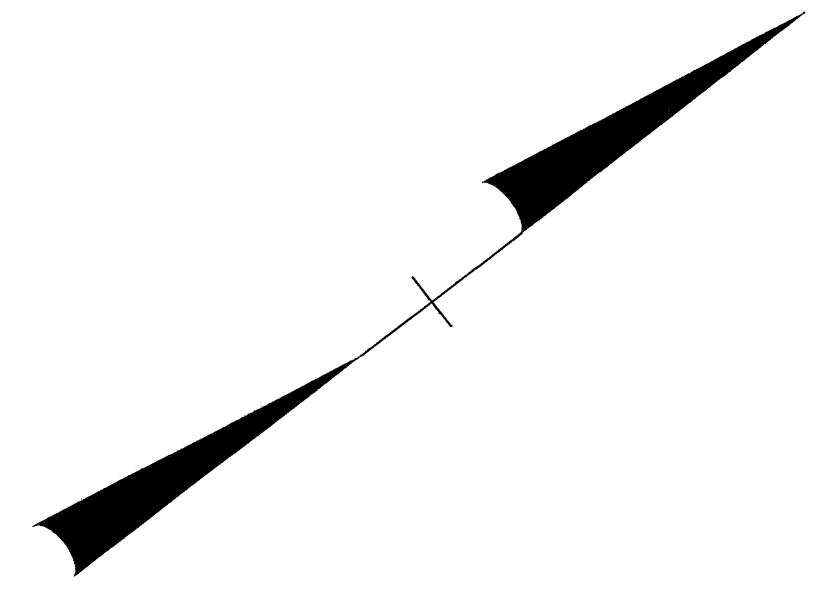

REFER TO PM-1 FOR FINAL PAVEMENT MARKING SCHEDULE

SEPI ENGINEERING GROUP
 2300 Rexwoods Drive
 Suite 370
 Raleigh, NC 27607
 Tel: 919-789-9977 Fax: 919-789-9591

APPROVED: _____ DATE: _____

 SEAL
 6/8/06

FINAL PAVEMENT MARKING PLANS

SCALE: NONE
 DATE: 6/06
 DWG. BY: RCD
 DESIGN BY: RCD
 REVIEWED BY: RLW

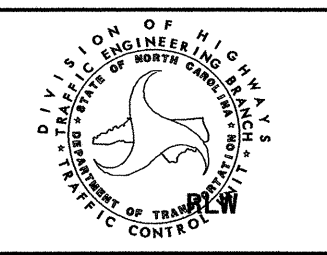

REVISIONS	