

**NOTES**

STIRRUPS IN CAP MAY BE SHIFTED AS NECESSARY TO CLEAR DOWELS.

THE LATERAL GUIDE AT EACH END OF CAP IS NOT TO BE POURED UNTIL AFTER CORED SLAB UNITS ARE IN PLACE.

THE CONTRACTOR SHALL PROVIDE FOR INSTALLATION OF THE 4" DIAMETER DRAIN PIPE THROUGH THE WING WALL AS REQUIRED FOR REINFORCED BRIDGE APPROACH FILLS, SEE THE ROADWAY PLANS. REINFORCING STEEL IN THE WING WALL MAY BE SHIFTED AS NECESSARY TO CLEAR THE DRAIN PIPE.

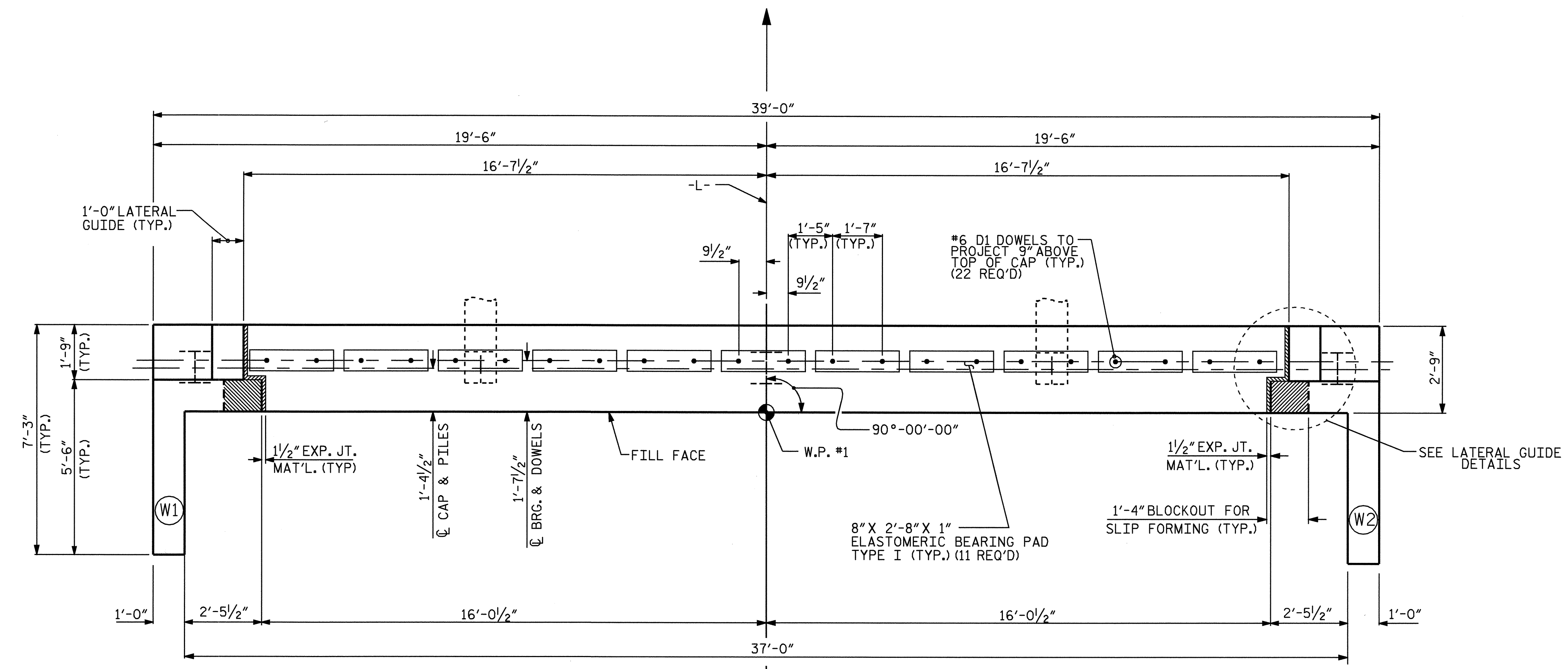

**PLAN**

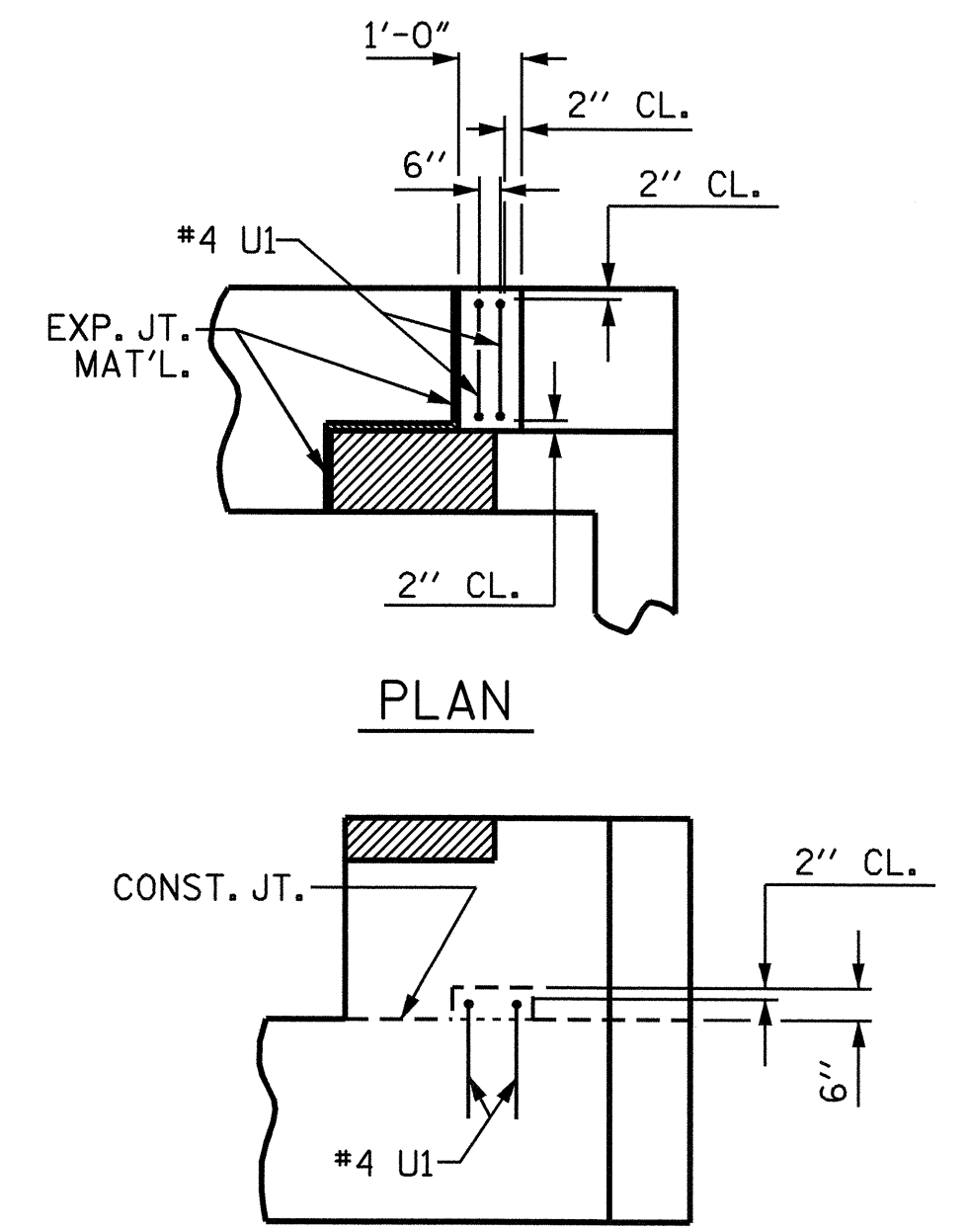

**LATERAL GUIDE DETAILS**  
(EACH END SIMILAR)

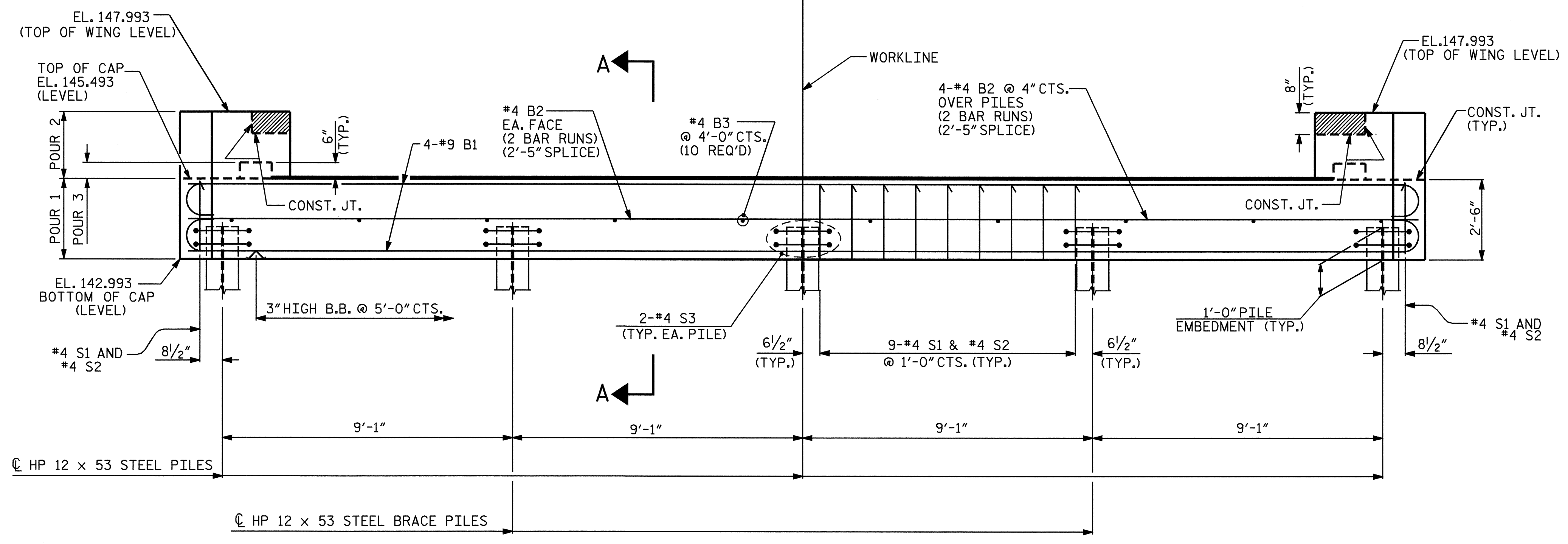

**ELEVATION**  
(WINGS NOT SHOWN IN PLAN VIEW)

PROJECT NO. B-4152  
HOKE COUNTY  
STATION: 14+70.00 -L-

SHEET 1 OF 3

STATE OF NORTH CAROLINA  
DEPARTMENT OF TRANSPORTATION  
RALEIGH

**SUBSTRUCTURE  
END BENT #1**

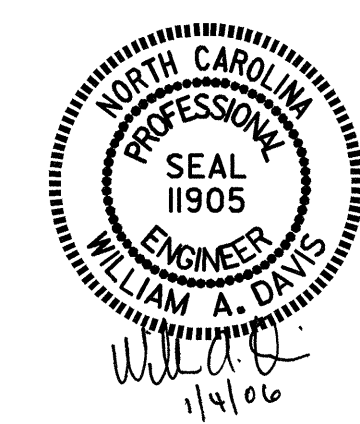

DRAWN BY : J. G. KHARVA DATE : 08/16/05  
CHECKED BY : BOB WRIGHT DATE : 08/18/05

REVISIONS						SHEET NO.
NO.	BY:	DATE:	NO.	BY:	DATE:	S-13
1			3			TOTAL SHEETS
2			4			26