

TYPICAL SECTION NO. 9

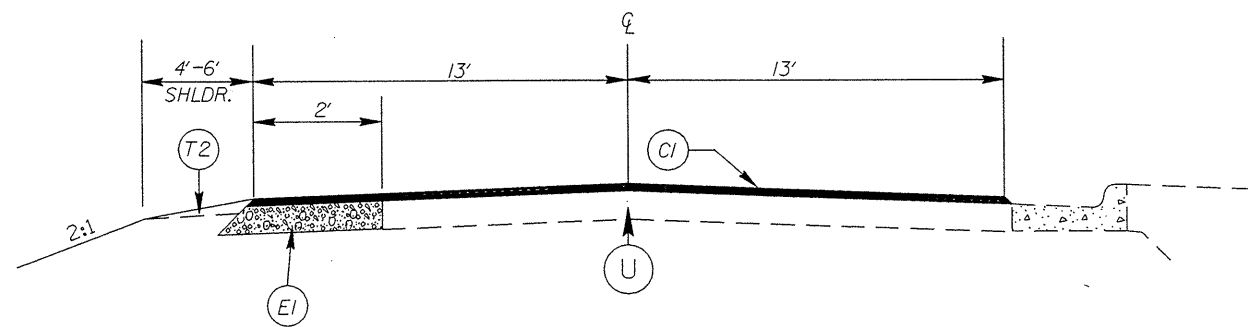

TYPICAL SECTION NO. 8

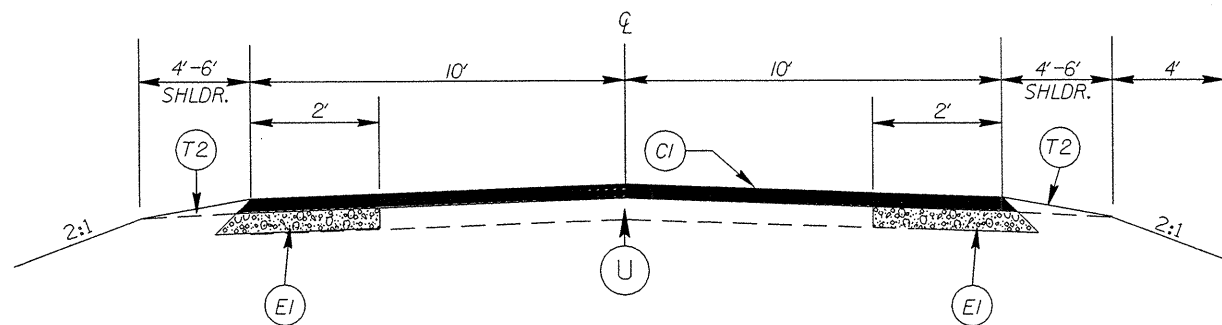

TYPICAL SECTION NO. 7

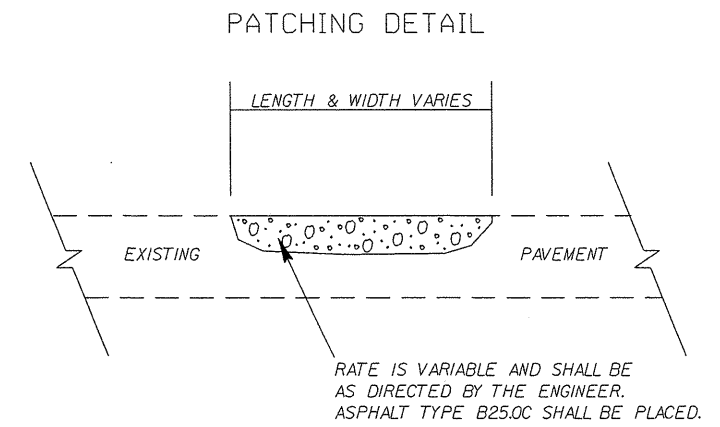

PAVEMENT SCHEDULE

(C1)	PROP. APPROX. 1.5" ASPHALT CONC. SURFACE COURSE, TYPE S9.5C, AT AN AVERAGE RATE OF 168 LBS. PER SQ. YD.
(E1)	PROP. APPROX. 5" ASPHALT CONC. BASE COURSE, TYPE B25.0C, AT AN AVERAGE RATE OF 570 LBS. PER SQ. YD.
(T1)	SHOULDER RECONSTRUCTION
(T2)	SHOULDER CONSTRUCTION
(U)	EXISTING PAVEMENT

NOTES: ON MAP #8 USE TYPICAL #10 FROM THE END OF THE C&G TO SILVER ORE LN. APPROX. 0.16 MILES.
ON MAP#3 SKIP THE TURN LANES AT STEELE CREEK CORP. CENTER (VIRKLER DR.) APPROX. 0.25 MILES.

MECKLENBURG COUNTY RESURFACING

SCALE	-NA-		REVISIONS
DATE			
DWG. BY	TWB		
DESIGN BY			
APPROVED			