

HALF SECTION @
POST-TENSIONING LOCATIONS

HALF SECTION @ END BENT

TYPICAL SECTION

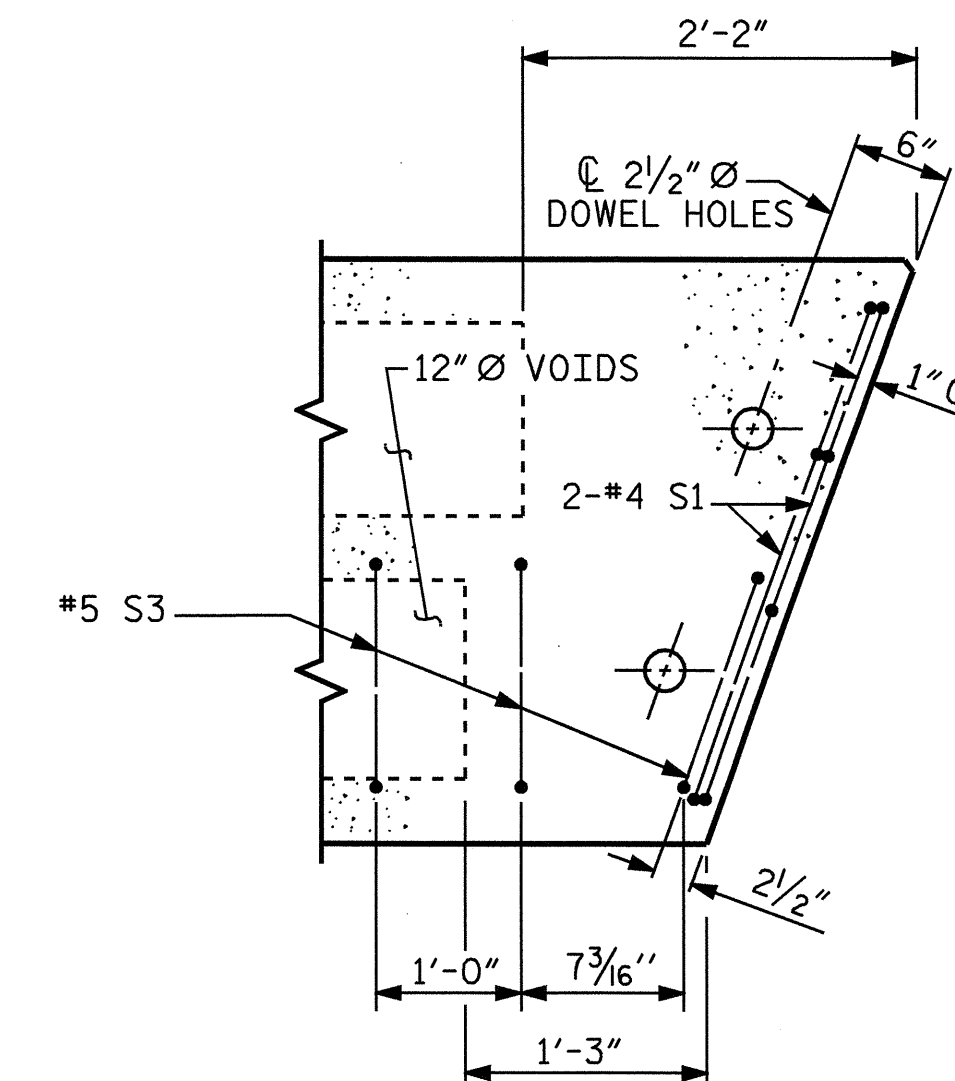

PART PLAN-EXTERIOR SECTION

NOTE: EXTERIOR SECTION SHOWN-INTERIOR SECTION SIMILAR EXCEPT OMIT S3 BARS.

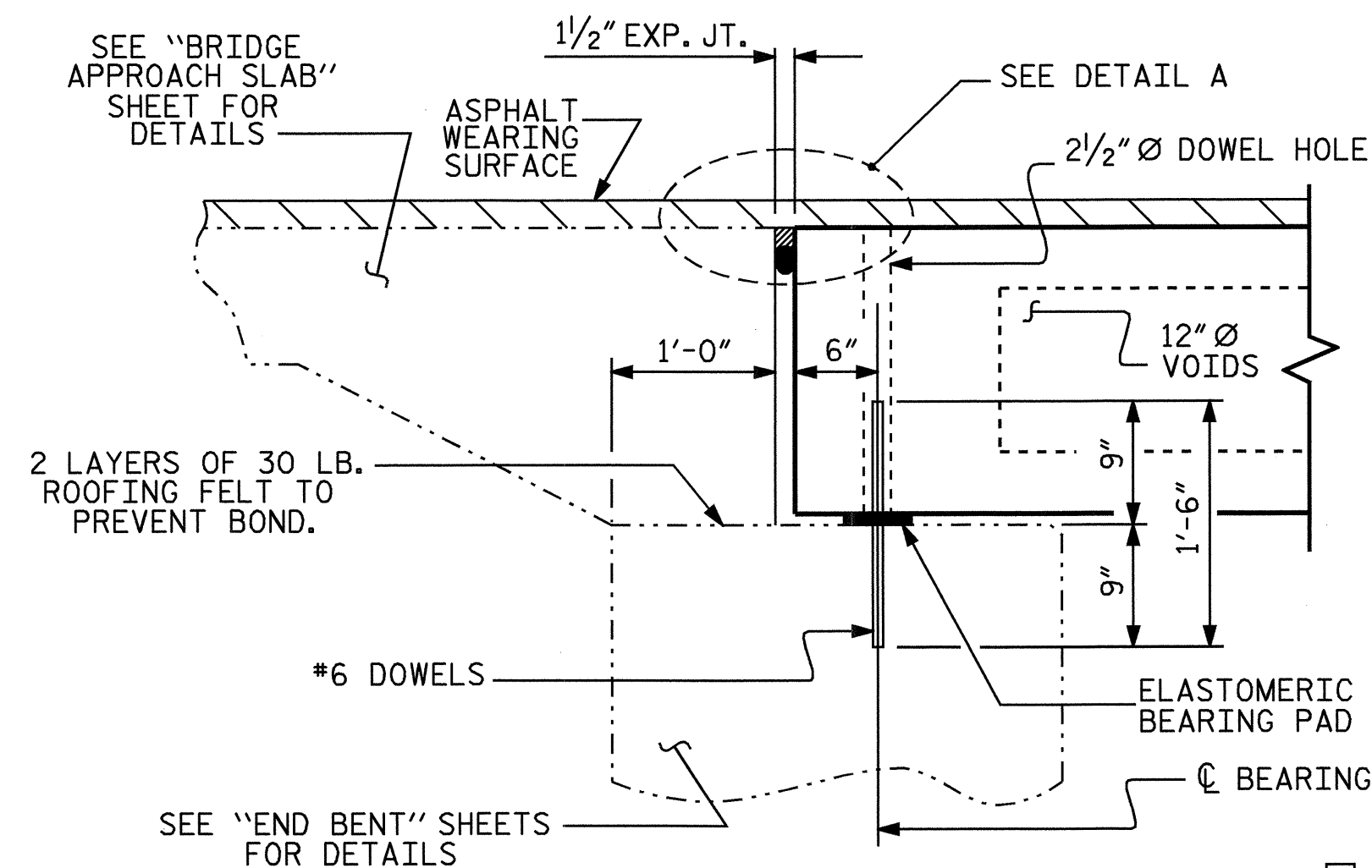

SECTION AT END BENT

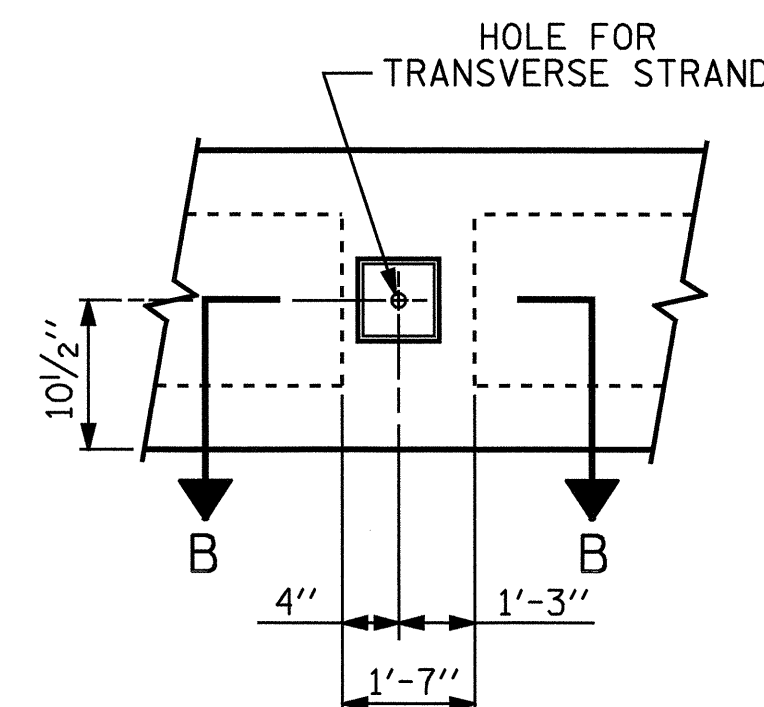

ELEVATION VIEW

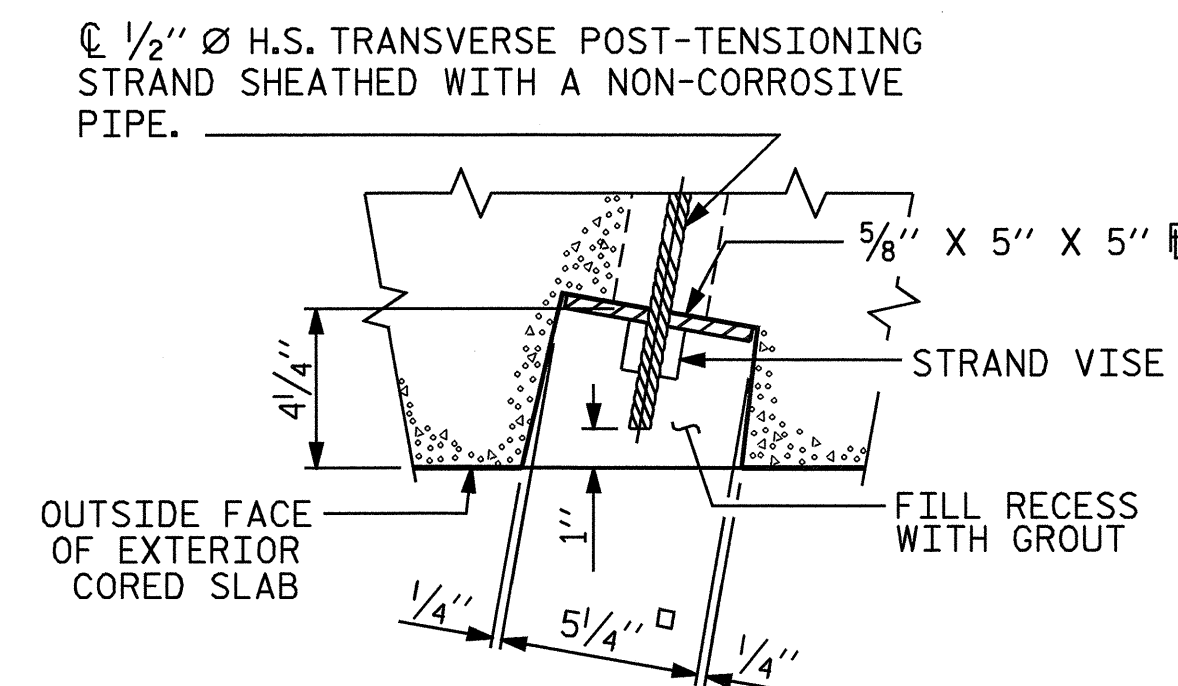

SECTION B-B

GROUTED RECESS AT END OF
POST-TENSIONED STRAND CORED SLABS

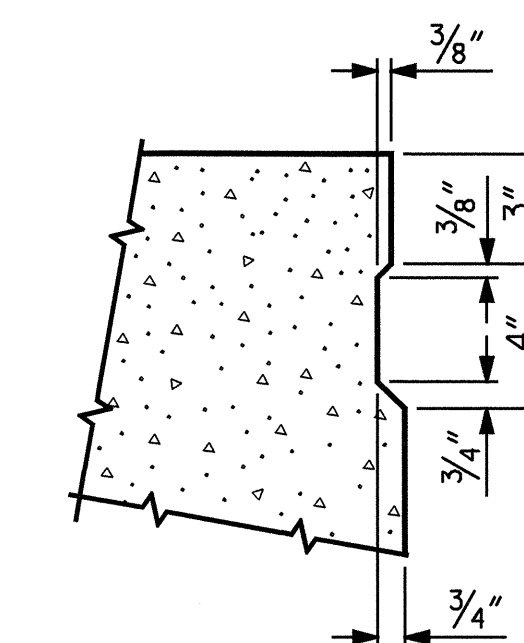

SHEAR KEY DETAIL

NOTE: OMIT SHEAR KEY ON OUTSIDE FACE
OF EXTERIOR CORED SLABS.

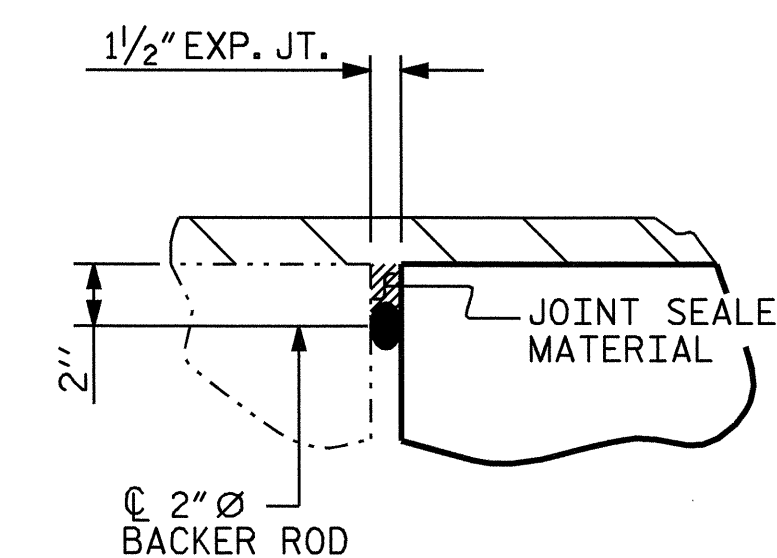

DETAIL A

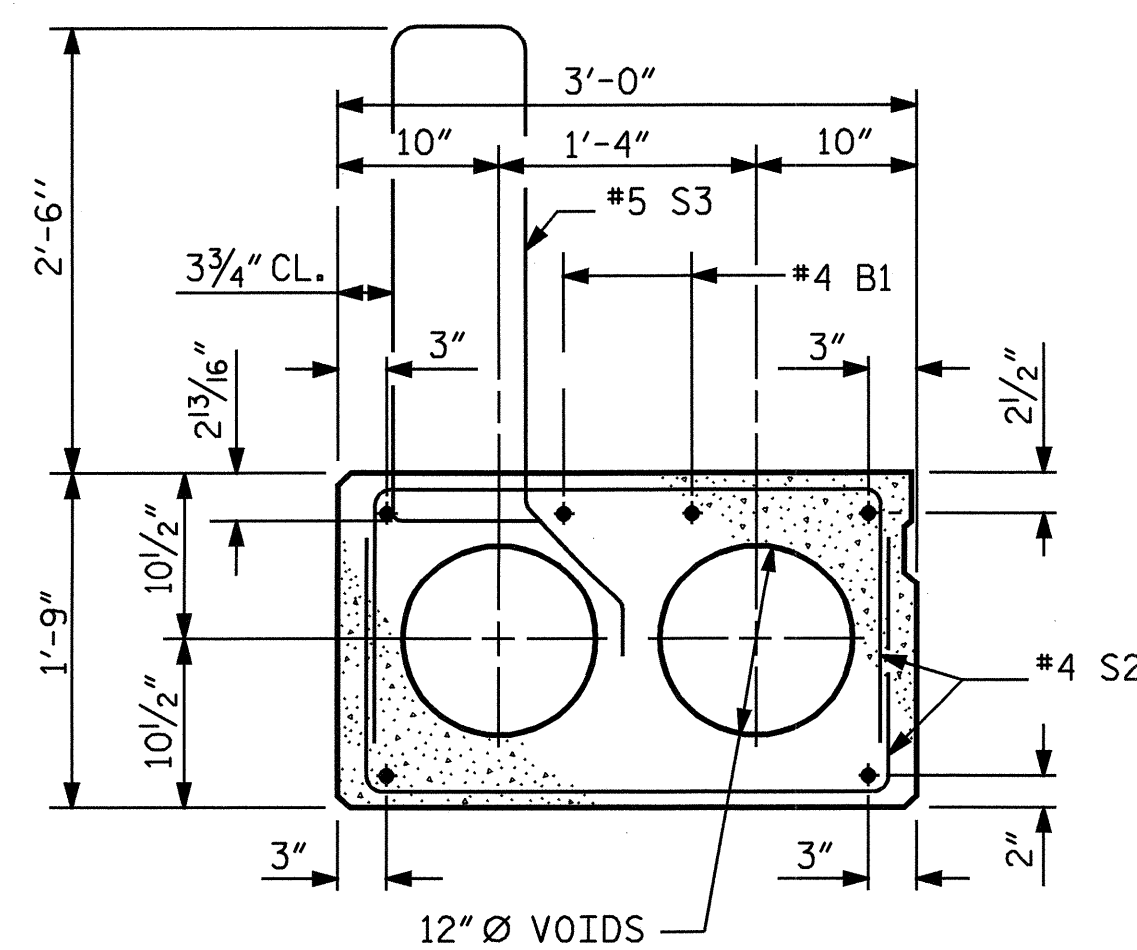

EXTERIOR SLAB SECTION

(FOR PRESTRESSED STRAND LAYOUT, SEE
INTERIOR SLAB SECTION.)

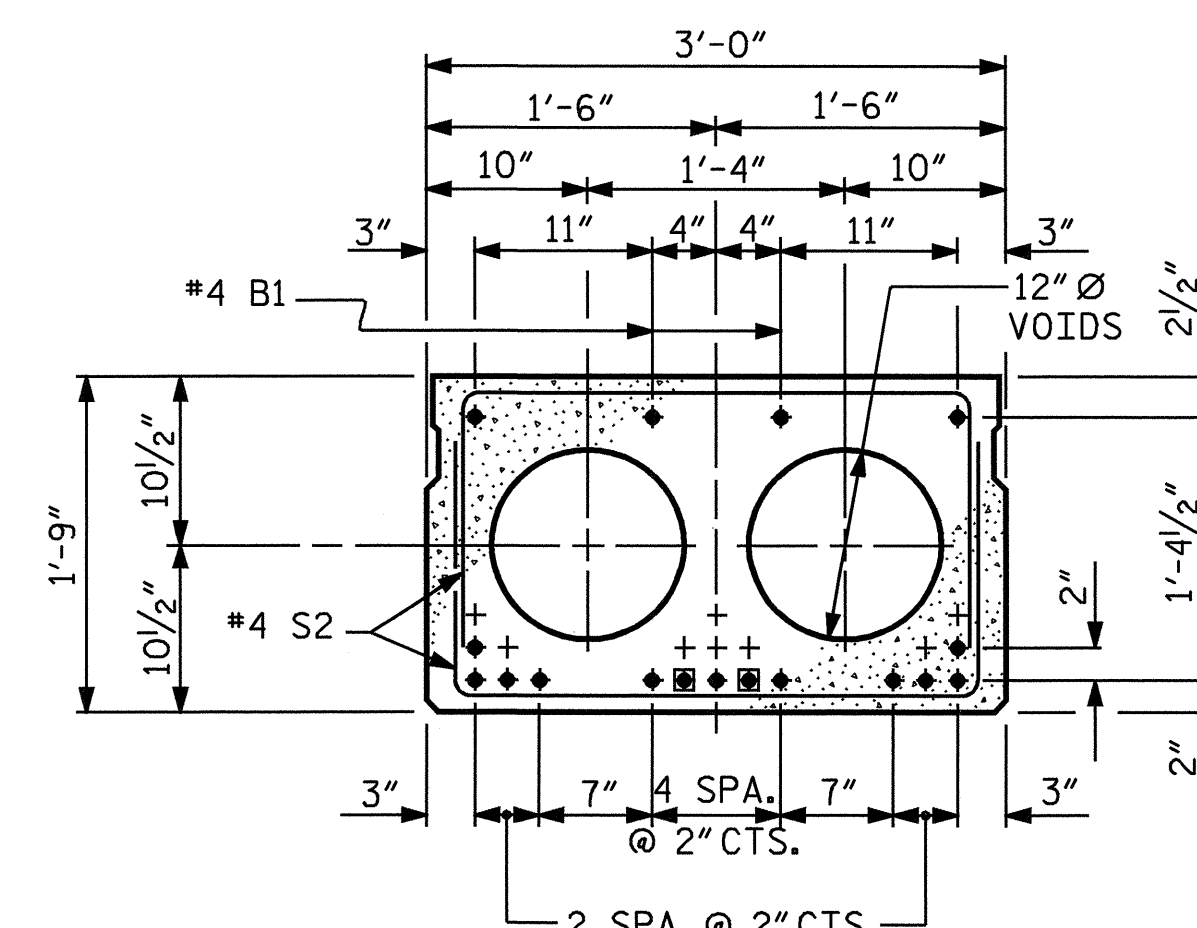

INTERIOR SLAB SECTION

1/2" Ø LOW RELAXATION
STRAND LAYOUT

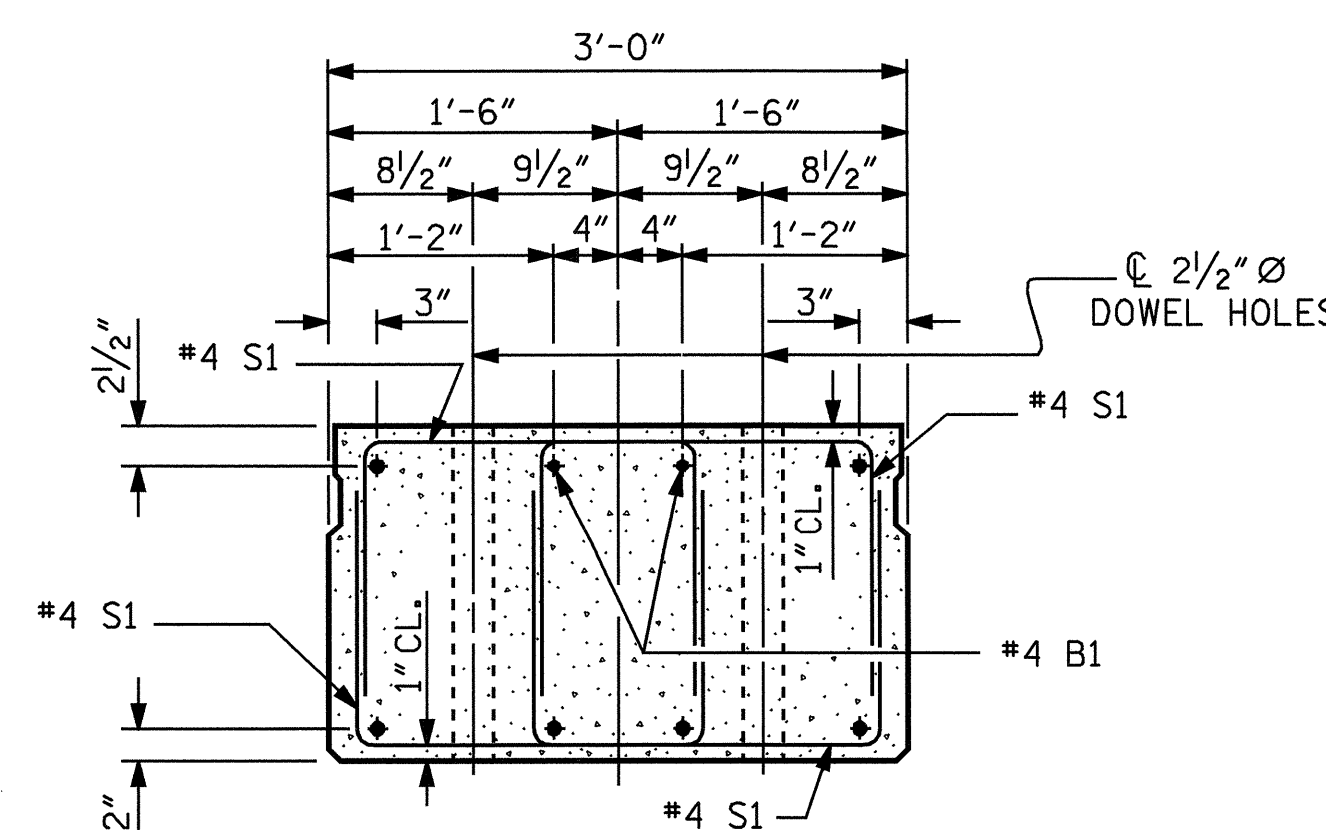

END ELEVATION

SHOWING PLACEMENT OF DOUBLE STIRRUPS AND
LOCATION OF DOWEL HOLES. (STRAND LAYOUT NOT SHOWN.)
INTERIOR SLAB SECTION SHOWN-EXTERIOR SLAB
SECTION SIMILAR EXCEPT SHEAR KEY LOCATION.

DRAWN BY : M. POOLE DATE : 6/04
CHECKED BY : J. LAMBERT DATE : 6/04

13-APR-2005 12:34
R:\STRUCT\B3663\mpoole\MICROSOFT\B3663.sd.ctb...
mpoole

PROJECT NO. B-3663
HENDERSON COUNTY
STATION: 12+96.30 -L-

SHEET 1 OF 3

STATE OF NORTH CAROLINA
DEPARTMENT OF TRANSPORTATION
RALEIGH

SUPERSTRUCTURE
3'-0" X 1'-9"
PRESTRESSED CONCRETE
CORED SLAB UNIT

REVISIONS						SHEET NO.	
NO.	BY:	DATE:	NO.	BY:	DATE:	S-4	TOTAL SHEETS
1			3				22
2			4				

