

5/28/99

STATE	PROJECT NO.	SHEET NO.	TOTAL SHEETS
N.C.	7CR.10411.11, ETC	7	14

7CR.10411.11, 7CR.20411.11,  
7CR.304106.11, 7CR.304126.11,  
7CR.304129.11, 7CR.304134.11

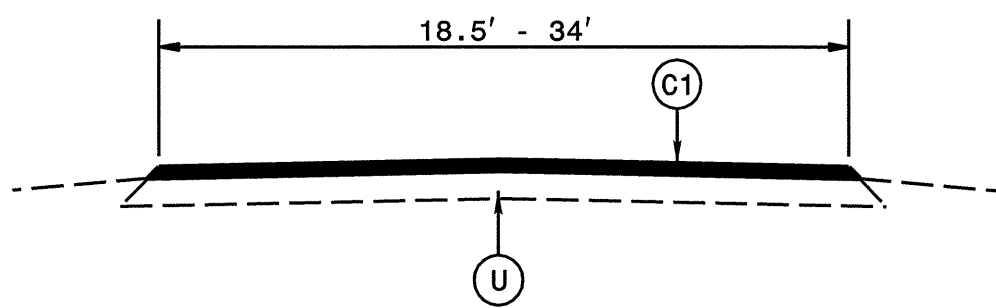

TYPICAL SECTION NO. 1

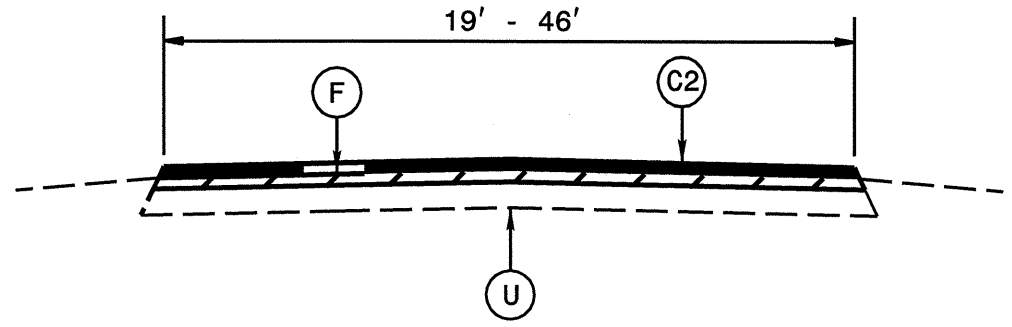

TYPICAL SECTION NO. 5

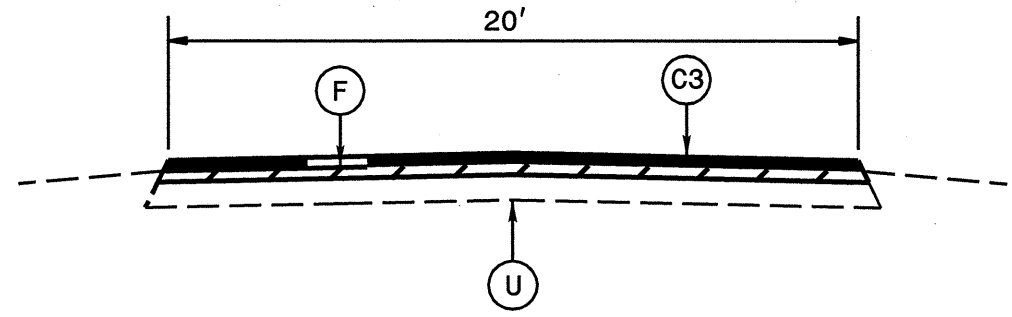

TYPICAL SECTION NO. 2

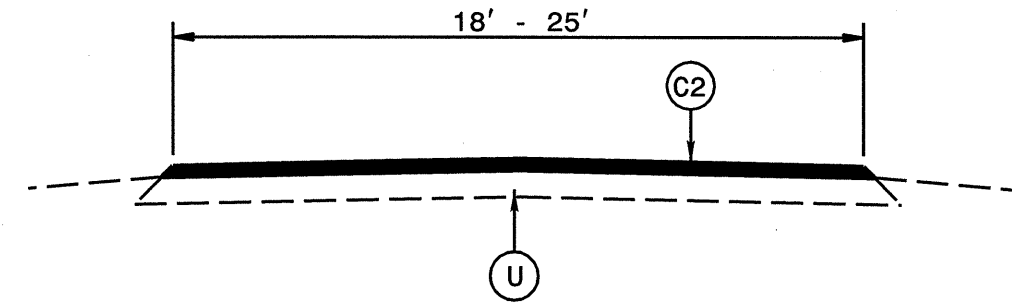

TYPICAL SECTION NO. 6

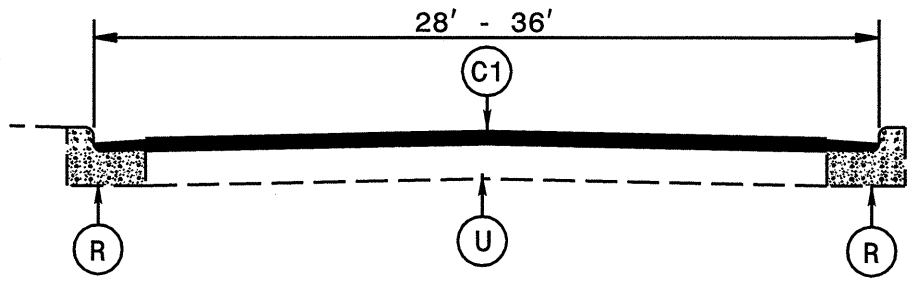

TYPICAL SECTION NO. 3

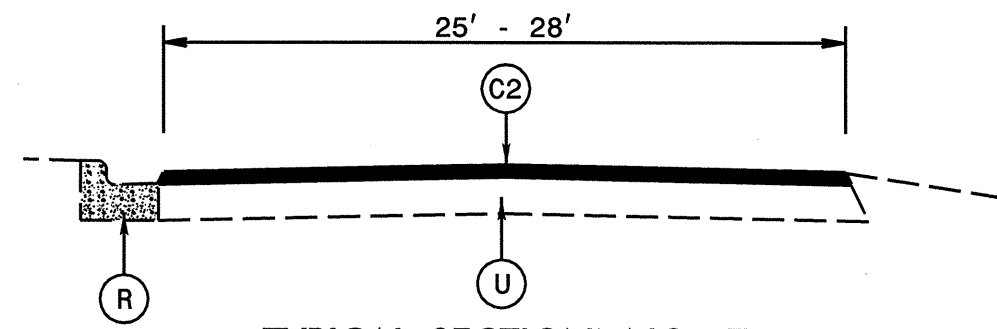

TYPICAL SECTION NO. 7

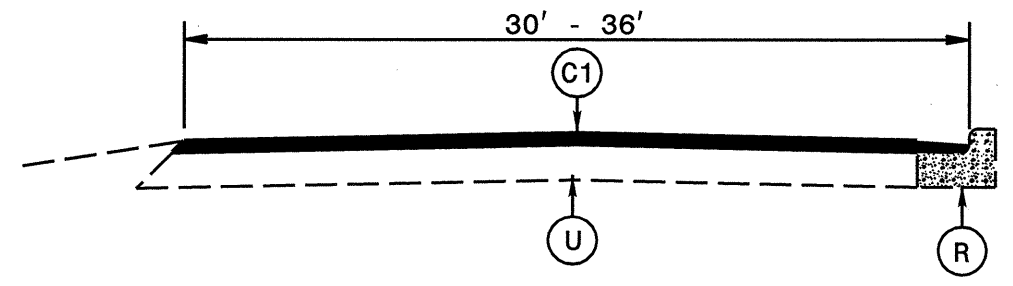

TYPICAL SECTION NO. 4

PAVEMENT SCHEDULE					
C1	PROP. APPROX. 1½" ASPHALT CONCRETE SURFACE COURSE, TYPE S9.5B, AT AN AVERAGE RATE OF 168 LBS. PER SQ. YD.	E	PROP. APPROX. 8" ASPHALT CONCRETE BASE COURSE, TYPE B25.0B, AT AN AVERAGE RATE OF 912 LBS. PER SQ. YD.		
C2	PROP. APPROX. 1" ASPHALT CONCRETE SURFACE COURSE, TYPE SF 9.5A, AT AN AVERAGE RATE OF 110 LBS. PER SQ. YD.	F	ASPHALT SURFACE TREATMENT, NO. 78M STONE		
C3	PROP. APPROX. 1¼" ASPHALT CONCRETE SURFACE COURSE, TYPE S9.5B, AT AN AVERAGE RATE OF 140 LBS. PER SQ. YD.	R	EXISTING CONCRETE ISLAND.		
D	PROP. APPROX. 3" ASPHALT INTERMEDIATE COURSE, TYPE I19.0B, AT AN AVERAGE RATE OF 342 LBS. PER SQ. YD.	U	EXISTING PAVEMENT.	T	EARTH MATERIAL.

\*\*\*\*\*SYTIME\*\*\*\*\*  
\*\*\*\*\*SECTION\*\*\*\*\*  
\*\*\*\*\*\*\*\*\*\*