

Project Special Provisions
Structure

Table of Contents

	Page
	#
Calcium Nitrite Corrosion Inhibitor (2-14-04)	1
Galvanizing Steel Piles (10-03-02)	2
Adhesively Anchored Anchor Bolts or Dowels (10-12-01)	2
Evazote Joint Seals (8-13-04)	5
Epoxy Protective Coating (10-12-01)	10
Elastomeric Concrete (10-12-01)	12
Falsework and Formwork (10-12-01)	13
Submittal of Working Drawings (6-7-05)	19
Elastomeric Bearings (10-03-02)	25
Prestressed Concrete Members (3-04-05)	25
Crane Safety (11-09-04)	26
Concrete Wearing Surface (3-04-05)	26
Prestressed Concrete Box Beam (3-04-05)	28



PROJECT SPECIAL PROVISIONS
STRUCTURE

PROJECT B-1303

NORTHAMPTON COUNTY

CALCIUM NITRITE CORROSION INHIBITOR

(2-14-04)

Add an approved calcium nitrite corrosion inhibitor (30% solids) to the concrete mix at the batch plant for the members identified by the plan notes. Clearly mark the prestressed concrete members that contain calcium nitrite.

Use the inhibitor at a minimum rate of 3.0 gal/yd³ (14.9 liters/m³). Ensure that the hardened concrete contains at least 5.1 lbs/yd³ (3.0 kg/m³) Nitrite (NO₂) when tested in accordance with N.C. Department of Transportation, Materials and Tests Method Chem. C-20.0 with the exception of concrete used in prestressed members. Test prestressed members as follows:

The Inspector will perform the complete C-21.0 "Field Test Procedure for the Nitrite Ion in Plastic Concrete" on plastic concrete samples obtained randomly from a truck used to pour concrete near each end (live end and dead end) of a prestressed concrete casting. Powder samples will be taken from hardened cylinders made at the time C-21.0 is run for any concrete that fails the C-21.0 (plastic test) method. The Chemical Testing Laboratory will test the powder using method C-20.0 "Determination of Nitrite in Hardened Concrete." Acceptance of the concrete is dependent in the results of method C-20.0 (hardened test) when any sample fails the C-21.0 (plastic test method).

The Inspector will perform a qualitative nitrite ion check by method C-22.0 (Field Spot Test) on each load of concrete batched for a prestressed concrete casting bed. Acceptance of the concrete is dependent on the results of method C-20.0 (hardened test) when any sample fails the C-22.0 (Field Spot Test). The producer may elect to not incorporate concrete that fails Method C-22.0 (Field Spot Test) in lieu of waiting for C-20.0 (hardened test) test results to determine the acceptability of the member. Once per each week's production of prestressed concrete with corrosion inhibitor, random samples of hardened concrete powder will be taken from cylinders used for method C-21.0 (plastic test). These samples will be submitted to the Chemical Testing Laboratory for analysis using method C-20.0 (hardened test).

Units with calcium nitrite in a quantity less than specified are subject to rejection.

Furnish concrete cylinders to the Engineer, in a quantity to be specified, to verify the concentrations of calcium nitrite in hardened concrete. Concrete failing to contain calcium nitrite at the required concentrations as tested is subject to rejection.

Use only air-entraining, water-reducing, and/or set-controlling admixtures in the production of concrete mixtures that are compatible with calcium nitrite solutions.

Strictly adhere to the manufacturer’s written recommendations regarding the use of admixtures including storage, transportation and method of mixing. If preferred, use calcium nitrite, which acts as an accelerator, in conjunction with a retarder to control the set of concrete, as per the manufacturer’s recommendation.

No separate payment will be made for furnishing and incorporating the calcium nitrite solution into the concrete mixture. The cost of furnishing and incorporating the admixture is considered a part of the work of fabricating and furnishing the prestressed concrete units or supplying Class AA concrete.

GALVANIZING STEEL PILES

(10-03-02)

1.0 DESCRIPTION

This work consists of surface preparation and galvanizing of steel piles in accordance with Section 1076 of the Standard Specifications. For steel piles, angles and plates, prepare the surface and provide materials in accordance with the applicable parts of the Standard Specifications.

2.0 BASIS OF PAYMENT

The work covered by this provision will be paid for at the contract lump sum price for “Galvanizing Steel Piles at Station 18+81.00 -L- In the case of an overrun in the quantity of “HP 12x53 Steel Piles”, the contract lump sum price for “Galvanizing Steel Piles at Station 18+81.00 -L-” will be prorated to each linear foot (meter) of the overrun quantity. This compensation includes the galvanizing of steel angles and plates when required. The above prices and payments will be full compensation for all work covered by this provision including but not limited to furnishing all materials, labor, tools, equipment and all incidentals necessary to complete the work.

Payment will be made under:

Galvanizing Steel Piles at Station 18+81.00 -L- Lump Sum

ADHESIVELY ANCHORED ANCHOR BOLTS OR DOWELS

(10-12-01)

1.0 DESCRIPTION

The work covered by this Special Provision consists of furnishing all necessary labor, equipment, and materials and performing all operations necessary for installing anchor bolts/dowels in concrete using an adhesive bonding system in accordance with the details shown on the plans and with the requirements of this specification unless otherwise directed.

Submit a description of the proposed adhesive bonding system to the Engineer for review, comments and acceptance. Include in the description the bolt type and its deformations, equipment, manufacturer's recommended hole diameter, embedment depth, material specifications, and any other material, equipment or procedure not covered by the plans or these specifications. List the properties of the adhesive, including density, minimum and maximum temperature application, setting time, shelf life, pot life, shear strength and compressive strength. If bars/dowels containing a corrosion protective coating are required, provide an adhesive that does not contain any chemical elements that are detrimental to the coating and include a statement to this effect in the submittal.

2.0 MATERIALS

Use an adhesive bonding system that has been tested for a tensile strength of 125% of the specified anchor bolt/dowel yield load. Provide certification that, for the particular bolt grade, diameter and embedment depth required, the anchor system will not fail by adhesive failure and that the anchor bolt/dowel will not move. The minimum concrete compressive strength is 3000 psi (20.7 MPa) for certification and anchorage selection.

Package components of the adhesive so that one whole container of each component mixes to form one batch of adhesive. Use containers designed so that all of the contents may be removed easily and sealed tightly to prevent leakage. Furnish adhesive material requiring hand mixing in two separate containers designated as Component A and Component B. Provide a self contained cartridge or capsule consisting of two components which are automatically mixed as they are dispensed, as in the case of a cartridge, or drilled into, as in the case of a capsule.

Clearly label each container with the manufacturer's name, date of manufacture, batch number, batch expiration date, direction for use, and warnings and precautions concerning the contents as required by State or Federal Laws and Regulations.

3.0 PROCEDURE

A. Drilling of Holes into Concrete

When directed, use a jig or fixture to ensure the holes are positioned and aligned correctly during the drilling process. Upon approval, adjusting hole locations to avoid reinforcing steel is permitted.

Drill the holes with a pneumatic drill unless another drilling method is approved. Follow the manufacturer's recommendations regarding the diameter of the drilled hole.

Immediately after completion of drilling, blow all dust and debris out of the holes with oil-free compressed air using a wand extending to the bottom of the hole. Remove all dust from the sides of the holes by brushing the holes with a stiff-bristled brush of a

sufficient size and then blow the hole free of dust. Repeat this procedure until the hole is completely clean. Check each hole with a depth gauge to ensure proper embedment depth.

Repair spalled or otherwise damaged concrete using approved methods.

B. Inspection of Holes

Inspect each hole immediately prior to placing the adhesive and the anchor bolts/dowels. Ensure all holes are dry and free of dust, dirt, oil, and grease. Rework any hole that does not meet the requirements of this Special Provision.

C. Mixing of Adhesive

Mix the adhesive in strict conformance with the manufacturer's instructions.

D. Embedment of Anchor Bolt/Dowel

Clean each anchor bolt/dowel so that it is free of all rust, grease, oil, and other contaminants.

Unless otherwise shown on the plans, the minimum anchor bolt/dowel embedment depth is such that the adhesive develops at least 125% of the anchor bolt/dowel yield load as determined by the manufacturer.

Insert the anchor bolt/dowel the specified depth into the hole and slightly agitate it to ensure wetting and complete encapsulation. After insertion of the anchor bolt/dowel, strike off any excessive adhesive flush with the concrete face. Should the adhesive fail to fill the hole, add additional adhesive to the hole to allow a flush strike-off.

Do not disturb the anchor bolts/dowels while adhesive is hardening.

4.0 FIELD TESTING

When specified on the plans, test the installed anchor bolts/dowels for adequate adhesive as specified below. Inform the Engineer when the tests will be performed at least 2 days prior to testing. Conduct the tests in the presence of the Engineer.

Use a calibrated hydraulic centerhole jack system for testing. Place the jack on a plate washer that has a hole at least 1/8 inch (3 mm) larger than the hole drilled into the concrete. Position the plate washer on center to allow an unobstructed pull. Position the anchor bolts/dowels and the jack on the same axis. Have an approved testing agency calibrate the jack within 6 months prior to testing. Supply the Engineer with a certificate of calibration.

In the presence of the Engineer, field test 10% of the first 50 anchor bolts/dowels prior to installing any additional anchors. For testing, apply and hold briefly 90% of the anchor bolt/dowel yield load shown on the plans. No visible signs of movement of the anchor bolts/dowels is permitted under this load. Upon receiving satisfactory results from these tests, install the remaining anchors. Test a minimum of 2% of the remaining anchors as previously described.

Record data for each anchor bolt/dowel tested on the report form entitled "Installation Test Report of Adhesively Anchored Anchor Bolts or Dowels". Obtain this form from the North Carolina Department of Transportation Materials and Tests Engineer. Submit a copy of the completed report forms to the Engineer.

Final acceptance of the adhesively anchored system is based on the conformance of the pull test to the requirements of this specification. Failure to meet the criteria of this specification is grounds for rejection.

5.0 BASIS OF PAYMENT

No separate measurement or payment will be made for furnishing, installing, and testing anchor bolts/dowels.

Payment at the contract unit prices for the various pay items will be full compensation for all materials, equipment, tools, labor, and incidentals necessary to complete the above work.

EVAZOTE JOINT SEALS

(8-13-04)

1.0 SEALS

Use preformed seals compatible with concrete and resistant to abrasion, oxidation, oils, gasoline, salt and other materials that are spilled on or applied to the surface. Use a low-density closed cell, cross-linked ethylene vinyl acetate polyethylene copolymer nitrogen blown material for the seal.

Use seals manufactured with grooves 1/8" (3 mm) ± wide by 1/8" (3 mm) ± deep and spaced between 1/4 (6 mm) and 1/2 inch (13 mm) apart along the bond surface running the length of the joint. Use seals sized so that the depth of the seal meets the manufacturer's recommendation, but is not less than 70% of the uncompressed width. Provide a seal designed so that, when compressed, the center portion of the top does not extend upward above the original height of the seal by more than 1/4 inch (6 mm). Splice the seal using the heat welding method by placing the joint material ends against a teflon heating iron of 350°F (177°C) for 7 - 10 seconds, then pressing the ends together tightly. Do not test the welding until the material has completely cooled. Use material that resists weathering and ultraviolet rays. Provide a seal that has a working range of 30% tension and 60% compression and is watertight along its entire length including the ends.

Provide seals that meet the requirements given below.

TEST	TEST METHOD	REQUIREMENT
Elongation at break	ASTM D3575	210 ± 15%
Tensile strength, psi (kPa)	ASTM D3575	110 ± 15 (755 ± 100)
Compression Recovery (% of original width)	AASHTO T42 50% compr. for 22 hr. @ 73°F (23°C) 1/2 hr. recovery	87 ± 3
Weather/Deterioration	AASHTO T42 Accelerated Weathering	No deterioration for 10 years min.
Compression/Deflection	@ 50% deflection of original width @ 50% deflection of original width	10 psi (69 kPa) min. 60 psi (414 kPa) max.
Tear Strength, psi (kPa)	ASTM D624	16 ± 3 (110 ± 20)
Density	ASTM D545	2.8 to 3.4
Water Absorption (% vol/vol)	ASTM D3575 Total immersion for 3 months	3

Have the top of the evazote seal clearly shop marked. Inspect the evazote seals upon receipt to ensure that the marks are clearly visible upon installation.

2.0 ADHESIVES

Use a two component, 100% solid, modified epoxy adhesive with the seal that meets the requirements of ASTM C881, Type 1, Grade 3, Class B & C and has the following physical properties:

- Tensile strength 3500 psi (24.1 MPa) min.
- Compressive strength 7000 psi (48.3 MPa) min.
- Shore D Hardness 75 psi (0.5 MPa) min.
- Water Absorption 0.25% by weight

Use an adhesive that is workable to 40°F (4°C). When installing in temperatures below 40°F (4°C) or for application on moist, difficult to dry concrete surfaces, use an adhesive specified by the manufacturer of the joint material.

3.0 SAWING THE JOINTS

When the plans call for sawing the joints, the joints shall be initially formed to a width as shown on the plans including the blockout for the elastomeric concrete. Complete placement of the elastomeric concrete after the reinforced concrete deck slab has cured for seven full days and reached a minimum strength of 3000 psi (20.7 Mpa).

Cure the elastomeric concrete for a minimum of 2 days prior to sawing the elastomeric concrete to the final width and depth as specified in the plans.

When sawing the joint to receive the evazote seal, always use a rigid guide to control the saw in the desired direction. To control the saw and to produce a straight line as indicated on the plans, anchor and positively connect a template or a track to the bridge deck. Do not saw the joint by visual means such as a chalk line. Fill the holes used for holding the template or track to the deck with an approved, flowable non-shrink, non-metallic grout.

Saw cut to the desired width and depth in one or two passes of the saw by placing and spacing two metal blades on the saw shaft to the desired width for compression seals.

The desired depth is the depth of the seal plus 1/4 inch (6 mm) above the top of the seal plus approximately 1 inch (25 mm) below the bottom of the seal. An irregular bottom of sawed joint is permitted as indicated on the plans. Grind exposed corners on saw cut edges to a 1/4" (6 mm) chamfer.

Remove any staining or deposited material resulting from sawing with a wet blade to the satisfaction of the Engineer.

Use extreme care to saw the joint straight to the desired width and to prevent any chipping or damage to sawed edges of the joint.

4.0 PREPARATIONS FOR SAWED JOINTS

When the plans call for sawing the joint, the Engineer thoroughly inspects the sawed joint opening for spalls, popouts, cracks, etc. Make all necessary repairs prior to blast cleaning and installing the seal.

Immediately before sealing, clean the joints by sandblasting with clean dry sand. Sandblast to provide a firm, clean joint surface free of curing compound, loose material and any foreign matter. Sandblast without causing pitting or uneven surfaces. The aggregate in the elastomeric concrete may be exposed after sandblasting.

After blasting, either brush the surface with clean brushes made of hair, bristle or fiber, blow the surface with compressed air, or vacuum the surface until all traces of blast products and abrasives are removed from the surface, pockets, and corners.

If nozzle blasting, use compressed air that does not contain detrimental amounts of water or oil.

Examine the blast cleaned surface and remove any traces of oil, grease or smudge deposited in the cleaning operations.

Bond the seal to the blast cleaned surface on the same day the surface is blast cleaned.

5.0 PREPARATIONS FOR ARMORED JOINTS

When the plans call for armored joints, form the joint and blockout openings in accordance with the plans. If preferred, wrap the temporary form with polyethylene sheets to allow for easier removal. Do not use form release agents.

A. Submittals

Submitting detailed working drawings is not required; however, submitting catalog cuts of the proposed material is required. In addition, direct the joint supplier to provide an angle segment placing plan.

B. Surface Preparation

Prepare the surface within the 48 hours prior to placing the elastomeric concrete. Do not place the elastomeric concrete until the surface preparation is completed and approved.

1. Angle Assembly

Clean and free metallized steel of all foreign contaminants and blast the non-metallized steel surfaces to SSPC SP-10. Blast-cleaning anchor studs is not required.

2. Concrete

Prior to placing the elastomeric concrete, thoroughly clean and dry all concrete surfaces. Sandblast the concrete surface in the blockout and clear the surface of all loose debris.

C. Elastomeric Concrete Placement

Make sure that a manufacturer's representative is present when placing elastomeric concrete. Do not place elastomeric concrete if the ambient air temperature is below 45°F (7°C).

Prepare and apply a primer, as per manufacturer's recommendations, to all vertical concrete faces, all steel components to be in contact with elastomeric concrete, and to areas specified by the manufacturer. Align the angles with the joint opening.

Prepare, batch, and place the elastomeric concrete in accordance with the manufacturer's instructions. Place the elastomeric concrete in the areas specified on the plans while the primer is still tacky and within 2 hours after applying the primer. Pay careful attention to properly consolidate the concrete around the steel and anchors. Trowel the elastomeric concrete to a smooth finish.

D. Joint Preparation

Prior to installing the seal, the Engineer thoroughly inspects the armored joint opening for proper alignment and full consolidation of elastomeric concrete under the angle assemblies. Make all necessary repairs prior to cleaning the joint opening and installing the seal.

Clean the armored joint opening with a pressure washer rated at 3000 psi (20.7 MPa) minimum at least 24 hours after placing the elastomeric concrete. Dry the cleaned surface prior to installing the seal.

Examine the cleaned surface and remove traces of oil, grease or smudge deposited during the cleaning operations.

Bond the seal to the cleaned surface on the same day the surface is cleaned.

6.0 SEAL INSTALLATION

Install the joint seal according to the manufacturer's procedures and recommendations and as recommended below. Do not install the joint seal if the ambient air temperature is below 45°F (7°C). Have a manufacturer's representative present during the installation of the first seal of the project.

Begin installation at the low end of the joint after applying the mixed epoxy to the sides of both the joint material and both sides of the joint, making certain to completely fill the grooves with epoxy. With gloved hands, compress the material and with the help of a blunt probe, push it down into the joint until it is recessed approximately 1/4 inch (6 mm) below the surface. Do not push the seal at an angle that would stretch the material. Once work on a joint begins, do not stop until it is completed. Clean the excess epoxy off the surface of the joint material *quickly* and *thoroughly*. Do not use solvents to remove excess epoxy. Remove excess epoxy in accordance with the joint manufacturer's recommendations.

Install the seal so that it is watertight. Testing of the joint seal is not required, but it is observed until final inspection.

7.0 BASIS OF PAYMENT

Payment for all evazote joint seals will be at the lump sum contract price bid for “Evazote Joint Seals” which prices and payment will be full compensation for furnishing all material, including elastomeric concrete when required, labor, tools and equipment necessary for installing these units in place and accepted.

EPOXY PROTECTIVE COATING

(10-12-01)

1.0 DESCRIPTION

This work consists of preparing the concrete surface and furnishing and applying an epoxy protective coating to the surfaces described in this Special Provision. When epoxy protective coating is required, cure the top surfaces of the bent or end bent caps in accordance with the Standard Specifications, but do not use the Membrane Curing Compound method.

2.0 MATERIALS

Use an epoxy coating that meets the most recently published NCDOT Specification on the date of advertisement. Use the epoxy coating that meets NCDOT-Type 4A Flexible, epoxy coating, moisture insensitive.

Provide a certification for the proposed epoxy showing that it meets NCDOT-Type 4A.

The following companies have epoxies that meet Type 4A Specifications:

- E-Bond Epoxy, Inc.
Fort Lauderdale, Florida 33307
- Permagine Industries
Plainview, NY 11803
- Poly-Carb
Cleveland, OH 44139
- Tamms, Inc.
Mentor, OH 44060
- Adhesive Engineering
Cleveland, OH 44122-5554
- Kaufman Products
Baltimore, MD 21226-1131

- Prime Resins
Lithonia, GA 30058
- Sika Corporation
Lyndhurst, N. J. 07071

A copy of the specifications for Epoxy Resin Systems is available from the Materials and Tests Unit.

3.0 SURFACES

With the exception of cored slab bridges, apply the epoxy protective coating to the top surface area, including chamfer area, of bent caps under expansion joints and of end bent caps, excluding areas under elastomeric bearings. For cored slab bridges, do not apply the epoxy protective coating to the bent or end bent caps. Also, apply epoxy protective coating to the ends of prestressed concrete members as noted on the plans.

Use extreme care to keep the area under the elastomeric bearings free of the epoxy protective coating. Do not apply the epoxy protective coating in the notch at the ends of the prestressed concrete girders.

Thoroughly clean all dust, dirt, grease, oil, laitance, and other objectionable material from the concrete surfaces to be coated. Air-blast all surfaces immediately prior to applying the protective coating.

Only use cleaning agents pre-approved by the Engineer.

4.0 APPLICATION

Apply epoxy protective coating only when the air temperature is at least 40°F (4°C) and rising, but less than 95°F (35°C) and the surface temperature of the area to be coated is at least 40°F (4°C). Remove any excess or free standing water from the surfaces before applying the coating. Apply one coat of epoxy protective coating at a rate such that it covers between 100 and 200 ft²/gal (2.5 and 5 m²/liter).

Note: Under certain combinations of circumstances, the cured epoxy protective coating may develop “oily” condition on the surface due to amine blush. This condition is not detrimental to the applied system.

Apply the coating so that the entire designated surface of the concrete is covered and all pores filled. To provide a uniform appearance, use the exact same material on all visible surfaces.

5.0 BASIS OF PAYMENT

No separate measurement or payment will be made for preparing, furnishing and applying the epoxy protective coating to the concrete surfaces.

Payment at the contract unit prices for the various pay items will be full compensation for the above work including all materials, equipment, tools, labor, and incidentals necessary to complete the work.

ELASTOMERIC CONCRETE

(10-12-01)

1.0 DESCRIPTION

Elastomeric concrete is a mixture of a two-part polymer consisting of polyurethane and/or epoxy, and kiln-dried aggregate. Have the manufacturer supply it as a unit. Use the concrete in the blocked out areas on both sides of the bridge deck joints as indicated on the plans.

2.0 MATERIALS

Provide materials that comply with the following minimum requirements at 14 days.

CONCRETE PROPERTIES	TEST METHOD	MINIMUM REQUIREMENT
Bond Strength to Concrete, psi (MPa)	ASTM D638 (D638M)	450 (3.1)
Brittleness by Impact, ft-lb (kg-m)	Ball Drop	7 (0.97)
Compressive Strength, psi (MPa)	ASTM D695 (D695M)	2800 (19.3)

BINDER PROPERTIES (without aggregate)	TEST METHOD	MINIMUM REQUIREMENT
Tensile Strength, psi (MPa)	ASTM D638 (D638M)	800 (5.5)
Ultimate Elongation	ASTM D638 (D638M)	150%
Tear Resistance, lb/in (kN/m)	ASTM D624	90 (15.7)

In addition to the requirements above, use elastomeric concrete that also resists water, chemical, UV, and ozone exposure and withstands extreme temperature (freeze-thaw) changes.

Furnish a manufacturer's certification verifying that the materials satisfy the above requirements. Provide samples of elastomeric concrete to the Engineer, if requested, to independently verify conformance with the above requirements.

Require a manufacturer's representative to be present on site during the installation of the elastomeric concrete.

3.0 BASIS OF PAYMENT

No separate payment will be made for elastomeric concrete. The lump sum contract price bid for "Evazote Joint Seals" will be full compensation for furnishing and placing the Elastomeric Concrete.

FALSEWORK AND FORMWORK

(10-12-01)

1.0 DESCRIPTION

Use this Special Provision as a guide to develop temporary works submittals required by the Standard Specifications or other provisions; no additional submittals are required herein. Such temporary works include, but are not limited to, falsework and formwork.

Falsework is any temporary construction used to support the permanent structure until it becomes self-supporting. Formwork is the temporary structure or mold used to retain plastic or fluid concrete in its designated shape until it hardens. Access scaffolding is a temporary structure that functions as a work platform that supports construction personnel, materials, and tools, but is not intended to support the structure. Scaffolding systems that are used to temporarily support permanent structures (as opposed to functioning as work platforms) are considered to be falsework under the definitions given. Shoring is a component of falsework such as horizontal, vertical, or inclined support members. Where the term "temporary works" is used, it includes all of the temporary facilities used in bridge construction that do not become part of the permanent structure.

Design and construct safe and adequate temporary works that will support all loads imposed and provide the necessary rigidity to achieve the lines and grades shown on the plans in the final structure.

2.0 MATERIALS

Select materials suitable for temporary works; however, select materials that also ensure the safety and quality required by the design assumptions. The Engineer has authority to reject material on the basis of its condition, inappropriate use, safety, or nonconformance with the plans. Clearly identify allowable loads or stresses for all materials or manufactured devices on the plans. Revise the plan and notify the Engineer if any change to materials or material strengths is required.

3.0 DESIGN REQUIREMENTS

A. Working Drawings

Provide working drawings for items as specified in the contract, or as required by the Engineer, with design calculations and supporting data in sufficient detail to permit a structural and safety review of the proposed design of the temporary work.

When concrete placement is involved, include data such as the drawings of proposed sequence, rate of placement, direction of placement, and location of all construction joints. Submit the number of copies as called for by the contract.

When required, have the drawings and calculations prepared under the guidance of, and sealed by, a North Carolina Registered Professional Engineer who is knowledgeable in temporary works design.

Design falsework and formwork requiring submittals in accordance with the 1995 AASHTO *Guide Design Specifications for Bridge Temporary Works* except as noted herein.

1. Wind Loads

Table 2.2 of Article 2.2.5.1 is modified to include wind velocities up to 110 mph (177 km/hr). In addition, Table 2.2A is included to provide the maximum wind speeds by county in North Carolina.

Table 2.2 - Wind Pressure Values

Height Zone feet (m) above ground	Pressure, lb/ft ² (kPa) for Indicated Wind Velocity, mph (km/hr)				
	70 (112.7)	80 (128.7)	90 (144.8)	100 (160.9)	110 (177.0)
0 to 30 (0 to 9.1)	15 (0.72)	20 (0.96)	25 (1.20)	30 (1.44)	35 (1.68)
30 to 50 (9.1 to 15.2)	20 (0.96)	25 (1.20)	30 (1.44)	35 (1.68)	40 (1.92)
50 to 100 (15.2 to 30.5)	25 (1.20)	30 (1.44)	35 (1.68)	40 (1.92)	45 (2.15)
over 100 (30.5)	30 (1.44)	35 (1.68)	40 (1.92)	45 (2.15)	50 (2.39)

2. Time of Removal

The following requirements replace those of Article 3.4.8.2.

Do not remove forms until the concrete has attained strengths required in Article 420-17 of the Standard Specifications and these Special Provisions.

Do not remove forms until the concrete has sufficient strength to prevent damage to the surface.

Table 2.2A - Steady State Maximum Wind Speeds by Counties in North Carolina

COUNTY	25 YR (mph) (km/hr)	COUNTY	25 YR (mph) (km/hr)	COUNTY	25 YR (mph) (km/hr)
Alamance	70 (112.7)	Franklin	70 (112.7)	Pamlico	100 (160.9)
Alexander	70 (112.7)	Gaston	70 (112.7)	Pasquotank	100 (160.9)
Alleghany	70 (112.7)	Gates	90 (144.8)	Pender	100 (160.9)
Anson	70 (112.7)	Graham	80 (128.7)	Perquimans	100 (160.9)
Ashe	70 (112.7)	Granville	70 (112.7)	Person	70 (112.7)
Avery	70 (112.7)	Greene	80 (128.7)	Pitt	90 (144.8)
Beaufort	100 (160.9)	Guilford	70 (112.7)	Polk	80 (128.7)
Bertie	90 (144.8)	Halifax	80 (128.7)	Randolph	70 (112.7)
Bladen	90 (144.8)	Harnett	70 (112.7)	Richmond	70 (112.7)
Brunswick	100 (160.9)	Haywood	80 (128.7)	Robeson	80 (128.7)
Buncombe	80 (128.7)	Henderson	80 (128.7)	Rockingham	70 (112.7)
Burke	70 (112.7)	Hertford	90 (144.8)	Rowan	70 (112.7)
Cabarrus	70 (112.7)	Hoke	70 (112.7)	Rutherford	70 (112.7)
Caldwell	70 (112.7)	Hyde	110 (177.0)	Sampson	90 (144.8)
Camden	100 (160.9)	Iredell	70 (112.7)	Scotland	70 (112.7)
Carteret	110 (177.0)	Jackson	80 (128.7)	Stanley	70 (112.7)
Caswell	70 (112.7)	Johnston	80 (128.7)	Stokes	70 (112.7)
Catawba	70 (112.7)	Jones	100 (160.9)	Surry	70 (112.7)
Cherokee	80 (128.7)	Lee	70 (112.7)	Swain	80 (128.7)
Chatham	70 (112.7)	Lenoir	90 (144.8)	Transylvania	80 (128.7)
Chowan	90 (144.8)	Lincoln	70 (112.7)	Tyrell	100 (160.9)
Clay	80 (128.7)	Macon	80 (128.7)	Union	70 (112.7)
Cleveland	70 (112.7)	Madison	80 (128.7)	Vance	70 (112.7)
Columbus	90 (144.8)	Martin	90 (144.8)	Wake	70 (112.7)
Craven	100 (160.9)	McDowell	70 (112.7)	Warren	70 (112.7)
Cumberland	80 (128.7)	Mecklenburg	70 (112.7)	Washington	100 (160.9)
Currituck	100 (160.9)	Mitchell	70 (112.7)	Watauga	70 (112.7)
Dare	110 (177.0)	Montgomery	70(112.7)	Wayne	80 (128.7)
Davidson	70 (112.7)	Moore	70 (112.7)	Wilkes	70 (112.7)
Davie	70 (112.7)	Nash	80 (128.7)	Wilson	80 (128.7)
Duplin	90 (144.8)	New Hanover	100 (160.9)	Yadkin	70 (112.7)
Durham	70 (112.7)	Northampton	80 (128.7)	Yancey	70 (112.7)
Edgecombe	80 (128.7)	Onslow	100 (160.9)		
Forsyth	70 (112.7)	Orange	70 (112.7)		

Note on the working drawings any anchorages, connectors, inserts, steel sleeves or other such devices used as part of the falsework or formwork that remains in the permanent structure. If the plan notes indicate that the structure contains the necessary corrosion protection required for a Corrosive Site, epoxy coat, galvanize, metallize or otherwise protect these devices as directed by the Engineer. Any coating required by the Engineer will be considered incidental to the various pay items requiring temporary works.

B. Review and Approval

The Engineer is responsible for the review and approval of temporary works' drawings.

Submit the working drawings sufficiently in advance of proposed use to allow for their review, revision (if needed), and approval without delay to the work.

Do not start construction of any temporary work for which working drawings are required until the drawings have been approved. Such approval does not relieve the Contractor of the responsibility for the accuracy and adequacy of the working drawings.

The time period for review of the working drawings does not begin until complete drawings and design calculations, when required, are received by the Engineer.

On the drawings, show all information necessary to allow the design of any component to be checked independently as determined by the Engineer.

If requested by the Engineer, submit with the working drawings manufacturer's catalog data listing the weight of all construction equipment that will be supported on the temporary work. Show anticipated total settlements and/or deflections of falsework and forms on the working drawings. Include falsework footing settlements, joint take-up, and deflection of beams or girders. Design the falsework and forms supporting deck slabs and overhangs on girder bridges so that there will be no differential settlement between the girders and the deck forms during placement of deck concrete.

4.0 CONSTRUCTION REQUIREMENTS

All requirements of Section 420 of the Standard Specifications apply.

Construct temporary works in conformance with the approved working drawings. Ensure that the quality of materials and workmanship employed is consistent with that assumed in the design of the temporary works. Do not weld falsework members to any portion of the permanent structure unless approved. Show any welding to the permanent structure on the approved construction drawings.

Provide tell-tales attached to the forms and extending to the ground, or other means, for accurate measurement of falsework settlement. Make sure that the anticipated compressive settlement and/or deflection of falsework does not exceed 1 inch (25 mm). For cast-in-place concrete structures, make sure that the calculated deflection of falsework

flexural members does not exceed $1/240$ of their span regardless of whether or not the deflection is compensated by camber strips.

A. Maintenance and Inspection

Inspect and maintain the temporary work in an acceptable condition throughout the period of its use. Certify that the manufactured devices have been maintained in a condition to allow them to safely carry their rated loads. Clearly mark each piece so that its capacity can be readily determined at the job site.

Perform an in-depth inspection of an applicable portion(s) of the temporary works, in the presence of the Engineer, not more than 24 hours prior to the beginning of each concrete placement. Inspect other temporary works at least once a month to ensure that they are functioning properly. Have a North Carolina Registered Professional Engineer inspect the cofferdams, shoring, sheathing, support of excavation structures, and support systems for load tests prior to loading.

B. Foundations

Determine the safe bearing capacity of the foundation material on which the supports for temporary works rest. If required by the Engineer, conduct load tests to verify proposed bearing capacity values that are marginal or in other high-risk situations.

The use of the foundation support values shown on the contract plans of the permanent structure is permitted if the foundations are on the same level and on the same soil as those of the permanent structure.

Allow for adequate site drainage or soil protection to prevent soil saturation and washout of the soil supporting the temporary works supports.

If piles are used, the estimation of capacities and later confirmation during construction using standard procedures based on the driving characteristics of the pile is permitted. If preferred, use load tests to confirm the estimated capacities; or, if required by the Engineer conduct load tests to verify bearing capacity values that are marginal or in other high risk situations.

The Engineer reviews and approves the proposed pile and soil bearing capacities.

5.0 REMOVAL

Unless otherwise permitted, remove and keep all temporary works upon completion of the work. Do not disturb or otherwise damage the finished work.

Remove temporary works in conformance with the contract documents. Remove them in such a manner as to permit the structure to uniformly and gradually take the stresses due to its own weight.

6.0 METHOD OF MEASUREMENT

Unless otherwise specified, temporary works will not be directly measured.

7.0 BASIS OF PAYMENT

Payment at the contract unit prices for the various pay items requiring temporary works will be full compensation for the above falsework and formwork.

SUBMITTAL OF WORKING DRAWINGS**(6-7-05)****1.0 GENERAL**

Submit working drawings in accordance with Article 105-2 of the Standard Specifications and the requirements of this Special Provision. The list of submittals contained herein does not represent a list of required submittals for this project. Submittals are only necessary for those items as required by the Standard Specifications, other Special Provisions, or contract plans. Make submittals that are not specifically noted in this Special Provision directly to the Resident Engineer.

If submittals contain variations from plan details or specifications, significantly affect project cost, or significantly affect field construction or operations, discuss them with, and submit them through, the Resident Engineer. State the reason for the proposed variation in the submittals. To minimize overall review time, make sure all working drawing submittals are complete when first submitted. Provide a contact name and phone number with each submittal. Direct any questions regarding working drawing submittal requirements to the Resident Engineer, Structure Design Unit contacts or the Geotechnical Engineering Unit contacts noted below.

2.0 WORKING DRAWINGS SUBMITTAL CONTACTS

All submittals noted herein are reviewed by the Structure Design Unit and/or the Geotechnical Engineering Unit.

For submittals to the Structure Design Unit, use the following addresses:

Via US mail:

Mr. G. R. Perfetti, P. E.
State Bridge Design Engineer
North Carolina Department
of Transportation
Structure Design Unit
1581 Mail Service Center
Raleigh, NC 27699-1581

Attention: Mr. P. D. Lambert, P. E.

Via other delivery service:

Mr. G. R. Perfetti, P. E.
State Bridge Design Engineer
North Carolina Department
of Transportation
Structure Design Unit
1000 Birch Ridge Drive
Raleigh, NC 27610

Attention: Mr. P. D. Lambert, P. E.

For submittals to the Geotechnical Engineering Unit, use the following addresses:

For projects in Divisions 1-7, use the following Eastern Regional Office address:

Via US mail:

Mr. K. J. Kim, Ph. D., P. E.
Eastern Regional Geotechnical
Manager
North Carolina Department
of Transportation
Geotechnical Engineering Unit
Eastern Regional Office
1570 Mail Service Center
Raleigh, NC 27699-1570

Via other delivery service:

Mr. K. J. Kim, Ph. D., P. E.
Eastern Regional Geotechnical
Manager
North Carolina Department
of Transportation
Geotechnical Engineering Unit
Eastern Regional Office
3301 Jones Sausage Road, Suite 100
Garner, NC 27529

For projects in Divisions 8-14, use the following Western Regional Office address:

Via US mail:

Mr. John Pilipchuk, L. G., P. E.
Western Regional Geotechnical
Manager
North Carolina Department
of Transportation
Geotechnical Engineering Unit
Western Regional Office
5253 Z Max Boulevard
Harrisburg, NC 28075

Via other delivery service:

Mr. John Pilipchuk, L. G., P. E.
Western Region Geotechnical
Manager
North Carolina Department
of Transportation
Geotechnical Engineering Unit
Western Regional Office
5253 Z Max Boulevard
Harrisburg, NC 28075

Direct any questions concerning submittal review status, review comments, or drawing markups to the following contacts:

Primary Structures Contact:

Paul Lambert
(919) 250 – 4041
(919) 250 – 4082 facsimile
plambert@dot.state.nc.us

Secondary Structures Contacts:

James Gaither (919) 250 – 4042
Man-Pan Hui (919) 250 – 4044

Eastern Regional Geotechnical Contact (Divisions 1-7):

K. J. Kim
(919) 662 – 4710
(919) 662 – 3095 facsimile
kkim@dot.state.nc.us

Western Regional Geotechnical Contact (Divisions 8-14):

John Pilipchuk
(704) 455 – 8902
(704) 455 – 8912 facsimile
jpilipchuk@dot.state.nc.us

3.0 SUBMITTAL COPIES

The quantities provided in this Special Provision act as a guide in the submittal process.

Unless otherwise required by the contract, submit two sets of supporting calculations to the Structure Design Unit.

Furnish one complete copy of the submittal, including all attachments, to the Resident Engineer. If requested, provide additional copies of any submittal. At the same time, submit the following number of copies directly to the Structure Design Unit and/or the Geotechnical Engineering Unit:

Working Drawing Submittal	Copies Required by Structure Design Unit	Copies Required by Geotechnical Engineering Unit	Contract Reference Requiring Submittal ¹
Arch Culvert Falsework	5	0	Plan Note & SN Sheet
Box Culvert Falsework ²	5	0	Plan Note & SN Sheet
Cofferdams ⁴	6	1	Articles 410-5 and 420-8
Expansion Joint Seals (hold down plate type with base angle)	9	0	“Expansion Joint Seals”
Expansion Joint Seals (modular)	2, then 9	0	“Modular Expansion Joint Seals”
Expansion Joint Seals (strip seals)	9	0	“Strip Seals”
Falsework & Forms (superstructure)	8	0	Article 420-3
Falsework & Forms ² (substructure)	8	0	Article 420-3
Mechanically Stabilized Earth Retaining Walls ⁴	7	1	“MSE Retaining Walls”
Metal Bridge Railing	8	0	Plan Note
Metal Stay-in-Place Forms	8	0	Article 420-3
Metalwork for Elastomeric Bearings ^{5,6}	7	0	Article 1072-10
Miscellaneous Metalwork ^{5,6}	7	0	Article 1072-10
Overhead Sign Assemblies	13	0	Article 903-3(C)
Pile Points	7	1	Article 450-8(D) & “Steel Pile Points”
Placement of Equipment on Structures (cranes, etc.)	7	0	Article 420-20

Precast Concrete Box Culverts	2, then 1 reproducible	0	“(Optional) Precast Reinforced Concrete Box Culvert at Station ____”
Precast Retaining Wall Panels	10	0	Article 1077-2
Pot bearings ⁵	8	0	“Pot Bearings”
Prestressed Concrete Deck Panels	6 and 1 reproducible	0	Article 420-3
Proprietary retaining walls ⁴	9	0	Applicable Project Special Provision
Prestressed Concrete Girder (strand elongation and detensioning sequences)	6	0	Articles 1078-8 and 1078-11
Prestressed Concrete Cored Slab (detensioning sequences) ³	6	0	Article 1078-11
Revised Bridge Deck Plans (adaptation to metal stay-in-place forms)	2, then 1 reproducible	0	Article 420-3
Revised Bridge Deck Plans (adaptation to modular expansion joint seals)	2, then 1 reproducible	0	“Modular Expansion Joint Seals”
Soil Nail Retaining Walls ⁴	4	1	Applicable Project Special Provision
Sound Barrier Wall Steel Fabrication Plans ⁶	7	0	Article 1072-10 & “Sound Barrier Wall”
Sound Barrier Wall Casting Plans	10	0	Article 1077-2 & “Sound Barrier Wall”
Structural Steel ⁵	2, then 7	0	Article 1072-10
TFE Expansion Bearings ⁵	8	0	Article 1072-10
Temporary Detour Structures ⁴	10	1	Article 400-3 & “Construction, Maintenance and Removal of Temporary Structure at Station ____”
Temporary Shoring ⁴	6	1	Article 410-4 & “Temporary Shoring for Maintenance of Traffic”

Temporary Fabric or Wire Walls ⁸	0	2	Applicable Project Special Provision
Permanent Anchored Tieback Retaining Walls ⁴	4	1	Applicable Project Special Provision
Evazote Joint Seals ⁷	9	0	Applicable Project Special Provision
Optional Disc Bearings ⁵	8	0	“Optional Disc Bearings”
Removal of Existing Structure over Railroad	5	0	Railroad Special Provisions
Drilled Pier Construction Sequence Plans ⁸	0	1	“Drilled Piers”
Pile Hammers ⁸	0	1	Article 450-6
Crosshole Sonic Logging (CSL) Reports ⁸	0	1	“Crosshole Sonic Logging”
Pile Driving Analyzer (PDA) Reports ⁸	0	1	“Pile Driving Analyzer”

FOOTNOTES

- References are provided to help locate the part of the contract where the working drawing submittals are required. References in quotes refer to the Project Special Provision by that name. Articles refer to the Standard Specifications.
- Submittals for these items are necessary only when plan notes require them.
- Submittals for these items may not be required. A list of pre-approved sequences is available from the producer or the Materials and Tests Unit.
- These submittals are reviewed by the Structure Design Unit and the Geotechnical Engineering Unit. If NCDOT Shoring Standards are used, working drawings need not be submitted, but the Shoring Selection Form should be forwarded to the Geotechnical Engineering Unit.
- The fabricator may submit these items directly to the Structure Design Unit.
- The two sets of preliminary submittals required by Article 1072-10 of the Standard Specifications are not required for these items.
- Submittals for Fabrication Drawings are not required. Submission of Catalogue Cuts of Proposed Material is required. See Section 5.A of the Project Special Provision.
- Submittals for these items are reviewed by the Geotechnical Engineering Unit only and correspondence regarding these items should be directed to and will come from the Geotechnical Engineering Unit.

ELASTOMERIC BEARINGS

(10-03-02)

Use elastomeric bearings in accordance with Article 1079-2 of the Standard Specifications except as follows:

**TABLE 1079-2
NATURAL RUBBER ELASTOMER REQUIREMENTS**

Grade (durometer)	50	60
PHYSICAL PROPERTIES Hardness ASTM D2240	50 +5 -5	60 +5 -5

PRESTRESSED CONCRETE MEMBERS

3-04-05

In Section 1078-12 of the Standard Specifications. After the first sentence of “5,” place the following:

“Conduit may be rigid one-piece or rigid two-piece (split sheathed). Do not use flexible conduit.”

In Section 1078-13 of the Standard Specifications, after the fourth paragraph add the following paragraph:

“When handling the prestressed concrete members, a temporary stress of $5\sqrt{f_{ci}}$ is permitted, where f_{ci} is the strength of concrete at release, in psi.”

In Section 1078-5 of the Standard Specifications, place the following two sentences after the first paragraph:

“When casting holes through the top flange of Bulb Tee Girders for overhang or interior bay falsework hanger rods use rigid PVC conduits with a wall thickness of approximately 1/8 inch. Do not use thin wall material. Secure conduits in the forms so that they do not migrate out of the proper location. Other methods of forming holes may be proposed but are subject to the Engineer’s approval.”

“When casting dowel rod holes in cored slab or box beam members use material that creates round, vertical holes of the specified diameter and in the correct location. Do not use material that deforms, collapses or shifts position during casting of the member.”

CRANE SAFETY

(11-09-04)

Submit all items listed below to the Engineer prior to beginning crane operations. . Changes in personnel or equipment must be reported to the Engineer and all applicable items listed below must be updated and submitted prior to continuing with crane operations.

Comply with the manufacturer specifications and limitations applicable to the operation of any and all cranes and derricks. Prime contractors, sub-contractors, and fully operated rental companies shall comply with the current Occupational Safety and Health Administration regulations (OSHA).

CRANE SAFETY SUBMITTAL LIST

- A. **Competent Person:** Provide the name and qualifications of the “Competent Person” responsible for crane safety and lifting operations. The named competent person will have the responsibility and authority to stop any work activity due to safety concerns.
- B. **Riggers:** Provide the qualifications, experience and training of the persons responsible for rigging operations. Training should include, but not be limited to, weight calculations, center of gravity determinations, sling selection and capacities, sling and rigging equipment inspection, safe rigging practices, and determining load weights.
- C. **Crane Inspections:** Inspection records for all cranes shall be current and readily accessible for review upon request.
- D. **Crane Operators:** By January 1, 2006, all crane operators shall be certified by NC CCO (National Commission for the Certification of Crane Operators), or satisfactorily complete the Carolinas AGC’s Professional Crane Operator's Proficiency Program. Other approved nationally accredited programs will be considered upon request. Submit current certification for the type of crane operated (small hydraulic, large hydraulic, small lattice, large lattice) and medical evaluations, for each operator.

Medical evaluations shall meet or exceed the CCO medical evaluation requirements and must remain current within a 3-year expiration date. Utilize either the CCO Physical Examination Form or a current DOT Medical Examiner’s Certificate.

CONCRETE WEARING SURFACE

03-04-05

1.0 GENERAL

This Special Provision governs materials, forming, and all other related work in the construction of a reinforced concrete wearing surface in accordance with applicable parts of the Standard Specifications, the details shown on the plans, and as outlined in these Special Provisions.

2.0 MATERIALS

Unless otherwise noted on the plans, use class AA concrete and a coarse aggregate gradation of 78M. The Class AA concrete shall contain fly ash or ground granulated blast furnace slag at the substitution rate specified in Article 1024-1 and in accordance with Articles 1024-5 and 1024-6 of the Standard Specifications, and shall contain calcium nitrite corrosion inhibitor. Place the wearing surface according to the grades, thicknesses and cross sections shown on the plans.

3.0 PREPARATION OF SURFACE

Completely clean all surfaces within the 48 hours prior to placing the overlay unless otherwise approved.

Thoroughly soak the cleaned surface for at least 12 hours prior to placing the concrete wearing surface. While soaking the surface, cover it with a layer of white opaque polyethylene film that is at least 4 mils (0.100 mm) thick. Immediately prior to placing the concrete wearing surface, remove standing water from the surface.

4.0 EQUIPMENT

Prior to beginning any work, obtain approval for all equipment to be used for deck preparation, placing, finishing, and curing the concrete wearing surface.

For surface preparation, use sandblasting or pressure washing equipment capable of removing all foreign matter. If using high pressure water blast, a minimum nozzle pressure of 3000 psi is required.

5.0 PLACING AND FINISHING

Follow the placing, finishing, and curing requirements of Article 420-15 (A) and (B). Construction Joints other than those shown on the plans are not permitted.

6.0 LIMITATIONS OF OPERATIONS

Vehicles and construction equipment are not permitted on the finished concrete wearing surface until the seven day curing time is completed and the concrete reaches the minimum specified compressive strength.

Use insulation that meets the requirements of Article 420-9(c), and if required, place it on the concrete wearing surface as soon as the initial set permits.

7.0 METHOD OF MEASUREMENT

The quantity of concrete wearing surface to be paid for is the actual number of square feet (square meters) of concrete wearing surface as provided on the plans.

8.0 BASIS OF PAYMENT

The quantity for which payment is made will be that quantity shown in square feet (square meters) on the plans. Where the plans have been revised, the quantity to be paid for will be the quantity shown on the revised plans.

The unit bid per square foot (square meter) will be full compensation for all work covered by this Special Provision and applicable parts of the Standard Specifications, but not limited to furnishing and placing concrete, joint filler and sealer, deck drains, bridge scuppers, and any other material; erecting and removing all forms, curing concrete, protecting concrete in wind, rain, low humidity, high temperatures or other unfavorable weather.

Payment will be made under:

Concrete Wearing Surface Square Foot (Square Meter)

PRESTRESSED CONCRETE BOX BEAM

03-04-05

The prestressed box beam members shall meet the requirements for prestressed concrete members as specified in the Standard Specifications with the following exceptions and additions.

1.0 FABRICATION

Place concrete for box beams in 2 or more horizontal layers. Place and compact each layer before the preceding layer takes initial set so that there is no surface or separation between layers. Should shrinkage or settlement cracks occur, the Engineer reserves the right to require additional layers and/or vibration.

The requirements of the above paragraph may be waived if use of self-consolidating concrete is approved by the Engineer.

When box beams are cast, a positive hold-down system shall be employed to prevent voids from moving. Design the system to be left in place until the concrete has reached the release strength. At least six weeks prior to casting box beams, the Contractor shall submit to the Engineer for review and comment, detailed drawings of the proposed void material and hold-down system. In addition to structural details, location and spacing of the hold-downs shall be indicated. The Contractor shall also submit his proposed method of concrete placement and of consolidating the concrete under the void.

Rake the top surface of the box beam section to a depth of 3/8" (10 mm). No surface finish is required for sides and bottom of the box beam sections except the exposed side of the exterior beam section as noted below. Provide a resulting surface finish essentially the same color and surface finish as the surrounding concrete. Fill all voids in the outside face of exterior box beams with a sand-cement or other approved grout. Repair voids greater than 1/4" (6 mm) in diameter or depth in other faces of the box beams in a like manner. Where an excessive number of smaller voids exist in any member, the Engineer requires a similar repair.

Provide a $\frac{3}{4}$ " (19 mm) chamfer along the bottom edges on ends and sides of all beam sections, top outside edges of exterior beam sections and acute corners of beam sections. Round the top edges on ends of all sections with a $\frac{1}{4}$ " (6 mm) finishing tool. Provide square corners along top edges on all slab sections along shear keys. Do not chamfer vertical edges at ends of beam sections.

2.0 ALIGNMENT AND DIRECTIONAL TOLERANCES

In order to ensure a good, neat field fit, assemble box beam spans in the yard and have pieces match-marked. Ensure that pieces fit together neatly and in a workman-like manner. Manufacture the box beams within the tolerances listed in the "Box Beam Tolerances" table and sketches.

3.0 ERECTION

The post tensioning system shall use 0.6" (15mm) diameter strands or $\frac{1}{4}$ " (32mm) diameter steel bars. Steel bars shall have a minimum yield strength of 150,000 psi (1034.2 MPa), meeting the requirements of ASTM A722. Strands shall be tensioned to 43,950 pounds (195.5 kN) and bars shall be tensioned to 150,000 pounds (667 kN). Strands shall be placed in a non-corrosive 0.6" (15mm) diameter, $\frac{1}{16}$ " (1.6mm) minimum wall thickness black polyethylene pipe meeting the requirements of ASTM D2239. Similarly, bars shall be placed in a black polyethylene pipe.

When erecting prestressed box beams, place the transverse post tensioning system in the diaphragms, place grout in the grout pockets located at the areas of the post tensioning strands, if provided, and tension to the required force. Grease the bars or strands and place in the polyethylene pipe. Do not apply grease or extend the pipe in the area of the recesses at the ends of the tensioning strands where grout is applied. Tension the bars or strands in the diaphragm nearest mid-span first. Proceed to tension bars or strands in the adjacent diaphragms. Continue the tensioning operation in a symmetric manner along the length of the span. At each diaphragm location, maintain a symmetric tension force between each pair of bars or strands in the diaphragm. After all tensioning in a span is completed and before placing any equipment, material or barrier rail on the span, fill the shear key, dowel holes, and recesses at the ends of the diaphragm with an approved non-metallic, non-shrink grout. Cure for 3 days minimum and until the grout reaches a compressive strength of 3000 psi (20.7 MPa).

After tensioning and curing, obtain approval prior to placing material and equipment on the box beam spans. Support cranes or other equipment exceeding the legal load limit on mats. Submit for review a detailed drawing for the mats that are intended for use on the box beams. Provide a complete description of the equipment that is intended for placement on the mats. Supply and construct mats at no additional cost to the Department.

4.0 PAYMENT

The quantity of prestressed concrete box beams shown on the plans will be paid for at the contract unit price per linear foot for "3'0" x 2'-3" Prestressed Concrete Box Beams." This price and payment shall be full compensation for furnishing and placing the prestressed concrete box beams and includes all materials, tools, equipment, labor and incidentals necessary to complete this work.

BOX BEAM TOLERANCES:

a = Length: ± 1 in.

b = Width (overall): $\pm \frac{1}{4}$ in.

c = Depth (overall): $\pm \frac{1}{4}$ in.

d = Variation from specified plan end squareness or skew:

$\pm \frac{1}{8}$ in. per 12 in. width, $\pm \frac{1}{2}$ in. max.

e = Variation from specified elevation end squareness or skew:

$\pm \frac{1}{8}$ in. per 12 in., $\pm \frac{1}{2}$ in. max.

f = Sweep, for member length:

up to 40 ft. $\pm \frac{1}{4}$ in.

40 to 60 ft. $\pm \frac{3}{8}$ in.

greater than 60 ft. $\pm \frac{1}{2}$ in.

g = Differential camber between adjacent members:

$\frac{1}{4}$ in. per 10 ft., $\frac{3}{4}$ in. max.

h = Local smoothness of any surface: $\frac{1}{4}$ in. in 10 ft.

k = Position of strands: $\pm \frac{1}{4}$ in.

n = Longitudinal Position of blockout: ± 1 in.

o_1 = Position of dowel holes: $\pm \frac{1}{4}$ "

o_2 = Position of sleeves cast in beams, in both horizontal and vertical plane: $\pm \frac{1}{2}$ in.

p = Position of void: $\pm \frac{3}{8}$ "

Bearing area – deviation from plane surface: $\pm \frac{1}{16}$ "

Width of any one span = Plan width + $\frac{1}{8}$ " per joint

Box Beam Tolerances:

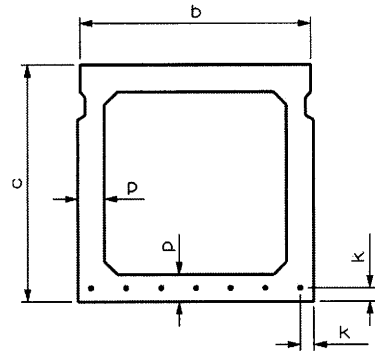

CROSS SECTION

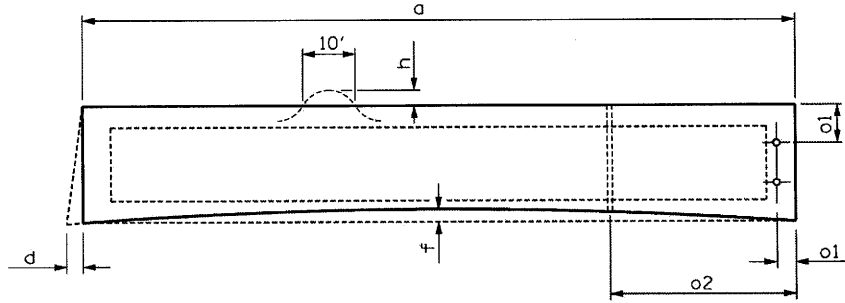

PLAN

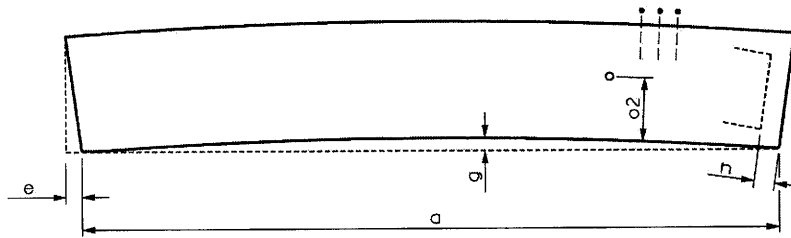

ELEVATION